

**IN THE UNITED STATES DISTRICT COURT
FOR THE EASTERN DISTRICT OF TEXAS
MARSHALL DIVISION**

INTELLECTUAL VENTURES I LLC and)	
INTELLECTUAL VENTURES II LLC,)	
)	
Plaintiffs,)	C.A. No. 2:21-cv-390
)	
v.)	
)	
HONDA MOTOR COMPANY, LTD.;)	JURY TRIAL DEMANDED
AMERICAN HONDA MOTOR COMPANY,)	
INC.; AMERICAN HONDA FINANCE)	
CORP.; HONDA OF AMERICA)	
MANUFACTURING, INC.; HONDA)	
MANUFACTURING OF ALABAMA, LLC;)	
and HONDA MANUFACTURING OF)	
INDIANA, LLC,)	
)	
Defendants.)	
)	
)	

COMPLAINT FOR PATENT INFRINGEMENT

Plaintiffs Intellectual Ventures I LLC and Intellectual Ventures II LLC (collectively, “Intellectual Ventures” or “Plaintiffs”), in their Complaint of patent infringement against Defendants Honda Motor Company, Ltd., American Honda Motor Company, Inc., American Honda Finance Corp., Honda of America Manufacturing, Inc., Honda Manufacturing of Alabama, LLC, and Honda Manufacturing of Indiana, LLC (collectively, “Honda” or “Defendants”), hereby allege as follows:

NATURE OF THE ACTION

1. This is a civil action for the infringement of United States Patent No. 6,832,283 (“the ’283 Patent”), United States Patent No. 9,602,608 (“the ’608 Patent”), United States Patent No. 7,891,004 (“the ’004 Patent”), United States Patent No. 9,291,475 (“the ’475 Patent”), United

States Patent No. 7,382,771 (“the ’771 Patent”), United States Patent No. 9,232,158 (“the ’158 Patent”), United States Patent No. 9,681,466 (“the ’466 Patent”), United States Patent No. 10,292,138 (“the ’138 Patent”), United States Patent No. 7,684,318 (“the ’318 Patent”), United States Patent No. 8,953,641 (“the ’641 Patent”), and United States Patent No. 8,811,356 (“the ’356 Patent”) (collectively, the “Patents-in-Suit”) under the Patent Laws of the United States, 35 U.S.C. § 1 *et seq.*

THE PARTIES

Intellectual Ventures

2. Plaintiff Intellectual Ventures I LLC (“Intellectual Ventures I”) is a Delaware limited liability company having its principal place of business located at 3150 139th Avenue SE, Bellevue, Washington 98005.

3. Plaintiff Intellectual Ventures II LLC (“Intellectual Ventures II”) is a Delaware limited liability company having its principal place of business located at 3150 139th Avenue SE, Bellevue, Washington 98005.

4. Intellectual Ventures I is the owner of all rights, title, and interest in and to the ’004 and ’318 Patents. Intellectual Ventures II is the owner of all rights, title, and interest in and to the ’283, ’475, ’771, ’128, ’608, ’466, ’138, ’641, and ’356 Patents.

Honda

5. Upon information and belief, Defendant Honda Motor Company, Ltd. (“HMC”) is a corporation organized and existing under the laws of Japan with a principal place of business at 2-1-1, Minami-Aoyama, Minato-Ku, Tokyo, 107-8556, Japan. On information and belief, HMC does business itself, or through its subsidiaries, affiliates, and agents, in the State of Texas and the Eastern District of Texas.

6. Upon information and belief, Defendant American Honda Motor Company, Inc. (“AHM”) is a corporation organized and existing under the laws of the State of California. On information and belief, AHM is the wholly owned subsidiary of HMC, which combines product sales, service, and coordinating functions of Honda in the United States, and is responsible for manufacturing, sales, offers for sale, marketing, importation, and distribution of automotive vehicles from Honda-managed brands (*e.g.*, Honda and Acura) in the United States. On information and belief, AHM has hundreds of employees based in and does business throughout the State of Texas including at, *e.g.*, the Honda Rider Education Center in Irving, the Parts Center in Irving, and the American Honda Finance Center in Irving.

7. Upon information and belief, Defendant American Honda Finance Corp. (“AHFC”) is a corporation organized and existing under the laws of the State of California. According to its most recent SEC Form 10-K filed March 31, 2021, AHFC is a wholly owned subsidiary of AHM, which in turn is a wholly-owned subsidiary of HMC, and is responsible for providing various forms of financing in the United States to purchasers and lessees of Honda and Acura products and authorized independent dealers of Honda and Acura products. (https://www.hondafinancialservices.com/investor-relations/IR_DCTM/quarterly_reports/AHFC-3.31.2021-10K%20As%20Filed.pdf at p. 2, 1). AHFC’s “primary focus, in collaboration with AHM [], is to provide support for the sale of Honda and Acura products and maintain customer and dealer satisfaction and loyalty. [AHFC’s] business is substantially dependent upon the sale of those Honda and Acura products in the United States [] and the percentage of those sales financed by [AHFC].” (*Id.* at p. 1). AHFC has “eight regional offices in the United States that are responsible for the acquisition, servicing, collection, and customer service activities related to our automobile retail loans and leases. These offices are

located in California, Texas, Massachusetts, Illinois, North Carolina, Delaware, and Georgia. In November 2020, [AHFC] finalized plans to consolidate [its] regional offices in the United States into three customer and dealer services centers located in California, Texas, and Georgia. (*Id.* at p. 3). “In addition to [these] servicing regions, [AHFC has] centralized certain operational functions in the United States relating to [its] automobile retail loans and leases at the National Service Center located in Texas, which contains [its] National Processing Center, Lease Maturity Center, Remarketing Center, and Recovery and Bankruptcy Center.” (*Id.* at p. 3).

8. Upon information and belief, Defendant Honda of America Manufacturing, Inc. (“HAM”) is a corporation organized and existing under the laws of Ohio. On information and belief, HAM is a wholly owned subsidiary of HMC, and is responsible for manufacturing automotive vehicles from Honda-managed brands (*e.g.*, Honda and Acura) for sale in the United States.

9. Upon information and belief, Defendant Honda Manufacturing of Alabama, LLC (“HMA”) is a corporation organized and existing under the laws of Alabama. On information and belief, HMA is a wholly owned subsidiary of HMC, and is responsible for manufacturing certain models of automotive vehicles from Honda (*e.g.*, Odyssey, Passport, Pilot, and Ridgeline) for sale in the United States.

10. Upon information and belief, Defendant Honda Manufacturing of Indiana, LLC (“HMI”) is a corporation organized and existing under the laws of Ohio. On information and belief, HMI is a wholly owned subsidiary of HMC, and is responsible for manufacturing certain models of automotive vehicles from Honda (*e.g.*, Civic, CR-V, and Insight) for sale in the United States.

11. On information and belief, Honda designs, manufactures, distributes, imports,

offers for sale, and/or sells in the State of Texas and the Eastern District of Texas automotive vehicles and components thereof that infringe the Patents-in-Suit, contributes to infringement by others, and/or induces others to commit acts of patent infringement in the State of Texas and the Eastern District of Texas. Honda has a regular and established places of business, at which it has committed acts of infringement and placed the accused products into the stream of commerce, throughout the State of Texas and the Eastern District of Texas, including at, *e.g.*, Tower Honda of Longview located at 600 East Loop 281, Longview, Texas 76505, Jack O Diamonds Honda located at 2600 W Southwest Loop 323, Tyler, Texas 75701, Orr Honda located at 4602 Gus Orr Drive, Texarkana, Texas 75503, Loving Honda located at 1701 South Medford Drive, Lufkin, Texas 75901, Mathews Honda of Paris located at 1505 NE Loop 286, Paris, Texas 75460, Twin City Honda located at 10545 Memorial Boulevard, Port Arthur, Texas 77640, Honda Cars of McKinney located at 601 South Central Expressway, McKinney, Texas 75070, and Honda of Frisco located at 1601 Dallas Parkway, Frisco, Texas 75034 (“Honda dealers”).

12. Upon information and belief, each of these authorized Honda dealers in this District are regular, continuous, and established physical places of business of Honda, being established, ratified, and/or controlled by Honda as authorized dealers, which are the exclusive places of business at which Honda offers for sale, sells, and provides authorized warranty, maintenance, and recall services for the Honda automotive vehicles and components that infringe the Patents-in-Suit.

13. Upon information and belief, Honda granted each of these authorized Honda dealers in this District the exclusive right to offer for sale, sell, and service the infringing Honda vehicles in this District, at these particular geographical locations, and has further conditioned these authorized dealers’ continued offering for sale, sale, and service of the infringing Honda

vehicles in this District on these authorized dealers' continued presence in this District, at these particular geographical locations, so that the infringing Honda automobiles and components are offered for sale, sold, and/or distributed in this District.

14. Upon information and belief, Honda ratifies and holds these authorized Honda dealers out as the regular and established places of business of Honda in this District by listing each of them in Honda's sales directories and on Honda's website(s), including, *e.g.*, as shown below:

Figure 1

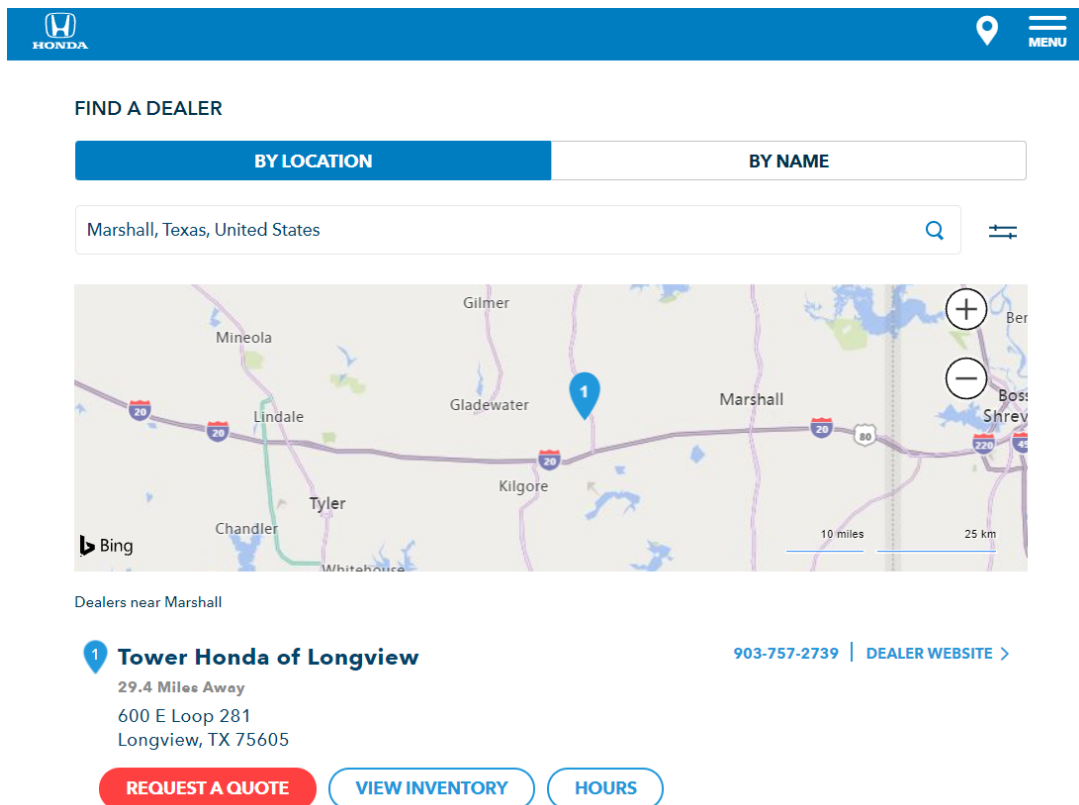

<https://automobiles.honda.com/tools/dealership-locator>

15. Upon information and belief, Honda further ratifies and holds these authorized Honda dealers out as the regular and established places of business of Honda in this District by offering for sale on Honda's website(s) the infringing automobiles and components at the physical,

geographical locations of these authorized Honda dealers, including, *e.g.*, as shown below:

Figure 2

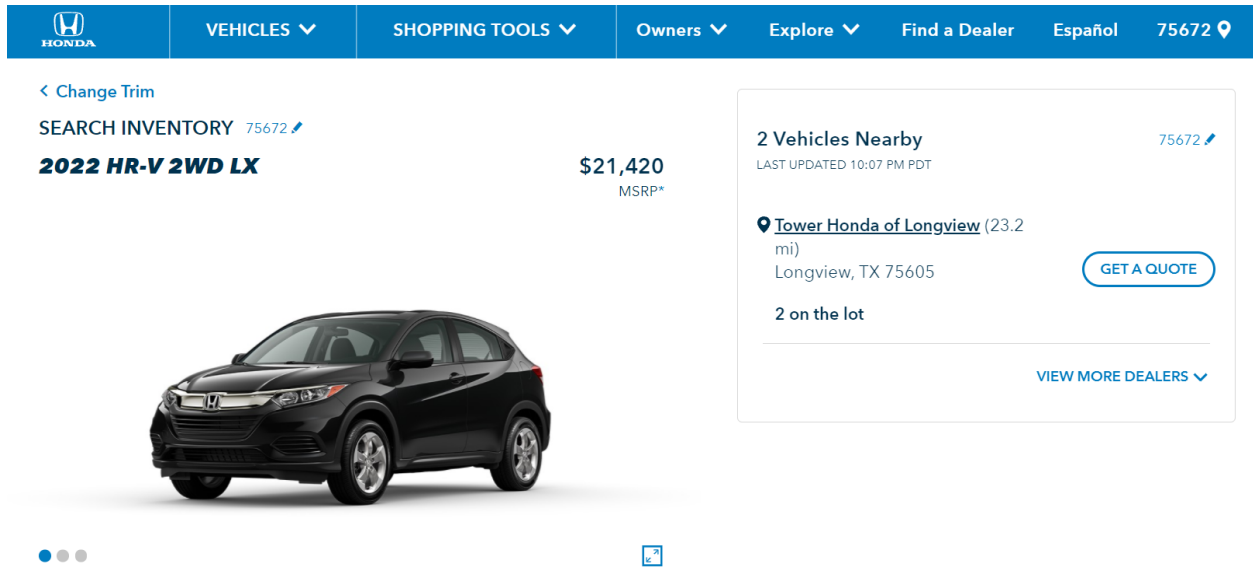

<https://automobiles.honda.com/tools/search-inventory?modelseries=hr-v&modelyear=2022&trimname=LX>

16. Upon information and belief, Honda further ratifies and holds these authorized Honda dealers out as the regular and established places of business of Honda in this District by requiring these authorized dealers to feature and use Honda names, branding, trademarks, and/or trade dress, in each of these authorized dealers' names, including, *e.g.*, Tower Honda of Longview, Jack O Diamonds Honda, Orr Honda, Loving Honda, Mathews Honda of Paris, Twin City Honda, Honda Cars of McKinney, and Honda of Frisco, as well as in the marketing and advertising materials that these authorized dealers use and make to offer for sale and sell the infringing automobiles and components in this District – including on each authorized dealer's website hosted, maintained, and shown to consumers in this District, *e.g.*, as shown below:

Figure 3

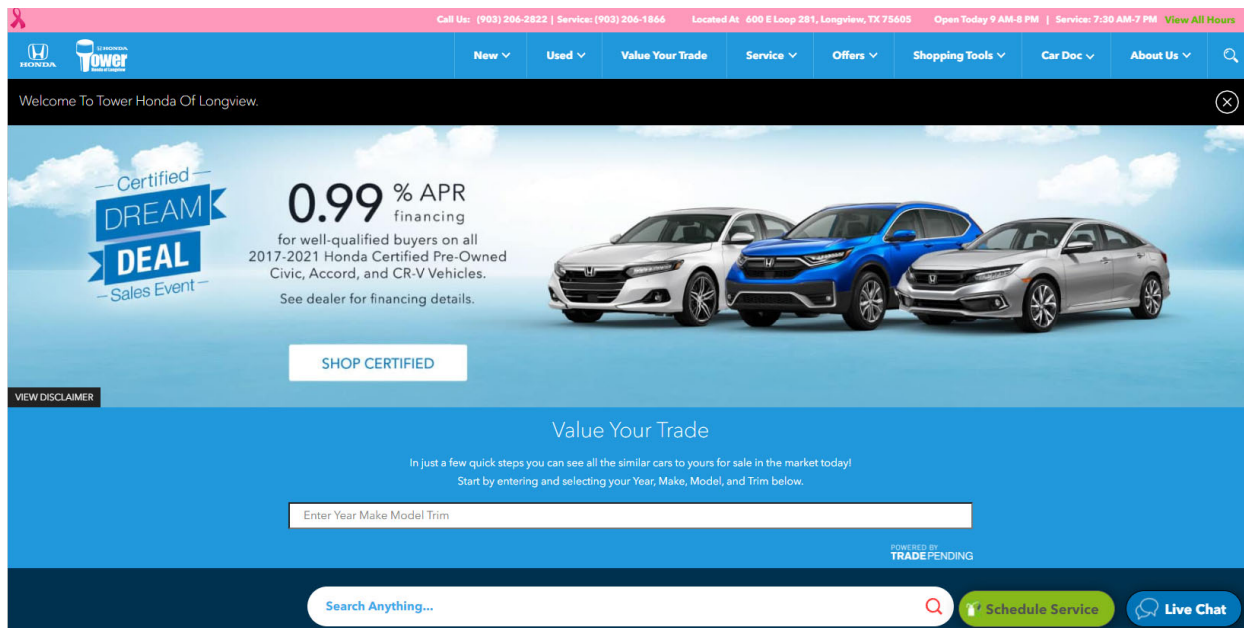

<https://www.towerhonda.com/>

17. Upon information and belief, Honda further ratifies and holds these authorized Honda dealers out as the regular and established places of business of Honda in this District by controlling in whole or in part the name, geographical location, design, layout, marketing, and branding of these places to test drive and purchase the infringing Honda automobiles and components, including, *e.g.*, as shown below:

Figure 4



<https://www.towerhonda.com/>

18. Upon information and belief, Honda further ratifies and holds these authorized Honda dealers out as the regular and established places of business of Honda in this District by requiring these businesses to store, display, and/or distribute marketing materials, informational brochures, product specifications, service information, warranty information, lease information, financing information, and various other literature, as well as Honda authorized service, parts, and accessories, for the infringing automobiles and components, including, *e.g.*, as shown below:

Figure 5

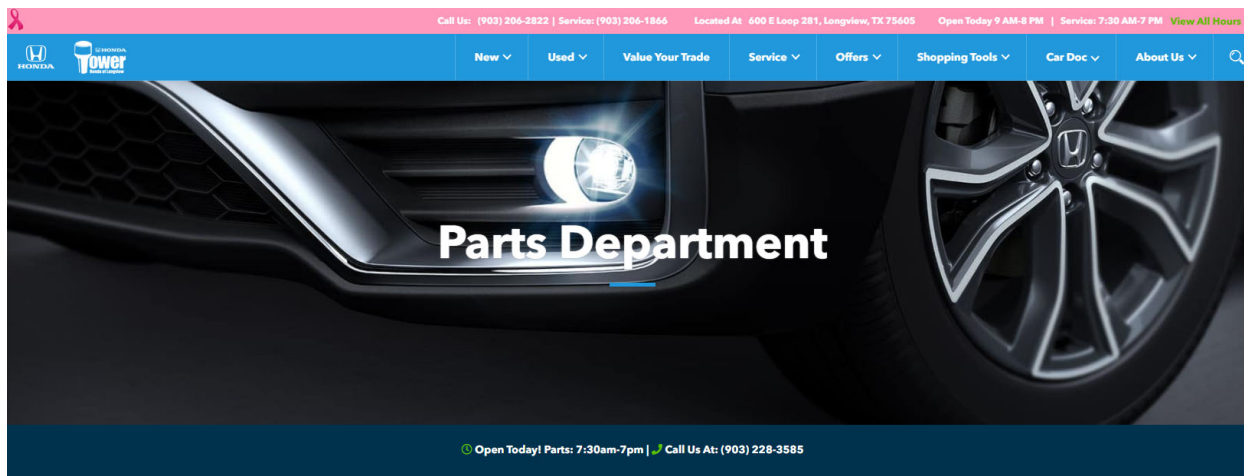

Genuine Honda Parts from Tower Honda of Longview

As your automotive dealership, we're dedicated to delivering high-quality service to you at every step of the car ownership process. That means delivering genuine OEM parts to our customers whether they're planning a DIY home auto project, need repairs at our dealership, or want to improve their car with new accessories.

Phone Numbers: Main: [Schedule Service](#) [Live Chat](#)

<https://www.towerhonda.com/parts/>

Figure 6

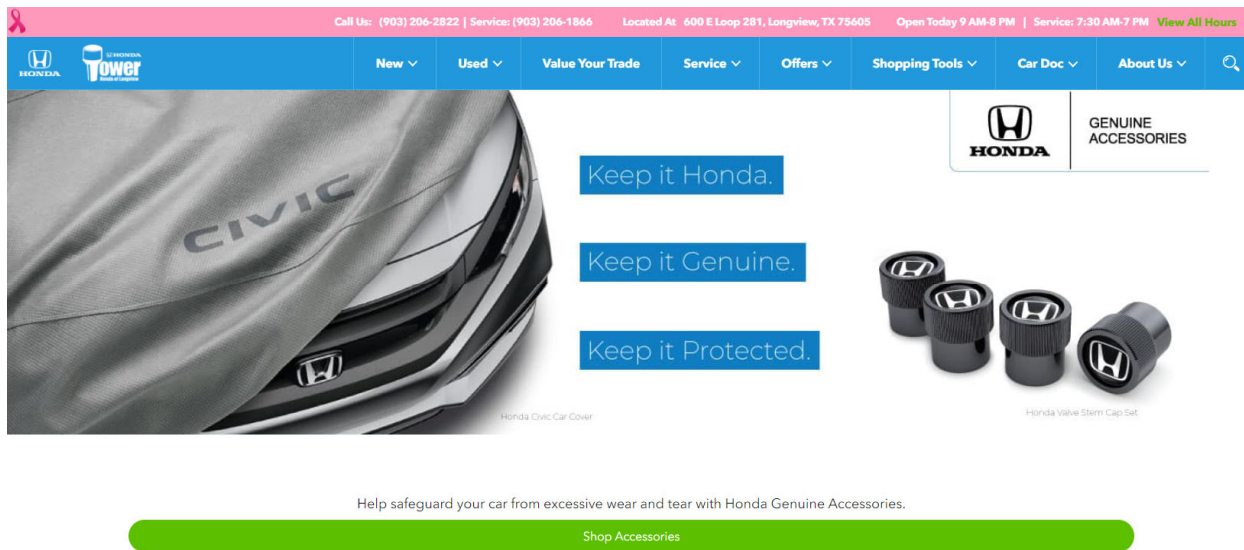

<https://www.towerhonda.com/honda-genuine-accessories/>

19. Upon information and belief, Honda further ratifies and holds these authorized Honda dealers out as the regular and established places of business of Honda in this District by

establishing, authorizing, and requiring these places of business to offer to consumers in this District, at the time of sale and/or distribution of the infringing automobiles and components, Honda financial services and products, Honda warranties, Honda service from Honda certified and/or trained technicians, Honda parts, and Honda accessories.

20. Upon information and belief, Honda further ratifies and holds these authorized Honda dealers out as the regular and established places of business of Honda in this District by recruiting, hiring, training, offering compensation and benefits to, controlling, and/or labeling as authorized or certified Honda employees and agents some or all of the employees or agents employed in this District by these authorized dealers, including for example, Honda certified brand advisors, Honda certified technicians, and Honda certified service advisors, including, *e.g.*, as shown below:

Figure 7

Honda Factory-Trained Technicians

All Honda Service Professionals are required to pass a series of in-dealership training programs, training classes, and more.

Through it all, Honda Service Professionals are accomplished and dedicated. These technicians, advisors, warranty administrators, cashiers, receptionists, dispatchers, and service managers are committed to doing what they do.

Why service your vehicle at Tower Honda of Longview?

- Our technicians work on all Honda vehicles. That means all models, years, and mileages. They are the experts. Only dealership staff can get current training directly from Honda.
- Dealerships get up-to-date technical resources for the model and year of your vehicle.
- Dealers use Genuine Honda Parts. You know they will fit right, function properly and last a long time.
- Dealers maintain a large inventory and can get parts overnight.
- They work with you to properly care for your vehicle. At your request, they'll take a drive with you, at the time of drop-off and when you pick it up, to ensure that you're completely satisfied.
- A quality-control check is conducted on the dealership's warranty work, so you can be assured that your vehicle will be fixed right the first time.
- A guarantee on maintenance and repair work. American Honda backs all Genuine Honda replacement parts with a limited warranty of 12 months or 12,000 miles, whichever comes first.

<https://www.oceanhondasantacruz.com/tips-advice/honda-factory-trained-technicians/>

21. Upon information and belief, Honda further ratifies and holds these authorized

Honda dealers out as the regular and established places of business of Honda by providing these dealers sales promotions, providing these dealers financing for dealership improvements directed by Honda, and sharing customer data with these dealers to provide customized Honda services.

22. Upon information and belief, Honda further ratifies and holds these authorized Honda dealers out as the regular and established places of business of Honda in this District by establishing, authorizing, and requiring consumers in this District to visit and use these authorized dealers in order to obtain authorized Honda service, obtain scheduled maintenance under any Honda service plan, make repairs pursuant to any Honda warranty, or obtain any recall work for all new Honda automobiles and components, including the infringing automobiles and components, including, *e.g.*, as shown below:

Figure 8

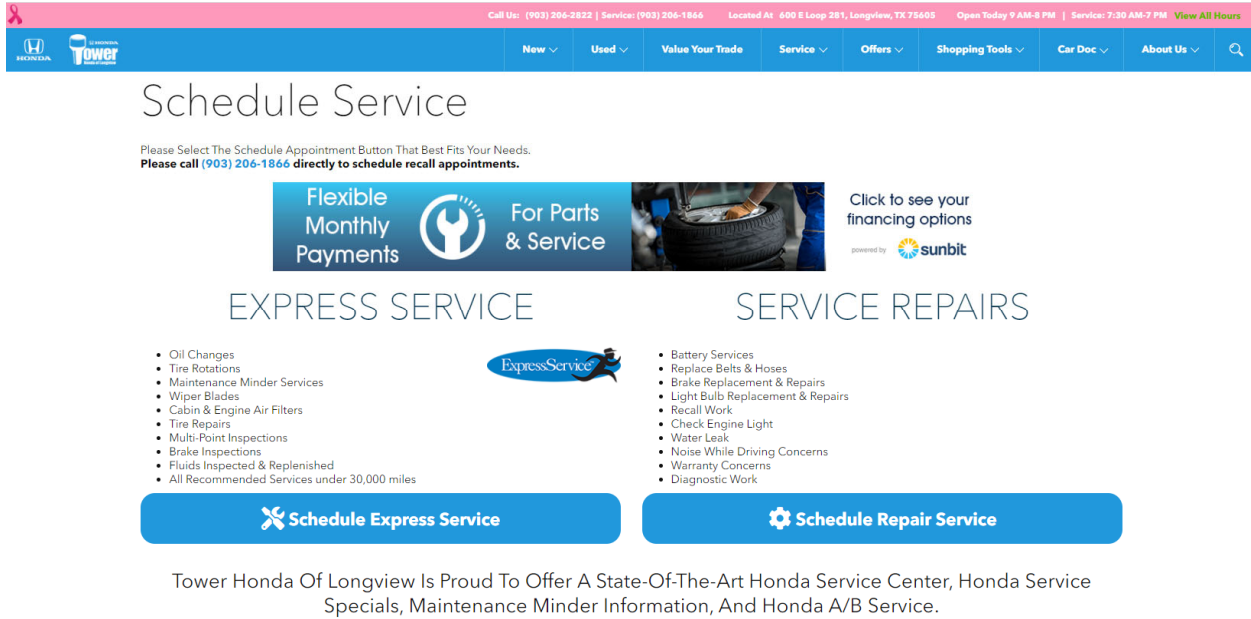

Schedule Service

Please Select The Schedule Appointment Button That Best Fits Your Needs.
Please call (903) 206-1866 directly to schedule recall appointments.

Flexible Monthly Payments For Parts & Service

Click to see your financing options
powered by sunbit

EXPRESS SERVICE

- Oil Changes
- Tire Rotations
- Maintenance Minder Services
- Wiper Blades
- Cabin & Engine Air Filters
- Tire Repairs
- Multi-Point Inspections
- Brake Inspections
- Fluids Inspected & Replenished
- All Recommended Services under 30,000 miles

Schedule Express Service

SERVICE REPAIRS

- Battery Services
- Replace Belts & Hoses
- Brake Replacement & Repairs
- Light Bulb Replacement & Repairs
- Recall Work
- Check Engine Light
- Water Leak
- Noise While Driving Concerns
- Warranty Concerns
- Diagnostic Work

Schedule Repair Service

Tower Honda Of Longview Is Proud To Offer A State-Of-The-Art Honda Service Center, Honda Service Specials, Maintenance Minder Information, And Honda A/B Service.

<https://www.towerhonda.com/service/schedule-service/>

Figure 9

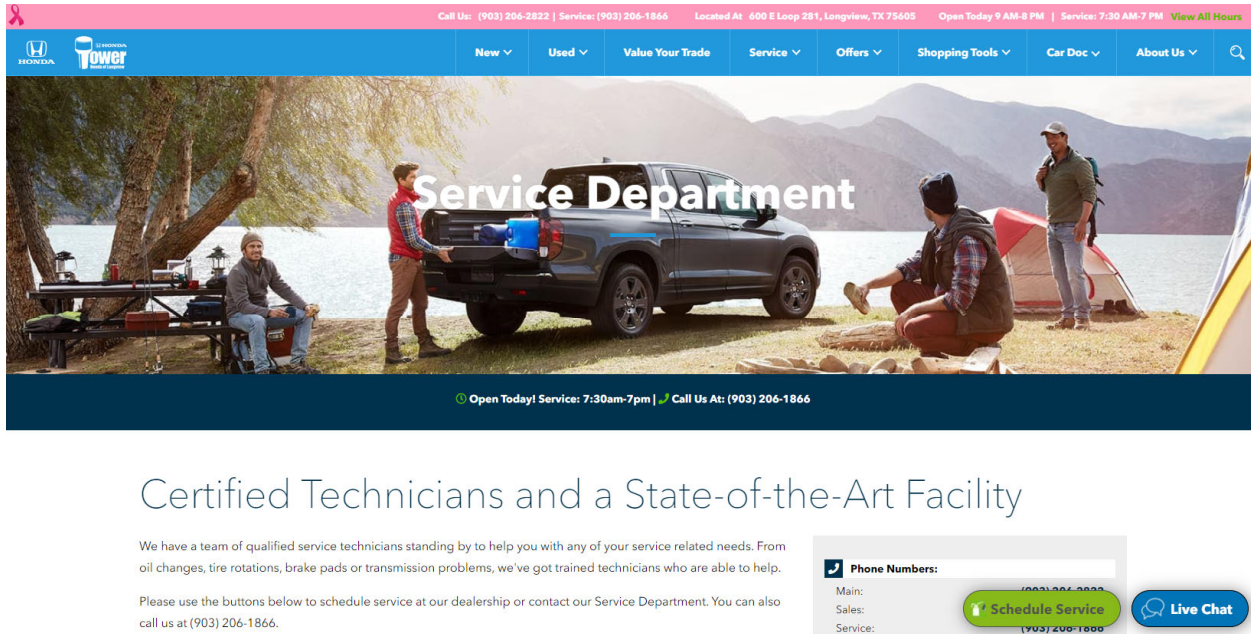

Service Department

Certified Technicians and a State-of-the-Art Facility

We have a team of qualified service technicians standing by to help you with any of your service related needs. From oil changes, tire rotations, brake pads or transmission problems, we've got trained technicians who are able to help.

Please use the buttons below to schedule service at our dealership or contact our Service Department. You can also call us at (903) 206-1866.

Phone Numbers: (903) 206-1866

Main: (903) 206-1866
Sales: (903) 206-1866
Service: (903) 206-1866

Schedule Service **Live Chat**

Open Today! Service: 7:30am-7pm | Call Us At: (903) 206-1866

<https://www.towerhonda.com/service/>

23. Upon information and belief, Honda has established and ratified and holds these authorized Honda dealers out as the regular and established places of business of Honda by

directing and controlling these authorized dealers' actions, sales, and services in the foregoing manner, and has consented to these authorized dealers acting on Honda's behalf and being the exclusive places of business whereby the infringing automobiles and components are distributed, offered for sale, sold, and serviced in order to place these infringing articles into the stream of commerce in this District, and these authorized dealers have consented to act on Honda's behalf pursuant to the foregoing terms of control and direction in order to be able to provide these Honda automobiles, components, and services to consumers in this District.

JURISDICTION AND VENUE

24. This is an action for patent infringement arising under the patent laws of the United States. This Court has subject matter jurisdiction pursuant to 28 U.S.C. §§ 1331 and 1338(a).

25. This Court has personal jurisdiction over Honda because Honda conducts business in and has committed acts of patent infringement, contributed to infringement by others, and/or induced others to commit acts of patent infringement in this District, the State of Texas, and elsewhere in the United States and has established minimum contacts with this forum state such that the exercise of jurisdiction over Honda would not offend the traditional notions of fair play and substantial justice. Upon information and belief, Honda transacts substantial business with entities and individuals in the State of Texas and the Eastern District of Texas, by among other things, importing, offering to sell, distributing, and selling products that infringe the Patents-in-Suit, including the infringing automotive vehicles and components thereof that Honda purposefully directs into the State of Texas and this District as alleged herein, as well as by providing service and support to its customers in this District. Honda places the accused automotive vehicles and components thereof into the stream of commerce via authorized and established distribution channels with the knowledge and expectation that they will be sold in the

State of Texas, including this District, and do not otherwise permit the sale of the accused automotive vehicles and components thereof in the State of Texas, or in this District, outside of these established, authorized, and ratified distribution channels and dealer networks.

26. Venue is proper in this District pursuant to 28 U.S.C. §§ 1391(b)-(c) and 1400(b) because Honda has committed acts of infringement in this District and maintains numerous regular and established places of business in this District.

27. Honda is subject to this Court's general and specific jurisdiction pursuant to due process and/or the Texas Long Arm Statute due at least to Honda's substantial business in the State of Texas and this District, including through its past infringing activities, because Honda regularly does and solicits business herein, and/or because Honda has engaged in persistent conduct and/or has derived substantial revenues from goods and services provided to customers in the State of Texas and this District.

FACTUAL BACKGROUND

28. Intellectual Ventures Management, LLC ("Intellectual Ventures Management") was founded in 2000. Since then, Intellectual Ventures Management has been involved in the business of inventing. Intellectual Ventures Management creates inventions and files patent applications for those inventions; collaborates with others to develop and patent inventions; and acquires and licenses patents from individual inventors, universities, corporations, and other institutions. A significant aspect of Intellectual Ventures Management's business is managing the plaintiffs in this case, Intellectual Ventures I and Intellectual Ventures II.

29. To create its own inventions, Intellectual Ventures Management has a staff of scientists and engineers who develop ideas in a broad range of fields, including agriculture, computer hardware, life sciences, medical devices, semiconductors, and software. Intellectual

Ventures Management has invested millions of dollars developing such ideas and has filed hundreds of patent applications on its inventions. Intellectual Ventures Management has also invested in laboratory facilities to assist with the development and testing of new ideas.

30. One of the founders of Intellectual Ventures Management is Nathan Myhrvold, who worked at Microsoft from 1986 until 2000 in a variety of executive positions, culminating in his appointment as the company's first Chief Technology Officer ("CTO") in 1996. While at Microsoft, Dr. Myhrvold founded Microsoft Research in 1991 and was one of the world's foremost software experts. Between 1986 and 2000, Microsoft became the world's largest technology company.

31. Under Dr. Myhrvold's leadership, Intellectual Ventures acquired more than 70,000 patents covering many important inventions of the Internet era. Many of these inventions coincided with Dr. Myhrvold's successful tenure at Microsoft.

32. One of the most significant accomplishments of the Internet era is the emergence of wireless technologies for vehicles. Wireless connectivity systems in vehicles enable communication channels within vehicles as well as with other external networks. Intellectual Ventures' Patents-In-Suit provide improvements to wireless communications used in vehicles.

33. Honda incorporates several types of wireless communication system solutions and services in their vehicles that Honda sells and leases to its customers. Honda's product offerings include but are not limited to: Satellite-linked Navigation System™; infotainment systems; Wi-Fi connect with mobile hotspot technology; Snapdragon Automotive 4G Platform; HondaLink®; Telematics; and 4G LTE connectivity. These product offerings are included in various of Honda's car models, including but not limited to, Honda CVR, Honda Odyssey, Honda Accord, Honda Pilot, Honda Insight, and Honda Passport. Honda markets and sells these wireless communication system

solutions and services in several Honda models throughout the world, including in the United States and Texas.

THE PATENTS-IN-SUIT

U.S. Patent No. 6,832,283

34. On December 14, 2004, the PTO issued the '283 Patent, titled "METHOD FOR ADDRESSING NETWORK COMPONENTS." The '283 Patent is valid and enforceable. A copy of the '283 Patent is attached as Exhibit 1.

35. Intellectual Ventures II is the owner of all rights, title, and interest in and to the '283 Patent, and holds all substantial rights therein, including the right to grant licenses, to exclude others, and to enforce and recover past damages for infringement of the '283 Patent.

36. The '283 Patent generally relates to systems and methods for addressing components of a network, especially in the case of data bus systems in transport means, in which each component is assigned a first address for the mutual communication within the network and the first addresses are stored in a central register. The network addressing systems and methods covered by the '283 Patent include addressing components of a first network, especially in the case of data bus systems in transport vehicles, in which each component is assigned a first address for the mutual communication within the network and the first addresses are stored in a central register, in which at least one particular component of the first network communicates with another network, this component, when dialing into the second network, is assigned a second address by the latter and, within the first network, addressing takes place on the basis of function-specific address components, identical function blocks of the components being addressed via identical function-specific address components.

U.S. Patent No. 9,602,608

37. On March 21, 2017, the PTO issued the '608 Patent, titled "SYSTEM AND METHOD FOR NOTIFYING A USER OF PEOPLE, PLACES OR THINGS HAVING ATTRIBUTES MATCHING A USER'S STATED PREFERENCE." The '608 Patent is valid and enforceable. A copy of the '608 Patent is attached as Exhibit 2.

38. Intellectual Ventures II is the owner of all rights, title, and interest in and to the '608 Patent, and holds all substantial rights therein, including the right to grant licenses, to exclude others, and to enforce and recover past damages for infringement of the '608 Patent.

39. The '608 Patent generally relates to communications systems and methods for providing localized resource information to mobile customers based on their explicit preferences that match profiles of media content about people, places and things. The communication systems, apparatus, and methods covered by the '608 Patent include location-based and preference-based systems and methods for matching media content about persons, places and things with the expressed preferences of mobile users to notify users about and provide users with access to media content about persons, places and things that match the user's expressed preferences. The systems covered by the '608 Patent provide information such as stories or articles that match the user's interests and relate to their location.

U.S. Patent No. 7,891,004

40. On February 15, 2011, the PTO issued the '004 Patent, titled "METHOD FOR VEHICLE INTERNETWORKS." The '004 Patent is valid and enforceable. A copy of the '004 Patent is attached as Exhibit 3.

41. Intellectual Ventures I is the owner of all rights, title, and interest in and to the '004 Patent, and holds all substantial rights therein, including the right to grant licenses, to

exclude others, and to enforce and recover past damages for infringement of the '004 Patent.

42. The '004 Patent generally relates to intelligent networks that include connections to the physical world. For example, the invention relates to providing distributed network and Internet access to processors, controls, and devices in vehicles. The networks covered by the '004 Patent provide for communications among diverse electronic devices within a vehicle, and for communications among these devices and networks external to the vehicle. The networks covered by the '004 Patent comprise specific devices, software, and protocols, and provide for security for essential vehicle functions and data communications, ease of integration of new devices and services to the vehicle internetwork, and ease of addition of services linking the vehicle to external networks such as the Internet.

U.S. Patent No. 9,291,475

43. On March 22, 2016, the PTO issued the '475 Patent, titled "DEVICE, SYSTEM AND METHOD FOR CONTROLLING SPEED OF A VEHICLE USING A POSITIONAL INFORMATION DEVICE." The '475 Patent is valid and enforceable. A copy of the '475 Patent is attached as Exhibit 4.

44. Intellectual Ventures II is the owner of all rights, title, and interest in and to the '475 Patent, and holds all substantial rights therein, including the right to grant licenses, to exclude others, and to enforce and recover past damages for infringement of the '475 Patent.

45. The '475 Patent generally relates to navigational or positional information systems, and more particularly, to devices, systems, and methods for controlling the speed of a vehicle using a positional information device, *e.g.*, a global positioning system (GPS) device. For example, the systems include a locational information module for determining location information and speed; a storage module for storing at least one geographic map including at least

one route and a speed limit for at least one route; a processing module configured to receive the location information, retrieve at least one geographic map based on the location information, determine the speed limit based on the location information, and compare the speed of the device to the determined speed limit; and a display module for alerting a user if the speed of the device exceeds the determined speed limit.

U.S. Patent No. 7,382,771

46. On June 3, 2008, the PTO issued the '771 Patent, titled "MOBILE WIRELESS HOTSPOT SYSTEM." The '771 Patent is valid and enforceable. A copy of the '771 Patent is attached as Exhibit 5.

47. Intellectual Ventures II is the owner of all rights, title, and interest in and to the '771 Patent, and holds all substantial rights therein, including the right to grant licenses, to exclude others, and to enforce and recover past damages for infringement of the '771 Patent.

48. The '771 Patent generally relates to wireless Internet access points, and in particular, for example, for providing an improved mobile wireless access point for use with high-speed wireless devices. For example, a system allows client devices configured for short-range, high-speed wireless Internet access to use said system to access the Internet while in a mobile environment, such as a passenger vehicle.

U.S. Patent No. 9,232,158

49. On January 5, 2016, the PTO issued the '158 Patent, titled "LARGE DYNAMIC RANGE CAMERAS." The '158 Patent is valid and enforceable. A copy of the '158 Patent is attached as Exhibit 6.

50. Intellectual Ventures II is the owner of all rights, title, and interest in and to the '158 Patent, and holds all substantial rights therein, including the right to grant licenses, to

exclude others, and to enforce and recover past damages for infringement of the '158 Patent.

51. The '158 Patent generally relates to optical devices and more particularly to expanding the dynamic exposure range in digital cameras.

U.S. Patent No. 9,681,466

52. On June 13, 2017, the PTO issued the '466 Patent, titled "SCHEDULING TRANSMISSIONS ON CHANNELS IN A WIRELESS NETWORK." The '466 Patent is valid and enforceable. A copy of the '466 Patent is attached as Exhibit 7.

53. Intellectual Ventures II is the owner of all rights, title, and interest in and to the '466 Patent, and holds all substantial rights therein, including the right to grant licenses, to exclude others, and to enforce and recover past damages for infringement of the '466 Patent.

54. The '466 Patent generally relates to mechanisms to support Internet Protocol data flows within a wireless communication system, applicable to, but not limited to, gateway queuing algorithms in packet data transmissions, for example, for use in the universal mobile telecommunication system.

U.S. Patent No. 10,292,138

55. On May 14, 2019, the PTO issued the '138 Patent, titled "DETERMINING BUFFER OCCUPANCY AND SELECTING DATA FOR TRANSMISSION ON A RADIO BEARER." The '138 Patent is valid and enforceable. A copy of the '138 Patent is attached as Exhibit 8.

56. Intellectual Ventures II is the owner of all rights, title, and interest in and to the '138 Patent, and holds all substantial rights therein, including the right to grant licenses, to exclude others, and to enforce and recover past damages for infringement of the '138 Patent.

57. The '138 Patent generally relates to mechanisms to support Internet Protocol data

flows within a wireless communication system, applicable to, but not limited to, gateway queuing algorithms in packet data transmissions, for example, for use in mobile telecommunications. The products and methods covered by the '138 Patent relate to user equipment (UE) that may determine and transmit to a network buffer occupancy associated with one or more radio bearers, and may select data for transmission from radio bearers using a received single allocation of uplink resources.

U.S. Patent No. 7,684,318

58. On March 23, 2010, the PTO issued the '318 Patent, titled "SHARED-COMMUNICATIONS CHANNEL UTILIZATION FOR APPLICATIONS HAVING DIFFERENT CLASS OF SERVICE REQUIREMENTS." The '318 Patent is valid and enforceable. A copy of the '318 Patent is attached as Exhibit 9.

59. Intellectual Ventures I is the owner of all rights, title, and interest in and to the '318 Patent, and holds all substantial rights therein, including the right to grant licenses, to exclude others, and to enforce and recover past damages for infringement of the '318 Patent.

60. The '318 Patent generally relates to telecommunications in general, and, more particularly, to a technique for enabling the stations in a local area network to intelligently use their shared-communications channel. For example, at least one of the inventions set forth in the '318 Patent enables latency-tolerant and latency-intolerant applications to intelligently share a shared-communications channel in a manner that seeks to satisfy the needs of all of the applications. An illustrative embodiment enables each application to be associated with a different class of service, wherein each class of service is associated with one or more quality-of-service parameters (*e.g.*, minimum throughput, maximum latency, etc.).

U.S. Patent No. 8,953,641

61. On February 10, 2015, the PTO issued the '641 Patent, titled "METHODS AND APPARATUS FOR MULTI-CARRIER COMMUNICATIONS WITH VARIABLE CHANNEL BANDWIDTH." The '641 Patent is valid and enforceable. A copy of the '641 Patent is attached as Exhibit 10.

62. Intellectual Ventures II is the owner of all rights, title, *and* interest in and to the '641 Patent, and holds all substantial rights therein, including the right to grant licenses, to exclude others, and to enforce and recover past damages for infringement of the '641 Patent.

63. The '641 Patent generally relates to methods and apparatus for multi-carrier communication with variable channel bandwidth.

U.S. Patent No. 8,811,356

64. On August 19, 2014, the PTO issued the '356 Patent, titled "COMMUNICATIONS IN A WIRELESS NETWORK." The '356 Patent is valid and enforceable. A copy of the '356 Patent is attached as Exhibit 11.

65. Intellectual Ventures II is the owner of all rights, title, and interest in and to the '356 Patent, and holds all substantial rights therein, including the right to grant licenses, to exclude others, and to enforce and recover past damages for infringement of the '356 Patent.

66. The '356 Patent generally relates to equipment and methods used in communication systems in a wireless network. The equipment and methods covered by the '356 Patent generally relate to receiving resource allocation information associated with an uplink physical control channel.

COUNT I

(Honda's Infringement of U.S. Patent No. 6,832,283)

67. Paragraphs 1-66 are incorporated by reference as if fully set forth herein.

68. Honda has directly infringed, and continues to directly infringe, literally and/or by the doctrine of equivalents, individually and/or jointly, the '283 Patent, by making, using, performing, testing, selling, offering for sale and/or importing into the United States vehicles that embody products and/or services that infringe the '283 Patent including, but not limited to, the Honda Odyssey, Honda Passport, and Honda Pilot (collectively, "Honda Count I Automobiles").

69. As an exemplary claim, Claim 1 of the '283 Patent, is reproduced below:

1. Method for addressing components of a first network in a data bus system in a transport vehicle, in which each component is assigned a first address for mutual communication within the network and the first addresses are stored in a central register, wherein at least one particular component of the first network communicates with a second network, said one component, when dialling [sic] into the second network, is assigned a second address by the second network, and wherein, within the first network, addressing takes place on the basis of function-specific address components, identical function blocks of the components being addressed via identical function-specific address components.

70. For example, upon information and belief, Honda and the Honda Count I Automobiles perform or can perform each and every limitation of claim 1 of the '283 Patent. Upon information and belief, the Honda Count I Automobiles include a Honda Infotainment system and HondaLink® that use the MOST Automotive Multimedia Network ("MOST").

71. Upon information and belief, the Honda Count I Automobiles include a first network of components in data bus systems using, for example, MOST networks, as the below example shows:

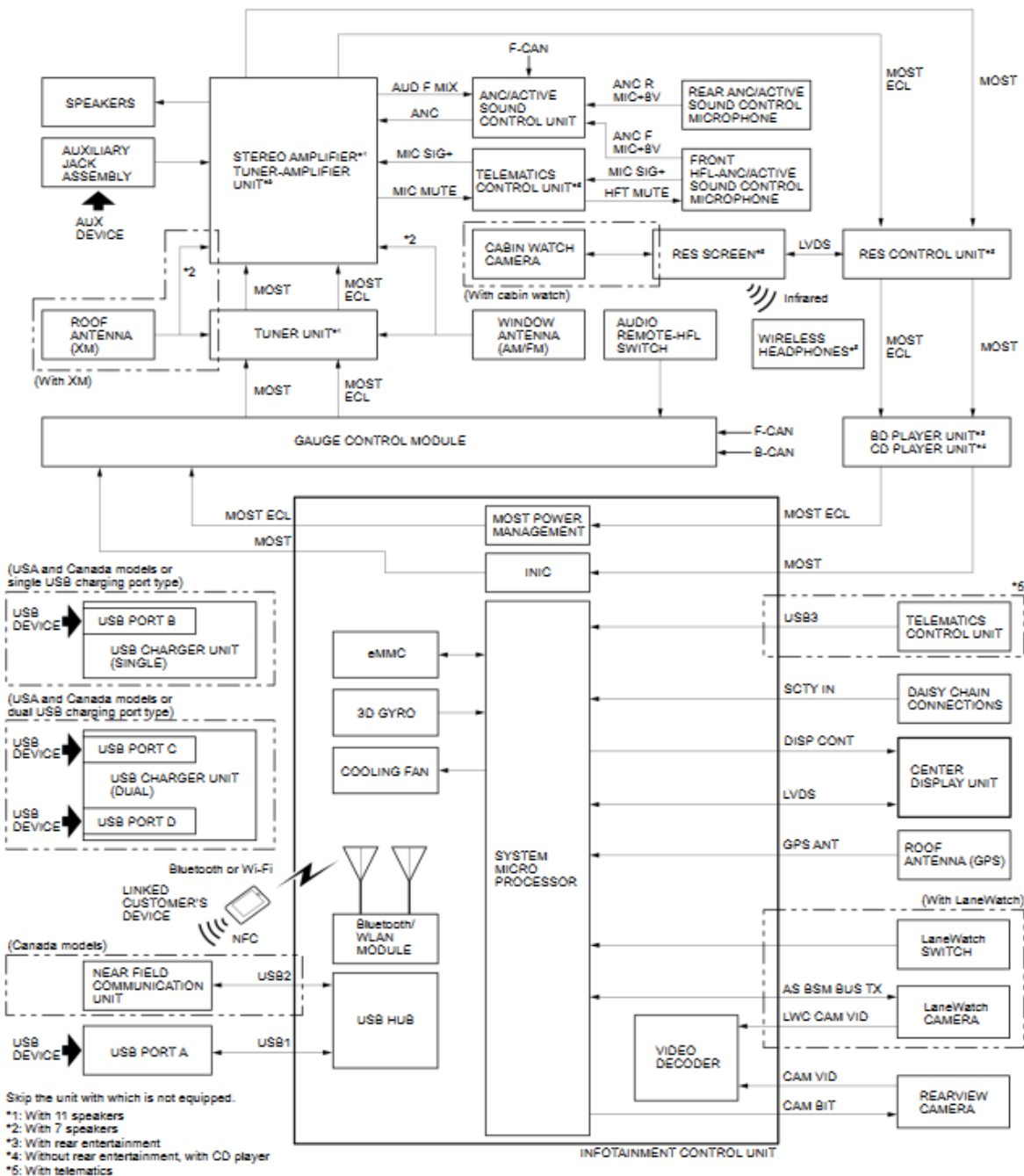

See Exhibit 22, Audio and Visual System Description – System Diagram at p. 2.

72. Upon information and belief, the Honda Count I Automobiles using, for example, MOST, address the components in the first network, in which each component is assigned a first address for mutual communication within the network, addressing takes place on the basis of

function-specific address components, with identical function blocks of the components being addressed via identical function-specific address components.

2.1.2.6 Addressing MOST Functions

In a MOST network, the devices are connected in a ring structure. To address these devices, different types of addresses can be used. The MOST Network Interface Controller provides six different types of addresses, which are introduced below.

2.1.2 Device Model

The following sections describe the logical model of a MOST device. A MOST device is a physical unit that can be connected to a MOST network via a MOST Network Interface Controller.

On the application level, a MOST device contains multiple components that are called function blocks (FBlocks), for example, tuner, amplifier, or CD player. It is possible that there are multiple FBlocks in a single MOST device, such as a tuner and an amplifier combined in one case and connected to the MOST network via a common MOST Network Interface Controller.

Exhibit 12, MOST Specification Rev. 3.0 E2 (07/2010) at pp. 39, 34

73. Upon information and belief, the Honda Count I Automobiles include a central registry that stores the first addresses of the components.



3.1.3.3.2 Central Registry

The NetworkMaster generates the Central Registry during the initialization of the network and it continues to administrate it until Network Shutdown (section 3.1.2.3.2). The Central Registry is an image of the physical and logical system configuration. It contains the logical node address and the respective FBlocks of each device:

DeviceID	The DeviceID stands for a physical device or a group of devices in the network. The DeviceID (RxTxAdr) can represent a node position address (RxTxPos), a logical address (RxTxLog), or a group address.
----------	--

RxTxLog	RxTxPos	FBlockID	InstID
0x0100	0	AudioDiskPlayer	1
		NetworkMaster	10
		ConnectionMaster	1
0x0101	1	AudioDiskPlayer	2
0x0102	2	AM/FMTuner	1
		AudioTapeRecorder	1
0x0103	3	AudioAmplifier	2
Etc.			
MaxNode	MaxNode	HumanMachineInterface	1

Table 3-10: Example of a Central Registry

Exhibit 12, MOST Specification Rev. 3.0 E2 (07/2010) at p. 140

74. Upon information and belief, the Honda Count I Automobiles' Infotainment

System, HondaLink, or other systems or components therein communicate with other networks, such as other Honda’s internal networks and/or cellular networks, as for example, shown below.

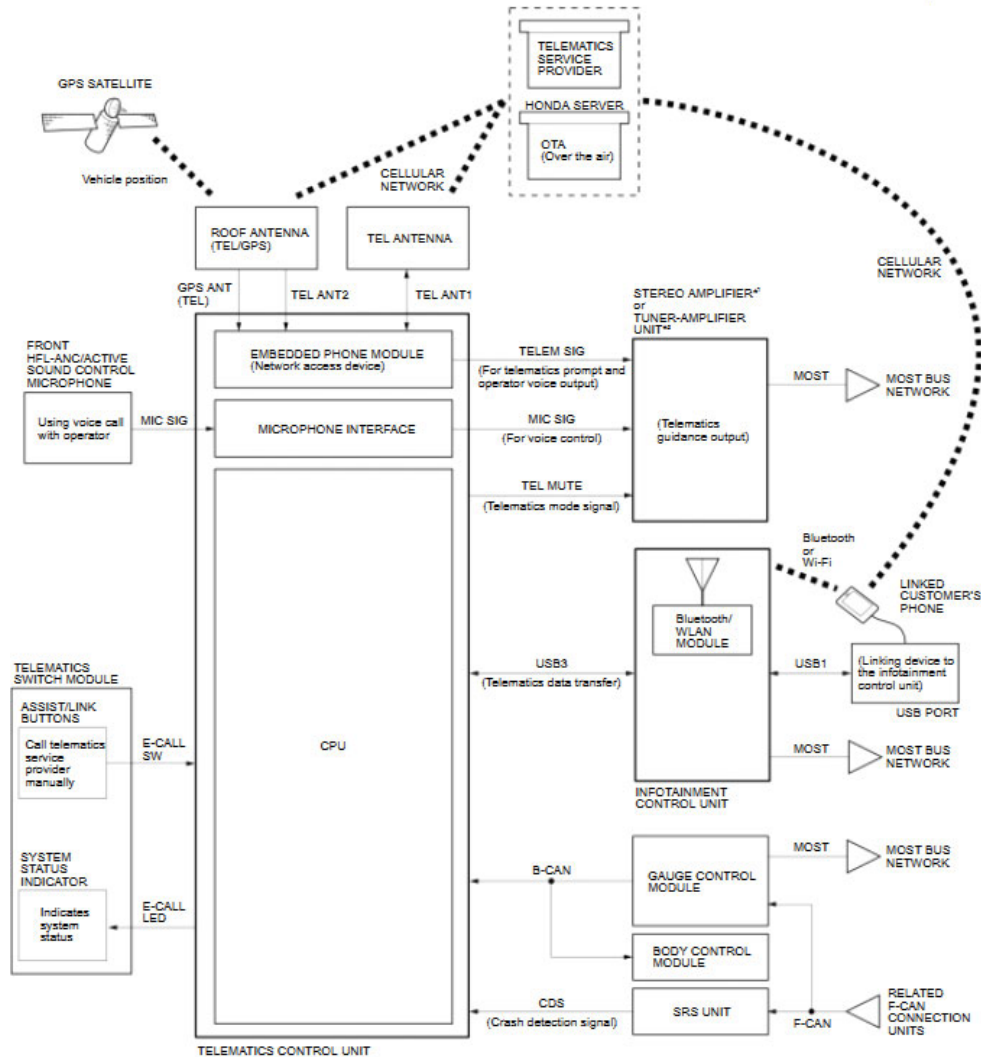

See Exhibit 23, Telematics System Description – System Diagram at p. 2.

75. Upon information and belief, the Honda Count I Automobiles’ Infotainment System, HondaLink, or other systems or components therein are assigned a second address by the other (second) network.

76. Accordingly, Honda and/or the Honda Automobiles operating, for example, the Infotainment, HondaLink®, and Telematics systems within and external to the Honda Count I Automobiles for, among other things, diagnostics directly infringe the methods covered by one or

more claims of the '283 Patent.

77. Additionally, Honda has been, and currently is, actively inducing infringement of the '283 Patent under 35 U.S.C. § 271(b) and contributorily infringing the '283 Patent under 35 U.S.C. § 271(c) either literally and/or by the doctrine of equivalents.

78. Honda knew of the '283 Patent, or should have known of the '283 Patent, but was willfully blind to its existence. Honda has had actual knowledge of the '283 Patent since not later than receipt of a letter dated October 18, 2021 and received on the same date. By the time of trial, Honda will have known and intended (since receiving such notice) that its continued actions would infringe and actively induce and contribute to the infringement of one or more claims of the '283 Patent.

79. Honda has committed, and continues to commit, affirmative acts that cause infringement of one or more claims of the '283 Patent with knowledge of the '283 Patent and knowledge or willful blindness that the induced acts constitute infringement of one or more claims of the '283 Patent. As an illustrative example only, Honda induces such acts of infringement by its affirmative action of providing and promoting the described hardware and/or software components and features in the Honda Count I Automobiles that when used in their normal and customary way as intended and designed by Honda, infringe one or more claims of the '283 Patent. As an illustrative example only, Honda induces such acts of infringement by providing its customers instructions on how to use its products and services in a manner or configuration that infringes one or more claims of the '283 Patent.

80. Honda has also committed, and continues to commit, contributory infringement by, *inter alia*, knowingly selling products and/or methods or services that when used cause the direct infringement of one or more claims of the '283 Patent by a third party, and which have no

substantial non-infringing uses, or include a separate and distinct component that is especially made or especially adapted for use in infringement of the '283 Patent and is not a staple article or commodity of commerce suitable for substantial non-infringing use.

81. As a result of Honda's acts of infringement, Plaintiffs have suffered and will continue to suffer damages in an amount to be proven at trial.

COUNT II

(Honda's Infringement of U.S. Patent No. 9,602,608)

82. Paragraphs 1-81 are incorporated by reference as if fully set forth herein.

83. Honda has directly infringed, and continues to directly infringe, literally and/or by the doctrine of equivalents, individually and/or jointly, the '608 Patent, by making, using, testing, selling, offering for sale and/or importing into the United States vehicles that embody products and/or services that infringe the '608 Patent, including, but not limited to Honda Pilot, Honda Odyssey, Honda Passport, Honda Insight, Honda Accord, Honda Civic Sedan, Honda CR-V, Honda Clarity, Honda Fit, Honda HR-V, Honda Ridgeline, Acura RDX, Acura TLX, Acura NLX, and Acura MDX and other Honda vehicles that are equipped with Honda Navigation System Navigation or similar functionality (collectively, "Honda Count II Automobiles").

84. An exemplary claim, Claim 1 of the '608 Patent, is reproduced below:

The invention claimed is:

1. A electronic computer implemented method for matching users with information, comprising:

receiving a first user preference, a location of a mobile device of the first user, and a geographic area limitation;

storing, for a plurality of objects, a set of attributes of each corresponding object, and a location of the corresponding object;

determining an object of the plurality of objects that matches the first user based on at least:

(a) the set of attributes for the object satisfies the first user preference, and

(b) the distance between the received location of the mobile device of the first user and the object is within the geographic area limitation;

sending to the first user, in response to a positive outcome of the determining, information about the matching object; and
wherein the matching object is a person, place and/or thing.

85. Upon information and belief, the Honda Count II Automobiles are equipped with a navigation system that performs or can perform each and every limitation of at least claim 1 of the '608 Patent, including but not limited to Honda Dynamic Navigation ("Honda Navigation System").

86. Upon information and belief, the Honda Count II Automobiles equipped with Honda Navigation System comprises an electronic computer implemented method for matching users with information.

Having an onboard navigation system makes for great confidence when driving to new places. Use your Honda Satellite-Linked Navigation System™ to find new destinations, get turn-by-turn directions and even show you the way back home by just saying, "Go home!" View this video to see how easy it is.

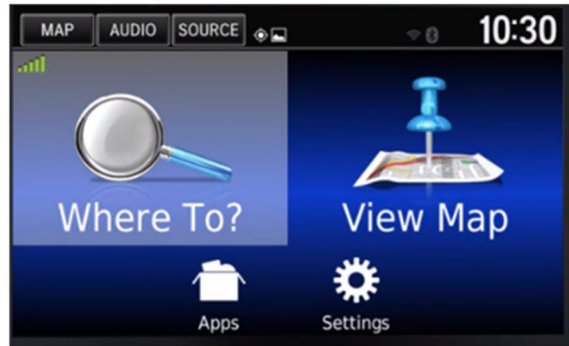

<https://www.hondainfocenter.com/2021/CR-V/How-To-Videos/Touring/Audio-and-Connectivity/How-to-Use-Major-Navigation-System-Features/>

87. Upon information and belief, the Honda Count II Automobiles equipped with Honda Navigation System are capable of receiving a first user preference, a location of a mobile device of the first user, and a geographic area limitation.

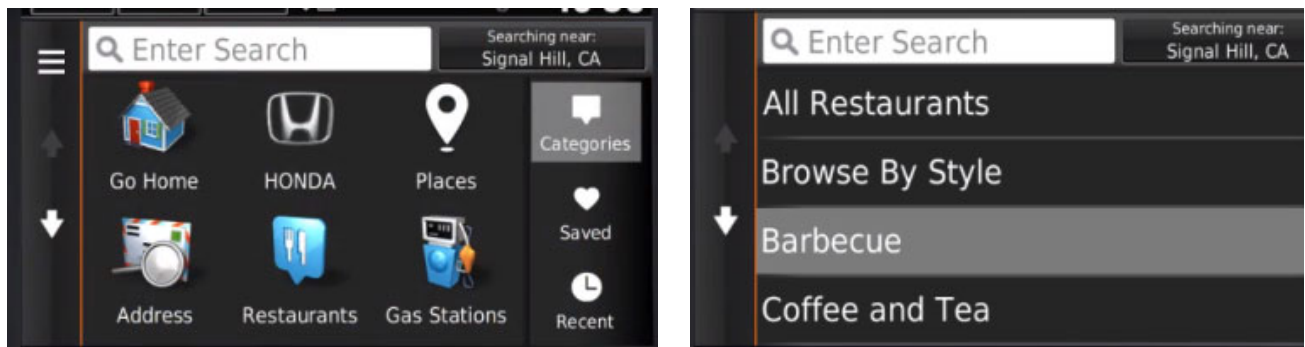

<https://www.hondainfocenter.com/2021/CR-V/How-To-Videos/Touring/Audio-and-Connectivity/How-to-Use-Major-Navigation-System-Features/>

Having an onboard navigation system makes for great confidence when driving to new places. Use your Honda Satellite-Linked Navigation System™ to find new destinations, get turn-by-turn directions and even show you the way back home by just saying, "Go home!" View this video to see how easy it is.

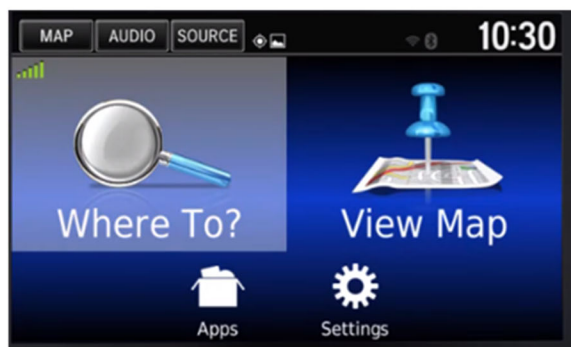

<https://www.hondainfocenter.com/2021/CR-V/How-To-Videos/Touring/Audio-and-Connectivity/How-to-Use-Major-Navigation-System-Features/>

Changing the Search Area

(Map) ► Searching near

By default, your system finds locations closest to your current location. You can find a location near another city or location.

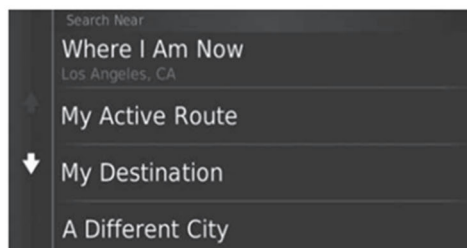

The following options are available:

- **Where I Am Now:** Searches near your current location.

<http://techinfo.honda.com/rjanisis/pubs/OM/AH/ATLA1919NV/enu/ATLA1919NV.PDF> at p. 57.

88. Upon information and belief, the Honda Count II Automobiles equipped with Honda Navigation System are capable of storing, for a plurality of objects, a set of attributes of each corresponding object, and a location of that corresponding object.

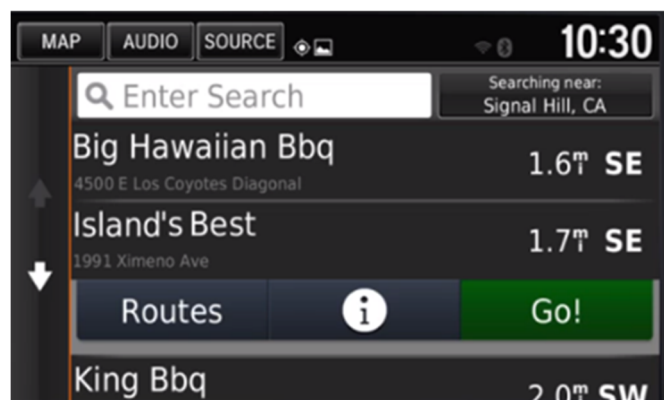
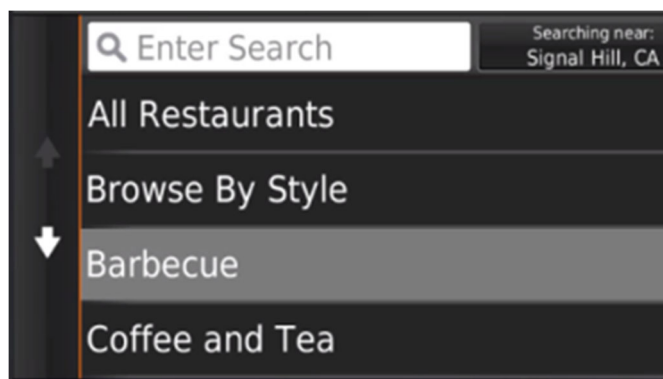

<https://www.hondainfocenter.com/2021/CR-V/How-To-Videos/Touring/Audio-and-Connectivity/How-to-Use-Major-Navigation-System-Features/>

89. Upon information and belief, the Honda Count II Automobiles equipped with Honda Navigation System are capable of determining an object of the plurality of objects in the database that matches the first user based on at least (a) the set of attributes for the object satisfies the first user preference, and (b) the distance between the received location of the mobile device of the first user and the object is within the geographic area limitation.

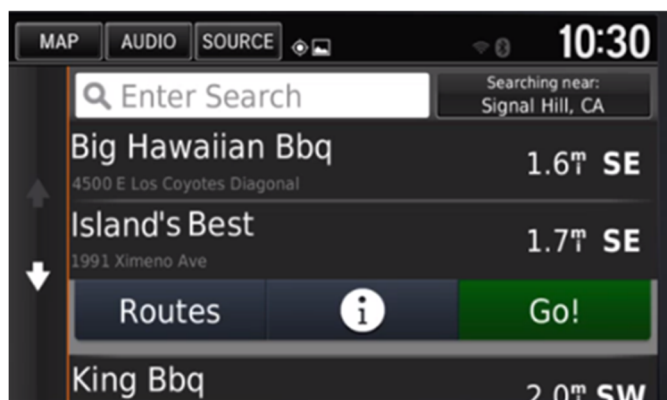
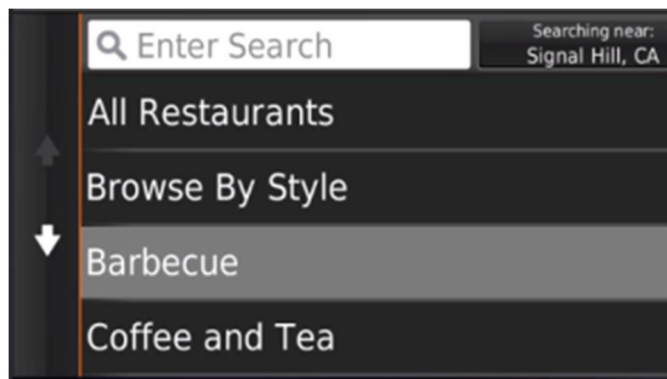

<https://www.hondainfocenter.com/2021/CR-V/How-To-Videos/Touring/Audio-and-Connectivity/How-to-Use-Major-Navigation-System-Features/>

90. Upon information and belief, the Honda Count II Automobiles equipped with Honda Navigation System are capable of sending to the first user, in response to a positive outcome of the determining, information about the matching object; and wherein the matching object is a person, place and/or thing.

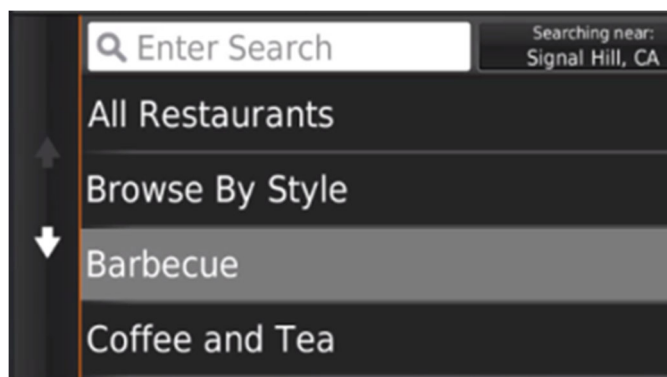

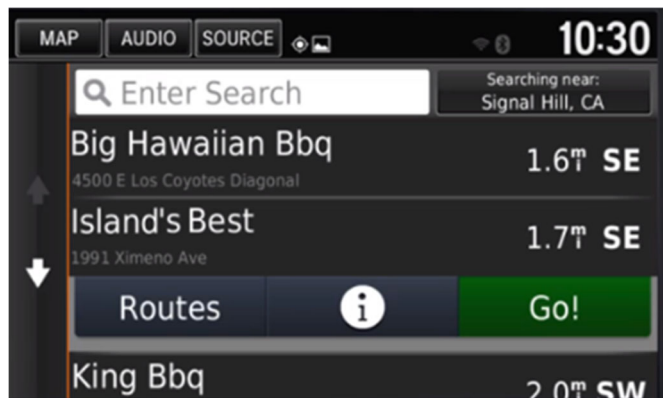

<https://www.hondainfocenter.com/2021/CR-V/How-To-Videos/Touring/Audio-and-Connectivity/How-to-Use-Major-Navigation-System-Features/>

91. Accordingly, Honda is using, offering for sale, or selling in the United States the Honda Count II Automobiles equipped with the Honda Navigation System that directly infringe one or more claims of the '608 Patent.

92. Additionally, Honda has been, and currently is, actively inducing infringement of the '608 Patent under 35 U.S.C. § 271(b) and contributorily infringing the '608 Patent under 35 U.S.C. § 271(c) either literally and/or by the doctrine of equivalents.

93. Honda knew of the '608 Patent, or should have known of the '608 Patent, but was willfully blind to its existence. Honda has had actual knowledge of the '608 Patent since not later than receipt of a letter dated October 18, 2021 and received on the same date. By the time of trial, Honda will have known and intended (since receiving such notice) that its continued actions would infringe and actively induce and contribute to the infringement of one or more claims of the '608 Patent.

94. Honda has committed, and continues to commit, affirmative acts that cause infringement of one or more claims of the '608 Patent with knowledge of the '608 Patent and knowledge or willful blindness that the induced acts constitute infringement of one or more claims of the '608 Patent. As an illustrative example only, Honda induces such acts of infringement by

its affirmative action of providing, promoting, and instructing its customers on how to use the claimed Honda Navigation System in the Honda Count II Automobiles that when used in their normal and customary way as intended and designed by Honda infringe one or more claims of the '608 Patent.

95. Honda has also committed, and continues to commit, contributory infringement by, *inter alia*, knowingly selling products and/or methods or services that when used cause the direct infringement of one or more claims of the '608 Patent by a third party, and which have no substantial non-infringing uses, or include a separate and distinct component that is especially made or especially adapted for use in infringement of the '608 Patent and is not a staple article or commodity of commerce suitable for a substantial non-infringing use.

96. As a result of Honda's acts of infringement, Plaintiffs have suffered and will continue to suffer damages in an amount to be proven trial.

COUNT III

(Honda's Infringement of U.S. Patent No. 7,891,004)

97. Paragraphs 1-96 are incorporated by reference as if fully set forth herein.

98. Honda has directly infringed, and continues to directly infringe, literally and/or by the doctrine of equivalents, individually and/or jointly the '004 Patent, by making, using, testing, selling, offering for sale and/or importing into the United States vehicles that embody products and/or services that infringe the '004 Patent including, but not limited to, the Honda Accord, Honda Odyssey, Honda Passport, Honda Insight, and Honda Pilot (collectively, "Honda Count III Automobiles").¹

¹ See, e.g., <https://hondalink.honda.com/#/compatibility?year=2018&model=Odyssey>; <https://www.hondaoflincoln.com/2018-honda-odyssey-first-minivan-with-4g-lte-in-vehicle-wi-fi-offering-customers-unlimited-data-from-att>;

99. As an exemplary claim, Claim 68 of the '004 Patent, is reproduced below:

68. A method for internetworking, comprising:

coupling, at a gateway node, a plurality of network elements in a motor vehicle, the motor vehicle comprising the gateway node, a first vehicle bus configured to carry communications according to a first communication protocol, a second vehicle bus configured to carry communications according to a second communication protocol, and the plurality of network elements, wherein the plurality of network elements includes a first set of network elements connected to the first vehicle bus, and a second set of network elements connected to the second vehicle bus;

automatically forming a network of the plurality of network elements in which the gateway node provides a bridge between the first vehicle bus and the second vehicle bus, wherein the bridge is operable to pass messages between the first vehicle bus and the second vehicle bus;

coupling at least one network element of the assembled plurality of network elements to a remote computer located outside of the motor vehicle; and

remotely controlling, at the remote computer, at least one function of the assembled plurality of network elements

100. Upon information and belief, Honda Count III Automobiles are equipped with a Mobile Hotspot System that performs or can perform each and every limitation of at least claim 68 of the '004 Patent.

<https://hondalink.honda.com/#/compatibility?year=2019&model=Passport;>
<https://hondalink.honda.com/#/compatibility?year=2019&model=Pilot.>

101. Upon information and belief, the Honda Count III Automobiles are equipped with systems, for example HondaLink®, that use a method for internetworking.²

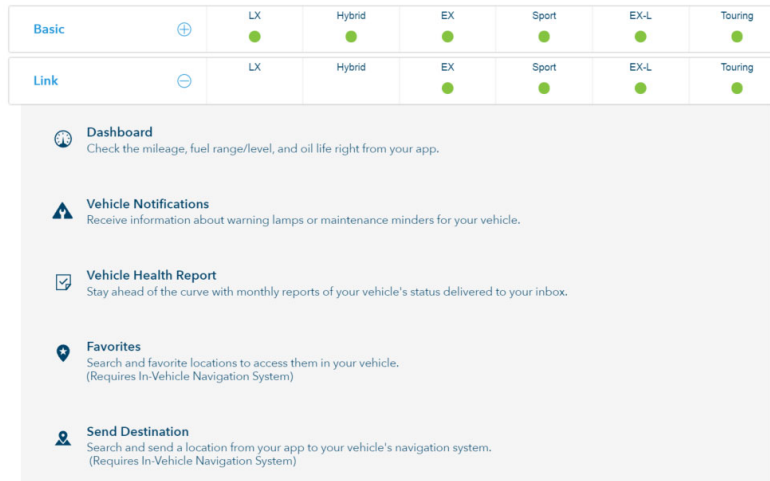

<https://hondalink.honda.com/#/compatibility?year=2018&model=Accord%20Sedan>

102. Upon information and belief, Honda and the Honda Count III Automobiles use and/or include systems, such as HondaLink® that employ coupling, at a gateway node, a plurality of network elements in a motor vehicle, the motor vehicle comprising the gateway node, a first vehicle bus configured to carry communications according to a first communication protocol, a second vehicle bus configured to carry communications according to a second communication protocol, and the plurality of network elements, wherein the plurality of network elements includes a first set of network elements connected to the first vehicle bus, and a second set of network elements connected to the second vehicle bus.

² <https://hondalink.honda.com/#/compatibility?year=2018&model=Accord%20Sedan>

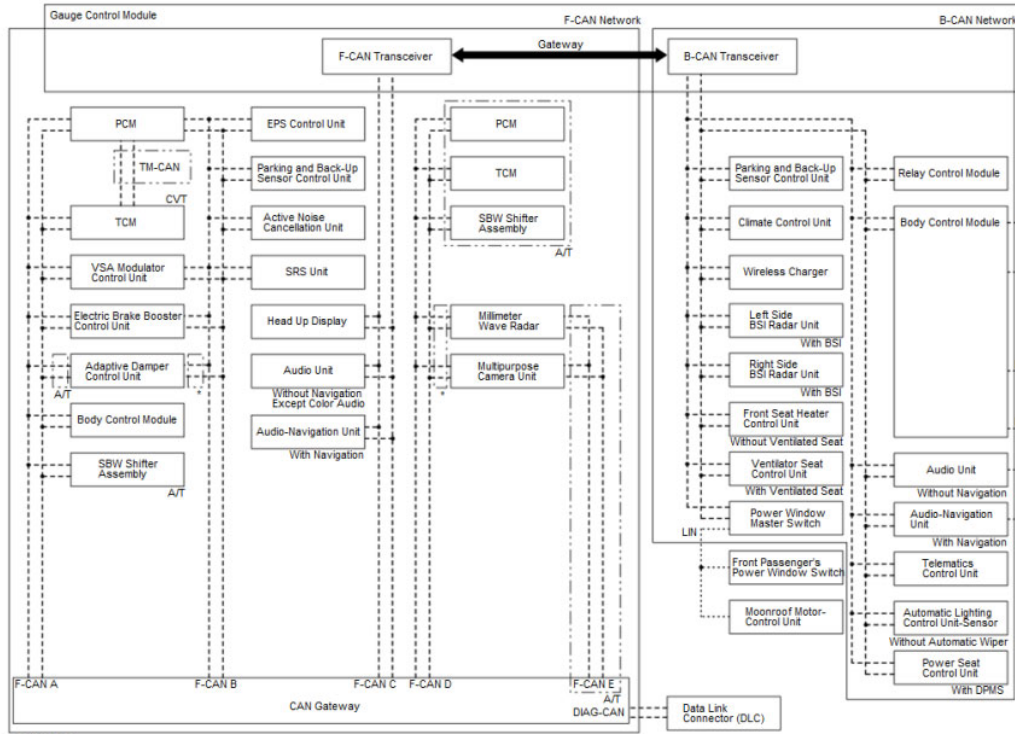

See Exhibit 24, Honda Telematics Control Unit at p. 1.

103. Upon information and belief, Honda and the Honda Count III Automobiles use and/or include systems, such as HondaLink®, that automatically form a network of the plurality of network elements in which the gateway node provides a bridge between the first vehicle bus and the second vehicle bus, wherein the bridge is operable to pass messages between the first vehicle bus and the second vehicle bus.

104. For example, upon information and belief, as shown above, there is a gateway coupling the high speed F-CAN network with the lower speed B-CAN network. Network elements can include, for example, Powertrain Control Module (PCM), Transmission Control Module (TCM), VSA (Vehicle Stability Assist) Modulator Unit in the F-CAN network and Parking and Back-Up Sensor Control Unit, Climate Control Unit and Body Control Module in the B-CAN

network.³ The function of the gateway in this example is a bridge or provides communication of messages between the networks coupled through the gateway, effectively translating F-CAN to B-CAN and B-CAN to F-CAN, as needed.

105. Upon information and belief, Honda and the Honda Count III Automobiles use and/or include systems, such as HondaLink®, that couples at least one network element of the assembled plurality of network elements to a remote computer located outside of the motor vehicle.

106. Upon information and belief, Honda and the Honda Count III Automobiles use and/or include a Telematics Control Unit that provides coupling to a remote computer.

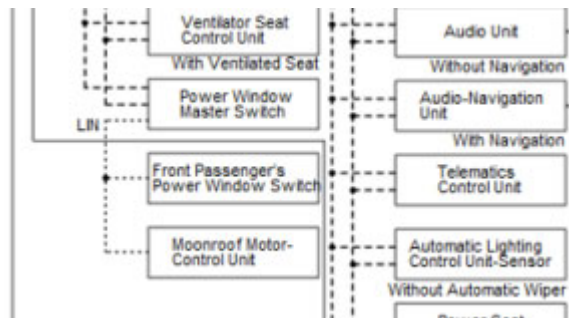

See Exhibit 24, Honda Telematics Control Unit at p. 1.

107. Upon information and belief, Honda and the Honda Count III Automobiles use features, including for example, Personal Data Wipe, to remotely control, using the remote computer, at least one function of the assembled plurality of network elements.⁴

³ *Id.*

⁴ <https://www.viphonda.com/manufacture-information/hondalink-and-honda-sensing-technology/>

What is HondaLink®?

With the HondaLink® app downloaded to your phone, you can stay connected and enjoy the convenience of viewing vehicle information on the go, sending maps from phone to car, and more. You'll find HondaLink® available across the latest Honda lineup of cars and SUVs, including the **Honda HR-V** and **Honda Civic Hatchback**.

You'll also enjoy several peace-of-mind features, including:

- **Automatic Collision Notification:** If you're involved in a crash, an agent will automatically check-in. If you don't respond, they'll request emergency assistance.
- **Enhanced Roadside Assistance:** Provides live responsive help with towing and repair services.
- **Emergency Call:** If you're involved in an emergency, trained agents will be ready to delivery priority attention and request assistance.
- **Personal Data Wipe:** If your vehicle is stolen, remotely reset your navigation system to clear any stored information.



<https://hondalink.honda.com/#/>

108. Accordingly, Honda is using, offering for sale, or selling in the United States the Honda Count III Automobiles equipped with HondaLink® that directly infringe one or more claims of the '004 Patent.

109. Additionally, Honda has been, and currently is, actively inducing infringement of the '004 Patent under 35 U.S.C. § 271(b) and contributorily infringing the '004 Patent under 35 U.S.C. § 271(c) either literally and/or by the doctrine of equivalents.

110. Honda knew of the '004 Patent, or should have known of the '004 Patent, but was willfully blind to its existence. Honda has had actual knowledge of the '004 Patent since not later than receipt of a letter dated October 18, 2021 and received on the same date. By the time of trial, Honda will have known and intended (since receiving such notice) that its continued actions would infringe and actively induce and contribute to the infringement of one or more claims of the '004 Patent.

111. Honda has committed, and continues to commit, affirmative acts that cause infringement of one or more claims of the '004 Patent with knowledge of the '004 Patent and knowledge or willful blindness that the induced acts constitute infringement of one or more claims of the '004 Patent. As an illustrative example only, Honda induces such acts of infringement by

its affirmative action of providing, promoting, and instructing its customers on how to use HondaLink® in the Honda Count III Automobiles that when used in their normal and customary way as intended and designed by Honda, infringe one or more claims of the '004 Patent.

112. Honda has also committed, and continues to commit, contributory infringement, by *inter alia*, knowingly selling products and/or methods or services that when used cause the direct infringement of one or more claims of the '004 Patent by a third party, and which have no substantial non-infringing uses, or include a separate and distinct component that is especially made or especially adapted for use in infringement of the '004 Patent and is not a staple article or commodity of commerce suitable for a substantial non-infringing use.

113. As a result of Honda's acts of infringement, Plaintiffs have suffered and will continue to suffer damages in an amount to be proven at trial.

COUNT IV

(Honda's Infringement of U.S. Patent No. 9,291,475)

114. Paragraphs 1-113 are incorporated by reference as if fully set forth herein.

115. Honda has directly infringed, and continues to directly infringe, literally and/or by the doctrine of equivalents, individually and/or jointly, the '475 Patent, by making, using, testing, selling, offering for sale and/or importing into the United States vehicles that embody products and/or services that infringe the '475 Patent including, but not limited to, the Honda Accord, Honda Odyssey, Honda Passport, and Honda Insight (collectively, "Honda Count IV Automobiles").⁵

116. As an exemplary claim, Claim 15 of the '475 Patent is reproduced below:

15. A device for notifying a recipient of a violation by a driver of a vehicle, the device comprising:

⁵ See, e.g., <https://hondalink.honda.com/#/compatibility?year=2018&model=Odyssey>; <https://hondalink.honda.com/#/compatibility?year=2019&model=Pilot>.

an information module configured to determine, while the device is located within a vehicle, information about the vehicle;

a processing module configured to determine, while the device is located within the vehicle, that the vehicle committed a violation based on the information about the vehicle; and

a transmission module configured to send, to a remote computing system while the device is located within the vehicle, an indication of the violation;

wherein the remote computing device is configured to notify a recipient about the violation committed by the vehicle.

117. Upon information and belief, Honda and/or Honda Count IV Automobiles perform or can perform each and every limitation of at least claim 15 of the '475 Patent.

118. For example, the Honda Count IV Automobiles include and use a device, for example, HondaLink®, for notifying a recipient of a violation by a driver of a vehicle.

Connect with Your Vehicle

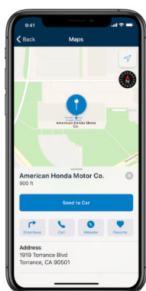

Dashboard

View up-to-date mileage, fuel level, and oil life readings for your vehicle.



Vehicle Notifications

Receive alerts when a warning light comes on or if it's time to schedule maintenance.



Send Destination

Search for destinations on your phone and instantly beam turn-by-turn directions to your navigation system.



Favorites

Save your favorite destinations to the app and easily send them to your vehicle.

See <https://hondalink.honda.com/#>.

119. Upon information and belief, the Honda Count IV Automobiles with HondaLink® include an information module configured to determine, while the device is located within a

vehicle, information about the vehicle.⁶

- *Information about Use of Connected Vehicle Technologies and Services* such as
 - Search content;
 - HondaLink or AcuraLink account access information, including information about anyone making a call using the Connected Vehicle Technologies and Services;
 - Call history information, including the date, time, and duration of a call, and any response specialist's notes written during a call;
 - Navigation system settings and usage;
 - Audio system settings and usage;
 - Voice commands given (which may include audio recordings);
 - Connectivity systems (e.g., embedded TCU, Wi-Fi hotspot) settings and usage;
- *Geolocation Information* meaning the exact location of your vehicle at a specific point in time or over a period of time;
- *Driver Behavior Information* such as vehicle speed, vehicle acceleration and deceleration, pedal positions, engine speed, direction of travel, time of travel, steering angle, yaw rate, vehicle control systems settings/position/usage, Honda Sensing/Acura Watch system settings and usage.

Although the vehicle generates and wirelessly transmits to us much of the Covered Information automatically, we also collect Covered Information when you contact us or our service providers regarding Connected Vehicle Technologies and Services, subscribe to the Connected Vehicle Technologies and Services, use smart device applications associated with Connected Vehicle Technologies and Services, and at times when you provide Covered Information directly to us or our service providers.

See <https://hondalink.honda.com/#/>.

120. Upon information and belief, the Honda Count IV Automobiles with HondaLink® include a processing module configured to determine, while the device is located within the vehicle, that the vehicle committed a violation based on the information about the vehicle. Upon information and belief, the Honda Count IV Automobiles with HondaLink® determine the vehicle information such as speed and location.⁷

⁶ https://www.honda.com/-/media/Honda-Homepage/PDF/American_Honda_Motor_Vehicle_Technology_Data_Privacy.pdf.

⁷ https://www.honda.com/-/media/Honda-Homepage/PDF/American_Honda_Motor_Vehicle_Technology_Data_Privacy.pdf

Geolocation and Driver Behavior Information. Certain of the Connected Vehicle Technologies and Services may collect geolocation and driver behavior information.

- Geolocation information means the exact location of your vehicle, either at a specific point in time or over a period of time. Under certain circumstances, your vehicle may send an electronic signal with your latitude and longitude at a particular point in time to Honda or our third party service provider. For example, if your vehicle is in a crash or you press the Assist button in your
- Driver behavior information collected by our Connected Vehicle Technologies and Services includes (or can include some or all of): vehicle speed; vehicle acceleration and deceleration (and associated pedal positions);, engine speed;,, direction of travel; time of travel; steering

Geolocation Information: Covered Information about the precise geographic location of a vehicle.

<https://www.honda.ca/privacy/vehicledata>; <https://www.honda.com/privacy/connected-product-privacy-policy.pdf>

121. Upon information and belief, the Honda Count IV Automobiles with HondaLink® determine, for example, that the driver is driving with a higher speed (violation).

122. Upon information and belief, the Honda Count IV Automobiles with the HondaLink system include a transmission module configured to send, to a remote computing system while the device is located within the vehicle, an indication of the violation, wherein the remote computing device is configured to notify a recipient about the violation committed by the vehicle. As a further example, the HondaLink system provides alerts, for example when the vehicle exceeds a certain speed, to or from a remote systems or devices via LTE transmission.⁸



GEOFENCE ALERT

Keep tabs on your vehicle's location with alerts that notify you when it enters or leaves a designated area.



Security Alarm Alert

Receive timely alerts when your vehicle alarm is triggered.

⁸ <https://www.qualcomm.com/news/releases/2018/01/08/qualcomm-powers-advanced-connected-car-technologies-2018-honda-accord>; <https://hondalink.honda.com/#/>

<https://hondalink.honda.com/#/>

123. Accordingly, Honda is using, offering for sale, or selling in the United States the Honda Count IV Automobiles with HondaLink® that directly infringe one or more claims of the '475 Patent.

124. Additionally, Honda has been, and currently is, actively inducing infringement of the '475 Patent under 35 U.S.C. § 271(b) and contributorily infringing the '475 Patent under 35 U.S.C. § 271(c) either literally and/or by the doctrine of equivalents.

125. Honda knew of the '475 Patent, or should have known of the '475 Patent, but was willfully blind to its existence. Honda has had actual knowledge of the '475 Patent since not later than receipt of a letter dated October 18, 2021 and received on the same date. By the time of trial, Honda will have known and intended (since receiving such notice) that its continued actions would infringe and actively induce and contribute to the infringement of one or more claims of the '475 Patent.

126. Honda has committed, and continues to commit, affirmative acts that cause infringement of one or more claims of the '475 Patent with knowledge of the '475 Patent and knowledge or willful blindness that the induced acts constitute infringement of one or more claims of the '475 Patent. As an illustrative example only, Honda induces such acts of infringement by its affirmative action of providing, promoting, and instructing its customers on how to use HondaLink® in the Honda Count IV Automobiles that when used in their normal and customary way as intended and designed by Honda, infringe one or more claims of the '475 Patent.

127. Honda has also committed, and continues to commit, contributory infringement, by *inter alia*, knowingly selling products and/or methods or services that when used cause the direct infringement of one or more claims of the '475 Patent by a third party, and which have no

substantial non-infringing uses, or include a separate and distinct component that is especially made or especially adapted for use in infringement of the '475 Patent and is not a staple article or commodity of commerce suitable for a substantial non-infringing use.

128. As a result of Honda's acts of infringement, Plaintiffs have suffered and will continue to suffer damages in an amount to be proven at trial.

COUNT V

(Honda's Infringement of U.S. Patent No. 7,382,771)

129. Paragraphs 1-128 are incorporated by reference as if fully set forth herein.

130. Honda has directly infringed, and continues to directly infringe, literally and/or by the doctrine of equivalents, individually and/or jointly, the '771 Patent, by making, using, testing, selling, offering for sale and/or importing into the United States vehicles that embody products and/or services that infringe the '771 Patent including, but not limited to, the Honda Pilot, Honda Odyssey, Honda Passport, Honda Insight, Honda Accord, Honda Civic Sedan, Honda CR-V, Honda Clarity, Honda Fit, Honda HR-V, Honda Ridgeline, Acura RDX, Acura TLX, Acura NLX, and Acura MDX that are equipped with and use the In-Vehicle Wi-Fi and/or similar mobile wireless hotspot ("Mobile Hotspot System") functionality (collectively, "Honda Count V Automobiles").

131. An exemplary claim, claim 1 of the '771 Patent is reproduced below:

1. A mobile wireless hot spot system, comprising:

a) a short-range, high-speed wireless access point operative to communicate with short-range client devices;

b) a long-range, wireless Internet access interface operative to communicate with the Internet; and

c) a Local Area Network (LAN) routing system managing the data path between

said wireless access point and said Internet access interface, wherein said mobile wireless hotspot system is a stand-alone system that enables client devices configured for short-range, high-speed wireless Internet access to use said mobile wireless hotspot system to access the Internet without the need to access an external service controller server.

132. Upon information and belief, the Honda Count V Automobiles are equipped with a Mobile Hotspot System that performs or can perform each and every limitation of at least claim 1 of the '771 Patent.

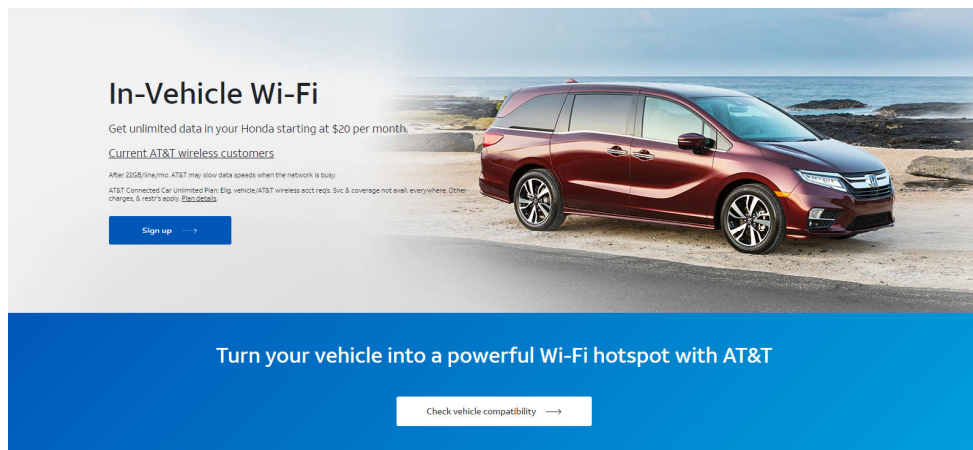

<https://www.att.com/plans/connected-car/honda/>

133. Upon information and belief, Honda's Mobile Hotspot System includes a short-range, high-speed wireless access point operative to communicate with short-range client devices, such as mobile phones or tablets. For example, Honda's Mobile Hotspot System allows users to connect to the Internet through Wi-Fi.

134. Upon information and belief, Honda's Mobile Hotspot system includes a long-range, wireless Internet access interface operative to communicate with the Internet through AT&T, Verizon Wireless, and/or other Internet providers.

135. Upon information and belief, Honda's Mobile Hotspot System includes a Local

Area Network (LAN) routing system, which manages the data path between the wireless access point and the Internet access interface. Upon information and belief, Honda's Mobile Hotspot System is a stand-alone system that allows client devices to access the Internet, for example, through Wi-Fi, and connect to high-speed wireless Internet, including 4G. Upon information and belief, Honda's Mobile Hotspot System enables client devices configured for short-range, high-speed wireless Internet access to use said mobile wireless hotspot system to access the Internet without the need to access an external service controller server. As a result, user devices such as mobile phones and tablets are capable of accessing the Internet through Honda's Mobile Hotspot System without having to rely on the user device's own cellular capability to access the Internet.

136. Accordingly, Honda is using, offering for sale, or selling in the United States the Honda Count V Automobiles equipped with a Mobile Hotspot System that directly infringe one or more claims of the '771 Patent.

137. Additionally, Honda has been, and currently is, actively inducing infringement of the '771 Patent under 35 U.S.C. § 271(b) and contributorily infringing the '771 Patent under 35 U.S.C. § 271(c) either literally and/or by the doctrine of equivalents.

138. Honda knew of the '771 Patent, or should have known of the '771 Patent, but was willfully blind to its existence. Honda has had actual knowledge of the '771 Patent since not later than receipt of a letter dated October 18, 2021 and received on the same date. By the time of trial, Honda will have known and intended (since receiving such notice) that its continued actions would infringe and actively induce and contribute to the infringement of one or more claims of the '771 Patent.

139. Honda has committed, and continues to commit, affirmative acts that cause infringement of one or more claims of the '771 Patent with knowledge of the '771 Patent and

knowledge or willful blindness that the induced acts constitute infringement of one or more claims of the '771 Patent. As an illustrative example only, Honda induces such acts of infringement by its affirmative action of providing, promoting, and instructing its customers on how to use the claimed Mobile Hotspot System in the Honda Count V Automobiles that when used in their normal and customary way as intended and designed by Honda, infringe one or more claims of the '771 Patent.

140. Honda has also committed, and continues to commit, contributory infringement by, *inter alia*, knowingly selling products and/or methods or services that when used cause the direct infringement of one or more claims of the '771 Patent by a third party, and which have no substantial non-infringing uses, or include a separate and distinct component that is especially made or especially adapted for use in infringement of the '771 Patent and is not a staple article or commodity of commerce suitable for a substantial non-infringing use.

141. As a result of Honda's acts of infringement, Plaintiffs have suffered and will continue to suffer damages in an amount to be proven at trial.

COUNT VI

(Honda's Infringement of U.S. Patent No. 9,232,158)

142. Paragraphs 1-141 are incorporated by reference as if fully set forth herein.

143. Honda has directly infringed, and continues to directly infringe, literally and/or by the doctrine of equivalents, individually and/or jointly, the '158 Patent, by making, using, testing, selling, offering for sale and/or importing into the United States vehicles that embody products and/or services that infringe the '158 Patent including, but not limited to, the Acura MDX and Acura RDX models that are equipped with Surround-View (collectively, the "Honda Count VI Automobiles").

144. An exemplary claim, claim 9 of the '158 Patent, is reproduced below:

9. *A system comprising:*

a plurality of channels, wherein each channel of the plurality of channels includes a sensor; and

a processing component coupled to the plurality of channels, wherein the processing component is configured to determine an integration time of each channel of the plurality of channels, wherein the processing component is configured to combine data from the plurality of channels received to provide an image.

145. Upon information and belief, the Honda Count VI Automobiles perform each and every limitation of at least claim 9 of the '158 Patent.

146. Upon information and belief, the Honda Count VI Automobiles are equipped with a processing component that determines the integration time of multiple channels and combines data to provide an image as claimed in the '158 Patent.



<https://beta.acuranews.com/en-US/releases/release-0d4299c7fc28e9f9054be9d007166845/photos/59>

147. Upon information and belief, Surround-View includes a plurality of channels,

wherein each channel of the plurality of channels includes a sensor. Upon information and belief, Surround View uses four exterior cameras to display a 360° degree view of the area around the vehicle.

148. Upon information and belief, Surround-View includes a processing component coupled to the plurality of channels, wherein the processing component is configured to determine an integration time of each channel of the plurality of channels, wherein the processing component is configured to combine data from the plurality of channels received to provide an image. Upon information and belief, Surround-View includes hardware and software that combines the images from the cameras to create a combined image displaying a 360° view of the vehicle.

Surround-View Camera

Park more easily in tough spots, with the Advance Package's Surround-View Camera System. Four exterior cameras together give you a 360 view of the space immediately around the car through the navigation display. A camera button among the nav display controls or an even more conveniently located button on the end of the turn signal lever changes camera views.

- Select Reverse, and you are automatically given the traditional rear camera view, plus an overhead 360 view. Guidelines appear in each view and correspond with the angle of the front wheels angle to show your rearward path. A press of either camera button switches to show the rear view alone, and another press shows a wide-angle rear view.
- Pressing either "Camera" button when not in reverse shows the 360 view combined with a front view that is ideal for getting that perfect position in the garage. Another button press provides you with a front wide-angle view that is useful for helping you spot an approaching vehicle or person when nosing out a tight spot with a blocked side view.
- Additional views include looking ahead from both sides and just the passenger side view alone.



<https://www.acura.com/mdx/modals/surround-view-camera>

149. Accordingly, Honda is using, offering for sale, or selling in the United States the Honda Count VI Automobiles equipped with Surround-View that directly infringe one or more claims of the '158 Patent.

150. Additionally, Honda has been, and currently is, actively inducing infringement of the '158 Patent under 35 U.S.C. § 271(b) and contributorily infringing the '158 Patent under 35

U.S.C. § 271(c) either literally and/or by the doctrine of equivalents.

151. Honda knew of the '158 Patent, or should have known of the '158 Patent, but was willfully blind to its existence. Honda has had actual knowledge of the '158 Patent since not later than receipt of a letter dated October 18, 2021 and received on the same date. By the time of trial, Honda will have known and intended (since receiving such notice) that its continued actions would infringe and actively induce and contribute to the infringement of one or more claims of the '158 Patent.

152. Honda has committed, and continues to commit, affirmative acts that cause infringement of one or more claims of the '158 Patent with knowledge of the '158 Patent and knowledge or willful blindness that the induced acts constitute infringement of one or more claims of the '158 Patent. As an illustrative example only, Honda induces such acts of infringement by its affirmative action of providing, promoting, and instructing its customers on how to use Surround-View in the Honda Count VI Automobiles that when used in their normal and customary way as intended and designed by Honda, infringe one or more claims of the '158 Patent.⁹

153. Honda has also committed, and continues to commit, contributory infringement by, *inter alia*, knowingly selling products and/or methods or services that when used cause the direct infringement of one or more claims of the '158 Patent by a third party, and which have no substantial non-infringing uses, or include a separate and distinct component that is especially made or especially adapted for use in infringement of the '158 Patent and is not a staple article or commodity of commerce suitable for a substantial non-infringing use.

⁹ See <http://techinfo.honda.com/rjanisis/pubs/OM/AH/ATLA2121NV/enu/ATLA2121NV.PDF>; <http://techinfo.honda.com/rjanisis/pubs/OM/AH/ATVA2121NV/enu/ATVA2121NV.PDF>; <http://techinfo.honda.com/rjanisis/pubs/OM/AH/ATRW2121NM/enu/ATRW2121NM.PDF>; <http://techinfo.honda.com/rjanisis/pubs/OM/AH/AT7A2121NM/enu/AT7A2121NM.PDF>.

154. As a result of Honda's acts of infringement, Plaintiffs have suffered and will continue to suffer damages in an amount to be proven at trial.

COUNT VII

(Honda's Infringement of U.S. Patent No. 9,681,466)

155. Paragraphs 1-154 are incorporated by reference as if fully set forth herein.

156. Honda has directly infringed, and continues to directly infringe, literally and/or by the doctrine of equivalents, individually and/or jointly, the '466 Patent, by making, using, testing, selling, offering for sale and/or importing into the United States vehicles that embody products and/or services that infringe the '466 Patent including, but not limited to, the Honda Accord, Odyssey, Passport, and Insight that use Honda's Mobile Hotspot System and/or HondaLink® (collectively, "Honda Count VII Automobiles").¹⁰

157. As an exemplary claim, Claim 1 of the '466 Patent is reproduced below:

1. A user equipment (UE) comprising:

circuitry configured to receive, from a network device, a first transmission including a first parameter corresponding to each of a plurality of channels and a second transmission including an allocation message for an uplink resource from the network device;

a processor configured to allocate resources in response to the allocation message, wherein resources are allocated for data of each channel having a second parameter above zero prior to another channel's data for transmission having a

¹⁰ See, e.g., <https://hondalink.honda.com/#!/compatibility?year=2018&model=Odyssey>; <https://www.hondaoflincoln.com/2018-honda-odyssey-first-minivan-with-4g-lte-in-vehicle-wi-fi-offering-customers-unlimited-data-from-att>; <https://hondalink.honda.com/#!/compatibility?year=2019&model=Passport>; <https://hondalink.honda.com/#!/compatibility?year=2019&model=Pilot>.

third parameter less than or equal to zero; and

wherein the second parameter is derived from a first channel's first parameter and the third parameter is derived from a second channel's first parameter.

158. Upon information and belief, the Honda Count VII Automobiles perform each and every limitation of at least claim 1 of the '466 Patent.

159. Upon information and belief, the Honda Count VII Automobiles include Qualcomm's 4G LTE modem, which includes a Snapdragon Automotive platform, to support Honda's Mobile Hotspot System and HondaLink®. Upon information and belief, the Honda Count VII Automobiles' Mobile Hotspot System and HondaLink® provide a system wherein a user can connect with 4G LTE to the Internet.¹¹

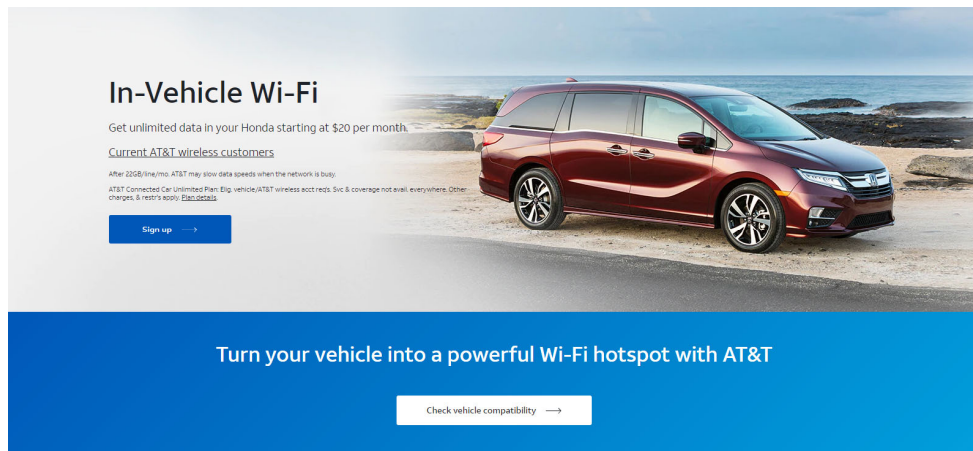

<https://www.att.com/plans/connected-car/honda/>

¹¹ <https://www.prnewswire.com/news-releases/att-and-american-honda-enter-connected-car-agreement-300385547.html>

Touring 2.0T includes the following features and more:

- Low-Speed Braking Control*
- Ventilated Front Seats
- Heated Outboard Rear Seats
- Head-Up Display (HUD)
- Adaptive Damper System
- Wireless Phone Charger*
- Wi-Fi Hotspot Capability*
- Honda Satellite-Linked Navigation System™*
- Rain-Sensing Windshield Wipers
- LED Headlights with Auto-On/Off
- Interior Ambient Lighting
- Body-Colored Parking Sensors (Front/Rear)
- Side Mirrors with Reverse Gear Tilt-Down
- HondaLink® Subscription Services*

<https://automobiles.honda.com/accord-sedan/specs-feature-modals/touring-features>

Qualcomm Technologies, Inc. (QTI), a subsidiary of Qualcomm Incorporated (NASDAQ: QCOM), announced today its continued support for cutting-edge personalization, infotainment and telematics systems, as demonstrated with the recent launch of the 2018 Honda Accord. The 2018 Honda Accord features a highly advanced Snapdragon Automotive Platform to power cutting-edge applications for its in-vehicle infotainment and navigation system. Snapdragon automotive solutions are designed to support automotive manufacturers' efforts to provide rich, intuitive experiences to consumers. As part of Qualcomm Technologies' efforts to offer widespread support for automotive manufacturers implementations of the connected car the 2018 Honda Accord also features a Qualcomm® 4G LTE modem which is designed to support the Hondalink™ vehicle connectivity system.

<https://www.qualcomm.com/news/releases/2018/01/08/qualcomm-powers-advanced-connected-car-technologies-2018-honda-accord>

160. Upon information and belief, the Honda Count VII Automobiles' Mobile Hotspot, HondaLink®, and/or 4G LTE modem are compliant with and use the 3GPP standards.

161. The Honda Count VII Automobiles contain user equipment (UE).¹²

¹² <https://www.qualcomm.com/news/releases/2018/01/08/qualcomm-powers-advanced-connected-car-technologies-2018-honda-accord>; <https://automobiles.honda.com/accord-sedan>; <https://hondalink.honda.com/#/>

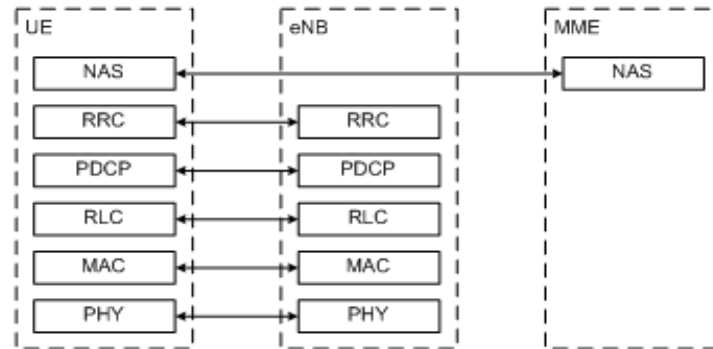

Figure 4.3.2-1: Control-plane protocol stack

See Exhibit 13, 3GPP TS 36.300 V8.12.0 at p. 19.

7.2 RRC protocol states & state transitions

- At PDCP/RLC/MAC level:
 - UE can transmit and/or receive data to/from network;
 - UE monitors control signalling channel for shared data channel to see if any transmission over the shared data channel has been allocated to the UE;

See Exhibit 13, 3GPP TS 36.300 V8.12.0 at pp. 37, 38.

162. The Honda Count VII Automobiles contain circuitry configured to receive, from a network device, a first transmission including a first parameter corresponding to each of a plurality of channels and a second transmission including an allocation message for an uplink resource from the network device.

4.4 Functions

The RRC protocol includes the following main functions:

- QoS control including assignment/ modification of semi-persistent scheduling (SPS) configuration information for DL and UL, assignment/ modification of parameters for UL rate control in the UE, i.e. allocation of a priority and a prioritised bit rate (PBR) for each RB;

See Exhibit 14, 3GPP TS 36.331 V8.21.0 at p. 19.

11.1 Basic Scheduler Operation

MAC in eNB includes dynamic resource schedulers that allocate physical layer resources for the DL-SCH and UL-SCH transport channels. Different schedulers operate for the DL-SCH and UL-SCH.

See Exhibit 13, 3GPP TS 36.300 V8.12.0 at p. 67.

11.1.2 Uplink Scheduling

In the uplink, E-UTRAN can dynamically allocate resources (PRBs and MCS) to UEs at each TTI via the C-RNTI on PDCCH(s). A UE always monitors the PDCCH(s) in order to find possible allocation for uplink transmission when its downlink reception is enabled (activity governed by DRX when configured).

See id.

163. Upon information and belief, the Honda Count VII Automobiles include a processor configured to allocate resources in response to the allocation message, wherein resources are allocated for data of each channel having a second parameter above zero prior to another channel's data for transmission having a third parameter less than or equal to zero.

4.2.1 MAC Entities

E-UTRA defines two MAC entities; one in the UE and one in the E-UTRAN. These MAC entities handle the following transport channels:

- Uplink Shared Channel(s) (UL-SCH);
- Random Access Channel(s) (RACH);

See Exhibit 15, 3GPP TS 36.321 V8.12.0 at p. 8.

5.4.1 UL Grant reception

In order to transmit on the UL-SCH the UE must have a valid uplink grant (except for non-adaptive HARQ retransmissions) which it may receive dynamically on the PDCCH or in a Random Access Response or which may be configured semi-persistently. To perform requested transmissions, the MAC layer receives HARQ information from

See Exhibit 15, 3GPP TS 36.321 V8.12.0 at p. 20.

5.4.3 Multiplexing and assembly

5.4.3.1 Logical channel prioritization

The UE shall perform the following Logical Channel Prioritization procedure when a new transmission is performed:

- The UE shall allocate resources to the logical channels in the following steps:
 - Step 1: All the logical channels with $B_j > 0$ are allocated resources in a decreasing priority order. If the PBR of a radio bearer is set to "infinity", the UE shall allocate resources for all the data that is available for transmission on the radio bearer before meeting the PBR of the lower priority radio bearer(s);
 - Step 2: the UE shall decrement B_j by the total size of MAC SDUs served to logical channel j in Step 1

See Exhibit 15, 3GPP TS 36.321 V8.12.0 at p. 24.

164. Upon information and belief, Honda Count VII Automobiles contain a system

wherein the second parameter is derived from a first channel's first parameter and the third parameter is derived from a second channel's first parameter.

5.4.3 Multiplexing and assembly

5.4.3.1 Logical channel prioritization

RRC controls the scheduling of uplink data by signalling for each logical channel: *priority* where an increasing *priority* value indicates a lower priority level, *prioritisedBitRate* which sets the Prioritized Bit Rate (PBR), *bucketSizeDuration* which sets the Bucket Size Duration (BSD).

The UE shall maintain a variable B_j for each logical channel j . B_j shall be initialized to zero when the related logical channel is established, and incremented by the product $PBR \times TTI$ duration for each TTI, where PBR is Prioritized Bit Rate of logical channel j . However, the value of B_j can never exceed the bucket size and if the value of B_j is larger than the bucket size of logical channel j , it shall be set to the bucket size. The bucket size of a logical channel is equal to $PBR \times BSD$, where PBR and BSD are configured by upper layers.

See Exhibit 15, 3GPP TS 36.321 V8.12.0 at p. 24.

165. Accordingly, Honda is using, offering for sale, or selling in the United States the Honda Count VII Automobiles equipped with a Mobile Hotspot System, HondaLink®, and/or 4G LTE modem that directly infringe one or more claims of the '466 Patent.

166. Additionally, Honda has been, and currently is, actively inducing infringement of the '466 Patent under 35 U.S.C. § 271(b) and contributorily infringing the '466 Patent under 35 U.S.C. § 271(c) either literally and/or by the doctrine of equivalents.

167. Honda knew of the '466 Patent, or should have known of the '466 Patent, but was willfully blind to its existence. Honda has had actual knowledge of the '466 Patent since not later than receipt of a letter dated October 18, 2021 and received on the same date. By the time of trial, Honda will have known and intended (since receiving such notice) that its continued actions would infringe and actively induce and contribute to the infringement of one or more claims of the '466 Patent.

168. Honda has committed, and continues to commit, affirmative acts that cause infringement of one or more claims of the '466 Patent with knowledge of the '466 Patent and

knowledge or willful blindness that the induced acts constitute infringement of one or more claims of the '466 Patent. As an illustrative example only, Honda induces such acts of infringement by its affirmative action of providing, promoting, and instructing its customers on how to use the claimed HondaLink® and connectivity features in the Honda Count VII Automobiles that when used in their normal and customary way as intended and designed by Honda, infringe one or more claims of the '466 Patent.

169. Honda has also committed, and continues to commit, contributory infringement, by *inter alia*, knowingly selling products and/or methods or services that when used cause the direct infringement of one or more claims of the '466 Patent by a third party, and which have no substantial non-infringing uses, or include a separate and distinct component that is especially made or especially adapted for use in infringement of the '466 Patent and is not a staple article or commodity of commerce suitable for a substantial non-infringing use.

170. As a result of Honda's acts of infringement, Plaintiffs have suffered and will continue to suffer damages in an amount to be proven at trial.

COUNT VIII

(Honda's Infringement of U.S. Patent No. 10,292,138)

171. Paragraphs 1-170 are incorporated by reference as if fully set forth herein.

172. Honda has directly infringed, and continues to directly infringe, literally and/or by the doctrine of equivalents, individually and/or jointly, the '138 Patent, by making, using, testing, selling, offering for sale and/or importing into the United States vehicles that embody products and/or services that infringe the '138 Patent including, but not limited to, the Honda Accord, Honda Pilot, Honda Odyssey, and Honda Insight, that use a Mobile Hotspot System and/or HondaLink® (collectively, "Honda Count VIII Automobiles").

173. An exemplary claim, claim 1 of the '138 Patent is reproduced below:

1. A user equipment (UE) comprising:

a processor communicatively coupled to a transmitter and circuitry configured to receive; and

the processor is configured to:

cause the circuitry to receive parameters associated with a plurality of radio bearers,

determine a plurality of buffer occupancies, wherein each of the plurality of buffer occupancies is associated with one or more radio bearers of the plurality of radio bearers,

cause the transmitter to transmit a message including the plurality of buffer occupancies to a network,

cause the circuitry to receive a single allocation of uplink resources,

select data from the plurality of radio bearers for transmission using the single allocation of uplink resources, wherein the selection of the data occurs using a first iteration and a second iteration,

wherein in the first iteration, the selection of the data is selected from a subset of the plurality of radio bearers based on the received parameters,

wherein in the second iteration, the selection of the data is based on buffered data for respective radio bearers, and

cause the transmitter to transmit a signal including the selected data.

174. Upon information and belief, the Honda Count VIII Automobiles, or systems therein such as the Mobile Hotspot System or HondaLink® perform or can perform each and every limitation of at least claim 1 of the '138 Patent.

175. Upon information and belief, the Honda Count VIII Automobiles include Qualcomm's 4G LTE modem, which includes Snapdragon Automotive platform, to support Honda's Mobile Hotspot System and HondaLink®. Upon information and belief, the Honda Count VIII Automobiles' Mobile Hotspot System and HondaLink® provide a system that allows several devices to be connected to, for example, the Mobile Hotspot System via Snapdragon Automotive 4G Platform.¹³

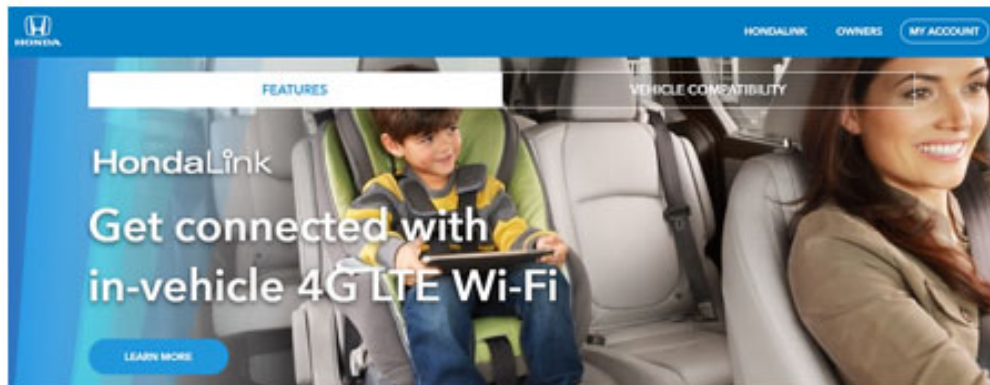

See <https://hondalink.honda.com/#/>.

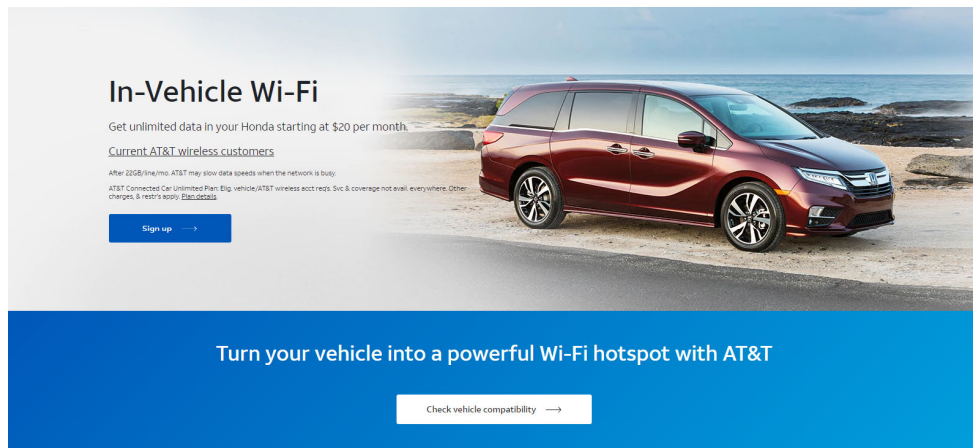

<https://www.att.com/plans/connected-car/honda/>

¹³ See, e.g., <https://hondalink.honda.com/#/>; <https://automobiles.honda.com/accord-sedan/>; <https://automobiles.honda.com/odyssey/>; <https://automobiles.honda.com/insight/>; <https://automobiles.honda.com/pilot#/>; <https://www.qualcomm.com/media/documents/files/qualcomm-ces-press-conference.pdf>.

Touring 2.0T includes the following features and more:

- Low-Speed Braking Control*
- Ventilated Front Seats
- Heated Outboard Rear Seats
- Head-Up Display (HUD)
- Adaptive Damper System
- Wireless Phone Charger*
- Wi-Fi Hotspot Capability*
- Honda Satellite-Linked Navigation System™*
- Rain-Sensing Windshield Wipers
- LED Headlights with Auto-On/Off
- Interior Ambient Lighting
- Body-Colored Parking Sensors (Front/Rear)
- Side Mirrors with Reverse Gear Tilt-Down
- HondaLink® Subscription Services*

<https://automobiles.honda.com/accord-sedan/specs-feature-modals/touring-features>



See <https://www.qualcomm.com/media/documents/files/qualcomm-ces-press-conference.pdf>.

176. Upon information and belief, the Honda Count VIII Automobiles' Mobile Hotspot, HondaLink®, and/or 4G LTE modem are compliant with and use the 3GPP standards.

177. Upon information and belief, the Honda Count VIII Automobiles' Mobile Hotspot, HondaLink®, and/or 4G LTE modem comprise a processor communicatively coupled to a transmitter and circuitry configured to receive. Upon information and belief, the Honda Count VIII Automobiles' Mobile Hotspot, HondaLink®, and/or 4G LTE modem comprise a processor which is communicatively coupled to a transmitter and circuitry configured to receive.

3.2 Abbreviations

UE User Equipment

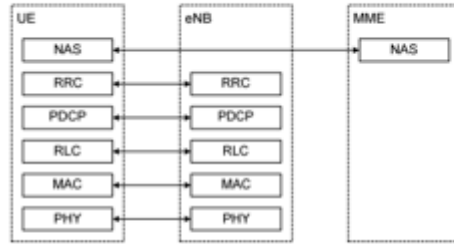

Figure 4.3.2-1: Control-plane protocol stack

7.2 RRC protocol states & state transitions

- At PDCP/RLC/MAC level:
 - UE can transmit and/or receive data to/from network;
 - UE monitors control signalling channel for shared data channel to see if any transmission over the shared data channel has been allocated to the UE;

See Exhibit 13, 3GPP TS 36.300 V8.12.0 at pp. 12, 15, 19, 37, 38.

178. Upon information and belief, the Honda Count VIII Automobiles’ Mobile Hotspot, HondaLink®, and/or 4G LTE modem comprise a processor further configured to cause the circuitry to receive parameters associated with a plurality of radio bearers.

4.3.2 Control plane

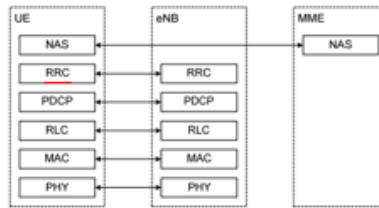

Figure 4.3.2-1: Control-plane protocol stack

See Exhibit 13, 3GPP TS 36.300 V8.12.0 at p. 19.

5.4.3 Multiplexing and assembly

5.4.3.1 Logical channel prioritization

The Logical Channel Prioritization procedure is applied when a new transmission is performed.

RRC controls the scheduling of uplink data by signalling for each logical channel: *priority* where an increasing *priority* value indicates a lower priority level, *prioritisedBitRate* which sets the Prioritized Bit Rate (PBR), *bucketSizeDuration* which sets the Bucket Size Duration (BSD).

See Exhibit 15, 3GPP TS 36.321 V8.12.0 at p. 24.

6.3.2 Radio resource control information elements

LogicalChannelConfig information element

```
-- ASN1START
LogicalChannelConfig ::=
    ul-SpecificParameters
    priority
    prioritisedBitRate
    bucketSizeDuration
SEQUENCE {
    SEQUENCE {
        INTEGER (1..16),
        ENUMERATED {
            kbps0, kbps8, kbps16, kbps32, kbps64, kbps128,
            kbps256, infinity, spare8, spare7, spare6,
            spare5, spare4, spare3, spare2, spare1},
        ENUMERATED {
            ms50, ms100, ms150, ms300, ms500, ms1000, spare2,
            spare1},
    }
}
```

See Exhibit 14, 3GPP TS 36.331 V8.21.0 at pp. 116, 118.

179. Upon information and belief, the Honda Count VIII Automobiles' Mobile Hotspot, HondaLink®, and/or 4G LTE modem comprise a processor configured to further determine a plurality of buffer occupancies, wherein each of the plurality of buffer occupancies is associated with one or more radio bearers of the plurality of radio bearers.

5.4.5 Buffer Status Reporting

The Buffer Status reporting procedure is used to provide the serving eNB with information about the amount of data available for transmission in the UL buffers of the UE. RRC controls BSR reporting by configuring the two timers *periodicBSR-Timer* and *retxBSR-Timer* and by, for each logical channel, optionally signalling *logicalChannelGroup* which allocates the logical channel to an LCG [8].

For the Buffer Status reporting procedure, the UE shall consider all radio bearers which are not suspended and may consider radio bearers which are suspended.

See Exhibit 15, 3GPP TS 36.321 V8.12.0 at Sec. 5.4.5 at p. 25.

6 Layer 2

- The multiplexing of several logical channels (i.e. radio bearers) on the same transport channel (i.e. transport block) is performed by the MAC sublayer;

See Exhibit 13, 3GPP TS 36.300 V8.12.0 at Fig. 6-2 at pp. 31, 32.

180. Upon information and belief, the Honda Count VIII Automobiles' Mobile Hotspot, HondaLink®, and/or 4G LTE modem comprise a processor configured to further cause the transmitter to transmit a message including the plurality of buffer occupancies to a network.

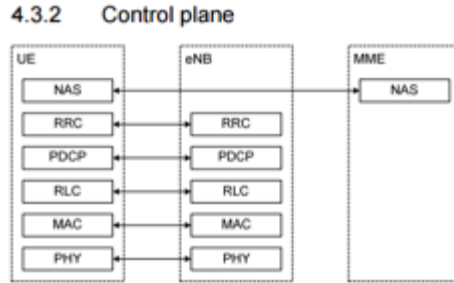

Figure 4.3.2-1: Control-plane protocol stack

See Exhibit 13, 3GPP TS 36.300 V8.12.0 at pp. 18, 19.

5.4.5 Buffer Status Reporting

The Buffer Status reporting procedure is used to provide the serving eNB with information about the amount of data available for transmission in the UL buffers of the UE. RRC controls BSR reporting by configuring the two timers *periodicBSR-Timer* and *retxBSR-Timer* and by, for each logical channel, optionally signalling *logicalChannelGroup* which allocates the logical channel to an LCG [8].

For the Buffer Status reporting procedure, the UE shall consider all radio bearers which are not suspended and may consider radio bearers which are suspended.

A Buffer Status Report (BSR) shall be triggered if any of the following events occur:

See 3GPP TS 36.321 V8.12.0, pp. 25.

181. Upon information and belief, the Honda Count VIII Automobiles' Mobile Hotspot, HondaLink®, and/or 4G LTE modem comprise a processor configured to further cause the circuitry to receive a single allocation of uplink resources.

11.1 Basic Scheduler Operation

MAC in eNB includes dynamic resource schedulers that allocate physical layer resources for the DL-SCH and UL-SCH transport channels. Different schedulers operate for the DL-SCH and UL-SCH.

11.1.2 Uplink Scheduling

In the uplink, E-UTRAN can dynamically allocate resources (PRBs and MCS) to UEs at each TTI via the C-RNTI on PDCCH(s). A UE always monitors the PDCCH(s) in order to find possible allocation for uplink transmission when its downlink reception is enabled (activity governed by DRX when configured). When CA is configured, the same C-RNTI applies to all serving cells.

Physical downlink control channel (PDCCH)

- Informs the UE about the resource allocation of PCH and DL-SCH, and Hybrid ARQ information related to DL-SCH;
- Carries the uplink scheduling grant.

See Exhibit 13, 3GPP TS 36.300 V8.12.0 at pp. 67, 24.

182. Upon information and belief, the Honda Count VIII Automobiles' Mobile Hotspot, HondaLink®, and/or 4G LTE modem comprise a processor configured to further select data from

the plurality of radio bearers for transmission using the single allocation of uplink resources. Upon information and belief, the Honda Count VIII Automobiles' Mobile Hotspot, HondaLink®, and/or 4G LTE modem comprise a processor that selects the data for transmission and allocates resources for each logical channel (i.e. radio bearer) for transmission on the allocated uplink resources. Upon information and belief, in the Honda Count VIII Automobiles' Mobile Hotspot, HondaLink®, and/or 4G LTE modem, the selection of the data occurs using a first iteration and a second iteration. Upon information and belief, in the Honda Count VIII Automobiles' Mobile Hotspot, HondaLink®, and/or 4G LTE modem, in the first iteration, the selection of the data is selected from a subset of the plurality of radio bearers based on the received parameters. Upon information and belief, in the Honda Count VIII Automobiles' Mobile Hotspot, HondaLink®, and/or 4G LTE modem, in the second iteration, the selection of the data is based on buffered data for respective radio bearers.

4.2.1 MAC Entities

E-UTRA defines two MAC entities; one in the UE and one in the E-UTRAN. These MAC entities handle the following transport channels:

- Uplink Shared Channel (UL-SCH);
- Random Access Channel(s) (RACH).

See Exhibit 15, 3GPP TS 36.321 V8.12.0 at p. 8.

5.4.3.1 Logical channel prioritization

The Logical Channel Prioritization procedure is applied when a new transmission is performed.

RRC controls the scheduling of uplink data by signalling for each logical channel: *priority* where an increasing *priority* value indicates a lower priority level, *prioritisedBitRate* which sets the Prioritized Bit Rate (PBR), *bucketSizeDuration* which sets the Bucket Size Duration (BSD).

The UE shall maintain a variable B_j for each logical channel j . B_j shall be initialized to zero when the related logical channel is established, and incremented by the product $PBR \times TTI$ duration for each TTI, where PBR is Prioritized Bit Rate of logical channel j . However, the value of B_j can never exceed the bucket size and if the value of B_j is larger than the bucket size of logical channel j , it shall be set to the bucket size. The bucket size of a logical channel is equal to $PBR \times BSD$, where PBR and BSD are configured by upper layers.

The UE shall perform the following Logical Channel Prioritization procedure when a new transmission is performed:

- The UE shall allocate resources to the logical channels in the following steps:
 - Step 1: All the logical channels with $B_j > 0$ are allocated resources in a decreasing priority order. If the PBR of a radio bearer is set to “infinity”, the UE shall allocate resources for all the data that is available for transmission on the radio bearer before meeting the PBR of the lower priority radio bearer(s);
 - Step 2: the UE shall decrement B_j by the total size of MAC SDUs served to logical channel j in Step 1

NOTE: The value of B_j can be negative.

- Step 3: if any resources remain, all the logical channels are served in a strict decreasing priority order (regardless of the value of B_j) until either the data for that logical channel or the UL grant is exhausted, whichever comes first. Logical channels configured with equal priority should be served equally.

See Exhibit 15, 3GPP TS 36.321 V8.12.0 at p. 24.

183. Upon information and belief, the Honda Count VIII Automobiles’ Mobile Hotspot, HondaLink®, and/or 4G LTE modem comprise a processor configured to further cause the transmitter to transmit a signal including the selected data.

13.1 Bearer service architecture

- A data radio bearer transports the packets of an EPS bearer between a UE and an eNB. When a data radio bearer exists, there is a one-to-one mapping between this data radio bearer and the EPS bearer/E-RAB.

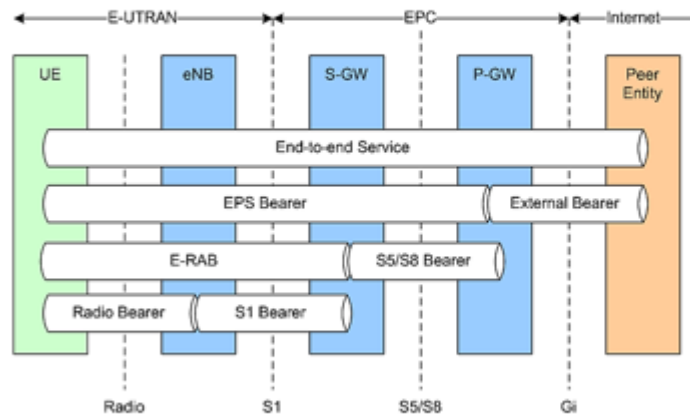

Figure 13.1-1: EPS Bearer Service Architecture

See Exhibit 13, 3GPP TS 36.300 V8.12.0 at p. 71.

184. Accordingly, Honda is using, offering for sale, or selling in the United States the Honda Count VIII Automobiles equipped with a Mobile Hotspot System, HondaLink®, and/or 4G LTE modem that directly infringe one or more claims of the '138 Patent.

185. Additionally, Honda has been, and currently is, actively inducing infringement of the '138 Patent under 35 U.S.C. § 271(b) and contributorily infringing the '138 Patent under 35 U.S.C. § 271(c) either literally and/or by the doctrine of equivalents.

186. Honda knew of the '138 Patent, or should have known of the '138 Patent, but was willfully blind to its existence. Honda has had actual knowledge of the '138 Patent since not later than receipt of a letter dated October 18, 2021 and received on the same date. By the time of trial, Honda will have known and intended (since receiving such notice) that its continued actions would infringe and actively induce and contribute to the infringement of one or more claims of the '138 Patent.

187. Honda has committed, and continues to commit, affirmative acts that cause infringement of one or more claims of the '138 Patent with knowledge of the '138 Patent and knowledge or willful blindness that the induced acts constitute infringement of one or more claims of the '138 Patent. As an illustrative example only, Honda induces such acts of infringement by their affirmative action of providing, promoting, and instructing its customers on how to use Honda's Mobile Hotspot systems, HondaLink® and connectivity features in the Honda Count VIII Automobiles that when used in their normal and customary way as intended and designed by Honda, infringe one or more claims of the '138 Patent.

188. Honda has also committed, and continues to commit, contributory infringement, by *inter alia*, knowingly selling products and/or methods or services that when used cause the direct infringement of one or more claims of the '138 Patent by a third party, and which have no

substantial non-infringing uses, or include a separate and distinct component that is especially made or especially adapted for use in infringement of the '138 Patent and is not a staple article or commodity of commerce suitable for a substantial non-infringing use.

189. As a result of Honda's acts of infringement, Plaintiffs have suffered and will continue to suffer damages in an amount to be proven at trial.

COUNT IX

(Honda's Infringement of U.S. Patent No. 7,684,318)

190. Paragraphs 1-189 are incorporated by reference as if fully set forth herein.

191. Honda has directly infringed, and continues to directly infringe, literally and/or by the doctrine of equivalents, individually and/or jointly, the '318 Patent, by making, using, testing, selling, offering for sale and/or importing into the United States vehicles that embody products and/or services that infringe the '318 Patent including, but are not limited to, products that use the In-Vehicle Wi-Fi, including, but not limited to, the following Honda and Acura Models: Pilot, Odyssey, Passport, Insight, Accord, Civic Sedan, CR-V, Clarity, Fit, HR-V, Ridgeline, RDX, TLX, NLX, and MDX (collectively, "Honda Count IX Automobiles").

192. An exemplary claim, claim 1 of the '318 Patent is reproduced below:

1. A method, comprising:

queuing data frames to be transmitted during a transmitting station's transmit opportunity, wherein the data frames are queued in a queue, wherein the transmit opportunity corresponds to a length of time during which the transmitting station will transmit data frames from the queue to a shared-communications channel, and wherein the transmit opportunity is commenced with a control frame; and

setting a length of time for the transmit opportunity based on a priority of the queue.

193. Upon information and belief, Honda and the Honda Count IX Automobiles perform

or can perform each and every limitation of at least claim 1 of the '318 Patent.

194. Upon information and belief, the Honda Count IX Automobiles are equipped to provide wireless connectivity utilizing IEEE 802.11-2016.

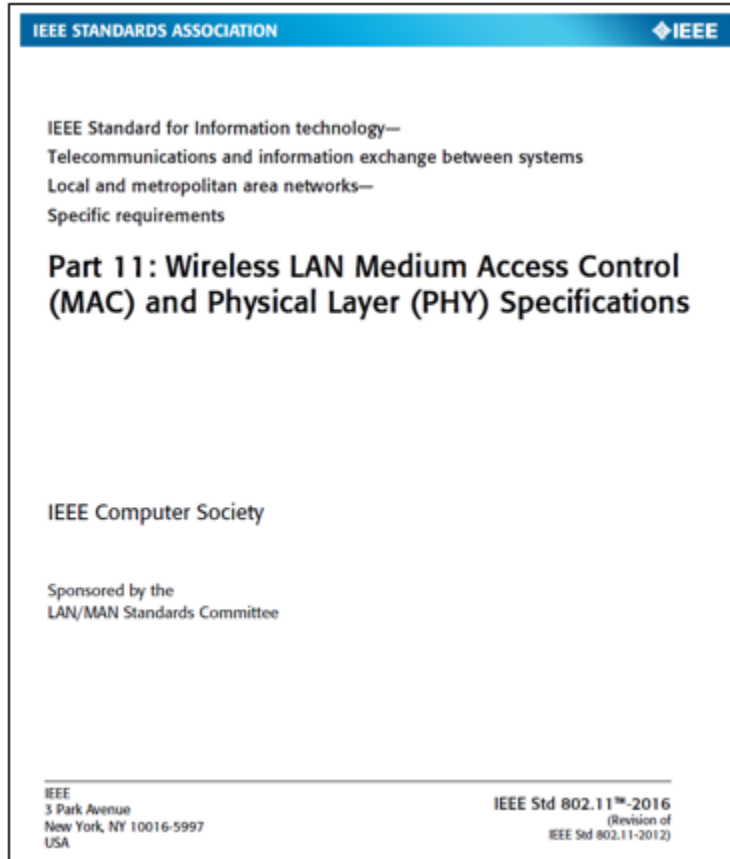

See Exhibit 16, IEEE 802.11-2016.

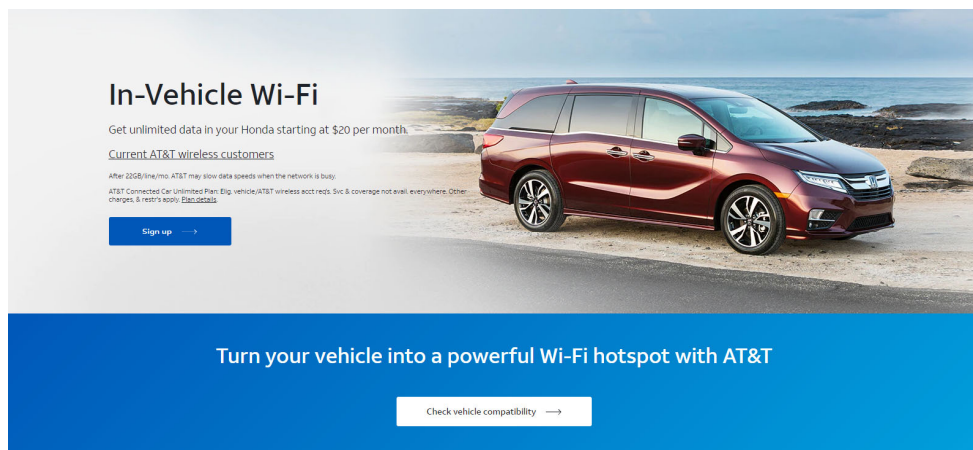

<https://www.att.com/plans/connected-car/honda/>

195. Upon information and belief, the Honda Wi-Fi functionality supports Quality of Service (QoS) capability via the 802.11 standard (“802.11 Wi-Fi”). Upon information and belief, IEEE 802.11-1016 standard defines the Enhanced Distributed Channel Access (EDCA) mechanism for prioritized QoS. This provides access categories (ACs) for differentiating traffic types that have a separate queue for queuing frames to be transferred.

196. Upon information and belief, 802.11 Wi-Fi performs queuing data frames to be transmitted during a transmitting station’s transmit opportunity, wherein the data frames are queued in a queue.

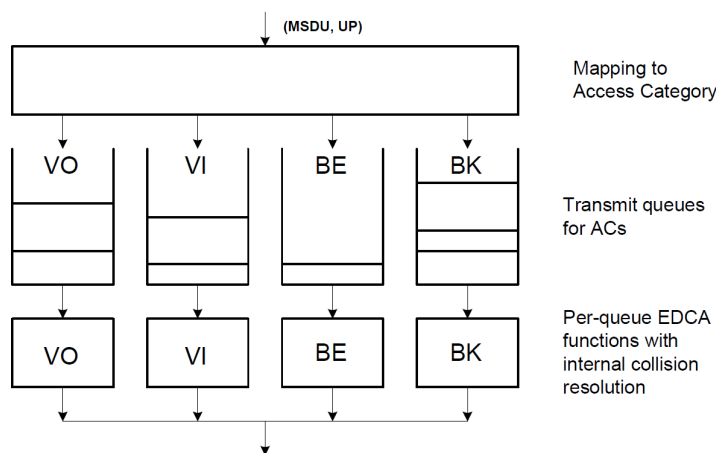

Figure 10-24—Reference implementation model when `dot11AlternateEDCAActivated` is false or not present

See Exhibit 16, IEEE Std 802.11-2016 at p. 1378.

197. Upon information and belief, 802.11 Wi-Fi performs wherein the transmit opportunity corresponds to a length of time during which the transmitting station will transmit data frames from the queue to a shared-communications channel, and wherein the transmit opportunity is commenced with a control frame. Upon information and belief, in an EDCA transmission opportunity or TXOP (transmit opportunity), the transmitting station selects frames for transmission from a set of transmission queues. Upon information and belief, TXOP commences with a control frame.

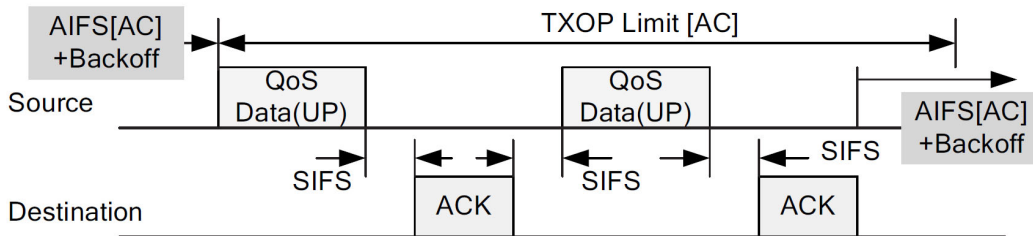

Figure 3.5 EDCA TXOP operation timing structure.

Exhibit 17, Shorey, Rajeev, et al., eds. Mobile, wireless, and sensor networks: technology, applications, and future directions. John Wiley & Sons, 2006, p. 54.

198. Upon information and belief, 802.11 Wi-Fi performs setting a length of time for the transmit opportunity based on a priority of the queue.

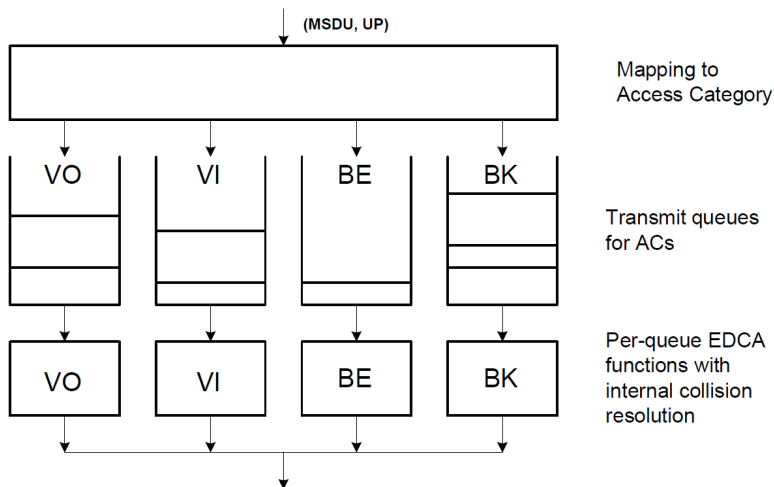

Figure 10-24—Reference implementation model when dot11AlternateEDCAActivated is false or not present

See Exhibit 16, IEEE Std 802.11-2016 at p. 1378.

Table 10-1—UP-to-AC mappings

Priority	UP (Same as IEEE 802.1D user priority)	IEEE 802.1D designation	AC	Transmit queue (dot11Alternate- EDCAActivated false or not present)	Transmit queue (dot11Alternate EDCAActivated true)	Designation (informative)
Lowest ↓ Highest	1	BK	AC_BK	BK	BK	Background
	2	—	AC_BK	BK	BK	Background
	0	BE	AC_BE	BE	BE	Best Effort
	3	EE	AC_BE	BE	BE	Best Effort
	4	CL	AC_VI	VI	A_VI	Video (alternate)
	5	VI	AC_VI	VI	VI	Video (primary)
	6	VO	AC_VO	VO	VO	Voice (primary)
	7	NC	AC_VO	VO	A_VO	Voice (alternate)

See Exhibit 16, IEEE Std 802.11-2016 at pp. 1298-1299.

199. Upon information and belief, Internet connectivity is provided in Honda Count IX Automobiles through as a free trial or through a subscription service through AT&T and/or other Internet providers.

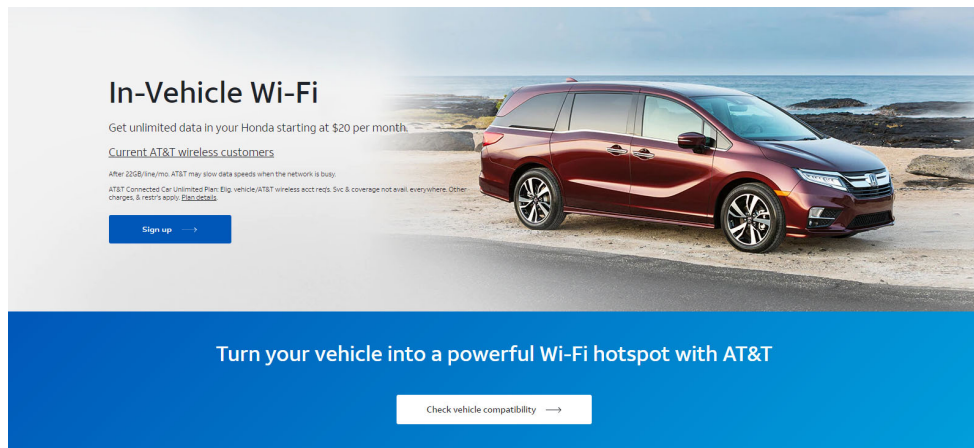

<https://www.att.com/plans/connected-car/honda/>

200. Accordingly, Honda is making, using, testing, selling, offering for sale and/or importing in the United States the Honda Count IX Automobiles that infringe one or more claims of the '318 Patent.

201. Additionally, Honda has been, and currently is, actively inducing infringement of the '318 Patent under 35 U.S.C. § 271(b) and contributorily infringing the '318 Patent under 35 U.S.C. § 271(c) either literally and/or by the doctrine of equivalents.

202. Honda knew of the '318 Patent, or should have known of the '318 Patent, but was willfully blind to its existence. Honda has had actual knowledge of the '318 Patent since not later than receipt of a letter dated October 18, 2021 and received on the same date. By the time of trial, Honda will have known and intended (since receiving such notice) that its continued actions would infringe and actively induce and contribute to the infringement of one or more claims of the '318 Patent.

203. Honda has committed, and continues to commit, affirmative acts that cause infringement of one or more claims of the '318 Patent with knowledge of the '318 Patent and knowledge or willful blindness that the induced acts constitute infringement of one or more claims of the '318 Patent. As an illustrative example only, Honda induces such acts of infringement by its affirmative action of providing, promoting, and instructing its customers on how to use wireless connectivity features in the Honda Count IX Automobiles that when used in their normal and customary way as intended and designed by Honda, infringe one or more claims of the '318 Patent.

204. Honda has also committed, and continues to commit, contributory infringement by, *inter alia*, knowingly selling products and/or methods or services that when used cause the direct infringement of one or more claims of the '318 Patent by a third party, and which have no substantial non-infringing uses, or include a separate and distinct component that is especially made or especially adapted for use in infringement of the '318 Patent and is not a staple article or commodity of commerce suitable for a substantial non-infringing use.

205. As a result of Honda's acts of infringement, Plaintiffs have suffered and will

continue to suffer damages in an amount to be proven at trial.

COUNT X

(Honda's Infringement of U.S. Patent No. 8,953,641)

206. Paragraphs 1-205 are incorporated by reference as if fully set forth herein.

207. Honda has directly infringed, and continues to directly infringe, literally and/or by the doctrine of equivalents, individually and/or jointly, the '641 Patent, by making, using, testing, selling, offering for sale and/or importing into the United States vehicles that embody products and/or services that infringe the '641 Patent including, but not limited to, the Honda Accord, Honda Odyssey, Honda Pilot, Honda Passport and Honda Insight that include a Mobile Hotspot System and HondaLink® (collectively, "Honda Count X Automobiles").¹⁴

208. As an exemplary claim, Claim 11 of the '641 Patent, is reproduced below:

11. A mobile station, comprising:

circuitry configured to receive broadcast information to access an orthogonal frequency division multiple access (OFDMA) system, wherein the broadcast information is received only in a first band having a first bandwidth and the broadcast information is carried by a plurality of groups of subcarriers with each group having a plurality of contiguous subcarriers; and

circuitry configured to determine a second bandwidth of a second band that is associated with the OFDMA system based upon the broadcast information received in the first band, wherein a second bandwidth of the second band is greater

¹⁴ See, e.g., <https://hondalink.honda.com/#/compatibility?year=2018&model=Odyssey>; <https://www.hondaoflincoln.com/2018-honda-odyssey-first-minivan-with-4g-lte-in-vehicle-wi-fi-offering-customers-unlimited-data-from-att>; <https://hondalink.honda.com/#/compatibility?year=2019&model=Passport>; <https://hondalink.honda.com/#/compatibility?year=2019&model=Pilot>.

than the first bandwidth of the first band,

wherein the first band is contained within the second band,

wherein a data channel is carried by at least one subcarrier group of the second band,

wherein the plurality of contiguous subcarriers have fixed spacing,

wherein a number of usable subcarriers is adjustable to realize a variable band, wherein the number of usable subcarriers is determined based on a plurality of operating channel bandwidths, and

wherein the first band is defined as a frequency segment with a bandwidth that is not greater than a smallest operating channel bandwidth among the plurality of operating channel bandwidths, the first band having a same value for the plurality of operating channel bandwidths wherein the mobile station is configured to operate within the plurality of operating channel bandwidths.

209. Upon information and belief, the Honda Count X Automobiles include Qualcomm's 4G LTE modem that includes a Snapdragon Automotive platform to support Honda's Mobile Hotspot System and HondaLink®. Upon information and belief, the Honda Count X Automobiles' Mobile Hotspot System and HondaLink® provide a system wherein a user can connect with 4G LTE to the Internet.¹⁵

¹⁵ <https://www.prnewswire.com/news-releases/att-and-american-honda-enter-connected-car-agreement-300385547.html>

In-Vehicle Wi-Fi

Get unlimited data in your Honda starting at \$20 per month.

Current AT&T wireless customers

After 22GB/line/mo. AT&T may slow data speeds when the network is busy.
AT&T Connected Car Unlimited Plan (Eq. vehicle)/AT&T wireless acct reqs. Svc. & coverage not avail. everywhere. Other charges & restrictions apply. ©2018 AT&T

Sign up →

Turn your vehicle into a powerful Wi-Fi hotspot with AT&T

Check vehicle compatibility →

<https://www.att.com/plans/connected-car/honda/>

Touring 2.0T includes the following features and more:

- Low-Speed Braking Control*
- Ventilated Front Seats
- Heated Outboard Rear Seats
- Head-Up Display (HUD)
- Adaptive Damper System
- Wireless Phone Charger*
- Wi-Fi Hotspot Capability*
- Honda Satellite-Linked Navigation System™*
- Rain-Sensing Windshield Wipers
- LED Headlights with Auto-On/Off
- Interior Ambient Lighting
- Body-Colored Parking Sensors (Front/Rear)
- Side Mirrors with Reverse Gear Tilt-Down
- HondaLink® Subscription Services*

<https://automobiles.honda.com/accord-sedan/specs-feature-modals/touring-features>

Qualcomm Technologies, Inc. (QTI), a subsidiary of Qualcomm Incorporated (NASDAQ: QCOM), announced today its continued support for cutting-edge personalization, infotainment and telematics systems, as demonstrated with the recent launch of the 2018 Honda Accord. The 2018 Honda Accord features a highly advanced Snapdragon Automotive Platform to power cutting-edge applications for its in-vehicle infotainment and navigation system. Snapdragon automotive solutions are designed to support automotive manufactures' efforts to provide rich, intuitive experiences to consumers. As part of Qualcomm Technologies' efforts to offer widespread support for automotive manufactures implementations of the connected car the 2018 Honda Accord also features a Qualcomm® 4G LTE modem which is designed to support the Hondalink™ vehicle connectivity system.

<https://www.qualcomm.com/news/releases/2018/01/08/qualcomm-powers-advanced-connected-car-technologies-2018-honda-accord>

210. Upon information and belief, the Honda Count X Automobiles' Mobile Hotspot, HondaLink®, and/or 4G LTE modem are compliant with and use the 3GPP standards.

211. Upon information and belief, the Honda Count X Automobiles include circuitry configured to receive broadcast information to access an orthogonal frequency division multiple access (OFDMA) system.¹⁶

4.3.2 Control plane

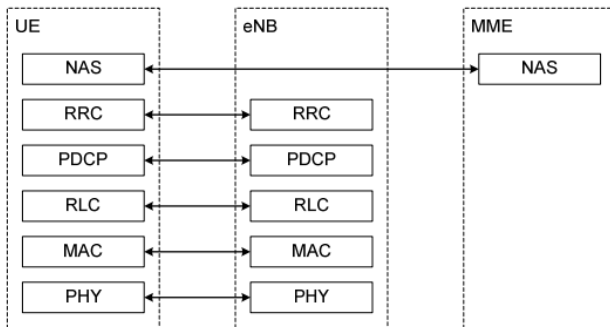

Figure 4.3.2-1: Control-plane protocol stack

4 Overall architecture

The E-UTRAN consists of eNBs, providing the E-UTRA user plane (PDCP/RLC/MAC/PHY) and control plane (RRC) protocol terminations towards the UE. The eNBs are interconnected with each other by means of the X2 interface. The eNBs are also connected by means of the S1 interface to the EPC (Evolved Packet Core), more specifically to the MME (Mobility Management Entity) by means of the S1-MME and to the Serving Gateway (S-GW) by means of the S1-U. The S1 interface supports a many-to-many relation between MMEs / Serving Gateways and eNBs.

4.3.2 Control plane

- RRC (terminated in eNB on the network side) performs the functions listed in subclause 7, e.g.:
 - Broadcast;

5.1 Downlink Transmission Scheme

5.1.1 Basic transmission scheme based on OFDM

The downlink transmission scheme is based on conventional OFDM using a cyclic prefix. The OFDM sub-carrier spacing is $\Delta f = 15$ kHz. 12 consecutive sub-carriers during one slot correspond to one downlink *resource block*. In the frequency domain, the number of resource blocks, N_{RB} , can range from $N_{RB-min} = 6$ to $N_{RB-max} = 110$.

See Exhibit 13, 3GPP TS 36.300 at pp. 18, 19, 15, 25.

212. Upon information and belief, broadcast information is received only in a first band having a first bandwidth.¹⁷

¹⁶ Exhibit 13, 3GPP TS 36.300 at pp. 18, 19, 15, 25.

¹⁷ See Exhibit 18, 3GPP TS 36.211 V8.9.0 at Sec. 6.6.4, pp. 56, 57, 8.

6.6 Physical broadcast channel

6.6.4 Mapping to resource elements

The block of complex-valued symbols $y^{(p)}(0), \dots, y^{(p)}(M_{\text{sybm}} - 1)$ for each antenna port is transmitted during 4 consecutive radio frames starting in each radio frame fulfilling $n_f \bmod 4 = 0$ and shall be mapped in sequence starting with $y(0)$ to resource elements (k, l) . The mapping to resource elements (k, l) not reserved for transmission of reference signals shall be in increasing order of first the index k , then the index l in slot 1 in subframe 0 and finally the radio frame number. The resource-element indices are given by

$$k = \frac{N_{\text{RB}}^{\text{DL}} N_{\text{sc}}^{\text{RB}}}{2} - 36 + k', \quad k' = 0, 1, \dots, 71$$

$$l = 0, 1, \dots, 3$$

where resource elements reserved for reference signals shall be excluded. The mapping operation shall assume cell-specific reference signals for antenna ports 0-3 being present irrespective of the actual configuration. The UE shall assume that the resource elements assumed to be reserved for reference signals in the mapping operation above but not used for transmission of reference signal are not available for PDSCH transmission. The UE shall not make any other assumptions about these resource elements.

See Exhibit 18, 3GPP TS 36.211 V8.9.0 at Sec. 6.6.4, pp. 56, 57.

213. Upon information and belief, broadcast information is received only in a first band having a first bandwidth and the broadcast information is carried by a plurality of groups of subcarriers with each group having a plurality of contiguous subcarriers.¹⁸

5.1.1 Basic transmission scheme based on OFDM

The downlink transmission scheme is based on conventional OFDM using a cyclic prefix. The OFDM sub-carrier spacing is $\Delta f = 15$ kHz. 12 consecutive sub-carriers during one slot correspond to one downlink *resource block*. In the frequency domain, the number of resource blocks, N_{RB} , can range from $N_{\text{RB-min}} = 6$ to $N_{\text{RB-max}} = 110$.

See Exhibit 13, 3GPP TS 36.300 V8.12.0 at p. 25.

214. Upon information and belief, the Honda Count X Automobiles include circuitry configured to determine a second bandwidth of a second band that is associated with the OFDMA system based upon the broadcast information received in the first band.¹⁹

¹⁸ See Exhibit 13, 3GPP TS 36.300 V8.12.0 at p. 25; Exhibit 14, 3GPP TS 36.331 V8.21.0 at p. 21.

¹⁹ See Exhibit 14, 3GPP TS 36.331 V8.21.0 at pp. 21, 85 and 86.

Physical broadcast channel (PBCH)

- The coded BCH transport block is mapped to four subframes within a 40 ms interval;
- 40 ms timing is blindly detected, i.e. there is no explicit signalling indicating 40 ms timing;
- Each subframe is assumed to be self-decodable, i.e. the BCH can be decoded from a single reception, assuming sufficiently good channel conditions.

See Exhibit 13, 3GPP TS 36.300 V8.12.0 at p. 24.

215. Upon information and belief, the second bandwidth of the second band is greater than the first bandwidth of the first band.

Table 5.6-1 Transmission bandwidth configuration N_{RB} in E-UTRA channel bandwidths

Channel bandwidth $BW_{Channel}$ [MHz]	1.4	3	5	10	15	20
Transmission bandwidth configuration N_{RB}	6	15	25	50	75	100

See Exhibit 19, 3GPP TS 36.104 V8.14.1 at p. 14.

216. Upon information and belief, the Honda Count X Automobiles include a mobile station wherein the first band is contained within the second band and wherein a data channel is carried by at least one subcarrier group of the second band.

217. Upon information and belief, the Honda Count X Automobiles include a mobile station wherein the plurality of contiguous subcarriers have fixed spacing.²⁰

5.1.1 Basic transmission scheme based on OFDM

The downlink transmission scheme is based on conventional OFDM using a cyclic prefix. The OFDM sub-carrier spacing is $\Delta f = 15$ kHz. 12 consecutive sub-carriers during one slot correspond to one downlink *resource block*. In the frequency domain, the number of resource blocks, N_{RB} , can range from $N_{RB-min} = 6$ to $N_{RB-max} = 110$.

See Exhibit 13, 3GPP TS 36.300 V8.12.0 at p. 25.

218. Upon information and belief, the Honda Count X Automobiles include a mobile station wherein a number of usable subcarriers is adjustable to realize a variable band, wherein the number of usable subcarriers is determined based on a plurality of operating channel

²⁰ Exhibit 13, 3GPP TS 36.300 V8.12.0 at p. 25.

bandwidths.²¹

5.1.1 Basic transmission scheme based on OFDM

The downlink transmission scheme is based on conventional OFDM using a cyclic prefix. The OFDM sub-carrier spacing is $\Delta f = 15$ kHz. 12 consecutive sub-carriers during one slot correspond to one downlink *resource block*. In the frequency domain, the number of resource blocks, N_{RB} , can range from $N_{RB-min} = 6$ to $N_{RB-max} = 110$.

See Exhibit 13, 3GPP TS 36.300 V8.12.0 at p. 25.

219. Upon information and belief, the Honda Count X Automobiles include a mobile station wherein the first band is defined as a frequency segment with a bandwidth that is not greater than a smallest operating channel bandwidth among the plurality of operating channel bandwidths, the first band having a same value for the plurality of operating channel bandwidths.²²

LTE bandwidth	1.4 MHz	3 MHz	5 MHz	10 MHz	15 MHz	20 MHz
PBCH Resource Elements per radio Frame	240	240	240	240	240	240
Overhead(normal CP)	240/ 10080 = 2.4%	240/ 25200 = 1.0%	240/ 42000 = 0.6%	240/ 84000 = 0.3%	240/ 126000 = 0.2%	240/ 168000 = 0.1%
Overhead(extended CP)	240/ 8640 = 2.8%	240/ 21600 = 1.1%	240/ 36000 = 0.7%	240/ 72000 = 0.3%	240/ 108000 = 0.2%	240/ 144000 = 0.2%

220. Upon information and belief, the Honda Count X Automobiles include a mobile station configured to operate within the plurality of operating channel bandwidths.²³

²¹ Exhibit 13, 3GPP TS 36.300 V8.12.0 at p. 25; Exhibit 19, 3GPP TS 36.104 V8.14.1 at p. 14; Exhibit 14, 3GPP TS 36.331 V8.21.0 at pp. 85-86.

²² Exhibit 19, 3GPP TS 36.104 V8.14.1 at p. 14; <http://www.rfwireless-world.com/Terminology/LTE-PBCH-Physical-Broadcast-Channel.html>.

²³ Exhibit 14, 3GPP TS 36.331 V8.21.0 at pp. 85-86; Exhibit 19, 3GPP TS 36.104 V8.14.1 at p. 14; Exhibit 13, 3GPP TS 36.300 V8.12.0 at p. 24.

Physical broadcast channel (PBCH)

- The coded BCH transport block is mapped to four subframes within a 40 ms interval;
- 40 ms timing is blindly detected, i.e. there is no explicit signalling indicating 40 ms timing;
- Each subframe is assumed to be self-decodable, i.e. the BCH can be decoded from a single reception, assuming sufficiently good channel conditions.

See Exhibit 13, 3GPP TS 36.300 V8.12.0 at p. 24.

221. Accordingly, Honda is using, offering for sale, or selling in the United States the Honda Count X Automobiles equipped with a Mobile Hotspot System, HondaLink®, and/or 4G LTE modem that directly infringe one or more claims of the '641 Patent.

222. Additionally, Honda has been, and currently is, actively inducing infringement of the '641 Patent under 35 U.S.C. § 271(b) and contributorily infringing the '641 Patent under 35 U.S.C. § 271(c) either literally and/or by the doctrine of equivalents.

223. Honda knew of the '641 Patent, or should have known of the '641 Patent, but was willfully blind to its existence. Honda has had actual knowledge of the '641 Patent since not later than receipt of a letter dated October 18, 2021 and received on the same date. By the time of trial, Honda will have known and intended (since receiving such notice) that its continued actions would infringe and actively induce and contribute to the infringement of one or more claims of the '641 Patent.

224. Honda has committed, and continues to commit, affirmative acts that cause infringement of one or more claims of the '641 Patent with knowledge of the '641 Patent and knowledge or willful blindness that the induced acts constitute infringement of one or more claims of the '641 Patent. As an illustrative example only, Honda induces such acts of infringement by its affirmative action of providing, promoting, and instructing its customers on how to use Honda's Mobile Hotspot systems, HondaLink® and connectivity features in the Honda Count X Automobiles that when used in their normal and customary way as intended and designed by

Honda, infringe one or more claims of the '641 Patent.

225. Honda has also committed, and continues to commit, contributory infringement, by *inter alia*, knowingly selling products and/or methods or services that when used cause the direct infringement of one or more claims of the '641 Patent by a third party, and which have no substantial non-infringing uses, or include a separate and distinct component that is especially made or especially adapted for use in infringement of the '641 Patent and is not a staple article or commodity of commerce suitable for a substantial non-infringing use.

226. As a result of Honda's acts of infringement, Plaintiffs have suffered and will continue to suffer damages in an amount to be proven at trial.

COUNT XI

(Honda's Infringement of U.S. Patent No. 8,811,356)

227. Paragraphs 1-226 are incorporated by reference as if fully set forth herein.

228. Honda has directly infringed, and continues to directly infringe, literally and/or by the doctrine of equivalents, individually and/or jointly, the '356 Patent, by making, using, testing, selling, offering for sale and/or importing into the United States vehicles that embody products and/or services that infringe the '356 Patent including, but not limited to, the Honda Accord, Honda Pilot, Honda Odyssey, and Honda Insight, that include the Mobile Hotspot System and/or HondaLink® (collectively, "Honda Count XI Automobiles").

229. An exemplary claim, claim 1 of the '356 Patent is reproduced below:

1. A user equipment (UE) comprising:

a processor configured to receive resource allocation information associated with an uplink physical control channel, wherein the uplink physical control channel and a physical uplink shared channel have different resources;

the processor is further configured to send data over the physical uplink shared

channel in assigned time intervals;

the processor is further configured, in a time interval that it is not sending information over the physical uplink shared channel, to send a signal over the uplink physical control channel based on the received resource allocation information; and

the processor is further configured to receive feedback information from a downlink control channel.

230. Upon information and belief, the Honda Count XI Automobiles or systems therein, such as the Mobile Hotspot System or HondaLink®, perform or can perform each and every limitation of at least claim 1 of the '356 Patent.

231. Upon information and belief, Honda Count XI Automobiles include Qualcomm's 4G LTE modem, which includes a Snapdragon Automotive platform, to support Honda's Mobile Hotspot System and HondaLink®. Upon information and belief, the Honda Count XI Automobiles' Mobile Hotspot System and HondaLink® provide a system that allows several devices to be connected to, for example, the Mobile Hotspot System via the Snapdragon Automotive 4G Platform.²⁴

²⁴ See, e.g., <https://hondalink.honda.com/#/>; <https://automobiles.honda.com/accord-sedan>; <https://automobiles.honda.com/odyssey>; <https://automobiles.honda.com/insight>; <https://automobiles.honda.com/pilot#>; <https://www.qualcomm.com/media/documents/files/qualcomm-ces-press-conference.pdf>.

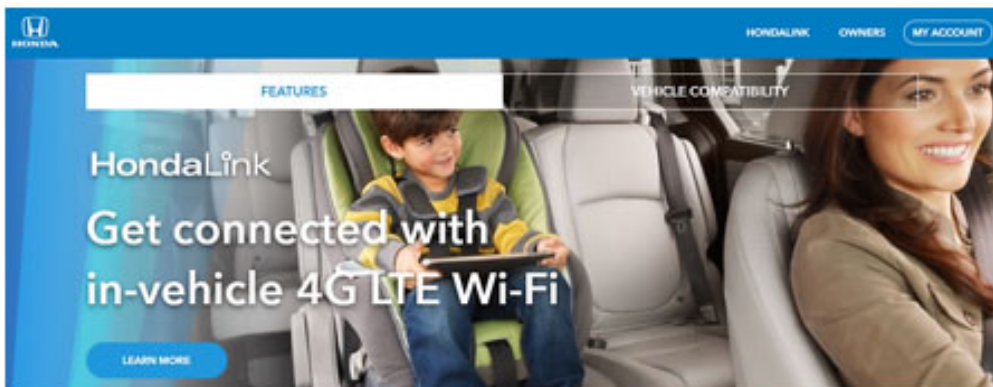

See <https://hondalink.honda.com/#/>.

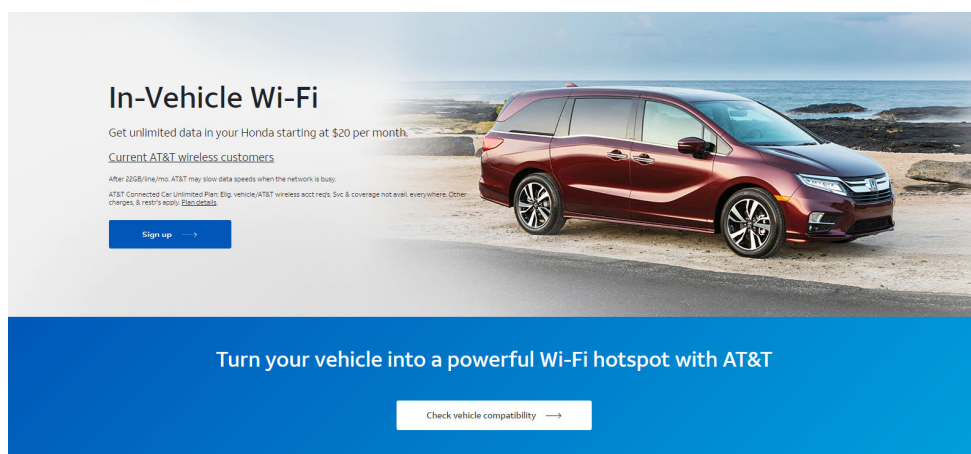

<https://www.att.com/plans/connected-car/honda/>

Touring 2.0T includes the following features and more:

- Low-Speed Braking Control*
- Ventilated Front Seats
- Heated Outboard Rear Seats
- Head-Up Display (HUD)
- Adaptive Damper System
- Wireless Phone Charger*
- Wi-Fi Hotspot Capability*
- Honda Satellite-Linked Navigation System™*
- Rain-Sensing Windshield Wipers
- LED Headlights with Auto-On/Off
- Interior Ambient Lighting
- Body-Colored Parking Sensors (Front/Rear)
- Side Mirrors with Reverse Gear Tilt-Down
- HondaLink® Subscription Services*

<https://automobiles.honda.com/accord-sedan/specs-feature-modals/touring-features>



See, e.g., <https://www.qualcomm.com/media/documents/files/qualcomm-ces-press-conference.pdf>.

232. Upon information and belief, the Honda Count XI Automobiles’ Mobile Hotspot, HondaLink®, and/or 4G LTE modem are compliant with and use the 3GPP standards.

233. Upon information and belief, the Honda Count XI Automobiles using, for example, a 4G LTE modem comprise a processor configured to receive resource allocation information associated with an uplink physical control channel, wherein the uplink physical control channel and a physical uplink shared channel have difference resources. Upon information and belief, the uplink physical control channel and a physical uplink shared channel in the 4G LTE modem used in the Honda Count XI Automobiles are transmitted on different sets of sub-carriers.

5.2.2 System information acquisition

5.2.2.1 General

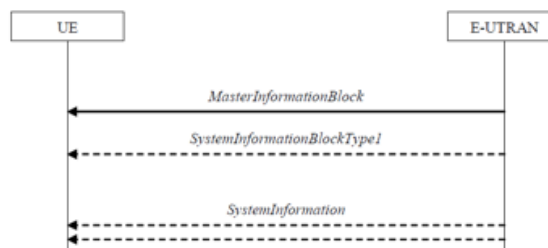

See Exhibit 14, 3GPP TS 36.331 V8.21.0 at p. 23.

5.4 Physical uplink control channel

The physical resources used for PUCCH depends on two parameters, $N_{RB}^{(2)}$ and $N_{cs}^{(1)}$, given by higher layers. The variable $N_{RB}^{(2)} \geq 0$ denotes the bandwidth in terms of resource blocks that are available for use by PUCCH formats 2/2a/2b transmission in each slot. The variable $N_{cs}^{(1)}$ denotes the number of cyclic shift used for PUCCH formats 1/1a/1b in a resource block used for a mix of formats 1/1a/1b and 2/2a/2b. The value of $N_{cs}^{(1)}$ is an integer multiple of Δ_{shift}^{PUCCH} within the range of $\{0, 1, \dots, 7\}$, where Δ_{shift}^{PUCCH} is provided by higher layers. No mixed resource block is

See Exhibit 18, 3GPP TS 36.211 V8.9.0 at p. 16.

6.3.1 System information blocks

SystemInformationBlockType2

The IE *SystemInformationBlockType2* contains radio resource configuration information that is common for all UEs.

6.3.2 Radio resource control information elements

RadioResourceConfigCommon

RadioResourceConfigCommon information element

```
-- ASN1START
RadioResourceConfigCommonSIB ::= SEQUENCE {
    rach-ConfigCommon          RACH-ConfigCommon,
    bccch-Config               BCCH-Config,
    pcch-Config                PCCH-Config,
    prach-Config               PRACH-ConfigSIB,
    pdsch-ConfigCommon         PDSCH-ConfigCommon,
    pusch-ConfigCommon         PUSCH-ConfigCommon,
    pucch-ConfigCommon         PUCCH-ConfigCommon,
```

See Exhibit 14, 3GPP TS 36.331 V8.21.0 at pp. 105, 116, 128.

234. Upon information and belief, the Honda Count XI Automobiles using a 4G LTE modem comprise a processor further configured to send data over the physical uplink shared channel in assigned time intervals.

11.1.2 Uplink Scheduling

In the uplink, E-UTRAN can dynamically allocate resources (PRBs and MCS) to UEs at each TTI via the C-RNTI on PDCCH(s). A UE always monitors the PDCCH(s) in order to find possible allocation for uplink transmission when its downlink reception is enabled (activity governed by DRX when configured).

See Exhibit 13, 3GPP TS 36.300 V8.12.0 at p. 67.

8 Physical uplink shared channel related procedures

For FDD and normal HARQ operation, the UE shall upon detection of a PDCCH with DCI format 0 and/or a PHICH transmission in subframe n intended for the UE, adjust the corresponding PUSCH transmission in subframe $n+4$ according to the PDCCH and PHICH information.

See Exhibit 20, 3GPP TS 36.213 V8.8.0 at p. 52.

5 Physical Layer for E-UTRA

Downlink and uplink transmissions are organized into radio frames with 10 ms duration. Two radio frame structures are supported:

- Type 1, applicable to FDD,
- Type 2, applicable to TDD.

Frame structure Type 1 is illustrated in Figure 5.1-1. Each 10 ms radio frame is divided into ten equally sized sub-frames. Each sub-frame consists of two equally sized slots. For FDD, 10 subframes are available for downlink transmission and 10 subframes are available for uplink transmissions in each 10 ms interval. Uplink and downlink transmissions are separated in the frequency domain.

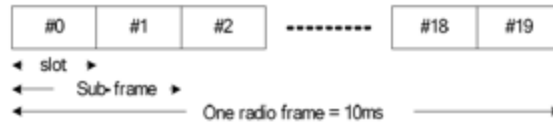

See Exhibit 13, 3GPP TS 36.300 V8.12.0 at p. 23.

235. Upon information and belief, the Honda Count XI Automobiles using, for example, a 4G LTE modem comprise a processor further configured, in a time interval that it is not sending information over the physical uplink shared channel, to send a signal over the uplink physical control channel based on the received resource allocation information.

5.4 Physical uplink control channel

The physical uplink control channel, PUCCH, carries uplink control information. The PUCCH is never transmitted simultaneously with the PUSCH from the same UE. For frame structure type 2, the PUCCH is not transmitted in the UpPTS field.

See Exhibit 18, 3GPP TS 36.211 V8.9.0 at p. 16.

236. Upon information and belief, the Honda Count XI Automobiles using a 4G LTE modem comprise a processor further configured to receive feedback information from a downlink control channel.

5 Physical Layer for E-UTRA

The physical channels of E-UTRA are:

Physical Hybrid ARQ Indicator Channel (PHICH)

- Carries Hybrid ARQ ACK/NAKs in response to uplink transmissions.

See Exhibit 13, 3GPP TS 36.300 V8.12.0 at pp. 23. 24.

4.2 Downlink

Table 4.2-2

Control information	Physical Channel
CFI	PCFICH
HI	PHICH
DCI	PDCCH

See Exhibit 21, 3GPP TS 36.212 V8.8.0 at p. 8.

237. Accordingly, Honda is using, offering for sale, or selling in the United States the Honda Count XI Automobiles equipped with a Mobile Hotspot System, HondaLink®, and/or 4G LTE modem infringe one or more claims of the '356 Patent.

238. Additionally, Honda has been, and currently is, actively inducing infringement of the '356 Patent under 35 U.S.C. § 271(b) and contributorily infringing the '356 Patent under 35 U.S.C. § 271(c) either literally and/or by the doctrine of equivalents.

239. Honda knew of the '356 Patent, or should have known of the '356 Patent, but was willfully blind to its existence. Honda has had actual knowledge of the '356 Patent since not later than receipt of a letter dated October 18, 2021 and received on the same date. By the time of trial, Honda will have known and intended (since receiving such notice) that its continued actions would infringe and actively induce and contribute to the infringement of one or more claims of the '356 Patent.

240. Honda has committed, and continues to commit, affirmative acts that cause infringement of one or more claims of the '356 Patent with knowledge of the '356 Patent and knowledge or willful blindness that the induced acts constitute infringement of one or more claims of the '356 Patent. As an illustrative example only, Honda induces such acts of infringement by its affirmative action of providing, promoting, and instructing its customers on how to use Honda's Mobile Hotspot System, HondaLink® and connectivity features in the Honda Count XI Automobiles that when used in their normal and customary way as intended and designed by

Honda, infringe one or more claims of the '356 Patent.

241. Honda has also committed, and continues to commit, contributory infringement, by *inter alia*, knowingly selling products and/or methods or services that when used cause the direct infringement of one or more claims of the '356 Patent by a third party, and which have no substantial non-infringing uses, or include a separate and distinct component that is especially made or especially adapted for use in infringement of the '356 Patent and is not a staple article or commodity of commerce suitable for a substantial non-infringing use.

242. As a result of Honda's acts of infringement, Plaintiffs have suffered and will continue to suffer damages in an amount to be proven at trial.

DEMAND FOR JURY TRIAL

243. Under Rule 38(b) of the Federal Rules of Civil Procedure, Plaintiffs respectfully request a trial by jury on all issues so triable.

PRAYER FOR RELIEF

WHEREFORE, Plaintiffs respectfully request the following relief:

- A. A judgment that the Patents-in-Suit are valid and enforceable;
- B. A judgment that Defendants directly infringe, contributorily infringe, and/or induce infringement of one or more claims of *each of* the Patents-in-Suit;
- C. A judgment that awards Plaintiffs all damages adequate to compensate them for Defendants' direct infringement, contributory infringement, and/or induced infringement, of the Patents-in-Suit, including all pre-judgment and post-judgment interest at the maximum rate permitted by law;
- D. A judgment that awards Plaintiffs all appropriate damages under 35 U.S.C. § 284 for Defendants' past infringement with respect to the Patents-in-Suit;

- E. A judgment that awards Plaintiffs all appropriate damages under 35 U.S.C. § 284 for Defendants' continuing or future infringement, up until the date such judgment is entered with respect to the Patents-in-Suit, including ongoing royalties, pre- or post-judgment interest, costs, and disbursements as justified under 35 U.S.C. § 284;
- F. A judgment that this case is exceptional under 35 U.S.C. § 285;
- G. An accounting of all damages not presented at trial; and
- H. A judgment that awards Plaintiffs their costs, disbursements, attorneys' fees, and such further and additional relief as is deemed appropriate by the Court.

Dated: October 19, 2021

RESPECTFULLY SUBMITTED,

By: /s/ Jonathan K. Waldrop, with permission by
Allen F. Gardner

Allen F. Gardner (TX Bar No. 24043679)
Allen@allengardnerlaw.com
ALLEN GARDNER LAW, PLLC
609 S. Fannin
Tyler, Texas 75701
Telephone: (903) 944-7537
Facsimile: (903) 944-7856

Jonathan K. Waldrop (CA Bar No. 297903)
(Admitted in this District)
jwaldrop@kasowitz.com
Darcy L. Jones (CA Bar No. 309474)
(Admitted in this District)
djones@kasowitz.com
Marcus A. Barber (CA Bar No. 307361)
(Admitted in this District)
mbarber@kasowitz.com
ThucMinh Nguyen (CA Bar No. 304382)
(Admission pending)
tnguyen@kasowitz.com
John W. Downing (CA Bar No. 252850)
(Admitted in this District)
jdowning@kasowitz.com
Heather S. Kim (CA Bar No. 277686)
(Admitted in this District)
hkim@kasowitz.com
Jack Shaw (CA Bar No. 309382)
(Admitted in this District)
jshaw@kasowitz.com
KASOWITZ BENSON TORRES LLP
333 Twin Dolphin Drive, Suite 200
Redwood Shores, California 94065
Telephone: (650) 453-5170
Facsimile: (650) 453-5171

Attorneys for Plaintiffs
INTELLECTUAL VENTURES I LLC, and
INTELLECTUAL VENTURES II LLC

CERTIFICATE OF SERVICE

The undersigned certifies that a copy of the foregoing document was served on all parties who have appeared in this case on October 19, 2021, via the Court's CM/ECF system.

/s/ Allen F. Gardner

Allen F. Gardner