

**IN THE UNITED STATES DISTRICT COURT  
FOR THE DISTRICT OF MASSACHUSETTS**

NOVOLUTO GMBH,

Plaintiff,

v.

CLIO DESIGNS, INC.,

Defendant.

Civil Action No.: \_\_\_\_\_

**JURY TRIAL DEMANDED**

**COMPLAINT FOR PATENT INFRINGEMENT**

Plaintiff, Novoluto GmbH (“Novoluto” or “Plaintiff”), files this complaint against Defendant, Clio Designs, Inc. (“Clio” or “Defendant”), seeking damages and other relief for Clio’s infringement of U.S. Patent No. 9,763,851. Novoluto, by and through its counsel, alleges and states, with knowledge as to its own acts and on information and belief as to other matters, as follows:

**NATURE OF THE ACTION**

1. This is a patent infringement case arising under the Patent Laws of the United States, 35 U.S.C. § 1, *et seq.*
2. Novoluto owns U.S. Patent No. 9,763,851 (“the ’851 Patent” or “the Asserted Patent”), titled “Stimulation Device” (Exhibit 1), and has the right to enforce this patent against infringers.
3. Clio has directly infringed one or more claims of the Asserted Patent by making, using, selling, offering to sell, and/or importing stimulation devices such as Clio’s “plusOne Air Pulsing Arouser” (the “plusOne Air” or “Accused Product”). This infringement has been willful as Clio knew about Novoluto’s patented products and its patent when Clio intentionally designed the Accused Product to be a less-expensive version of Novoluto’s patented products.

**THE PARTIES**

4. Plaintiff Novoluto is a company organized and existing under the laws of Germany, with a principal place of business at Friedenstraße 91-91a, 10249 Berlin, Germany.

5. Defendant Clio Designs, Inc. is a corporation organized and existing under the laws of Massachusetts, with a principal place of business in Newton, Massachusetts.

**JURISDICTION AND VENUE**

6. This is an action for patent infringement arising under the patent laws of the United States, 35 U.S.C. §§ 1 *et seq.* This Court has subject matter jurisdiction over this action pursuant to at least 28 U.S.C. §§ 1331 and 1338(a).

7. This Court has personal jurisdiction over Defendant because, *inter alia*, it resides in the Commonwealth of Massachusetts, is an entity organized under the laws of the Commonwealth of Massachusetts, has its principal place of business in this District, regularly conducts business in this District, and continues to commit acts of patent infringement in this District, including by making, using, offering to sell, and/or selling products that infringe the Asserted Patent within this District.

8. Venue is proper in the District of Massachusetts pursuant to 28 U.S.C. § 1400(b) because Defendant resides in, has committed and continues to commit acts of patent infringement in, and has its principal place of business in this District.

**BACKGROUND**

9. The '851 Patent duly and legally issued from the United States Patent and Trademark Office (USPTO) to applicant and assignee, Plaintiff Novoluto, on September 19, 2017. The '851 Patent describes the first sexual stimulation device to use modulated positive and negative pressures with respect to a reference pressure to enhance sexual arousal.

10. The '851 Patent is generally directed to a handheld sexual stimulation device with various components and features, including a pressure field generator that generates positive and negative pressures that are modulated with respect to a reference pressure and can be applied through an opening to female erogenous zones, particularly the clitoris. The following figure from the front page of the patent shows one embodiment of the patented invention on the left and a detailed view of a pressure field generator on the right:

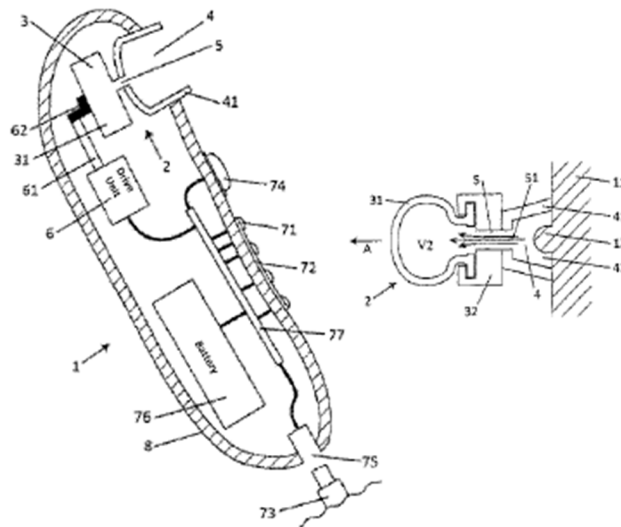

Exhibit 1, 1.

11. The commercial embodiments of the '851 Patent are branded under the original German name, “Womanizer®”, a name given by the German inventor, inspired by the idea that the invention would revolutionize sexual arousal for women. Although the word “Womanizer” in German is a positive descriptor, when translated to English, the name bears unfortunate colloquial

negative connotations that the inventor only later learned about from various U.S. commentators. The products experienced such rapid success due to the product's patented features, however, that a name change in the United States quickly became impractical.

12. The commercial embodiments of the '851 Patent include, among others, the Womanizer® "Classic," "Premium," "Starlet," "Pro," "InsideOut," and "Duo" products (referred to collectively as "the Commercial Embodiments"). The Commercial Embodiments have been described by media, customers, and experts as "an entirely new type of sex toy," "totally unique," and "nothing short of perfection." The following images show a Womanizer Premium:



Exhibit 2.

13. After Novoluto filed the application that led to the '851 Patent and launched its first commercial embodiment, the industry saw an influx of devices attempting to capitalize on the innovative technology disclosed in the '851 Patent, including the Accused Product.

14. The patented technology was so successful that in July 2019, one of the companies notorious for infringing Novoluto's patents tried to clear the path for infringing products by challenging the '851 Patent's validity in an *inter partes* review (IPR) before the USPTO's Patent Trial and Appeal Board ("the PTAB"). *EIS, GmbH v. Novoluto GmbH*, Case No. IPR2019-01444. That validity attack was unsuccessful, as were the two other attempts made to invalidate

Novoluto's other U.S. patents. *See* Case Nos. IPR2019-01302, Paper 50 (P.T.A.B. June 14, 2021), and IPR2020-00007, Paper 41 (P.T.A.B. Sept. 23, 2021).

15. On August 5, 2021, the PTAB issued its final written decision relating to the '851 Patent, finding in favor of Novoluto and upholding all challenged claims as patentable on all grounds. IPR2019-01444, Paper 45 (P.T.A.B. Aug. 5, 2021) (Exhibit 3).

16. Around the time the '851 Patent was first challenged in IPR, the New York Times published an article featuring Defendant Clio and its CEO, titled "The Man Who's Putting More Sex Toys on Walmart's Shelves." Exhibit 4. The article featured Defendant's "plusOne" line of sex toys, inspired at least in part by "premium products made by companies like Lelo, We-Vibe and *Womanizer*" (Exhibit 4, 10 (emphasis added)), and mentioned Clio's plans to release "a clitoral stimulator" as part of its August expansion (Exhibit 4, 4).

17. The clitoral stimulator referred to in the article is the plusOne Air Pulsing Arouser, the Accused Product in this case.



**Clio's plusOne Air Pulsing Arouser**

18. In addition to Clio’s CEO’s statements that he wanted to become “the Kleenex of sex toys,” in other words, “the brand that you associate with sex toys,” the article also reported that Clio had sold over a million units in the plusOne product line in the preceding eight months.

19. On information and belief, Defendant has been aware of the Asserted Patent and the Commercial Embodiments since before the commercial release of the Accused Product, and no later than July 2019. The July 2019 New York Times article confirms Defendant’s knowledge of Plaintiff’s patent and familiarity with the associated commercial embodiment product lines at least as early as when the interview was performed leading to the article. Exhibit 4. Significantly, the article features two photographs that make clear Clio based its plusOne Air on the ’851 Patent and one of its commercial embodiments.

20. First, the article features a photograph showing the CEO sitting at a table, behind which there are various hand-drawn sketches, including some for the plusOne Air.





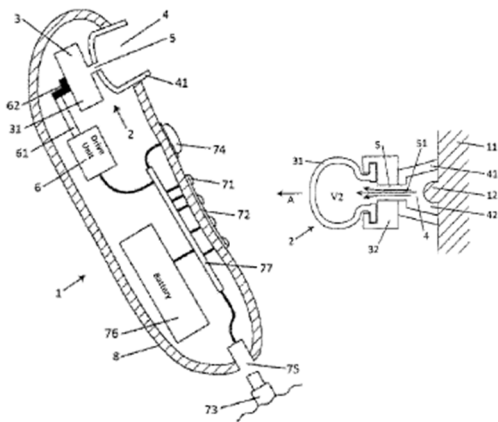

Exhibit 4, 1 (annotations added).

21. A closer look shows the striking similarities between sketches for the plusOne Air and the drawings on the front page of the '851 Patent:

**The '851 Patent**

**Clio's plusOne Sketches**



22. Second, the article features a photograph showing a Womanizer Premium, one of the commercial embodiments of the '851 Patent, hanging on the wall along with various other competitors' infringing knockoffs.

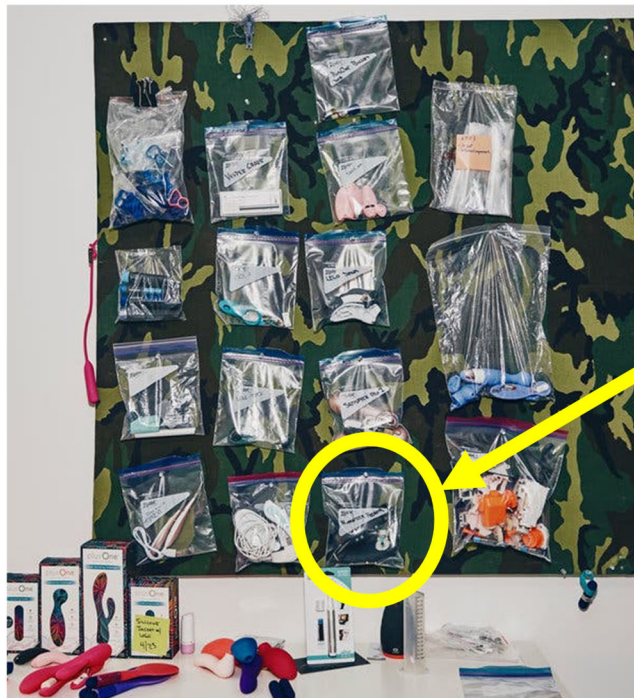

Bag containing disassembled Womanizer® product and labeled "Womanizer Premium"

Exhibit. 4, 8 (annotations added).

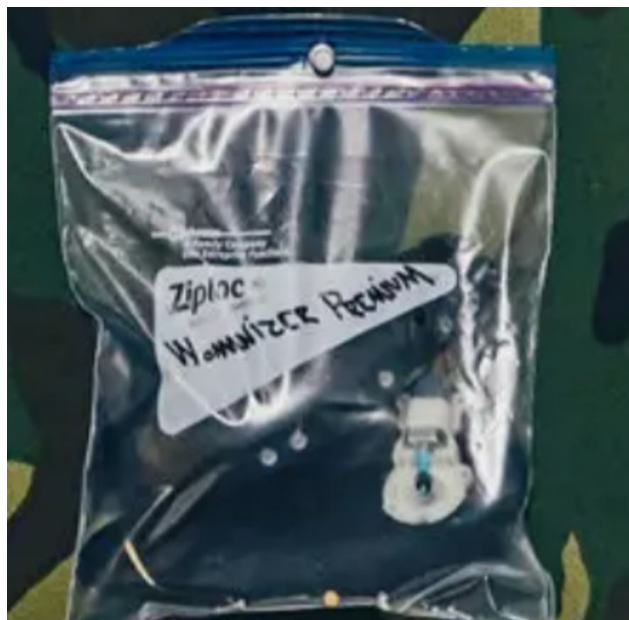



*Id.* (zoomed in excerpt). Explicitly copying the features of the Womanizer Premium while incorporating only patentably irrelevant differences, the Defendant willfully infringed the '851 Patent with its plusOne Air Pulsing Arouser.

23. Like the Womanizer Premium, Clio's plusOne Air is a handheld sexual stimulation device that includes, among other features, an opening through which modulated positive and negative pressures are applied to the clitoris.

24. Clio commercially released the plusOne Air in late 2019, and the product is now sold in stores all over the United States, including CVS, Walmart, Target, and Amazon, in addition to through Clio's own website, as shown in these images:

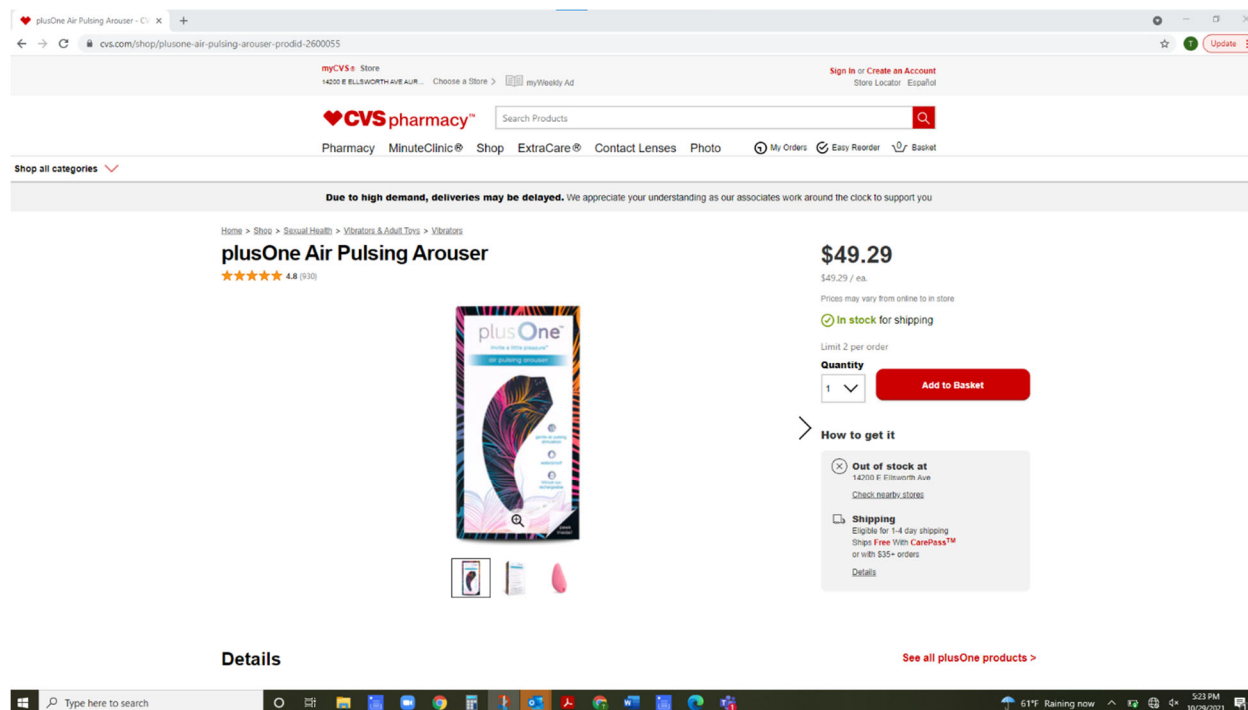

Exhibit 5 (available at <https://www.cvs.com/shop/plusone-air-pulsing-arouser-prodid-2600055>);

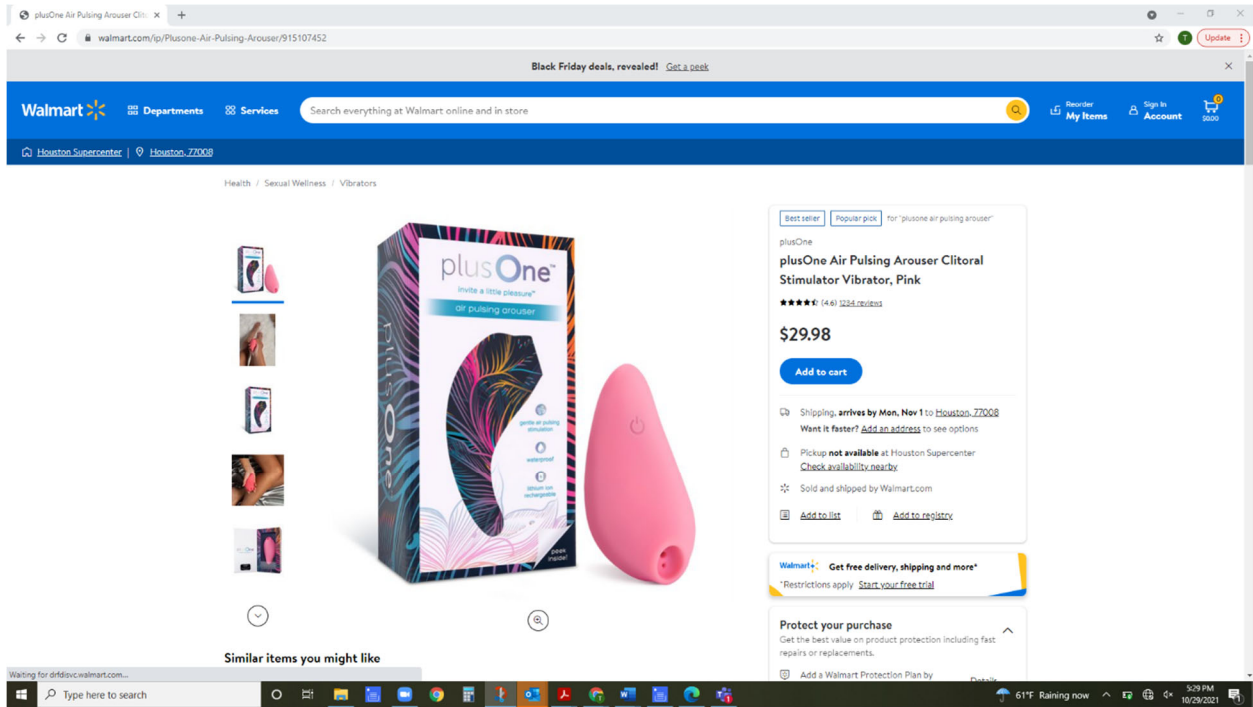

Exhibit 6 (available at <https://www.walmart.com/ip/Plusone-Air-Pulsing-Arouser/915107452>);

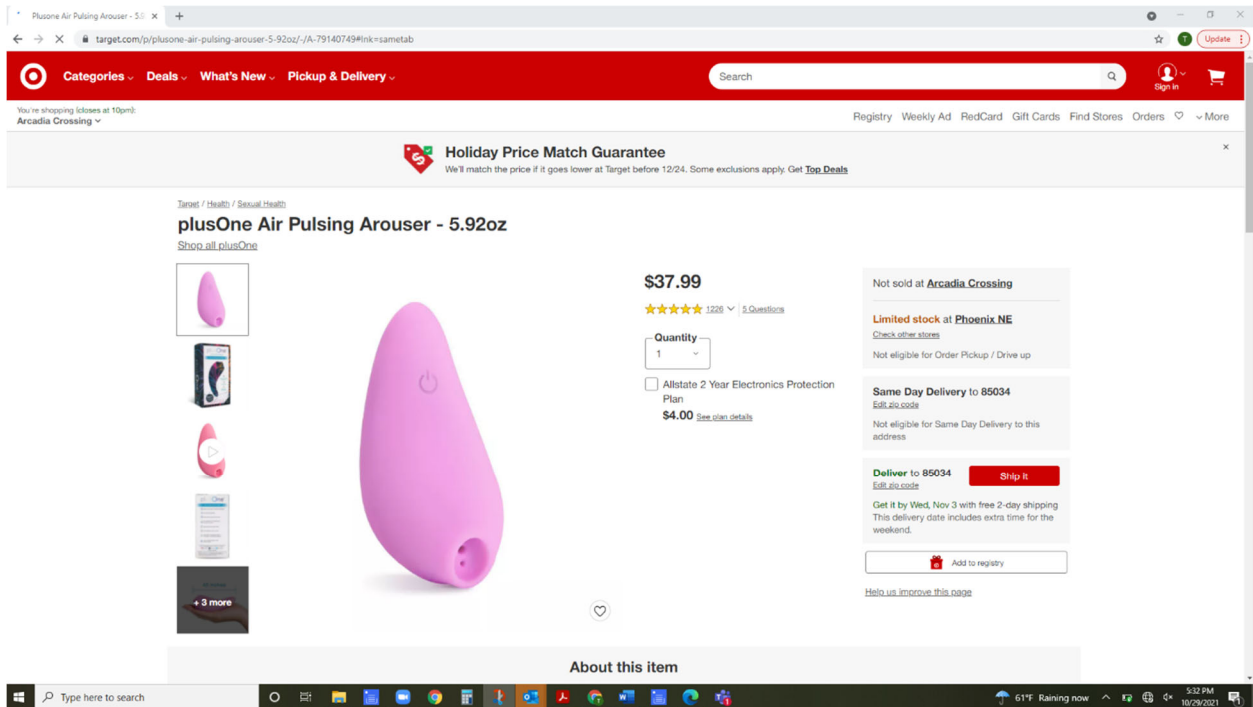

Exhibit 7 (available at <https://www.target.com/p/plusone-air-pulsing-aarouser-5-92oz/-/A-79140749>);

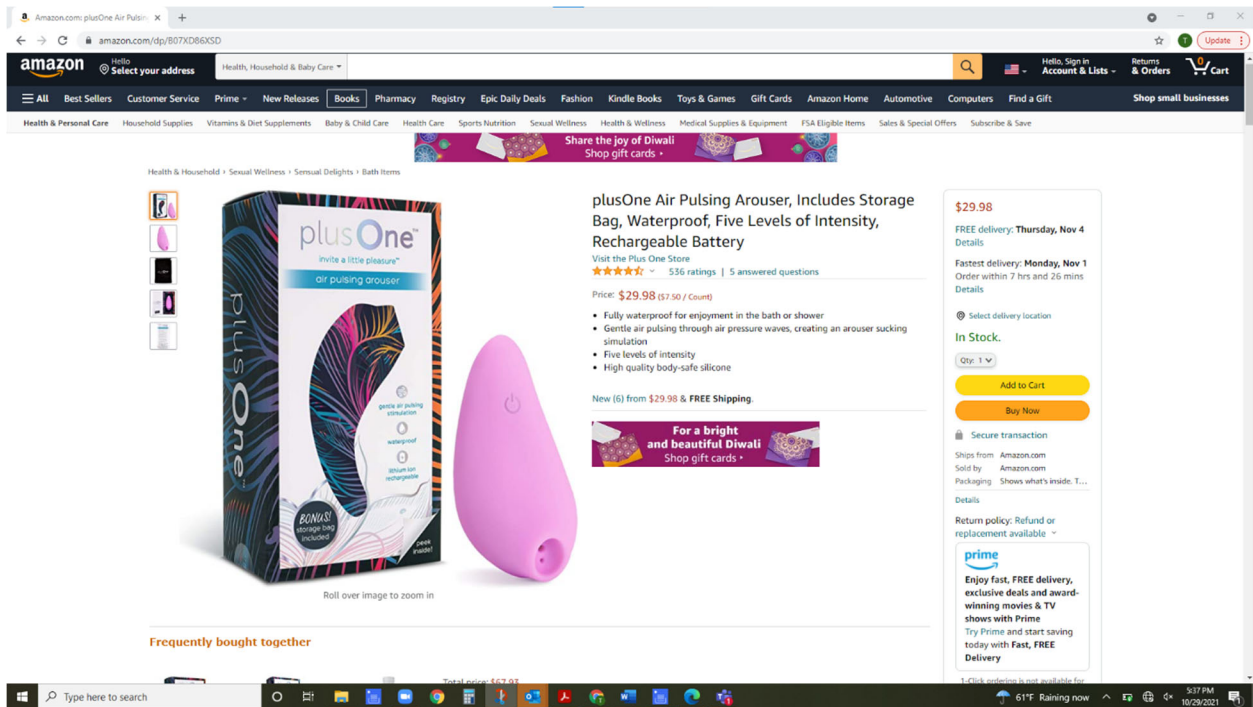

Exhibit 8 (available at <https://www.amazon.com/dp/B07XD86XSD>);

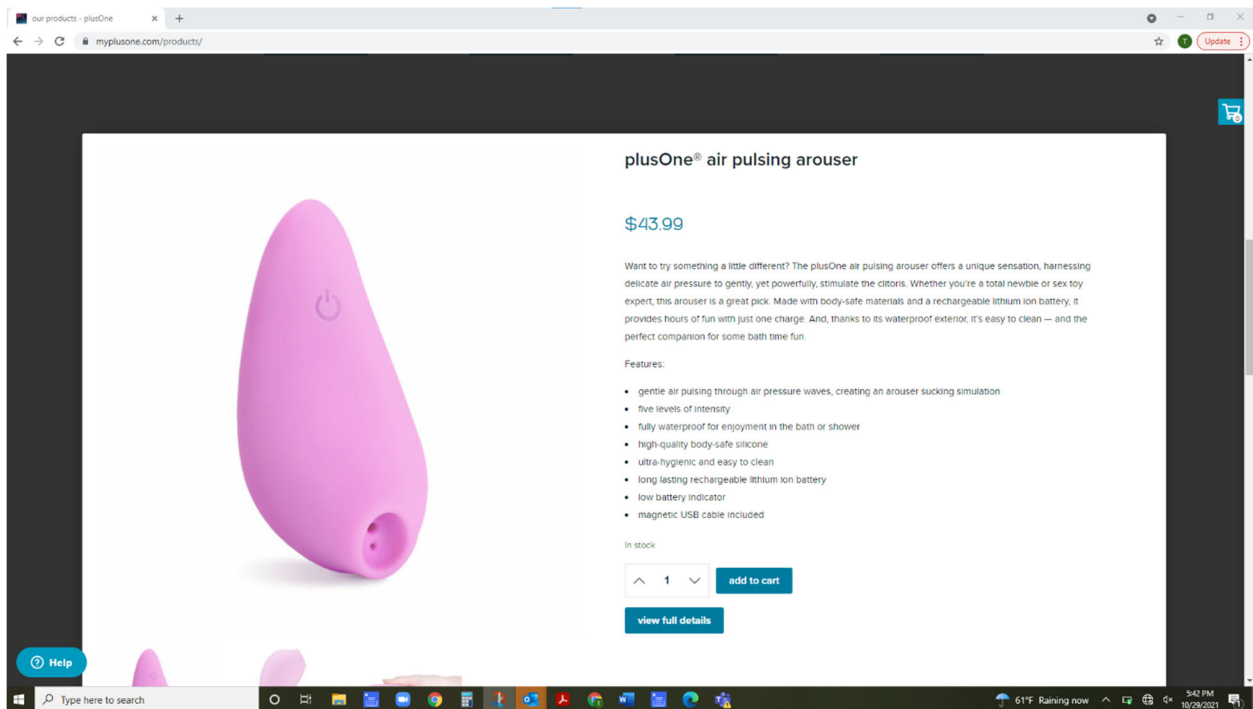

Exhibit 9 (available at <https://myplusone.com/our-products>).

25. Defendant's plusOne Air Pulsing Arouser includes each and every limitation of the '851 Patent, while being "priced ... far less than 'designer vibrators.'" Exhibit 2, 3.

26. As explained in more detail below and in the associated claim chart included with this complaint (Exhibit 10), Defendant and its Accused Product infringe the Asserted Patent.

**COUNT I**  
**INFRINGEMENT OF U.S. PATENT NO. 9,763,851**

27. Plaintiff realleges and incorporates by reference the allegations in the preceding paragraphs.

28. The '851 Patent is titled "Stimulation Device." On September 19, 2017, the '851 Patent was duly and legally issued by the U.S. Patent and Trademark Office (USPTO). Novoluto is the assignee of the entire right, title, and interest in and to the '851 Patent, including all rights to enforce this patent against infringers. A true and correct copy of the '851 Patent is attached as Exhibit 1.

29. On information and belief, Defendant has had knowledge of the '851 Patent since at least as early as a few months before July 2019, when the company announced in a New York Times article the then-pending commercial release of the Accused Product in August 2019.

30. Defendant has infringed at least claim 1 of the '851 Patent at least by making, using, selling, offering to sell, and/or importing stimulation devices, such as the devices referred to as plusOne Air, sold in the United States at brick and mortar stores and online through at least CVS (available at <https://www.cvs.com/shop/plusone-air-pulsing-arouser-prodid-2600055>), Walmart (available at <https://www.walmart.com/ip/Plusone-Air-Pulsing-Arouser/915107452>), Target (available at <https://www.target.com/p/plusone-air-pulsing-aarouser-5-92oz/-/A-79140749>), and Amazon (available at <https://www.amazon.com/dp/B07XD86XSD>), in addition to through Clio's own website (available at <https://myplusone.com/our-products>).

31. The Accused Product directly infringes at least claim 1 of the '851 Patent under 35 U.S.C. § 271(a), as shown in the claim chart attached as Exhibit 10.

32. Novoluto has been damaged as a result of Defendant's infringing conduct. Thus, Defendant is liable to Novoluto in an amount that adequately compensates it for such infringement, which, by law, cannot be less than a reasonable royalty, together with interest and costs as fixed by this Court under 35 U.S.C. § 284.

33. On information and belief, Defendant's infringement of the '851 Patent has been willful at least because despite being aware of the '851 Patent at least as early as a few months before July 2019, and being aware of the similarities between the Accused Product and the Commercial Embodiments, such infringing conduct continues in conscious disregard of Novoluto's rights in the '851 Patent.

34. Novoluto has satisfied all statutory obligations required to collect pre-filing damages for the full period allowed by law for Defendant's infringement of the '851 Patent.

**PRAYER FOR RELIEF**

Novoluto requests the Court find in its favor and grant the following relief:

A. Judgment that one or more claims of the Asserted Patent have been infringed, either literally and/or under the doctrine of equivalents, by Defendant;

B. Judgment that Defendant's infringement has been willful;

C. A permanent injunction enjoining Defendant and its officers, directors, agents, affiliates, employees, divisions, branches, subsidiaries, parents, and all others acting in concert therewith from the infringement of the Asserted Patent; or, in the alternative, an award of ongoing damages for future infringement.

D. Judgment that Defendant account for and pay to Novoluto all damages to



and costs incurred by Novoluto because of Defendant's infringing activities and other conduct complained of herein, including an award of all increased damages to which Novoluto is entitled under 35 U.S.C. § 284;

E. That Novoluto be granted pre-judgment and post-judgment interest on the damages caused by Defendant's infringing activities and other complained-of-conduct;

F. That this Court declare this an exceptional case and award Novoluto its reasonably attorney's fees and costs in accordance with 35 U.S.C. § 285; and

G. That Novoluto be granted such other and further relief as the Court may deem just and proper under the circumstances.

**JURY DEMAND**

Plaintiff hereby demands a trial by jury on all issues triable as of right by a jury.

Dated: November 16, 2021

Respectfully submitted,

*/s/ Andrew T. O'Connor*

---

Andrew T. O'Connor (BBO# 664811)

Rebecca Harris (BBO# 699598)

GOULSTON & STORRS PC

400 Atlantic Avenue

Boston, MA 02110-3333

Phone: (617) 574-4153

Fax: (617) 574-4112

*aoconnor@goulstonstorrs.com*

*rharris@goulstonstorrs.com*

Tammy J. Terry (*pro hac vice* forthcoming)

*Terry@obwbip.com*

Lisa Margonis (*pro hac vice* forthcoming)

*Margonis@obwbip.com*

OSHA BERGMAN WATANABE & BURTON LLP

909 Fannin, Suite 3500

Houston, TX 77010

Phone | Fax: (713) 228-8600 | (713) 228-8778

***Attorneys for Plaintiff***

***Novoluto GmbH***