

**IN THE UNITED STATES DISTRICT COURT
FOR THE WESTERN DISTRICT OF TEXAS
WACO DIVISION**

AMERICAN PATENTS LLC,

Plaintiff,

v.

MOFI NETWORK INC.,

Defendant.

CIVIL ACTION NO. 6:21-cv-1334

ORIGINAL COMPLAINT FOR
PATENT INFRINGEMENT

JURY TRIAL DEMANDED

ORIGINAL COMPLAINT FOR PATENT INFRINGEMENT

Plaintiff American Patents LLC (“American Patents” or “Plaintiff”) files this original complaint against Defendant Mofi Network Inc. (“Mofi”), alleging, based on its own knowledge as to itself and its own actions and based on information and belief as to all other matters, as follows:

PARTIES

1. American Patents is a limited liability company formed under the laws of the State of Texas, with its principal place of business at 2325 Oak Alley, Tyler, Texas, 75703.
2. Mofi Network Inc. (“Mofi”) is a corporation duly organized and existing under the laws of Canada having a place of business at 15 SIMS CRES Unit 3A, Richmond Hill, ON, L4B-1C9 Canada.
3. Mofi and its foreign and United States subsidiaries, affiliates, and related companies (“Mofi and its affiliates”) comprise one of the largest manufacturers of LTE and WiFi routers and devices, including the Mofi brand.

4. Mofi and its affiliates are part of the same corporate structure and distribution chain for the making, importing, offering to sell, selling, and using of the accused devices in the United States, including in the State of Texas generally and this judicial district in particular.

5. Mofi and its affiliates share the same management, common ownership, advertising platforms, facilities, distribution chains and platforms, and accused product lines and products involving related technologies.

6. Mofi and its affiliates regularly contract with customers regarding equipment or services that will be provided by their affiliates on their behalf.

7. Thus, Mofi and its affiliates operate as a unitary business venture and are jointly and severally liable for the acts of patent infringement alleged herein.

JURISDICTION AND VENUE

8. This is an action for infringement of United States patents arising under 35 U.S.C. §§ 271, 281, and 284–85, among others. This Court has subject matter jurisdiction of the action under 28 U.S.C. § 1331 and § 1338(a).

9. This Court has personal jurisdiction over Mofi pursuant to due process and/or the Texas Long Arm Statute because, *inter alia*, (i) Mofi has done and continues to do business in Texas; and (ii) Mofi has committed and continues to commit acts of patent infringement in the State of Texas, including making, using, offering to sell, and/or selling accused products in Texas, and/or importing accused products into Texas, including by Internet sales and sales via retail and wholesale stores, inducing others to commit acts of patent infringement in Texas, and/or committing a least a portion of any other infringements alleged herein. In the alternative, Mofi Network Inc. is subject to this Court's specific personal jurisdiction consistent with the principles of due process and the Federal Long-Arm Statute of Fed. R. Civ. P. 4(k)(2) because:

(1) it has substantial contacts with the United States and committed and/or induced acts of patent infringement in the United States; and (2) it is not subject to jurisdiction in any state's courts of general jurisdiction.

10. Venue is proper as to Mofi Network Inc., which is organized under the laws of Canada. 28 U.S.C. § 1391(c)(3) provides that “a defendant not resident in the United States may be sued in any judicial district, and the joinder of such a defendant shall be disregarded in determining where the action may be brought with respect to other defendants.”

BACKGROUND

11. The patents-in-suit generally pertain to communications networks and other technology used in “smart” devices such as smartphones, smart TVs, and smart appliances. The technology disclosed by the patents was developed by personnel at Georgia Institute of Technology (“Georgia Tech”).

12. Georgia Tech is a leading public research university located in Atlanta, Georgia. Founded in 1885, Georgia Tech is often ranked as one of the top ten public universities in the United States. The patents from Georgia Tech (“the Mody patents”) were developed by a professor and a graduate student in Georgia Tech’s Electrical and Computer Engineering department. The undergraduate and graduate programs of this department are often ranked in the top five of their respective categories.

13. The Mody patents are related to Multi-Input, Multi-Output (MIMO) technology. The inventors of the Mody patents were at the forefront of MIMO, developing, disclosing, and patenting a solution for achieving both time and frequency synchronization in MIMO systems. The Mody patents (or the applications leading to them) have been cited during patent prosecution hundreds of times, by numerous leading companies in the computing and communications

industries, including AMD, Alcatel Lucent, Altair, AT&T, Atheros, Blackberry, Broadcom, Comcast, Ericsson, Facebook, HP, Hitachi, Huawei, Infineon, Intel, Interdigital, IBM, Kyocera, Marvell, Matsushita, Mediatek, Motorola, NEC, Nokia, Nortel Networks, NXP, Panasonic, Philips, Qualcomm, Realtek, Samsung, Sanyo, Sharp, Sony, STMicroelectronics, Texas Instruments, and Toshiba.

COUNT I

INFRINGEMENT OF U.S. PATENT NO. 7,088,782

14. On August 8, 2006, United States Patent No. 7,088,782 (“the ‘782 Patent”) was duly and legally issued by the United States Patent and Trademark Office for an invention entitled “Time And Frequency Synchronization In Multi-Input, Multi-Output (MIMO) Systems.”

15. American Patents is the owner of the ‘782 Patent, with all substantive rights in and to that patent, including the sole and exclusive right to prosecute this action and enforce the ‘782 Patent against infringers, and to collect damages for all relevant times.

16. Mofi used products and/or systems including, for example, its MOFI4500-4GXeLTE-SIM8-VEHICLE-COMBO-V3, MOFI5500-5GXeLTE-EM7411-COMBO, and MOFI5500-5GXeLTE-EM9191-COMBO CAT families of products, that include LTE and/or 802.11n and above wireless capabilities (“accused products”):



SHOP SUPPORT

SEARCH SITE



HOME / ROUTERS / 4G/LTE (NO 5G)
**MOFI4500-4GXeLTE-
SIM8-VEHICLE-COMBO
V3**

\$354.99

QUANTITY	PRICE
1	\$354.99
2 - 4	\$349.99
5 - 9	\$344.99
10+	\$339.99

- 1 + **ADD TO CART**



(Source: <https://mofinetwork.com/product/mofi4500-4gxelte-sim8-vehicle-combo-v3/>)

TOLL FREE 1-888-499-0123

About Us | Contact | FAQ | Login | Cart / \$0.00



SHOP ▾ SUPPORT

SEARCH SITE



HOME / ROUTERS / 4G/LTE (NO 5G)

MOFI5500-5GXeLTE-EM7411-COMBO (IN STOCK)

\$399.99

MOFI5500-5GXeLTE-EM7411-COMBO

(Source: <https://mofinetwork.com/product/mofi5500-5gxelte-em7411-combo/>)

TOLL FREE 1-888-499-0123 About Us Contact FAQ Login Cart / \$0.00

MoFi NETWORK SHOP SUPPORT SEARCH SITE



HOME / ROUTERS / 4G/LTE/5G

MOFI5500-5GXeLTE-EM9191-COMBO CAT20 LTE + 5G ROUTER (IN STOCK)

\$699.99

MOFI5500-5GXeLTE-EM9191-COMBO

(Source: <https://mofinetwork.com/product/mofi5500-5gxelte-em9191-combo-cat20-lte-5g-router-pre-order-expected-to-ship-on-july-06-2021/>)

Internal Module Specs:

LTE Category 7: 300Mbps DL, 150Mbps UL (note the max this model can handle is up to 100mb/s)

HSPA+: 42Mbps DL, 5.76 UL

TD-HSDPA/HSUPA: 2.8Mbps DL, 2.2Mbps UL

EDGE: Multi Slot Class 12 236.8 kbps DL & UL

GPRS: Multi Slot Class 10 85.6 kbps DL & UL

Frequency Bands:

B2, B4, B5, B7, B12, B13, B14, B17, B25, B26, B41, B42, B43, B48, B66, B71

(Source: <https://mofinetwork.com/product/mofi4500-4gxelte-sim8-vehicle-combo-v3/>)

Internal Module Specs:

NOTE THIS IS NOT A 5G ROUTER

This item is made to work in North America but may also work in many other countries around the world.

For North America, no need to check the bands but if using outside Canada/USA, check the band support for compatibility.

LTE Category 7: 300Mbps DL, 150Mbps UL

Supports up to 2 x Carrier Aggregation

HSPA+: 42Mbps DL, 5.76 UL

TD-HSDPA/HSUPA: 2.8Mbps DL, 2.2Mbps UL

EDGE: Multi Slot Class 12 236.8 kbps DL & UL

GPRS: Multi Slot Class 10 85.6 kbps DL & UL

Frequency Bands:

B2, B4, B5, B7, B12, B13, B14, B17, B25, B26, B41, B42, B43, B48, B66, B71

(Source: <https://mofinetwork.com/product/mofi5500-5gxelte-em7411-combo/>)

Internal Module Specs:

This item is made to work in anywhere on the planet!

5G LTE Category 20: 2000Mbps (4.5Gbps) DL, 660Mbps UL

5 x Carrier Aggregations

HSPA+: 42Mbps DL, 5.76 UL

TD-HSDPA/HSUPA: 2.8Mbps DL, 2.2Mbps UL

EDGE: Multi Slot Class 12 236.8 kbps DL & UL

GPRS: Multi Slot Class 10 85.6 kbps DL & UL

Frequency Bands:

4G/LTE Bands: B1, B2, B3, B4, B5, B7, B8, B9, B12, B13, B14, B17, B18, B19, B20, B21, B25, B26, B28, B29, B30, B32, B34, B38, B39, B40, B41, B42, B43, B46, B48, B66, B71

5G Bands: For 5G: N1, N2, N3, N5, N7, N8, N12, N20, N25, N28, N38, N40, N41, N48, N66, N71, N77, N78, N79

If you want to see if the router is compatible with your provider on the signal side, see what 4G/LTE/5G bands your provider will use and compare to what is available. It will be very hard to find a provider that is not compatible with this product.

(Source: <https://mofinetwork.com/product/mofi5500-5gxelte-em9191-combo-cat20-lte-5g-router-pre-order-expected-to-ship-on-july-06-2021/>)

User equipment Category	Max. LI datarate Downlink (Mbit/s)	Max. number of DL MIMO layers	Max. LI datarate Uplink (Mbit/s)	3GPP Release
NB-I	0.68	1	1.0	Rel 13
MI	1.0	1	1.0	
0	1.0	1	1.0	Rel 12
1	10.3	1	5.2	Rel 8
2	51.0	2	25.5	
3	102.0	2	51.0	
4	150.8	2	51.0	
5	299.6	4	75.4	
6	301.5	2 or 4	51.0	Rel 10
7	301.5	2 or 4	102.0	
8	2,998.6	8	1,497.8	
9	452.2	2 or 4	51.0	Rel 11
10	452.2	2 or 4	102.0	
11	603.0	2 or 4	51.0	
12	603.0	2 or 4	102.0	

(Source: <https://www.cablefree.net/wirelesstechnology/4glte/lte-ue-category-class-definitions>)

17. By doing so, Mofi has directly infringed (literally and/or under the doctrine of equivalents) at least Claim 30 of the '782 Patent. Mofi's infringement in this regard is ongoing.

18. Mofi has infringed the '782 Patent by using the accused products and thereby practicing a method for synchronizing a Multi-Input Multi-Output (MIMO) Orthogonal Frequency Division Multiplexing (OFDM) system in time and frequency domains. For example, the accused products support the LTE standard and MIMO technology. According to the LTE standards, the physical layer performs various functions which include modulation and demodulation of physical channels as well as time and frequency synchronization.

Internal Module Specs:

LTE Category 7: 300Mbps DL, 150Mbps UL (note the max this model can handle is up to 100mb/s)
HSPA+: 42Mbps DL, 5.76 UL
TD-HSDPA/HSUPA: 2.8Mbps DL, 2.2Mbps UL
EDGE: Multi Slot Class 12 236.8 kbps DL & UL
GPRS: Multi Slot Class 10 85.6 kbps DL & UL
Frequency Bands:
B2, B4, B5, B7, B12, B13, B14, B17, B25, B26, B41, B42, B43, B48, B66, B71

(Source: <https://mofinetwork.com/product/mofi4500-4gxelte-sim8-vehicle-combo-v3/>)

Internal Module Specs:

NOTE THIS IS NOT A 5G ROUTER

This item is made to work in North America but may also work in many other countries around the world.

For North America, no need to check the bands but if using outside Canada/USA, check the band support for compatibility.

LTE Category 7: 300Mbps DL, 150Mbps UL

Supports up to 2 x Carrier Aggregation

HSPA+: 42Mbps DL, 5.76 UL

TD-HSDPA/HSUPA: 2.8Mbps DL, 2.2Mbps UL

EDGE: Multi Slot Class 12 236.8 kbps DL & UL

GPRS: Multi Slot Class 10 85.6 kbps DL & UL

Frequency Bands:

B2, B4, B5, B7, B12, B13, B14, B17, B25, B26, B41, B42, B43, B48, B66, B71

(Source: <https://mofinetwork.com/product/mofi5500-5gxelte-em7411-combo/>)

Internal Module Specs:

This item is made to work in anywhere on the planet!

5G LTE Category 20: 2000Mbps (4.5Gbps) DL, 660Mbps UL

5 x Carrier Aggregations

HSPA+: 42Mbps DL, 5.76 UL

TD-HSDPA/HSUPA: 2.8Mbps DL, 2.2Mbps UL

EDGE: Multi Slot Class 12 236.8 kbps DL & UL

GPRS: Multi Slot Class 10 85.6 kbps DL & UL

Frequency Bands:

4G/LTE Bands: B1, B2, B3, B4, B5, B7, B8, B9, B12, B13, B14, B17, B18, B19, B20, B21, B25, B26, B28, B29, B30, B32, B34, B38, B39, B40, B41, B42, B43, B46, B48, B66, B71

5G Bands: For 5G: N1, N2, N3, N5, N7, N8, N12, N20, N25, N28, N38, N40, N41, N48, N66, N71, N77, N78, N79

If you want to see if the router is compatible with your provider on the signal side, see what 4G/LTE/5G bands your provider will use and compare to what is available. It will be very hard to find a provider that is not compatible with this product.

(Source: <https://mofinetwork.com/product/mofi5500-5gxelte-em9191-combo-cat20-lte-5g-router-pre-order-expected-to-ship-on-july-06-2021/>)

User equipment Category	Max. L1 datarate Downlink (Mbit/s)	Max. number of DL MIMO layers	Max. L1 datarate Uplink (Mbit/s)	3GPP Release
NB-I	0.68	1	1.0	Rel 13
MI	1.0	1	1.0	
0	1.0	1	1.0	Rel 12
1	10.3	1	5.2	Rel 8
2	51.0	2	25.5	
3	102.0	2	51.0	
4	150.8	2	51.0	
5	299.6	4	75.4	
6	301.5	2 or 4	51.0	Rel 10
7	301.5	2 or 4	102.0	
8	2,998.6	8	1,497.8	
9	452.2	2 or 4	51.0	Rel 11
10	452.2	2 or 4	102.0	
11	603.0	2 or 4	51.0	
12	603.0	2 or 4	102.0	

(Source: <https://www.cablefree.net/wirelesstechnology/4glte/lte-ue-category-class-definitions>)

5.2 Overview of L1 functions

The physical layer offers data transport services to higher layers. The access to these services is through the use of a transport channel via the MAC sub-layer. The physical layer is expected to perform the following functions in order to provide the data transport service:

- Error detection on the transport channel and indication to higher layers
- FEC encoding/decoding of the transport channel
- Hybrid ARQ soft-combining
- Rate matching of the coded transport channel to physical channels
- Mapping of the coded transport channel onto physical channels
- Power weighting of physical channels
- Modulation and demodulation of physical channels
- Frequency and time synchronisation
- Radio characteristics measurements and indication to higher layers
- Multiple Input Multiple Output (MIMO) antenna processing
- Transmit Diversity (TX diversity)
- Beamforming
- RF processing.

(Source:

https://www.etsi.org/deliver/etsi_ts/136300_136399/136302/15.00.00_60/ts_136302v150000p.pdf)

Synchronization Signals (PSS and SSS)

In LTE, there are two downlink synchronization signals which are used by the UE to obtain the cell identity and frame timing.

- Primary synchronization signal (PSS)
- Secondary synchronization signal (SSS)

The division into two signals is aimed to reduce the complexity of the cell search process.

(Source: <https://in.mathworks.com/help/lte/ug/synchronization-signals-pss-and-sss.html>)

19. The methods practiced by Mofi's use of the accused products include producing a frame of data comprising a training symbol that includes a synchronization component that aids in synchronization, a plurality of data symbols, and a plurality of cyclic prefixes. For example, the physical layer performs the modulation and demodulation of the physical channels. Further,

it uses OFDM in the downlink physical channel. Hence, there would be OFDM modulators present in transmitter of the apparatus (mobile devices such as the accused products) for modulating the data signals. The physical layer transmits downlink frames that include data symbols, pilot symbols such as PSS, SSS, reference symbols and cyclic prefixes for each symbol.

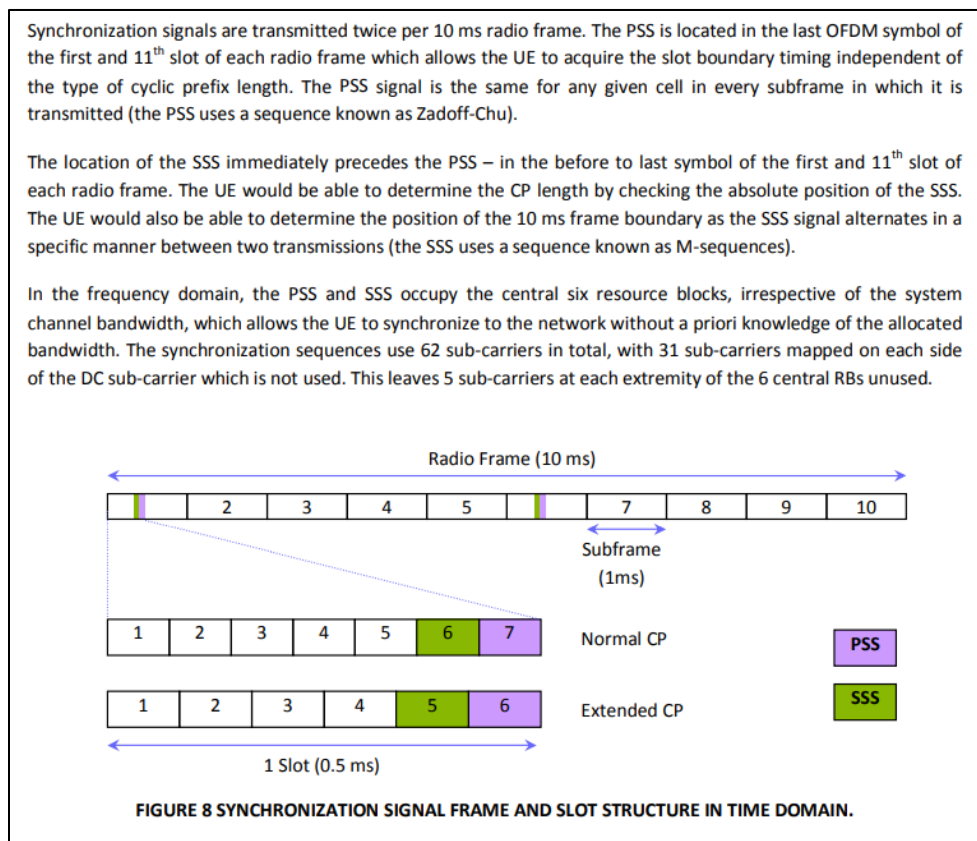

(Source: <https://home.zhaw.ch/kunr/NTM1/literatur/LTE%20in%20a%20Nutshell%20-%20Physical%20Layer.pdf>)

4.2.1 Multiple Access

The multiple access scheme for the LTE physical layer is based on Orthogonal Frequency Division Multiplexing (OFDM) with a cyclic prefix (CP) in the downlink, and on Single-Carrier Frequency Division Multiple Access (SC-FDMA) with a cyclic prefix in the uplink. To support transmission in paired and unpaired spectrum, two duplex modes

(Source:

https://www.etsi.org/deliver/etsi_ts/136200_136299/136201/10.00.00_60/ts_136201v100000p.pdf)

6.11.1 Primary synchronization signal

6.11.1.1 Sequence generation

The sequence $d(n)$ used for the primary synchronization signal is generated from a frequency-domain Zadoff-Chu sequence according to

$$d_u(n) = \begin{cases} e^{-j\frac{u(n+1)}{63}} & n = 0, 1, \dots, 30 \\ e^{-j\frac{u(n+1)(n+2)}{63}} & n = 31, 32, \dots, 61 \end{cases}$$

where the Zadoff-Chu root sequence index u is given by Table 6.11.1.1-1.

(Source:

https://www.etsi.org/deliver/etsi_ts/136200_136299/136211/08.06.00_60/ts_136211v080600p.pdf)

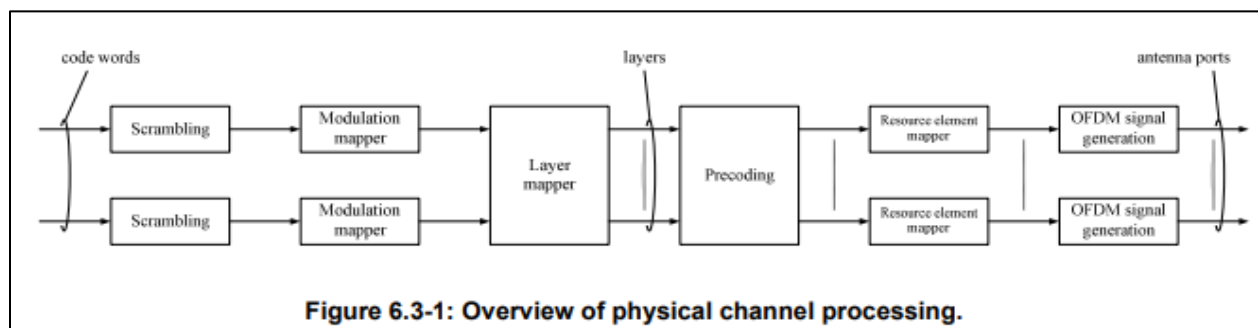

(Source:

https://www.etsi.org/deliver/etsi_ts/136200_136299/136211/08.06.00_60/ts_136211v080600p.pdf)

Preamble and Pilot

There are two different ways to transmit training symbols: preamble or pilot tones. Preambles entail sending a certain number of training symbols prior to the user data symbols. In the case of OFDM, one or two preamble OFDM symbols are typical. Pilot tones involve inserting a few known pilot symbols among the subcarriers. Channel estimation in MIMO-OFDM systems can be performed in a variety of ways, but it is typical to use the preamble for synchronization⁷ and initial channel estimation, and the pilot tones for tracking the time-varying channel in order to maintain accurate channel estimates.

In MIMO-OFDM, the received signal at each antenna is a superposition of the signals transmitted from the N_t transmit antennas. Thus, the training signals for each transmit antenna need to be transmitted without interfering with each other in order to accurately estimate the channel. [Figure 5.18](#) shows three different patterns for MIMO-OFDM that avoid interfering with each other: independent, scattered, and orthogonal patterns [\[50\]](#).

(Source: Fundamentals of LTE, Ghosh et al.)

20. The methods practiced by Mofi's use of the accused products include transmitting the frame over a channel. The data frames having cyclic prefixes and other OFDM symbols are transmitted over a channel (e.g. PDCCH). Alternatively, on request from an accused product, an LTE base station can act as a transmitter and transmit the frame over a channel.

4.2.1 Multiple Access

The multiple access scheme for the LTE physical layer is based on Orthogonal Frequency Division Multiplexing (OFDM) with a cyclic prefix (CP) in the downlink, and on Single-Carrier Frequency Division Multiple Access (SC-FDMA) with a cyclic prefix in the uplink. To support transmission in paired and unpaired spectrum, two duplex modes

(Source:

https://www.etsi.org/deliver/etsi_ts/136200_136299/136201/10.00.00_60/ts_136201v10000p.pdf)

6.7 Physical control format indicator channel

The physical control format indicator channel carries information about the number of OFDM symbols used for transmission of PDCCHs in a subframe. The set of OFDM symbols possible to use for PDCCH in a subframe is given by Table 6.7-1.

(Source:

https://www.etsi.org/deliver/etsi_ts/136200_136299/136211/11.05.00_60/ts_136211v110500p.pdf)

21. The methods practiced by Mofi's use of the accused products include receiving the transmitted frame. For example, the receiving antennas of the accused products can receive the transmitted frames for further processing.

Internal Module Specs:

LTE Category 7: 300Mbps DL, 150Mbps UL (note the max this model can handle is up to 100mb/s)
HSPA+: 42Mbps DL, 5.76 UL
TD-HSDPA/HSUPA: 2.8Mbps DL, 2.2Mbps UL
EDGE: Multi Slot Class 12 236.8 kbps DL & UL
GPRS: Multi Slot Class 10 85.6 kbps DL & UL
Frequency Bands:
B2, B4, B5, B7, B12, B13, B14, B17, B25, B26, B41, B42, B43, B48, B66, B71

(Source: <https://mofinetwork.com/product/mofi4500-4gxelte-sim8-vehicle-combo-v3/>)

Internal Module Specs:

NOTE THIS IS NOT A 5G ROUTER

This item is made to work in North America but may also work in many other countries around the world.

For North America, no need to check the bands but if using outside Canada/USA, check the band support for compatibility.

LTE Category 7: 300Mbps DL, 150Mbps UL

Supports up to 2 x Carrier Aggregation

HSPA+: 42Mbps DL, 5.76 UL

TD-HSDPA/HSUPA: 2.8Mbps DL, 2.2Mbps UL

EDGE: Multi Slot Class 12 236.8 kbps DL & UL

GPRS: Multi Slot Class 10 85.6 kbps DL & UL

Frequency Bands:

B2, B4, B5, B7, B12, B13, B14, B17, B25, B26, B41, B42, B43, B48, B66, B71

(Source: <https://mofinetwork.com/product/mofi5500-5gxelte-em7411-combo/>)

Internal Module Specs:

This item is made to work in anywhere on the planet!

5G LTE Category 20: 2000Mbps (4.5Gbps) DL, 660Mbps UL

5 x Carrier Aggregations

HSPA+: 42Mbps DL, 5.76 UL

TD-HSDPA/HSUPA: 2.8Mbps DL, 2.2Mbps UL

EDGE: Multi Slot Class 12 236.8 kbps DL & UL

GPRS: Multi Slot Class 10 85.6 kbps DL & UL

Frequency Bands:

4G/LTE Bands: B1, B2, B3, B4, B5, B7, B8, B9, B12, B13, B14, B17, B18, B19, B20, B21, B25, B26, B28, B29, B30, B32, B34, B38, B39, B40, B41, B42, B43, B46, B48, B66, B71

5G Bands: For 5G: N1, N2, N3, N5, N7, N8, N12, N20, N25, N28, N38, N40, N41, N48, N66, N71, N77, N78, N79

If you want to see if the router is compatible with your provider on the signal side, see what 4G/LTE/5G bands your provider will use and compare to what is available. It will be very hard to find a provider that is not compatible with this product.

(Source: <https://mofinetwork.com/product/mofi5500-5gxelte-em9191-combo-cat20-lte-5g-router-pre-order-expected-to-ship-on-july-06-2021/>)

User equipment Category	Max. L1 datarate Downlink (Mbit/s)	Max. number of DL MIMO layers	Max. L1 datarate Uplink (Mbit/s)	3GPP Release
NB-I	0.68	1	1.0	Rel 13
M1	1.0	1	1.0	
0	1.0	1	1.0	Rel 12
1	10.3	1	5.2	Rel 8
2	51.0	2	25.5	
3	102.0	2	51.0	
4	150.8	2	51.0	
5	299.6	4	75.4	
6	301.5	2 or 4	51.0	Rel 10
7	301.5	2 or 4	102.0	
8	2,998.6	8	1,497.8	
9	452.2	2 or 4	51.0	Rel 11
10	452.2	2 or 4	102.0	
11	603.0	2 or 4	51.0	
12	603.0	2 or 4	102.0	

(Source: <https://www.cablefree.net/wirelesstechnology/4glte/lte-ue-category-class-definitions>)

22. The methods practiced by Mofi's use of the accused products include demodulating the received frame. For example, according to the LTE standards, the physical layer performs various functions which include modulation and demodulation of physical channels. Hence, the received frame will be demodulated for further processing.

5.2 Overview of L1 functions

The physical layer offers data transport services to higher layers. The access to these services is through the use of a transport channel via the MAC sub-layer. The physical layer is expected to perform the following functions in order to provide the data transport service:

- Error detection on the transport channel and indication to higher layers
- FEC encoding/decoding of the transport channel
- Hybrid ARQ soft-combining
- Rate matching of the coded transport channel to physical channels
- Mapping of the coded transport channel onto physical channels
- Power weighting of physical channels
- Modulation and demodulation of physical channels
- Frequency and time synchronisation

(Source:

https://www.etsi.org/deliver/etsi_ts/136300_136399/136302/15.00.00_60/ts_136302v150000p.pdf)

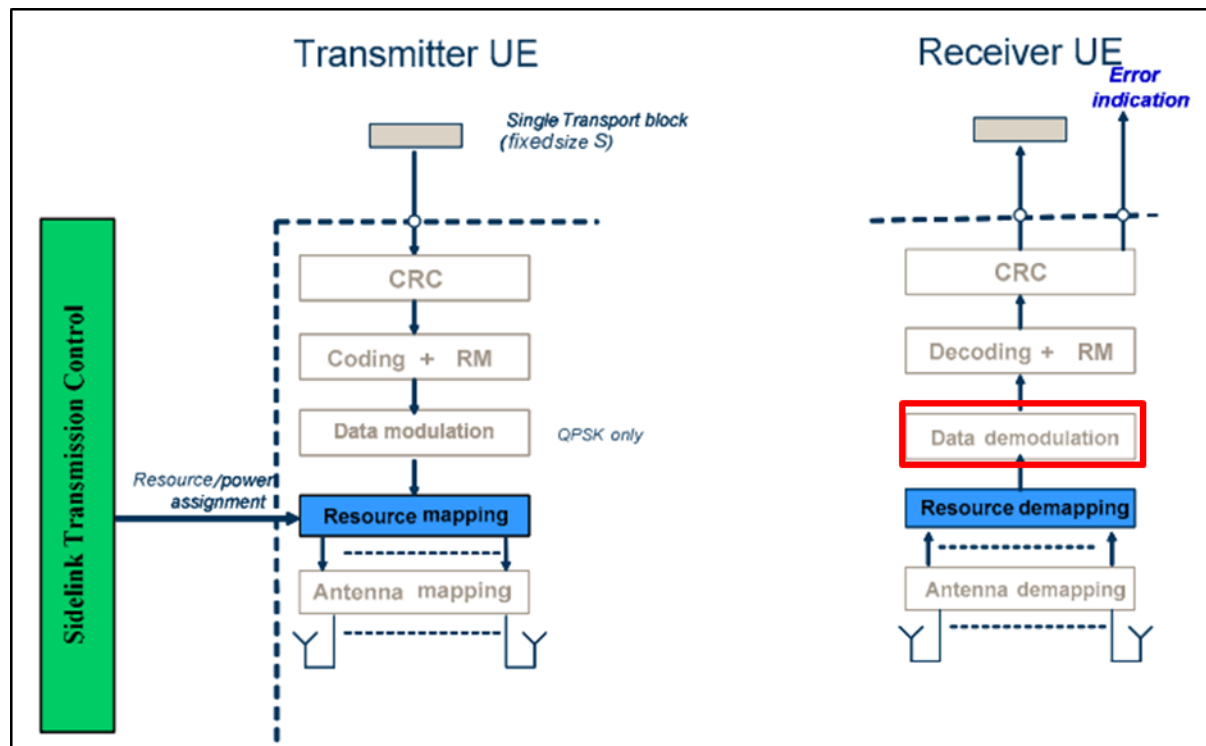

(Source:

https://www.etsi.org/deliver/etsi_ts/136300_136399/136302/15.00.00_60/ts_136302v150000p.pdf)

23. The methods practiced by Mofi's use of the accused products include synchronizing the received demodulated frame to the transmitted frame such that the data symbols are synchronized in the time domain and frequency domain. For example, according to the LTE standards, the physical layer performs various functions which include frequency and time synchronization. The procedure of achieving this time and frequency synchronizations is called 'Cell Search'.

Internal Module Specs:

LTE Category 7: 300Mbps DL, 150Mbps UL (note the max this model can handle is up to 100mb/s)

HSPA+: 42Mbps DL, 5.76 UL

TD-HSDPA/HSUPA: 2.8Mbps DL, 2.2Mbps UL

EDGE: Multi Slot Class 12 236.8 kbps DL & UL

GPRS: Multi Slot Class 10 85.6 kbps DL & UL

Frequency Bands:

B2, B4, B5, B7, B12, B13, B14, B17, B25, B26, B41, B42, B43, B48, B66, B71

(Source: <https://mofinetwork.com/product/mofi4500-4gxelte-sim8-vehicle-combo-v3/>)

Internal Module Specs:

NOTE THIS IS NOT A 5G ROUTER

This item is made to work in North America but may also work in many other countries around the world.

For North America, no need to check the bands but if using outside Canada/USA, check the band support for compatibility.

LTE Category 7: 300Mbps DL, 150Mbps UL

Supports up to 2 x Carrier Aggregation

HSPA+: 42Mbps DL, 5.76 UL

TD-HSDPA/HSUPA: 2.8Mbps DL, 2.2Mbps UL

EDGE: Multi Slot Class 12 236.8 kbps DL & UL

GPRS: Multi Slot Class 10 85.6 kbps DL & UL

Frequency Bands:

B2, B4, B5, B7, B12, B13, B14, B17, B25, B26, B41, B42, B43, B48, B66, B71

(Source: <https://mofinetwork.com/product/mofi5500-5gxelte-em7411-combo/>)

Internal Module Specs:

This item is made to work in anywhere on the planet!

5G LTE Category 20: 2000Mbps (4.5Gbps) DL, 660Mbps UL

5 x Carrier Aggregations

HSPA+: 42Mbps DL, 5.76 UL

TD-HSDPA/HSUPA: 2.8Mbps DL, 2.2Mbps UL

EDGE: Multi Slot Class 12 236.8 kbps DL & UL

GPRS: Multi Slot Class 10 85.6 kbps DL & UL

Frequency Bands:

4G/LTE Bands: B1, B2, B3, B4, B5, B7, B8, B9, B12, B13, B14, B17, B18, B19, B20, B21, B25, B26, B28, B29, B30, B32, B34, B38, B39, B40, B41, B42, B43, B46, B48, B66, B71

5G Bands: For 5G: N1, N2, N3, N5, N7, N8, N12, N20, N25, N28, N38, N40, N41, N48, N66, N71, N77, N78, N79

If you want to see if the router is compatible with your provider on the signal side, see what 4G/LTE/5G bands your provider will use and compare to what is available. It will be very hard to find a provider that is not compatible with this product.

(Source: <https://mofinetwork.com/product/mofi5500-5gxelte-em9191-combo-cat20-lte-5g-router-pre-order-expected-to-ship-on-july-06-2021/>)

User equipment Category	Max. L1 datarate Downlink (Mbit/s)	Max. number of DL MIMO layers	Max. L1 datarate Uplink (Mbit/s)	3GPP Release
NB-I	0.68	1	1.0	Rel 13
MI	1.0	1	1.0	
0	1.0	1	1.0	Rel 12
1	10.3	1	5.2	Rel 8
2	51.0	2	25.5	
3	102.0	2	51.0	
4	150.8	2	51.0	
5	299.6	4	75.4	
6	301.5	2 or 4	51.0	Rel 10
7	301.5	2 or 4	102.0	
8	2,998.6	8	1,497.8	
9	452.2	2 or 4	51.0	Rel 11
10	452.2	2 or 4	102.0	
11	603.0	2 or 4	51.0	
12	603.0	2 or 4	102.0	

(Source: <https://www.cablefree.net/wirelesstechnology/4glte/lte-ue-category-class-definitions>)

5.2 Overview of L1 functions

The physical layer offers data transport services to higher layers. The access to these services is through the use of a transport channel via the MAC sub-layer. The physical layer is expected to perform the following functions in order to provide the data transport service:

- Error detection on the transport channel and indication to higher layers
- FEC encoding/decoding of the transport channel
- Hybrid ARQ soft-combining
- Rate matching of the coded transport channel to physical channels
- Mapping of the coded transport channel onto physical channels
- Power weighting of physical channels
- Modulation and demodulation of physical channels
- Frequency and time synchronisation
- Radio characteristics measurements and indication to higher layers
- Multiple Input Multiple Output (MIMO) antenna processing

(Source:

[https://www.etsi.org/deliver/etsi_ts/136300_136399/136302/15.00.00_60/ts_136302v150000p.p](https://www.etsi.org/deliver/etsi_ts/136300_136399/136302/15.00.00_60/ts_136302v150000p.pdf)

[df](#))

4.1 Cell search

Cell search is the procedure by which a UE acquires time and frequency synchronization with a cell and detects the physical layer Cell ID of that cell. E-UTRA cell search supports a scalable overall transmission bandwidth corresponding to 6 resource blocks and upwards.

The following signals are transmitted in the downlink to facilitate cell search: the primary and secondary synchronization signals.

A UE may assume the antenna ports 0 – 3 and the antenna port for the primary/secondary synchronization signals of a serving cell are quasi co-located (as defined in [3]) with respect to Doppler shift and average delay.

(Source:

[https://www.etsi.org/deliver/etsi_ts/136200_136299/136213/14.02.00_60/ts_136213v140200p.p](https://www.etsi.org/deliver/etsi_ts/136200_136299/136213/14.02.00_60/ts_136213v140200p.pdf)

[df](#))

24. The methods practiced by Mofi's use of the accused products include wherein the synchronizing in the time domain comprises coarse time synchronizing and fine time

synchronizing. For example, the physical layer performs time and frequency synchronization on received frames using the cell search procedure. It uses primary and secondary synchronization signals for time and frequency synchronization. The time synchronization includes coarse and fine time synchronizations. The PSS and the SSS are and have been used for symbol timing and radio frame timing respectively providing coarse and fine timing synchronization.

The physical channels defined in the downlink are:

- the Physical Downlink Shared Channel (PDSCH),
- the Physical Multicast Channel (PMCH),
- the Physical Downlink Control Channel (PDCCH),
- the Relay Physical Downlink Control Channel (R-PDCCH),
- the Physical Broadcast Channel (PBCH),
- the Physical Control Format Indicator Channel (PCFICH)
- and the Physical Hybrid ARQ Indicator Channel (PHICH).

The physical channels defined in the uplink are:

- the Physical Random Access Channel (PRACH),
- the Physical Uplink Shared Channel (PUSCH),
- and the Physical Uplink Control Channel (PUCCH).

In addition, signals are defined as reference signals, primary and secondary synchronization signals.

The modulation schemes supported in the downlink and uplink are QPSK, 16QAM and 64QAM.

(Source:

https://www.etsi.org/deliver/etsi_ts/136200_136299/136201/10.00.00_60/ts_136201v10000p.pdf)

4.1 Cell search

Cell search is the procedure by which a UE acquires time and frequency synchronization with a cell and detects the physical layer Cell ID of that cell. E-UTRA cell search supports a scalable overall transmission bandwidth corresponding to 6 resource blocks and upwards.

The following signals are transmitted in the downlink to facilitate cell search: the primary and secondary synchronization signals.

A UE may assume the antenna ports 0 – 3 and the antenna port for the primary/secondary synchronization signals of a serving cell are quasi co-located (as defined in [3]) with respect to Doppler shift and average delay.

(Source:

https://www.etsi.org/deliver/etsi_ts/136200_136299/136213/14.02.00_60/ts_136213v140200p.pdf)

In time- and frequency-synchronous multi-carrier transmission the receiver at the base station needs to detect the start position of an OFDM symbol or frame and to estimate the channel state information from some known pilot symbols inserted in each OFDM symbol. If the coherence time of the channel exceeds an OFDM symbol, the channel estimation can estimate the time variation as well. This strategy, which will be considered in the following, simplifies a burst receiver.

(Source: Multi-Carrier and Spread Spectrum Systems: From OFDM and MC-CDMA to LTE and WiMAX, Fazel et. Al (2008))

4.2.4.2 Fine Symbol Timing

For fine time synchronization, several methods based on transmitted reference symbols can be used [14]. One straightforward solution applies the estimation of the channel impulse response. The received signal without noise $r(t) = s(t) \otimes h(t)$ is the convolution of the transmit signal $s(t)$ and the channel impulse response $h(t)$. In the frequency domain after FFT processing we obtain $R(f) = S(f)H(f)$. By transmitting special reference symbols (e.g. CAZAC sequences [63]), $S(f)$ is *a priori* known by the receiver. Hence,

(Source: Multi-Carrier and Spread Spectrum Systems: From OFDM and MC-CDMA to LTE and WiMAX, Fazel et. Al (2008))

If you go into a little bit further details, you would need a couple of additional steps as follows (step (1) and step (2)). To detect PSS and SSS, you need to get the data with a sequence of specific resource elements accurately. To accurately extract the data from a specific resource elements, you need to know the exact symbol boundary (starting sample and ending sample of an OFDM symbol). Once you detect the exact symbol boundary, you can detect the frequency offset (a kind of frequency error) to further compensate the signal. In some sense, these two steps are more difficult than PSS, SSS detection.

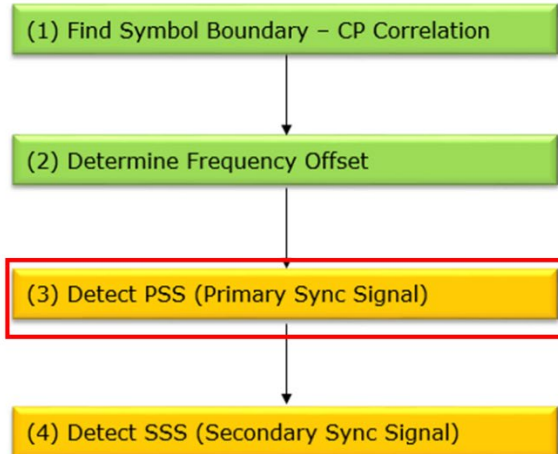

(Source: http://www.sharetechnote.com/html/BasicProcedure_LTE_TimeSync.html)

Determining Frame Synchronization and Cell Identification

The cell search involves two steps:

1. Perform running correlation with three possible PSS and detect a peak in any of the three correlators. The position of the peak provides frame timing with an uncertainty of five subframes, as the PSS is present in both subframe 0 and subframe 5.
2. Once a peak is detected, perform correlation with 31 possible SSS in subframes 0 and 5 to find one of 168 possible combinations of two SSS.

(Source: <https://www.mathworks.com/company/newsletters/articles/understanding-and-demodulating-lte-signals.html>)

15.1.1 DISCOVERY SIGNAL AND ASSOCIATED MEASUREMENTS

The *discovery reference signal* (DRS), although described as a new signal, actually consists of a combination already existing signals, namely

- synchronization signal (PSS and SSS) to assist in obtaining the cell identity and coarse frequency and time synchronization;
- cell-specific reference signals (CRS) to assist in obtaining fine frequency and time synchronization;
- CSI reference signals (optional) useful in determining the transmission point identity within the cell.

(Source: 4G, LTE-Advanced Pro and The Road to 5G, Dahlman et al. (2016))

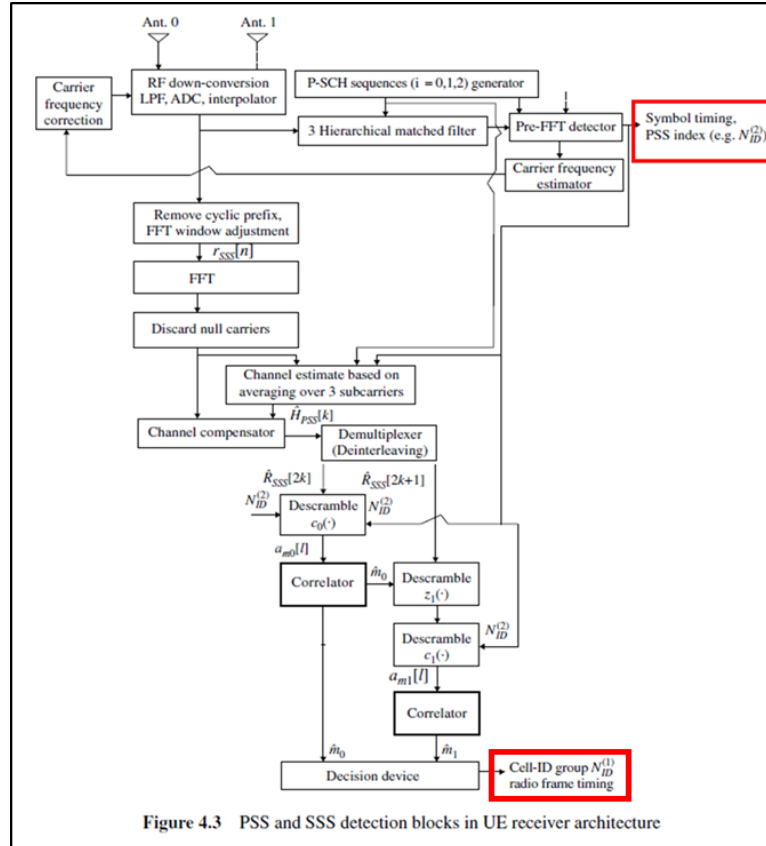

(Source: Mobile Terminal Receiver Design: LTE and LTE-Advanced, Das, Sajal Kumar

(2017))

Step1: Symbol Timing, Frequency Offset and Physical Layer ID Detection using PSS

In this stage, the symbol timing, frequency offset, and physical-layer ID are detected using PSS. As discussed above, the PSS occupies a bandwidth of 62×15 kHz around the

(Source: Mobile Terminal Receiver Design: LTE and LTE-Advanced, Das, Sajal Kumar

(2017))

Step-2: Radio Frame Timing and Cell Group ID Detection using SSS

Next, the radio-frame timing and cell group ID are detected using SSS in the frequency domain. As the SSS detection is generally performed in the frequency domain, FFT is

(Source: Mobile Terminal Receiver Design: LTE and LTE-Advanced, Das, Sajal Kumar (2017))

25. Mofi has had actual knowledge of the ‘782 Patent at least as of the date when it was notified of the filing of this action. By the time of trial, Mofi will have known and intended (since receiving such notice) that its continued actions would infringe and actively induce and contribute to the infringement of one or more claims of the ‘782 Patent.

26. Mofi has also indirectly and willfully infringed, and continues to indirectly and willfully infringe, the ‘782 Patent, as explained further below in the “Additional Allegations Regarding Infringement” section.

27. American Patents has been damaged as a result of the infringing conduct by Mofi alleged above. Thus, Mofi is liable to American Patents in an amount that adequately compensates it for such infringements, which, by law, cannot be less than a reasonable royalty, together with interest and costs as fixed by this Court under 35 U.S.C. § 284.

28. American Patents has neither made nor sold unmarked articles that practice the ‘782 Patent, and is entitled to collect pre-filing damages for the full period allowed by law for infringement of the ‘782 Patent.

COUNT II

INFRINGEMENT OF U.S. PATENT NO. 7,310,304

29. On December 18, 2007, United States Patent No. 7,310,304 (“the ‘304 Patent”) was duly and legally issued by the United States Patent and Trademark Office for an invention entitled “Estimating Channel Parameters in Multi-Input, Multi-Output (MIMO) Systems.”

30. American Patents is the owner of the ‘304 Patent, with all substantive rights in and to that patent, including the sole and exclusive right to prosecute this action and enforce the ‘304 Patent against infringers, and to collect damages for all relevant times.

31. Mofi made, had made, used, imported, provided, supplied, distributed, sold, and/or offered for sale products and/or systems including, for example, its MOFI4500-4GXeLTE-SIM8-VEHICLE-COMBO-V3, MOFI5500-5GXeLTE-EM7411-COMBO, and MOFI5500-5GXeLTE-EM9191-COMBO CAT families of products, that include LTE and/or 802.11n and above wireless capabilities (“accused products”):

TOLL FREE 1-888-499-0123 About Us | Contact | FAQ | Login | Cart / \$0.00

Mofi NETWORK SHOP ▾ SUPPORT SEARCH SITE Q



Product image showing the Mofi 4500-4G LTE router with its four antennas. Below the main image are four smaller thumbnails: a top-down view, a side view, a close-up of the power supply and cables, and a close-up of the antenna connectors.

HOME / ROUTERS / 4G/LTE (NO 5G) < >

MOFI4500-4GXeLTE-SIM8-VEHICLE-COMBO V3

—

\$354.99

QUANTITY	PRICE
1	\$354.99
2 - 4	\$349.99
5 - 9	\$344.99
10+	\$339.99

- 1 + ADD TO CART

PayPal

(Source: <https://mofinetwork.com/product/mofi4500-4gxelte-sim8-vehicle-combo-v3/>)

TOLL FREE 1-888-499-0123

About Us | Contact | FAQ | Login | Cart / \$0.00



SHOP ▾ SUPPORT

SEARCH SITE



HOME / ROUTERS / 4G/LTE (NO 5G)

MOFI5500-5GXeLTE-EM7411-COMBO (IN STOCK)

\$399.99

MOFI5500-5GXeLTE-EM7411-COMBO

(Source: <https://mofinetwork.com/product/mofi5500-5gxelte-em7411-combo/>)

TOLL FREE 1-888-499-0123 About Us Contact FAQ Login Cart / \$0.00

MoFi NETWORK SHOP SUPPORT SEARCH SITE



HOME / ROUTERS / 4G/LTE/5G

MOFI5500-5GXeLTE-EM9191-COMBO CAT20 LTE + 5G ROUTER (IN STOCK)

\$699.99

MOFI5500-5GXeLTE-EM9191-COMBO

(Source: <https://mofinetwork.com/product/mofi5500-5gxelte-em9191-combo-cat20-lte-5g-router-pre-order-expected-to-ship-on-july-06-2021/>)

Internal Module Specs:

LTE Category 7: 300Mbps DL, 150Mbps UL (note the max this model can handle is up to 100mb/s)

HSPA+: 42Mbps DL, 5.76 UL

TD-HSDPA/HSUPA: 2.8Mbps DL, 2.2Mbps UL

EDGE: Multi Slot Class 12 236.8 kbps DL & UL

GPRS: Multi Slot Class 10 85.6 kbps DL & UL

Frequency Bands:

B2, B4, B5, B7, B12, B13, B14, B17, B25, B26, B41, B42, B43, B48, B66, B71

(Source: <https://mofinetwork.com/product/mofi4500-4gxelte-sim8-vehicle-combo-v3/>)

Internal Module Specs:

NOTE THIS IS NOT A 5G ROUTER

This item is made to work in North America but may also work in many other countries around the world.

For North America, no need to check the bands but if using outside Canada/USA, check the band support for compatibility.

LTE Category 7: 300Mbps DL, 150Mbps UL

Supports up to 2 x Carrier Aggregation

HSPA+: 42Mbps DL, 5.76 UL

TD-HSDPA/HSUPA: 2.8Mbps DL, 2.2Mbps UL

EDGE: Multi Slot Class 12 236.8 kbps DL & UL

GPRS: Multi Slot Class 10 85.6 kbps DL & UL

Frequency Bands:

B2, B4, B5, B7, B12, B13, B14, B17, B25, B26, B41, B42, B43, B48, B66, B71

(Source: <https://mofinetwork.com/product/mofi5500-5gxelte-em7411-combo/>)

Internal Module Specs:

This item is made to work in anywhere on the planet!

5G LTE Category 20: 2000Mbps (4.5Gbps) DL, 660Mbps UL

5 x Carrier Aggregations

HSPA+: 42Mbps DL, 5.76 UL

TD-HSDPA/HSUPA: 2.8Mbps DL, 2.2Mbps UL

EDGE: Multi Slot Class 12 236.8 kbps DL & UL

GPRS: Multi Slot Class 10 85.6 kbps DL & UL

Frequency Bands:

4G/LTE Bands: B1, B2, B3, B4, B5, B7, B8, B9, B12, B13, B14, B17, B18, B19, B20, B21, B25, B26, B28, B29, B30, B32, B34, B38, B39, B40, B41, B42, B43, B46, B48, B66, B71

5G Bands: For 5G: N1, N2, N3, N5, N7, N8, N12, N20, N25, N28, N38, N40, N41, N48, N66, N71, N77, N78, N79

If you want to see if the router is compatible with your provider on the signal side, see what 4G/LTE/5G bands your provider will use and compare to what is available. It will be very hard to find a provider that is not compatible with this product.

(Source: <https://mofinetwork.com/product/mofi5500-5gxelte-em9191-combo-cat20-lte-5g-router-pre-order-expected-to-ship-on-july-06-2021/>)

User equipment Category	Max. LI datarate Downlink (Mbit/s)	Max. number of DL MIMO layers	Max. LI datarate Uplink (Mbit/s)	3GPP Release
NB-I	0.68	1	1.0	Rel 13
M1	1.0	1	1.0	
0	1.0	1	1.0	Rel 12
1	10.3	1	5.2	Rel 8
2	51.0	2	25.5	
3	102.0	2	51.0	
4	150.8	2	51.0	
5	299.6	4	75.4	
6	301.5	2 or 4	51.0	Rel 10
7	301.5	2 or 4	102.0	
8	2,998.6	8	1,497.8	
9	452.2	2 or 4	51.0	Rel 11
10	452.2	2 or 4	102.0	
11	603.0	2 or 4	51.0	
12	603.0	2 or 4	102.0	

(Source: <https://www.cablefree.net/wirelesstechnology/4glte/lte-ue-category-class-definitions>)

32. By doing so, Mofi has directly infringed (literally and/or under the doctrine of equivalents) at least Claim 1 of the '304 Patent. Mofi's infringement in this regard is ongoing.

33. Mofi has infringed the '304 Patent by making, having made, using, importing, providing, supplying, distributing, selling or offering for sale products including an Orthogonal Frequency Division Multiplexing (OFDM) transmitter. For example, the accused products support LTE standards with MIMO technology.

Internal Module Specs:

LTE Category 7: 300Mbps DL, 150Mbps UL (note the max this model can handle is up to 100mb/s)
HSPA+: 42Mbps DL, 5.76 UL
TD-HSDPA/HSUPA: 2.8Mbps DL, 2.2Mbps UL
EDGE: Multi Slot Class 12 236.8 kbps DL & UL
GPRS: Multi Slot Class 10 85.6 kbps DL & UL
Frequency Bands:
B2, B4, B5, B7, B12, B13, B14, B17, B25, B26, B41, B42, B43, B48, B66, B71

(Source: <https://mofinetwork.com/product/mofi4500-4gxelte-sim8-vehicle-combo-v3/>)

Internal Module Specs:

NOTE THIS IS NOT A 5G ROUTER

This item is made to work in North America but may also work in many other countries around the world.

For North America, no need to check the bands but if using outside Canada/USA, check the band support for compatibility.

LTE Category 7: 300Mbps DL, 150Mbps UL

Supports up to 2 x Carrier Aggregation

HSPA+: 42Mbps DL, 5.76 UL

TD-HSDPA/HSUPA: 2.8Mbps DL, 2.2Mbps UL

EDGE: Multi Slot Class 12 236.8 kbps DL & UL

GPRS: Multi Slot Class 10 85.6 kbps DL & UL

Frequency Bands:

B2, B4, B5, B7, B12, B13, B14, B17, B25, B26, B41, B42, B43, B48, B66, B71

(Source: <https://mofinetwork.com/product/mofi5500-5gxelte-em7411-combo/>)

Internal Module Specs:

This item is made to work in anywhere on the planet!

5G LTE Category 20: 2000Mbps (4.5Gbps) DL, 660Mbps UL

5 x Carrier Aggregations

HSPA+: 42Mbps DL, 5.76 UL

TD-HSDPA/HSUPA: 2.8Mbps DL, 2.2Mbps UL

EDGE: Multi Slot Class 12 236.8 kbps DL & UL

GPRS: Multi Slot Class 10 85.6 kbps DL & UL

Frequency Bands:

4G/LTE Bands: B1, B2, B3, B4, B5, B7, B8, B9, B12, B13, B14, B17, B18, B19, B20, B21, B25, B26, B28, B29, B30, B32, B34, B38, B39, B40, B41, B42, B43, B46, B48, B66, B71

5G Bands: For 5G: N1, N2, N3, N5, N7, N8, N12, N20, N25, N28, N38, N40, N41, N48, N66, N71, N77, N78, N79

If you want to see if the router is compatible with your provider on the signal side, see what 4G/LTE/5G bands your provider will use and compare to what is available. It will be very hard to find a provider that is not compatible with this product.

(Source: <https://mofinetwork.com/product/mofi5500-5gxelte-em9191-combo-cat20-lte-5g-router-pre-order-expected-to-ship-on-july-06-2021/>)

User equipment Category	Max. L1 datarate Downlink (Mbit/s)	Max. number of DL MIMO layers	Max. L1 datarate Uplink (Mbit/s)	3GPP Release
NB-I	0.68	1	1.0	Rel 13
MI	1.0	1	1.0	
0	1.0	1	1.0	Rel 12
1	10.3	1	5.2	Rel 8
2	51.0	2	25.5	
3	102.0	2	51.0	
4	150.8	2	51.0	
5	299.6	4	75.4	
6	301.5	2 or 4	51.0	Rel 10
7	301.5	2 or 4	102.0	
8	2,998.6	8	1,497.8	
9	452.2	2 or 4	51.0	Rel 11
10	452.2	2 or 4	102.0	
11	603.0	2 or 4	51.0	
12	603.0	2 or 4	102.0	

(Source: <https://www.cablefree.net/wirelesstechnology/4glte/lte-ue-category-class-definitions>)

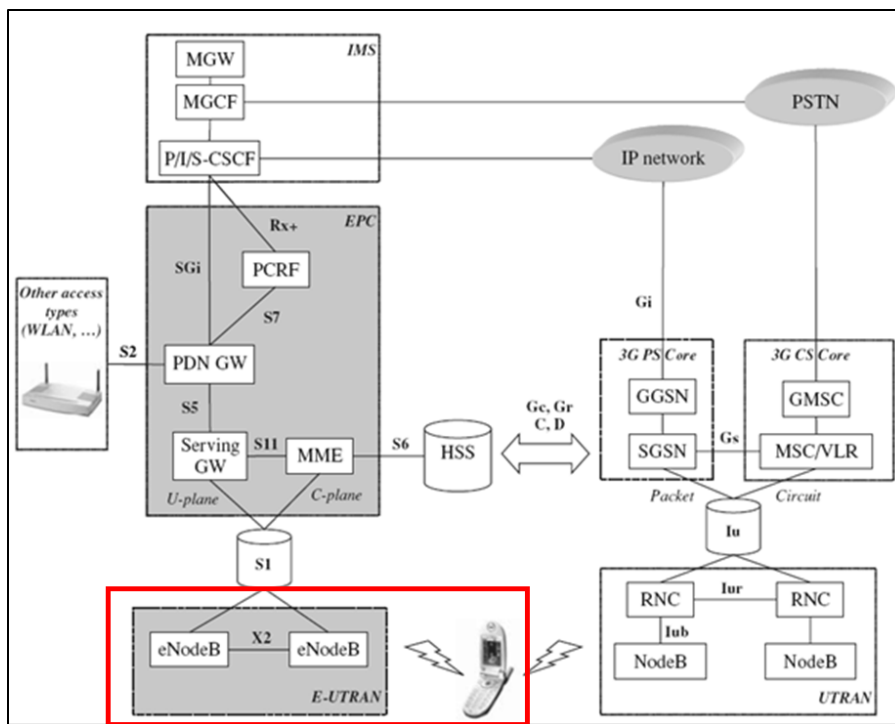

(Source: <https://sites.google.com/site/lteencyclopedia/lte-network-infrastructure-and-elements>)

34. The accused products include an encoder configured to process data to be transmitted within an OFDM system, the encoder further configured to separate the data onto one or more transmit diversity branches (TDBs). Alternatively, on request from an accused product, an LTE base station includes a transmitter in an OFDM system with an encoder configured to process data to be transmitted within an OFDM system, the encoder further configured to separate the data onto one or more transmit diversity branches (TDBs). For example, according to the LTE standards, the physical layer performs FEC encoding on the transmitting data. Hence, there is an encoder block at the transmitter end; additionally, transmit diversity is performed at the transmitter end. The encoders output the data onto multiple transmit chains (i.e. transmit diversity branches) for further processing.

4.1.2 Service provided to higher layers

The physical layer offers data transport services to higher layers. The access to these services is through the use of a transport channel via the MAC sub-layer. The physical layer is expected to perform the following functions in order to provide the data transport service:

- Error detection on the transport channel and indication to higher layers
- FEC encoding/decoding of the transport channel
- Hybrid ARQ soft-combining
- Rate matching of the coded transport channel to physical channels
- Mapping of the coded transport channel onto physical channels
- Power weighting of physical channels
- Modulation and demodulation of physical channels
- Frequency and time synchronisation
- Radio characteristics measurements and indication to higher layers
- Multiple Input Multiple Output (MIMO) antenna processing
- Transmit Diversity (TX diversity)
- Beamforming
- RF processing. (Note: RF processing aspects are specified in the TS 36.100 series)

(Source:

https://www.etsi.org/deliver/etsi_ts/136200_136299/136201/10.00.00_60/ts_136201v100000p.pdf)

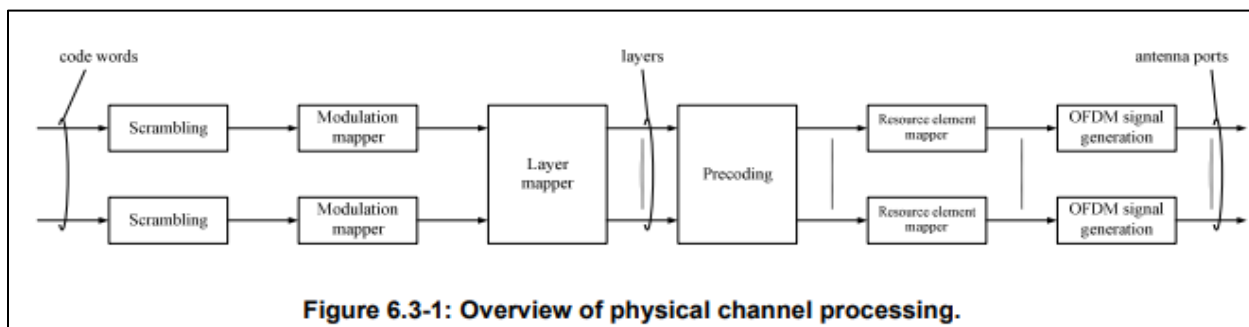

Figure 6.3-1: Overview of physical channel processing.

(Source:

https://www.etsi.org/deliver/etsi_ts/136200_136299/136211/08.06.00_60/ts_136211v080600p.pdf)

35. The accused products include one or more OFDM modulators, each OFDM modulator connected to a respective TDB, each OFDM modulator configured to produce a frame

including a plurality of data symbols, a training structure, and cyclic prefixes inserted among the data symbols. For example, the physical layer performs the modulation and demodulation of the physical channels. Further, it uses OFDM in the downlink physical channel. Hence, there would be OFDM modulators for modulating the data signals. The physical layer transmits frames of data on the downlink that include cyclic prefixes, training symbols and other data groups.

The physical layer offers data transport services to higher layers. The access to these services is through the use of a transport channel via the MAC sub-layer. The physical layer is expected to perform the following functions in order to provide the data transport service:

- Error detection on the transport channel and indication to higher layers
- FEC encoding/decoding of the transport channel
- Hybrid ARQ soft-combining
- Rate matching of the coded transport channel to physical channels
- Mapping of the coded transport channel onto physical channels
- Power weighting of physical channels
- Modulation and demodulation of physical channels
- Frequency and time synchronisation
- Radio characteristics measurements and indication to higher layers

(Source:

https://www.etsi.org/deliver/etsi_ts/136200_136299/136201/10.00.00_60/ts_136201v10000p.pdf)

4.2.1 Multiple Access

The multiple access scheme for the LTE physical layer is based on Orthogonal Frequency Division Multiplexing (OFDM) with a cyclic prefix (CP) in the downlink, and on Single-Carrier Frequency Division Multiple Access (SC-FDMA) with a cyclic prefix in the uplink. To support transmission in paired and unpaired spectrum, two duplex modes

(Source:

https://www.etsi.org/deliver/etsi_ts/136200_136299/136201/10.00.00_60/ts_136201v10000p.pdf)

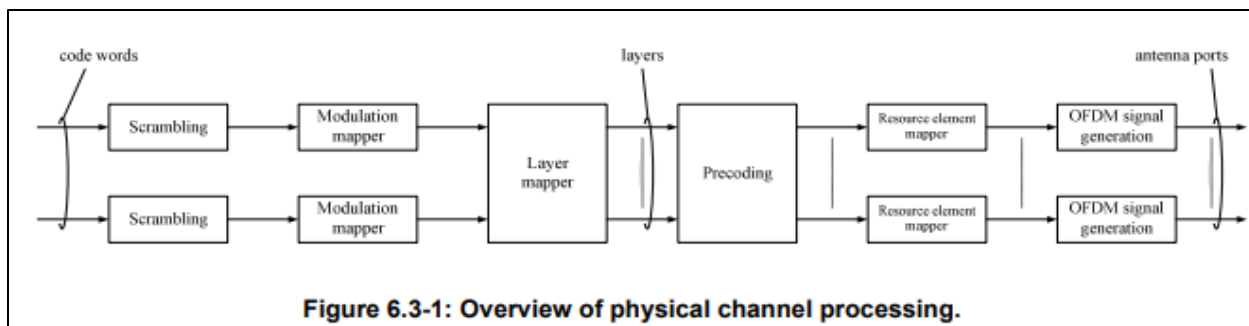
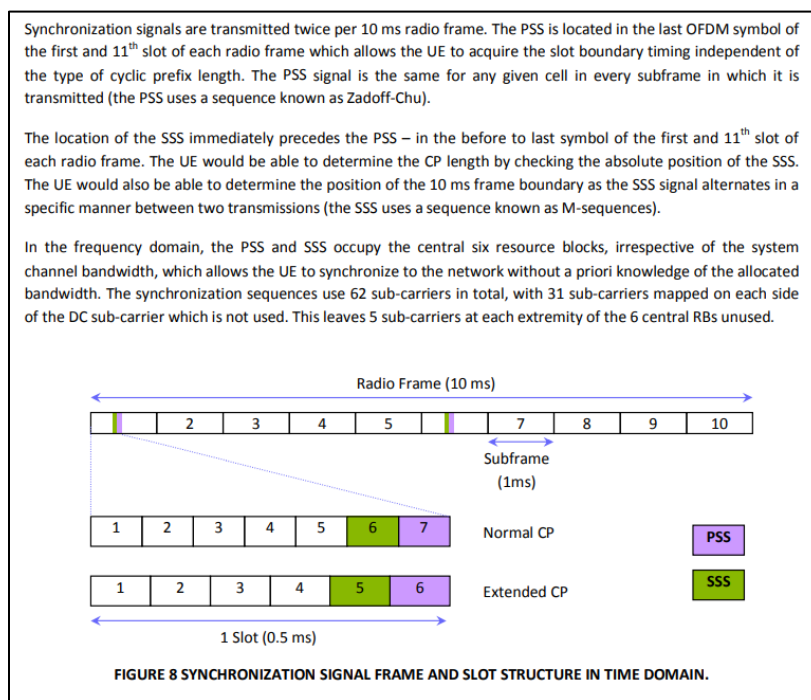

Figure 6.3-1: Overview of physical channel processing.

(Source:

https://www.etsi.org/deliver/etsi_ts/136200_136299/136211/08.06.00_60/ts_136211v080600p.pdf)



(Source: <https://home.zhaw.ch/kunr/NTM1/literatur/LTE%20in%20a%20Nutshell%20-%20Physical%20Layer.pdf>)

36. The accused products include one or more transmitting antennas in communication with the one or more OFDM modulators, respectively, each transmitting antenna configured to transmit the respective frame over a channel. Alternatively, on request from an accused product, an LTE base station includes one or more transmitting antennas in

communication with the one or more OFDM modulators, respectively, each transmitting antenna configured to transmit the respective frame over a channel. The transmitting antennas in the base station are connected to the OFDM modulators to get the OFDM frames for further transmission.

“Synchronization” refers to the technique applied to ensure the radios in the target LTE basestation are operating within the performance parameters defined by the appropriate 3rd Generation Partners Project (3GPP) standard. Synchronization is achieved by delivering a specifically formatted clock signal or signals to the basestation’s radio circuitry. These signals in turn are used to generate the modulation method’s RF air interface frequency/phase components.

The RF or air interface requirements of LTE are determined by the 3GPP, a collaboration between groups of telecommunications associations, known as the Organizational Partners. The 3GPP’s standardization encompasses radio, core network, and service architecture.

(Source: <https://www.electronicdesign.com/communications/lte-requires-synchronization-and-standards-support>)

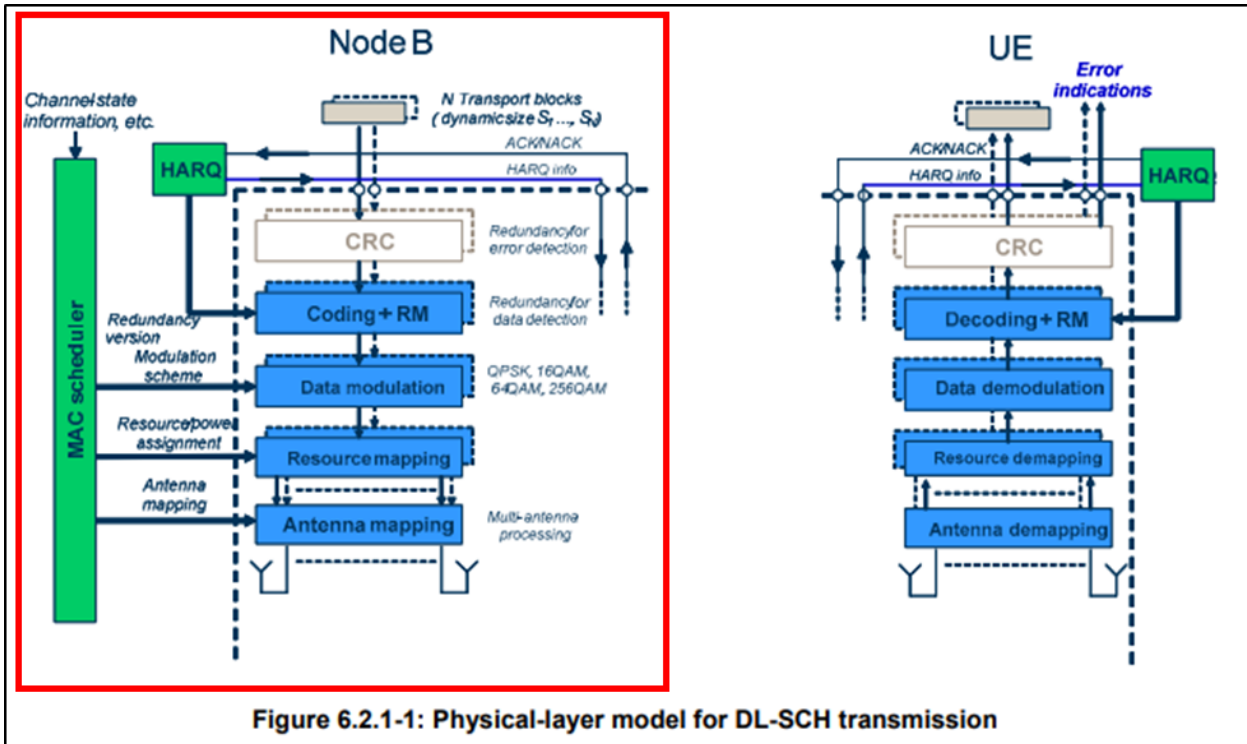

(Source :

[https://www.etsi.org/deliver/etsi_ts/136300_136399/136302/15.00.00_60/ts_136302v150000p.p](https://www.etsi.org/deliver/etsi_ts/136300_136399/136302/15.00.00_60/ts_136302v150000p.pdf)

[df](#))

6.7 Physical control format indicator channel

The physical control format indicator channel carries information about the number of OFDM symbols used for transmission of PDCCHs in a subframe. The set of OFDM symbols possible to use for PDCCH in a subframe is given by Table 6.7-1.

(Source:

[https://www.etsi.org/deliver/etsi_ts/136200_136299/136211/11.05.00_60/ts_136211v110500p.p](https://www.etsi.org/deliver/etsi_ts/136200_136299/136211/11.05.00_60/ts_136211v110500p.pdf)

[df](#))

37. The accused products include wherein the training structure of each frame includes a predetermined signal transmission matrix at a respective sub-channel, each training structure adjusted to have a substantially constant amplitude in a time domain, and the cyclic prefixes are further inserted within the training symbol, and wherein the cyclic prefixes within the training symbol are longer than the cyclic prefixes among the data symbols, thereby countering an extended channel impulse response and improving synchronization performance. Alternatively, on request from an accused product, an LTE base station includes a transmitter in an Orthogonal Frequency Division Multiplexing (OFDM) system, the transmitter comprising one or more OFDM modulators configured to produce a frame including a plurality of data symbols, a training structure, and cyclic prefixes inserted among the data symbols; wherein the training structure of each frame includes a predetermined signal transmission matrix at a respective sub-channel, each training structure adjusted to have a substantially constant amplitude in a time domain, and the cyclic prefixes are further inserted within the training symbol, and wherein the cyclic prefixes within the training symbol are longer than the cyclic prefixes among the data

symbols, thereby countering an extended channel impulse response and improving synchronization performance. For example, the physical layer performs precoding on both the downlink by generating a precoding matrix (i.e. signal transmission matrix) which is transmitted along with the data frames. Cyclic prefixes are added to the transmitting frames to help in frame synchronization at the receiver end. The evidence shows that a cell-specific reference signal acting as the training sequence are and have been used for channel estimation and are present in the first symbol of the slots in the frame. Also, the evidence shows that the cyclic prefix in the first symbol is longer than the cyclic prefix in the other data symbols. Thus, the cyclic prefix in the training structure reference signals are longer than the cyclic prefixes in the other data symbols. The primary synchronization signals and the cell specific reference signals are generated using Zadoff-Chu sequences which have a constant amplitude.

The scope of this specification is to establish the characteristics of the Layer-1 physical channels, generation of physical layer signals and modulation, and to specify:

- Definition of the uplink and downlink physical channels;
- The structure of the physical channels, frame format, physical resource elements, etc.;
- Modulation mapping (BPSK, QPSK, etc);
- Physical shared channel in uplink and downlink;
- Reference signal in uplink and downlink;
- Random access channel;
- Primary and secondary synchronization signals;
- OFDM signal generation in downlink;
- SC-FDMA signal generation in uplink;
- Scrambling, modulation and up conversion;
- Uplink-downlink timing relation;
- Layer mapping and precoding in downlink and uplink.

(Source:

https://www.etsi.org/deliver/etsi_ts/136200_136299/136201/10.00.00_60/ts_136201v100000p.p

[df](#))

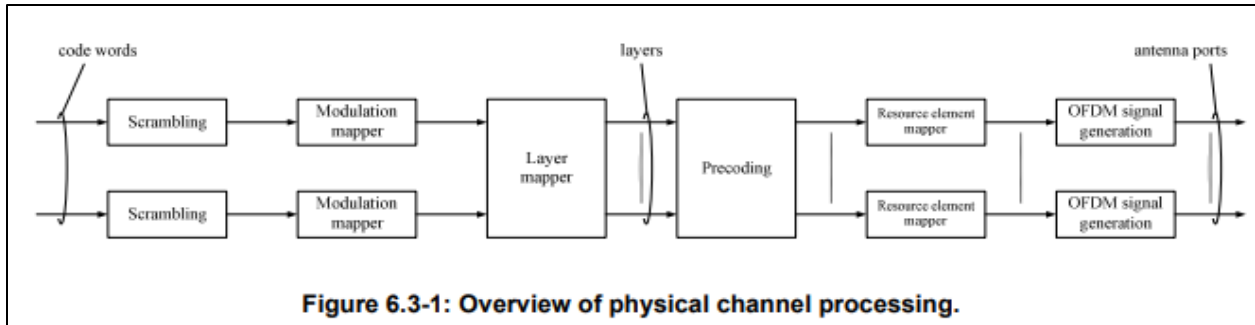

(Source:

https://www.etsi.org/deliver/etsi_ts/136200_136299/136211/08.06.00_60/ts_136211v080600p.p

df)

6.3.4 Precoding

The precoder takes as input a block of vectors $x(i) = [x^{(0)}(i) \ \dots \ x^{(v-1)}(i)]^T$, $i = 0, 1, \dots, M_{\text{symp}}^{\text{layer}} - 1$ from the layer mapping and generates a block of vectors $y(i) = [\dots \ y^{(p)}(i) \ \dots]^T$, $i = 0, 1, \dots, M_{\text{symp}}^{\text{ap}} - 1$ to be mapped onto resources on each of the antenna ports, where $y^{(p)}(i)$ represents the signal for antenna port p .

(Source:

https://www.etsi.org/deliver/etsi_ts/136200_136299/136211/08.06.00_60/ts_136211v080600p.p

df)

6.3.4.2.1 Precoding without CDD

Without cyclic delay diversity (CDD), precoding for spatial multiplexing is defined by

$$\begin{bmatrix} y^{(0)}(i) \\ \vdots \\ y^{(P-1)}(i) \end{bmatrix} = W(i) \begin{bmatrix} x^{(0)}(i) \\ \vdots \\ x^{(v-1)}(i) \end{bmatrix}$$

where the precoding matrix $W(i)$ is of size $P \times v$ and $i = 0, 1, \dots, M_{\text{symp}}^{\text{ap}} - 1$, $M_{\text{symp}}^{\text{ap}} = M_{\text{symp}}^{\text{layer}}$.

For spatial multiplexing, the values of $W(i)$ shall be selected among the precoder elements in the codebook configured in the eNodeB and the UE. The eNodeB can further confine the precoder selection in the UE to a subset of the elements in the codebook using codebook subset restrictions. The configured codebook shall be selected from Table 6.3.4.2.3-1 or 6.3.4.2.3-2.

(Source:

https://www.etsi.org/deliver/etsi_ts/136200_136299/136211/08.06.00_60/ts_136211v080600p.p

df)

6.3.4.2.2 Precoding for large delay CDD

For large-delay CDD, precoding for spatial multiplexing is defined by

$$\begin{bmatrix} y^{(0)}(i) \\ \vdots \\ y^{(P-1)}(i) \end{bmatrix} = W(i)D(i)U \begin{bmatrix} x^{(0)}(i) \\ \vdots \\ x^{(v-1)}(i) \end{bmatrix}$$

where the precoding matrix $W(i)$ is of size $P \times v$ and $i = 0, 1, \dots, M_{\text{symb}}^{\text{ap}} - 1$, $M_{\text{symb}}^{\text{ap}} = M_{\text{symb}}^{\text{layer}}$. The diagonal size- $v \times v$ matrix $D(i)$ supporting cyclic delay diversity and the size- $v \times v$ matrix U are both given by Table 6.3.4.2.2-1 for different numbers of layers v .

The values of the precoding matrix $W(i)$ shall be selected among the precoder elements in the codebook configured in the eNodeB and the UE. The eNodeB can further confine the precoder selection in the UE to a subset of the elements in the codebook using codebook subset restriction. The configured codebook shall be selected from Table 6.3.4.2.3-1 or 6.3.4.2.3-2.

(Source:

https://www.etsi.org/deliver/etsi_ts/136200_136299/136211/08.06.00_60/ts_136211v080600p.p

df)

The spatial correlation matrix for the complete system can be calculated using equation (1) above and forming the individual spatial correlation matrices at the eNB and the UE. For example, given a 2x2 MIMO system, assume the factors α and β represent the correlation coefficients, calculated using (1), for the eNB and UE antenna pairs, respectively. The correlation matrices for eNB and the UE are represented as

$$R_{\text{BS}} = \begin{pmatrix} 1 & \alpha \\ \alpha^* & 1 \end{pmatrix}. \quad (2)$$

$$R_{\text{US}} = \begin{pmatrix} 1 & \beta \\ \beta^* & 1 \end{pmatrix}. \quad (3)$$

The system spatial correlation matrix for the downlink channel can be calculated using the Kronecker product

$$R_{\text{S}} = R_{\text{BS}} \otimes R_{\text{US}}, \quad (4)$$

$$R_{\text{S}} = \begin{pmatrix} 1 & \beta & \alpha & \alpha\beta \\ \beta^* & 1 & \alpha\beta^* & \alpha \\ \alpha^* & \alpha^*\beta & 1 & \beta \\ \alpha^*\beta^* & \alpha^* & \beta^* & 1 \end{pmatrix}. \quad (5)$$

These expressions are needed to determine the parameters for the user interface of a fading emulator.

(Source: LTE and the Evolution to 4G Wireless: Design and Measurement Challenges, Wiley (2013))

The useful symbol time is $T_u = 2048 \cdot T_s \approx 66.7 \mu\text{s}$. For the normal mode, the first symbol has a cyclic prefix of length $T_{CP} = 160 \cdot T_s \approx 5.2 \mu\text{s}$. The remaining six symbols have a cyclic prefix of length $T_{CP} = 144 \cdot T_s \approx 4.7 \mu\text{s}$. The reason for different CP length of the first symbol is to make the overall slot length in terms of time units divisible by 15360. For the extended mode, the cyclic prefix is $T_{CP-e} = 512 \cdot T_s \approx 16.7 \mu\text{s}$. The CP is longer than the typical delay spread of a few microseconds typically encountered in practice as shown in Figure 4. The normal cyclic prefix is used in urban cells and high data rate applications while the extended cyclic prefix is used in special cases like multi-cell broadcast and in very large cells (e.g. rural areas, low data rate applications).

(Source: <https://home.zhaw.ch/kunr/NTM1/literatur/LTE%20in%20a%20Nutshell%20-%20Physical%20Layer.pdf>)

According to Chapter 4, a subcarrier spacing $\Delta f = 15 \text{ kHz}$ corresponds to a useful symbol time $T_u = 1/\Delta f \approx 66.7 \mu\text{s}$ ($2048 \cdot T_s$). The overall OFDM symbol time is then the sum of the useful symbol time and the cyclic-prefix length T_{CP} . As illustrated in Figure 16.5, LTE defines two cyclic-prefix lengths, the normal cyclic prefix and an *extended* cyclic prefix, corresponding to seven and six OFDM symbols per slot, respectively. The exact cyclic-prefix lengths, expressed in the basic time unit T_s , are given in Figure 16.5. It should be noted that, in case of the normal cyclic prefix, the cyclic-prefix length for the first OFDM symbol of a slot is somewhat larger, compared to the remaining OFDM symbols. The reason for this is simply to fill the entire 0.5 ms slot as the number of time units T_s per slot (15360) is not dividable by seven.

(Source: 3G Evolution: HSPA and LTE for Mobile Broadband, Dahlman, et al. (2010))

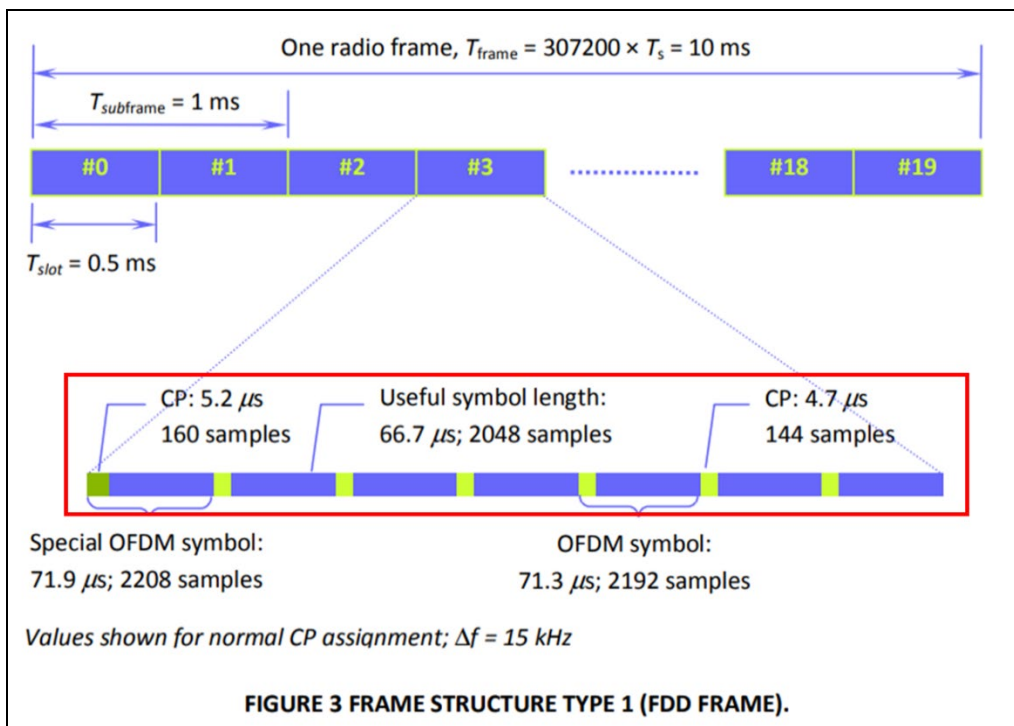

(Source: <https://home.zhaw.ch/kunr/NTM1/literatur/LTE%20in%20a%20Nutshell%20-%20Physical%20Layer.pdf>)

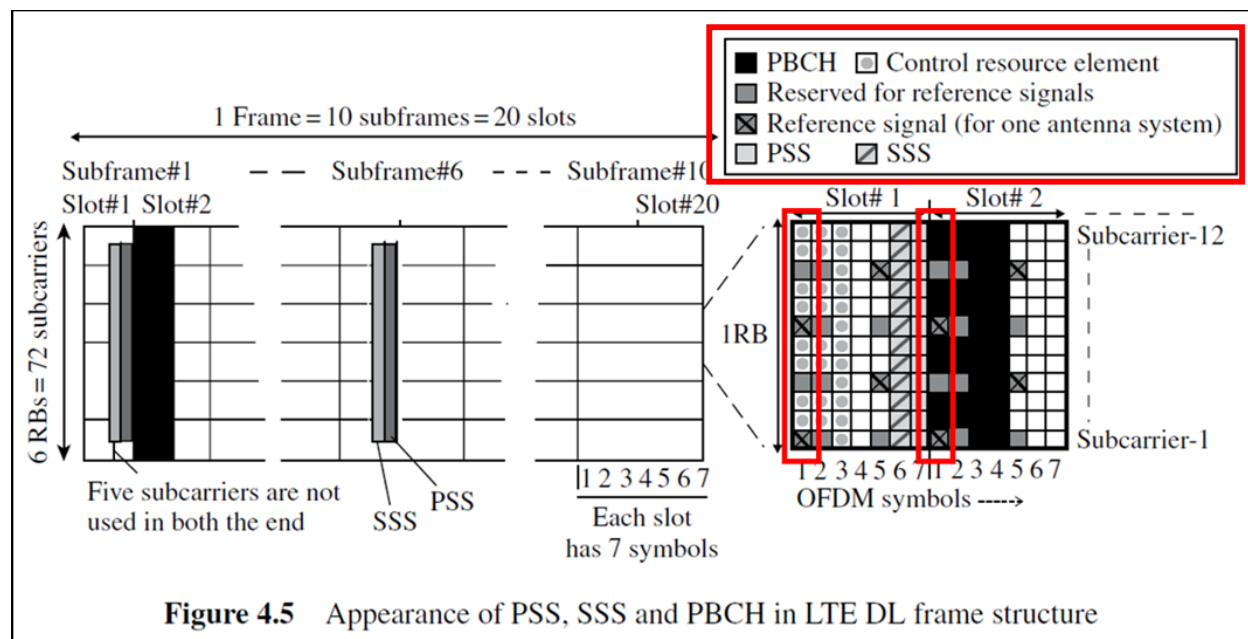

(Source: Mobile Terminal Receiver Design: LTE and LTE-Advanced, Das, Sajal Kumar (2017))

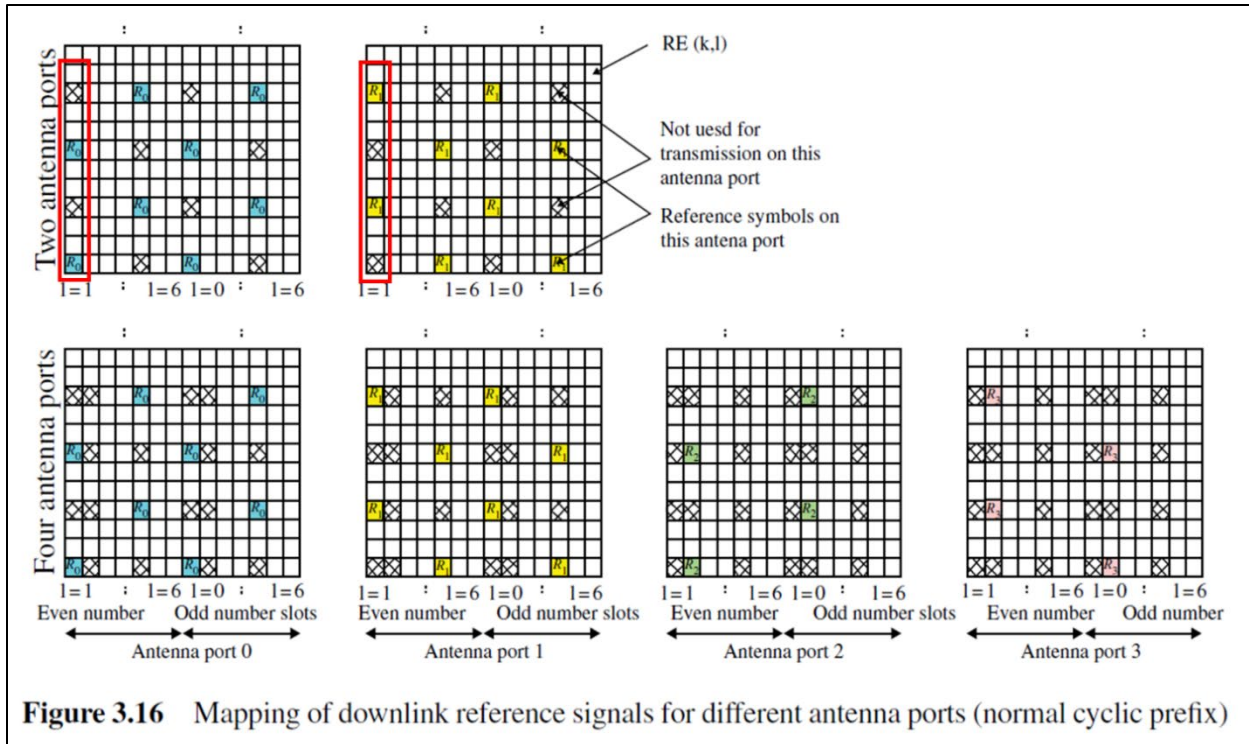

(Source: Mobile Terminal Receiver Design: LTE and LTE-Advanced, Das, Sajal Kumar (2017))

6.11.1 Primary synchronization signal

6.11.1.1 Sequence generation

The sequence $d(n)$ used for the primary synchronization signal is generated from a frequency-domain Zadoff-Chu sequence according to

$$d_u(n) = \begin{cases} e^{-j\frac{u(n+1)^2}{63}} & n = 0,1,\dots,30 \\ e^{-j\frac{u(n+1)(n+2)}{63}} & n = 31,32,\dots,61 \end{cases}$$

where the Zadoff-Chu root sequence index u is given by Table 6.11.1.1-1.

(Source:

https://www.etsi.org/deliver/etsi_ts/136200_136299/136211/08.06.00_60/ts_136211v080600p.pdf)

Zadoff chu sequence properties:

-It has constant amplitude.

-It has zero circular auto correlation.

-It has flat frequency domain response.

-circular cross correlation between two zadoff chu sequence is low.

-It has constant amplitude provided, L is a prime number.

LTE physical signals/channels where Zadoff chu is used

P-SS: Primary synchronization signal, Zadoff chu sequence is used for this signal.

RS: Reference Signal, used both in uplink and downlink, Zadoff chu sequence is used.

PUCCH: Physical Uplink Control Channel, Zadoff chu sequence is used.

(Source: <http://www.rfwireless-world.com/Terminology/Zadoff-chu-sequence-LTE.html>)

38. Mofi has had actual knowledge of the ‘304 Patent at least as of the date when it was notified of the filing of this action. By the time of trial, Mofi will have known and intended (since receiving such notice) that its continued actions would infringe and actively induce and contribute to the infringement of one or more claims of the ‘304 Patent.

39. Mofi has also indirectly and willfully infringed, and continues to indirectly and willfully infringe, the ‘304 Patent, as explained further below in the “Additional Allegations Regarding Infringement” section.

40. American Patents has been damaged as a result of the infringing conduct by Mofi alleged above. Thus, Mofi is liable to American Patents in an amount that adequately compensates it for such infringements, which, by law, cannot be less than a reasonable royalty, together with interest and costs as fixed by this Court under 35 U.S.C. § 284.

41. American Patents has neither made nor sold unmarked articles that practice the ‘304 Patent, and is entitled to collect pre-filing damages for the full period allowed by law for infringement of the ‘304 Patent.

COUNT III

INFRINGEMENT OF U.S. PATENT NO. 7,706,458

42. On April 27, 2010, United States Patent No. 7,706,458 (“the ‘458 Patent”) was duly and legally issued by the United States Patent and Trademark Office for an invention entitled “Time And Frequency Synchronization In Multi-Input, Multi-Output (MIMO) Systems.”





43. American Patents is the owner of the ‘458 Patent, with all substantive rights in and to that patent, including the sole and exclusive right to prosecute this action and enforce the ‘458 Patent against infringers, and to collect damages for all relevant times.

44. Mofi made, had made, used, imported, provided, supplied, distributed, sold, and/or offered for sale products and/or systems including, for example, its MOFI4500-4GXeLTE-SIM8-VEHICLE-COMBO-V3, MOFI5500-5GXeLTE-EM7411-COMBO, and MOFI5500-5GXeLTE-EM9191-COMBO CAT families of products, that include LTE and/or 802.11n and above wireless capabilities (“accused products”):

TOLL FREE 1-888-499-0123 About Us | Contact | FAQ | Login | Cart / \$0.00

Mofi NETWORK SHOP ▾ SUPPORT SEARCH SITE Q





HOME / ROUTERS / 4G/LTE (NO 5G)

MOFI4500-4GXeLTE-SIM8-VEHICLE-COMBO V3

\$354.99

QUANTITY	PRICE
1	\$354.99
2 - 4	\$349.99
5 - 9	\$344.99
10+	\$339.99

-1+ADD TO CART

PayPal

(Source: <https://mofinetwork.com/product/mofi4500-4gxelte-sim8-vehicle-combo-v3/>)

TOLL FREE 1-888-499-0123

About Us | Contact | FAQ | Login | Cart / \$0.00



SHOP ▾ SUPPORT

SEARCH SITE



HOME / ROUTERS / 4G/LTE (NO 5G)

MOFI5500-5GXeLTE-EM7411-COMBO (IN STOCK)

\$399.99

MOFI5500-5GXeLTE-EM7411-COMBO

(Source: <https://mofinetwork.com/product/mofi5500-5gxelte-em7411-combo/>)

TOLL FREE 1-888-499-0123 About Us Contact FAQ Login Cart / \$0.00

MoFi NETWORK SHOP SUPPORT SEARCH SITE



HOME / ROUTERS / 4G/LTE/5G

MOFI5500-5GXeLTE-EM9191-COMBO CAT20 LTE + 5G ROUTER (IN STOCK)

\$699.99

MOFI5500-5GXeLTE-EM9191-COMBO

The image shows a black MoFi 5500-5GXeLTE-EM9191-Combo Cat20 LTE + 5G Router. It is a rugged, rectangular device with several external antennas protruding from the top and sides. The front panel features a small display screen and several indicator lights. The MoFi logo is visible on the top left of the device. Below the main image are four smaller thumbnail images showing different views of the router: a front view, a side view, a top view, and a view of the router in a protective carrying case.

(Source: <https://mofinetwork.com/product/mofi5500-5gxelte-em9191-combo-cat20-lte-5g-router-pre-order-expected-to-ship-on-july-06-2021/>)

Internal Module Specs:

LTE Category 7: 300Mbps DL, 150Mbps UL (note the max this model can handle is up to 100mb/s)

HSPA+: 42Mbps DL, 5.76 UL

TD-HSDPA/HSUPA: 2.8Mbps DL, 2.2Mbps UL

EDGE: Multi Slot Class 12 236.8 kbps DL & UL

GPRS: Multi Slot Class 10 85.6 kbps DL & UL

Frequency Bands:

B2, B4, B5, B7, B12, B13, B14, B17, B25, B26, B41, B42, B43, B48, B66, B71

(Source: <https://mofinetwork.com/product/mofi4500-4gxelte-sim8-vehicle-combo-v3/>)

Internal Module Specs:

NOTE THIS IS NOT A 5G ROUTER

This item is made to work in North America but may also work in many other countries around the world.

For North America, no need to check the bands but if using outside Canada/USA, check the band support for compatibility.

LTE Category 7: 300Mbps DL, 150Mbps UL

Supports up to 2 x Carrier Aggregation

HSPA+: 42Mbps DL, 5.76 UL

TD-HSDPA/HSUPA: 2.8Mbps DL, 2.2Mbps UL

EDGE: Multi Slot Class 12 236.8 kbps DL & UL

GPRS: Multi Slot Class 10 85.6 kbps DL & UL

Frequency Bands:

B2, B4, B5, B7, B12, B13, B14, B17, B25, B26, B41, B42, B43, B48, B66, B71

(Source: <https://mofinetwork.com/product/mofi5500-5gxelte-em7411-combo/>)

Internal Module Specs:

This item is made to work in anywhere on the planet!

5G LTE Category 20: 2000Mbps (4.5Gbps) DL, 660Mbps UL

5 x Carrier Aggregations

HSPA+: 42Mbps DL, 5.76 UL

TD-HSDPA/HSUPA: 2.8Mbps DL, 2.2Mbps UL

EDGE: Multi Slot Class 12 236.8 kbps DL & UL

GPRS: Multi Slot Class 10 85.6 kbps DL & UL

Frequency Bands:

4G/LTE Bands: B1, B2, B3, B4, B5, B7, B8, B9, B12, B13, B14, B17, B18, B19, B20, B21, B25, B26, B28, B29, B30, B32, B34, B38, B39, B40, B41, B42, B43, B46, B48, B66, B71

5G Bands: For 5G: N1, N2, N3, N5, N7, N8, N12, N20, N25, N28, N38, N40, N41, N48, N66, N71, N77, N78, N79

If you want to see if the router is compatible with your provider on the signal side, see what 4G/LTE/5G bands your provider will use and compare to what is available. It will be very hard to find a provider that is not compatible with this product.

(Source: <https://mofinetwork.com/product/mofi5500-5gxelte-em9191-combo-cat20-lte-5g-router-pre-order-expected-to-ship-on-july-06-2021/>)

User equipment Category	Max. L1 datarate Downlink (Mbit/s)	Max. number of DL MIMO layers	Max. L1 datarate Uplink (Mbit/s)	3GPP Release
NB-I	0.68	1	1.0	Rel 13
MI	1.0	1	1.0	
0	1.0	1	1.0	Rel 12
1	10.3	1	5.2	Rel 8
2	51.0	2	25.5	
3	102.0	2	51.0	
4	150.8	2	51.0	
5	299.6	4	75.4	
6	301.5	2 or 4	51.0	Rel 10
7	301.5	2 or 4	102.0	
8	2,998.6	8	1,497.8	
9	452.2	2 or 4	51.0	Rel 11
10	452.2	2 or 4	102.0	
11	603.0	2 or 4	51.0	
12	603.0	2 or 4	102.0	

(Source: <https://www.cablefree.net/wirelesstechnology/4glte/lte-ue-category-class-definitions>)

45. By doing so, Mofi has directly infringed (literally and/or under the doctrine of equivalents) at least Claim 1 of the '458 Patent. Mofi's infringement in this regard is ongoing.

46. Mofi has infringed the '458 Patent by making, having made, using, importing, providing, supplying, distributing, selling or offering for sale products including an apparatus for synchronizing a communication system. The accused product is a receiver in an apparatus for synchronizing a communication system. An LTE compliant base station that is communicating with an accused product can be part of the apparatus, acting as a transmitter. For example, according to the LTE standards, the physical layer performs various functions which include

modulation and demodulation of physical channels, as well as time and frequency synchronization.

Internal Module Specs:

LTE Category 7: 300Mbps DL, 150Mbps UL (note the max this model can handle is up to 100mb/s)
HSPA+: 42Mbps DL, 5.76 UL
TD-HSDPA/HSUPA: 2.8Mbps DL, 2.2Mbps UL
EDGE: Multi Slot Class 12 236.8 kbps DL & UL
GPRS: Multi Slot Class 10 85.6 kbps DL & UL
Frequency Bands:
B2, B4, B5, B7, B12, B13, B14, B17, B25, B26, B41, B42, B43, B48, B66, B71

(Source: <https://mofinetwork.com/product/mofi4500-4gxelte-sim8-vehicle-combo-v3/>)

Internal Module Specs:

NOTE THIS IS NOT A 5G ROUTER

This item is made to work in North America but may also work in many other countries around the world.

For North America, no need to check the bands but if using outside Canada/USA, check the band support for compatibility.

LTE Category 7: 300Mbps DL, 150Mbps UL

Supports up to 2 x Carrier Aggregation

HSPA+: 42Mbps DL, 5.76 UL

TD-HSDPA/HSUPA: 2.8Mbps DL, 2.2Mbps UL

EDGE: Multi Slot Class 12 236.8 kbps DL & UL

GPRS: Multi Slot Class 10 85.6 kbps DL & UL

Frequency Bands:

B2, B4, B5, B7, B12, B13, B14, B17, B25, B26, B41, B42, B43, B48, B66, B71

(Source: <https://mofinetwork.com/product/mofi5500-5gxelte-em7411-combo/>)

Internal Module Specs:

This item is made to work in anywhere on the planet!

5G **LTE Category 20:** 2000Mbps (4.5Gbps) DL, 660Mbps UL

5 x Carrier Aggregations

HSPA+: 42Mbps DL, 5.76 UL

TD-HSDPA/HSUPA: 2.8Mbps DL, 2.2Mbps UL

EDGE: Multi Slot Class 12 236.8 kbps DL & UL

GPRS: Multi Slot Class 10 85.6 kbps DL & UL

Frequency Bands:

4G/LTE Bands: B1, B2, B3, B4, B5, B7, B8, B9, B12, B13, B14, B17, B18, B19, B20, B21, B25, B26, B28, B29, B30, B32, B34, B38, B39, B40, B41, B42, B43, B46, B48, B66, B71

5G Bands: For 5G: N1, N2, N3, N5, N7, N8, N12, N20, N25, N28, N38, N40, N41, N48, N66, N71, N77, N78, N79

If you want to see if the router is compatible with your provider on the signal side, see what 4G/LTE/5G bands your provider will use and compare to what is available. It will be very hard to find a provider that is not compatible with this product.

(Source: <https://mofinetwork.com/product/mofi5500-5gxelte-em9191-combo-cat20-lte-5g-router-pre-order-expected-to-ship-on-july-06-2021/>)

User equipment Category	Max. LI datarate Downlink (Mbit/s)	Max. number of DL MIMO layers	Max. LI datarate Uplink (Mbit/s)	3GPP Release
NB-I	0.68	1	1.0	Rel 13
MI	1.0	1	1.0	
0	1.0	1	1.0	Rel 12
1	10.3	1	5.2	Rel 8
2	51.0	2	25.5	
3	102.0	2	51.0	
4	150.8	2	51.0	
5	299.6	4	75.4	
6	301.5	2 or 4	51.0	Rel 10
7	301.5	2 or 4	102.0	
8	2,998.6	8	1,497.8	
9	452.2	2 or 4	51.0	Rel 11
10	452.2	2 or 4	102.0	
11	603.0	2 or 4	51.0	
12	603.0	2 or 4	102.0	

(Source: <https://www.cablefree.net/wirelesstechnology/4glte/lte-ue-category-class-definitions>)

“Synchronization” refers to the technique applied to ensure the radios in the target LTE basestation are operating within the performance parameters defined by the appropriate 3rd Generation Partners Project (3GPP) standard. Synchronization is achieved by delivering a specifically formatted clock signal or signals to the basestation’s radio circuitry. These signals in turn are used to generate the modulation method’s RF air interface frequency/phase components.

The RF or air interface requirements of LTE are determined by the 3GPP, a collaboration between groups of telecommunications associations, known as the Organizational Partners. The 3GPP’s standardization encompasses radio, core network, and service architecture.

(Source: <https://www.electronicdesign.com/communications/lte-requirements-synchronization-and-standards-support>)

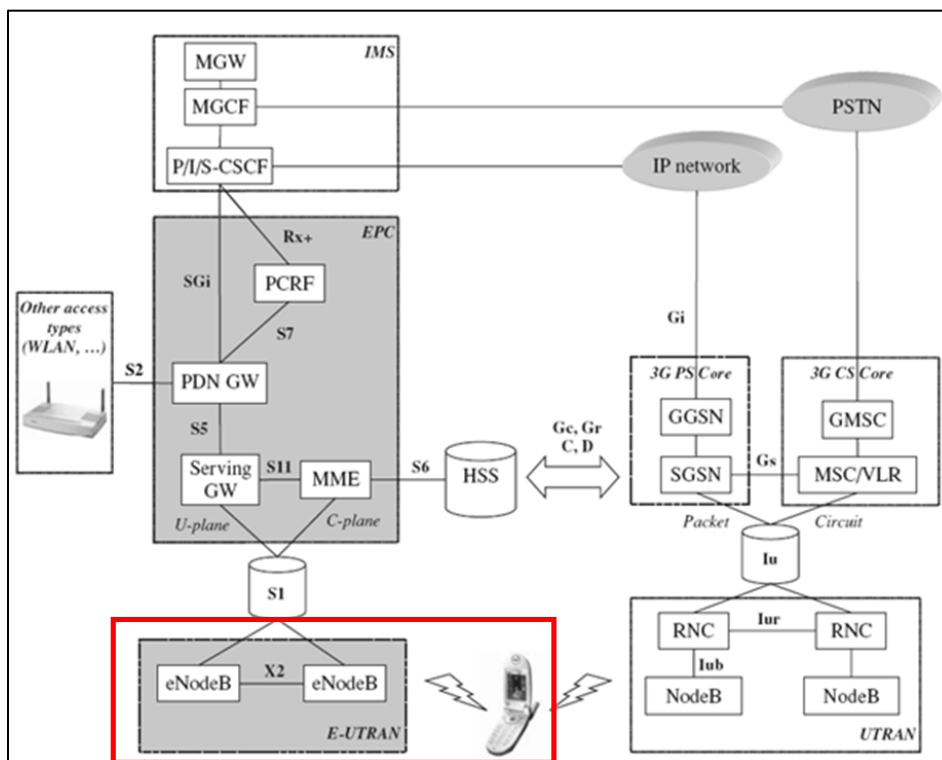

(Source: <https://sites.google.com/site/lteencyclopedia/lte-network-infrastructure-and-elements>)

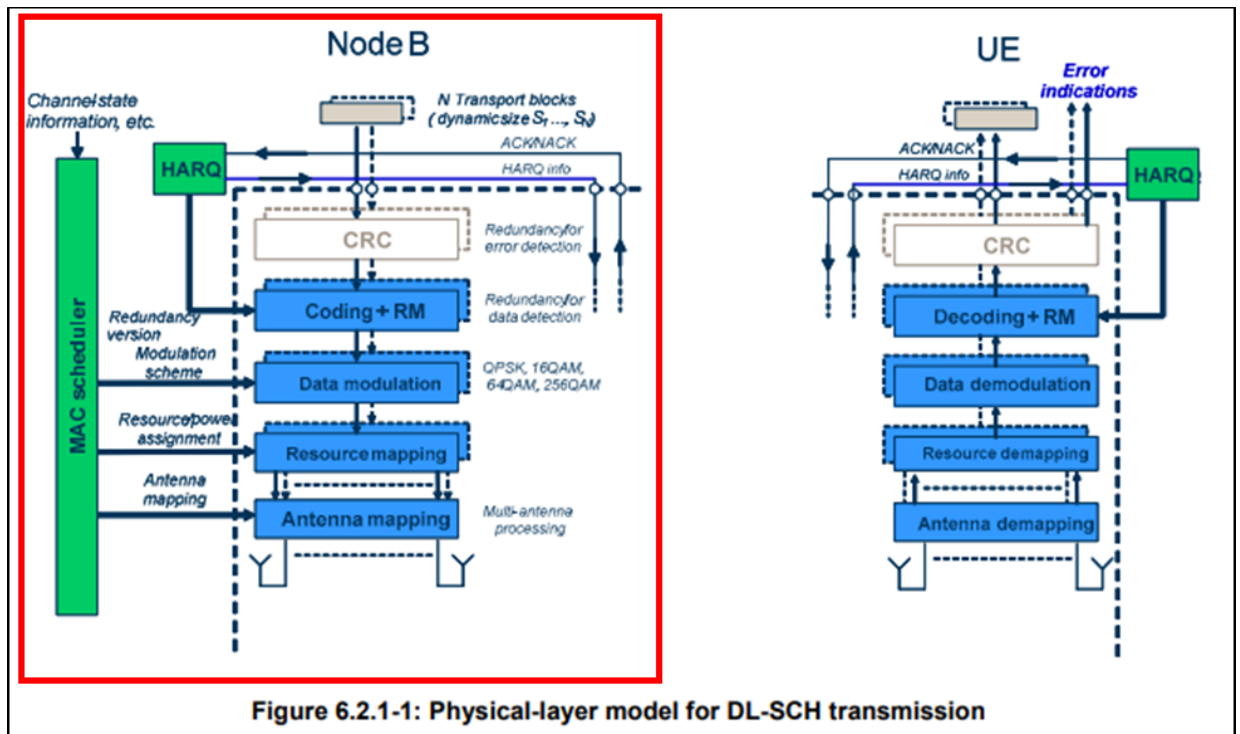

(Source:

https://www.etsi.org/deliver/etsi_ts/136300_136399/136302/15.00.00_60/ts_136302v150000p.pdf)

The physical layer offers data transport services to higher layers. The access to these services is through the use of a transport channel via the MAC sub-layer. The physical layer is expected to perform the following functions in order to provide the data transport service:

- Error detection on the transport channel and indication to higher layers
- FEC encoding/decoding of the transport channel
- Hybrid ARQ soft-combining
- Rate matching of the coded transport channel to physical channels
- Mapping of the coded transport channel onto physical channels
- Power weighting of physical channels
- Modulation and demodulation of physical channels
- Frequency and time synchronisation
- Radio characteristics measurements and indication to higher layers
- Multiple Input Multiple Output (MIMO) antenna processing

(Source:

https://www.etsi.org/deliver/etsi_ts/136200_136299/136201/10.00.00_60/ts_136201v100000p.pdf)

47. The accused products include a number (Q) of Orthogonal Frequency Division Multiplexing (OFDM) modulators, each OFDM modulator producing a frame having at least one inserted symbol, a plurality of data symbols, and cyclic prefixes. Alternatively, on being requested by an accused product, an LTE base station acts as a transmitter and includes a number (Q) of Orthogonal Frequency Division Multiplexing (OFDM) modulators, each OFDM modulator producing a frame having at least one inserted symbol, a plurality of data symbols, and cyclic prefixes. The LTE base station eNodeB acts as the transmitter for the OFDM frames. The physical layer performs the modulation and demodulation of the physical channels. Further, it uses OFDM in the downlink physical channel. Hence, there would be OFDM modulators for modulating the data signals at the base station. The physical layer transmits frames of data on the downlink, that includes data symbols, synchronization symbols such as PSS, SSS and cyclic prefixes.

The physical layer offers data transport services to higher layers. The access to these services is through the use of a transport channel via the MAC sub-layer. The physical layer is expected to perform the following functions in order to provide the data transport service:

- Error detection on the transport channel and indication to higher layers
- FEC encoding/decoding of the transport channel
- Hybrid ARQ soft-combining
- Rate matching of the coded transport channel to physical channels
- Mapping of the coded transport channel onto physical channels
- Power weighting of physical channels
- Modulation and demodulation of physical channels
- Frequency and time synchronisation
- Radio characteristics measurements and indication to higher layers

(Source:

https://www.etsi.org/deliver/etsi_ts/136200_136299/136201/10.00.00_60/ts_136201v100000p.pdf)

4.2.1 Multiple Access

The multiple access scheme for the LTE physical layer is based on Orthogonal Frequency Division Multiplexing (OFDM) with a cyclic prefix (CP) in the downlink, and on Single-Carrier Frequency Division Multiple Access (SC-FDMA) with a cyclic prefix in the uplink. To support transmission in paired and unpaired spectrum, two duplex modes

(Source:

https://www.etsi.org/deliver/etsi_ts/136200_136299/136201/10.00.00_60/ts_136201v100000p.pdf)

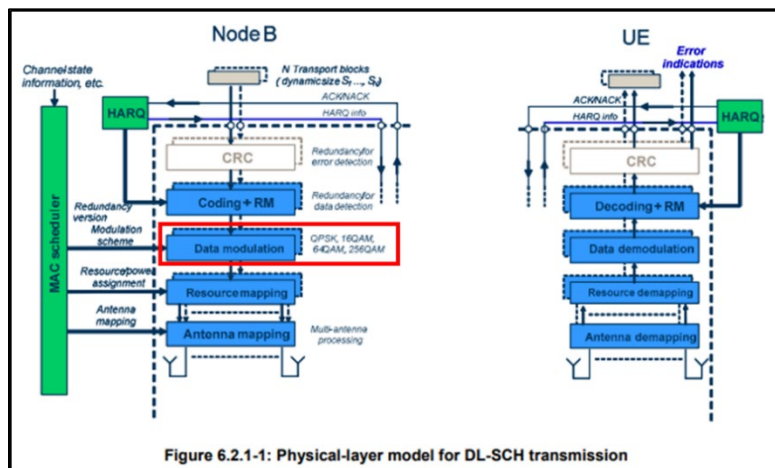

(Source:

https://www.etsi.org/deliver/etsi_ts/136300_136399/136302/15.00.00_60/ts_136302v150000p.pdf)

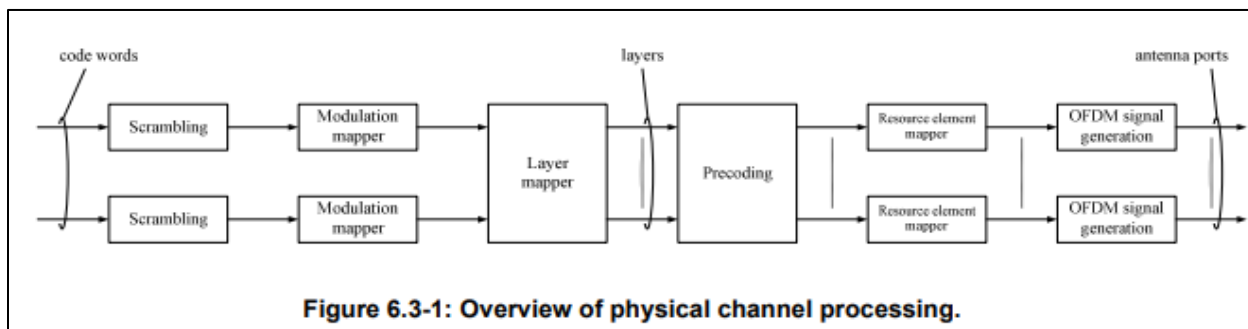

(Source:

https://www.etsi.org/deliver/etsi_ts/136200_136299/136211/08.06.00_60/ts_136211v080600p.pdf)

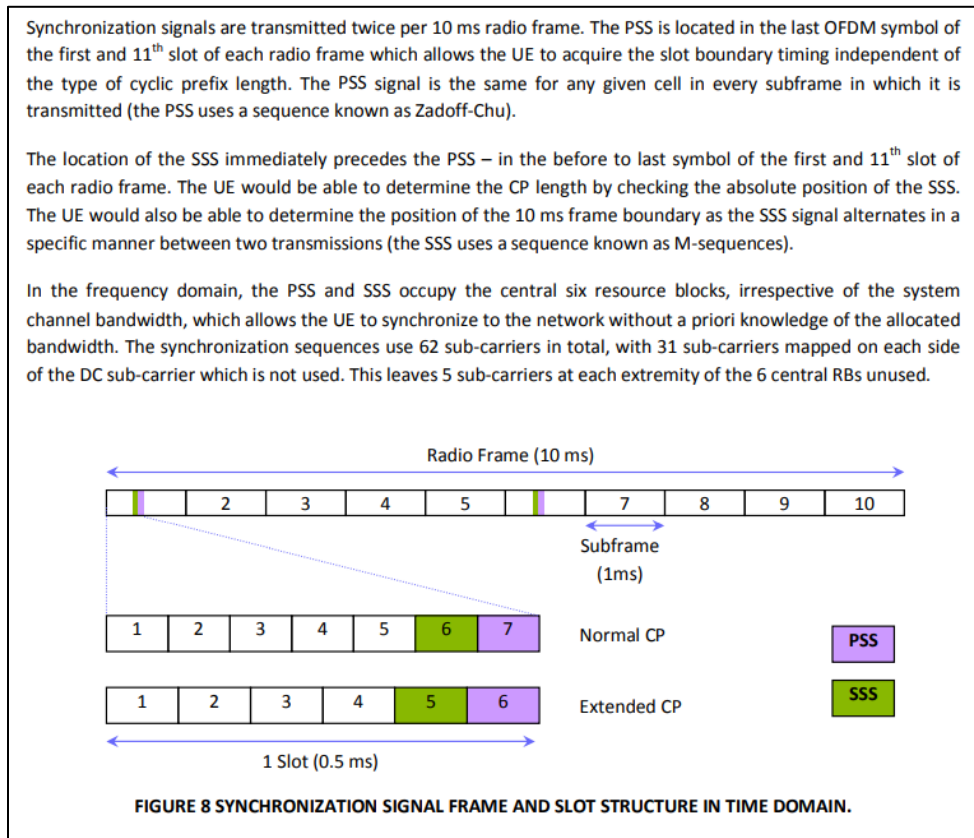

(Source: <https://home.zhaw.ch/kunr/NTM1/literatur/LTE%20in%20a%20Nutshell%20-%20Physical%20Layer.pdf>)

48. The accused products include Q transmitting antennas, each transmitting antenna connected to a respective OFDM modulator, the transmitting antennas configured to transmit a respective frame over a channel. Alternatively, on being requested by an accused product, the LTE base station can act as a transmitter and include Q transmitting antennas, each transmitting antenna connected to a respective OFDM modulator, the transmitting antennas configured to transmit a respective frame over a channel. The LTE base station eNodeB acts as the transmitter for the data frames. The data frames having cyclic prefixes and other OFDM symbols are

transmitted over a channel (PDCCH, etc.). The transmitting antennas of a base station would transmit multiple OFDM frames over a channel. Thus, these transmitting antennas would be connected to OFDM modulators to get the OFDM frames for further transmission.

6.7 Physical control format indicator channel

The physical control format indicator channel carries information about the number of OFDM symbols used for transmission of PDCCHs in a subframe. The set of OFDM symbols possible to use for PDCCH in a subframe is given by Table 6.7-1.

(Source:

[https://www.etsi.org/deliver/etsi_ts/136200_136299/136211/11.05.00_60/ts_136211v110500p.p](https://www.etsi.org/deliver/etsi_ts/136200_136299/136211/11.05.00_60/ts_136211v110500p.pdf)

df)

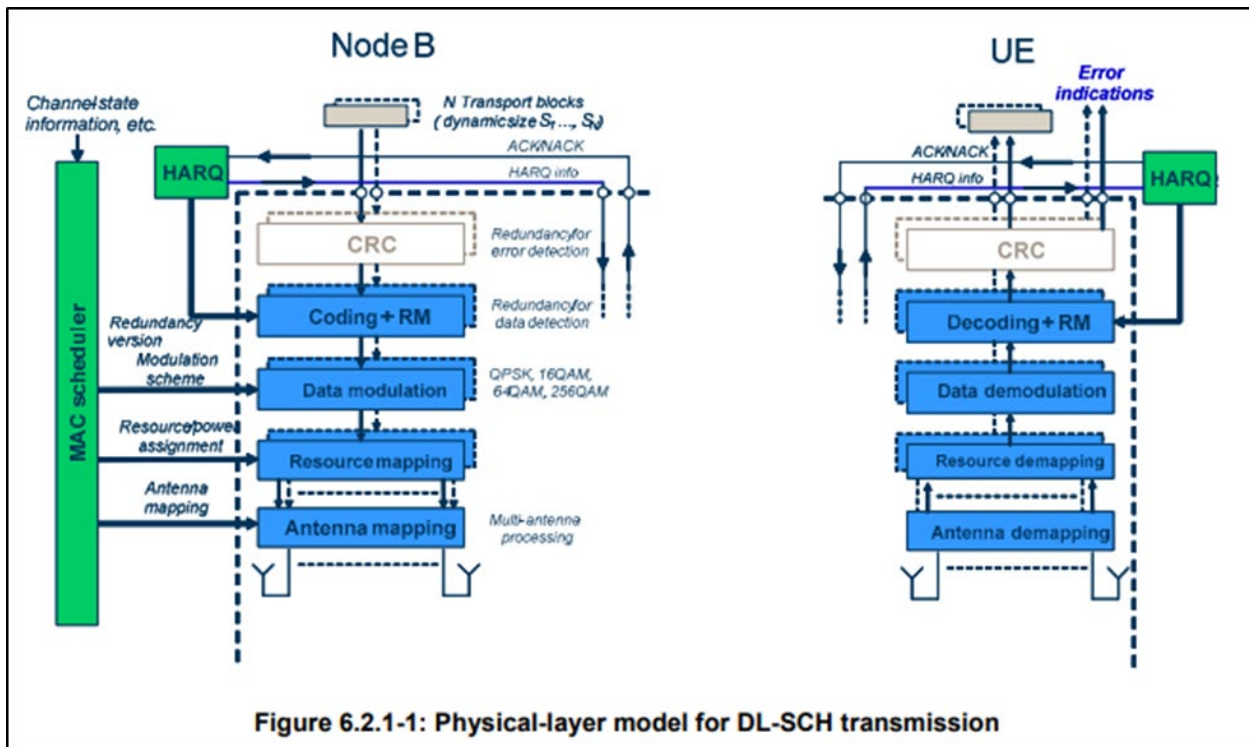

(Source :

[https://www.etsi.org/deliver/etsi_ts/136300_136399/136302/15.00.00_60/ts_136302v150000p.p](https://www.etsi.org/deliver/etsi_ts/136300_136399/136302/15.00.00_60/ts_136302v150000p.pdf)

df)

49. The accused products include a number (L) of receiving antennas for receiving the transmitted frames. For example, the accused products comply with LTE standards and uses MIMO antenna system. These receiving antennas would receive the frames transmitted by the base station.

Internal Module Specs:

LTE Category 7: 300Mbps DL, 150Mbps UL (note the max this model can handle is up to 100mb/s)

HSPA+: 42Mbps DL, 5.76 UL

TD-HSDPA/HSUPA: 2.8Mbps DL, 2.2Mbps UL

EDGE: Multi Slot Class 12 236.8 kbps DL & UL

GPRS: Multi Slot Class 10 85.6 kbps DL & UL

Frequency Bands:

B2, B4, B5, B7, B12, B13, B14, B17, B25, B26, B41, B42, B43, B48, B66, B71

(Source: <https://mofinetwork.com/product/mofi4500-4gxelte-sim8-vehicle-combo-v3/>)

Internal Module Specs:

NOTE THIS IS NOT A 5G ROUTER

This item is made to work in North America but may also work in many other countries around the world.

For North America, no need to check the bands but if using outside Canada/USA, check the band support for compatibility.

LTE Category 7: 300Mbps DL, 150Mbps UL

Supports up to 2 x Carrier Aggregation

HSPA+: 42Mbps DL, 5.76 UL

TD-HSDPA/HSUPA: 2.8Mbps DL, 2.2Mbps UL

EDGE: Multi Slot Class 12 236.8 kbps DL & UL

GPRS: Multi Slot Class 10 85.6 kbps DL & UL

Frequency Bands:

B2, B4, B5, B7, B12, B13, B14, B17, B25, B26, B41, B42, B43, B48, B66, B71

(Source: <https://mofinetwork.com/product/mofi5500-5gxelte-em7411-combo/>)

Internal Module Specs:

This item is made to work in anywhere on the planet!

5G LTE Category 20: 2000Mbps (4.5Gbps) DL, 660Mbps UL

5 x Carrier Aggregations

HSPA+: 42Mbps DL, 5.76 UL

TD-HSDPA/HSUPA: 2.8Mbps DL, 2.2Mbps UL

EDGE: Multi Slot Class 12 236.8 kbps DL & UL

GPRS: Multi Slot Class 10 85.6 kbps DL & UL

Frequency Bands:

4G/LTE Bands: B1, B2, B3, B4, B5, B7, B8, B9, B12, B13, B14, B17, B18, B19, B20, B21, B25, B26, B28, B29, B30, B32, B34, B38, B39, B40, B41, B42, B43, B46, B48, B66, B71

5G Bands: For 5G: N1, N2, N3, N5, N7, N8, N12, N20, N25, N28, N38, N40, N41, N48, N66, N71, N77, N78, N79

If you want to see if the router is compatible with your provider on the signal side, see what 4G/LTE/5G bands your provider will use and compare to what is available. It will be very hard to find a provider that is not compatible with this product.

(Source: <https://mofinetwork.com/product/mofi5500-5gxelte-em9191-combo-cat20-lte-5g-router-pre-order-expected-to-ship-on-july-06-2021/>)

User equipment Category	Max. LI datarate Downlink (Mbit/s)	Max. number of DL MIMO layers	Max. LI datarate Uplink (Mbit/s)	3GPP Release
NB-I	0.68	1	1.0	Rel 13
MI	1.0	1	1.0	
0	1.0	1	1.0	Rel 12
1	10.3	1	5.2	Rel 8
2	51.0	2	25.5	
3	102.0	2	51.0	
4	150.8	2	51.0	
5	299.6	4	75.4	
6	301.5	2 or 4	51.0	Rel 10
7	301.5	2 or 4	102.0	
8	2,998.6	8	1,497.8	
9	452.2	2 or 4	51.0	Rel 11
10	452.2	2 or 4	102.0	
11	603.0	2 or 4	51.0	
12	603.0	2 or 4	102.0	

(Source: <https://www.cablefree.net/wirelesstechnology/4glte/lte-ue-category-class-definitions>)

50. The accused products include L OFDM demodulators, each OFDM demodulator corresponding to a respective receiving antenna, the L OFDM demodulators including a synchronization circuit that processes the received frame in order to synchronize the received frame in both time domain and frequency domain. For example, according to the LTE standards, the physical layer performs various functions which include modulation and demodulation, as well as frequency and time synchronization. Hence, there would be demodulator blocks and synchronization circuits for performing these functions. The procedure of achieving time and frequency synchronizations is called 'Cell Search'.

The physical layer offers data transport services to higher layers. The access to these services is through the use of a transport channel via the MAC sub-layer. The physical layer is expected to perform the following functions in order to provide the data transport service:

- Error detection on the transport channel and indication to higher layers
- FEC encoding/decoding of the transport channel
- Hybrid ARQ soft-combining
- Rate matching of the coded transport channel to physical channels
- Mapping of the coded transport channel onto physical channels
- Power weighting of physical channels
- **Modulation and demodulation of physical channels**
- Frequency and time synchronisation
- Radio characteristics measurements and indication to higher layers

(Source:

https://www.etsi.org/deliver/etsi_ts/136200_136299/136201/10.00.00_60/ts_136201v100000p.pdf)

4.1 Cell search

Cell search is the procedure by which a UE acquires time and frequency synchronization with a cell and detects the physical layer Cell ID of that cell. E-UTRA cell search supports a scalable overall transmission bandwidth corresponding to 6 resource blocks and upwards.

The following signals are transmitted in the downlink to facilitate cell search: the primary and secondary synchronization signals.

A UE may assume the antenna ports 0 – 3 and the antenna port for the primary/secondary synchronization signals of a serving cell are quasi co-located (as defined in [3]) with respect to Doppler shift and average delay.

(Source:

https://www.etsi.org/deliver/etsi_ts/136200_136299/136213/14.02.00_60/ts_136213v140200p.pdf)

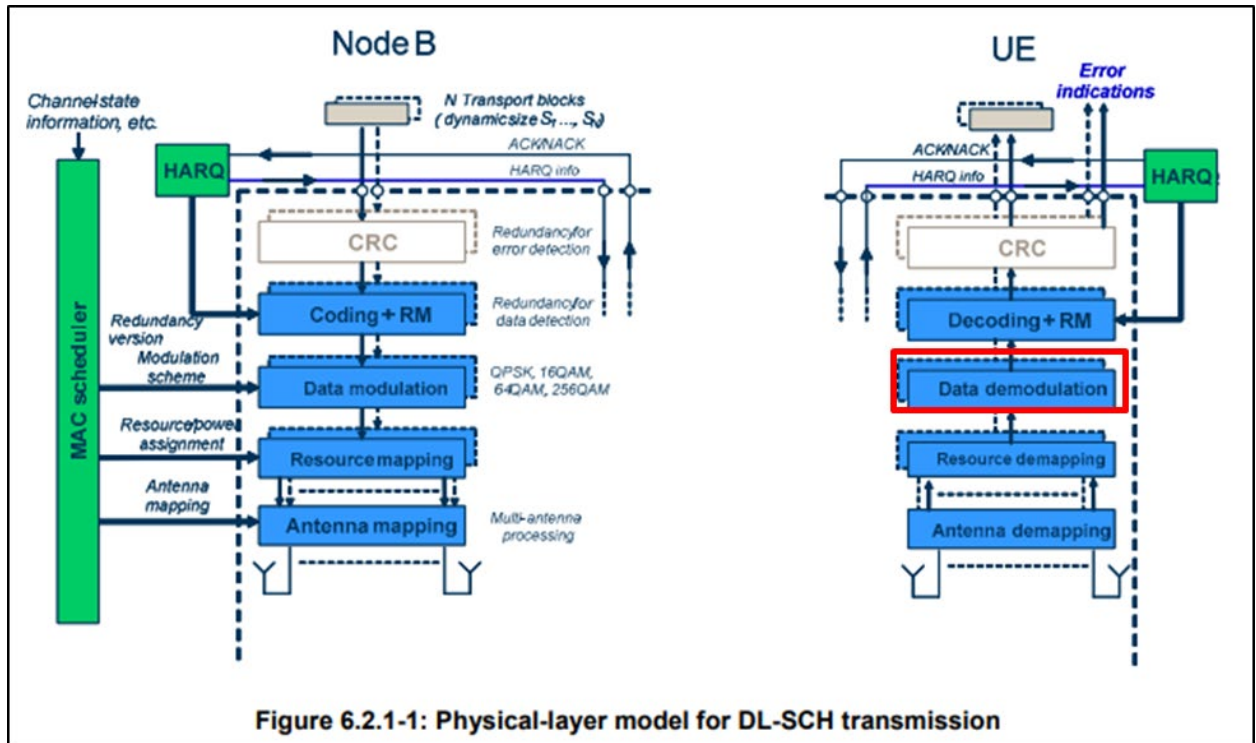

(Source:

https://www.etsi.org/deliver/etsi_ts/136300_136399/136302/15.00.00_60/ts_136302v15000p.pdf)

51. The accused products include wherein each of the L OFDM demodulators comprises a pre-amplifier, a local oscillator, a mixer having a first input and a second input, the first input connected to an output of the pre-amplifier, the second input connected to an output of the local oscillator, an analog-to-digital converter (ADC) connected to an output of the mixer. LTE devices generally include RF Front-end Modules. After the data is transmitted by the base station, the data is received by a receiving antenna of the accused product for further processing. To prevent the demodulator from demodulating the noise associated with the received signal, an RF front end circuit is implemented to increase the SNR of demodulated signal. The RF front end circuit generally consists of amplifiers, local oscillator, filters and mixers. The output from

the mixer is generally fed to an analog-to-digital converter (ADC). This RF front end circuit generally lies at the start of the demodulation process.

The technique to combat a low $SNR_{\text{demod_in}}$ is by adding a front end block, which processes (conditions) the received signal/AWGN/interference before admitting it to the demodulator. This processing can be done in several ways:

(Source: VLSI for Wireless Communication)

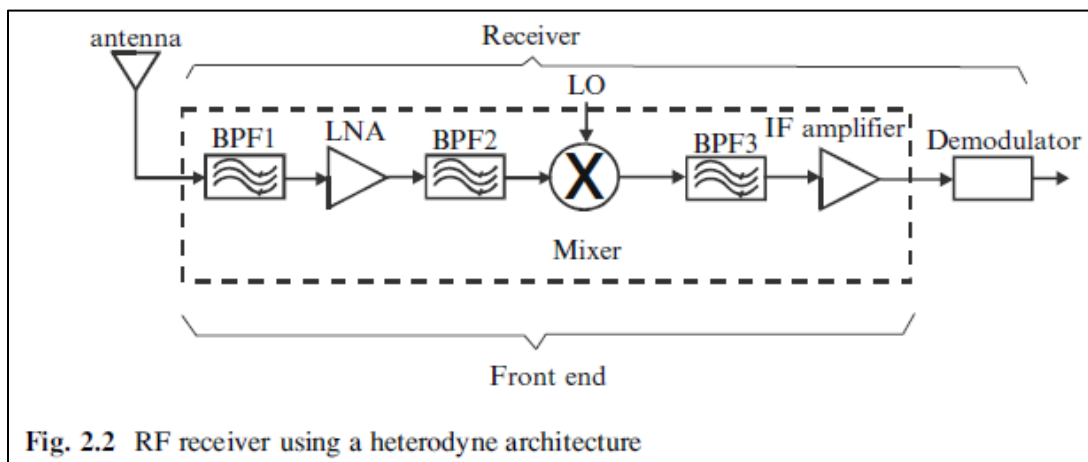

(Source: VLSI for Wireless Communication)

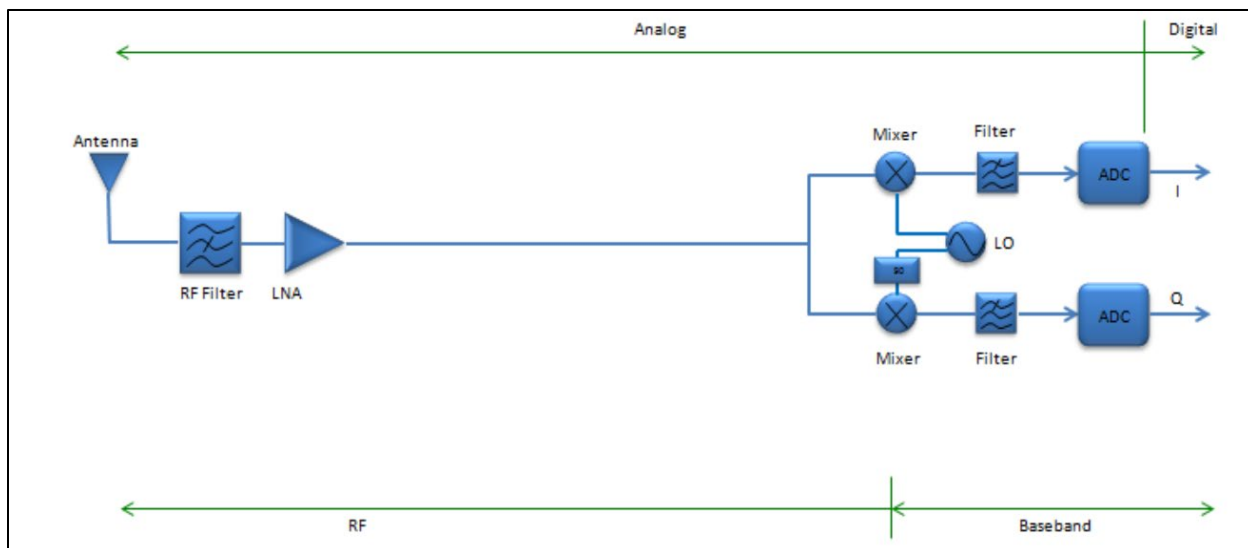

(Source: http://www.sharetechnote.com/html/RF_Introduction.html)

2.4 Rest of Receiver Front End: Nonidealities and Design Parameters

Now that we have talked about the design of filters in the receiver front, we turn our attention to the design of the rest of the components. Normally these components consist of circuits such as LNA, mixer, IF amplifier, and analog/digital (A/D) converter. Unlike filters, their relevant design parameters are different. Hence our first task is to discuss these design parameters.

(Source: VLSI for Wireless Communication)

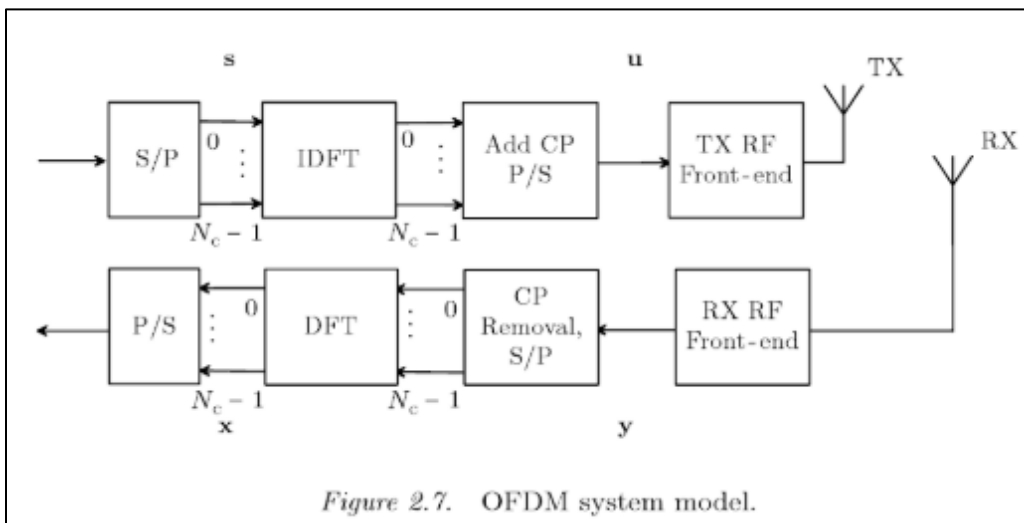

(Source: RF Imperfections in High-rate Wireless Systems: Impact and Digital Compensation, Schenk (2008))

The RF front end is generally defined as everything between the antenna and the digital baseband system. For a receiver, this "between" area includes all the filters, low-noise amplifiers (LNAs), and down-conversion mixer(s) needed to process the modulated signals received at the antenna into signals suitable for input into the baseband analog-to-digital converter (ADC). For this reason, the RF front end is often called the analog-to-digital or RF-to-baseband portion of a receiver.

(Source: https://www.eetimes.com/document.asp?doc_id=1276331)

52. The accused products include the synchronization circuit having one input connected to an output of the ADC. According to the LTE standards, the physical layer performs various functions which include frequency and time synchronization. The procedure of achieving this time and frequency synchronizations is called ‘Cell Search’. Hence, there are synchronization circuits for performing these functions. The synchronization circuit is connected to an ADC.

The physical layer offers data transport services to higher layers. The access to these services is through the use of a transport channel via the MAC sub-layer. The physical layer is expected to perform the following functions in order to provide the data transport service:

- Error detection on the transport channel and indication to higher layers
- FEC encoding/decoding of the transport channel
- Hybrid ARQ soft-combining
- Rate matching of the coded transport channel to physical channels
- Mapping of the coded transport channel onto physical channels
- Power weighting of physical channels
- Modulation and demodulation of physical channels
- Frequency and time synchronisation
- Radio characteristics measurements and indication to higher layers

(Source:

https://www.etsi.org/deliver/etsi_ts/136200_136299/136201/10.00.00_60/ts_136201v10000p.pdf)

4.1 Cell search

Cell search is the procedure by which a UE acquires time and frequency synchronization with a cell and detects the physical layer Cell ID of that cell. E-UTRA cell search supports a scalable overall transmission bandwidth corresponding to 6 resource blocks and upwards.

The following signals are transmitted in the downlink to facilitate cell search: the primary and secondary synchronization signals.

A UE may assume the antenna ports 0 – 3 and the antenna port for the primary/secondary synchronization signals of a serving cell are quasi co-located (as defined in [3]) with respect to Doppler shift and average delay.

(Source:

https://www.etsi.org/deliver/etsi_ts/136200_136299/136213/14.02.00_60/ts_136213v140200p.pdf)

53. The accused products include a cyclic-prefix remover connected to an output of the synchronization circuit, a serial-to-parallel converter connected to an output of the cyclic prefix remover, and a discrete Fournier transform (DFT) stage connected to an output of the serial-to-parallel converter, an output of the DFT stage connected to another input to the synchronization circuit. Cyclic prefixes are added in the preamble for each transmitted frame. In a general OFDM system, a cyclic prefix remover circuit would be present at the receiver end. The output from the cyclic prefix remover circuit is fed to a serial-to-parallel converter for performing a DFT operation on its output.

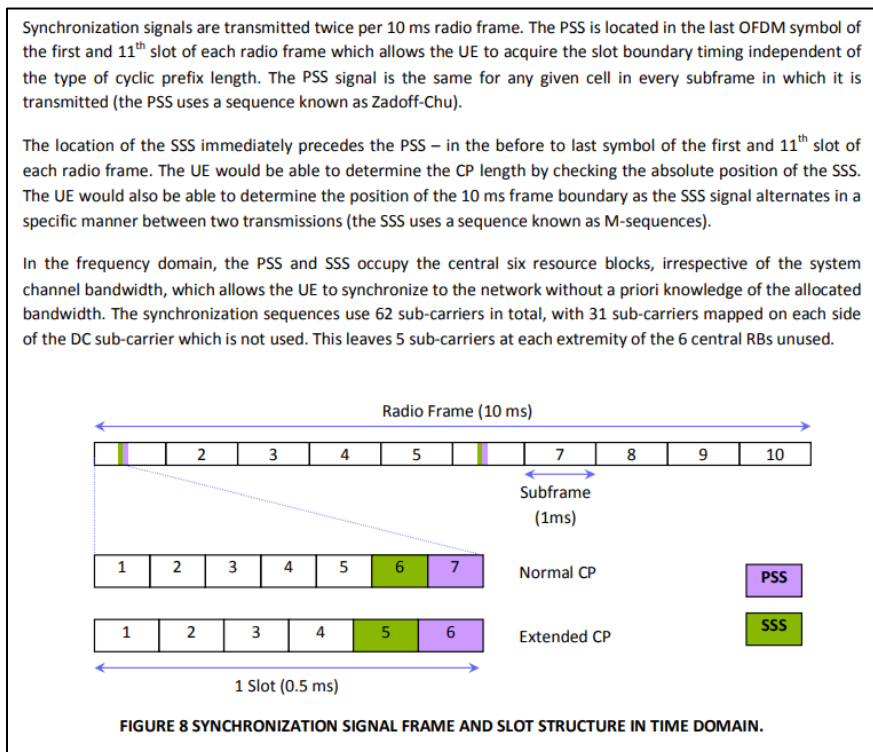

(Source: <https://home.zhaw.ch/kunr/NTM1/literatur/LTE%20in%20a%20Nutshell%20-%20Physical%20Layer.pdf>)

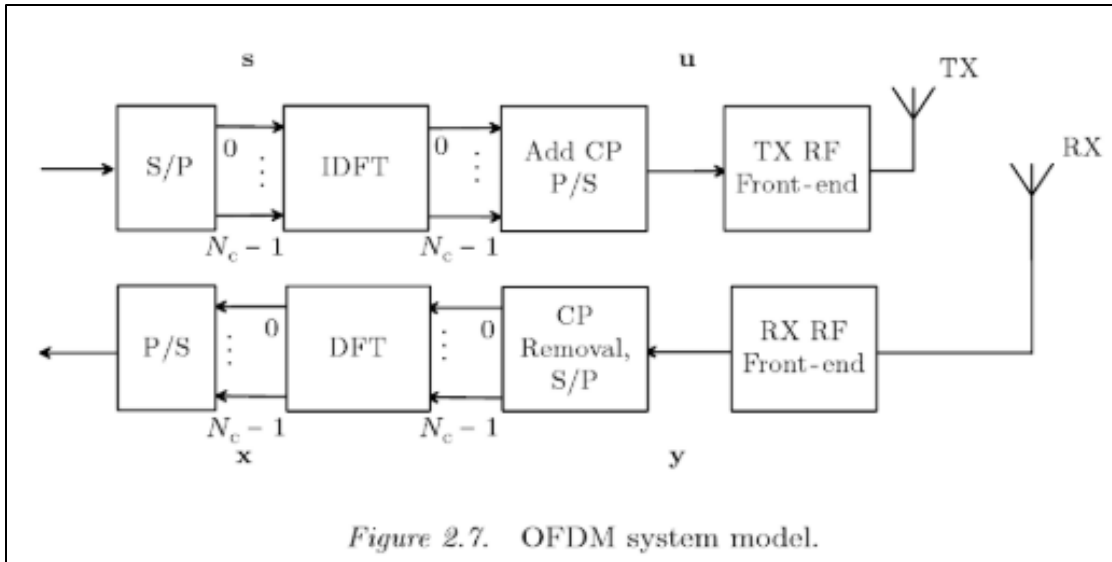

(Source: RF Imperfections in High-rate Wireless Systems: Impact and Digital Compression, Schenk, Tim)

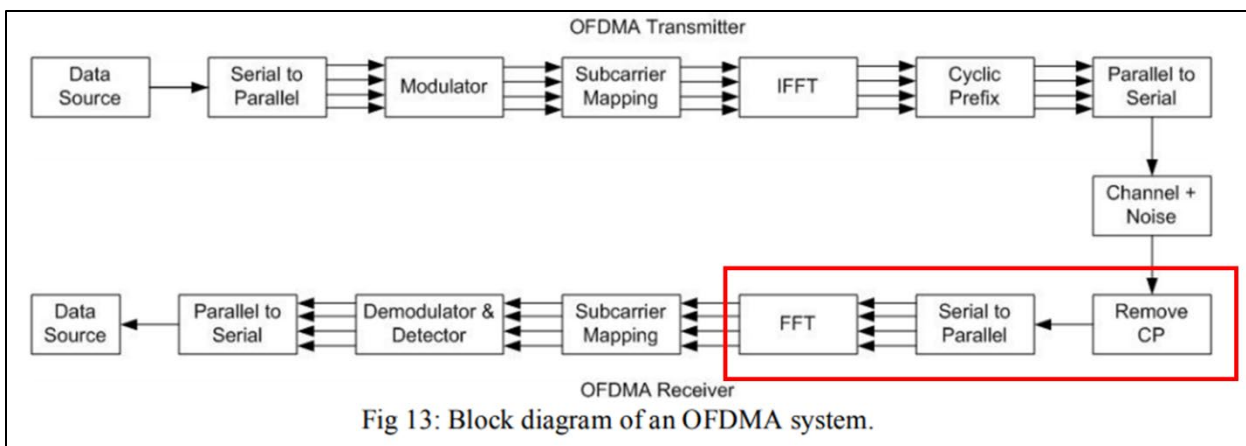

(Source: <http://ijettjournal.org/volume-12/number-2/IJETT-V12P214.pdf>)

54. Mofi has had actual knowledge of the ‘458 Patent at least as of the date when it was notified of the filing of this action. By the time of trial, Mofi will have known and intended (since receiving such notice) that its continued actions would infringe and actively induce and contribute to the infringement of one or more claims of the ‘458 Patent.

55. Mofi has also indirectly and willfully infringed, and continues to indirectly and willfully infringe, the ‘458 Patent, as explained further below in the “Additional Allegations Regarding Infringement” section.

56. American Patents has been damaged as a result of the infringing conduct by Mofi alleged above. Thus, Mofi is liable to American Patents in an amount that adequately compensates it for such infringements, which, by law, cannot be less than a reasonable royalty, together with interest and costs as fixed by this Court under 35 U.S.C. § 284.

57. American Patents has neither made nor sold unmarked articles that practice the ‘458 Patent, and is entitled to collect pre-filing damages for the full period allowed by law for infringement of the ‘458 Patent.

ADDITIONAL ALLEGATIONS REGARDING INFRINGEMENT

58. In addition to any specific products mentioned above, the accused products also include at least MOFI4500-4GXeLTE-SIM4-VEHICLE-COMBO V3, MOFI4500-4GXeLTE-SIM7-VEHICLE-COMBO V3, MOFI4500-4GXeLTE-SIM8-VEHICLE-COMBO V3, MOFI4500-4GXeLTE, MOFI5500-5GXeLTE-EM7411-COMBO, MOFI5500-5GXeLTE-EM7411-DUAL-COMBO, MOFI5500-5GXeLTE-EM9191-COMBO CAT20 LTE + 5G ROUTER, MOFI5500-5GXeLTE-EM7690-COMBO CAT20 LTE ROUTER, MOFI4500-4GXeLTE-SIM4 V3, MOFI4500-4GXeLTE-SIM4-GPS COMBO V3, MOFI4500-4GXeLTE-SIM4-COMBO V3, MOFI4500-4GXeLTE-SIM7-COMBO V3, MOFI4500-4GXeLTE-SIM8-COMBO V3, and MOFI4500-4GXeLTE-SIM8 V3.

59. Mofi has also indirectly infringed the ‘782 Patent, the ‘304 Patent, and the ‘458 Patent by inducing others to directly infringe the ‘782 Patent, the ‘304 Patent, and the ‘458 Patent. Mofi has induced the end-users, Mofi’s customers, to directly infringe (literally and/or

under the doctrine of equivalents) the '782 Patent, the '304 Patent, and the '458 Patent by using the accused products.

60. Mofi took active steps, directly and/or through contractual relationships with others, with the specific intent to cause them to use the accused products in a manner that infringes one or more claims of the patents-in-suit, including, for example, Claim 30 of the '782 Patent, Claim 1 of the '304 Patent, and Claim 1 of the '458 Patent.

61. Such steps by Mofi included, among other things, advising or directing customers and end-users to use the accused products in an infringing manner; advertising and promoting the use of the accused products in an infringing manner; and/or distributing instructions that guide users to use the accused products in an infringing manner.

62. Mofi has performed these steps, which constitute induced infringement, with the knowledge of the '782 Patent, the '304 Patent, and the '458 Patent and with the knowledge that the induced acts constitute infringement.

63. Mofi was and is aware that the normal and customary use of the accused products by Mofi's customers would infringe the '782 Patent, the '304 Patent, and the '458 Patent. Mofi's inducement is ongoing.

64. Mofi has also induced its affiliates, or third-party manufacturers, shippers, distributors, retailers, or other persons acting on its or its affiliates' behalf, to directly infringe (literally and/or under the doctrine of equivalents) the '782 Patent, the '304 Patent, and the '458 Patent by importing, selling, offering to sell, and/or using the accused products.

65. Mofi has at least a significant role in placing the accused products in the stream of commerce in Texas and elsewhere in the United States.

66. Mofi directs or controls the making of accused products and their shipment to the United States, using established distribution channels, for sale in Texas and elsewhere within the United States.

67. Mofi directs or controls the sale of the accused products into established United States distribution channels, including sales to nationwide retailers.

68. Mofi's established United States distribution channels include one or more United States based affiliates (e.g., at least Mofi Distribution).

69. Mofi directs or controls the sale of the accused products nationwide through its own websites as well as through nationwide distributors and retailers, including for sale in Texas and elsewhere in the United States, and expects and intends that the accused products will be so sold.

70. Mofi took active steps, directly and/or through contractual relationships with others, with the specific intent to cause such persons to import, sell, or offer to sell the accused products in a manner that infringes one or more claims of the patents-in-suit, including, for example, Claim 30 of the '782 Patent, Claim 1 of the '304 Patent, and Claim 1 of the '458 Patent.

71. Such steps by Mofi included, among other things, making or selling the accused products outside of the United States for importation into or sale in the United States, or knowing that such importation or sale would occur; and directing, facilitating, or influencing its affiliates, or third-party manufacturers, shippers, distributors, retailers, or other persons acting on its or their behalf, to import, sell, or offer to sell the accused products in an infringing manner.

72. Mofi performed these steps, which constitute induced infringement, with the knowledge of the '782 Patent, the '304 Patent, and the '458 Patent and with the knowledge that the induced acts would constitute infringement.

73. Mofi performed such steps in order to profit from the eventual sale of the accused products in the United States.

74. Mofi's inducement is ongoing.

75. Mofi has also indirectly infringed by contributing to the infringement of the '782 Patent, the '304 Patent, and the '458 Patent. Mofi has contributed to the direct infringement of the '782 Patent, the '304 Patent, and the '458 Patent by the end-user of the accused products.

76. The accused products have special features that are specially designed to be used in an infringing way and that have no substantial uses other than ones that infringe the '782 Patent, the '304 Patent, and the '458 Patent, including, for example, Claim 30 of the '782 Patent, Claim 1 of the '304 Patent, and Claim 1 of the '458 Patent.

77. As described above, the special features include improved wireless communication capabilities used in a manner that infringes the '782 Patent, the '304 Patent, and the '458 Patent.

78. The special features constitute a material part of the invention of one or more of the claims of the '782 Patent, the '304 Patent, and the '458 Patent and are not staple articles of commerce suitable for substantial non-infringing use.

79. Mofi's contributory infringement is ongoing.

80. Furthermore, Mofi has a policy or practice of not reviewing the patents of others (including instructing its employees to not review the patents of others), and thus has been

willfully blind of American Patents' patent rights. *See, e.g.*, M. Lemley, "Ignoring Patents," 2008 Mich. St. L. Rev. 19 (2008).

81. Mofi's actions are at least objectively reckless as to the risk of infringing valid patents and this objective risk was either known or should have been known by Mofi.

82. Mofi has knowledge of the '782 Patent, the '304 Patent, and the '458 Patent.

83. Mofi's customers have infringed the '782 Patent, the '304 Patent, and the '458 Patent.

84. Mofi encouraged its customers' infringement.

85. Mofi's direct and indirect infringement of the '782 Patent, the '304 Patent, and the '458 Patent is, has been, and/or continues to be willful, intentional, deliberate, and/or in conscious disregard of American Patents' rights under the patents.

86. American Patents has been damaged as a result of the infringing conduct by Mofi alleged above. Thus, Mofi is liable to American Patents in an amount that adequately compensates it for such infringements, which, by law, cannot be less than a reasonable royalty, together with interest and costs as fixed by this Court under 35 U.S.C. § 284.

JURY DEMAND

American Patents hereby requests a trial by jury on all issues so triable by right.

PRAYER FOR RELIEF

American Patents requests that the Court find in its favor and against Mofi, and that the Court grant American Patents the following relief:

a. Judgment that one or more claims of the '782 Patent, the '304 Patent, and the '458 Patent have been infringed, either literally and/or under the doctrine of equivalents, by Mofi and/or all others acting in concert therewith;

b. A permanent injunction enjoining Mofi and its officers, directors, agents, servants, affiliates, employees, divisions, branches, subsidiaries, parents, and all others acting in concert therewith from infringement of the '782 Patent, the '304 Patent, and the '458 Patent; or, in the alternative, an award of a reasonable ongoing royalty for future infringement of the '782 Patent, the '304 Patent, and the '458 Patent by such entities;

c. Judgment that Mofi account for and pay to American Patents all damages to and costs incurred by American Patents because of Mofi's infringing activities and other conduct complained of herein, including an award of all increased damages to which American Patents is entitled under 35 U.S.C. § 284;

d. That American Patents be granted pre-judgment and post-judgment interest on the damages caused by Mofi's infringing activities and other conduct complained of herein;

e. That this Court declare this an exceptional case and award American Patents its reasonable attorney's fees and costs in accordance with 35 U.S.C. § 285; and

f. That American Patents be granted such other and further relief as the Court may deem just and proper under the circumstances.

Dated: December 21, 2021

Respectfully submitted,

/s/ Zachariah S. Harrington

Matthew J. Antonelli

Texas Bar No. 24068432

matt@ahtlawfirm.com

Zachariah S. Harrington

Texas Bar No. 24057886

zac@ahtlawfirm.com

Larry D. Thompson, Jr.

Texas Bar No. 24051428

larry@ahtlawfirm.com

Christopher Ryan Pinckney

Texas Bar No. 24067819

ryan@ahtlawfirm.com

ANTONELLI, HARRINGTON
& THOMPSON LLP
4306 Yoakum Blvd., Ste. 450
Houston, TX 77006
(713) 581-3000

Stafford Davis
State Bar No. 24054605
sdavis@stafforddavisfirm.com
Catherine Bartles
Texas Bar No. 24104849
cbartles@stafforddavisfirm.com
THE STAFFORD DAVIS FIRM
815 South Broadway Avenue
Tyler, Texas 75701
(903) 593-7000
(903) 705-7369 fax

Attorneys for American Patents LLC