

Dist., New Taipei City 221, Taiwan. Acer Inc. owns 100% of the shares of Boardwalk Capital Holdings limited. Boardwalk Capital Holdings limited owns 100% of the shares of Acer American Holdings Corporation. Acer American Holdings Corporation owns 100% of the shares of Gateway, Inc. Gateway, Inc. holds more than 10% of the shares of Acer America Corporation. Acer Inc. holds at least a 10% interest in and, on information and belief, a controlling interest in Acer America Corporation.

3. On information and belief, Acer America Corporation is a corporation organized and existing under the laws of California. Acer America Corporation maintains a place of business in this District, including at 1394 Eberhardt Rd, Temple, Texas 76504.

4. On information and belief, K&D Technology Co., Ltd is a Chinese entity located at K&D Industrial Park, No. 9 Tongfu Road, Pingdong Community, Pingdi Street, Longgang District, Shenzhen, People's Republic of China. K&D's TFT-LCD panels are incorporated into electronic devices such as tablets under the Acer brand name. These electronic devices are imported into the United States, distributed to retailers, and sold to end-users via the internet and in brick and mortar stores in the Western District of Texas. Thus, K&D does business in the State of Texas and in the Western District of Texas.

5. On information and belief, each Defendant, individually and with Acer Group, is engaged in making, using, selling, offering for sale, and/or importing, and/or induces its subsidiaries, affiliates, retail partners, and customers in the making, using, selling, offering for sale, and/or importing throughout the United States, including within this District, products, such as tablets with TFT-LCD panels, accused of infringement. Acer America Corporation operates in agency as part of the Acer Group. Acer America Corporation in agency with the Acer Group provides a distribution channel of infringing products within this District and the U.S. nationally.

Further, Acer America Corporation regularly imports and inserts into the stream of commerce tablets, such that infringing tablets will be offered for sale and sold in this District and throughout the United States. K&D specifically supplies TFT-LCD panels to the other Defendants for use in their tablets.

6. On information and belief, Acer Group makes up an interrelated group of companies which collectively comprise one of the largest electronics manufacturers in the United States.

7. On information and belief, the Acer Group Defendants, individually, together, and/or in concert, participate in the design, development, manufacture, sale for importation into the United States, offers for sale for importation into the United States, importation into the United States, sale within the United States after importation, and offers for sale within the United States after importation, of tablets with TFT-LCD panels that infringe the Asserted Patents.

8. On information and belief, Acer Group operates in agency with each other as a group. *See, e.g.*, <https://www.acer-group.com/ag/en/TW/content/home> (“Acer is one of the world’s top ICT companies with a presence in more than 160 countries.”). Acer induces its subsidiaries, affiliates, retail partners, and customers in the making, using, selling, offering for sale, and/or importing throughout the United States, including within this District, products, such as tablets with TFT-LCD panels, accused of infringement. Acer Group provides a distribution channel of infringing products within this District and the U.S. nationally. Acer Group Defendants, between and amongst themselves, purposefully direct the Accused Products into established distribution channels within this District and the U.S. nationally.

9. On information and belief, Acer Group maintains a corporate presence in the United States via at least its, U.S.-based sales subsidiaries including, Acer America Corporation. Acer

America provides sales and distribution support in North America as part of the Acer Group and for related entities. Acer America is an agent of Acer Inc. At the direction and control of the Acer Group, U.S.-based sales subsidiaries including, Acer America imports infringing products, such as tablets with TFT-LCD panels, into the United States and this District.

10. On information and belief, Acer Group and its U.S.-based sales subsidiaries (which act as part of a global network of overseas sales and manufacturing subsidiaries on behalf of Acer) have operated as agents of one another and vicariously as parts of the same business group to work in concert together and enter into agreements that are nearer than arm's length. For example, Acer Inc., alone and via at least the activities of its U.S.-based sales subsidiaries (e.g., Acer America), conducts business in the United States, including importing, distributing, and selling tablets with TFT-LCD panels that incorporate devices, systems, and processes that infringe the Asserted Patents in Texas and this judicial district. *See Trois v. Apple Tree Auction Center, Inc.*, 882 F.3d 485, 490 (5th Cir. 2018) (“A defendant may be subject to personal jurisdiction because of the activities of its agent within the forum state...”); *see also Cephalon, Inc. v. Watson Pharmaceuticals, Inc.*, 629 F. Supp. 2d 338, 348 (D. Del. 2009) (“The agency theory may be applied not only to parents and subsidiaries, but also to companies that are ‘two arms of the same business group,’ operate in concert with each other, and enter into agreements with each other that are nearer than arm's length.”).

11. Through offers to sell, sales, imports, distributions, and other related agreements to transfer ownership of Defendants' electronics, such as tablets with TFT-LCD panels, with distributors and customers operating in and maintaining a significant business presence in the U.S. and/or its U.S. subsidiaries, Acer America Corporation, Defendants do business in the U.S., the state of Texas, and in this District.

JURISDICTION AND VENUE

12. This action arises under the patent laws of the United States, namely 35 U.S.C. §§ 271, 281, and 284-285, among others.

13. This Court has subject matter jurisdiction pursuant to 28 U.S.C. §§ 1331 and 1338(a).

14. Venue is proper in this judicial district pursuant to 28 U.S.C. §§ 1391(c) and 1400(b). Acer Inc. and K&D are foreign entities and may be sued in any judicial district under 28 U.S.C. § 1391(c)(3). Acer America Corporation has committed acts of infringement in this District and has regular and established places of business in this District, including at least 1394 Eberhardt Rd, Temple, Texas 76504.

Acer Group Defendants

15. This Court has general and specific personal jurisdiction over the Acer Group Defendants pursuant to due process and/or the Texas Long Arm Statute because, *inter alia*, (i) The Acer Group Defendants have done and continue to do business in Texas and (ii) The Acer Group Defendants have, directly and through intermediaries, committed and continue to commit acts of patent infringement in the State of Texas, including making, using, offering to sell, and/or selling accused products in Texas, and/or importing accused products into Texas, including by Internet sales and sales via retail and wholesale stores, inducing others to commit acts of patent infringement in Texas, and/or committing a least a portion of any other infringements alleged herein. The Acer Group Defendants have placed, and are continuing to place, infringing products into the stream of commerce, via an established distribution channel, with the knowledge and/or understanding that such products are sold in Texas, including in this District. The Acer Group Defendants have derived substantial revenues from its infringing acts occurring within Texas and

within this District. The Acer Group Defendants have substantial business in this State and judicial district, including: (A) at least part of its infringing activities alleged herein; and (B) regularly doing or soliciting business, engaging in other persistent conduct, and/or deriving substantial revenue from infringing goods offered for sale, sold, and imported, and services provided to Texas residents vicariously through and/or in concert with its alter egos, intermediaries, agents, distributors, importers, customers, subsidiaries, and/or consumers.

16. This Court has personal jurisdiction over the Acer Group Defendants, directly or through intermediaries, distributors, importers, customers, subsidiaries, and/or consumers including their U.S.-based sales subsidiaries, e.g., Acer America. Through direction and control of such subsidiaries, the Acer Group Defendants have committed acts of direct and/or indirect patent infringement within Texas, and elsewhere within the United States, giving rise to this action and/or has established minimum contacts with Texas such that personal jurisdiction over the Acer Group Defendants would not offend traditional notions of fair play and substantial justice. Acer America is controlled by Acer Inc. The primary business of Acer America is the marketing and sale of electronic products in the United States. Acer Inc. has a controlling ownership interest in Acer America and maintains more than half of the voting rights for such subsidiaries as its basis for control. Upon information and belief, Acer Inc. compensates Acer America for its sales support services in the United States. As such, Acer Inc. has a direct financial interest in its U.S.-based subsidiaries, and vice versa.

17. Personal jurisdiction is proper because Acer Group Defendants have committed acts of infringement in this District. This Court has personal jurisdiction over the Acer Group Defendants because, *inter alia*, this action arises from activities the Acer Group Defendants purposefully directed towards the State of Texas and this District.

18. Exercising personal jurisdiction over the Acer Group Defendants in this District would not be unreasonable given Defendants' contacts in this District, the interest in this District of resolving disputes related to products sold herein, and the harm that would occur to VPV.

19. In addition, the Acer Group Defendants have knowingly induced and continue to knowingly induce infringement within this District by advertising, marketing, offering for sale and/or selling devices pre-loaded with infringing functionality within this District, to consumers, customers, manufacturers, distributors, resellers, partners, and/or end users, and providing instructions, user manuals, advertising, and/or marketing materials which facilitate, direct or encourage the use of infringing functionality with knowledge thereof.

20. Personal jurisdiction also exists specifically over each of the Acer Group Defendants because each, directly or through affiliates, subsidiaries, agents, or intermediaries, transacts business in this State or purposefully directed at this State (including, without limitation, retail stores including Best Buy and Walmart) by making, importing, offering to sell, selling, and/or having sold infringing products within this State and District or purposefully directed at this State or District.

21. Personal jurisdiction also exists specifically over each of the Acer Group Defendants because the Acer Group Defendants have overlapping executives, interlocking corporate structures, and close relationships as manufacturer, importer, and distributor of the products accused of infringement.

22. To the extent any foreign Defendant is not subject to jurisdiction in any state's court of general jurisdiction, exercising jurisdiction over such Defendant in this State and this District would be consistent with due process and this State's long-arm statute and under national contacts in light of facts alleged in this Complaint.

23. In addition, each of the Acer Group Defendants, directly or through affiliates, subsidiaries, agents, or intermediaries, places infringing products into the stream of commerce knowing they will be sold and used in Texas, and economically benefits from the retail sale of infringing products in this State. Acer also advertises its infringing products and provides customer support of its infringing products to consumers in Texas and this District through its agent's websites.

24. On information and belief, Acer controls or otherwise directs and authorizes all activities of its U.S.-based sales subsidiaries. Such directed and authorized activities include, the U.S. Subsidiaries' using, offering for sale, selling, and/or importing the Accused Products, their components, and/or products containing the same that incorporate the fundamental technologies covered by the Asserted Patents. The Acer Group Defendants' U.S.-based sales subsidiaries are authorized to import, distribute, sell, or offer for sale the Accused Products on behalf of Defendants. For example, Acer researches, designs, develops, and manufactures tablets, including the Acer Iconia One 10, and then directs its U.S.-based sales subsidiaries to import, distribute, offer for sale, and sell the Accused Products in the United States. *See, e.g., United States v. Hui Hsiung*, 778 F.3d 738, 743 (9th Cir. 2015) (finding that the sale of infringing products to third parties rather than for direct import into the U.S. did not "place [defendants'] conduct beyond the reach of United States law [or] escape culpability under the rubric of extraterritoriality"). Furthermore, the Acer Group Defendants' U.S.-based sales subsidiaries also administer, on behalf of Acer Group, requests for service under and any disputes arising from the Acer Group Defendants' limited warranty of the Accused Products sold in the U.S., including in Texas and this judicial district. Thus, the Acer Group Defendants' U.S.-based sales subsidiaries conduct infringing activities on behalf of Defendants.

25. On information and belief, the Acer Group Defendants' U.S.-based sales subsidiaries corporate presence in the United States gives Acer substantially the business advantages that it would have enjoyed if it conducted its business through its own offices or paid agents in the state. The Acer Group Defendants' U.S.-based sales subsidiaries are authorized to import, distribute, sell, and offer for sale the Acer Group Defendants' products, including tablets incorporating infringing devices and processes, on behalf of the Acer Group Defendants. For example, the Acer Group Defendants' U.S.-based sales subsidiaries operate within the Acer Group Defendants' global network of sales subsidiaries in North and South America, Europe, Asia, Australia, and the Middle East. In the U.S., including within the Western District of Texas, the Acer Group Defendants' tablets with TFT-LCD panels, which comprise infringing devices and processes, are imported, distributed, offered for sale, and sold.

26. Via the Acer Group Defendants' alter egos, agents, intermediaries, distributors, importers, customers, subsidiaries, and/or consumers maintaining a business presence, operating in, and/or residing in the U.S., the Acer Group Defendants' products, including products and processes accused of infringing the Asserted Patents, are or have been widely distributed and sold in retail stores, both brick and mortar and online, in Texas including within this judicial district. *See Litecubes, LLC v. Northern Light Products, Inc.*, 523 F.3d 1353, 1369-70 (Fed. Cir. 2008) (“[T]he sale [for purposes of § 271] occurred at the location of the buyer.”); *see also Semcon IP Inc. v. Kyocera Corp.*, No. 2:18-cv-00197-JRG, 2019 WL 1979930, at *3 (E.D. Tex. May 3, 2019) (denying accused infringer's motion to dismiss because plaintiff sufficiently plead that purchases of infringing products outside of the United States for importation into and sales to end users in the U.S. may constitute an offer to sell under § 271(a)). For example, the Acer Group Defendants'

tablets are sold to end users by the U.S.-based subsidiaries, distributors, and customers online and at retail stores located throughout the Western District of Texas.

27. On information and belief, Acer has placed and continues to place infringing products and/or products that practice infringing processes into the stream of commerce via established distribution channels comprising at least subsidiaries and distributors, such as Acer America Corporation, and customers such as Walmart, Best Buy, and Amazon, with the knowledge and/or intent that those products are and/or will be imported, used, offered for sale, sold, and continue to be sold in the United States and Texas, including in this judicial district. As a result, Acer has, vicariously through and/or in concert with its alter egos, agents, intermediaries, distributors, importers, customers, subsidiaries, and/or consumers, placed the Accused Products into the stream of commerce via established distribution channels with the knowledge and/or intent that those products were sold and continue to be sold in the United States and Texas, including in this judicial district.

28. In the alternative, the Court has personal jurisdiction over the Acer Group Defendants under Federal Rule of Civil Procedure 4(k)(2), because the claims for patent infringement in this action arise under federal law, the Acer Group Defendants are not subject to the jurisdiction of the courts of general jurisdiction of any state, and exercising jurisdiction over the Acer Group Defendants is consistent with the U.S. Constitution.

K&D

29. This Court has personal jurisdiction over K&D, directly or through alter egos, intermediaries, connected persons, joint venture parties, agents, associates, business partners, distributors, importers, customers, subsidiaries, and/or consumers, such as the Acer Group Defendants, to whom K&D supplies TFT-LCD panels. K&D, via at least the activities of the Acer

Group Defendants, has committed acts of direct and/or indirect patent infringement within Texas, and elsewhere within the United States giving rise to this action and/or has established minimum contacts with Texas. Upon information and belief, the TFT-LCD panels in the Acer tablets accused of infringing the Asserted Patents are manufactured, assembled, and/or packaged and tested outside the U.S. by K&D. Furthermore, K&D, alone and in consort with others, also imports the accused TFT-LCD panels into the U.S., distributes such products in the U.S., offers to sell such products in the U.S., and/or sells them in the U.S., including selling them prior to importation. K&D, acting alone or in consort with others, has placed and continues to place the K&D TFT-LCD panels accused of infringing the Asserted Patents into the stream of commerce that ends with sales of those products in the United States. In doing so, K&D knew or reasonably should have known that its products would be and are now being distributed, marketed, and sold in Texas, including in this District. Personal jurisdiction, therefore, over K&D would not offend traditional notions of fair play and substantial justice.

30. K&D has placed and continues to place infringing TFT-LCD panels products into the stream of commerce using established distribution channels with the knowledge and understanding that such products are, will be, and continue to be sold, offered for sale, and/or imported into this judicial district and the State of Texas. For example, as part of the Acer Defendants' relationship with K&D, Acer, on behalf of and for the mutual benefit of K&D, imported, offered for sale, advertised, and sold K&D TFT-LCD panels tablet products, including, but not limited to, K&D Technology LCD Model No. KD101N37-40NA-A10 incorporated in at the accused Acer Iconia One 10. Such K&D LCD Products were sold in retail stores, both brick and mortar and online, within this judicial district and in Texas. *See Litecubes, LLC v. Northern Light Products, Inc.*, 523 F.3d 1353, 1369-70 (Fed. Cir. 2008) (“[T]he sale [for purposes of § 271]

occurred at the location of the buyer.”); *see also Semcon IP Inc. v. Kyocera Corporation*, No. 2:18-cv-00197-JRG, 2019 WL 1979930, at *3 (E.D. Tex. May 3, 2019) (denying accused infringer’s motion to dismiss because plaintiff sufficiently plead that purchases of infringing products outside of the United States for importation into and sales to end users in the U.S. may constitute an offer to sell under § 271(a)).

31. K&D has placed and continues to place Acer products into the stream of commerce using established distribution channels infringing with the knowledge and understanding that such products are, will be, and continue to be sold, offered for sale, and/or imported into this judicial district and the State of Texas. As part of the Acer Defendants’ relationship with K&D, the Acer Defendants, on behalf of and for the mutual benefit of K&D, imported, offered for sale, advertised, and sold K&D LCD Products including K&D Technology LCD Model No. KD101N37-40NA-A10 incorporated in at least Acer Iconia One 10 tablet. Such K&D LCD Products were sold in retail stores, both brick and mortar and online, within this judicial district and in Texas.

32. In the alternative, the Court has personal jurisdiction over K&D under Federal Rule of Civil Procedure 4(k)(2), because the claims for patent infringement in this action arise under federal law, K&D is not subject to the jurisdiction of the courts of general jurisdiction of any state, and exercising jurisdiction over K&D is consistent with the U.S. Constitution.

THE ASSERTED PATENTS AND TECHNOLOGY

33. Upon information and belief, a significant portion of operating revenue of the Defendant K&D is derived from the manufacture and sale of TFT-LCD flat panel displays and components, which are imported into the United States by Acer and ultimately sold to U.S. consumers.

34. The Asserted Patents cover at least TFT-LCD tablets, their components, including infringing TFT-LCD panels made by K&D, and, in some cases, incorporated into Acer tablets

(referred to as the “Accused LCD Products”). Examples of K&D Accused LCD Products include K&D Technology LCD Model No. KD101N37-40NA-A10 incorporated in at least the Acer Iconia One 10 tablet.

35. The labels for K&D Technology LCD Model No. KD101N37-40NA-A10 and for the Acer Iconia One 10 product are shown below:



36. The Asserted Patents cover, for example, Defendants’ processes for making TFT-LCD panels. Below is a schematic cross-sectional view of a TFT from K&D Technology LCD Model No. KD101N37-40NA-A10. The images show an amorphous silicon film formed on a substrate with an n-type region in the top surface of the amorphous silicon film. Plasma processing is performed to provide the n-type region (e.g., phosphorus-doped a-Si) in the top surface of the amorphous silicon film.

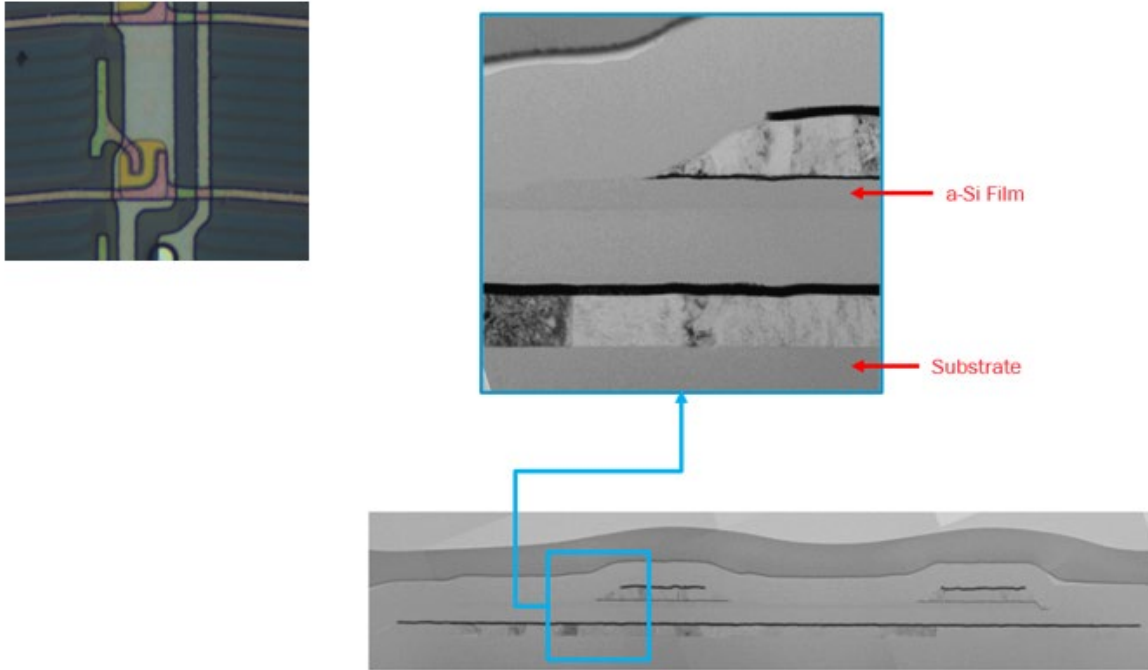

37. As shown below, aluminum source and drain electrodes are formed on the amorphous silicon with the n-type amorphous silicon film there between. The source and drain electrodes were determined to be made of aluminum (Al).

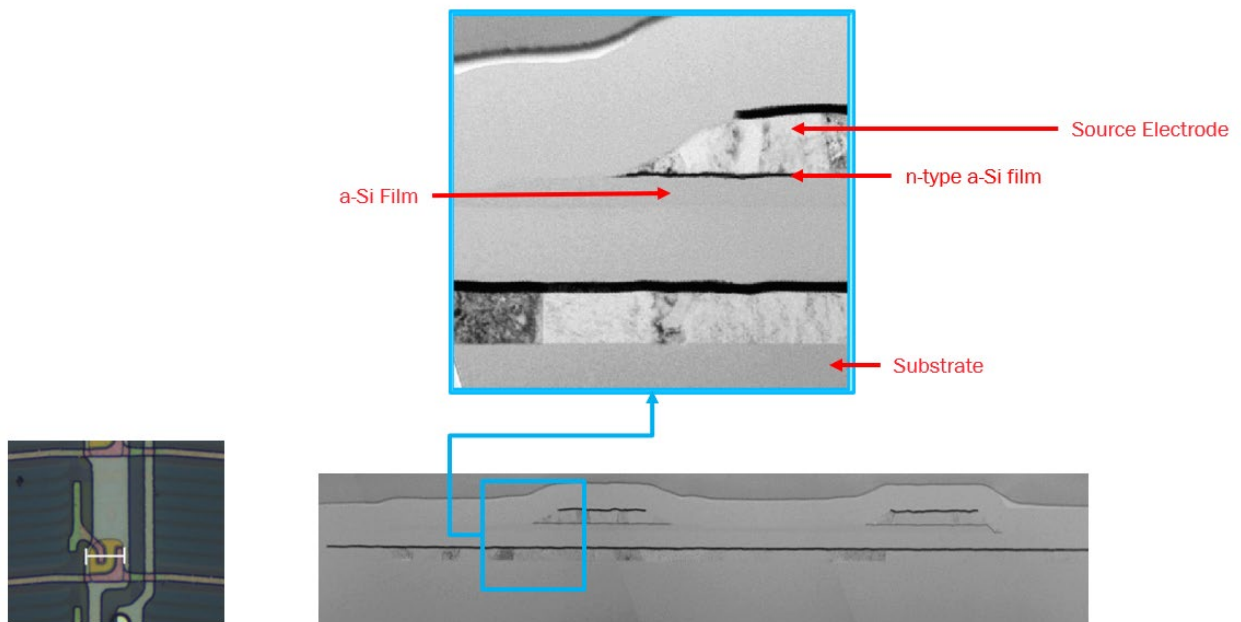

38. The Asserted Patents cover liquid-crystal display devices, as shown below, having an aluminum interconnection line disposed over an insulating plate by way of an underlying insulating layer.

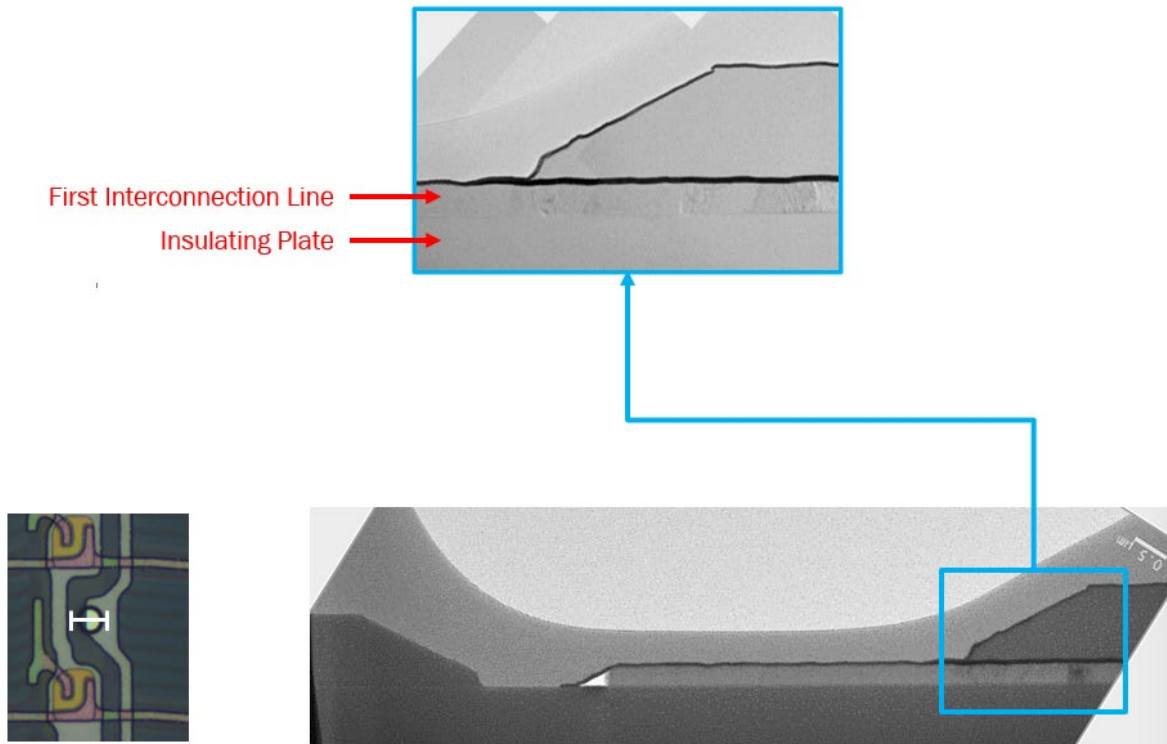

39. The Accused LCD Product, shown below, has an insulating layer that covers the interconnection line and a contact hole that exposes part of the interconnection line.

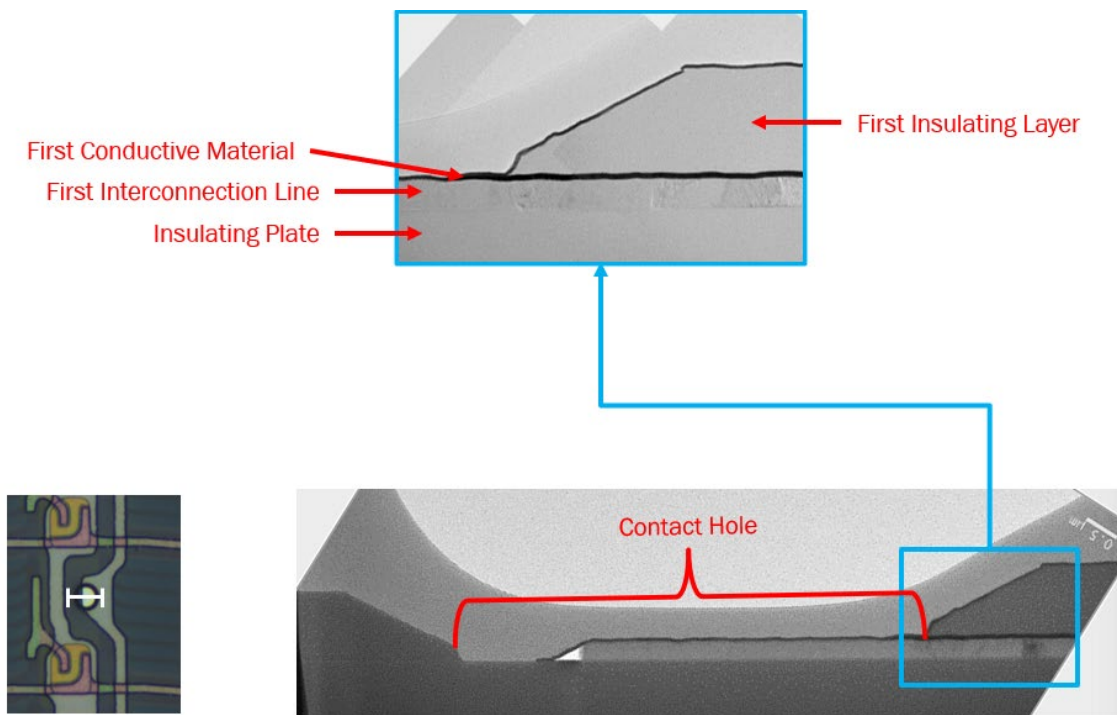

40. As shown below, a first conductive material made of ITO is in contact with the exposed part of the interconnection line and covers the whole exposed part.

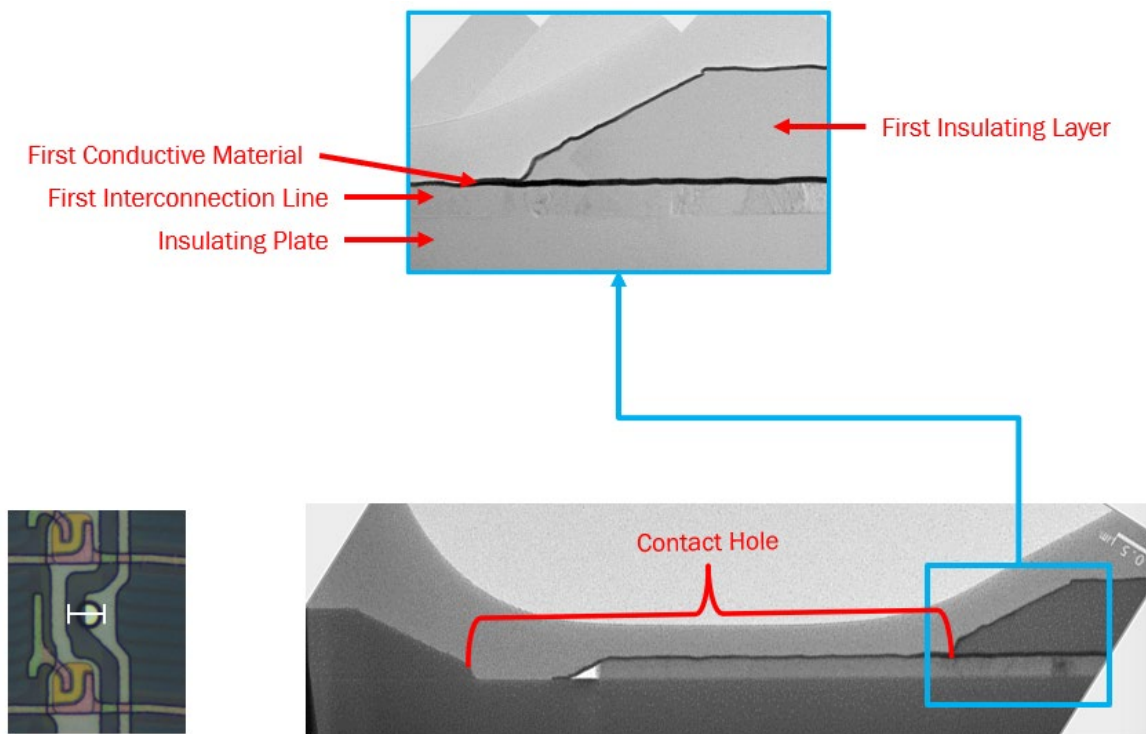

41. The Accused LCD Product has a transparent conductive layer (ITO) in contact with the first conductive material, as shown below.

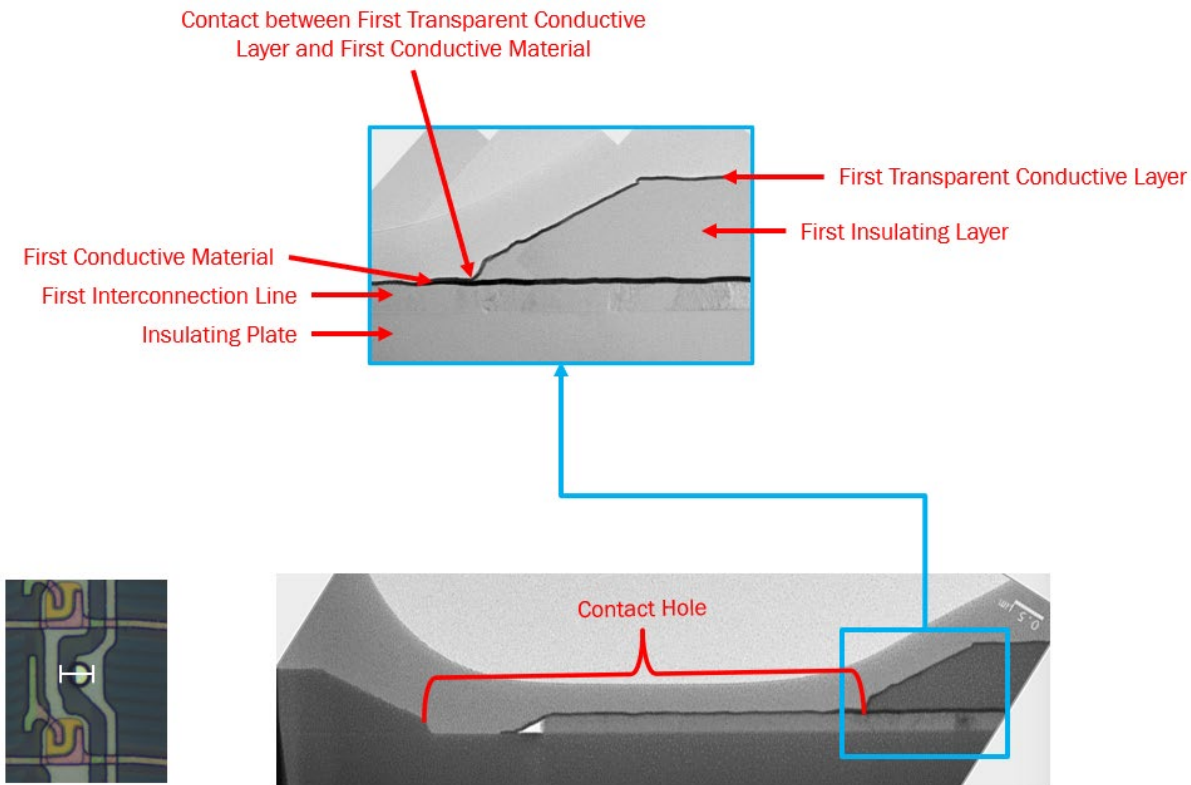

42. In the Accused LCD Product, the transparent conductive layer, first interconnection line, and first conductive material are electrically connected, as shown below.

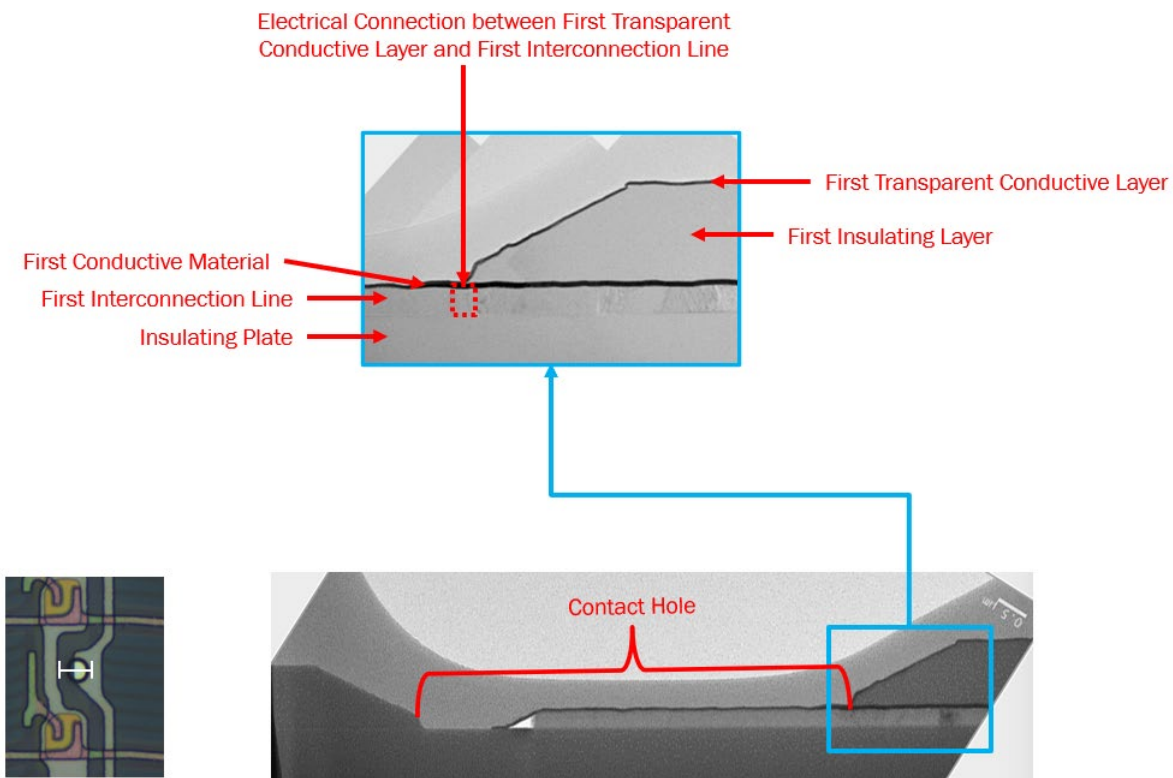

43. The Asserted Patents also cover the Accused LCD Product, such as K&D Technology LCD Model No. KD101N37-40NA-A10 (incorporated in Acer Iconia One 10 tablet), which has a first substrate with a principal surface (e.g., the inner surface), as shown below.

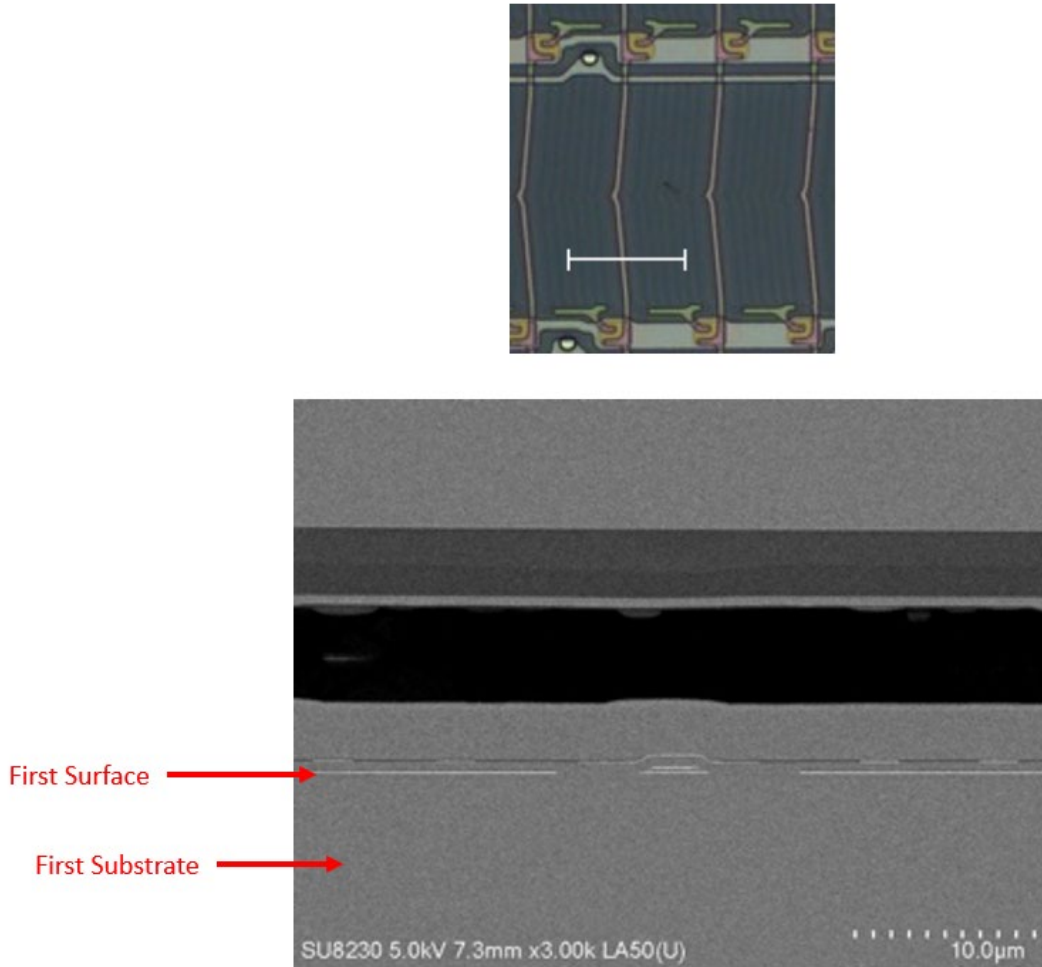

44. The Accused LCD Product, as shown below, has a first alignment film formed on the first principal surface which was subjected to an aligning treatment (necessary to set the direction of the optical/polarizing axis), as shown below.

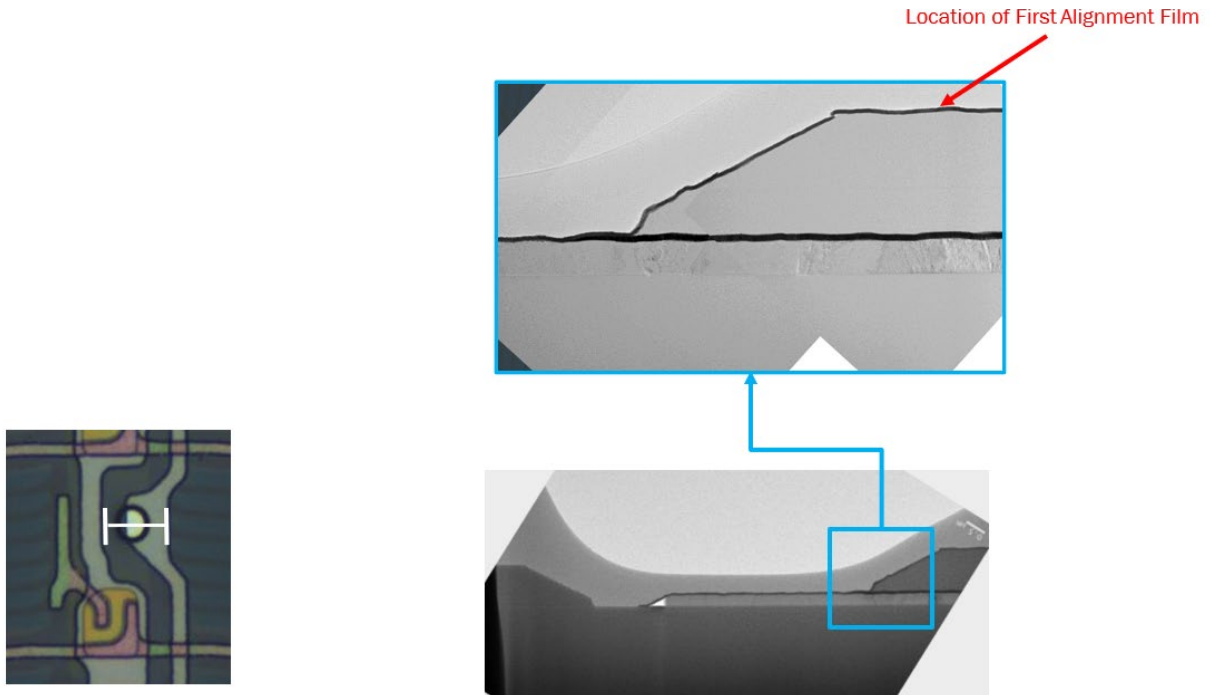

45. As shown below, the Accused LCD Product has a second substrate (e.g., a color filter layer) with a second principal surface (e.g., the inner surface). The Accused LCD Product has a second alignment film formed on the principal surface of the second substrate and is oppositely disposed to the alignment film on the first substrate. Alignment is done in same direction to allow parallel alignment.

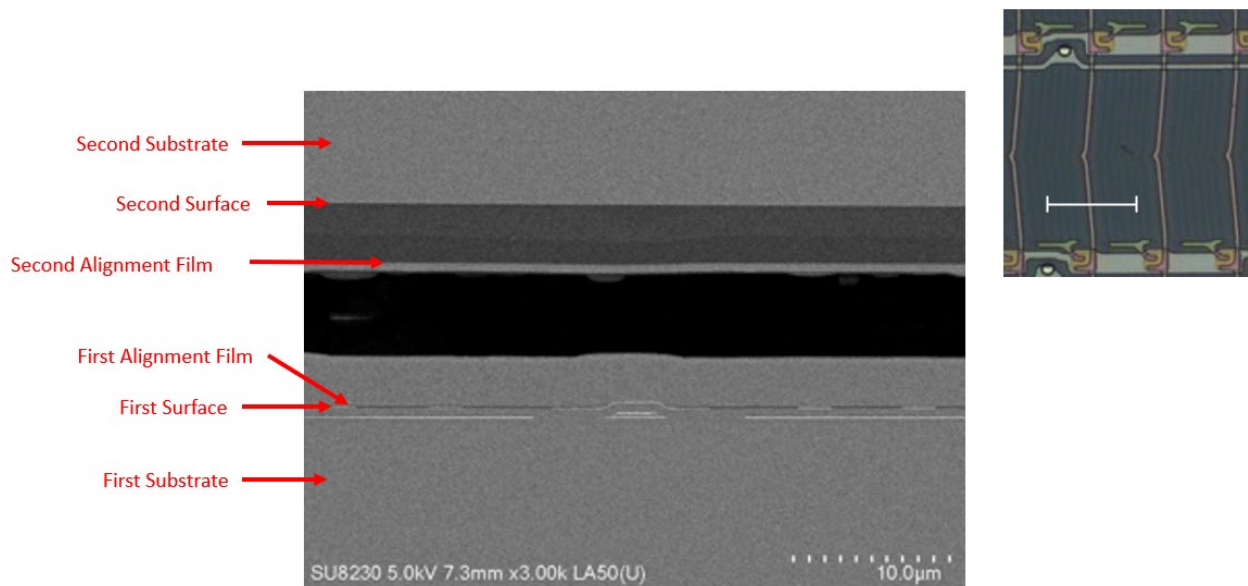

46. As shown below, the Accused LCD Product has a predetermined space is between the first and second alignment films in which the liquid crystal resides.

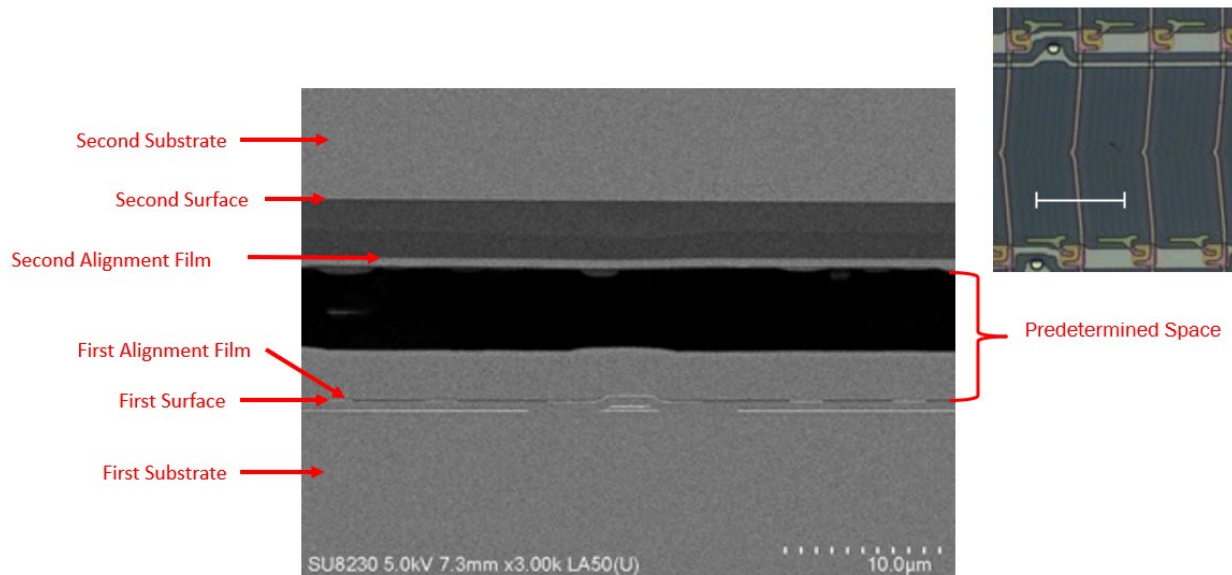

47. The Asserted Patents also cover the Accused LCD Product, because it has to have an active matrix type liquid crystal display device with two opposing insulating substrates and liquid crystal in-between, as illustrated below in reference to K&D Technology LCD Model No. KD101N37-40NA-A10, as shown below.

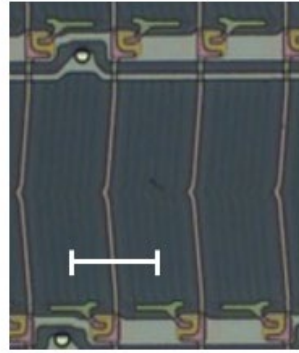

Second Transparent Insulating Substrate

Location of Liquid Crystals

First Transparent Insulating Substrate

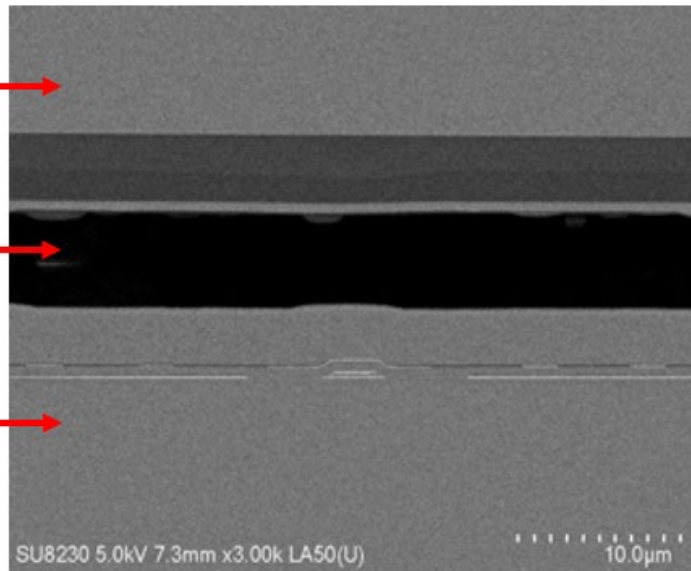

48. The Accused LCD Product referenced above also has a pixel electrode and a common electrode with a common longitudinal axis that generate an electric field in the liquid crystal layer parallel to the substrates, as shown below. The liquid crystal layer has non-zero initial alignment angles relative to the common longitudinal axis.

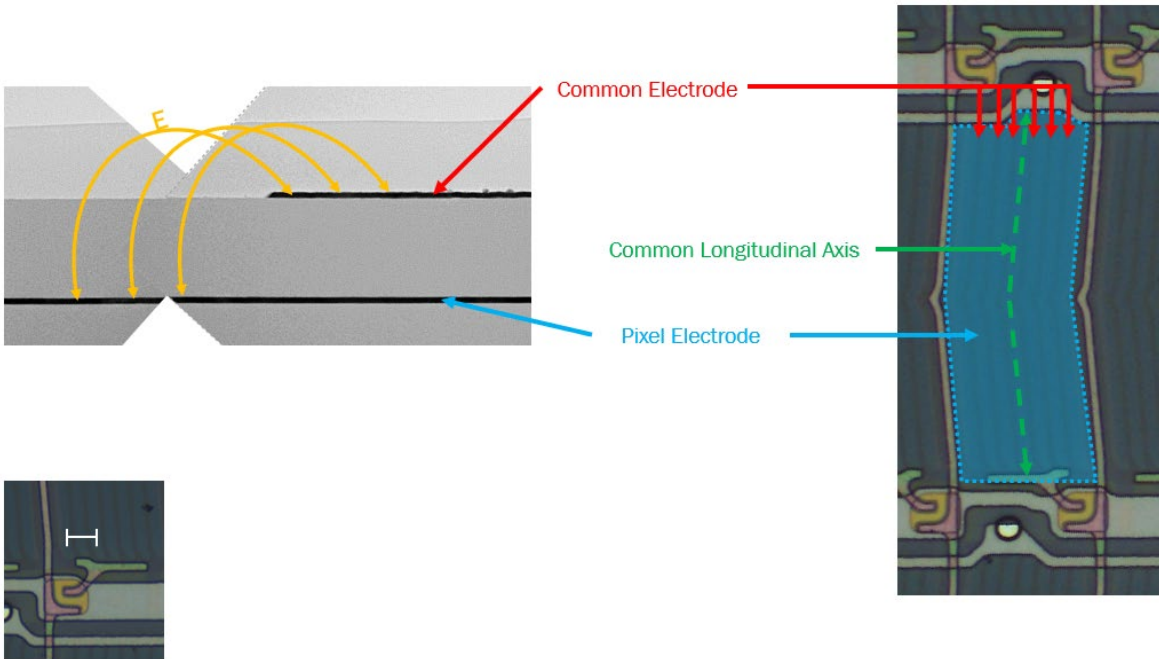

49. In the Accused LCD Product, as shown below, the liquid crystal layer has non-zero initial alignment angles relative to the common longitudinal axis and alignment of the first part of the liquid crystal layer does not change when an electric field is generated between the source and drain electrodes.

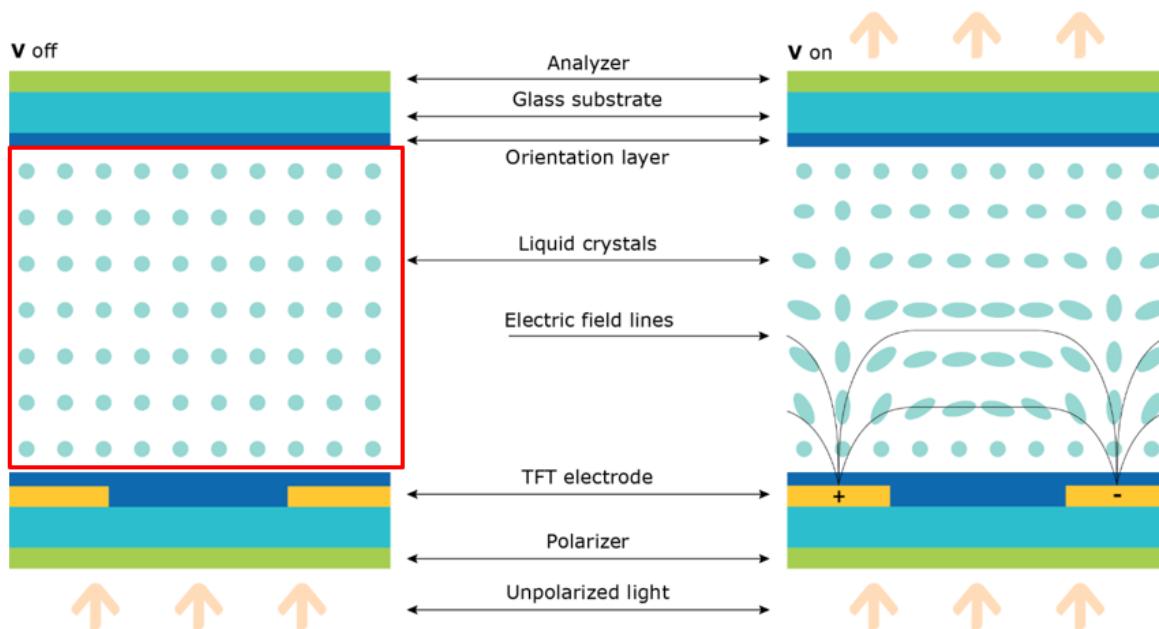

<https://www.emdgroup.com/en/expertise/displays/solutions/liquid-crystals/lcd-technologies/ips.html>

50. The Accused LCD Product has a thin film transistor (TFT) with a source electrode and a drain electrode adjacent to a part of the liquid crystal layer, as shown below. The electric field generated by the source and drain electrodes is substantially parallel to the non-zero initial alignment angle.

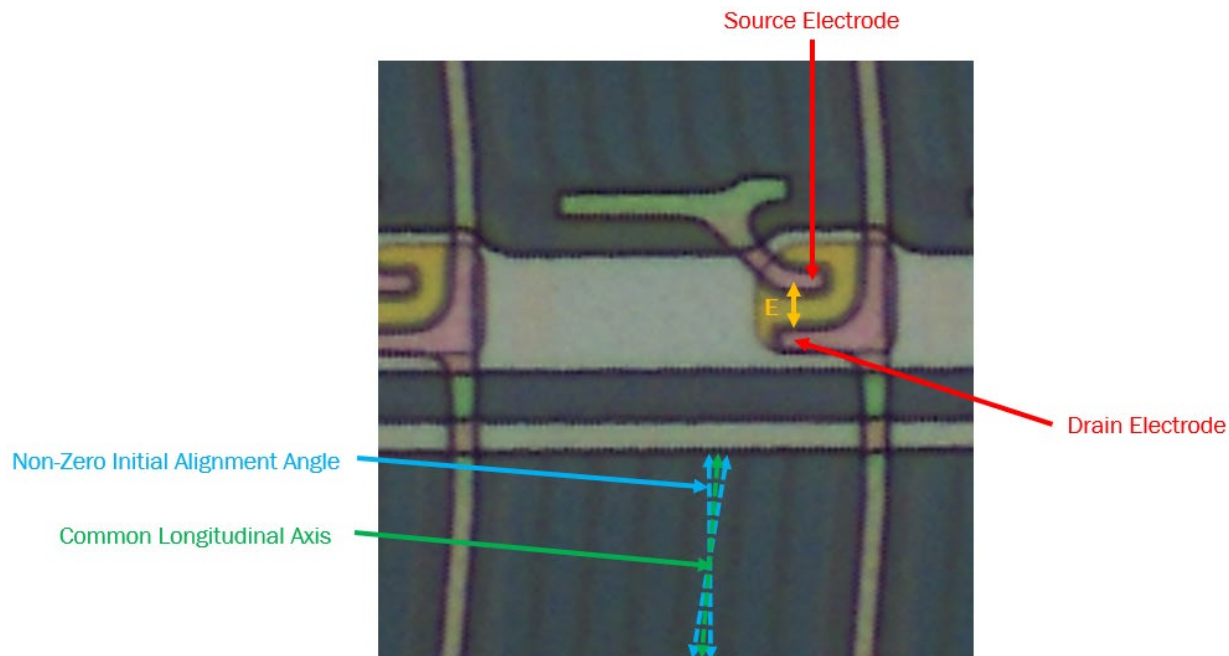

51. The Accused LCD Product also has common electrodes, as shown below, extending substantially parallel to the scanning lines and with comb-tooth projections extending toward the scanning lines.

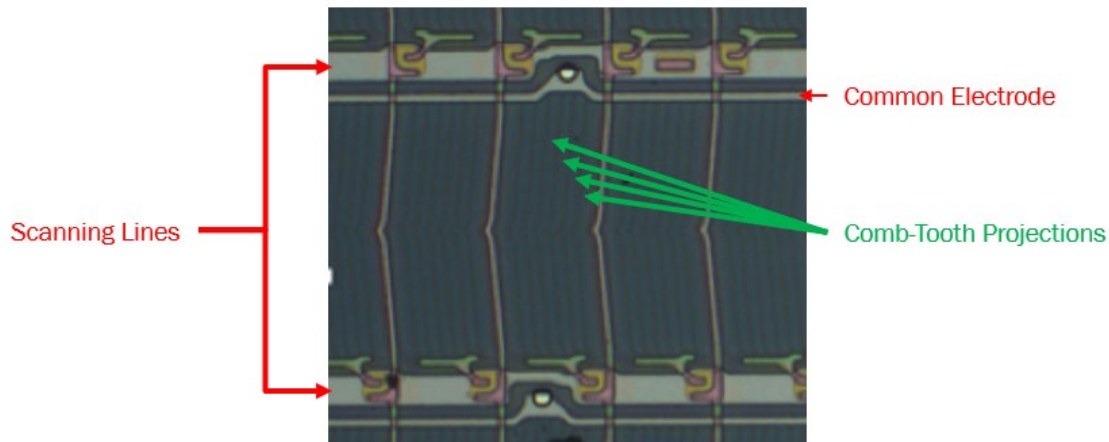

52. As shown below, the Accused LCD Product has pixel electrodes that are substantially parallel to the comb-tooth projections and located in gaps between comb-tooth projections.

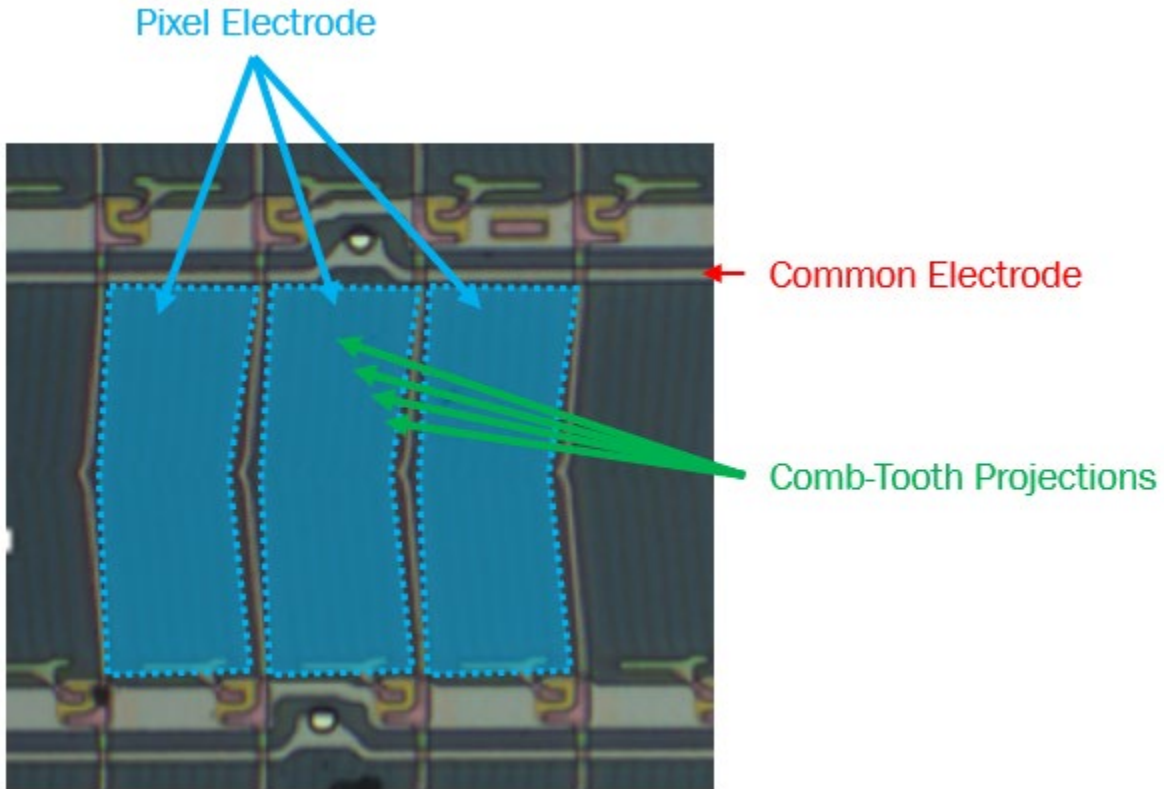

53. As shown below, in the Accused LCD Product, at least a portion of each pixel electrode is opposite to a common electrode and interposed by an interlayer insulating film. The interlayer insulating film is disposed between the common electrodes and the pixel electrodes.

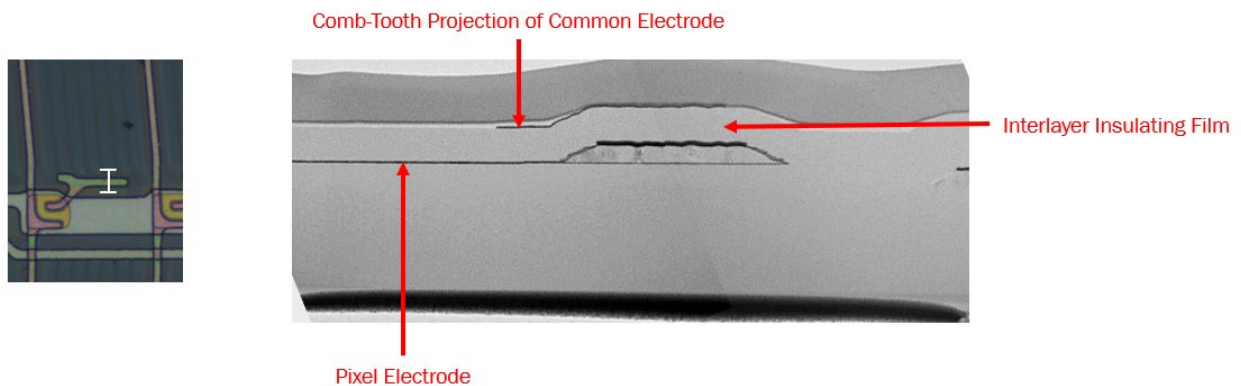

54. As shown below, in the Accused LCD Product, an alignment film and a protective insulating film are present above the pixel electrode.

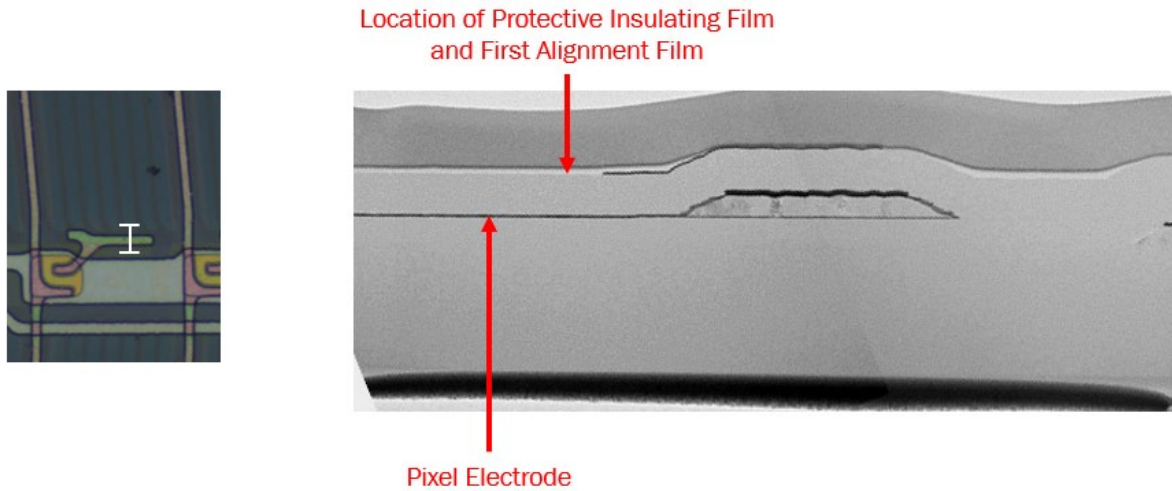

55. The Accused LCD Product has a second substrate with a black matrix with opening in areas opposite to the pixel electrodes, as shown below.

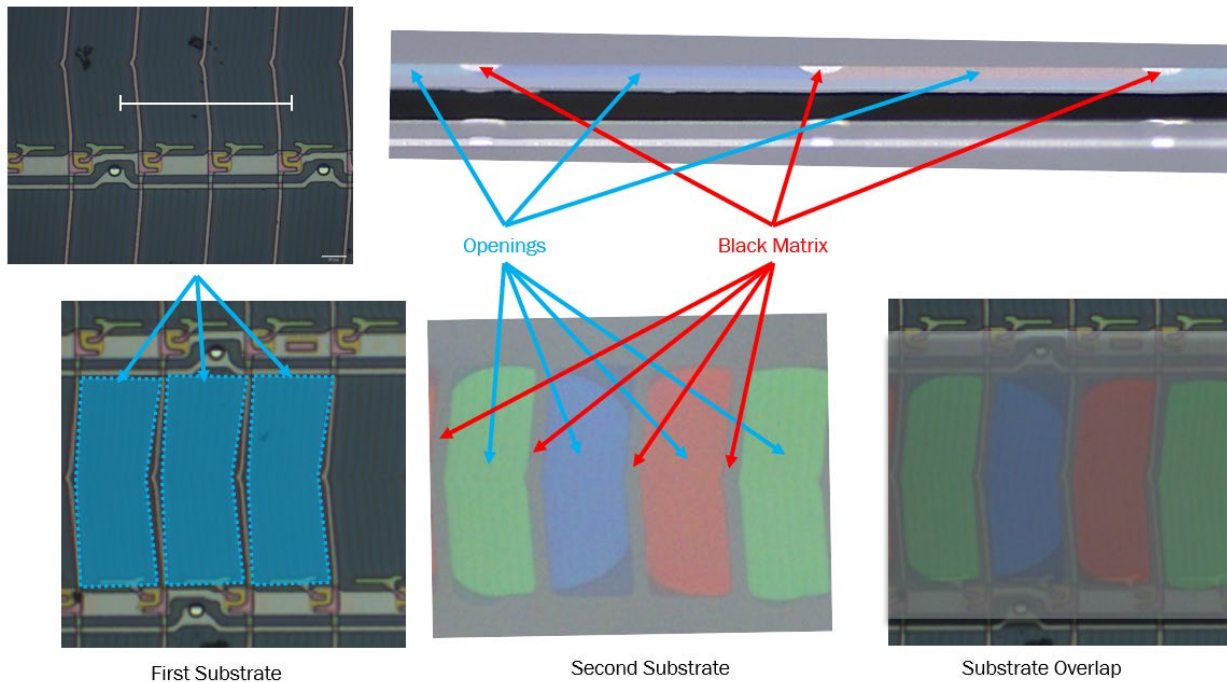

56. The Accused LCD Product has a second alignment film on the color filter substrate, as shown below.

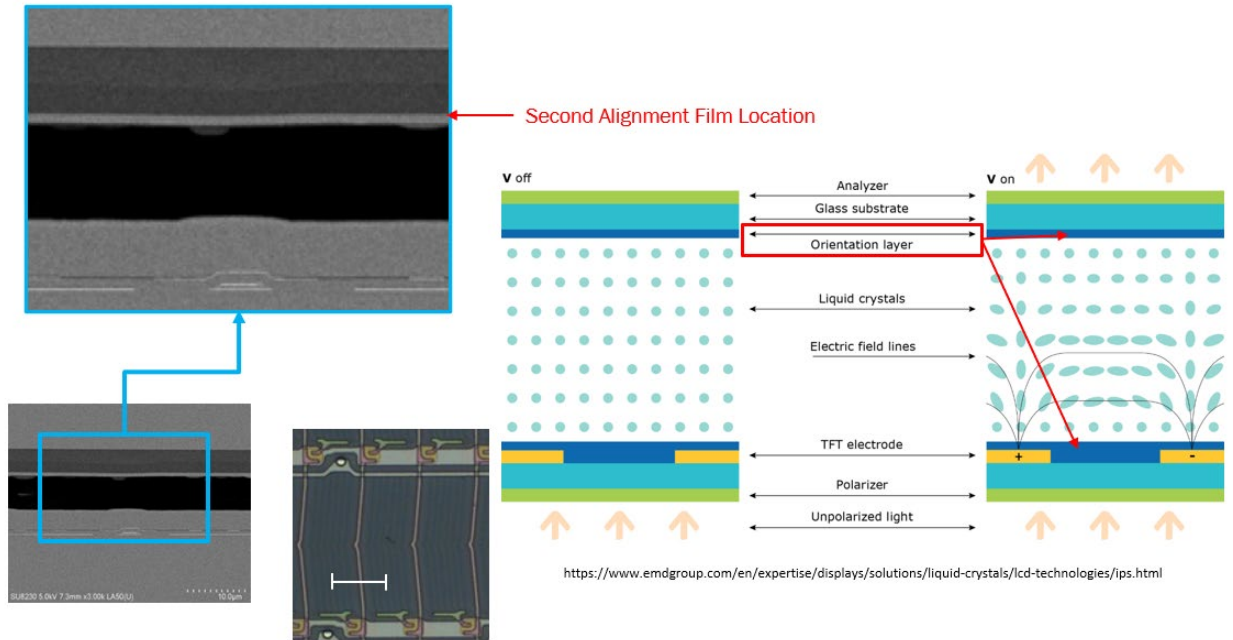

57. The Accused LCD Product has an accumulated capacitance increasing means (e.g., dielectric between the pixel electrode and comb-tooth projections of a common electrode), as shown below.

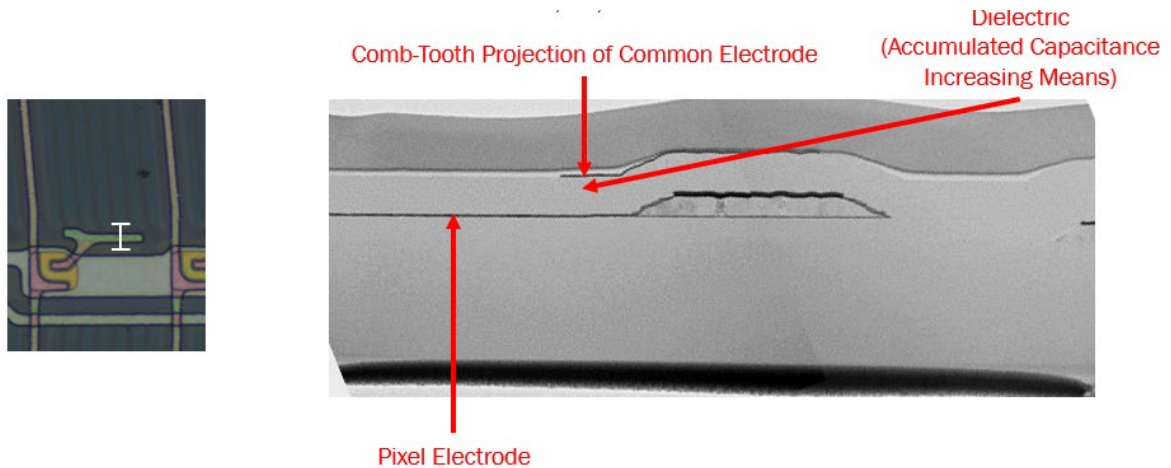

58. The Accused LCD Product has an active matrix type liquid crystal display device with an array substrate having a switching element array, an opposing substrate, and a liquid layer in between, as illustrated below in reference to K&D Technology LCD Model No. KD101N37-40NA-A10, shown below.

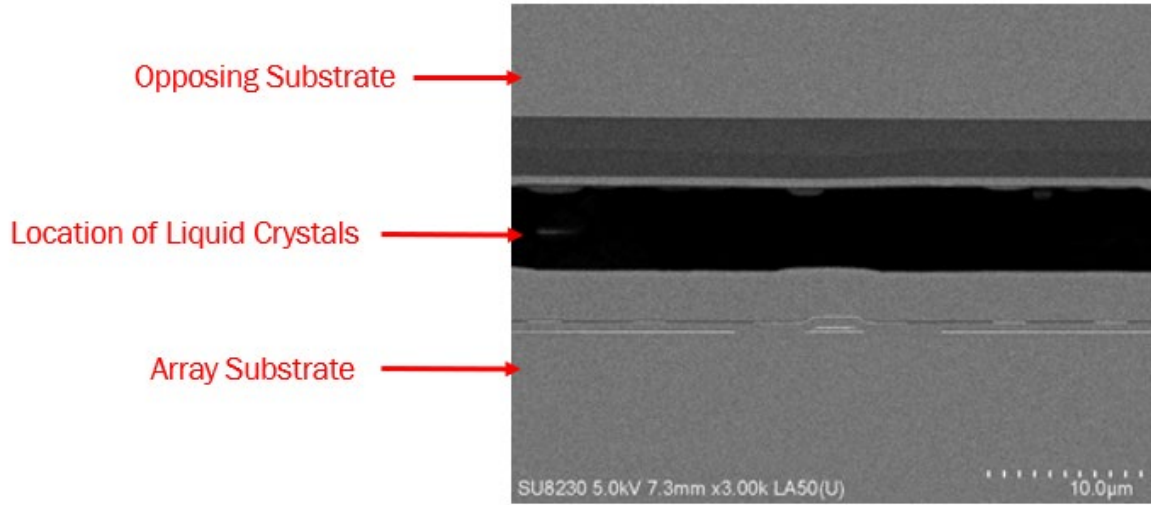
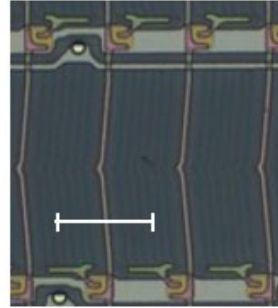

59. The Accused LCD Product has a seal across its periphery, as shown below.

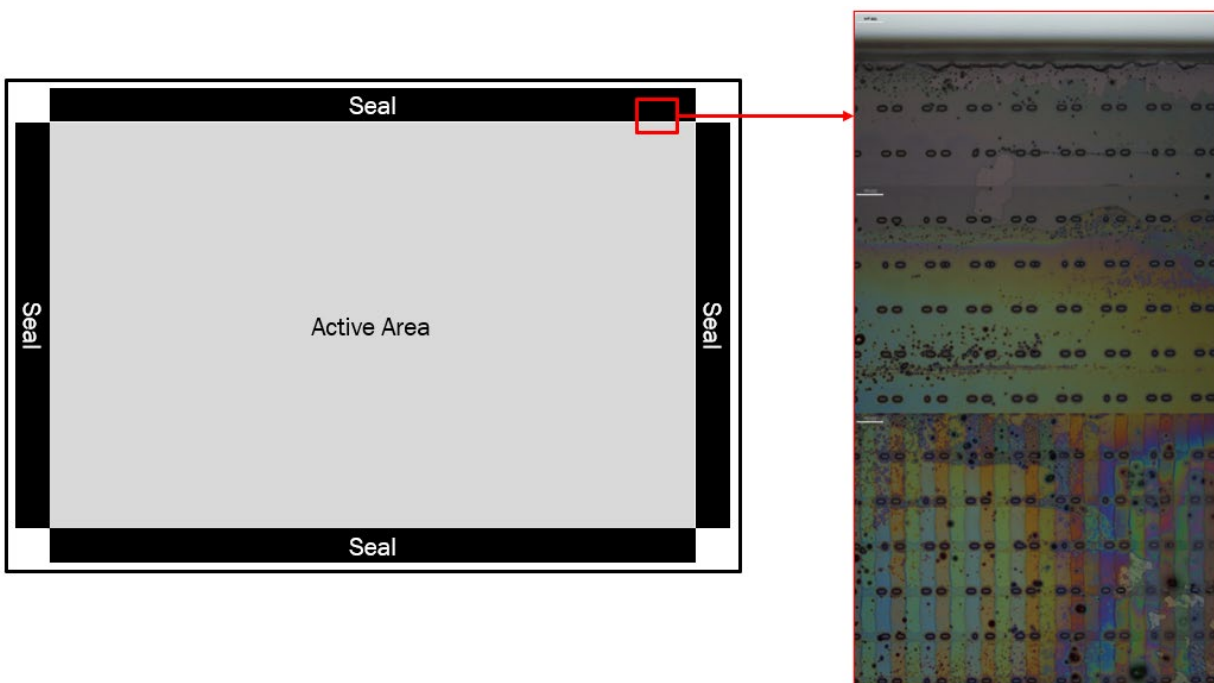

60. The Accused LCD Product has a spacer in the seal to make a gap between the array substrate and the opposing substrate constant, as shown below.

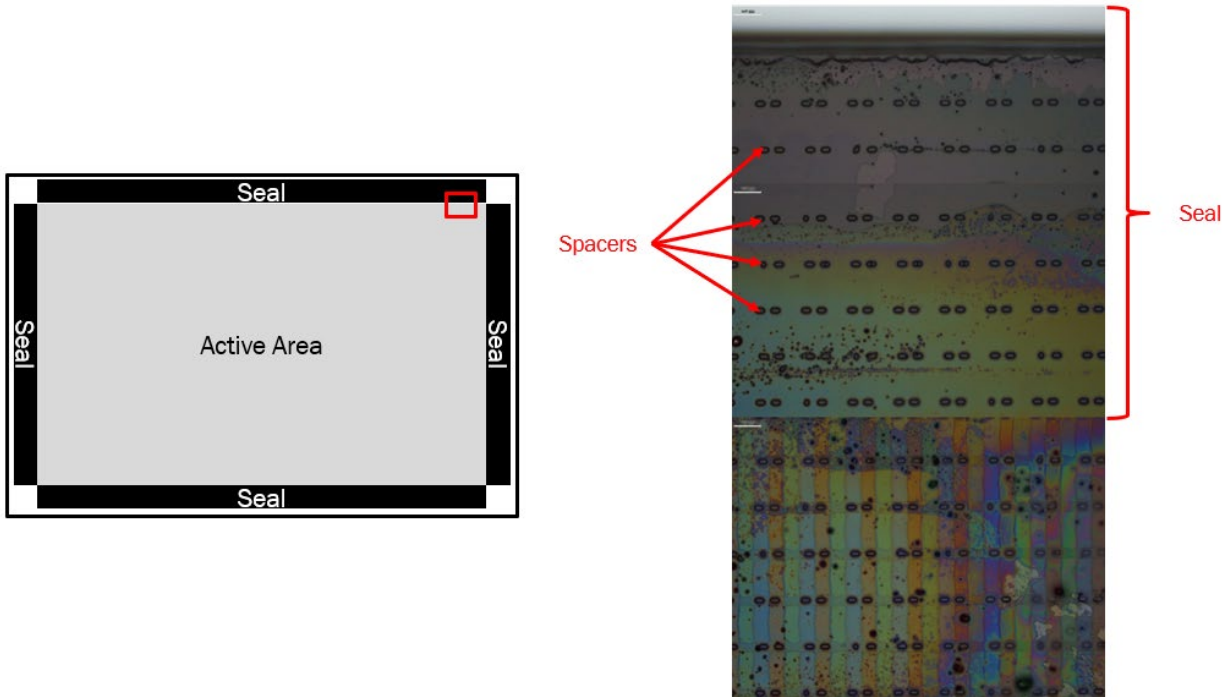

61. The Accused LCD Product has a leveling layer formed on the switching element array. As shown below, the leveling layer has an opening area and a thin region at the seal.

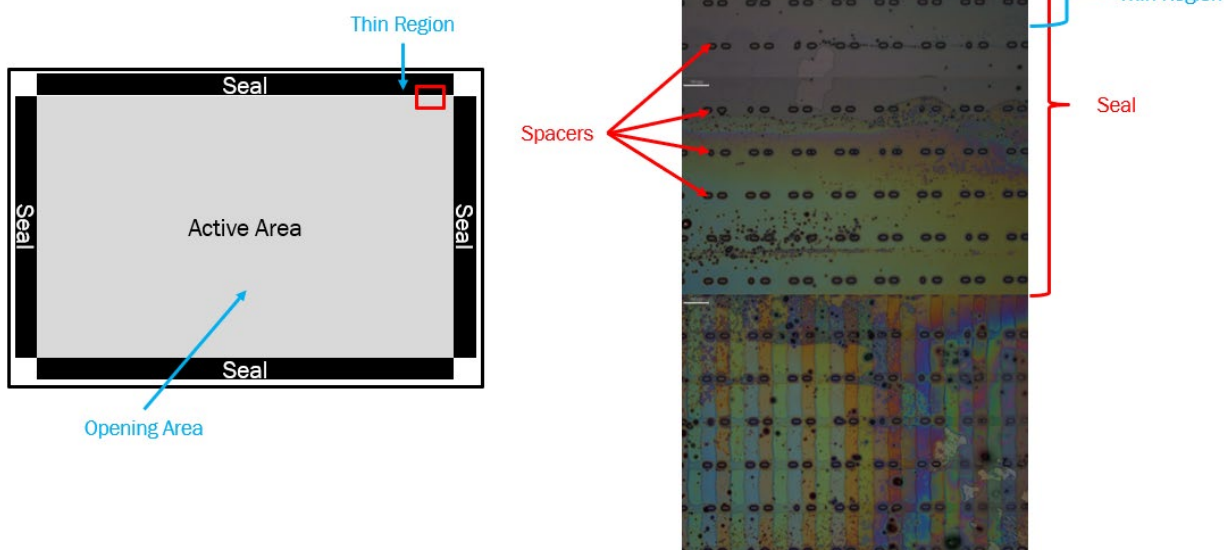

62. The Asserted Patents also cover Accused LCD Products that include, as shown below, a surge protection circuit having a plurality of horizontal signal lines (e.g., gate lines) intersecting the vertical lines (e.g., drain bus lines).

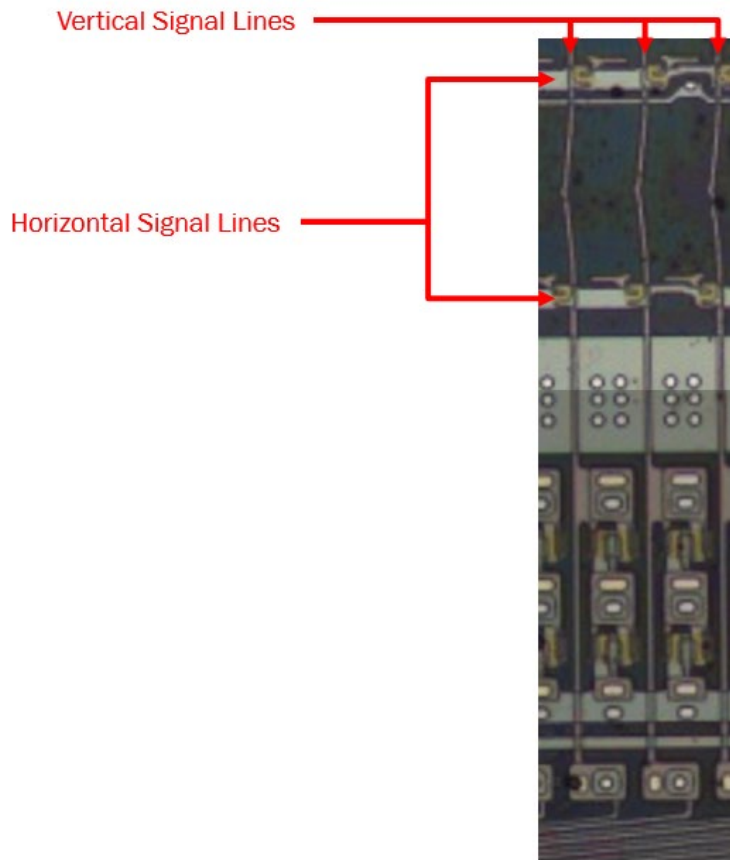

63. The surge protection circuit referenced above also includes a plurality of floating-gate field effect transistors, each having a channel capacitance and including a floating gate electrode, a source electrode, and a drain electrode. The source and drain electrodes of the transistors are connected to the vertical signal lines, as shown below.

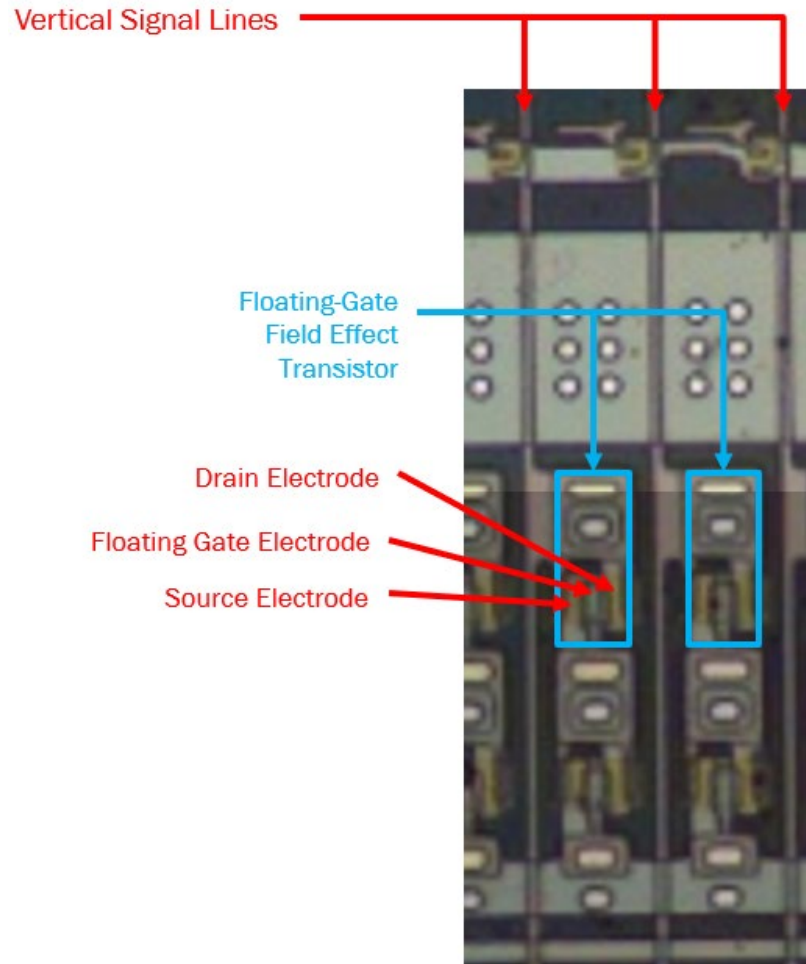

64. As shown below, the transistors respond to surge potentials on the vertical signal lines by turning on and establishing a low-impedance path to ground.

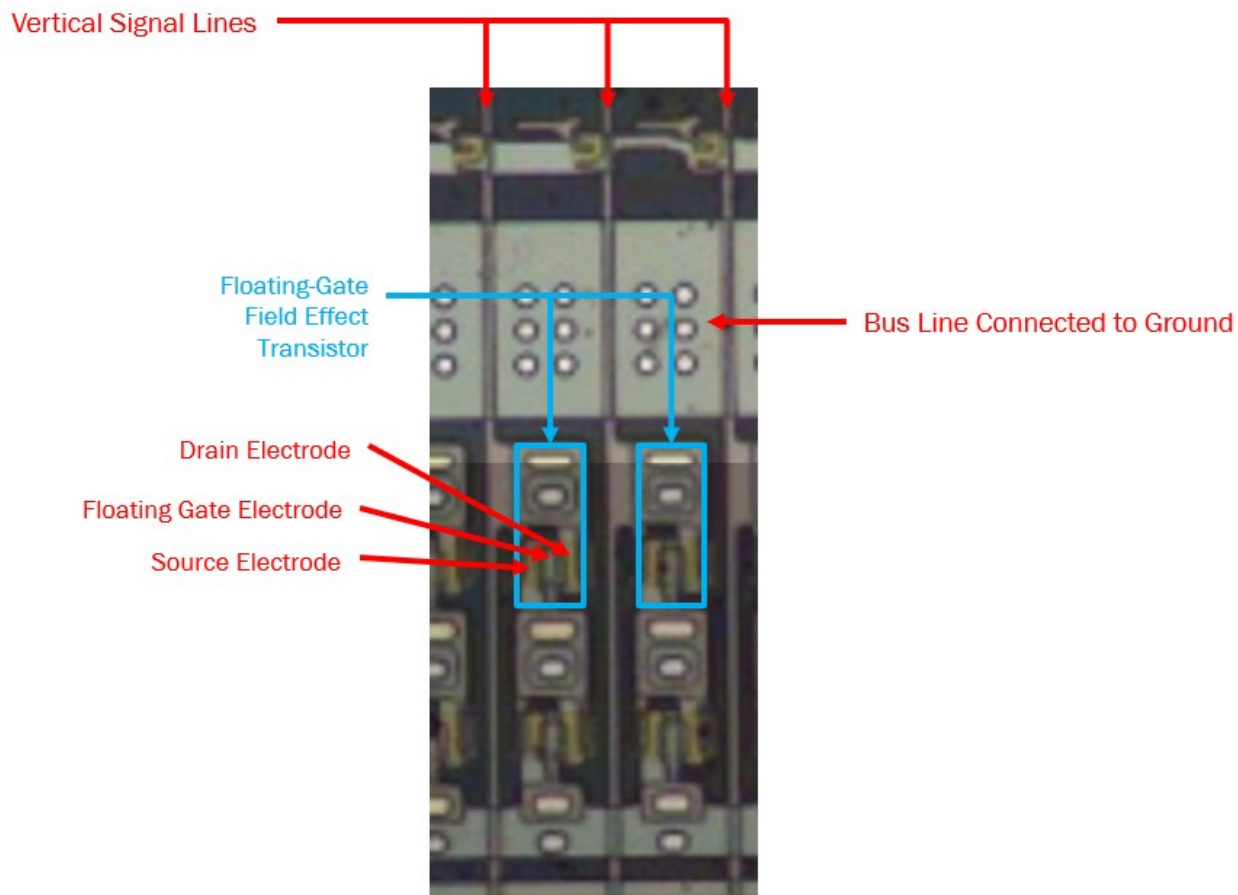

65. The Asserted Patents cover Accused LCD Products that have a frame surrounding an opening, as shown below with respect to the K&D Technology LCD Model No. KD101N37-40NA-A10 in the Acer Iconia One 10. A light conductive plate (LCP) is positioned in the opening of the frame, which has surfaces adjacent to the two frame surfaces, as shown below. A diffusion sheet is fastened to the first surface of the frame and covers at least a portion of the first surfaces of the frame and light conductive plate, as shown below.

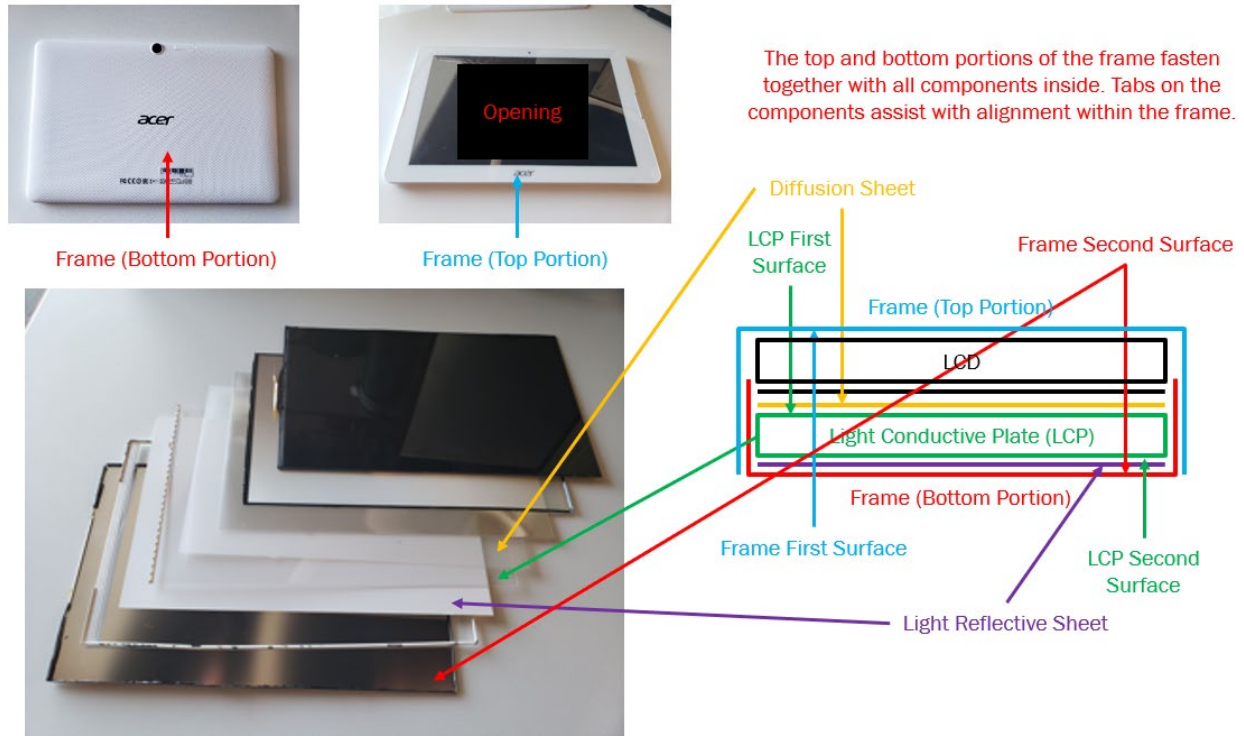

66. In the above-referenced product, the diffusion sheet and the light reflective sheet cooperate to fasten the light conductive plate within the frame, as shown below.

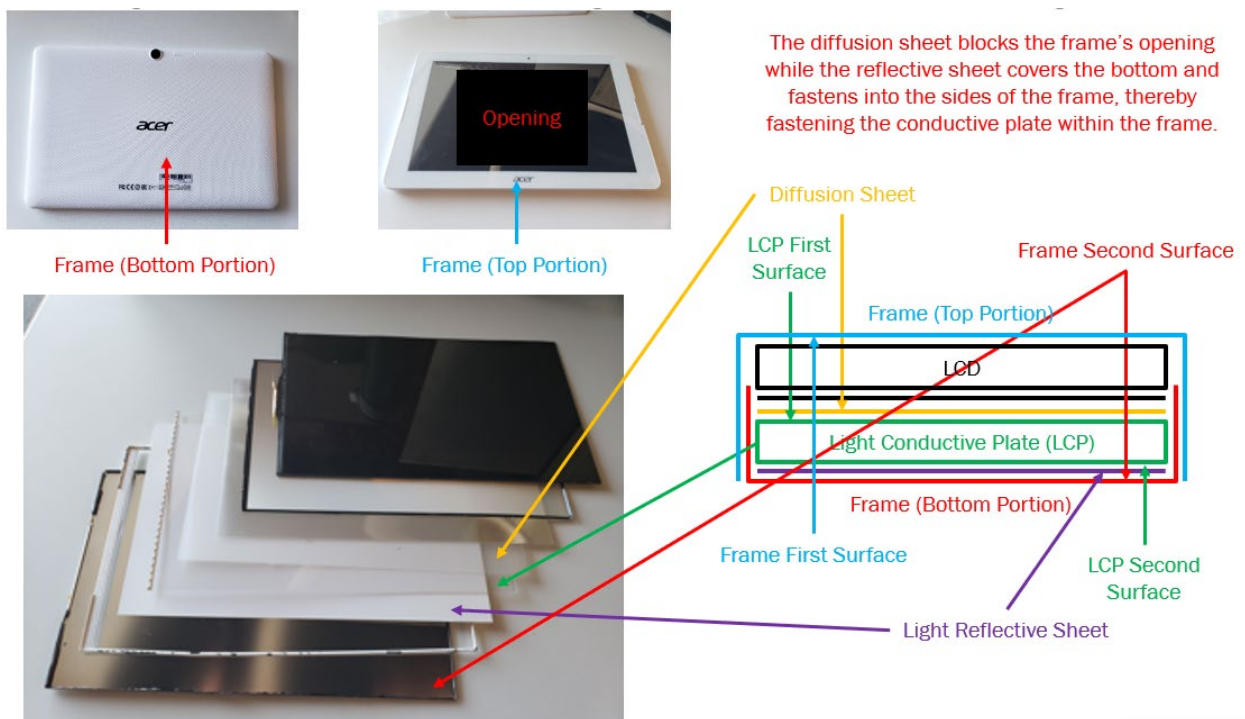

COUNT I

(INFRINGEMENT OF U.S. PATENT NO. 6,579,749)

67. Plaintiff incorporates paragraphs 1 through 66 herein by reference.

68. VPV is the assignee of the '749 patent, entitled "Fabrication method and fabrication apparatus for thin film transistor," with ownership of all substantial rights in the '749 patent, including the right to exclude others and to enforce, sue, and recover damages for past and future infringements.

69. The '749 patent is valid, enforceable, and was duly issued in full compliance with Title 35 of the United States Code. The '749 patent issued from U.S. Patent Application No. 09/440,615.

70. Defendants have and continue to directly and/or indirectly infringe (by inducing infringement) one or more claims of the '749 patent in this judicial district and elsewhere in Texas and the United States.

71. Upon information and belief, Defendant K&D conducts research and development, manufactures, and sells TFT-LCD products, including panels and related components. These products are incorporated into electronic devices such as tablets, including tablets manufactured by and sold in the U.S. Defendant K&D further manufactures infringing TFT-LCD panels and related components on behalf of and for the benefit of the Acer Group Defendants. These panels and related components are incorporated into electronic devices manufactured by the Acer Group Defendants, which are marketed and sold under at least the Acer brand.

72. Upon information and belief, the Acer Group Defendants conduct research and development, manufacture, and sell electronic devices, including tablets marketed and sold under the Acer brand in the United States. These electronic devices of the Acer Group Defendants incorporate infringing TFT-LCD panels and related components (including those manufactured by

Defendant K&D), device housings, backlight modules, display controllers, and processes related to the same.

73. Defendants directly infringe the '749 patent via 35 U.S.C. § 271(a) by making, offering for sale, selling, and/or importing Accused LCD Products, their components, and/or products containing same that incorporate the fundamental technologies covered by the '749 patent to, for example, alter egos, agents, intermediaries, distributors, importers, customers, subsidiaries, and/or consumers. Furthermore, upon information and belief, Defendants sell and make Accused LCD Products outside of the United States, deliver those products to their alter egos, agents, intermediaries, distributors, importers, customers, subsidiaries, and/or consumers in the United States, or in the case that Defendants deliver the Accused LCD Products outside of the United States, Defendants do so intending and/or knowing that those panels are destined for the United States and/or designing those products for sale in the United States, thereby directly infringing the '749 patent. *See, e.g., Lake Cherokee Hard Drive Techs., L.L.C. v. Marvell Semiconductor, Inc.*, 964 F. Supp. 2d 653, 658 (E.D. Tex. 2013).

74. Defendant K&D directly infringes the '749 patent through its direct involvement in the activities of Acer conducted on behalf of and for the benefit of Defendant K&D. Such direct infringement includes selling and offering for sale the Accused LCD Products directly to Acer. Upon information and belief, Defendant K&D conducts activities that constitute direct infringement of the '749 patent under 35 U.S.C. § 271(a) by making, offering for sale, selling, and/or importing those Accused LCD Products.

75. The Acer Group Defendants directly infringe the '749 patent through their direct involvement in the activities of their U.S.-based subsidiaries, including, but not limited to, Acer America, conducted on behalf of and for the benefit of the Acer Group Defendants. Such direct

infringement includes selling and offering for sale the Accused LCD Products directly to Acer America and importing the Accused LCD Products into the United States for the Acer Group Defendants. Upon information and belief, the Acer Group Defendants conduct activities that constitute direct infringement of the '749 patent under 35 U.S.C. § 271(a) by making, offering for sale, selling, and/or importing those Accused LCD Products. The Acer Group Defendants are vicariously liable for the infringing conduct of Acer America (under both the alter ego and agency theories). As an example and upon information and belief, the Acer Group Defendants and their including Acer America, are essentially the same company, and the Acer Group Defendants have the right and ability to control their associates' and subsidiaries' infringing acts (including those of Acer America) and receive a direct financial benefit from that infringement.

76. For example, Defendants infringe claim 13 of the '749 patent via K&D Technology LCD Model No. KD101N37-40NA-A10 incorporated into the Acer Iconia One 10. That Accused LCD Product is made by K&D pursuant to a "method for fabricating a semiconductor device, comprising the steps of" each of the limitations of claim 1. The technology discussion above and the example Accused LCD Product provide context for Plaintiff's allegations that each of those limitations are met. For example, the Accused LCD Product includes semiconductor devices made pursuant to a first step of forming an amorphous silicon film on a substrate; and a second step of performing plasma processing with respect to said substrate having said amorphous silicon film formed thereon, said plasma containing an n-type impurity element selected from a group V of a periodic table to provide an n-type region in the top surface of the amorphous silicon film; and then directly a third step of forming a metal film on said amorphous silicon film to form an n-type amorphous silicon film therebetween.

77. Defendants further infringe the '749 patent via 35 U.S.C. § 271(g) by selling, offering to sell, and/or importing Accused LCD Products, their components, and/or products containing same, that are made by a process covered by the '749 patent. Upon information and belief, the Accused LCD Products, their components, and/or products containing same are not materially changed by subsequent processes, and they are neither trivial nor nonessential components of another product.

78. Defendants further infringe based on the importation, sale, offer for sale, or use of the Accused LCD Products that are made from a process covered by the '749 patent. To the extent that Plaintiff made reasonable efforts to determine whether the patent processes of the '749 patent were used in the production of the Accused LCD Products but was not able to so determine, the Accused LCD Products should be presumed by this Court to have been so made, pursuant to 35 U.S.C. § 295.

79. At a minimum, Defendants have known of the '749 patent at least as early as the filing date of the complaint. In addition, K&D has known about the '749 patent since at least the receipt of a March 26, 2020 letter addressed to its General Counsel of Shenzhen K&D Technology Co., Ltd. that identified each Asserted Patent, except for the '070 patent, and how each patent was infringed by three LCDs from Acer Tablets. In addition, Acer America has known about the '749 patent since at least its August 19, 2020 receipt of a letter addressed to its General Counsel identifying all eight Asserted Patents and how they were infringed by Acer Iconia tablets. In addition, Acer Inc. has known about the '749 patent since at least its August 24, 2020 receipt of a letter addressed to its General Counsel identifying all eight Asserted Patents and how they were infringed by Acer Iconia tablets. In addition, emails were sent to Peggy.Yo@acer.com and

Kate.Ci.Shang@acer.com on September 8, 2020 with access to information containing evidence of use for all eight Asserted Patents.

80. Upon information and belief, since at least the above-mentioned date when Defendants were on notice of their infringement, Defendants have actively induced, under U.S.C. § 271(b), distributors, customers, subsidiaries, importers, and/or consumers that import, purchase, or sell the Accused LCD Products that include or are made using all of the limitations of one or more claims of the '749 patent to directly infringe one or more claims of the '749 patent by using, offering for sale, selling, and/or importing the Accused LCD Products. Since at least the notice provided on the above-mentioned date, Defendants do so with knowledge, or with willful blindness of the fact, that the induced acts constitute infringement of the '749 patent. Upon information and belief, Defendants intend to cause, and have taken affirmative steps to induce infringement by distributors, importers (including inducement to import in violation of § 271(g)), customers, subsidiaries, and/or consumers by, inter alia, creating advertisements that promote the infringing use of the Accused LCD Products, creating established distribution channels for the Accused LCD Products into and within the United States, manufacturing the Accused LCD Products in conformity with U.S. laws and regulations, distributing or making available instructions or manuals for these products to purchasers and prospective buyers, and/or providing technical support, replacement parts, or services for these products to these purchasers in the United States.

81. Upon information and belief, despite having knowledge of the '749 patent and knowledge that it is directly and/or indirectly infringing one or more claims of the '749 patent, Defendants have nevertheless continued their infringing conduct and disregarded an objectively high likelihood of infringement. Defendants' infringing activities relative to the '749 patent have been, and continue to be, willful, wanton, malicious, in bad-faith, deliberate, consciously wrongful,

flagrant, characteristic of a pirate, and an egregious case of misconduct beyond typical infringement such that Plaintiff is entitled under 35 U.S.C. § 284 to enhanced damages up to three times the amount found or assessed.

82. VPV has been damaged as a result of Defendants' infringing conduct described in this Count. Defendants are, thus, liable to VPV in an amount that adequately compensates VPV for Defendants' infringements, which, by law, cannot be less than a reasonable royalty, together with interest and costs as fixed by this Court under 35 U.S.C. § 284.

COUNT II

(INFRINGEMENT OF U.S. PATENT NO. 7,499,119)

83. Plaintiff incorporates paragraphs 1 through 82 herein by reference.

84. VPV is the assignee of the '119 patent, entitled "Liquid crystal display device with thin-film transistors and method of fabricating the same," with ownership of all substantial rights in the '119 patent, including the right to exclude others and to enforce, sue, and recover damages for past and future infringements.

85. The '119 patent is valid, enforceable, and was duly issued in full compliance with Title 35 of the United States Code. The '119 patent issued from U.S. Patent Application No. 11/582,315.

86. Defendants have and continue to directly and/or indirectly infringe (by inducing infringement) one or more claims of the '119 patent in this judicial district and elsewhere in Texas and the United States.

87. Upon information and belief, Defendant K&D conducts research and development, manufactures, and sells TFT-LCD products, including panels and related components. These products are incorporated into electronic devices such as tablets, including tablets manufactured by and sold in the U.S. Defendant K&D further manufactures infringing TFT-LCD panels and

related components on behalf of and for the benefit of the Acer Group Defendants. These panels and related components are incorporated into electronic devices manufactured by the Acer Group Defendants, which are marketed and sold under at least the Acer brand.

88. Upon information and belief, the Acer Group Defendants conduct research and development, manufacture, and sell electronic devices, including tablets marketed and sold under the Acer brand in the United States. These electronic devices of the Acer Group Defendants incorporate infringing TFT-LCD panels and related components (including those manufactured by Defendant K&D), device housings, backlight modules, display controllers, and processes related to the same.

89. Defendants directly infringe the '119 patent via 35 U.S.C. § 271(a) by making, offering for sale, selling, and/or importing Accused LCD Products, their components, and/or products containing same that incorporate the fundamental technologies covered by the '119 patent to, for example, alter egos, agents, intermediaries, distributors, importers, customers, subsidiaries, and/or consumers. Furthermore, upon information and belief, Defendants sell and make Accused LCD Products outside of the United States, deliver those products to their alter egos, agents, intermediaries, distributors, importers, customers, subsidiaries, and/or consumers in the United States, or in the case that Defendants deliver the Accused LCD Products outside of the United States, Defendants do so intending and/or knowing that those panels are destined for the United States and/or designing those products for sale in the United States, thereby directly infringing the '119 patent. *See, e.g., Lake Cherokee Hard Drive Techs., L.L.C. v. Marvell Semiconductor, Inc.*, 964 F. Supp. 2d 653, 658 (E.D. Tex. 2013).

90. Defendant K&D directly infringes the '119 patent through its direct involvement in the activities of Acer conducted on behalf of and for the benefit of Defendant K&D. Such direct

infringement includes selling and offering for sale the Accused LCD Products directly to Acer. Upon information and belief, Defendant K&D conducts activities that constitute direct infringement of the '119 patent under 35 U.S.C. § 271(a) by making, offering for sale, selling, and/or importing those Accused LCD Products.

91. The Acer Group Defendants directly infringe the '119 patent through their direct involvement in the activities of their U.S.-based subsidiaries, including, but not limited to, Acer America, conducted on behalf of and for the benefit of the Acer Group Defendants. Such direct infringement includes selling and offering for sale the Accused LCD Products directly to Acer America and importing the Accused LCD Products into the United States for the Acer Group Defendants. Upon information and belief, the Acer Group Defendants conduct activities that constitute direct infringement of the '119 patent under 35 U.S.C. § 271(a) by making, offering for sale, selling, and/or importing those Accused LCD Products. The Acer Group Defendants are vicariously liable for the infringing conduct of Acer America (under both the alter ego and agency theories). As an example and upon information and belief, the Acer Group Defendants and their including Acer America, are essentially the same company, and the Acer Group Defendants have the right and ability to control their associates' and subsidiaries' infringing acts (including those of Acer America) and receive a direct financial benefit from that infringement.

92. For example, Defendants infringe claim 1 of the '119 patent via K&D Technology LCD Model No. KD101N37-40NA-A10 incorporated into the Acer Iconia One 10. The Accused LCD Product includes a "liquid-crystal display device comprising" each of the limitations of claim 1. The technology discussion above and the example Accused LCD Products provide context for Plaintiff's allegations that each of those limitations are met. For example, the Accused LCD Products include a first interconnection line comprising a patterned Al or Al alloy layer, disposed

directly on an insulating plate or over the plate by way of an underlying insulating layer: a first insulating layer formed on the plate to cover the first interconnection line, the first insulating layer having a contact hole that exposes a part of the first interconnection line; a first conductive material made of a plated metal, the first conductive material being in contact with the exposed part of the first interconnection line in the contact hole in such a way as to cover the whole exposed part thereof; and a first transparent conductive layer in contact with the first conductive material; wherein the first transparent conductive layer is electrically connected to the first interconnection line by way of the first conductive material.

93. At a minimum, Defendants have known of the '119 patent at least as early as the filing date of the complaint. In addition, K&D has known about the '119 patent since at least the receipt of a March 26, 2020 letter addressed to its General Counsel of Shenzhen K&D Technology Co., Ltd. that identified each Asserted Patent, except for the '070 patent, and how each patent was infringed by three LCDs from Acer Tablets. In addition, Acer America has known about the '119 patent since at least its August 19, 2020 receipt of a letter addressed to its General Counsel identifying all eight Asserted Patents and how they were infringed by Acer Iconia tablets. In addition, Acer Inc. has known about the '119 patent since at least its August 24, 2020 receipt of a letter addressed to its General Counsel identifying all eight Asserted Patents and how they were infringed by Acer Iconia tablets. In addition, emails were sent to Peggy.Yo@acer.com and Kate.Ci.Shang@acer.com on September 8, 2020 with access to information containing evidence of use for all eight Asserted Patents.

94. Upon information and belief, since at least the above-mentioned date when Defendants were on notice of their infringement, Defendants have actively induced, under U.S.C. § 271(b), distributors, customers, subsidiaries, importers, and/or consumers that import, purchase,

or sell the Accused LCD Products that include or are made using all of the limitations of one or more claims of the '119 patent to directly infringe one or more claims of the '119 patent by using, offering for sale, selling, and/or importing the Accused LCD Products. Since at least the notice provided on the above-mentioned date, Defendants do so with knowledge, or with willful blindness of the fact, that the induced acts constitute infringement of the '119 patent. Upon information and belief, Defendants intend to cause, and have taken affirmative steps to induce infringement by distributors, importers (including inducement to import in violation of § 271(g)), customers, subsidiaries, and/or consumers by, inter alia, creating advertisements that promote the infringing use of the Accused LCD Products, creating established distribution channels for the Accused LCD Products into and within the United States, manufacturing the Accused LCD Products in conformity with U.S. laws and regulations, distributing or making available instructions or manuals for these products to purchasers and prospective buyers, and/or providing technical support, replacement parts, or services for these products to these purchasers in the United States..

95. Upon information and belief, despite having knowledge of the '119 patent and knowledge that it is directly and/or indirectly infringing one or more claims of the '119 patent, Defendants have nevertheless continued their infringing conduct and disregarded an objectively high likelihood of infringement. Defendants' infringing activities relative to the '119 patent have been, and continue to be, willful, wanton, malicious, in bad-faith, deliberate, consciously wrongful, flagrant, characteristic of a pirate, and an egregious case of misconduct beyond typical infringement such that Plaintiff is entitled under 35 U.S.C. § 284 to enhanced damages up to three times the amount found or assessed.

96. Plaintiff has been damaged as a result of Defendants' infringing conduct described in this Count. Defendants are, thus, liable to Plaintiff in an amount that adequately compensates

Plaintiff for Defendants' infringements, which, by law, cannot be less than a reasonable royalty, together with interest and costs as fixed by this Court under 35 U.S.C. § 284.

COUNT III

(INFRINGEMENT OF U.S. PATENT NO. 6,404,474)

97. Plaintiff incorporates paragraphs 1 through 96 herein by reference.

98. Plaintiff is the assignee of the '474 patent, entitled "Horizontal electric field LCD with increased capacitance between pixel and common electrodes," with ownership of all substantial rights in the '474 patent, including the right to exclude others and to enforce, sue, and recover damages for past and future infringements.

99. The '474 patent is valid, enforceable, and was duly issued in full compliance with Title 35 of the United States Code. The '474 patent issued from U.S. Patent Application No. 09/357,060.

100. Defendants have and continue to directly and/or indirectly infringe (by inducing infringement) one or more claims of the '474 patent in this judicial district and elsewhere in Texas and the United States.

101. Upon information and belief, Defendant K&D conducts research and development, manufactures, and sells TFT-LCD products, including panels and related components. These products are incorporated into electronic devices such as tablets, including tablets manufactured by and sold in the U.S. Defendant K&D further manufactures infringing TFT-LCD panels and related components on behalf of and for the benefit of the Acer Group Defendants. These panels and related components are incorporated into electronic devices manufactured by the Acer Group Defendants, which are marketed and sold under at least the Acer brand.

102. Upon information and belief, the Acer Group Defendants conduct research and development, manufacture, and sell electronic devices, including tablets marketed and sold under

the Acer brand in the United States. These electronic devices of the Acer Group Defendants incorporate infringing TFT-LCD panels and related components (including those manufactured by Defendant K&D), device housings, backlight modules, display controllers, and processes related to the same.

103. Defendants directly infringe the '474 patent via 35 U.S.C. § 271(a) by making, offering for sale, selling, and/or importing Accused LCD Products, their components, and/or products containing same that incorporate the fundamental technologies covered by the '474 patent to, for example, alter egos, agents, intermediaries, distributors, importers, customers, subsidiaries, and/or consumers. Furthermore, upon information and belief, Defendants sell and make Accused LCD Products outside of the United States, deliver those products to their alter egos, agents, intermediaries, distributors, importers, customers, subsidiaries, and/or consumers in the United States, or in the case that Defendants deliver the Accused LCD Products outside of the United States, Defendants do so intending and/or knowing that those panels are destined for the United States and/or designing those products for sale in the United States, thereby directly infringing the '474 patent. *See, e.g., Lake Cherokee Hard Drive Techs., L.L.C. v. Marvell Semiconductor, Inc.*, 964 F. Supp.2d 653, 658 (E.D. Tex. 2013).

104. Defendant K&D directly infringes the '474 patent through its direct involvement in the activities of Acer conducted on behalf of and for the benefit of Defendant K&D. Such direct infringement includes selling and offering for sale the Accused LCD Products directly to Acer. Upon information and belief, Defendant K&D conducts activities that constitute direct infringement of the '474 patent under 35 U.S.C. § 271(a) by making, offering for sale, selling, and/or importing those Accused LCD Products.

105. The Acer Group Defendants directly infringe the '474 patent through their direct involvement in the activities of their U.S.-based subsidiaries, including, but not limited to, Acer America, conducted on behalf of and for the benefit of the Acer Group Defendants. Such direct infringement includes selling and offering for sale the Accused LCD Products directly to Acer America and importing the Accused LCD Products into the United States for the Acer Group Defendants. Upon information and belief, the Acer Group Defendants conduct activities that constitute direct infringement of the '474 patent under 35 U.S.C. § 271(a) by making, offering for sale, selling, and/or importing those Accused LCD Products. The Acer Group Defendants are vicariously liable for the infringing conduct of Acer America (under both the alter ego and agency theories). As an example and upon information and belief, the Acer Group Defendants and their including Acer America, are essentially the same company, and the Acer Group Defendants have the right and ability to control their associates' and subsidiaries' infringing acts (including those of Acer America) and receive a direct financial benefit from that infringement.

106. For example, Defendants infringe claim 1 of the '474 patent via the Accused LCD Products such as K&D Technology LCD Model No. KD101N37-40NA-A10 incorporated into the Acer Iconia One 10. That Accused LCD Product includes an "active matrix type liquid crystal display device comprising" each of the limitations of claim 1. The technology discussion above and the example Accused LCD Product provide context for Plaintiff's allegations that each of those limitations are met. For example, the Accused LCD Product includes two opposing transparent insulating substrates and liquid crystal interposed therebetween, wherein said liquid crystal is controlled by generating an electric field substantially parallel to the liquid crystal layer with a voltage applied between pixel electrodes and common electrodes both disposed on the first of said substrates, said display device further comprising: on said first substrate: a plurality of

scanning lines and a plurality of signal lines orthogonal to one another; a thin film transistor provided near each intersection of a scanning line and a signal line; common electrodes extending substantially parallel to said scanning lines and having a plurality of comb-tooth projections extending toward said scanning lines; pixel electrodes formed substantially parallel to the comb-tooth projections in gaps between the adjacent comb-tooth projections of said common electrodes when said substrate is viewed from the normal direction, at least a portion of each pixel electrode being opposite to a common electrode interposed by an interlayer insulating film; an interlayer insulating film disposed between said common electrodes and said pixel electrodes; and a first alignment film formed above said pixel electrodes interposed by a protective insulating film; on said second substrate: a black matrix provided with openings in areas opposite to each of said pixel electrodes; and a second alignment film; and said active matrix type liquid crystal display device further comprising: accumulated capacitance increasing means for obtaining an accumulated capacitance between said pixel electrode and said common electrodes larger than that generated when said interlayer insulating film is of even thickness and flat structure.

107. At a minimum, Defendants have known of the '474 patent at least as early as the filing date of the complaint. In addition, K&D has known about the '474 patent since at least the receipt of a March 26, 2020 letter addressed to its General Counsel of Shenzhen K&D Technology Co., Ltd. that identified each Asserted Patent, except for the '070 patent, and how each patent was infringed by three LCDs from Acer Tablets. In addition, Acer America has known about the '474 patent since at least its August 19, 2020 receipt of a letter addressed to its General Counsel identifying all eight Asserted Patents and how they were infringed by Acer Iconia tablets. In addition, Acer Inc. has known about the '474 patent since at least its August 24, 2020 receipt of a letter addressed to its General Counsel identifying all eight Asserted Patents and how they were

infringed by Acer Iconia tablets. In addition, emails were sent to Peggy.Yo@acer.com and Kate.Ci.Shang@acer.com on September 8, 2020 with access to information containing evidence of use for all eight Asserted Patents.

108. Upon information and belief, since at least the above-mentioned date when Defendants were on notice of their infringement, Defendants have actively induced, under U.S.C. § 271(b), distributors, customers, subsidiaries, importers, and/or consumers that import, purchase, or sell the Accused LCD Products that include or are made using all of the limitations of one or more claims of the '474 patent to directly infringe one or more claims of the '474 patent by using, offering for sale, selling, and/or importing the Accused LCD Products. Since at least the notice provided on the above-mentioned date, Defendants do so with knowledge, or with willful blindness of the fact, that the induced acts constitute infringement of the '474 patent. Upon information and belief, Defendants intend to cause, and have taken affirmative steps to induce infringement by distributors, importers, customers, subsidiaries, and/or consumers by, inter alia, creating advertisements that promote the infringing use of the Accused LCD Products, creating established distribution channels for the Accused LCD Products into and within the United States, manufacturing the Accused LCD Products in conformity with U.S. laws and regulations, distributing or making available instructions or manuals for these products to purchasers and prospective buyers, and/or providing technical support, replacement parts, or services for these products to these purchasers in the United States.

109. Upon information and belief, despite having knowledge of the '474 patent and knowledge that it is directly and/or indirectly infringing one or more claims of the '474 patent, Defendants have nevertheless continued their infringing conduct and disregarded an objectively high likelihood of infringement. Defendants' infringing activities relative to the '474 patent have

been, and continue to be, willful, wanton, malicious, in bad-faith, deliberate, consciously wrongful, flagrant, characteristic of a pirate, and an egregious case of misconduct beyond typical infringement such that Plaintiff is entitled under 35 U.S.C. § 284 to enhanced damages up to three times the amount found or assessed.

110. Plaintiff has been damaged as a result of Defendants' infringing conduct described in this Count. Defendants are, thus, liable to Plaintiff in an amount that adequately compensates Plaintiff for Defendants' infringements, which, by law, cannot be less than a reasonable royalty, together with interest and costs as fixed by this Court under 35 U.S.C. § 284.

COUNT IV

(INFRINGEMENT OF U.S. PATENT NO. 7,009,673)

111. Plaintiff incorporates paragraphs 1 through 110 herein by reference.

112. Plaintiff is the assignee of the '673 patent, entitled "Active matrix liquid crystal display having a thin film transistor over which alignment of liquid crystal molecules does not change," with ownership of all substantial rights in the '673 patent, including the right to exclude others and to enforce, sue, and recover damages for past and future infringements.

113. The '673 patent is valid, enforceable, and was duly issued in full compliance with Title 35 of the United States Code. The '673 patent issued from U.S. Patent Application No. 10/656,138.

114. Defendants have and continue to directly and/or indirectly infringe (by inducing infringement) one or more claims of the '673 patent in this judicial district and elsewhere in Texas and the United States.

115. Upon information and belief, Defendant K&D conducts research and development, manufactures, and sells TFT-LCD products, including panels and related components. These products are incorporated into electronic devices such as tablets, including tablets manufactured

by and sold in the U.S. Defendant K&D further manufactures infringing TFT-LCD panels and related components on behalf of and for the benefit of the Acer Group Defendants. These panels and related components are incorporated into electronic devices manufactured by the Acer Group Defendants, which are marketed and sold under at least the Acer brand.

116. Upon information and belief, the Acer Group Defendants conduct research and development, manufacture, and sell electronic devices, including tablets marketed and sold under the Acer brand in the United States. These electronic devices of the Acer Group Defendants incorporate infringing TFT-LCD panels and related components (including those manufactured by Defendant K&D), device housings, backlight modules, display controllers, and processes related to the same.

117. Defendants directly infringe the '673 patent via 35 U.S.C. § 271(a) by making, offering for sale, selling, and/or importing Accused LCD Products, their components, and/or products containing same that incorporate the fundamental technologies covered by the '673 patent to, for example, alter egos, agents, intermediaries, distributors, importers, customers, subsidiaries, and/or consumers. Furthermore, upon information and belief, Defendants sell and make Accused LCD Products outside of the United States, deliver those products to their alter egos, agents, intermediaries, distributors, importers, customers, subsidiaries, and/or consumers in the United States, or in the case that Defendants deliver the Accused LCD Products outside of the United States, Defendants do so intending and/or knowing that those panels are destined for the United States and/or designing those products for sale in the United States, thereby directly infringing the '673 patent. *See, e.g., Lake Cherokee Hard Drive Techs., L.L.C. v. Marvell Semiconductor, Inc.*, 964 F. Supp.2d 653, 658 (E.D. Tex. 2013).

118. Defendant K&D directly infringes the '673 patent through its direct involvement in the activities of Acer conducted on behalf of and for the benefit of Defendant K&D. Such direct infringement includes selling and offering for sale the Accused LCD Products directly to Acer. Upon information and belief, Defendant K&D conducts activities that constitute direct infringement of the '673 patent under 35 U.S.C. § 271(a) by making, offering for sale, selling, and/or importing those Accused LCD Products.

119. The Acer Group Defendants directly infringe the '673 patent through their direct involvement in the activities of their U.S.-based subsidiaries, including, but not limited to, Acer America, conducted on behalf of and for the benefit of the Acer Group Defendants. Such direct infringement includes selling and offering for sale the Accused LCD Products directly to Acer America and importing the Accused LCD Products into the United States for the Acer Group Defendants. Upon information and belief, the Acer Group Defendants conduct activities that constitute direct infringement of the '673 patent under 35 U.S.C. § 271(a) by making, offering for sale, selling, and/or importing those Accused LCD Products. The Acer Group Defendants are vicariously liable for the infringing conduct of Acer America (under both the alter ego and agency theories). As an example and upon information and belief, the Acer Group Defendants and their including Acer America, are essentially the same company, and the Acer Group Defendants have the right and ability to control their associates' and subsidiaries' infringing acts (including those of Acer America) and receive a direct financial benefit from that infringement.

120. For example, Defendants infringe claim 1 of the '673 patent via the Accused LCD Products such as K&D Technology LCD Model No. KD101N37-40NA-A10 incorporated into the Acer Iconia One 10. That Accused LCD Product include an "active matrix liquid crystal display, comprising" each of the limitations of claim 1. The technology discussion above and the example

Accused LCD Product provide context for Plaintiff's allegations that each of those limitations are met. For example, the Accused LCD Product includes a pair of substrates with a liquid crystal layer between said substrates; a pixel electrode and a common electrode having a common longitudinal axis and that are arranged and adapted to generate an electric field parallel to said substrates in said liquid crystal layer, said liquid crystal layer having a non-zero initial alignment angle relative to the common longitudinal axis; and a thin film transistor having a source electrode and a drain electrode adjacent to a first part of said liquid crystal layer, said source and drain electrodes being arranged and adapted so that an electric field generated between said source and drain electrodes is one of substantially parallel to and perpendicular to the non-zero initial alignment angle, whereby an alignment of the first part of said liquid crystal layer does not change when an electric field is generated between said source and drain electrodes.

121. At a minimum, Defendants have known of the '673 patent at least as early as the filing date of the complaint. In addition, K&D has known about the '673 patent since at least the receipt of a March 26, 2020 letter addressed to its General Counsel of Shenzhen K&D Technology Co., Ltd. that identified each Asserted Patent, except for the '070 patent, and how each patent was infringed by three LCDs from Acer Tablets. In addition, Acer America has known about the '673 patent since at least its August 19, 2020 receipt of a letter addressed to its General Counsel identifying all eight Asserted Patents and how they were infringed by Acer Iconia tablets. In addition, Acer Inc. has known about the '673 patent since at least its August 24, 2020 receipt of a letter addressed to its General Counsel identifying all eight Asserted Patents and how they were infringed by Acer Iconia tablets. In addition, emails were sent to Peggy.Yo@acer.com and Kate.Ci.Shang@acer.com on September 8, 2020 with access to information containing evidence of use for all eight Asserted Patents.

122. Upon information and belief, since at least the above-mentioned date when Defendants were on notice of their infringement, Defendants have actively induced, under U.S.C. § 271(b), distributors, customers, subsidiaries, importers, and/or consumers that import, purchase, or sell the Accused LCD Products that include or are made using all of the limitations of one or more claims of the '673 patent to directly infringe one or more claims of the '673 patent by using, offering for sale, selling, and/or importing the Accused LCD Products. Since at least the notice provided on the above-mentioned date, Defendants do so with knowledge, or with willful blindness of the fact, that the induced acts constitute infringement of the '673 patent. Upon information and belief, Defendants intend to cause, and have taken affirmative steps to induce infringement by distributors, importers, customers, subsidiaries, and/or consumers by, inter alia, creating advertisements that promote the infringing use of the Accused LCD Products, creating established distribution channels for the Accused LCD Products into and within the United States, manufacturing the Accused LCD Products in conformity with U.S. laws and regulations, distributing or making available instructions or manuals for these products to purchasers and prospective buyers, and/or providing technical support, replacement parts, or services for these products to these purchasers in the United States.

123. Upon information and belief, despite having knowledge of the '673 patent and knowledge that it is directly and/or indirectly infringing one or more claims of the '673 patent, Defendants have nevertheless continued their infringing conduct and disregarded an objectively high likelihood of infringement. Defendants' infringing activities relative to the '673 patent have been, and continue to be, willful, wanton, malicious, in bad-faith, deliberate, consciously wrongful, flagrant, characteristic of a pirate, and an egregious case of misconduct beyond typical

infringement such that Plaintiff is entitled under 35 U.S.C. § 284 to enhanced damages up to three times the amount found or assessed.

124. Plaintiff has been damaged as a result of Defendants' infringing conduct described in this Count. Defendants are, thus, liable to Plaintiff in an amount that adequately compensates Plaintiff for Defendants' infringements, which, by law, cannot be less than a reasonable royalty, together with interest and costs as fixed by this Court under 35 U.S.C. § 284.

COUNT V

(INFRINGEMENT OF U.S. PATENT NO. 6,078,375)

125. Plaintiff incorporates paragraphs 1 through 124 herein by reference.

126. Plaintiff is the assignee of the '375 patent, entitled "Liquid crystal display device with wide viewing angle," with ownership of all substantial rights in the '375 patent, including the right to exclude others and to enforce, sue, and recover damages for past and future infringements.

127. The '375 patent is valid, enforceable, and was duly issued in full compliance with Title 35 of the United States Code. The '375 patent issued from U.S. Patent Application No. 09/154,039.

128. Defendants have and continue to directly and/or indirectly infringe (by inducing infringement) one or more claims of the '375 patent in this judicial district and elsewhere in Texas and the United States.

129. Upon information and belief, Defendant K&D conducts research and development, manufactures, and sells TFT-LCD products, including panels and related components. These products are incorporated into electronic devices such as tablets, including tablets manufactured by and sold in the U.S. Defendant K&D further manufactures infringing TFT-LCD panels and related components on behalf of and for the benefit of the Acer Group Defendants. These panels

and related components are incorporated into electronic devices manufactured by the Acer Group Defendants, which are marketed and sold under at least the Acer brand.

130. Upon information and belief, the Acer Group Defendants conduct research and development, manufacture, and sell electronic devices, including tablets marketed and sold under the Acer brand in the United States. These electronic devices of the Acer Group Defendants incorporate infringing TFT-LCD panels and related components (including those manufactured by Defendant K&D), device housings, backlight modules, display controllers, and processes related to the same.

131. Defendants directly infringe the '375 patent via 35 U.S.C. § 271(a) by making, offering for sale, selling, and/or importing Accused LCD Products, their components, and/or products containing same that incorporate the fundamental technologies covered by the '375 patent to, for example, alter egos, agents, intermediaries, distributors, importers, customers, subsidiaries, and/or consumers. Furthermore, upon information and belief, Defendants sell and make Accused LCD Products outside of the United States, deliver those products to their alter egos, agents, intermediaries, distributors, importers, customers, subsidiaries, and/or consumers in the United States, or in the case that Defendants deliver the Accused LCD Products outside of the United States, Defendants do so intending and/or knowing that those panels are destined for the United States and/or designing those products for sale in the United States, thereby directly infringing the '375 patent. *See, e.g., Lake Cherokee Hard Drive Techs., L.L.C. v. Marvell Semiconductor, Inc.*, 964 F. Supp.2d 653, 658 (E.D. Tex. 2013).

132. Defendant K&D directly infringes the '375 patent through its direct involvement in the activities of Acer conducted on behalf of and for the benefit of Defendant K&D. Such direct infringement includes selling and offering for sale the Accused LCD Products directly to Acer.

Upon information and belief, Defendant K&D conducts activities that constitute direct infringement of the '375 patent under 35 U.S.C. § 271(a) by making, offering for sale, selling, and/or importing those Accused LCD Products.

133. The Acer Group Defendants directly infringe the '375 patent through their direct involvement in the activities of their U.S.-based subsidiaries, including, but not limited to, Acer America, conducted on behalf of and for the benefit of the Acer Group Defendants. Such direct infringement includes selling and offering for sale the Accused LCD Products directly to Acer America and importing the Accused LCD Products into the United States for the Acer Group Defendants. Upon information and belief, the Acer Group Defendants conduct activities that constitute direct infringement of the '375 patent under 35 U.S.C. § 271(a) by making, offering for sale, selling, and/or importing those Accused LCD Products. The Acer Group Defendants are vicariously liable for the infringing conduct of Acer America (under both the alter ego and agency theories). As an example and upon information and belief, the Acer Group Defendants and their including Acer America, are essentially the same company, and the Acer Group Defendants have the right and ability to control their associates' and subsidiaries' infringing acts (including those of Acer America) and receive a direct financial benefit from that infringement.

134. For example, Defendants infringe claim 1 of the '375 patent via the Accused LCD Products such as K&D Technology LCD Model No. KD101N37-40NA-A10 incorporated into the Acer Iconia One 10. The Accused LCD Product includes a "liquid crystal display device comprising" each of the limitations of claim 1. The technology discussion above and the example Accused LCD Product provide context for Plaintiff's allegations that each of those limitations are met. For example, the Accused LCD Product includes a first substrate having a first principal surface; a first alignment film which is formed on said first principal surface and is subjected to a

first aligning treatment; a second substrate having a second principal surface; a second alignment film which is formed on said second principal surface, said second alignment film oppositely disposed to said first alignment film with a predetermined space left between said first alignment film and said second alignment film, and said second alignment film subjected to a second aligning treatment in the same directional orientation as the first aligning treatment; a liquid crystal layer formed by a plurality of liquid crystal molecules which are interposed and sealed between said first and said second alignment films, a part of said molecules adjacent to said first alignment film having a first pretilt angle falling within a first predetermined range which is not smaller than two degrees from said first alignment film due to the influence of said first aligning treatment, the other part of said molecules adjacent to said second alignment film having a second pretilt angle falling within a second predetermined range which is not smaller than two degrees from said second alignment film due to influence of said second aligning treatment; and field generating means for generating an electric field which is substantially parallel to said first and said second principal surfaces in said predetermined space to make said molecules rotate in accordance with said electric field.

135. At a minimum, Defendants have known of the '375 patent at least as early as the filing date of the complaint. In addition, K&D has known about the '375 patent since at least the receipt of a March 26, 2020 letter addressed to its General Counsel of Shenzhen K&D Technology Co., Ltd. that identified each Asserted Patent, except for the '070 patent, and how each patent was infringed by three LCDs from Acer Tablets. In addition, Acer America has known about the '375 patent since at least its August 19, 2020 receipt of a letter addressed to its General Counsel identifying all eight Asserted Patents and how they were infringed by Acer Iconia tablets. In addition, Acer Inc. has known about the '375 patent since at least its August 24, 2020 receipt of a

letter addressed to its General Counsel identifying all eight Asserted Patents and how they were infringed by Acer Iconia tablets. In addition, emails were sent to Peggy.Yo@acer.com and Kate.Ci.Shang@acer.com on September 8, 2020 with access to information containing evidence of use for all eight Asserted Patents.

136. Upon information and belief, since at least the above-mentioned date when Defendants were on notice of their infringement, Defendants have actively induced, under U.S.C. § 271(b), distributors, customers, subsidiaries, importers, and/or consumers that import, purchase, or sell the Accused LCD Products that include or are made using all of the limitations of one or more claims of the '375 patent to directly infringe one or more claims of the '375 patent by using, offering for sale, selling, and/or importing the Accused LCD Products. Since at least the notice provided on the above-mentioned date, Defendants do so with knowledge, or with willful blindness of the fact, that the induced acts constitute infringement of the '375 patent. Upon information and belief, Defendants intend to cause, and have taken affirmative steps to induce infringement by distributors, importers (including inducement to import in violation of § 271(g)), customers, subsidiaries, and/or consumers by, inter alia, creating advertisements that promote the infringing use of the Accused LCD Products, creating established distribution channels for the Accused LCD Products into and within the United States, manufacturing the Accused LCD Products in conformity with U.S. laws and regulations, distributing or making available instructions or manuals for these products to purchasers and prospective buyers, and/or providing technical support, replacement parts, or services for these products to these purchasers in the United States.

137. Upon information and belief, despite having knowledge of the '375 patent and knowledge that it is directly and/or indirectly infringing one or more claims of the '375 patent, Defendants have nevertheless continued their infringing conduct and disregarded an objectively

high likelihood of infringement. Defendants' infringing activities relative to the '375 patent have been, and continue to be, willful, wanton, malicious, in bad-faith, deliberate, consciously wrongful, flagrant, characteristic of a pirate, and an egregious case of misconduct beyond typical infringement such that Plaintiff is entitled under 35 U.S.C. § 284 to enhanced damages up to three times the amount found or assessed.

138. Plaintiff has been damaged as a result of Defendants' infringing conduct described in this Count. Defendants are, thus, liable to Plaintiff in an amount that adequately compensates Plaintiff for Defendants' infringements, which, by law, cannot be less than a reasonable royalty, together with interest and costs as fixed by this Court under 35 U.S.C. § 284.

COUNT VI

(INFRINGEMENT OF U.S. PATENT NO. 6,549,259)

139. Plaintiff incorporates paragraphs 1 through 138 herein by reference.

140. Plaintiff is the assignee of the '259 patent, entitled "Liquid crystal display panel and fabrication method of the same," with ownership of all substantial rights in the '259 patent, including the right to exclude others and to enforce, sue, and recover damages for past and future infringements.

141. The '259 patent is valid, enforceable, and was duly issued in full compliance with Title 35 of the United States Code. The '259 patent issued from U.S. Patent Application No. 09/780,382.

142. Defendants have and continue to directly and/or indirectly infringe (by inducing infringement) one or more claims of the '259 patent in this judicial district and elsewhere in Texas and the United States.

143. Upon information and belief, Defendant K&D conducts research and development, manufactures, and sells TFT-LCD products, including panels and related components. These

products are incorporated into electronic devices such as tablets, including tablets manufactured by and sold in the U.S. Defendant K&D further manufactures infringing TFT-LCD panels and related components on behalf of and for the benefit of the Acer Group Defendants. These panels and related components are incorporated into electronic devices manufactured by the Acer Group Defendants, which are marketed and sold under at least the Acer brand.

144. Upon information and belief, the Acer Group Defendants conduct research and development, manufacture, and sell electronic devices, including tablets marketed and sold under the Acer brand in the United States. These electronic devices of the Acer Group Defendants incorporate infringing TFT-LCD panels and related components (including those manufactured by Defendant K&D), device housings, backlight modules, display controllers, and processes related to the same.

145. Defendants directly infringe the '259 patent via 35 U.S.C. § 271(a) by making, offering for sale, selling, and/or importing Accused LCD Products, their components, and/or products containing same that incorporate the fundamental technologies covered by the '259 patent to, for example, alter egos, agents, intermediaries, distributors, importers, customers, subsidiaries, and/or consumers. Furthermore, upon information and belief, Defendants sell and make Accused LCD Products outside of the United States, deliver those products to their alter egos, agents, intermediaries, distributors, importers, customers, subsidiaries, and/or consumers in the United States, or in the case that Defendants deliver the Accused LCD Products outside of the United States, Defendants do so intending and/or knowing that those panels are destined for the United States and/or designing those products for sale in the United States, thereby directly infringing the '259 patent. *See, e.g., Lake Cherokee Hard Drive Techs., L.L.C. v. Marvell Semiconductor, Inc.*, 964 F. Supp.2d 653, 658 (E.D. Tex. 2013).

146. Defendant K&D directly infringes the '259 patent through its direct involvement in the activities of Acer conducted on behalf of and for the benefit of Defendant K&D. Such direct infringement includes selling and offering for sale the Accused LCD Products directly to Acer. Upon information and belief, Defendant K&D conducts activities that constitute direct infringement of the '259 patent under 35 U.S.C. § 271(a) by making, offering for sale, selling, and/or importing those Accused LCD Products.

147. The Acer Group Defendants directly infringe the '259 patent through their direct involvement in the activities of their U.S.-based subsidiaries, including, but not limited to, Acer America, conducted on behalf of and for the benefit of the Acer Group Defendants. Such direct infringement includes selling and offering for sale the Accused LCD Products directly to Acer America and importing the Accused LCD Products into the United States for the Acer Group Defendants. Upon information and belief, the Acer Group Defendants conduct activities that constitute direct infringement of the '259 patent under 35 U.S.C. § 271(a) by making, offering for sale, selling, and/or importing those Accused LCD Products. The Acer Group Defendants are vicariously liable for the infringing conduct of Acer America (under both the alter ego and agency theories). As an example and upon information and belief, the Acer Group Defendants and their including Acer America, are essentially the same company, and the Acer Group Defendants have the right and ability to control their associates' and subsidiaries' infringing acts (including those of Acer America) and receive a direct financial benefit from that infringement.

148. For example, Defendants infringe claim 1 of the '259 patent via the Accused LCD Products such as K&D Technology LCD Model No. KD101N37-40NA-A10 incorporated into the Acer Iconia One 10. That Accused LCD Product includes a "liquid crystal display panel comprising" each of the limitations of claim 1. The technology discussion above and the example

Accused LCD Product provide context for Plaintiff's allegations that each of those limitations are met. For example, the Accused LCD Product includes an array substrate having a switching element array; an opposing substrate opposing to said array substrate; a liquid crystal layer disposed between said array substrate and said opposing substrate; a seal member sealing said liquid crystal layer within said display panel; a spacer disposed within said seal member so as to make a gap between said array substrate and said opposing substrate constant; and a leveling layer formed on said switching element array, said leveling layer being provided with one of an opening area and a thin region at a seal area of said seal member, said thin region being thinner than thickness of said leveling layer on each switching element of said switching element array.

149. At a minimum, Defendants have known of the '259 patent at least as early as the filing date of the complaint. In addition, K&D has known about the '259 patent since at least the receipt of a March 26, 2020 letter addressed to its General Counsel of Shenzhen K&D Technology Co., Ltd. that identified each Asserted Patent, except for the '070 patent, and how each patent was infringed by three LCDs from Acer Tablets. In addition, Acer America has known about the '259 patent since at least its August 19, 2020 receipt of a letter addressed to its General Counsel identifying all eight Asserted Patents and how they were infringed by Acer Iconia tablets. In addition, Acer Inc. has known about the '259 patent since at least its August 24, 2020 receipt of a letter addressed to its General Counsel identifying all eight Asserted Patents and how they were infringed by Acer Iconia tablets. In addition, emails were sent to Peggy.Yo@acer.com and Kate.Ci.Shang@acer.com on September 8, 2020 with access to information containing evidence of use for all eight Asserted Patents.

150. Upon information and belief, since at least the above-mentioned date when Defendants were on notice of their infringement, Defendants have actively induced, under U.S.C.

§ 271(b), distributors, customers, subsidiaries, importers, and/or consumers that import, purchase, or sell the Accused LCD Products that include or are made using all of the limitations of one or more claims of the '259 patent to directly infringe one or more claims of the '259 patent by using, offering for sale, selling, and/or importing the Accused LCD Products. Since at least the notice provided on the above-mentioned date, Defendants do so with knowledge, or with willful blindness of the fact, that the induced acts constitute infringement of the '259 patent. Upon information and belief, Defendants intend to cause, and have taken affirmative steps to induce infringement by distributors, importers (including inducement to import in violation of § 271(g)), customers, subsidiaries, and/or consumers by, inter alia, creating advertisements that promote the infringing use of the Accused LCD Products, creating established distribution channels for the Accused LCD Products into and within the United States, manufacturing the Accused LCD Products in conformity with U.S. laws and regulations, distributing or making available instructions or manuals for these products to purchasers and prospective buyers, and/or providing technical support, replacement parts, or services for these products to these purchasers in the United States.

151. Upon information and belief, despite having knowledge of the '259 patent and knowledge that it is directly and/or indirectly infringing one or more claims of the '259 patent, Defendants have nevertheless continued their infringing conduct and disregarded an objectively high likelihood of infringement. Defendants' infringing activities relative to the '259 patent have been, and continue to be, willful, wanton, malicious, in bad-faith, deliberate, consciously wrongful, flagrant, characteristic of a pirate, and an egregious case of misconduct beyond typical infringement such that Plaintiff is entitled under 35 U.S.C. § 284 to enhanced damages up to three times the amount found or assessed.

152. Plaintiff has been damaged as a result of Defendants' infringing conduct

described in this Count. Defendants are, thus, liable to Plaintiff in an amount that adequately compensates Plaintiff for Defendants' infringements, which, by law, cannot be less than a reasonable royalty, together with interest and costs as fixed by this Court under 35 U.S.C. § 284.

COUNT VII

(INFRINGEMENT OF U.S. PATENT NO. 6,812,528)

153. Plaintiff incorporates paragraphs 1 through 152 herein by reference.

154. Plaintiff is the assignee of the '528 patent, entitled "Surge protection circuit for semiconductor devices," with ownership of all substantial rights in the '528 patent, including the right to exclude others and to enforce, sue, and recover damages for past and future infringements.

155. The '528 patent is valid, enforceable, and was duly issued in full compliance with Title 35 of the United States Code. The '528 patent issued from U.S. Patent Application No. 09/874,296.

156. Defendants have and continue to directly and/or indirectly infringe (by inducing infringement) one or more claims of the '528 patent in this judicial district and elsewhere in Texas and the United States.

157. Upon information and belief, Defendant K&D conducts research and development, manufactures, and sells TFT-LCD products, including panels and related components. These products are incorporated into electronic devices such as tablets, including tablets manufactured by and sold in the U.S. Defendant K&D further manufactures infringing TFT-LCD panels and related components on behalf of and for the benefit of the Acer Group Defendants. These panels and related components are incorporated into electronic devices manufactured by the Acer Group Defendants, which are marketed and sold under at least the Acer brand.

158. Upon information and belief, the Acer Group Defendants conduct research and development, manufacture, and sell electronic devices, including tablets marketed and sold under

the Acer brand in the United States. These electronic devices of the Acer Group Defendants incorporate infringing TFT-LCD panels and related components (including those manufactured by Defendant K&D), device housings, backlight modules, display controllers, and processes related to the same.

159. Defendants directly infringe the '528 patent via 35 U.S.C. § 271(a) by making, offering for sale, selling, and/or importing Accused LCD Products, their components, and/or products containing same that incorporate the fundamental technologies covered by the '528 patent to, for example, alter egos, agents, intermediaries, distributors, importers, customers, subsidiaries, and/or consumers. Furthermore, upon information and belief, Defendants sell and make Accused LCD Products outside of the United States, deliver those products to their alter egos, agents, intermediaries, distributors, importers, customers, subsidiaries, and/or consumers in the United States, or in the case that Defendants deliver the Accused LCD Products outside of the United States, Defendants do so intending and/or knowing that those panels are destined for the United States and/or designing those products for sale in the United States, thereby directly infringing the '528 patent. *See, e.g., Lake Cherokee Hard Drive Techs., L.L.C. v. Marvell Semiconductor, Inc.*, 964 F. Supp.2d 653, 658 (E.D. Tex. 2013).

160. Defendant K&D directly infringes the '528 patent through its direct involvement in the activities of Acer conducted on behalf of and for the benefit of Defendant K&D. Such direct infringement includes selling and offering for sale the Accused LCD Products directly to Acer. Upon information and belief, Defendant K&D conducts activities that constitute direct infringement of the '528 patent under 35 U.S.C. § 271(a) by making, offering for sale, selling, and/or importing those Accused LCD Products.

161. The Acer Group Defendants directly infringe the '528 patent through their direct involvement in the activities of their U.S.-based subsidiaries, including, but not limited to, Acer America, conducted on behalf of and for the benefit of the Acer Group Defendants. Such direct infringement includes selling and offering for sale the Accused LCD Products directly to Acer America and importing the Accused LCD Products into the United States for the Acer Group Defendants. Upon information and belief, the Acer Group Defendants conduct activities that constitute direct infringement of the '528 patent under 35 U.S.C. § 271(a) by making, offering for sale, selling, and/or importing those Accused LCD Products. The Acer Group Defendants are vicariously liable for the infringing conduct of Acer America (under both the alter ego and agency theories). As an example and upon information and belief, the Acer Group Defendants and their including Acer America, are essentially the same company, and the Acer Group Defendants have the right and ability to control their associates' and subsidiaries' infringing acts (including those of Acer America) and receive a direct financial benefit from that infringement.

162. For example, Defendants infringe claim 23 of the '528 patent via the Accused LCD Products such as K&D Technology LCD Model No. KD101N37-40NA-A10 incorporated into the Acer Iconia One 10. Those Accused LCD Products include a “surge protection circuit for a semiconductor display panel, comprising” each of the limitations of claim 23. The technology discussion above and the example Accused LCD Products provide context for Plaintiff's allegations that each of those limitations are met. For example, the Accused LCD Products include a plurality of vertical signal lines; a plurality of horizontal signal lines intersecting said vertical signal lines; and a plurality of floating-gate field effect transistors, each having a channel capacitance and including a floating gate electrode, a source electrode and a drain electrode, said source and drain electrodes of each of said transistors being respectively connected to said vertical

signal lines, each of said transistors being responsive to the respective vertical signal line being subjected to a surge potential for developing a voltage on said channel capacitance sufficient to turn on said floating-gate field effect transistor and establish a low-impedance path to ground.

163. At a minimum, Defendants have known of the '528 patent at least as early as the filing date of the complaint. In addition, K&D has known about the '528 patent since at least the receipt of a March 26, 2020 letter addressed to its General Counsel of Shenzhen K&D Technology Co., Ltd. that identified each Asserted Patent, except for the '070 patent, and how each patent was infringed by three LCDs from Acer Tablets. In addition, Acer America has known about the '528 patent since at least its August 19, 2020 receipt of a letter addressed to its General Counsel identifying all eight Asserted Patents and how they were infringed by Acer Iconia tablets. In addition, Acer Inc. has known about the '528 patent since at least its August 24, 2020 receipt of a letter addressed to its General Counsel identifying all eight Asserted Patents and how they were infringed by Acer Iconia tablets. In addition, emails were sent to Peggy.Yo@acer.com and Kate.Ci.Shang@acer.com on September 8, 2020 with access to information containing evidence of use for all eight Asserted Patents.

164. Upon information and belief, since at least the above-mentioned date when Defendants were on notice of their infringement, Defendants have actively induced, under U.S.C. § 271(b), distributors, customers, subsidiaries, importers, and/or consumers that import, purchase, or sell the Accused LCD Products that include or are made using all of the limitations of one or more claims of the '528 patent to directly infringe one or more claims of the '528 patent by using, offering for sale, selling, and/or importing the Accused LCD Products. Since at least the notice provided on the above-mentioned date, Defendants do so with knowledge, or with willful blindness of the fact, that the induced acts constitute infringement of the '528 patent. Upon information and

belief, Defendants intend to cause, and have taken affirmative steps to induce infringement by distributors, importers, customers, subsidiaries, and/or consumers by, inter alia, creating advertisements that promote the infringing use of the Accused LCD Products, creating established distribution channels for the Accused LCD Products into and within the United States, manufacturing the Accused LCD Products in conformity with U.S. laws and regulations, distributing or making available instructions or manuals for these products to purchasers and prospective buyers, and/or providing technical support, replacement parts, or services for these products to these purchasers in the United States.

165. Upon information and belief, despite having knowledge of the '528 patent and knowledge that it is directly and/or indirectly infringing one or more claims of the '528 patent, Defendants have nevertheless continued their infringing conduct and disregarded an objectively high likelihood of infringement. Defendants' infringing activities relative to the '528 patent have been, and continue to be, willful, wanton, malicious, in bad-faith, deliberate, consciously wrongful, flagrant, characteristic of a pirate, and an egregious case of misconduct beyond typical infringement such that Plaintiff is entitled under 35 U.S.C. § 284 to enhanced damages up to three times the amount found or assessed.

166. Plaintiff has been damaged as a result of Defendants' infringing conduct described in this Count. Defendants are, thus, liable to Plaintiff in an amount that adequately compensates Plaintiff for Defendants' infringements, which, by law, cannot be less than a reasonable royalty, together with interest and costs as fixed by this Court under 35 U.S.C. § 284.

COUNT VIII

(INFRINGEMENT OF U.S. PATENT NO. 7,593,070)

167. Plaintiff incorporates paragraphs 1 through 166 herein by reference.

168. Plaintiff is the assignee of the '070 patent, entitled "Optical unit and LCD device using the optical unit," with ownership of all substantial rights in the '070 patent, including the right to exclude others and to enforce, sue, and recover damages for past and future infringements.

169. The '070 patent is valid, enforceable, and was duly issued in full compliance with Title 35 of the United States Code. The '070 patent issued from U.S. Patent Application No. 11/984,403.

170. Defendants have and continue to directly and/or indirectly infringe (by inducing infringement) one or more claims of the '070 patent in this judicial district and elsewhere in Texas and the United States.

171. Upon information and belief, Defendant K&D conducts research and development, manufactures, and sells TFT-LCD products, including panels and related components. These products are incorporated into electronic devices such as tablets, including tablets manufactured by and sold in the U.S. Defendant K&D further manufactures infringing TFT-LCD panels and related components on behalf of and for the benefit of the Acer Group Defendants. These panels and related components are incorporated into electronic devices manufactured by the Acer Group Defendants, which are marketed and sold under at least the Acer brand.

172. Upon information and belief, the Acer Group Defendants conduct research and development, manufacture, and sell electronic devices, including tablets marketed and sold under the Acer brand in the United States. These electronic devices of the Acer Group Defendants incorporate infringing TFT-LCD panels and related components (including those manufactured by Defendant K&D), device housings, backlight modules, display controllers, and processes related to the same.

173. Defendants directly infringe the '070 patent via 35 U.S.C. § 271(a) by making, offering for sale, selling, and/or importing Accused LCD Products, their components, and/or products containing same that incorporate the fundamental technologies covered by the '070 patent to, for example, alter egos, agents, intermediaries, distributors, importers, customers, subsidiaries, and/or consumers. Furthermore, upon information and belief, Defendants sell and make Accused LCD Products outside of the United States, deliver those products to their alter egos, agents, intermediaries, distributors, importers, customers, subsidiaries, and/or consumers in the United States, or in the case that Defendants deliver the Accused LCD Products outside of the United States, Defendants do so intending and/or knowing that those panels are destined for the United States and/or designing those products for sale in the United States, thereby directly infringing the '070 patent. *See, e.g., Lake Cherokee Hard Drive Techs., L.L.C. v. Marvell Semiconductor, Inc.*, 964 F. Supp.2d 653, 658 (E.D. Tex. 2013).

174. Defendant K&D directly infringes the '070 patent through its direct involvement in the activities of Acer conducted on behalf of and for the benefit of Defendant K&D. Such direct infringement includes selling and offering for sale the Accused LCD Products directly to Acer. Upon information and belief, Defendant K&D conducts activities that constitute direct infringement of the '070 patent under 35 U.S.C. § 271(a) by making, offering for sale, selling, and/or importing those Accused LCD Products.

175. The Acer Group Defendants directly infringe the '070 patent through their direct involvement in the activities of their U.S.-based subsidiaries, including, but not limited to, Acer America, conducted on behalf of and for the benefit of the Acer Group Defendants. Such direct infringement includes selling and offering for sale the Accused LCD Products directly to Acer America and importing the Accused LCD Products into the United States for the Acer Group

Defendants. Upon information and belief, the Acer Group Defendants conduct activities that constitute direct infringement of the '070 patent under 35 U.S.C. § 271(a) by making, offering for sale, selling, and/or importing those Accused LCD Products. The Acer Group Defendants are vicariously liable for the infringing conduct of Acer America (under both the alter ego and agency theories). As an example and upon information and belief, the Acer Group Defendants and their including Acer America, are essentially the same company, and the Acer Group Defendants have the right and ability to control their associates' and subsidiaries' infringing acts (including those of Acer America) and receive a direct financial benefit from that infringement.

176. For example, Defendants infringe claim 1 of the '070 patent via the Accused LCD Products such as K&D Technology LCD Model No. KD101N37-40NA-A10 incorporated into the Acer Iconia One 10. Those Accused LCD Products include a “optical unit, comprising” each of the limitations of claim 1. The technology discussion above and the example Accused LCD Products provide context for Plaintiff's allegations that each of those limitations are met. For example, the Accused LCD Products include a frame surrounding an opening, the frame having a first surface and a second surface, placed directly across from the first surface of the frame; a light conductive plate positioned in the opening of the frame, the light conductive plate having a first surface adjacent the first surface of the frame and a second surface adjacent the second surface of the frame; a diffusion sheet fastened to the first surface of the frame in a manner to cover at least a portion of the first surface of the frame and to cover the first surface of the light conductive plate; and a light reflective sheet fastened to the second surface of the frame in a manner to cover at least a portion of the second surface of the frame and to cover the second surface of the light conductive plate, wherein the diffusion sheet and the light reflective sheet cooperate to fasten the light conductive plate within the frame.

177. At a minimum, Defendants have known of the '070 patent at least as early as the filing date of the complaint. In addition, Acer America has known about the '070 patent since at least its August 19, 2020 receipt of a letter addressed to its General Counsel identifying all eight Asserted Patents and how they were infringed by Acer Iconia tablets. In addition, Acer Inc. has known about the '070 patent since at least its August 24, 2020 receipt of a letter addressed to its General Counsel identifying all eight Asserted Patents and how they were infringed by Acer Iconia tablets. In addition, emails were sent to Peggy.Yo@acer.com and Kate.Ci.Shang@acer.com on September 8, 2020 with access to information containing evidence of use for all eight Asserted Patents.

178. Upon information and belief, since at least the above-mentioned date when Defendants were on notice of their infringement, Defendants have actively induced, under U.S.C. § 271(b), distributors, customers, subsidiaries, importers, and/or consumers that import, purchase, or sell the Accused LCD Products that include or are made using all of the limitations of one or more claims of the '070 patent to directly infringe one or more claims of the '070 patent by using, offering for sale, selling, and/or importing the Accused LCD Products. Since at least the notice provided on the above-mentioned date, Defendants do so with knowledge, or with willful blindness of the fact, that the induced acts constitute infringement of the '070 patent. Upon information and belief, Defendants intend to cause, and have taken affirmative steps to induce infringement by distributors, importers (including inducement to import in violation of § 271(g)), customers, subsidiaries, and/or consumers by, inter alia, creating advertisements that promote the infringing use of the Accused LCD Products, creating established distribution channels for the Accused LCD Products into and within the United States, manufacturing the Accused LCD Products in conformity with U.S. laws and regulations, distributing or making available instructions or

manuals for these products to purchasers and prospective buyers, and/or providing technical support, replacement parts, or services for these products to these purchasers in the United States.

179. Upon information and belief, despite having knowledge of the '070 patent and knowledge that it is directly and/or indirectly infringing one or more claims of the '070 patent, Defendants have nevertheless continued their infringing conduct and disregarded an objectively high likelihood of infringement. Defendants' infringing activities relative to the '070 patent have been, and continue to be, willful, wanton, malicious, in bad-faith, deliberate, consciously wrongful, flagrant, characteristic of a pirate, and an egregious case of misconduct beyond typical infringement such that Plaintiff is entitled under 35 U.S.C. § 284 to enhanced damages up to three times the amount found or assessed.

180. Plaintiff has been damaged as a result of Defendants' infringing conduct described in this Count. Defendants are, thus, liable to Plaintiff in an amount that adequately compensates Plaintiff for Defendants' infringements, which, by law, cannot be less than a reasonable royalty, together with interest and costs as fixed by this Court under 35 U.S.C. § 284.

CONCLUSION

181. Plaintiff is entitled to recover from Defendant the damages sustained by Plaintiff as a result of Defendants' wrongful acts in an amount subject to proof at trial, which, by law, cannot be less than a reasonable royalty, together with interest and costs as fixed by this Court.

182. Plaintiff has incurred and will incur attorneys' fees, costs, and expenses in the prosecution of this action. The circumstances of this dispute may give rise to an exceptional case within the meaning of 35 U.S.C. § 285, and Plaintiff is entitled to recover its reasonable and necessary attorneys' fees, costs, and expenses.

JURY DEMAND

183. Plaintiff hereby requests a trial by jury pursuant to Rule 38 of the Federal Rules of Civil Procedure.

PRAYER FOR RELIEF

184. Plaintiff respectfully requests that the Court find in its favor and against Defendants, and that the Court grant Plaintiff the following relief:

1. A judgment that Defendants have infringed the Asserted Patents as alleged herein, directly and/or indirectly by way of inducing infringement of such patents;
2. A judgment for an accounting of all damages sustained by Plaintiff as a result of the acts of infringement by Defendants;
3. A preliminary and permanent injunction against Defendants, their subsidiaries, or anyone acting on their behalf from making, using, selling, offering to sell, or importing any products that infringe the Asserted Patents, and any other injunctive relief the Court deems just and equitable;
4. A judgment and order requiring Defendants to pay Plaintiff damages under 35 U.S.C. § 284, including up to treble damages as provided by 35 U.S.C. § 284, and any royalties determined to be appropriate;
5. A judgment and order requiring Defendants to pay Plaintiff pre-judgment and post-judgment interest on the damages awarded;
6. A judgment and order finding this to be an exceptional case and requiring Defendants to pay the costs of this action (including all disbursements) and attorneys' fees as provided by 35 U.S.C. § 285; and
7. Such other and further relief as the Court deems just and equitable.

Dated: December 29, 2021

Respectfully submitted,

/s/ Patrick J. Conroy

Patrick J. Conroy

Texas Bar No. 24012448

Justin Kimble

Texas Bar No. 24036909

T. William Kennedy Jr.

Texas Bar No. 24055771

Jon Rastegar

Texas Bar No. 24064043

Ryan Griffin

Texas Bar No. 24053687

Nelson Bumgardner Conroy PC

2727 North Harwood Street

Suite 250

Dallas, TX 75201

Tel: (214) 446-4954

pat@nelbum.com

justin@nelbum.com

bill@nelbum.com

jon@nelbum.com

ryan@nelbum.com

Attorneys for Plaintiff

Vista Peak Ventures, LLC