

**UNITED STATES DISTRICT COURT  
FOR THE EASTERN DISTRICT OF TEXAS  
MARSHALL DIVISION**

SPEIR TECHNOLOGIES LTD.,

Plaintiff,

v.

SAMSUNG ELECTRONICS CO., LTD. and  
SAMSUNG ELECTRONICS AMERICA, INC.,

Defendants.

Case No. 2:21-cv-00474

**JURY TRIAL DEMANDED**

**COMPLAINT FOR PATENT INFRINGEMENT  
AGAINST SAMSUNG ELECTRONICS CO., LTD AND  
SAMSUNG ELECTRONICS AMERICA, INC.**

This is an action for patent infringement arising under the Patent Laws of the United States of America, 35 U.S.C. § 1 *et seq.*, in which Plaintiff Speir Technologies Limited (“Plaintiff” or “Speir”) makes the following allegations against Defendants Samsung Electronics Co., Ltd. (“SEC”) and Samsung Electronics America, Inc. (“SEA”) (collectively, “Defendants” or “Samsung”):

**INTRODUCTION**

1. This complaint arises from Samsung’s unlawful infringement of the following United States patents owned by Plaintiff, which relate to improvements in mobile communications systems: United States Patent Nos. 8,345,780 (“the ’780 Patent”), 7,110,779 (“the ’779 Patent”), and 7,321,777 (“the ’777 Patent”) (collectively, the “Asserted Patents”).

**PARTIES**

2. Plaintiff Speir Technologies Limited is a limited liability company organized and existing under the law of Ireland, with its principal place of business at The Hyde Building, Suite

23, The Park, Carrickmines, Dublin 18, Ireland. Speir is the sole owner by assignment of all rights, title, and interest in the Asserted Patents, including the right to recover damages for past, present, and future infringement.

3. On information and belief, Defendant Samsung Electronics Co., Ltd. is a corporation organized under the laws of South Korea, with its principal place of business at 129 Samsung-ro, Maetan-dong, Yeongtong-gu, Suwon-si, Gyeonggi-do, 443-742, South Korea.

4. On information and belief, Defendant Samsung Electronics America, Inc., a wholly owned subsidiary of Samsung Electronics Co., Ltd., is a corporation organized under the laws of the State of New York, with its principal place of business at 85 Challenger Rd., Ridgefield Park, New Jersey 07660.

#### **JURISDICTION AND VENUE**

5. This action arises under the patent laws of the United States, Title 35 of the United States Code. This Court has original subject matter jurisdiction pursuant to 28 U.S.C. §§ 1331 and 1338(a).

6. This Court has personal jurisdiction over Samsung in this action because Samsung has committed acts within this District giving rise to this action and has established minimum contacts with this forum such that the exercise of jurisdiction over Samsung would not offend traditional notions of fair play and substantial justice. Samsung, directly and through subsidiaries or intermediaries, has committed and continues to commit acts of infringement in this District by, among other things, making, using, importing, offering to sell, and selling products that infringe the Asserted Patents. Samsung has not contested personal jurisdiction in this District in prior cases. *See, e.g., Clear Imaging Research, LLC v. Samsung Elecs. Co. Ltd.*, No. 2:19-cv-326, Dkt. No. 23, ¶ 7 (E.D. Tex. Jan. 22, 2020).

7. Venue is proper in this District under 28 U.S.C. §§ 1391 and 1400(b). Upon information and belief, Defendants have transacted business in this District and have committed acts of direct and indirect infringement in this District by, among other things, making, using, importing, offering to sell, and selling products that infringe the Asserted Patents. Venue is proper as to Defendant SEC because it is a foreign corporation organized under the laws of Korea, with a principal place of business in Korea, and suits against foreign entities are proper in any judicial district. *See* 28 U.S.C. § 1391(c)(3); *In re HTC Corp.*, 889 F.3d 1349 (Fed. Cir. 2018). Venue is also proper as to Defendant SEA, which is registered to do business in Texas. SEA has a regular and established place of businesses in this District, including at 6625 Excellence Way, Plano, Texas 75023. SEA currently has nearly 100 job postings in Plano, Texas, including for jobs related to the accused 5G technologies.<sup>1</sup>

### **THE ASSERTED PATENTS**

8. On January 1, 2013, the United States Patent and Trademark Office issued U.S. Patent No. 8,345,780 (“the ’780 Patent”), entitled “Wireless communication system compensating for interference and related methods,” after full and fair examination. Plaintiff is the assignee of all rights, title, and interest in and to the ’780 Patent and possesses all rights of recovery under the ’780 Patent, including the right to recover damages for past, present, and future infringement. The ’780 Patent is valid and enforceable. A true and correct copy of the ’780 Patent is attached hereto as Exhibit 1.

---

<sup>1</sup> *See, e.g.*, [https://sec.wd3.myworkdayjobs.com/en-US/Samsung\\_Careers/job/6625-Excellence-Way-Plano-TX-USA/N1-4G-5G-Call-Processing-Senior-RAN-SME--Ref-363\\_R45993](https://sec.wd3.myworkdayjobs.com/en-US/Samsung_Careers/job/6625-Excellence-Way-Plano-TX-USA/N1-4G-5G-Call-Processing-Senior-RAN-SME--Ref-363_R45993); [https://sec.wd3.myworkdayjobs.com/en-US/Samsung\\_Careers/job/6625-Excellence-Way-Plano-TX-USA/N1--4G-5G-Call-Processing-RAN-SME--REF-423\\_R46640](https://sec.wd3.myworkdayjobs.com/en-US/Samsung_Careers/job/6625-Excellence-Way-Plano-TX-USA/N1--4G-5G-Call-Processing-RAN-SME--REF-423_R46640); [https://sec.wd3.myworkdayjobs.com/en-US/Samsung\\_Careers/job/6625-Excellence-Way-Plano-TX-USA/N1--5G-Systems-Test-Engineer\\_R36848](https://sec.wd3.myworkdayjobs.com/en-US/Samsung_Careers/job/6625-Excellence-Way-Plano-TX-USA/N1--5G-Systems-Test-Engineer_R36848).

9. On September 19, 2006, the United States Patent and Trademark Office issued U.S. Patent No. 7,110,779 (“the ’779 Patent”), entitled “Wireless communication system including a wireless device locator and related methods,” after full and fair examination. Plaintiff is the assignee of all rights, title, and interest in and to the ’779 Patent and possesses all rights of recovery under the ’779 Patent, including the right to recover damages for past, present, and future infringement. The ’779 Patent is valid and enforceable. A true and correct copy of the ’779 Patent is attached hereto as Exhibit 2.

10. On January 22, 2008, the United States Patent and Trademark Office issued U.S. Patent No. 7,321,777 (“the ’777 Patent”), entitled “Wireless communications system including a wireless device locator and related methods,” after full and fair examination. Plaintiff is the assignee of all rights, title, and interest in and to the ’777 Patent and possesses all rights of recovery under the ’777 Patent, including the right to recover damages for past, present, and future infringement. The ’777 Patent is valid and enforceable. A true and correct copy of the ’777 Patent is attached hereto as Exhibit 3.

### **SAMSUNG’S INFRINGEMENT**

11. The allegations provided below are exemplary and without prejudice to Plaintiff’s infringement contentions provided pursuant to the Court’s scheduling order and local rules. Plaintiff’s claim construction contentions regarding the meaning and scope of the claim terms will be provided under the Court’s scheduling order and local rules. As detailed below, each element of at least one claim of each of the Asserted Patents is literally present in the accused products. To the extent that any element is not literally present, each such element is present under the doctrine of equivalents. Plaintiff’s analysis below should not be taken as an admission that the preamble is limiting. While publicly available information is cited below, Plaintiff may rely on other forms of

evidence to prove infringement, including evidence that is solely in the possession of Samsung and/or third parties.

12. The accused products include at least the following products, as well as products with reasonably similar functionality, and all Edge, Plus (+), and Active varieties of these products. Identification of the accused products will be provided in plaintiff's infringement contentions pursuant to the Court's scheduling order and local rules. Samsung imports into the United States, uses, makes, offers for sale, and sells in the United States the following products and infringes the asserted claims of the patents-in-suit (the "Accused Products"):

- '780 Patent Accused Products: Galaxy S10 5G, S20 5G, S20 + 5G, S20 Ultra 5G, S20 FE 5G, S21 5G, S21+ 5G, S21 Ultra 5G, Note 10 5G, Note 10+ 5G, Note 20 5G, Note 20 Ultra 5G, A51 5G, A52 5G, A42 5G, A32 5G, A71 5G, Fold 2 5G, Flip 5G, Flip 3 5G, Z Fold3 5G, Tab S7 FE 5G, Tab S7 5G, Tab S7+ 5G, and any other products with 5G functionality.
- '779 Patent and '777 Patent Accused Products: Galaxy Note20 Ultra, S21+, S21 Ultra, Z Fold2, Z Fold3 5G, SmartTag+, and any other products with UWB functionality.

## **COUNT I**

### **INFRINGEMENT OF U.S. PATENT NO. 8,345,780**

13. Plaintiff realleges and incorporates by reference the foregoing paragraphs as if fully set forth herein.

14. Samsung has been and is now directly infringing the '780 Patent, literally and/or under the doctrine of equivalents, in violation of 35 U.S.C. § 271(a), including by making, using, selling, and/or offering for sale in the United States or importing into the United States infringing products, including at least the Accused Products identified above. The Accused Products satisfy

all of the claim limitations of one or more claims of the '780 Patent, including but not limited to claim 9.

15. Claim 9 of the '780 Patent recites “[a] wireless communications device operable to communicate with an other wireless communications device via a wireless communications link having at least one settable link characteristic.” To the extent the preamble is limiting, the Accused Products each comprise a wireless communications device operable to communicate with an other wireless communications device via a wireless communications link having at least one settable link characteristic. For example, the Accused Products are configured to communicate with base stations using 5G cellular technology:

Network & Connectivity	Galaxy S21 5G and S21+ 5G	Galaxy S21 Ultra 5G
	5G	5G
	5G Non-Standalone (NSA), Standalone (SA), Sub6 / mmWave	5G Non-Standalone (NSA), Standalone (SA), Sub6 / mmWave

See <https://www.samsung.com/global/galaxy/galaxy-s21-ultra-5g/specs/>.

16. Claim 9 of the '780 Patent recites that the “wireless communications device” comprises “an orthogonal frequency-division multiplexing (OFDM) wireless transceiver.” The Accused Products each comprise an orthogonal frequency-division multiplexing (OFDM) wireless transceiver. For example, 5G uses OFDM in both the uplink and the downlink:

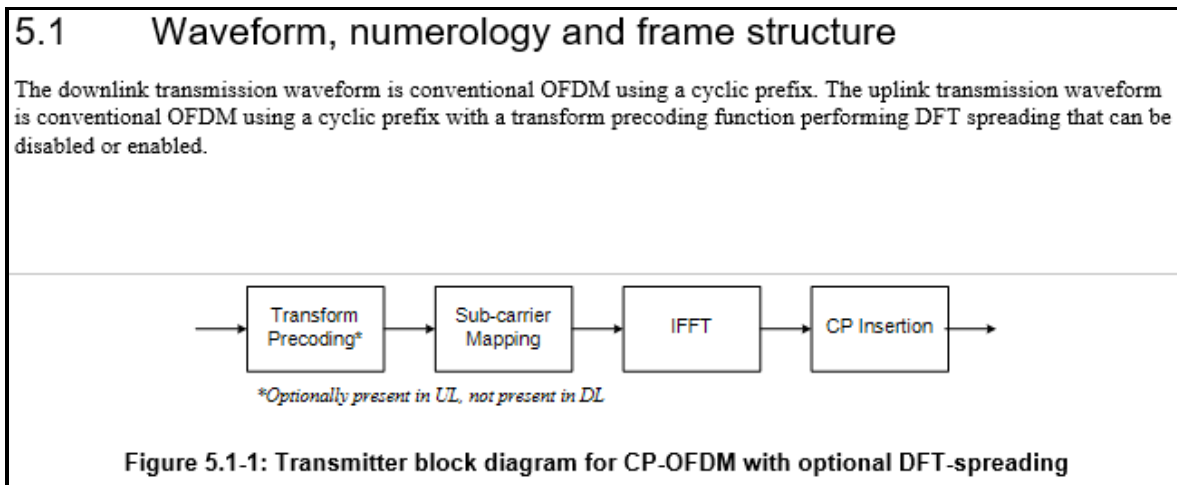

See 3GPP TS 38.300 V15.13.0.

### 5.3.1 OFDM baseband signal generation for all channels except PRACH

The time-continuous signal  $s_l^{(p,\mu)}(t)$  on antenna port  $p$  and subcarrier spacing configuration  $\mu$  for OFDM symbol  $l \in \{0, 1, \dots, N_{\text{slot}}^{\text{subframe}, \mu} N_{\text{symbol}}^{\text{slot}} - 1\}$  in a subframe for any physical channel or signal except PRACH is defined by

$$s_l^{(p,\mu)}(t) = \sum_{k=0}^{N_{\text{grid}}^{\text{max}, \mu} N_{\text{sc}}^{\text{RB}} - 1} d_{k,l}^{(p,\mu)} \cdot e^{j2\pi \left( k + k_0^{\mu} - N_{\text{grid},x}^{\text{max}, \mu} N_{\text{sc}}^{\text{RB}} / 2 \right) \Delta f \left( t - N_{\text{CP},l}^{\mu} T_c - t_{\text{start},l}^{\mu} \right)}$$

$$k_0^{\mu} = \left( N_{\text{grid},x}^{\text{start}, \mu} + N_{\text{grid},x}^{\text{size}, \mu} / 2 \right) N_{\text{sc}}^{\text{RB}} - \left( N_{\text{grid},x}^{\text{start}, \mu} + N_{\text{grid},x}^{\text{size}, \mu} / 2 \right) N_{\text{sc}}^{\text{RB}} 2^{\mu_0 - \mu}$$

where  $t_{\text{start},l}^{\mu} \leq t < t_{\text{start},l}^{\mu} + \left( N_{\text{u}}^{\mu} + N_{\text{CP},l}^{\mu} \right) T_c$  is the time within the subframe,

$$N_{\text{u}}^{\mu} = 2048 \kappa \cdot 2^{-\mu}$$

$$N_{\text{CP},l}^{\mu} = \begin{cases} 512 \kappa \cdot 2^{-\mu} & \text{extended cyclic prefix} \\ 144 \kappa \cdot 2^{-\mu} + 16 \kappa & \text{normal cyclic prefix, } l = 0 \text{ or } l = 7 \cdot 2^{\mu} \\ 144 \kappa \cdot 2^{-\mu} & \text{normal cyclic prefix, } l \neq 0 \text{ and } l \neq 7 \cdot 2^{\mu} \end{cases}$$

See 3GPP TS 38.211 V15.9.0.

17. Claim 9 of the '780 Patent recites “a controller coupled to said wireless transceiver and configured to store short term and long term historical characteristics of interference.” The Accused Products each comprise a controller coupled to said wireless transceiver and configured to store short term and long term historical characteristics of interference. For example, the controllers in the Accused Products are configured to store short term and long term historical characteristics of interference:

CSI-ReportConfig	
The IE <i>CSI-ReportConfig</i> is used to configure a periodic or semi-persistent report sent on PUCCH on the cell in which the <i>CSI-ReportConfig</i> is included, or to configure a semi-persistent or aperiodic report sent on PUSCH triggered by DCI received on the cell in which the <i>CSI-ReportConfig</i> is included (in this case, the cell on which the report is sent is determined by the received DCI). See TS 38.214 [19], clause 5.2.1.	
CSI-ReportConfig information element	
-- ASN1START	
-- TAG-CSI-REPORTCONFIG-START	
CSI-ReportConfig ::=	SEQUENCE {
reportConfigId	CSI-ReportConfigId,
carrier	ServCellIndex, OPTIONAL, -- Need S
resourcesForChannelMeasurement	CSI-ResourceConfigId,
csi-IM-ResourcesForInterference	CSI-ResourceConfigId, OPTIONAL, -- Need R
nzp-CSI-RS-ResourcesForInterference	CSI-ResourceConfigId, OPTIONAL, -- Need R
reportConfigType	CHOICE {
periodic	SEQUENCE {
reportSlotConfig	CSI-ReportPeriodicityAndOffset,
pucch-CSI-ResourceList	SEQUENCE (SIZE (1..maxNrofBWP)) OF PUCCH-CSI-Resource
},	
semiPersistentOnPUCCH	SEQUENCE {
reportSlotConfig	CSI-ReportPeriodicityAndOffset,
pucch-CSI-ResourceList	SEQUENCE (SIZE (1..maxNrofBWP)) OF PUCCH-CSI-Resource
},	
semiPersistentOnPUSCH	SEQUENCE {
reportSlotConfig	ENUMERATED {s15, s110, s120, s140, s180, s1160, s1320},
reportSlotOffsetList	SEQUENCE (SIZE (1..maxNrofUL-Allocations)) OF INTEGER(0..32),
pAlpha	P0-PUSCH-AlphaSetId
},	
aperiodic	SEQUENCE {
reportSlotOffsetList	SEQUENCE (SIZE (1..maxNrofUL-Allocations)) OF INTEGER(0..32)
},	
reportQuantity	CHOICE {
none	NULL,
cri-RI-PMI-CQI	NULL,
cri-RI-i1	NULL,
cri-RI-i1-CQI	SEQUENCE {
pdsch-BundleSizeForCSI	ENUMERATED {n2, n4} OPTIONAL -- Need S
},	
cri-RI-CQI	NULL,
cri-RSRP	NULL,
ssb-Index-RSRP	NULL,
cri-RI-LI-PMI-CQI	NULL
},	

See 3GPP TS 38.331 V15.15.0.



<b>CSI-ReportConfig field descriptions</b>
<b>carrier</b> Indicates in which serving cell the <i>CSI-ResourceConfig</i> indicated below are to be found. If the field is absent, the resources are on the same serving cell as this report configuration.
<b>codebookConfig</b> Codebook configuration for Type-1 or Type-2 including codebook subset restriction.
<b>cqi-FormatIndicator</b> Indicates whether the UE shall report a single (wideband) or multiple (subband) CQI (see TS 38.214 [19], clause 5.2.1.4).
<b>cqi-Table</b> Which CQI table to use for CQI calculation (see TS 38.214 [19], clause 5.2.2.1).
<b>csi-IM-ResourcesForInterference</b> CSI IM resources for interference measurement. <i>csi-ResourceConfigId</i> of a <i>CSI-ResourceConfig</i> included in the configuration of the serving cell indicated with the field "carrier" above. The <i>CSI-ResourceConfig</i> indicated here contains only CSI-IM resources. The <i>bwp-Id</i> in that <i>CSI-ResourceConfig</i> is the same value as the <i>bwp-Id</i> in the <i>CSI-ResourceConfig</i> indicated by <i>resourcesForChannelMeasurement</i> .
<b>csi-ReportingBand</b> Indicates a contiguous or non-contiguous subset of subbands in the bandwidth part which CSI shall be reported for. Each bit in the bit-string represents one subband. The right-most bit in the bit string represents the lowest subband in the BWP. The choice determines the number of subbands (subbands3 for 3 subbands, subbands4 for 4 subbands, and so on) (see TS 38.214 [19], clause 5.2.1.4). This field is absent if there are less than 24 PRBs (no sub band) and present otherwise (see TS 38.214 [19], clause 5.2.1.4).
<b>dummy</b> This field is not used in the specification. If received it shall be ignored by the UE.
<b>groupBasedBeamReporting</b> Turning on/off group beam based reporting (see TS 38.214 [19], clause 5.2.1.4).
<b>non-PMI-PortIndication</b> Port indication for RI/CQI calculation. For each CSI-RS resource in the linked <i>ResourceConfig</i> for channel measurement, a port indication for each rank R, indicating which R ports to use. Applicable only for non-PMI feedback (see TS 38.214 [19], clause 5.2.1.4.2). The first entry in <i>non-PMI-PortIndication</i> corresponds to the NZP-CSI-RS-Resource indicated by the first entry in <i>nzp-CSI-RS-Resources</i> in the <i>NZP-CSI-RS-ResourceSet</i> indicated in the first entry of <i>nzp-CSI-RS-ResourceSetList</i> of the <i>CSI-ResourceConfig</i> whose <i>CSI-ResourceConfigId</i> is indicated in a <i>CSI-MeasId</i> together with the above <i>CSI-ReportConfigId</i> , the second entry in <i>non-PMI-PortIndication</i> corresponds to the NZP-CSI-RS-Resource indicated by the second entry in <i>nzp-CSI-RS-Resources</i> in the <i>NZP-CSI-RS-ResourceSet</i> indicated in the first entry of <i>nzp-CSI-RS-ResourceSetList</i> of the same <i>CSI-ResourceConfig</i> , and so on until the NZP-CSI-RS-Resource indicated by the last entry in <i>nzp-CSI-RS-Resources</i> in the in the <i>NZP-CSI-RS-ResourceSet</i> indicated in the first entry of <i>nzp-CSI-RS-ResourceSetList</i> of the same <i>CSI-ResourceConfig</i> . Then the next entry corresponds to the NZP-CSI-RS-Resource indicated by the first entry in <i>nzp-CSI-RS-Resources</i> in the <i>NZP-CSI-RS-ResourceSet</i> indicated in the second entry of <i>nzp-CSI-RS-ResourceSetList</i> of the same <i>CSI-ResourceConfig</i> and so on.
<b>nrofReportedRS</b> The number (N) of measured RS resources to be reported per report setting in a non-group-based report. $N \leq N_{max}$ , where $N_{max}$ is either 2 or 4 depending on UE capability. (see TS 38.214 [19], clause 5.2.1.4) When the field is absent the UE applies the value 1.
<b>nzp-CSI-RS-ResourcesForInterference</b> NZP CSI RS resources for interference measurement. <i>csi-ResourceConfigId</i> of a <i>CSI-ResourceConfig</i> included in the configuration of the serving cell indicated with the field "carrier" above. The <i>CSI-ResourceConfig</i> indicated here contains only NZP-CSI-RS resources. The <i>bwp-Id</i> in that <i>CSI-ResourceConfig</i> is the same value as the <i>bwp-Id</i> in the <i>CSI-ResourceConfig</i> indicated by <i>resourcesForChannelMeasurement</i> .

See 3GPP TS 38.331 V15.15.0.

<b>resourcesForChannelMeasurement</b> Resources for channel measurement. <i>csi-ResourceConfigId</i> of a <i>CSI-ResourceConfig</i> included in the configuration of the serving cell indicated with the field "carrier" above. The <i>CSI-ResourceConfig</i> indicated here contains only NZP-CSI-RS resources and/or SSB resources. This <i>CSI-ReportConfig</i> is associated with the DL BWP indicated by <i>bwp-Id</i> in that <i>CSI-ResourceConfig</i> .
<b>subbandSize</b> Indicates one out of two possible BWP-dependent values for the subband size as indicated in TS 38.214 [19], table 5.2.1.4-2. If <i>csi-ReportingBand</i> is absent, the UE shall ignore this field.
<b>timeRestrictionForChannelMeasurements</b> Time domain measurement restriction for the channel (signal) measurements (see TS 38.214 [19], clause 5.2.1.1).
<b>timeRestrictionForInterferenceMeasurements</b> Time domain measurement restriction for interference measurements (see TS 38.214 [19], clause 5.2.1.1).

See 3GPP TS 38.331 V15.15.0.

Many transmission features in modern radio-access technologies are based on the availability of more or less detailed knowledge about different characteristics of the radio channel over which a signal is to be transmitted. This may range from rough knowledge of the radio-channel path loss for transmit-power adjustment to detailed knowledge about the channel amplitude and phase in the time, frequency, and/or spatial domain. Many transmission features will also benefit from knowledge about the interference level experienced at the receiver side.

Such knowledge about different channel characteristics can be acquired in different ways and by measurements on either the transmitter side or receiver side of a radio link. As an example, knowledge about downlink channel characteristics can be acquired by means of device measurements. The acquired information could then be reported to the network for the setting of different transmission parameters for subsequent downlink transmissions. Alternatively, if it can be assumed that the channel is reciprocal, that is, the channel characteristics of inter-

See Erik Dahlman et al., 5G NR: The Next Generation Wireless Access Technology, Ch. 8 Abstract (2d Ed. 2018).

### 3.7.4 CHANNEL STATE INFORMATION REFERENCE SIGNAL

- ★ The Channel State Information (CSI) Reference Signal is a multi-purpose downlink transmission. The Base Station can configure the UE to use the CSI Reference Signal for one or more of the following:
  - Channel State Information (CSI) Reporting: the UE provides CSI reports to the Base Station based upon measurements from the CSI Reference Signal. For example, the UE derives Channel Quality Indicators (CQI), Rank Indicators (RI) and Precoding Matrix Indicators (PMI) from CSI Reference Signal measurements (Channel State Information is described in section 13.6)

See Chris Johnson, 5G New Radio in Bullets, Section 3.7.4. (2019).

- ★ Figure 186 illustrates an example Multi-User MIMO scenario which involves 3 UE being allocated a common set of Resource Blocks and symbols. Each UE is configured with 2 NZP CSI Reference Signal resources for 'Interference Measurement' and 1 NZP CSI Reference Signal resource for 'Channel Measurement'. The resources are configured such that 2 UE complete interference measurements while the 3<sup>rd</sup> UE receives its NZP CSI Reference Signal for channel measurement, i.e. 2 UE measure the interference levels generated when transmissions are scheduled towards the 3<sup>rd</sup> UE. This allows each UE to generate CQI reports which reflect the multi-user MIMO radio conditions

See Chris Johnson, 5G New Radio in Bullets, Section 3.7.4. (2019).

- ★ If a UE is scheduled downlink resources using single user MIMO then interference levels are likely to be dominated by intercell interference (or thermal noise) and so UE measurements should target those sources of interference. 3GPP has specified a third category of CSI Reference Signal resources which can be used for this purpose. These resources are known as **CSI Interference Measurement (IM) Resources**. The Resource Elements configured for this purpose may be used to measure background interference levels, i.e. the serving cell does not transmit anything within these Resource Elements so the UE can measure background interference originating from neighbouring cells

See Chris Johnson, 5G New Radio in Bullets, Section 3.7.4. (2019).

#### 8.1.4: CSI-IM—Resources for Interference Measurements

A configured CSI-RS can be used to derive information about the properties of the channel over which the CSI-RS transmitted. A CSI-RS can also be used to estimate the interference level by subtracting the expected received signal from what is actually received on the CSI-RS resource.

However, the interference level can also be estimated from measurements on so-called *CSI-IM* (Interference Measurement) resources.

See Erik Dahlman et al., 5G NR: The Next Generation Wireless Access Technology, § 8.1.4 (2d Ed. 2018).

```

- CSI-ReportConfig
The IE CSI-ReportConfig is used to configure a periodic or semi-persistent report sent on PUCCH on the cell in which the CSI-ReportConfig is included, or to configure a semi-persistent or aperiodic report sent on PUSCH triggered by DCI received on the cell in which the CSI-ReportConfig is included (in this case, the cell on which the report is sent is determined by the received DCI). See TS 38.214 [19], clause 5.2.1.

CSI-ReportConfig information element

-- ASN1START
-- TAG-CSI-REPORTCONFIG-START
CSI-ReportConfig ::= SEQUENCE {
    reportConfigId          CSI-ReportConfigId,
    carrier                 ServCellIndex          OPTIONAL, -- Need S
    resourcesForChannelMeasurement CSI-ResourceConfigId,
    csi-IM-ResourcesForInterference CSI-ResourceConfigId OPTIONAL, -- Need R
    nzp-CSI-RS-ResourcesForInterference CSI-ResourceConfigId OPTIONAL, -- Need R
    reportConfigType       CHOICE {
        periodic          SEQUENCE {
            reportSlotConfig CSI-ReportPeriodicityAndOffset,
            pucch-CSI-ResourceList SEQUENCE (SIZE (1..maxNrofBWP)) OF PUCCH-CSI-Resource
        },
        ...
    }
}
    
```

See 3GPP TS 38.331 V15.15.0.

18. Claim 9 of the '780 Patent recites that the “controller” is configured to “detect received interference.” The Accused Products each comprise a controller configured to detect received interference. For example, the Accused Products are configured to receive the channel state information (“CSI”) CSI-ReportConfig parameter structure that informs the user equipment (“UE”) of the channel and interference measurements it should make:

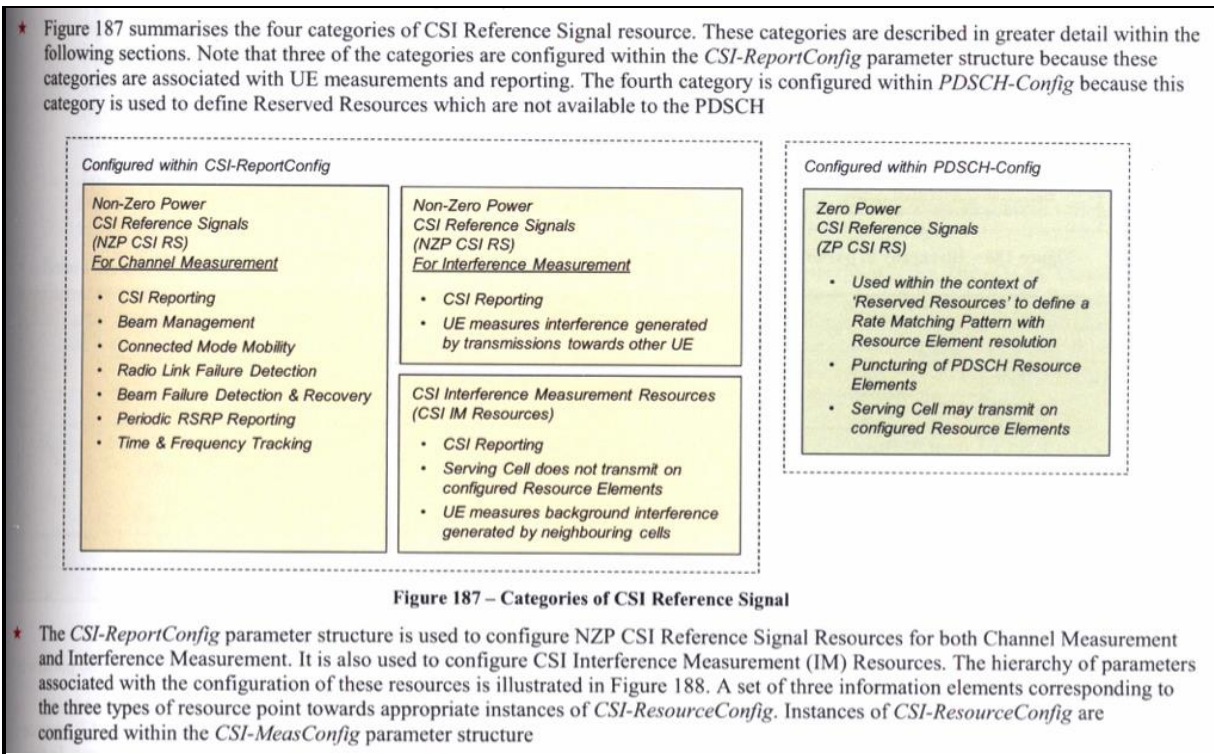

See Chris Johnson, 5G New Radio in Bullets, Section 3.7.4. (2019).

## 8.2: Downlink Measurements and Reporting

An NR device can be configured to carry out different measurements, in most cases with corresponding reporting to the network. In general, such a configuration of a measurement and corresponding reporting are done by means of a *report configuration*, in the 3GPP specifications [15] referred to as a *CSI-ReportConfig*.<sup>4</sup>

Each resource configuration describes/indicates:

- The specific quantity or set of quantities to be reported;
- The downlink resource(s) on which measurements should be carried out in order to derive the quantity or quantities to be reported;
- How the actual reporting is to be carried out, for example, when the reporting is to be done and what uplink physical channel to use for the reporting.

See Erik Dahlman et al., 5G NR: The Next Generation Wireless Access Technology, § 8.2 (2d Ed. 2018).

CSI-ReportConfig	
The IE <i>CSI-ReportConfig</i> is used to configure a periodic or semi-persistent report sent on PUCCH on the cell in which the <i>CSI-ReportConfig</i> is included, or to configure a semi-persistent or aperiodic report sent on PUSCH triggered by DCI received on the cell in which the <i>CSI-ReportConfig</i> is included (in this case, the cell on which the report is sent is determined by the received DCI). See TS 38.214 [19], clause 5.2.1.	
CSI-ReportConfig information element	
-- ASN1START	
-- TAG-CSI-REPORTCONFIG-START	
CSI-ReportConfig ::=	SEQUENCE {
reportConfigId	CSI-ReportConfigId,
carrier	ServCellIndex OPTIONAL, -- Need S
resourcesForChannelMeasurement	CSI-ResourceConfigId,
csi-IM-ResourcesForInterference	CSI-ResourceConfigId OPTIONAL, -- Need R
nzp-CSI-RS-ResourcesForInterference	CSI-ResourceConfigId OPTIONAL, -- Need R
reportConfigType	CHOICE {
periodic	SEQUENCE {
reportSlotConfig	CSI-ReportPeriodicityAndOffset,
pucch-CSI-ResourceList	SEQUENCE (SIZE (1..maxNrofBWPs)) OF PUCCH-CSI-Resource
},	
semiPersistentOnPUCCH	SEQUENCE {
reportSlotConfig	CSI-ReportPeriodicityAndOffset,
pucch-CSI-ResourceList	SEQUENCE (SIZE (1..maxNrofBWPs)) OF PUCCH-CSI-Resource
},	
semiPersistentOnPUSCH	SEQUENCE {
reportSlotConfig	ENUMERATED {s15, s110, s120, s140, s180, s1160, s1320},
reportSlotOffsetList	SEQUENCE (SIZE (1..maxNrofUL-Allocations)) OF INTEGER(0..32),
pAlpha	PO-PUSCH-AlphaSetId
},	
aperiodic	SEQUENCE {
reportSlotOffsetList	SEQUENCE (SIZE (1..maxNrofUL-Allocations)) OF INTEGER(0..32)
}	
}	
},	

See 3GPP TS 38.331 V15.15.0.



CSI-MeasConfig	
The IE <i>CSI-MeasConfig</i> is used to configure CSI-RS (reference signals) belonging to the serving cell in which <i>CSI-MeasConfig</i> is included, channel state information reports to be transmitted on PUCCH on the serving cell in which <i>CSI-MeasConfig</i> is included and channel state information reports on PUSCH triggered by DCI received on the serving cell in which <i>CSI-MeasConfig</i> is included. See also TS 38.214 [19], clause 5.2.	
CSI-MeasConfig information element	
-- ASN1START	
-- TAG-CSI-MEASCONFIG-START	
CSI-MeasConfig ::=	SEQUENCE {
nzp-CSI-RS-ResourceToAddModList	SEQUENCE (SIZE (1..maxNrofNZP-CSI-RS-Resources)) OF NZP-CSI-RS-Resource OPTIONAL, -- Need N
nzp-CSI-RS-ResourceToReleaseList	SEQUENCE (SIZE (1..maxNrofNZP-CSI-RS-Resources)) OF NZP-CSI-RS-ResourceId OPTIONAL, -- Need N
nzp-CSI-RS-ResourceSetToAddModList	SEQUENCE (SIZE (1..maxNrofNZP-CSI-RS-ResourceSets)) OF NZP-CSI-RS-ResourceSet OPTIONAL, -- Need N
nzp-CSI-RS-ResourceSetToReleaseList	SEQUENCE (SIZE (1..maxNrofNZP-CSI-RS-ResourceSets)) OF NZP-CSI-RS-ResourceSetId OPTIONAL, -- Need N
csi-IM-ResourceToAddModList	SEQUENCE (SIZE (1..maxNrofCSI-IM-Resources)) OF CSI-IM-Resource OPTIONAL, -- Need N
csi-IM-ResourceToReleaseList	SEQUENCE (SIZE (1..maxNrofCSI-IM-Resources)) OF CSI-IM-ResourceId OPTIONAL, -- Need N
csi-IM-ResourceSetToAddModList	SEQUENCE (SIZE (1..maxNrofCSI-IM-ResourceSets)) OF CSI-IM-ResourceSet OPTIONAL, -- Need N
csi-IM-ResourceSetToReleaseList	SEQUENCE (SIZE (1..maxNrofCSI-IM-ResourceSets)) OF CSI-IM-ResourceSetId OPTIONAL, -- Need N
csi-SSB-ResourceSetToAddModList	SEQUENCE (SIZE (1..maxNrofCSI-SSB-ResourceSets)) OF CSI-SSB-ResourceSet OPTIONAL, -- Need N
csi-SSB-ResourceSetToReleaseList	SEQUENCE (SIZE (1..maxNrofCSI-SSB-ResourceSets)) OF CSI-SSB-ResourceSetId OPTIONAL, -- Need N
csi-ResourceConfigToAddModList	SEQUENCE (SIZE (1..maxNrofCSI-ResourceConfigurations)) OF CSI-ResourceConfig OPTIONAL, -- Need N
csi-ResourceConfigToReleaseList	SEQUENCE (SIZE (1..maxNrofCSI-ResourceConfigurations)) OF CSI-ResourceConfigId OPTIONAL, -- Need N
csi-ReportConfigToAddModList	SEQUENCE (SIZE (1..maxNrofCSI-ReportConfigurations)) OF CSI-ReportConfig OPTIONAL, -- Need N
csi-ReportConfigToReleaseList	SEQUENCE (SIZE (1..maxNrofCSI-ReportConfigurations)) OF CSI-ReportConfigId OPTIONAL, -- Need N
reportTriggerSize	INTEGER (0..6) OPTIONAL, -- Need M
aperiodicTriggerStateList	SetupRelease { CSI-AperiodicTriggerStateList } OPTIONAL, -- Need M
semiPersistentOnPUSCH-TriggerStateList	SetupRelease { CSI-SemiPersistentOnPUSCH-TriggerStateList } OPTIONAL, -- Need M
...	
}	

See 3GPP TS 38.331 V15.15.0.

## 5.2 UE procedure for reporting channel state information (CSI)

### 5.2.1 Channel state information framework

The time and frequency resources that can be used by the UE to report CSI are controlled by the gNB. CSI may consist of Channel Quality Indicator (CQI), precoding matrix indicator (PMI), CSI-RS resource indicator (CRI), SS/PBCH Block Resource indicator (SSBRI), layer indicator (LI), rank indicator (RI) and/or L1-RSRP.

See 3GPP TS 38.214 V15.14.0.

#### 5.2.1.1 Reporting settings

Each Reporting Setting *CSI-ReportConfig* is associated with a single downlink BWP (indicated by higher layer parameter *BWP-Id*) given in the associated *CSI-ResourceConfig* for channel measurement and contains the parameter(s) for one CSI reporting band: codebook configuration including codebook subset restriction, time-domain behavior, frequency granularity for CQI and PMI, measurement restriction configurations, and the CSI-related quantities to be reported by the UE such as the layer indicator (LI), L1-RSRP, CRI, and SSBRI (SSB Resource Indicator).

The time domain behavior of the *CSI-ReportConfig* is indicated by the higher layer parameter *reportConfigType* and can be set to 'aperiodic', 'semiPersistentOnPUCCH', 'semiPersistentOnPUSCH', or 'periodic'. For periodic and semiPersistentOnPUCCH/semiPersistentOnPUSCH CSI reporting, the configured periodicity and slot offset applies in the numerology of the UL BWP in which the CSI report is configured to be transmitted on. The higher layer parameter *reportQuantity* indicates the CSI-related or L1-RSRP-related quantities to report. The *reportFreqConfiguration* indicates the reporting granularity in the frequency domain, including the CSI reporting band and if PMI/CQI reporting is wideband or sub-band. The *timeRestrictionForChannelMeasurements* parameter in *CSI-ReportConfig* can be configured to enable time domain restriction for channel measurements and *timeRestrictionForInterferenceMeasurements* can be configured to enable time domain restriction for interference measurements. The *CSI-ReportConfig* can also contain *CodebookConfig*, which contains configuration parameters for Type-I or Type II CSI including codebook subset restriction, and configurations of group based reporting.

See 3GPP TS 38.214 V15.14.0.

### 5.2.1.2 Resource settings

Each CSI Resource Setting *CSI-ResourceConfig* contains a configuration of a list of  $S \geq 1$  CSI Resource Sets (given by higher layer parameter *csi-RS-ResourceSetList*), where the list is comprised of references to either or both of NZP CSI-RS resource set(s) and SS/PBCH block set(s) or the list is comprised of references to CSI-IM resource set(s). Each CSI Resource Setting is located in the DL BWP identified by the higher layer parameter *BWP-id*, and all CSI Resource Settings linked to a CSI Report Setting have the same DL BWP.

The time domain behavior of the CSI-RS resources within a CSI Resource Setting are indicated by the higher layer parameter *resourceType* and can be set to aperiodic, periodic, or semi-persistent. For periodic and semi-persistent CSI Resource Settings, the number of CSI-RS Resource Sets configured is limited to  $S=1$ . For periodic and semi-persistent CSI Resource Settings, the configured periodicity and slot offset is given in the numerology of its associated DL BWP, as given by *BWP-id*. When a UE is configured with multiple *CSI-ResourceConfigs* consisting the same NZP CSI-RS resource ID, the same time domain behavior shall be configured for the *CSI-ResourceConfigs*. When a UE is configured with multiple *CSI-ResourceConfigs* consisting the same CSI-IM resource ID, the same time-domain behavior shall be configured for the *CSI-ResourceConfigs*. All CSI Resource Settings linked to a CSI Report Setting shall have the same time domain behavior.

The following are configured via higher layer signaling for one or more CSI Resource Settings for channel and interference measurement:

- CSI-IM resource for interference measurement as described in clause 5.2.2.4.
- NZP CSI-RS resource for interference measurement as described in clause 5.2.2.3.1.
- NZP CSI-RS resource for channel measurement as described in clause 5.2.2.3.1.

See 3GPP TS 38.214 V15.14.0.

### 7.4.1.5 CSI reference signals

#### 7.4.1.5.1 General

Zero-power (ZP) and non-zero-power (NZP) CSI-RS are defined

- for a non-zero-power CSI-RS configured by the *NZP-CSI-RS-Resource* IE or by the *CSI-RS-Resource-Mobility* field in the *CSI-RS-ResourceConfigMobility* IE, the sequence shall be generated according to clause 7.4.1.5.2 and mapped to resource elements according to clause 7.4.1.5.3
- for a zero-power CSI-RS configured by the *ZP-CSI-RS-Resource* IE, the UE shall assume that the resource elements defined in clause 7.4.1.5.3 are not used for PDSCH transmission subject to clause 5.1.4.2 of [6, TS 38.214]. The UE performs the same measurement/reception on channels/signals except PDSCH regardless of whether they collide with ZP CSI-RS or not.

See 3GPP TS 38.211 V15.9.0.

19. Claim 9 of the '780 Patent recites that the "controller" is configured to "determine a type of the received interference from among a plurality of interference types comprising wideband interference, self interference, and narrowband interference based upon comparing at least one characteristic of a current received signal with the short term and long term historical characteristics of interference." The Accused Products each comprise a controller configured to determine a type of the received interference from among a plurality of interference types comprising wideband interference, self interference, and narrowband interference based upon comparing at least one characteristic of a current received signal with the short term and long term

historical characteristics of interference. For example, the channel state information – reference signal (“CSI-RS”) and channel state information – interference measurement (“CSI-IM”) resource sets may be specified across the entire bandwidth-part or just a part of the bandwidth that the UE is configured to receive:

### 8.1.2: Frequency-Domain Structure of CSI-RS Configurations

A CSI-RS is configured for a given downlink bandwidth part and is then assumed to be confined within that bandwidth part and use the numerology of the bandwidth part.

The CSI-RS can be configured to cover the full bandwidth of the bandwidth part or just a fraction of the bandwidth. In the latter case, the CSI-RS bandwidth and frequency-domain starting position are provided as part of the CSI-RS configuration.

Within the configured CSI-RS bandwidth, a CSI-RS may be configured for transmission in every resource block, referred to as *CSI-RS density equal to one*. However, a CSI-RS may also be configured for transmission only in every second resource block, referred to as *CSI-RS density equal to 1/2*. In the latter case, the CSI-RS configuration includes information about the set of resource blocks (odd resource blocks or even resource blocks) within which the CSI-RS will be transmitted. CSI-RS density equal to 1/2 is not supported for CSI-RS with 4, 8, and 12 antenna ports.

See Erik Dahlman et al., 5G NR: The Next Generation Wireless Access Technology, § 8.1.2 (2d Ed. 2018).

★ The parameter structure used to configure a CSI IM Resource is presented in Table 125. This parameter structure includes a CSI IM Resource identity and a specification of the resources which are allocated to the CSI IM Resource. There is a choice of configuring either pattern 0 or pattern 1:

- Pattern 0 corresponds to a 2×2 grid of Resource Elements. *subcarrierLocation-p0* and *symbolLocation-p0* specify the first subcarrier and first symbol belonging to the 2×2 grid
- Pattern 1 corresponds to a 4×1 grid of Resource Elements (4 subcarriers × 1 symbol). *subcarrierLocation-p1* and *symbolLocation-p1* specify the first subcarrier and the only symbol belonging to the 4×1 grid

Examples of patterns 0 and 1 are illustrated in Figure 199

CSI-IM-Resource					
csi-IM-ResourceId	0 to 31				
csi-IM-ResourceElementPattern	CHOICE				
	pattern0		pattern1		
	subcarrierLocation-p0	0, 2, 4, 6, 8 10	subcarrierLocation-p1	0, 4, 8	
	symbolLocation-p0	0 to 12	symbolLocation-p1	0 to 13	
freqBand	startingRB	0 to 274, step 4			
	nrofRBs	24 to 276, step 4			
periodicityAndOffset	CHOICE				
	4 slots	0 to 3	20 slots	0 to 19	160 slots 0 to 159
	5 slots	0 to 4	32 slots	0 to 31	320 slots 0 to 319
	8 slots	0 to 7	40 slots	0 to 39	640 slots 0 to 639
	10 slots	0 to 9	64 slots	0 to 63	
	16 slots	0 to 15	80 slots	0 to 79	

Table 125 – Parameter structure used to configure a CSI IM Resource

★ The *freqBand* section of the parameter structure specifies the set of contiguous Resource Blocks across which the CSI IM Resource is configured. The *startingRB* is relative to Common Resource Block 0, i.e. the lower edge of the channel bandwidth, rather than the lower edge of the Bandwidth Part. The *nrofRBs* information element has a minimum value of 24 but if the Bandwidth Part occupies less than 24 Resource Blocks then the CSI IM Resource occupies only the Resource Blocks within the Bandwidth Part

See Chris Johnson, 5G New Radio in Bullets, Section 3.7.4. (2019).

```

-- NQP-CSI-RS-Resource

The IE NQP-CSI-RS-Resource is used to configure Non-Zero-Power (NQP) CSI-RS transmitted in the cell where the IE is included, which the UE may be configured to measure on (see TS 38.214 [19], clause 5.2.2.3.1). A change of configuration between periodic, semi-persistent or aperiodic for an NQP-CSI-RS-Resource is not supported without a release and add.

NQP-CSI-RS-Resource information element

-- ASN1START
-- TAG-NQP-CSI-RS-RESOURCE-START

NQP-CSI-RS-Resource ::= SEQUENCE {
    nqp-CSI-RS-ResourceId          NQP-CSI-RS-ResourceId,
    resourceMapping               CSI-RS-ResourceMapping,
    powerControlOffset            INTEGER (-8..15),
    powerControlOffsetSS          ENUMERATED{db-3, db0, db3, db6} OPTIONAL, -- Need R
    scramblingID                 ScramblingId,
    periodicityAndOffset          CSI-ResourcePeriodicityAndOffset OPTIONAL, -- Cond PeriodicOrSemiPersistent
    qcl-InfoPeriodicCSI-RS       TCI-StateId OPTIONAL, -- Cond Periodic
    ...
}
    
```

See 3GPP TS 38.331 V 15.15.0.



```

--
-- CSI-IM-Resource
--
The IE CSI-IM-Resource is used to configure one CSI Interference Management (IM) resource.

CSI-IM-Resource information element

-- ASN1START
-- TAG-CSI-IM-RESOURCE-START
CSI-IM-Resource ::= SEQUENCE {
  csi-IM-ResourceId          CSI-IM-ResourceId,
  csi-IM-ResourceElementPattern CHOICE {
    pattern0 SEQUENCE {
      subcarrierLocation-p0  ENUMERATED { s0, s2, s4, s6, s8, s10 },
      symbolLocation-p0      INTEGER (0..12)
    },
    pattern1 SEQUENCE {
      subcarrierLocation-p1  ENUMERATED { s0, s4, s8 },
      symbolLocation-p1      INTEGER (0..13)
    }
  }
}
freqBand                    CSI-FrequencyOccupation          OPTIONAL, -- Need M
periodicityAndOffset       CSI-ResourcePeriodicityAndOffset OPTIONAL, -- Need M
...                         OPTIONAL, -- Cond PeriodicOrSemiPersistent
}

```

See 3GPP TS 38.331 V 15.15.0.

### 5.2.2.3.1 NZP CSI-RS

The UE can be configured with one or more NZP CSI-RS resource set configuration(s) as indicated by the higher layer parameters *CSI-ResourceConfig*, and *NZP-CSI-RS-ResourceSet*. Each NZP CSI-RS resource set consists of  $K \geq 1$  NZP CSI-RS resource(s).

The following parameters for which the UE shall assume non-zero transmission power for CSI-RS resource are configured via the higher layer parameter *NZP-CSI-RS-Resource*, *CSI-ResourceConfig* and *NZP-CSI-RS-ResourceSet* for each CSI-RS resource configuration:

- *nzp-CSI-RS-ResourceId* determines CSI-RS resource configuration identity.
- *periodicityAndOffset* defines the CSI-RS periodicity and slot offset for periodic/semi-persistent CSI-RS. All the CSI-RS resources within one set are configured with the same periodicity, while the slot offset can be same or different for different CSI-RS resources.
- *resourceMapping* defines the number of ports, CDM-type, and OFDM symbol and subcarrier occupancy of the CSI-RS resource within a slot that are given in clause 7.4.1.5 of [4, TS 38.211].
- *nrofPorts* in *resourceMapping* defines the number of CSI-RS ports, where the allowable values are given in clause 7.4.1.5 of [4, TS 38.211].
- *density* in *resourceMapping* defines CSI-RS frequency density of each CSI-RS port per PRB, and CSI-RS PRB offset in case of the density value of 1/2, where the allowable values are given in clause 7.4.1.5 of [4, TS 38.211]. For density 1/2, the odd/even PRB allocation indicated in *density* is with respect to the common resource block grid.
- *cdm-Type* in *resourceMapping* defines CDM values and pattern, where the allowable values are given in clause 7.4.1.5 of [4, TS 38.211].
- *powerControlOffset*: which is the assumed ratio of PDSCH EPRE to NZP CSI-RS EPRE when UE derives CSI feedback and takes values in the range of [-8, 15] dB with 1 dB step size.
- *powerControlOffsetSS*: which is the assumed ratio of NZP CSI-RS EPRE to SS/PBCH block EPRE.
- *scramblingID* defines scrambling ID of CSI-RS with length of 10 bits.
- *BWP-Id* in *CSI-ResourceConfig* defines which bandwidth part the configured CSI-RS is located in.
- *repetition* in *NZP-CSI-RS-ResourceSet* is associated with a CSI-RS resource set and defines whether UE can assume the CSI-RS resources within the NZP CSI-RS Resource Set are transmitted with the same downlink spatial domain transmission filter or not as described in clause 5.1.6.1.2. and can be configured only when the

higher layer parameter *reportQuantity* associated with all the reporting settings linked with the CSI-RS resource set is set to 'cri-RSRP' or 'none'.

- *qcl-InfoPeriodicCSI-RS* contains a reference to a *TCI-State* indicating QCL source RS(s) and QCL type(s). If the *TCI-State* is configured with a reference to an RS with 'QCL-TypeD' association, that RS may be an SS/PBCH block located in the same or different CC/DL BWP or a CSI-RS resource configured as periodic located in the same or different CC/DL BWP.
- *trs-Info* in *NZP-CSI-RS-ResourceSet* is associated with a CSI-RS resource set and for which the UE can assume that the antenna port with the same port index of the configured NZP CSI-RS resources in the *NZP-CSI-RS-ResourceSet* is the same as described in clause 5.1.6.1.1 and can be configured when reporting setting is not configured or when the higher layer parameter *reportQuantity* associated with all the reporting settings linked with the CSI-RS resource set is set to 'none'.

See 3GPP TS 38.214 V15.14.0.

All CSI-RS resources within one set are configured with same *density* and same *nrofPorts*, except for the NZP CSI-RS resources used for interference measurement.

The UE expects that all the CSI-RS resources of a resource set are configured with the same starting RB and number of RBs and the same *cdm-type*.

The bandwidth and initial common resource block (CRB) index of a CSI-RS resource within a BWP, as defined in clause 7.4.1.5 of [4, TS 38.211], are determined based on the higher layer parameters *nrofRBs* and *startingRB*, respectively, within the CSI-FrequencyOccupation IE configured by the higher layer parameter *freqBand* within the *CSI-RS-ResourceMapping* IE. Both *nrofRBs* and *startingRB* are configured as integer multiples of 4 RBs, and the reference point for *startingRB* is CRB 0 on the common resource block grid. If  $startingRB < N_{BWP}^{start}$ , the UE shall assume that the initial CRB index of the CSI-RS resource is  $N_{initial\ RB} = N_{BWP}^{start}$ , otherwise  $N_{initial\ RB} = startingRB$ .

If  $nrofRBs > N_{BWP}^{size} + N_{BWP}^{start} - N_{initial\ RB}$ , the UE shall assume that the bandwidth of the CSI-RS resource is  $N_{CSI-RS}^{BW} = N_{BWP}^{size} + N_{BWP}^{start} - N_{initial\ RB}$ , otherwise  $N_{CSI-RS}^{BW} = nrofRBs$ . In all cases, the UE shall expect that  $N_{CSI-RS}^{BW} \geq \min(24, N_{BWP}^{size})$ .

See 3GPP TS 38.214 V15.14.0.

#### 5.2.2.4 Channel State Information – Interference Measurement (CSI-IM)

The UE can be configured with one or more CSI-IM resource set configuration(s) as indicated by the higher layer parameter *CSI-IM-ResourceSet*. Each CSI-IM resource set consists of  $K \geq 1$  CSI-IM resource(s).

The following parameters are configured via higher layer parameter *CSI-IM-Resource* for each CSI-IM resource configuration:

- *csi-IM-ResourceId* determines CSI-IM resource configuration identity
- *subcarrierLocation-p0* or *subcarrierLocation-p1* defines subcarrier occupancy of the CSI-IM resource within a slot for *csi-IM-ResourceElementPattern* set to 'pattern0' or 'pattern1', respectively.
- *symbolLocation-p0* or *symbolLocation-p1* defines OFDM symbol location of the CSI-IM resource within a slot for *csi-IM-ResourceElementPattern* set to 'pattern0' or 'pattern1', respectively.
- *periodicityAndOffset* defines the CSI-IM periodicity and slot offset for periodic/semi-persistent CSI-IM.
- *freqBand* includes parameters to enable configuration of frequency-occupancy of CSI-IM

In each of the PRBs configured by *freqBand*, the UE shall assume each CSI-IM resource is located in,

- resource elements  $(k_{CSI-IM}, l_{CSI-IM}), (k_{CSI-IM}, l_{CSI-IM} + 1), (k_{CSI-IM} + 1, l_{CSI-IM})$  and  $(k_{CSI-IM} + 1, l_{CSI-IM} + 1)$ , if *csi-IM-ResourceElementPattern* is set to 'pattern0',
- resource elements  $(k_{CSI-IM}, l_{CSI-IM}), (k_{CSI-IM} + 1, l_{CSI-IM}), (k_{CSI-IM} + 2, l_{CSI-IM})$  and  $(k_{CSI-IM} + 3, l_{CSI-IM})$  if *csi-IM-ResourceElementPattern* is set to 'pattern1',

where  $k_{CSI-IM}$  and  $l_{CSI-IM}$  are the configured frequency-domain location and time-domain location, respectively, given by the higher layer parameters in the above list.

See 3GPP TS 38.214 V15.14.0.

For example, channel measurements are based upon either multiple in time or single time readings.

## 5.2.2 Channel state information

### 5.2.2.1 Channel quality indicator (CQI)

The CQI indices and their interpretations are given in Table 5.2.2.1-2 or Table 5.2.2.1-4 for reporting CQI based on QPSK, 16QAM and 64QAM. The CQI indices and their interpretations are given in Table 5.2.2.1-3 for reporting CQI based on QPSK, 16QAM, 64QAM and 256QAM.

Based on an unrestricted observation interval in time unless specified otherwise in this clause, and an unrestricted observation interval in frequency, the UE shall derive for each CQI value reported in uplink slot  $n$  the highest CQI index which satisfies the following condition:

- A single PDSCH transport block with a combination of modulation scheme, target code rate and transport block size corresponding to the CQI index, and occupying a group of downlink physical resource blocks termed the CSI reference resource, could be received with a transport block error probability not exceeding:
  - 0.1, if the higher layer parameter *cqi-Table* in *CSI-ReportConfig* configures 'table1' (corresponding to Table 5.2.2.1-2), or 'table2' (corresponding to Table 5.2.2.1-3), or
  - 0.00001, if the higher layer parameter *cqi-Table* in *CSI-ReportConfig* configures 'table3' (corresponding to Table 5.2.2.1-4).

If higher layer parameter *timeRestrictionForChannelMeasurements* is set to "notConfigured", the UE shall derive the channel measurements for computing CSI value reported in uplink slot  $n$  based on only the NZP CSI-RS, no later than the CSI reference resource, (defined in TS 38.211[4]) associated with the CSI resource setting.

If higher layer parameter *timeRestrictionForChannelMeasurements* in *CSI-ReportConfig* is set to "Configured", the UE shall derive the channel measurements for computing CSI reported in uplink slot  $n$  based on only the most recent, no later than the CSI reference resource, occasion of NZP CSI-RS (defined in [4, TS 38.211]) associated with the CSI resource setting.

If higher layer parameter *timeRestrictionForInterferenceMeasurements* is set to "notConfigured", the UE shall derive the interference measurements for computing CSI value reported in uplink slot  $n$  based on only the CSI-IM and/or NZP CSI-RS for interference measurement no later than the CSI reference resource associated with the CSI resource setting.

If higher layer parameter *timeRestrictionForInterferenceMeasurements* in *CSI-ReportConfig* is set to "Configured", the UE shall derive the interference measurements for computing the CSI value reported in uplink slot  $n$  based on the most recent, no later than the CSI reference resource, occasion of CSI-IM and/or NZP CSI-RS for interference measurement (defined in [4, TS 38.211]) associated with the CSI resource setting.

See 3GPP TS 38.214 §5.2.2.1.

For example, rank indicator ("RI") and pre-coding matrix indicator ("PMI") are also computed based on SRS measurements.

To select a suitable rank and a corresponding precoder matrix, the network needs estimates of the channels between the device antenna ports and the corresponding network receive antennas. To enable this, a device configured for codebook-based PUSCH would typically be configured for transmission of at least one multi-port SRS. Based on measurements on the configured SRS, the network can sound the channel and determine a suitable rank and precoder matrix.

See Erik Dahlman et al., 5G NR: The Next Generation Wireless Access Technology, § 11.3.1 (2d Ed. 2018).

20. Claim 9 of the '780 Patent recites that the “controller” is configured to “set the at least one settable link characteristic to compensate for the received interference based upon the interference type.” The Accused Products each comprise a controller configured to set the at least one settable link characteristic to compensate for the received interference based upon the interference type. For example, the Accused Products report at least wideband and subband CQI, wideband and subband PMI, and also RI:

- wideband CQI or subband CQI reporting, as configured by the higher layer parameter *cqi-FormatIndicator*. When wideband CQI reporting is configured, a wideband CQI is reported for each codeword for the entire CSI reporting band. When subband CQI reporting is configured, one CQI for each codeword is reported for each subband in the CSI reporting band.

See 3GPP TS 38.214 V.15.14.0 §5.2.1.4.

wideband PMI or subband PMI reporting as configured by the higher layer parameter *pmi-FormatIndicator*. When wideband PMI reporting is configured, a wideband PMI is reported for the entire CSI reporting band. When subband PMI reporting is configured, except with 2 antenna ports, a single wideband indication ( $i_1$  in clause 5.2.2.2) is reported for the entire CSI reporting band and one subband indication ( $i_2$  in clause 5.2.2.2) is reported for each subband in the CSI reporting band. When subband PMIs are configured with 2 antenna ports, a PMI is reported for each subband in the CSI reporting band.

See 3GPP TS 38.214 V.15.14.0 §5.2.1.4.



### 5.2.2.1 Channel quality indicator (CQI)

The CQI indices and their interpretations are given in Table 5.2.2.1-2 or Table 5.2.2.1-4 for reporting CQI based on QPSK, 16QAM and 64QAM. The CQI indices and their interpretations are given in Table 5.2.2.1-3 for reporting CQI based on QPSK, 16QAM, 64QAM and 256QAM.

Based on an unrestricted observation interval in time unless specified otherwise in this clause, and an unrestricted observation interval in frequency, the UE shall derive for each CQI value reported in uplink slot  $n$  the highest CQI index which satisfies the following condition:

- A single PDSCH transport block with a combination of modulation scheme, target code rate and transport block size corresponding to the CQI index, and occupying a group of downlink physical resource blocks termed the CSI reference resource, could be received with a transport block error probability not exceeding:
  - 0.1, if the higher layer parameter *cqi-Table* in *CSI-ReportConfig* configures 'table1' (corresponding to Table 5.2.2.1-2), or 'table2' (corresponding to Table 5.2.2.1-3), or
  - 0.00001, if the higher layer parameter *cqi-Table* in *CSI-ReportConfig* configures 'table3' (corresponding to Table 5.2.2.1-4).

If higher layer parameter *timeRestrictionForChannelMeasurements* is set to "notConfigured", the UE shall derive the channel measurements for computing CSI value reported in uplink slot  $n$  based on only the NZP CSI-RS, no later than the CSI reference resource, (defined in TS 38.211[4]) associated with the CSI resource setting.

If higher layer parameter *timeRestrictionForChannelMeasurements* in *CSI-ReportConfig* is set to "Configured", the UE shall derive the channel measurements for computing CSI reported in uplink slot  $n$  based on only the most recent, no later than the CSI reference resource, occasion of NZP CSI-RS (defined in [4, TS 38.211]) associated with the CSI resource setting.

If higher layer parameter *timeRestrictionForInterferenceMeasurements* is set to "notConfigured", the UE shall derive the interference measurements for computing CSI value reported in uplink slot  $n$  based on only the CSI-IM and/or NZP CSI-RS for interference measurement no later than the CSI reference resource associated with the CSI resource setting.

See 3GPP TS 38.214 V.15.14.0.

The bitwidth for RI/LI/CQI/CRI of *codebookType=typeI-SinglePanel* is provided in Tables 6.3.1.1.2-3.

**Table 6.3.1.1.2-3: RI, LI, CQI, and CRI of *codebookType=typeI-SinglePanel***

Field	Bitwidth				
	1 antenna port	2 antenna ports	4 antenna ports	>4 antenna ports	
				Rank1~4	Rank5~8
Rank Indicator	0	$\min(1, \lceil \log_2 n_{\text{RI}} \rceil)$	$\min(2, \lceil \log_2 n_{\text{RI}} \rceil)$	$\lceil \log_2 n_{\text{RI}} \rceil$	$\lceil \log_2 n_{\text{RI}} \rceil$
Layer Indicator	0	$\lceil \log_2 v \rceil$	$\min(2, \lceil \log_2 v \rceil)$	$\min(2, \lceil \log_2 v \rceil)$	$\min(2, \lceil \log_2 v \rceil)$
Wide-band CQI for the first TB	4	4	4	4	4
Wideband CQI for the second TB	0	0	0	0	4
Subband differential CQI for the first TB	2	2	2	2	2
Subband differential CQI for the second TB	0	0	0	0	2
CRI	$\lceil \log_2 (K_s^{\text{CSI-RS}}) \rceil$	$\lceil \log_2 (K_s^{\text{CSI-RS}}) \rceil$	$\lceil \log_2 (K_s^{\text{CSI-RS}}) \rceil$	$\lceil \log_2 (K_s^{\text{CSI-RS}}) \rceil$	$\lceil \log_2 (K_s^{\text{CSI-RS}}) \rceil$

$n_{\text{RI}}$  in Table 6.3.1.1.2-3 is the number of allowed rank indicator values according to Clause 5.2.2.2.1 [6, TS 38.214].

$v$  is the value of the rank. The value of  $K_s^{\text{CSI-RS}}$  is the number of CSI-RS resources in the corresponding resource set.

The values of the rank indicator field are mapped to allowed rank indicator values with increasing order, where '0' is mapped to the smallest allowed rank indicator value.

See 3GPP TS 38.212 V15.12.0 §6.3.1.1.2.

21. Samsung also knowingly and intentionally induces infringement of one or more claims of the '780 Patent in violation of 35 U.S.C. § 271(b). As of at least the filing and service of this complaint, Samsung has knowledge of the '780 Patent and the infringing nature of the Accused Products. Despite this knowledge of the '780 Patent, Samsung continues to actively encourage and instruct its customers and end users (for example, through user manuals and online instruction materials on its website) to use the Accused Products in ways that directly infringe the '780 Patent, for example by utilizing the accused 5G functionality on the Accused Products in an infringing manner. See, e.g., [https://downloadcenter.samsung.com/content/PM/202101/20210129215516972/EB/SAM\\_G991U\\_G996U\\_G998U\\_EN\\_FINAL\\_210122/start\\_here.html](https://downloadcenter.samsung.com/content/PM/202101/20210129215516972/EB/SAM_G991U_G996U_G998U_EN_FINAL_210122/start_here.html) (Samsung S21 5G Series User Manual). Further, Samsung advertises to customers that a “key feature” of the Galaxy S21 Ultra 5G is that it is “5G ready.” <https://www.samsung.com/us/business/support/owners/product/galaxy-s21-ultra-5g-unlocked/>. Samsung provides these instructions and online materials to customers and end users knowing and intending (or with willful blindness to the fact) that its customers and end users will commit these infringing acts. Samsung also continues to make, use, offer for sale, sell, and/or import the Accused Products, despite its knowledge of the '780 Patent, thereby specifically intending for and inducing its customers to infringe the '780 Patent through the customers' normal and customary use of the Accused Products.

22. Samsung has also infringed, and continues to infringe, one or more claims of the '780 Patent by selling, offering for sale, or importing into the United States, the Accused Products, knowing that the Accused Products constitute a material part of the inventions claimed in the '780 Patent, are especially made or adapted to infringe the '780 Patent, and are not staple

articles or commodities of commerce suitable for non-infringing use (as exemplified by the materials cited above). As of at least the filing and service of this complaint, Samsung has knowledge of the '780 Patent and the infringing nature of the Accused Products. Samsung has been, and currently is, contributorily infringing the '780 Patent in violation of 35 U.S.C. §§ 271(c) and (f).

23. By making, using, offering for sale, selling and/or importing into the United States the Accused Products, Samsung has injured Plaintiff and is liable for infringement of the '780 Patent pursuant to 35 U.S.C. § 271.

24. As a result of Samsung's infringement of the '780 Patent, Plaintiff is entitled to monetary damages (past, present, and future) in an amount adequate to compensate for Samsung's infringement, but in no event less than a reasonable royalty for the use made of the invention by Samsung, together with interest and costs as fixed by the Court.

## **COUNT II**

### **INFRINGEMENT OF U.S. PATENT NO. 7,110,779**

25. Plaintiff realleges and incorporates by reference the foregoing paragraphs as if fully set forth herein.

26. Samsung has been and is now directly infringing the '779 Patent, literally and/or under the doctrine of equivalents, in violation of 35 U.S.C. § 271(a), including by making, using, selling, and/or offering for sale in the United States or importing into the United States infringing products and systems, including at least the Accused Products identified above. The Accused Products satisfy all of the claim limitations of one or more claims of the '779 Patent, including but not limited to claim 18.



27. Claim 18 of the '779 Patent recites “[a] wireless device locator for locating a target wireless communications device having a unique identifier (UID) associated therewith.” To the extent the preamble is limiting, the Accused Products each comprise a wireless device locator for locating a target wireless communications device having a unique identifier (UID) associated therewith. For example, the accused Samsung Galaxy S21 Ultra supports ultra-wideband (“UWB”) functionality for locating a target wireless communications device, such as the Samsung Galaxy SmartTag+:

Network & Connectivity	Galaxy S21 5G and S21+ 5G	Galaxy S21 Ultra 5G
	<b>5G</b> 5G Non-Standalone (NSA), Standalone (SA), Sub6 / mmWave	<b>5G</b> 5G Non-Standalone (NSA), Standalone (SA), Sub6 / mmWave
	<b>LTE</b> Enhanced 4x4 MIMO, Up to 7CA, LTE Cat.20 Up to 2.0Gbps Download / Up to 200Mbps Upload	<b>LTE</b> Enhanced 4x4 MIMO, Up to 7CA, LTE Cat.20 Up to 2.0Gbps Download / Up to 200Mbps Upload
	<b>Wi-Fi</b> Wi-Fi 802.11 a/b/g/n/ac/ax 2.4G+5GHz, HE80, MIMO, 1024-QAM Up to 1.2Gbps Download / Up to 1.2Gbps Upload	<b>Wi-Fi</b> Wi-Fi 802.11 a/b/g/n/ac/ax 2.4G+5GHz+6GHz, HE160, MIMO, 1024-QAM Up to 2.4Gbps Download / Up to 2.4Gbps Upload
	<b>Bluetooth</b> Bluetooth® v 5.0, USB type-C, NFC, Location (GPS, Galileo, Glonass, BeiDou)	<b>Bluetooth</b> Bluetooth® v 5.2, USB type-C, NFC, Location (GPS, Galileo, Glonass, BeiDou)
	<b>Ultra Wide Band</b>	<b>Ultra Wide Band</b>

See <https://www.samsung.com/global/galaxy/galaxy-s21-ultra-5g/specs/>.



**Locate your belongings visually with new AR Finder technology**

Because Galaxy SmartTag+ is both BLE- and UWB-enabled, you can now use AR technology to find your missing item[5]. The AR Finder guides you with an easy-to-follow interface on your UWB-equipped smartphone, such as Galaxy S21+ or S21 Ultra, which shows you how far away you are from your Galaxy SmartTag+ and points you in its direction. And once you're closer to the tag's location, you can choose to have it produce a loud ring so that even if it's slipped under the sofa, you'll have no trouble finding it.

See <https://news.samsung.com/us/introducing-the-new-galaxy-smarttag-plus/>.

28. Claim 18 of the '779 Patent recites "at least one antenna and a transceiver connected thereto." The Accused Products comprise at least one antenna and a transceiver connected thereto. For example, the Samsung S21 Ultra comprises at least one antenna and a transceiver:

Network & Connectivity	Galaxy S21 5G and S21+ 5G	Galaxy S21 Ultra 5G
	<b>5G</b> 5G Non-Standalone (NSA), Standalone (SA), Sub6 / mmWave	<b>5G</b> 5G Non-Standalone (NSA), Standalone (SA), Sub6 / mmWave
	<b>LTE</b> Enhanced 4x4 MIMO, Up to 7CA, LTE Cat.20 Up to 2.0Gbps Download / Up to 200Mbps Upload	<b>LTE</b> Enhanced 4x4 MIMO, Up to 7CA, LTE Cat.20 Up to 2.0Gbps Download / Up to 200Mbps Upload
	<b>Wi-Fi</b> Wi-Fi 802.11 a/b/g/n/ac/ax 2.4G+5GHz, HE80, MIMO, 1024-QAM Up to 1.2Gbps Download / Up to 1.2Gbps Upload	<b>Wi-Fi</b> Wi-Fi 802.11 a/b/g/n/ac/ax 2.4G+5GHz+6GHz, HE160, MIMO, 1024-QAM Up to 2.4Gbps Download / Up to 2.4Gbps Upload
	<b>Bluetooth</b> Bluetooth® v 5.0, USB type-C, NFC, Location (GPS, Galileo, Glonass, BeiDou)	<b>Bluetooth</b> Bluetooth® v 5.2, USB type-C, NFC, Location (GPS, Galileo, Glonass, BeiDou)
	Ultra Wide Band	Ultra Wide Band

See <https://www.samsung.com/global/galaxy/galaxy-s21-ultra-5g/specs/>.



## **NXP's Trimension™ Ultra-Wideband Technology Helps Samsung Users Easily Find Their Misplaced Belongings**

***NXP's UWB and Bluetooth® technologies work together to provide greater location accuracy for Samsung Galaxy SmartTag+***

**COMPUTEX, Taipei, Taiwan, June 2, 2021** – NXP Semiconductors announced that its Trimension Ultra-Wideband platform now offers fine ranging for new tagging use cases. UWB and Bluetooth® Low Energy solutions have been combined to deliver spatial awareness to the new Samsung Galaxy SmartTag+, providing an enhanced experience to the Samsung SmartThings Find service.

See <https://www.nxp.com/docs/en/supporting-information/NXPs-TrimensionTM-Ultra-Wideband-Technology-Helps-Samsung-Users-Easily-Find-Their-M.pdf>.

## FiRa Certified Devices

The FiRa Certified™ logo can now be proudly displayed on the following devices\*:

	Company Name	Device Name	Device Type	Certification	Date Certified
	NXP	Trimension SR150	Chipset	Base	October 27, 2021
	NXP	Trimension SR040	Chipset	Base	October 27, 2021
	Samsung	Galaxy S21 Ultra 5G	Smartphone	Base	October 27, 2021

\*Please note that this may not represent a full listing of FiRa Certified devices; some organizations may choose to not have their devices listed.

See <https://www.firaconsortium.org/certifications/certified-devices>.

29. Claim 18 of the '779 Patent recites “a controller for” “cooperating with said transceiver for transmitting a plurality of location finding signals to the target wireless communications device, inserting the UID for the target wireless communications device in each of the location finding signals, and receiving a respective reply signal for each of said location finding signals generated by the target wireless communications device based upon the UID in the location finding signals.” The Accused Products comprise a controller for cooperating with said transceiver for transmitting a plurality of location finding signals to the target wireless communications device, inserting the UID for the target wireless communications device in each of the location finding signals, and receiving a respective reply signal for each of said location finding signals generated by the target wireless communications device based upon the UID in the location finding signals. For example, the Samsung S21 Ultra comprises a controller that cooperates with a transceiver and includes a UID for the target wireless communications device (such as a Samsung Galaxy SmartTag+) in location finding signals:

## SmartTag+ AR finding ▼

**Note:** The Samsung Galaxy SmartTag+ is compatible with Android OS 8.0 or higher. However, to use the AR finding feature, your Galaxy phone or tablet must support Android 11 or higher. The feature is currently available on Note 20 Ultra, S21+, S21 Ultra, and Z Fold 2. iOS devices and third-party Android devices are not supported.

The SmartTag+ is similar to the SmartTag, but it also offers augmented reality (AR) finding via Ultra-wideband technology. This feature uses your phone's camera to track the precise location of the SmartTag+ within 15 meters, making it useful if you lost an item at home or nearby.

1. Once you've connected the SmartTag+ to the SmartThings app on your phone or tablet, open the app, and then tap the **Life** tab. Tap the **SmartThings Find** card.
2. Make sure you've selected your SmartTag+, and then tap **Search nearby**.
3. Wait a few seconds, and then tap **Find using camera**.  
**Note:** The Find using camera option may not appear if the signal is too weak.
4. You may need to grant permissions before opening the camera. Next, point your device around your current area.
5. If the signal is strong enough, you may see arrows on the screen pointing you in the right direction as you approach the SmartTag+.



6. Tap the **music note** icon to make the SmartTag+ ring, so it's easier to find.
7. If you get close enough to the SmartTag+ and missing item, a popup message will appear, informing you that it's nearby.

See <https://www.samsung.com/us/support/answer/ANS00088244/>.

## FiRa Certified Devices

The FiRa Certified™ logo can now be proudly displayed on the following devices\*:

Company Name	Device Name	Device Type	Certification	Date Certified	
	NXP	Trimension SR150	Chipset	Base	October 27, 2021
	NXP	Trimension SR040	Chipset	Base	October 27, 2021
Samsung	Galaxy S21 Ultra 5G	Smartphone	Base	October 27, 2021	

\*Please note that this may not represent a full listing of FiRa Certified devices; some organizations may choose to not have their devices listed.

See <https://www.firaconsortium.org/certifications/certified-devices>.

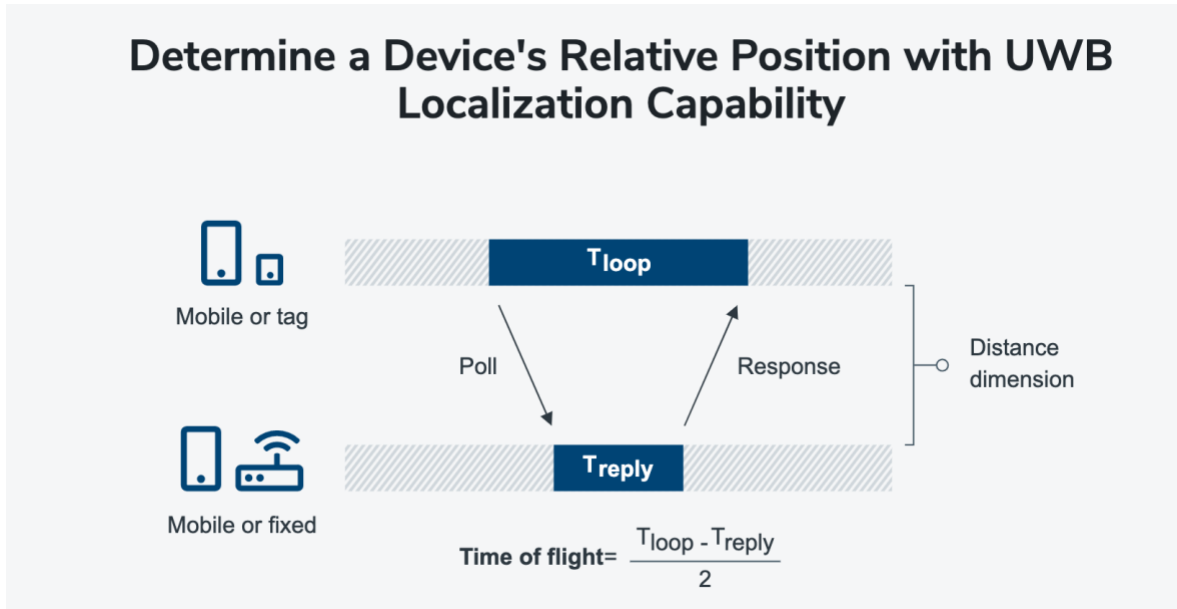

See <https://www.nxp.com/applications/enabling-technologies/connectivity/ultra-wideband-uwband:UWB>.

## 7.2 General MAC frame format

### 7.2.1 General

The general MAC frame for Frame Type values other than fragment and extended, as defined in Table 7-1, shall be formatted as illustrated in Figure 7-1.

Octets: 1/2	0/1	0/2	0/2/8	0/2	0/2/8	variable	variable		variable	2/4
Frame Control	Sequence Number	Destination PAN ID	Destination Address	Source PAN ID	Source Address	Auxiliary Security Header	IE		Frame Payload	FCS
		Addressing fields					Header IEs	Payload IEs		
MHR							MAC Payload			MFR

Figure 7-1—General MAC frame format

See IEEE 802.15.4z-2020 - IEEE Standard for Low-Rate Wireless Networks—Amendment 1: Enhanced Ultra Wideband (UWB) Physical Layers (PHYs) and Associated Ranging Techniques at Section 7.2.1.

30. Claim 18 of the '779 Patent recites a “controller for” “determining a propagation delay associated with the transmission of each location finding signal and the respective reply signal therefor based upon a known device latency of the target wireless communications device.” The Accused Products comprise a controller for determining a propagation delay associated with the transmission of each location finding signal and the respective reply signal therefor based upon a known device latency of the target wireless communications device. For example, the Samsung S21 Ultra comprises a controller for determining a propagation delay associated with the transmission of each location finding signal and the respective reply signal therefor based upon a known device latency of the target wireless communications device (such as a Samsung Galaxy SmartTag+):

#### SmartTag+ AR finding ▼

**Note:** The Samsung Galaxy SmartTag+ is compatible with Android OS 8.0 or higher. However, to use the AR finding feature, your Galaxy phone or tablet must support Android 11 or higher. The feature is currently available on Note 20 Ultra, S21+, S21 Ultra, and Z Fold 2. iOS devices and third-party Android devices are not supported.

The SmartTag+ is similar to the SmartTag, but it also offers augmented reality (AR) finding via Ultra-wideband technology. This feature uses your phone's camera to track the precise location of the SmartTag+ within 15 meters, making it useful if you lost an item at home or nearby.

1. Once you've connected the SmartTag+ to the SmartThings app on your phone or tablet, open the app, and then tap the **Life** tab. Tap the **SmartThings Find** card.
2. Make sure you've selected your SmartTag+, and then tap **Search nearby**.
3. Wait a few seconds, and then tap **Find using camera**.  
**Note:** The Find using camera option may not appear if the signal is too weak.
4. You may need to grant permissions before opening the camera. Next, point your device around your current area.
5. If the signal is strong enough, you may see arrows on the screen pointing you in the right direction as you approach the SmartTag+.

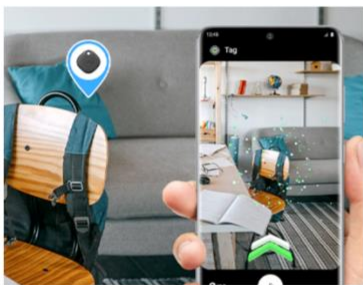

6. Tap the **music note** icon to make the SmartTag+ ring, so it's easier to find.
7. If you get close enough to the SmartTag+ and missing item, a popup message will appear, informing you that it's nearby.



See <https://www.samsung.com/us/support/answer/ANS00088244/>.

## FiRa Certified Devices

The FiRa Certified™ logo can now be proudly displayed on the following devices\*:

	Company Name	Device Name	Device Type	Certification	Date Certified
	NXP	Trimension SR150	Chipset	Base	October 27, 2021
	NXP	Trimension SR040	Chipset	Base	October 27, 2021
	Samsung	Galaxy S21 Ultra 5G	Smartphone	Base	October 27, 2021

\*Please note that this may not represent a full listing of FiRa Certified devices; some organizations may choose to not have their devices listed.

See <https://www.firaconsortium.org/certifications/certified-devices>.

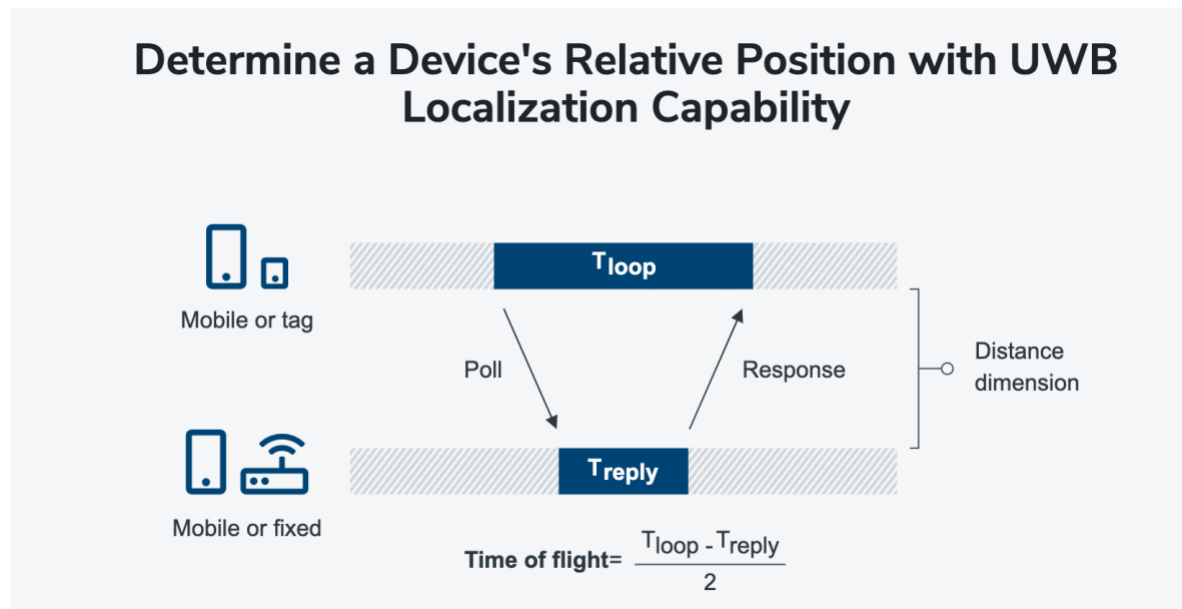

See [https://www.nxp.com/applications/enabling-technologies/connectivity/ultra-wideband-  
uwb:UWB](https://www.nxp.com/applications/enabling-technologies/connectivity/ultra-wideband-<br/>uwb:UWB).



**6.9.1.2.2 Single-sided two-way ranging (SS-TWR)**

SS-TWR involves a measurement of the round-trip delay of a single message from one device to another and a response sent back to the original device. The operation of SS-TWR is as shown in Figure 6-47a, where device A initiates the exchange and device B responds to complete the exchange and  $T_{prop}$  is the propagation time of the RMARKER between the devices.

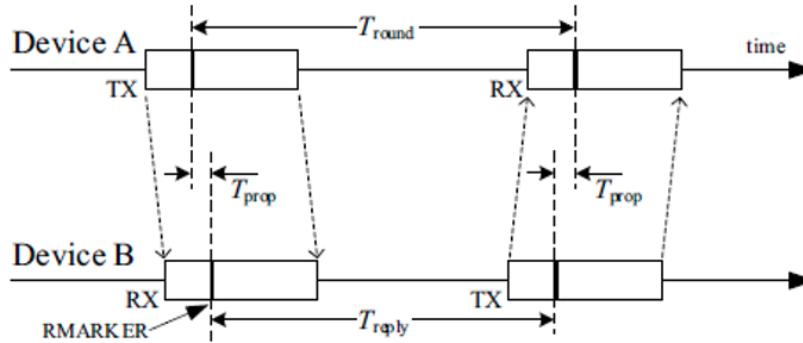

**Figure 6-47a—SS-TWR**

Each device precisely measures the transmission and reception times of the message frames, and so can calculate times  $T_{round}$  and  $T_{reply}$  by simple subtraction. Hence, the resultant TOF may be estimated as  $\hat{T}_{prop}$  by the equation:

$$\hat{T}_{prop} = \frac{1}{2}(T_{round} - T_{reply})$$

\* \* \*

When employing SS-TWR, for the TOF to be calculated at device A, device A needs the reply time  $T_{reply}$  employed by device B. When  $T_{reply}$  is determined by device B after its transmission, an additional message is necessary to bring this value to device A, as shown in Figure 6-48a and described in 6.9.6.3. When  $T_{reply}$  can be accurately predicted by device B before its transmission, the value can be embedded in the reply message itself, as shown in Figure 6-48b and described in 6.9.6.4. Alternatively, if device B has the ability to always reply with sufficiently accurate constant or pre-known reply time, it obviates the need for any transfer of  $T_{reply}$  as part of the ranging exchange, as described in 6.9.6.5.

See IEEE 802.15.4z-2020 - IEEE Standard for Low-Rate Wireless Networks—Amendment 1: Enhanced Ultra Wideband (UWB) Physical Layers (PHYs) and Associated Ranging Techniques at Section 6.9.1.2.2.

31. Claim 18 of the '779 Patent recites a “controller for” “estimating a range to the target wireless communications device based upon a plurality of determined propagation delays.”

The Accused Devices comprise a controller for estimating a range to the target wireless communications device based upon a plurality of determined propagation delays. For example, the Samsung S21 Ultra comprises a controller for estimating a range to the target wireless communications device (such as a Samsung Galaxy SmartTag+) based upon a plurality of determined propagation delays:

### SmartTag+ AR finding ▼

**Note:** The Samsung Galaxy SmartTag+ is compatible with Android OS 8.0 or higher. However, to use the AR finding feature, your Galaxy phone or tablet must support Android 11 or higher. The feature is currently available on Note 20 Ultra, S21+, S21 Ultra, and Z Fold 2. iOS devices and third-party Android devices are not supported.

The SmartTag+ is similar to the SmartTag, but it also offers augmented reality (AR) finding via Ultra-wideband technology. This feature uses your phone's camera to track the precise location of the SmartTag+ within 15 meters, making it useful if you lost an item at home or nearby.

1. Once you've connected the SmartTag+ to the SmartThings app on your phone or tablet, open the app, and then tap the **Life** tab. Tap the **SmartThings Find** card.
2. Make sure you've selected your SmartTag+, and then tap **Search nearby**.
3. Wait a few seconds, and then tap **Find using camera**.

**Note:** The Find using camera option may not appear if the signal is too weak.

4. You may need to grant permissions before opening the camera. Next, point your device around your current area.
5. If the signal is strong enough, you may see arrows on the screen pointing you in the right direction as you approach the SmartTag+.



6. Tap the **music note** icon to make the SmartTag+ ring, so it's easier to find.
7. If you get close enough to the SmartTag+ and missing item, a popup message will appear, informing you that it's nearby.

See <https://www.samsung.com/us/support/answer/ANS00088244/>.

## FiRa Certified Devices

The FiRa Certified™ logo can now be proudly displayed on the following devices\*:

	Company Name	Device Name	Device Type	Certification	Date Certified
	NXP	Trimension SR150	Chipset	Base	October 27, 2021
	NXP	Trimension SR040	Chipset	Base	October 27, 2021
	Samsung	Galaxy S21 Ultra 5G	Smartphone	Base	October 27, 2021

\*Please note that this may not represent a full listing of FiRa Certified devices; some organizations may choose to not have their devices listed.

See <https://www.firaconsortium.org/certifications/certified-devices>.

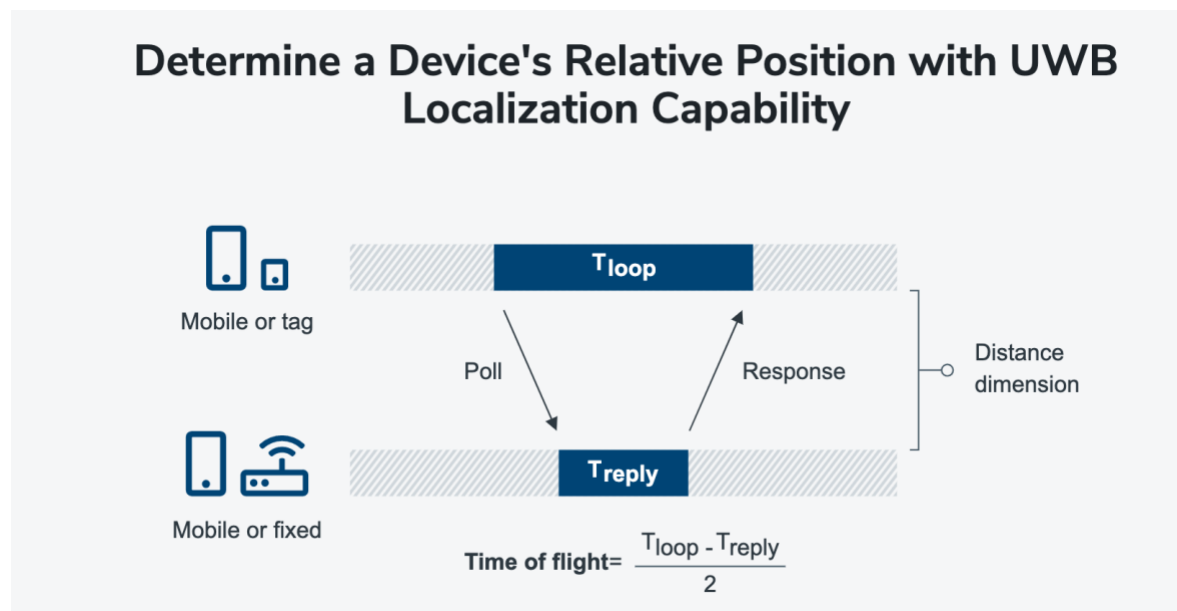

See <https://www.nxp.com/applications/enabling-technologies/connectivity/ultra-wideband-uw:UWB>.

### 6.9.1.1 Overview

Support for ranging is optional. A device that supports ranging is called a ranging-capable device (RDEV). An RDEV shall support the ranging counter described in 6.9.1.3 and the figure of merit (FoM) described in 6.9.1.7. An RDEV may support optional crystal characterization described in 6.9.1.6 and the optional dynamic preamble code and channel selection (DPS) described in “Applications of IEEE Std 802.15.4” [B3]. RDEVs produce ranging results, used by higher layers to compute the ranges between devices. These ranging results may include transmit and receive ranging counter values, ranging FoM, angle of arrival (AOA) information, ranging tracking interval, and ranging tracking offset values.

Ranging is an optional feature. This standard includes optional features to support relative positioning and localization. Accurate location may be achieved by a ranging-capable device (RDEV) using one of the ultra wideband (UWB) PHYs defined in this standard that provide the capability to accurately determine packet reception and transmission times. With accurate message timestamping, techniques such as two-way ranging (TWR) time of flight (TOF) can give very accurate estimates of relative separation distance between two devices. Similarly, an accurate location estimate for a mobile device can be determined, for example, when its distance from a number of fixed devices (of known location) is ascertained.

See IEEE 802.15.4z-2020 - IEEE Standard for Low-Rate Wireless Networks—Amendment 1: Enhanced Ultra Wideband (UWB) Physical Layers (PHYs) and Associated Ranging Techniques at Section 6.9.1.1.

32. Samsung also knowingly and intentionally induces infringement of one or more claims of the '779 Patent in violation of 35 U.S.C. § 271(b). As of at least the filing and service of this complaint, Samsung has knowledge of the '779 Patent and the infringing nature of the Accused Products. Despite this knowledge of the '779 Patent, Samsung continues to actively encourage and instruct its customers and end users (for example, through user manuals and online instruction materials on its website) to use the Accused Products in ways that directly infringe the '779 Patent, for example by utilizing the accused ultra-wideband functionality on the Accused Products in an infringing manner. See, e.g., [https://downloadcenter.samsung.com/content/PM/202101/20210129215516972/EB/SAM\\_G991\\_U\\_G996U\\_G998U\\_EN\\_FINAL\\_210122/start\\_here.html](https://downloadcenter.samsung.com/content/PM/202101/20210129215516972/EB/SAM_G991_U_G996U_G998U_EN_FINAL_210122/start_here.html) (Samsung Galaxy S21 5G Series User Manual); <https://www.samsung.com/us/support/answer/ANS00088244/> (Samsung Galaxy

SmartTag+ instructions); <https://insights.samsung.com/2021/07/16/how-to-use-samsung-galaxy-smarttag-technology-2/> Samsung Galaxy SmartTag+ instructions). Further, Samsung advertises to its customers and end users that the “AR Finder” mode on a Samsung handset utilizes the infringing ultra-wideband technology to locate a Samsung Galaxy SmartTag+. See <https://news.samsung.com/us/introducing-the-new-galaxy-smarttag-plus/>. Samsung provides these instructions and online materials knowing and intending (or with willful blindness to the fact) that its customers and end users will commit these infringing acts. Samsung also continues to make, use, offer for sale, sell, and/or import the Accused Products, despite its knowledge of the ’779 Patent, thereby specifically intending for and inducing its customers to infringe the ’779 Patent through the customers’ normal and customary use of the Accused Products.

33. Samsung has also infringed, and continues to infringe, one or more claims of the ’779 Patent by selling, offering for sale, or importing into the United States, the Accused Products, knowing that the Accused Products constitute a material part of the inventions claimed in the ’779 Patent, are especially made or adapted to infringe the ’779 Patent, and are not staple articles or commodities of commerce suitable for non-infringing use (as exemplified by the materials cited above). As of at least the filing and service of this complaint, Samsung has knowledge of the ’779 Patent and the infringing nature of the Accused Products. Samsung has been, and currently is, contributorily infringing the ’779 Patent in violation of 35 U.S.C. §§ 271(c) and (f).

34. By making, using, offering for sale, selling and/or importing into the United States the Accused Products, Samsung has injured Plaintiff and is liable for infringement of the ’779 Patent pursuant to 35 U.S.C. § 271.



35. As a result of Samsung's infringement of the '779 Patent, Plaintiff is entitled to monetary damages (past, present, and future) in an amount adequate to compensate for Samsung's infringement, but in no event less than a reasonable royalty for the use made of the invention by Samsung, together with interest and costs as fixed by the Court.

### **COUNT III**

#### **INFRINGEMENT OF U.S. PATENT NO. 7,321,777**

36. Plaintiff realleges and incorporates by reference the foregoing paragraphs as if fully set forth herein.

37. Samsung has been and is now directly infringing the '777 Patent, literally and/or under the doctrine of equivalents, in violation of 35 U.S.C. § 271(a), including by making, using, selling, and/or offering for sale in the United States or importing into the United States infringing products and systems, including at least the Accused Products identified above. The Accused Products satisfy all of the claim limitations of one or more claims of the '777 Patent, including but not limited to claim 12.

38. Claim 12 of the '777 Patent recites “[a] wireless device locator for locating a target wireless communications device.” To the extent the preamble is limiting, the Accused Products comprise of a wireless device locator for locating a target wireless communications device. For example, the accused Samsung Galaxy S21 Ultra supports ultra-wideband functionality for locating a target wireless communications device, such as the Samsung Galaxy SmartTag+:

Network & Connectivity	Galaxy S21 5G and S21+ 5G	Galaxy S21 Ultra 5G
	<b>5G</b> 5G Non-Standalone (NSA), Standalone (SA), Sub6 / mmWave	<b>5G</b> 5G Non-Standalone (NSA), Standalone (SA), Sub6 / mmWave
	<b>LTE</b> Enhanced 4x4 MIMO, Up to 7CA, LTE Cat.20 Up to 2.0Gbps Download / Up to 200Mbps Upload	<b>LTE</b> Enhanced 4x4 MIMO, Up to 7CA, LTE Cat.20 Up to 2.0Gbps Download / Up to 200Mbps Upload
	<b>Wi-Fi</b> Wi-Fi 802.11 a/b/g/n/ac/ax 2.4G+5GHz, HE80, MIMO, 1024-QAM Up to 1.2Gbps Download / Up to 1.2Gbps Upload	<b>Wi-Fi</b> Wi-Fi 802.11 a/b/g/n/ac/ax 2.4G+5GHz+6GHz, HE160, MIMO, 1024-QAM Up to 2.4Gbps Download / Up to 2.4Gbps Upload
	<b>Bluetooth</b> Bluetooth® v 5.0, USB type-C, NFC, Location (GPS, Galileo, Glonass, BeiDou)	<b>Bluetooth</b> Bluetooth® v 5.2, USB type-C, NFC, Location (GPS, Galileo, Glonass, BeiDou)
	<b>Ultra Wide Band</b>	<b>Ultra Wide Band</b>

See <https://www.samsung.com/global/galaxy/galaxy-s21-ultra-5g/specs/>.



**Locate your belongings visually with new AR Finder technology**

Because Galaxy SmartTag+ is both BLE- and UWB-enabled, you can now use AR technology to find your missing item[5]. The AR Finder guides you with an easy-to-follow interface on your UWB-equipped smartphone, such as Galaxy S21+ or S21 Ultra, which shows you how far away you are from your Galaxy SmartTag+ and points you in its direction. And once you're closer to the tag's location, you can choose to have it produce a loud ring so that even if it's slipped under the sofa, you'll have no trouble finding it.

See <https://news.samsung.com/us/introducing-the-new-galaxy-smarttag-plus/>.

39. Claim 12 of the '777 Patent recites that the wireless device locator comprises “at least one antenna and a transceiver connected thereto.” The Accused Products comprise at least one antenna and a transceiver connected thereto. For example, the Samsung S21 Ultra comprises at least one antenna and a transceiver:

Network & Connectivity	Galaxy S21 5G and S21+ 5G	Galaxy S21 Ultra 5G
	5G 5G Non-Standalone (NSA), Standalone (SA), Sub6 / mmWave	5G 5G Non-Standalone (NSA), Standalone (SA), Sub6 / mmWave
	LTE Enhanced 4x4 MIMO, Up to 7CA, LTE Cat.20 Up to 2.0Gbps Download / Up to 200Mbps Upload	LTE Enhanced 4x4 MIMO, Up to 7CA, LTE Cat.20 Up to 2.0Gbps Download / Up to 200Mbps Upload
	Wi-Fi Wi-Fi 802.11 a/b/g/n/ac/ax 2.4G+5GHz, HE80, MIMO, 1024-QAM Up to 1.2Gbps Download / Up to 1.2Gbps Upload	Wi-Fi Wi-Fi 802.11 a/b/g/n/ac/ax 2.4G+5GHz+6GHz, HE160, MIMO, 1024-QAM Up to 2.4Gbps Download / Up to 2.4Gbps Upload
	Bluetooth Bluetooth® v 5.0, USB type-C, NFC, Location (GPS, Galileo, Glonass, BeiDou)	Bluetooth Bluetooth® v 5.2, USB type-C, NFC, Location (GPS, Galileo, Glonass, BeiDou)
	Ultra Wide Band	Ultra Wide Band

See <https://www.samsung.com/global/galaxy/galaxy-s21-ultra-5g/specs/>.



## NXP's Trimension™ Ultra-Wideband Technology Helps Samsung Users Easily Find Their Misplaced Belongings

***NXP's UWB and Bluetooth® technologies work together to provide greater location accuracy for Samsung Galaxy SmartTag+***

**COMPUTEX, Taipei, Taiwan, June 2, 2021** – NXP Semiconductors announced that its Trimension Ultra-Wideband platform now offers fine ranging for new tagging use cases. UWB and Bluetooth® Low Energy solutions have been combined to deliver spatial awareness to the new Samsung Galaxy SmartTag+, providing an enhanced experience to the Samsung SmartThings Find service.



See <https://www.nxp.com/docs/en/supporting-information/NXPs-TrimensionTM-Ultra-Wideband-Technology-Helps-Samsung-Users-Easily-Find-Their-M.pdf>.

## FiRa Certified Devices

The FiRa Certified™ logo can now be proudly displayed on the following devices\*:

	Company Name	Device Name	Device Type	Certification	Date Certified
	NXP	Trimension SR150	Chipset	Base	October 27, 2021
	NXP	Trimension SR040	Chipset	Base	October 27, 2021
	Samsung	Galaxy S21 Ultra 5G	Smartphone	Base	October 27, 2021

\*Please note that this may not represent a full listing of FiRa Certified devices; some organizations may choose to not have their devices listed.

See <https://www.firaconsortium.org/certifications/certified-devices>.

40. Claim 12 of the '777 Patent recites “a controller for” “cooperating with said transceiver for transmitting a plurality of location finding signals to the target wireless communications device and receiving a respective reply signal therefrom for each of said location finding signals.” The Accused Products comprise a controller for cooperating with said transceiver for transmitting a plurality of location finding signals to the target wireless communications device and receiving a respective reply signal therefrom for each of said location finding signals. For example, the Samsung S21 Ultra comprises a controller that cooperates with a transceiver for transmitting a plurality of location finding signals to a target wireless communications device (such as the Samsung Galaxy SmartTag+) and receiving a respective reply signal therefrom for each of said location finding signals:

## SmartTag+ AR finding



**Note:** The Samsung Galaxy SmartTag+ is compatible with Android OS 8.0 or higher. However, to use the AR finding feature, your Galaxy phone or tablet must support Android 11 or higher. The feature is currently available on Note 20 Ultra, S21+, S21 Ultra, and Z Fold 2. iOS devices and third-party Android devices are not supported.

The SmartTag+ is similar to the SmartTag, but it also offers augmented reality (AR) finding via Ultra-wideband technology. This feature uses your phone's camera to track the precise location of the SmartTag+ within 15 meters, making it useful if you lost an item at home or nearby.

1. Once you've connected the SmartTag+ to the SmartThings app on your phone or tablet, open the app, and then tap the **Life** tab. Tap the **SmartThings Find** card.
2. Make sure you've selected your SmartTag+, and then tap **Search nearby**.
3. Wait a few seconds, and then tap **Find using camera**.  
**Note:** The Find using camera option may not appear if the signal is too weak.
4. You may need to grant permissions before opening the camera. Next, point your device around your current area.
5. If the signal is strong enough, you may see arrows on the screen pointing you in the right direction as you approach the SmartTag+.

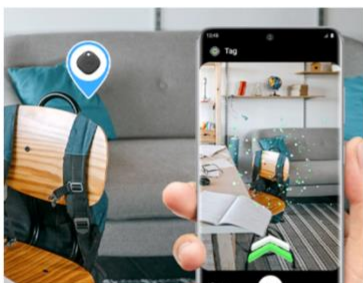

6. Tap the **music note** icon to make the SmartTag+ ring, so it's easier to find.
7. If you get close enough to the SmartTag+ and missing item, a popup message will appear, informing you that it's nearby.

See <https://www.samsung.com/us/support/answer/ANS00088244/>.

## FiRa Certified Devices

The FiRa Certified™ logo can now be proudly displayed on the following devices\*:

	Company Name	Device Name	Device Type	Certification	Date Certified
	NXP	Trimension SR150	Chipset	Base	October 27, 2021
	NXP	Trimension SR040	Chipset	Base	October 27, 2021
	Samsung	Galaxy S21 Ultra 5G	Smartphone	Base	October 27, 2021

\*Please note that this may not represent a full listing of FiRa Certified devices; some organizations may choose to not have their devices listed.

See <https://www.firaconsortium.org/certifications/certified-devices>.

## Determine a Device's Relative Position with UWB Localization Capability

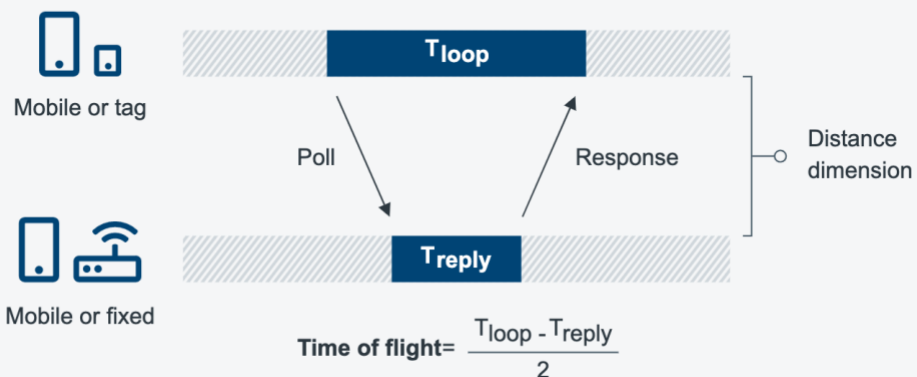

See <https://www.nxp.com/applications/enabling-technologies/connectivity/ultra-wideband-uwbi:UWB>.

### 6.9.1.2.2 Single-sided two-way ranging (SS-TWR)

SS-TWR involves a measurement of the round-trip delay of a single message from one device to another and a response sent back to the original device. The operation of SS-TWR is as shown in Figure 6-47a, where device A initiates the exchange and device B responds to complete the exchange and  $T_{\text{prop}}$  is the propagation time of the RMARKER between the devices.

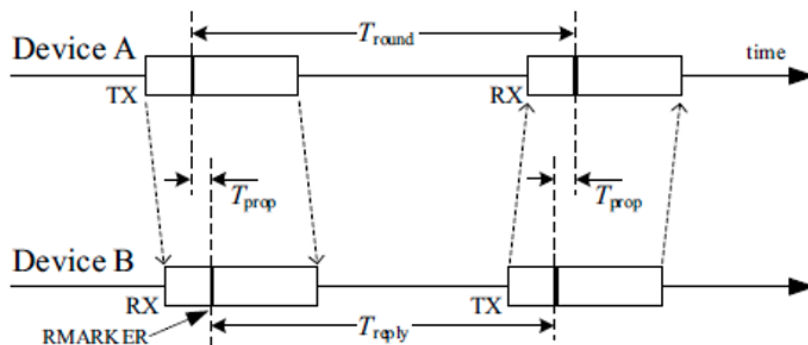

Figure 6-47a—SS-TWR

Each device precisely measures the transmission and reception times of the message frames, and so can calculate times  $T_{\text{round}}$  and  $T_{\text{reply}}$  by simple subtraction. Hence, the resultant TOF may be estimated as  $\hat{T}_{\text{prop}}$  by the equation:

$$\hat{T}_{\text{prop}} = \frac{1}{2}(T_{\text{round}} - T_{\text{reply}})$$

\* \* \*

When employing SS-TWR, for the TOF to be calculated at device A, device A needs the reply time  $T_{\text{reply}}$  employed by device B. When  $T_{\text{reply}}$  is determined by device B after its transmission, an additional message is necessary to bring this value to device A, as shown in Figure 6-48a and described in 6.9.6.3. When  $T_{\text{reply}}$  can be accurately predicted by device B before its transmission, the value can be embedded in the reply message itself, as shown in Figure 6-48b and described in 6.9.6.4. Alternatively, if device B has the ability to always reply with sufficiently accurate constant or pre-known reply time, it obviates the need for any transfer of  $T_{\text{reply}}$  as part of the ranging exchange, as described in 6.9.6.5.

See IEEE 802.15.4z-2020 - IEEE Standard for Low-Rate Wireless Networks—Amendment 1: Enhanced Ultra Wideband (UWB) Physical Layers (PHYs) and Associated Ranging Techniques at Section 6.9.1.2.2.

41. Claim 12 of the '777 Patent recites “a controller for” “determining a propagation delay associated with the transmission of each location finding signal and the respective reply

signal therefor based upon a known device latency of the target wireless communications device.”

The Accused Products comprise a controller for determining a propagation delay associated with the transmission of each location finding signal and the respective reply signal therefor based upon a known device latency of the target wireless communications device. For example, the Samsung S21 Ultra comprises a controller for determining a propagation delay associated with the transmission of each location finding signal and the respective reply signal therefor based upon a known device latency of the target wireless communications device (such as a Samsung Galaxy SmartTag+):

### SmartTag+ AR finding ▼

**Note:** The Samsung Galaxy SmartTag+ is compatible with Android OS 8.0 or higher. However, to use the AR finding feature, your Galaxy phone or tablet must support Android 11 or higher. The feature is currently available on Note 20 Ultra, S21+, S21 Ultra, and Z Fold 2. iOS devices and third-party Android devices are not supported.

The SmartTag+ is similar to the SmartTag, but it also offers augmented reality (AR) finding via Ultra-wideband technology. This feature uses your phone's camera to track the precise location of the SmartTag+ within 15 meters, making it useful if you lost an item at home or nearby.

1. Once you've connected the SmartTag+ to the SmartThings app on your phone or tablet, open the app, and then tap the **Life** tab. Tap the **SmartThings Find** card.
2. Make sure you've selected your SmartTag+, and then tap **Search nearby**.
3. Wait a few seconds, and then tap **Find using camera**.

**Note:** The Find using camera option may not appear if the signal is too weak.

4. You may need to grant permissions before opening the camera. Next, point your device around your current area.
5. If the signal is strong enough, you may see arrows on the screen pointing you in the right direction as you approach the SmartTag+.

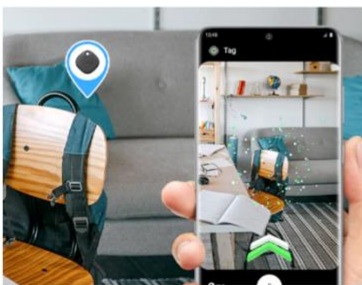

6. Tap the **music note** icon to make the SmartTag+ ring, so it's easier to find.
7. If you get close enough to the SmartTag+ and missing item, a popup message will appear, informing you that it's nearby.

See <https://www.samsung.com/us/support/answer/ANS00088244/>.

## FiRa Certified Devices

The FiRa Certified™ logo can now be proudly displayed on the following devices\*:

	Company Name	Device Name	Device Type	Certification	Date Certified
	NXP	Trimension SR150	Chipset	Base	October 27, 2021
	NXP	Trimension SR040	Chipset	Base	October 27, 2021
	Samsung	Galaxy S21 Ultra 5G	Smartphone	Base	October 27, 2021

\*Please note that this may not represent a full listing of FiRa Certified devices; some organizations may choose to not have their devices listed.

See <https://www.firaconsortium.org/certifications/certified-devices>.

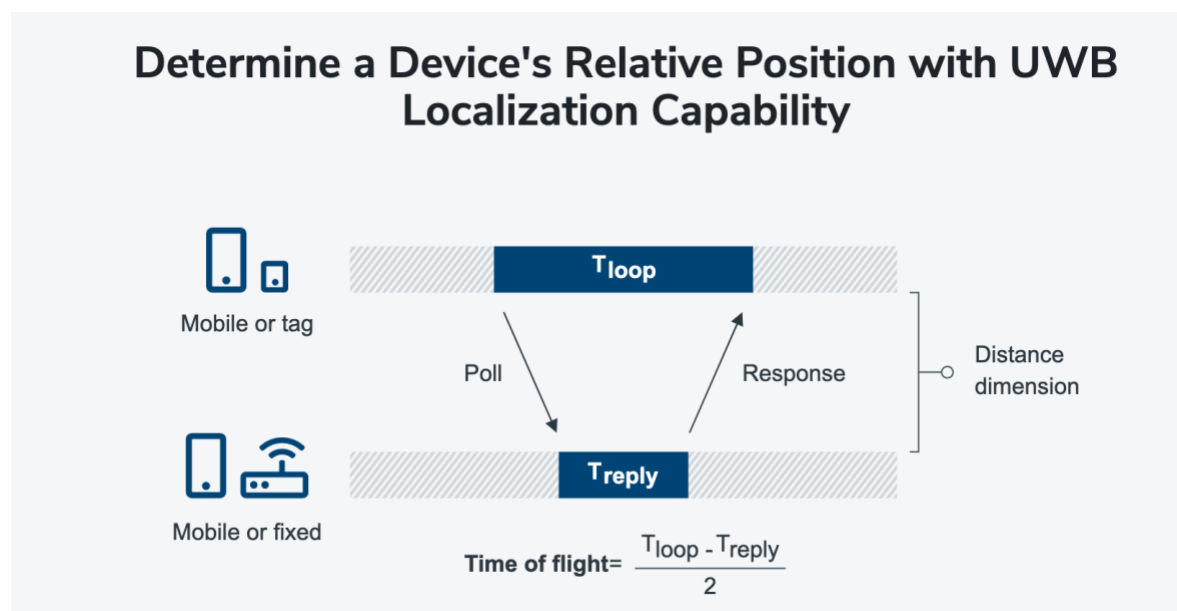

See <https://www.nxp.com/applications/enabling-technologies/connectivity/ultra-wideband-uw:UWB>.



**6.9.1.2.2 Single-sided two-way ranging (SS-TWR)**

SS-TWR involves a measurement of the round-trip delay of a single message from one device to another and a response sent back to the original device. The operation of SS-TWR is as shown in Figure 6-47a, where device A initiates the exchange and device B responds to complete the exchange and  $T_{prop}$  is the propagation time of the RMARKER between the devices.

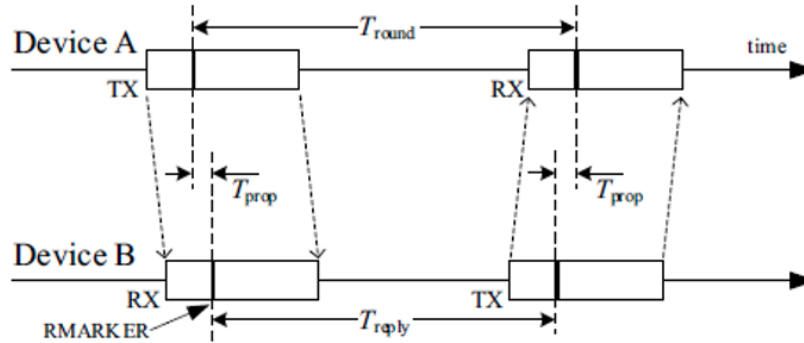

**Figure 6-47a—SS-TWR**

Each device precisely measures the transmission and reception times of the message frames, and so can calculate times  $T_{round}$  and  $T_{reply}$  by simple subtraction. Hence, the resultant TOF may be estimated as  $\hat{T}_{prop}$  by the equation:

$$\hat{T}_{prop} = \frac{1}{2}(T_{round} - T_{reply})$$

\* \* \*

When employing SS-TWR, for the TOF to be calculated at device A, device A needs the reply time  $T_{reply}$  employed by device B. When  $T_{reply}$  is determined by device B after its transmission, an additional message is necessary to bring this value to device A, as shown in Figure 6-48a and described in 6.9.6.3. When  $T_{reply}$  can be accurately predicted by device B before its transmission, the value can be embedded in the reply message itself, as shown in Figure 6-48b and described in 6.9.6.4. Alternatively, if device B has the ability to always reply with sufficiently accurate constant or pre-known reply time, it obviates the need for any transfer of  $T_{reply}$  as part of the ranging exchange, as described in 6.9.6.5.

See IEEE 802.15.4z-2020 - IEEE Standard for Low-Rate Wireless Networks—Amendment 1: Enhanced Ultra Wideband (UWB) Physical Layers (PHYs) and Associated Ranging Techniques at Section 6.9.1.2.2.

42. Claim 12 of the '777 Patent recites “a controller for” “estimating a range to the target wireless communications device based upon a plurality of determined propagation delays.”

The Accused Products comprise a controller for estimating a range to the target wireless communications device based upon a plurality of determined propagation delays. For example, the Samsung S21 Ultra comprises a controller for estimating a range to the target wireless communications device (such as a Samsung SmartTag+) based upon a plurality of determined propagation delays:

### SmartTag+ AR finding ▼

**Note:** The Samsung Galaxy SmartTag+ is compatible with Android OS 8.0 or higher. However, to use the AR finding feature, your Galaxy phone or tablet must support Android 11 or higher. The feature is currently available on Note 20 Ultra, S21+, S21 Ultra, and Z Fold 2. iOS devices and third-party Android devices are not supported.

The SmartTag+ is similar to the SmartTag, but it also offers augmented reality (AR) finding via Ultra-wideband technology. This feature uses your phone's camera to track the precise location of the SmartTag+ within 15 meters, making it useful if you lost an item at home or nearby.

1. Once you've connected the SmartTag+ to the SmartThings app on your phone or tablet, open the app, and then tap the **Life** tab. Tap the **SmartThings Find** card.
2. Make sure you've selected your SmartTag+, and then tap **Search nearby**.
3. Wait a few seconds, and then tap **Find using camera**.

**Note:** The Find using camera option may not appear if the signal is too weak.

4. You may need to grant permissions before opening the camera. Next, point your device around your current area.
5. If the signal is strong enough, you may see arrows on the screen pointing you in the right direction as you approach the SmartTag+.

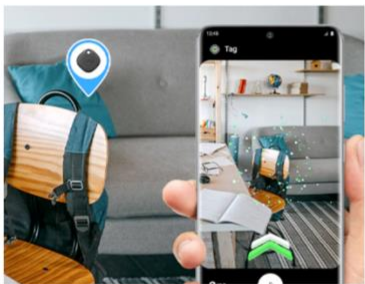

6. Tap the **music note** icon to make the SmartTag+ ring, so it's easier to find.
7. If you get close enough to the SmartTag+ and missing item, a popup message will appear, informing you that it's nearby.

See <https://www.samsung.com/us/support/answer/ANS00088244/>.

## FiRa Certified Devices

The FiRa Certified™ logo can now be proudly displayed on the following devices\*:

	Company Name	Device Name	Device Type	Certification	Date Certified
	NXP	Trimension SR150	Chipset	Base	October 27, 2021
	NXP	Trimension SR040	Chipset	Base	October 27, 2021
	Samsung	Galaxy S21 Ultra 5G	Smartphone	Base	October 27, 2021

\*Please note that this may not represent a full listing of FiRa Certified devices; some organizations may choose to not have their devices listed.

See <https://www.firaconsortium.org/certifications/certified-devices>.

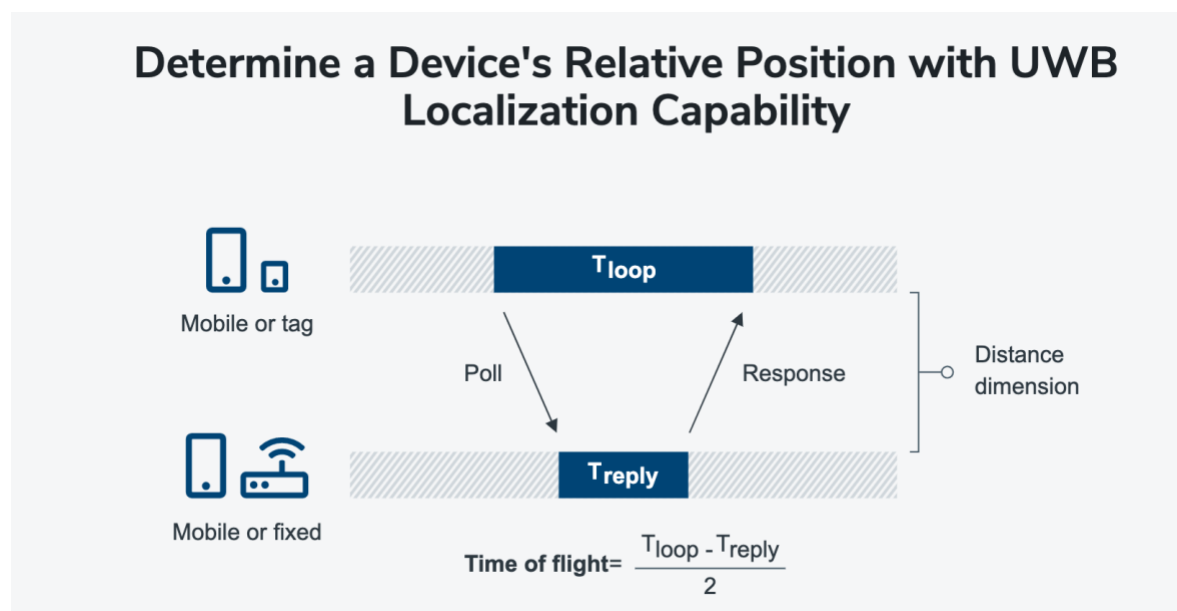

See <https://www.nxp.com/applications/enabling-technologies/connectivity/ultra-wideband-uw:UWB>.

### 6.9.1.1 Overview

Support for ranging is optional. A device that supports ranging is called a ranging-capable device (RDEV). An RDEV shall support the ranging counter described in 6.9.1.3 and the figure of merit (FoM) described in 6.9.1.7. An RDEV may support optional crystal characterization described in 6.9.1.6 and the optional dynamic preamble code and channel selection (DPS) described in “Applications of IEEE Std 802.15.4” [B3]. RDEVs produce ranging results, used by higher layers to compute the ranges between devices. These ranging results may include transmit and receive ranging counter values, ranging FoM, angle of arrival (AOA) information, ranging tracking interval, and ranging tracking offset values.

Ranging is an optional feature. This standard includes optional features to support relative positioning and localization. Accurate location may be achieved by a ranging-capable device (RDEV) using one of the ultra wideband (UWB) PHYs defined in this standard that provide the capability to accurately determine packet reception and transmission times. With accurate message timestamping, techniques such as two-way ranging (TWR) time of flight (TOF) can give very accurate estimates of relative separation distance between two devices. Similarly, an accurate location estimate for a mobile device can be determined, for example, when its distance from a number of fixed devices (of known location) is ascertained.

See IEEE 802.15.4z-2020 - IEEE Standard for Low-Rate Wireless Networks—Amendment 1: Enhanced Ultra Wideband (UWB) Physical Layers (PHYs) and Associated Ranging Techniques at Section 6.9.1.1.

43. Samsung also knowingly and intentionally induces infringement of one or more claims of the '777 Patent in violation of 35 U.S.C. § 271(b). As of at least the filing and service of this complaint, Samsung has knowledge of the '777 Patent and the infringing nature of the Accused Products. Despite this knowledge of the '777 Patent, Samsung continues to actively encourage and instruct its customers and end users (for example, through user manuals and online instruction materials on its website) to use the Accused Products in ways that directly infringe the '777 Patent, for example by utilizing the accused ultra-wideband functionality on the Accused Products in an infringing manner. See, e.g., [https://downloadcenter.samsung.com/content/PM/202101/20210129215516972/EB/SAM\\_G991U\\_G996U\\_G998U\\_EN\\_FINAL\\_210122/start\\_here.html](https://downloadcenter.samsung.com/content/PM/202101/20210129215516972/EB/SAM_G991U_G996U_G998U_EN_FINAL_210122/start_here.html) (Samsung Galaxy S21 5G Series User Manual); <https://www.samsung.com/us/support/answer/ANS00088244/> (Samsung Galaxy

SmartTag+ instructions); <https://insights.samsung.com/2021/07/16/how-to-use-samsung-galaxy-smarttag-technology-2/> Samsung Galaxy SmartTag+ instructions). Further, Samsung advertises to its customers and end users that the “AR Finder” mode on a Samsung handset utilizes the infringing ultra-wideband technology to locate a Samsung Galaxy SmartTag+. *See* <https://news.samsung.com/us/introducing-the-new-galaxy-smarttag-plus/>. Samsung provides these instructions and online materials knowing and intending (or with willful blindness to the fact) that its customers and end users will commit these infringing acts. Samsung also continues to make, use, offer for sale, sell, and/or import the Accused Products, despite its knowledge of the ’777 Patent, thereby specifically intending for and inducing its customers to infringe the ’777 Patent through the customers’ normal and customary use of the Accused Products.

44. Samsung has also infringed, and continues to infringe, one or more claims of the ’777 Patent by selling, offering for sale, or importing into the United States, the Accused Products, knowing that the Accused Products constitute a material part of the inventions claimed in the ’777 Patent, are especially made or adapted to infringe the ’777 Patent, and are not staple articles or commodities of commerce suitable for non-infringing use (as exemplified by the materials cited above). As of at least the filing and service of this complaint, Samsung has knowledge of the ’777 Patent and the infringing nature of the Accused Products. Samsung has been, and currently is, contributorily infringing the ’777 Patent in violation of 35 U.S.C. §§ 271(c) and (f).

45. By making, using, offering for sale, selling and/or importing into the United States the Accused Products, Samsung has injured Plaintiff and is liable for infringement of the ’777 Patent pursuant to 35 U.S.C. § 271.



46. As a result of Samsung's infringement of the '777 Patent, Plaintiff is entitled to monetary damages (past, present, and future) in an amount adequate to compensate for Samsung's infringement, but in no event less than a reasonable royalty for the use made of the invention by Samsung, together with interest and costs as fixed by the Court.

**PRAYER FOR RELIEF**

WHEREFORE, Plaintiff respectfully requests that this Court enter:

a. A judgment in favor of Plaintiff that Samsung has infringed, either literally and/or under the doctrine of equivalents, the '780, '779, and '777 Patents;

b. A judgment and order requiring Samsung to pay Plaintiff its damages (past, present, and future), costs, expenses, and pre-judgment and post-judgment interest for Samsung's infringement of the '780, '779, and '777 Patents;

c. A judgment and order requiring Samsung to pay Plaintiff compulsory ongoing licensing fees, as determined by the Court in equity.

d. A judgment and order requiring Samsung to provide an accounting and to pay supplemental damages to Plaintiff, including without limitation, pre-judgment and post-judgment interest and compensation for infringing products released after the filing of this case that are not colorably different from the accused products;

e. A judgment and order finding that this is an exceptional case within the meaning of 35 U.S.C. § 285 and awarding to Plaintiff its reasonable attorneys' fees against Samsung; and

f. Any and all other relief as the Court may deem appropriate and just under the circumstances.



**DEMAND FOR JURY TRIAL**

Plaintiff, under Rule 38 of the Federal Rules of Civil Procedure, requests a trial by jury of any issues so triable by right.

Dated: December 30, 2021

Respectfully submitted,

/s/Brett E. Cooper

Brett E. Cooper (NY SBN 4011011) (Lead Counsel)

[bcooper@raklaw.com](mailto:bcooper@raklaw.com)

Reza Mirzaie (CA SBN 246953)

[rmirzaie@raklaw.com](mailto:rmirzaie@raklaw.com)

Marc A. Fenster (CA SBN 181067)

[mfenster@raklaw.com](mailto:mfenster@raklaw.com)

Seth Hasenour (TX SBN 24059910)

[shasenour@raklaw.com](mailto:shasenour@raklaw.com)

Drew B. Hollander (NY SBN 5378096)

[dhollander@raklaw.com](mailto:dhollander@raklaw.com)

RUSS AUGUST & KABAT  
12424 Wilshire Blvd. 12th Floor  
Los Angeles, CA 90025  
Phone: (310) 826-7474  
Facsimile: (310) 826-6991

*Attorneys for Plaintiff Speir Technologies Limited*