

**IN THE UNITED STATES DISTRICT COURT
FOR THE WESTERN DISTRICT OF TEXAS
WACO DIVISION**

AMERICAN PATENTS LLC,

Plaintiff,

v.

QUALCOMM INC. AND QUALCOMM
TECHNOLOGIES, INC.,

Defendants.

CIVIL ACTION NO. 6:22-cv-774

ORIGINAL COMPLAINT FOR
PATENT INFRINGEMENT

JURY TRIAL DEMANDED

ORIGINAL COMPLAINT FOR PATENT INFRINGEMENT

Plaintiff American Patents LLC (“American Patents” or “Plaintiff”) files this original complaint against Defendants Qualcomm Inc. and Qualcomm Technologies, Inc. (“Defendants” or “Qualcomm”), alleging, based on its own knowledge as to itself and its own actions and based on information and belief as to all other matters, as follows:

PARTIES

1. American Patents is a limited liability company formed under the laws of the State of Texas, with its principal place of business at 2325 Oak Alley, Tyler, Texas, 75703.

2. Qualcomm Inc. is a company organized and existing under the laws of Delaware. Qualcomm Inc. may be served with process through its registered agent, Prentice-Hall Corporation System Inc., at 211 E. 7th Street Suite 620, Austin, Texas 78701.

3. Qualcomm Technologies, Inc. is a company organized and existing under the laws of Delaware. Qualcomm Technologies, Inc. may be served with process through its registered agent, Corporation Service Company d/b/a CSC-Lawyers Incorporating Service, at 211 E. 7th Street Suite 620, Austin, Texas 78701.

4. Qualcomm Technologies, Inc. is a wholly owned subsidiary of Qualcomm Inc. Qualcomm Technologies, Inc. operates, along with its subsidiaries, substantially all of Qualcomm’s engineering research and development functions and substantially all of its products and services businesses.¹

5. The Defendants identified in paragraphs 2-4 above (collectively, “Qualcomm”) are companies which together comprise one of the world’s largest manufacturers of integrated circuits for communications, including products under the Qualcomm brand. Qualcomm explains that it is a “global leader in the development and commercialization of foundational technologies for the wireless industry” and that its “technologies and products are used in mobile devices and other wireless products, and are sold across industries and applications beyond mobile handsets, including automotive and the internet of things (IoT) (which includes the industries and applications of consumer, industrial and edge networking), among others.”²

6. The Qualcomm Defendants named above and their affiliates are part of the same corporate structure and distribution chain for the making, importing, offering to sell, selling, and/or using of the accused devices in the United States, including in the State of Texas generally and this judicial district in particular. Qualcomm’s website states, for example, that “[r]eferences to ‘Qualcomm’ may mean Qualcomm Incorporated, or subsidiaries or business units within the Qualcomm corporate structure, as applicable.”³

¹ See Qualcomm Inc. Annual Report – Form 10-K, at 7 (Nov. 3, 2021), <https://investor.qualcomm.com/financial-information/sec-filings/content/0001728949-21-000076/0001728949-21-000076.pdf>. See also www.qualcomm.com.

² See Qualcomm Inc. Annual Report – Form 10-K, at 16 (Nov. 3, 2021), <https://investor.qualcomm.com/financial-information/sec-filings/content/0001728949-21-000076/0001728949-21-000076.pdf>.

³ See www.qualcomm.com.

7. The Qualcomm Defendants named above and their affiliates share the same management, common ownership, advertising platforms, facilities, distribution chains and platforms, and accused product lines and products involving related technologies.

8. The Qualcomm Defendants named above and their regularly contract with customers regarding products made for or on behalf of those customers.

9. Thus, the Qualcomm Defendants named above and their affiliates operate as a unitary business venture and are jointly and severally liable for the acts of patent infringement alleged herein.

JURISDICTION AND VENUE

10. This is an action for infringement of United States patents arising under 35 U.S.C. §§ 271, 281, and 284–85, among others. This Court has subject matter jurisdiction of the action under 28 U.S.C. § 1331 and § 1338(a).

11. This Court has personal jurisdiction over Qualcomm pursuant to due process and/or the Texas Long Arm Statute because, *inter alia*, (i) Qualcomm has done and continues to do business in Texas; (ii) Qualcomm has committed and continues to commit acts of patent infringement in the State of Texas, including making, using, offering to sell, and/or selling accused products in Texas, and/or importing accused products into Texas, including by Internet sales and sales via retail and wholesale stores, inducing others to commit acts of patent infringement in Texas, and/or committing a least a portion of any other infringements alleged herein; and (iii) Qualcomm is registered to do business in Texas.

12. Venue is proper in this district as to Qualcomm pursuant to 28 U.S.C. § 1400(b). Venue is further proper because Qualcomm has committed and continues to commit acts of patent infringement in this district, including making, using, offering to sell, and/or selling

accused products in this district, and/or importing accused products into this district, including by Internet sales and sales via retail and wholesale stores, inducing others to commit acts of patent infringement in Texas, and/or committing at least a portion of any other infringements alleged herein in this district. Qualcomm has regular and established places of business in this district, including at least at 9600 N. Mopac Expressway, Suite 900, Stonebridge Plaza II, Austin, Texas 78759, as shown in the following screenshots:



(Source: screenshot from Google Maps Street View)

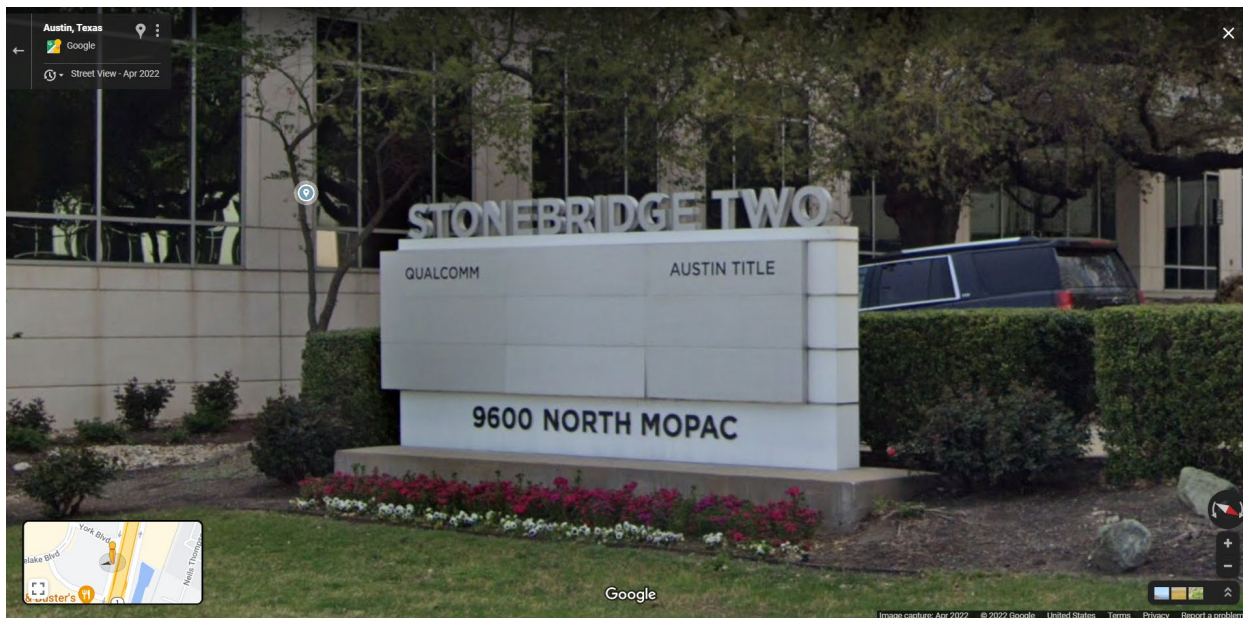

(Source: screenshot from Google Maps Street View)

BACKGROUND

13. The patents-in-suit generally pertain to communications networks and other technology used in “smart” devices such as smartphones, smart TVs, and smart appliances. The technology disclosed by the patents was developed by personnel at Georgia Institute of Technology (“Georgia Tech”).

14. Georgia Tech is a leading public research university located in Atlanta, Georgia. Founded in 1885, Georgia Tech is often ranked as one of the top ten public universities in the United States. The patents from Georgia Tech (“the Mody patents”) were developed by a professor and a graduate student in Georgia Tech’s Electrical and Computer Engineering department. The undergraduate and graduate programs of this department are often ranked in the top five of their respective categories.

15. The Mody patents are related to Multi-Input, Multi-Output (MIMO) technology. The inventors of the Mody patents were at the forefront of MIMO, developing, disclosing, and patenting a solution for achieving both time and frequency synchronization in MIMO systems.

The Mody patents (or the applications leading to them) have been cited during patent prosecution hundreds of times, by numerous leading companies in the computing and communications industries, including AMD, Alcatel Lucent, Altair, AT&T, Atheros, Blackberry, Broadcom, Comcast, Ericsson, Facebook, HP, Hitachi, Huawei, Infineon, Intel, Interdigital, IBM, Kyocera, Marvell, Matsushita, Mediatek, Motorola, NEC, Nokia, Nortel Networks, NXP, Panasonic, Philips, Qualcomm, Realtek, Samsung, Sanyo, Sharp, Sony, STMicroelectronics, Texas Instruments, and Toshiba.

COUNT I

INFRINGEMENT OF U.S. PATENT NO. 7,088,782

16. On August 8, 2006, United States Patent No. 7,088,782 (“the ‘782 Patent”) was duly and legally issued by the United States Patent and Trademark Office for an invention entitled “Time And Frequency Synchronization In Multi-Input, Multi-Output (MIMO) Systems.”

17. American Patents is the owner of the ‘782 Patent, with all substantive rights in and to that patent, including the sole and exclusive right to prosecute this action and enforce the ‘782 Patent against infringers, and to collect damages for all relevant times.

18. Qualcomm used products and/or systems including, for example, its Qualcomm FastConnect 7800 (with 4x4 MIMO), Qualcomm Snapdragon 888 5G Mobile Platform (with 2x2 MIMO), and Qualcomm QCA9379 (with 2x2 MIMO) families of products that include 802.11n and above and/or LTE capabilities (“accused products”):

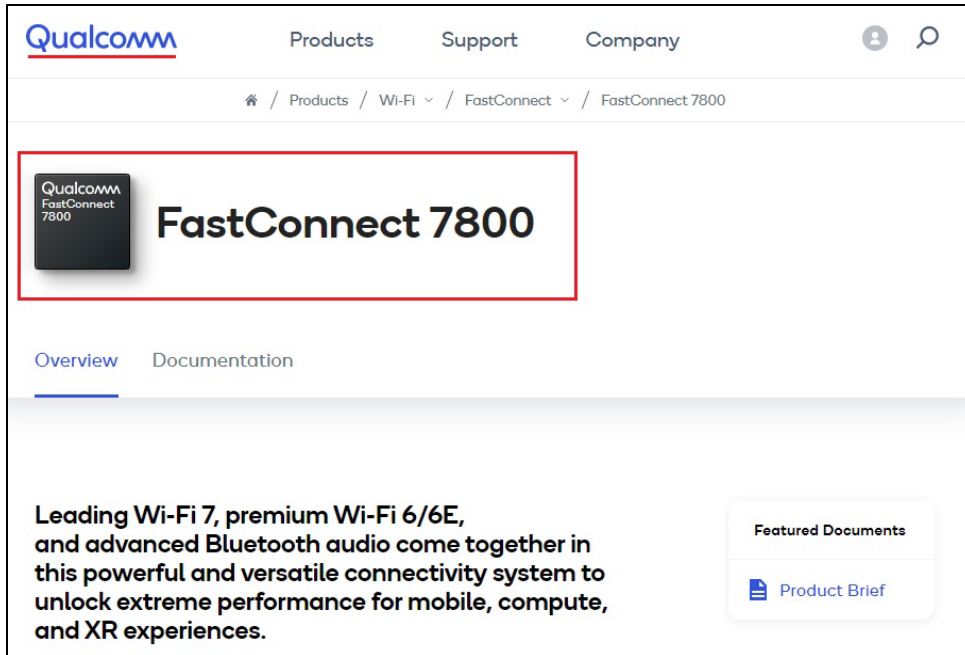

(Source : <https://www.qualcomm.com/products/fastconnect-7800>)

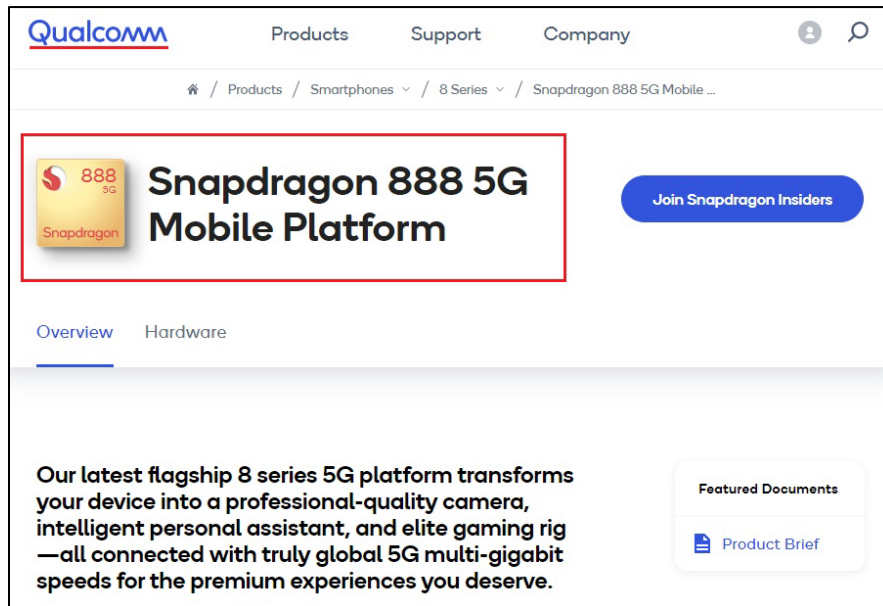

(Source : <https://www.qualcomm.com/products/snapdragon-888-5g-mobile-platform>)

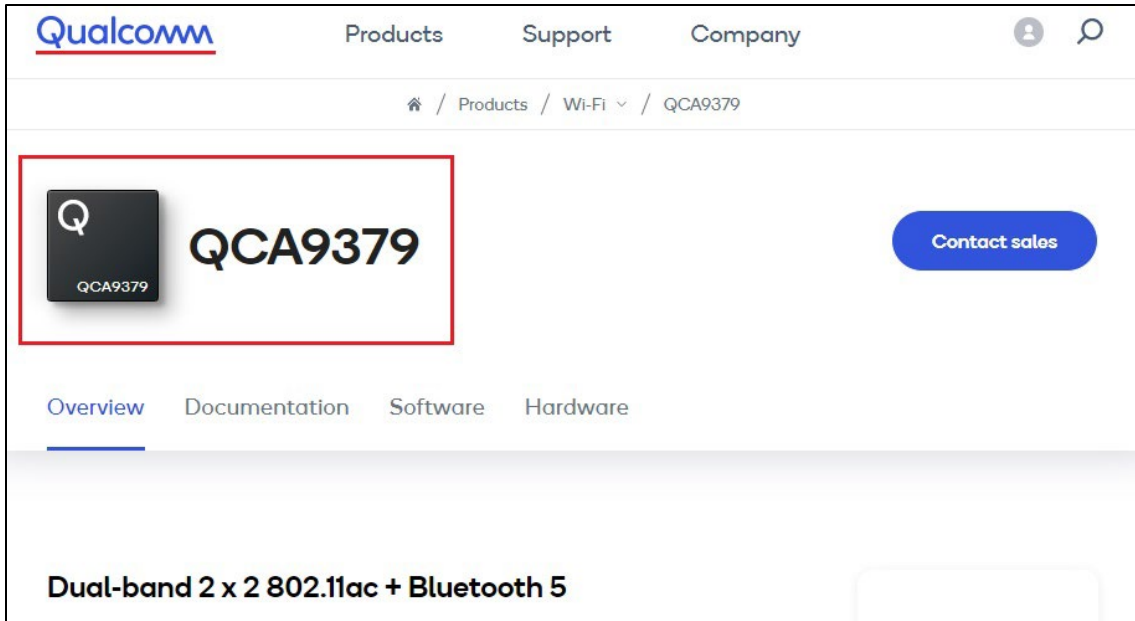

(Source : <https://www.qualcomm.com/products/technology/wi-fi/qca9379>)

Specifications	
Process Technology	14nm
<u>Wi-Fi Standards</u>	<u>Wi-Fi 7, Wi-Fi 6E, Wi-Fi 6 (802.11ax), 802.11ac wave 2, 802.11a/b/g, 802.11n</u>
Wi-Fi Spectral Bands	2.4GHz, 5GHz, 6GHz
Peak Speed	5.8 Gbps*
<u>Wi-Fi Features</u>	<u>4-Stream Dual Band Simultaneous in the High Bands, 4K QAM, Multi-Link Operation (MLO), 320MHz (single channel, or 160 + 160), 8x8 Sounding, MU-MIMO (Uplink and Downlink), OFDMA (Uplink and Downlink), Target Wake Time (TWT), Passpoint, Wi-Fi Aware R3, Wi-Fi Location, Wi-Fi Optimized Connectivity, Wi-Fi QoS Management, TDLS, Miracast, Voice-Enterprise</u>

(Source : <https://www.qualcomm.com/media/documents/files/mwc-2022-qualcomm-fastconnect-7800-product-brief.pdf>)

Wi-Fi & Bluetooth

- FastConnect 6900 System
 - Wi-Fi Standards: Wi-Fi 6E, Wi-Fi 6 (802.11ax), Wi-Fi 5 (802.11ac), 802.11a/b/a/n
 - Wi-Fi Spectral Bands: 2.4 GHz, 5 GHz, 6 GHz
 - Peak speed: 3.6 Gbps
 - Channel Utilization: 20/40/80/160 MHz
 - 8-stream sounding (for 8x8 MU-MIMO)
 - MIMO Configuration: 2x2 (2-stream)
 - MU-MIMO (Uplink & Downlink)
 - 4K QAM
 - OFDMA (Uplink & Downlink)
 - Dual-band simultaneous (2x2 + 2x2)
 - Wi-Fi Security: WPA3-Enterprise, WPA3-Enhanced Open, WPA3 Easy Connect, WPA3-Personal

(Source :

https://www.qualcomm.com/system/files/document/files/prod_brief_qcom_sd888_5g_1_0.pdf)

Wi-Fi	Standards: 802.11ac Wave 2, 802.11a/b/g, 802.11n
	Wi-Fi Spectral Bands: 2.4 GHz, 5 GHz
	Peak Speed: 620 Mbps
	Channel Utilization: 20/40/80 MHz
	MIMO Configuration: 2x2 (2-stream)
	Wi-Fi Features: MU-MIMO, TxBF

(Source : <https://www.qualcomm.com/products/technology/wi-fi/qca9379>)

19. By doing so, Qualcomm has directly infringed (literally and/or under the doctrine of equivalents) at least Claim 30 of the ‘782 Patent. Qualcomm’s infringement in this regard is ongoing.

20. Qualcomm has infringed the ‘782 Patent by using the accused products and thereby practicing a method for synchronizing a Multi-Input Multi-Output (MIMO) Orthogonal Frequency Division Multiplexing (OFDM) system in time and frequency domains. For example, the accused products support IEEE 802.11 n/ac standards and MIMO technology. According to the IEEE 802.11n standard, the PLCP Protocol Data Unit (PPDU) has training fields and signaling fields for helping in synchronizing the communication system.

Specifications	
Process Technology	14nm
<u>Wi-Fi Standards</u>	<u>Wi-Fi 7, Wi-Fi 6E, Wi-Fi 6 (802.11ax), 802.11ac wave 2, 802.11a/b/g, 802.11n</u>
Wi-Fi Spectral Bands	2.4GHz, 5GHz, 6GHz
Peak Speed	5.8 Gbps*
<u>Wi-Fi Features</u>	<u>4-Stream Dual Band Simultaneous in the High Bands,</u> 4K QAM, Multi-Link Operation (MLO), 320MHz (single channel, or 160 + 160), 8x8 Sounding, <u>MU-MIMO (Uplink and Downlink),</u> OFDMA (Uplink and Downlink), Target Wake Time (TWT), Passpoint, Wi-Fi Aware R3, Wi-Fi Location, Wi-Fi Optimized Connectivity, Wi-Fi QoS Management, TDLS, Miracast, Voice-Enterprise

(Source : <https://www.qualcomm.com/media/documents/files/mwc-2022-qualcomm-fastconnect-7800-product-brief.pdf>)

Wi-Fi & Bluetooth

- FastConnect 6900 System
 - Wi-Fi Standards: Wi-Fi 6E, Wi-Fi 6 (802.11ax), Wi-Fi 5 (802.11ac), 802.11a/b/g/n
 - Wi-Fi Spectral Bands: 2.4 GHz, 5 GHz, 6 GHz
 - Peak speed: 3.6 Gbps
 - Channel Utilization: 20/40/80/160 MHz
 - 8-stream sounding (for 8x8 MU-MIMO)
 - MIMO Configuration: 2x2 (2-stream)
 - MU-MIMO (Uplink & Downlink)
 - 4K QAM
 - OFDMA (Uplink & Downlink)
 - Dual-band simultaneous (2x2 + 2x2)
 - Wi-Fi Security: WPA3-Enterprise, WPA3-Enhanced Open, WPA3 Easy Connect, WPA3-Personal

(Source :

https://www.qualcomm.com/system/files/document/files/prod_brief_qcom_sd888_5g_1_0.pdf)

Wi-Fi	Standards: 802.11ac Wave 2, 802.11a/b/g, 802.11n
	Wi-Fi Spectral Bands: 2.4 GHz, 5 GHz
	Peak Speed: 620 Mbps
	Channel Utilization: 20/40/80 MHz
	MIMO Configuration: 2x2 (2-stream)
	Wi-Fi Features: MU-MIMO, TxBF

(Source : <https://www.qualcomm.com/products/technology/wi-fi/qca9379>)

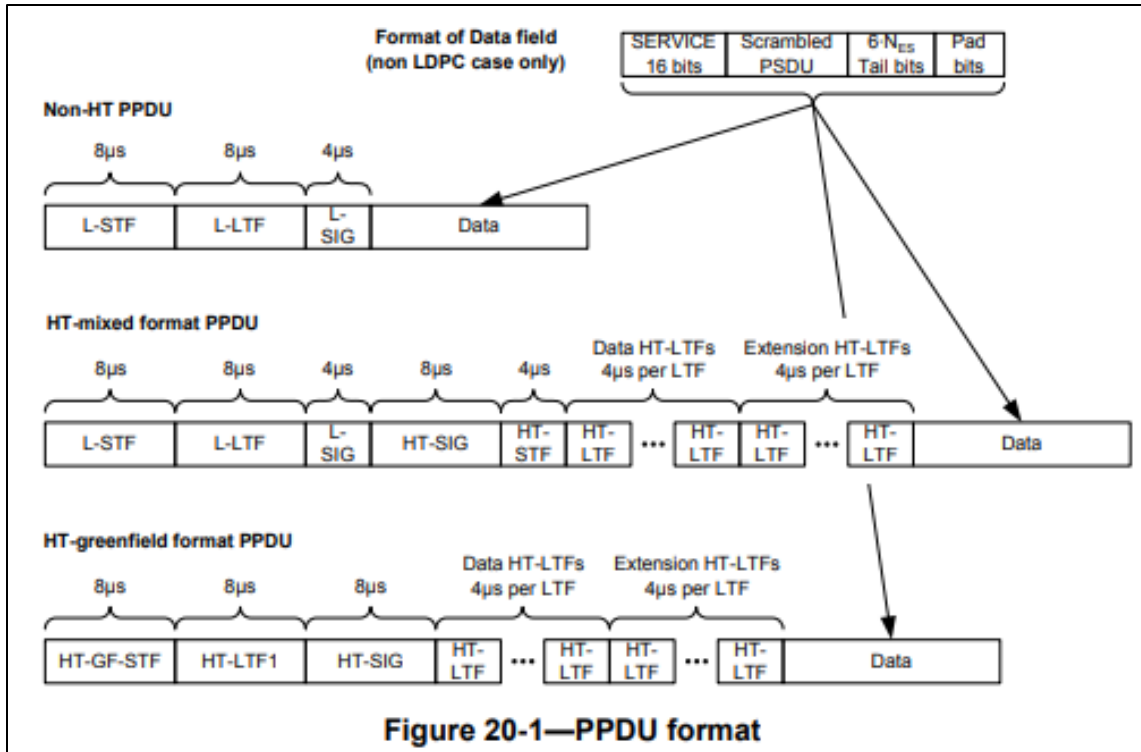

(Source: <https://web.archive.org/web/20190220214328/http://luci.subsignal.org/~jow/802.11n-2009.pdf>)

Table 20-4—Elements of the HT PLCP packet

Element	Description
L-STF	Non-HT Short Training field
L-LTF	Non-HT Long Training field
L-SIG	Non-HT SIGNAL field
HT-SIG	HT SIGNAL field
HT-STF	HT Short Training field
HT-GF-STF	HT-Greenfield Short Training field
HT-LTF1	First HT Long Training field (Data)
HT-LTFs	Additional HT Long Training fields (Data and Extension)
Data	The Data field includes the PSDU

(Source: <https://web.archive.org/web/20190220214328/http://luci.subsignal.org/~jow/802.11n-2009.pdf>)

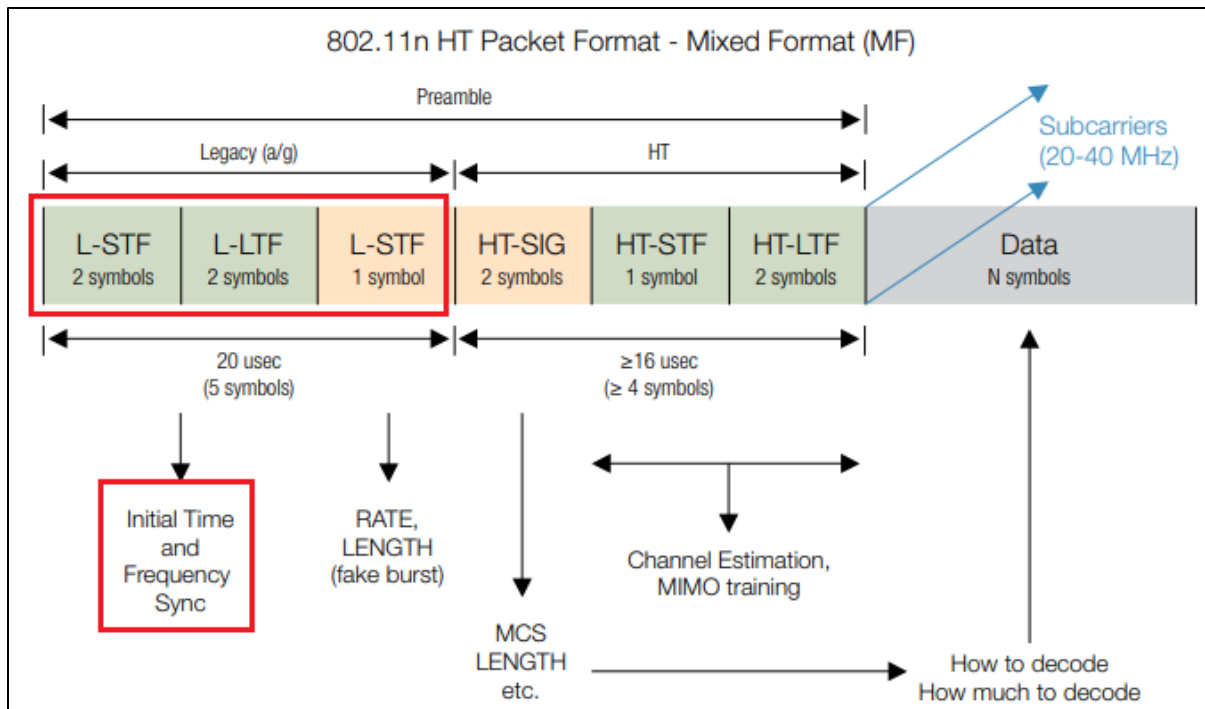

(Source: https://www.cnrood.com/en/media/solutions/Wi-Fi_Overview_of_the_802.11_Physical_Layer.pdf)

21. The methods practiced by Qualcomm's use of the accused products include producing a frame of data comprising a training symbol that includes a synchronization component that aids in synchronization, a plurality of data symbols, and a plurality of cyclic prefixes. For example, as part of the 802.11n standard, three preamble formats are defined for frames: non-HT, HT-mixed format and HT-greenfield format. The non-HT, HT-mixed, and HT-greenfield format preambles consist of training symbols, data symbols and guard intervals/cyclic prefixes, and the training symbols (L-STF, L-LTF, and other LTF and STF fields) are and have been used for frame synchronization. According to the IEEE 802.11n standard, all Protocol Data Unit (PPDU) frame formats have training fields and signaling fields which would help in synchronizing the communication system. Alternatively, on request from accused products, an 802.11 n/ac compliant WiFi access point can act as a transmitter and perform the step of

producing a frame of data comprising a training symbol that includes a synchronization component that aids in synchronization, a plurality of data symbols, and a plurality of cyclic prefixes.

Two preamble formats are defined. For HT-mixed format operation, the preamble has a non-HT portion and an HT portion. The non-HT portion of the HT-mixed format preamble enables detection of the PPDU and acquisition of carrier frequency and timing by both HT STAs and STAs that are compliant with Clause 17 and/or Clause 19. The non-HT portion of the HT-mixed format preamble also consists of the SIGNAL field defined in Clause 17 and is thus decodable by STAs compliant with Clause 17 and Clause 19 as well as HT STAs.

The HT portion of the HT-mixed format preamble enables estimation of the MIMO channel to support demodulation of the HT data by HT STAs. The HT portion of the HT-mixed format preamble also includes the HT-SIG field, which supports HT operation. The SERVICE field is prepended to the PSDU.

(Source: <https://web.archive.org/web/20190220214328/http://luci.subsignal.org/~jow/802.11n-2009.pdf>)

- a) Determine the number of transmit chains, N_{TX} , from the N_TX field of the TXVECTOR. Produce the PLCP preamble training fields for each of the N_{TX} transmit chains based on the FORMAT, NUM_EXTEN_SS, CH_BANDWIDTH, and MCS parameters of the TXVECTOR. The format and relative placement of the PLCP preamble training fields vary depending on the frame format being used, as indicated by these parameters. Apply cyclic shifts. Determine spatial mapping to be used for HT-STF and HT-LTFs in HT-mixed format frame and HT-GF-STF and HT-LTFs in HT-greenfield format frame from the EXPANSION_MAT parameter of the TXVECTOR. Refer to 20.3.9 for details.
- b) Construct the PLCP preamble SIGNAL fields from the appropriate fields of the TXVECTOR by adding tail bits, applying convolutional coding, formatting into one or more OFDM symbols, applying cyclic shifts, applying spatial processing, calculating an inverse Fourier transform for each OFDM symbol and transmit chain, and prepending a cyclic prefix or GI to each OFDM symbol in each transmit chain. The number and placement of the PLCP preamble SIGNAL fields depend on the frame format being used. Refer to 20.3.9.3.5, 20.3.9.4.3, and 20.3.9.5.3.
- c) Concatenate the PLCP preamble training and SIGNAL fields for each transmit chain one field after another, in the appropriate order, as described in 20.3.2 and 20.3.7.

(Source: <https://web.archive.org/web/20190220214328/http://luci.subsignal.org/~jow/802.11n-2009.pdf>)

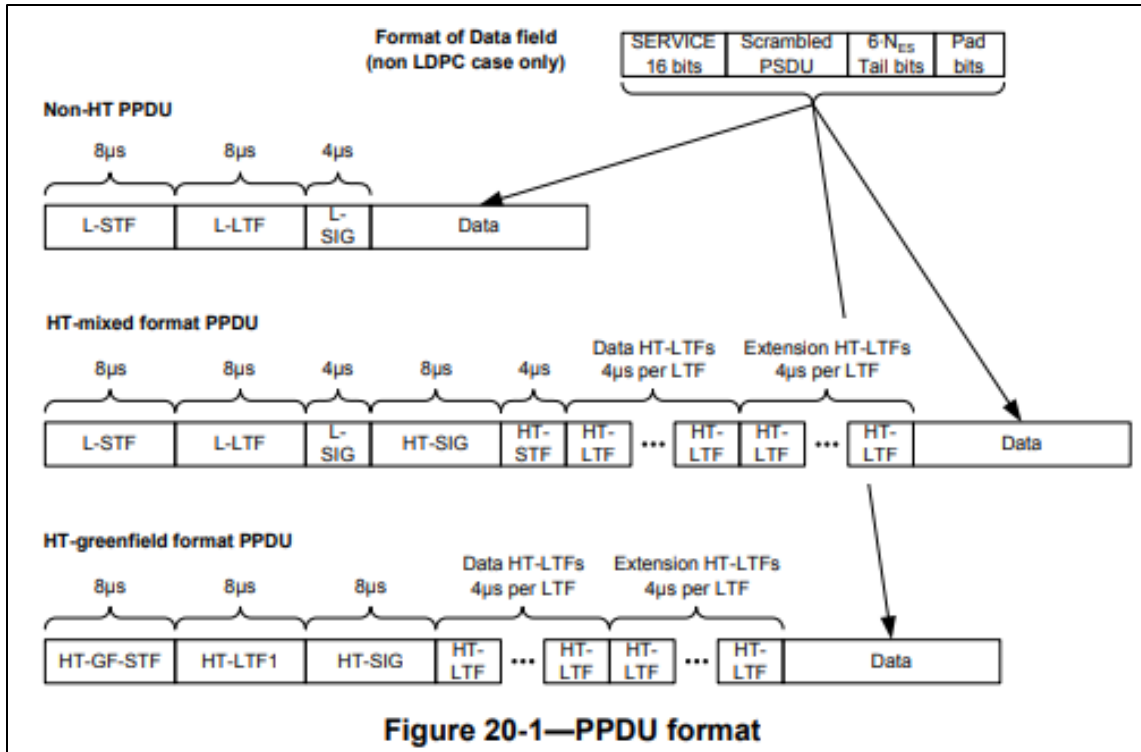

(Source: <https://web.archive.org/web/20190220214328/http://luci.subsignal.org/~jow/802.11n-2009.pdf>)

Table 20-4—Elements of the HT PLCP packet

Element	Description
L-STF	Non-HT Short Training field
L-LTF	Non-HT Long Training field
L-SIG	Non-HT SIGNAL field
HT-SIG	HT SIGNAL field
HT-STF	HT Short Training field
HT-GF-STF	HT-Greenfield Short Training field
HT-LTF1	First HT Long Training field (Data)
HT-LTFs	Additional HT Long Training fields (Data and Extension)
Data	The Data field includes the PSDU

(Source: <https://web.archive.org/web/20190220214328/http://luci.subsignal.org/~jow/802.11n-2009.pdf>)

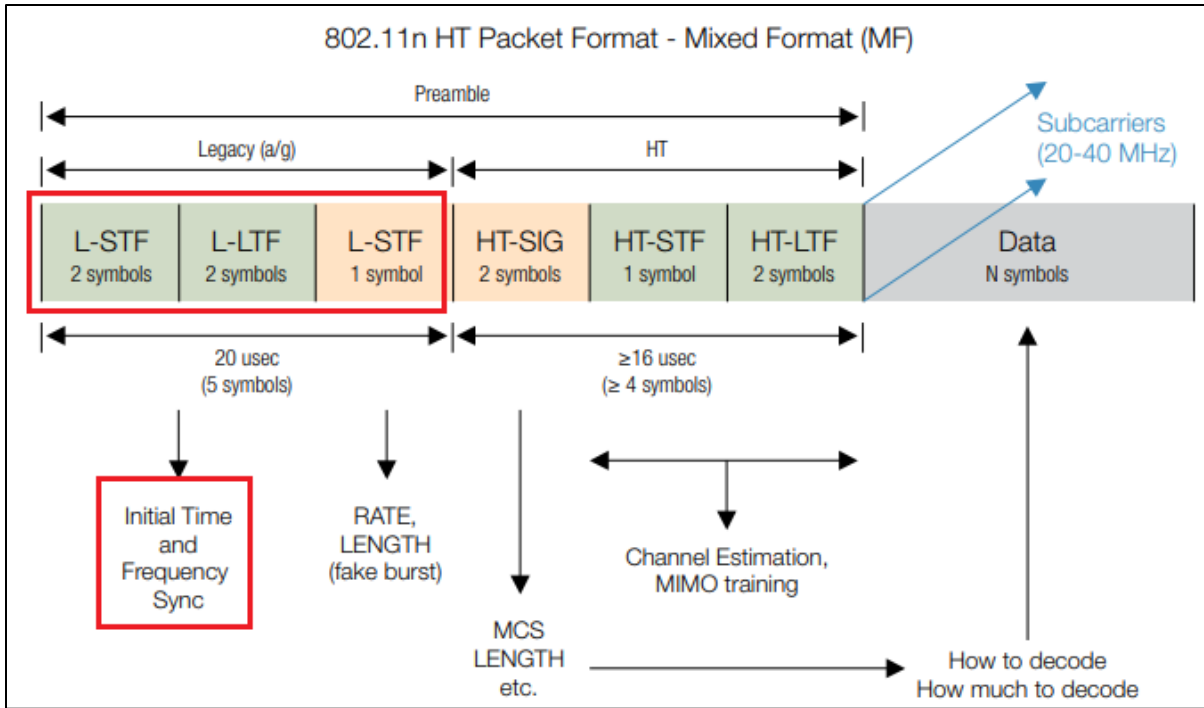

(Source: https://www.cnrood.com/en/media/solutions/Wi-Fi_Overview_of_the_802.11_Physical_Layer.pdf)

GI_TYPE	FORMAT is HT_MF or HT_GF	Indicates whether a short guard interval is used in the transmission of the packet. Enumerated type: LONG_GI indicates short GI is not used in the packet. SHORT_GI indicates short GI is used in the packet.	Y	Y
	Otherwise	Not present	N	N

(Source: <https://web.archive.org/web/20190220214328/http://luci.subsignal.org/~jow/802.11n-2009.pdf>)

22. The methods practiced by Qualcomm’s use of the accused products include transmitting the frame over a channel. The data frames containing the preambles are transmitted using one or more transmitting antennas. Alternatively, on request from an accused product, an 802.11 n/ac compliant WiFi access point can act as a transmitter and transmit the frame over a channel using one or more transmitting antennas.

20.3.9 HT preamble

20.3.9.1 Introduction

The HT preambles are defined in HT-mixed format and in HT-greenfield format to carry the required information to operate in a system with multiple transmit and multiple receive antennas.

In the HT-mixed format, to ensure compatibility with non-HT STAs, specific non-HT fields are defined so that they can be received by non-HT STAs compliant with Clause 17 or Clause 19 followed by the fields specific to HT STAs.

(Source: <https://web.archive.org/web/20190220214328/http://luci.subsignal.org/~jow/802.11n-2009.pdf>)

20.3.10 Transmission of NON_HT format PPDU with more than one antenna

When an HT device transmits a NON_HT format PPDU with the MODULATION parameter set to OFDM or ERP-OFDM using more than one transmit chain, it shall apply the cyclic shifts defined in Table 20-8 to the transmission in each chain.

(Source: <https://web.archive.org/web/20190220214328/http://luci.subsignal.org/~jow/802.11n-2009.pdf>)

23. The methods practiced by Qualcomm's use of the accused products include receiving the transmitted frame. For example, the receiving antennas of the accused products can receive the transmitted frames for further processing.

20.3.24 PLCP receive procedure

Typical PLCP receive procedures are shown in Figure 20-23 and Figure 20-24. The receive procedures correspond to HT-mixed format and HT-greenfield format, respectively. A typical state machine implementation of the receive PLCP is given in Figure 20-25. These receive procedures and state machine do not describe the operation of optional features, such as LDPC or STBC. If the detected format indicates a non-HT PPDU format, refer to the receive procedure and state machine in Clause 17 or Clause 19. Further, through station management (via the PLME), the PHY is set to the appropriate frequency, as specified in 20.4. Other receive parameters, such as RSSI and indicated DATARATE, may be accessed via the PHY-SAP.

(Source: <https://web.archive.org/web/20190220214328/http://luci.subsignal.org/~jow/802.11n-2009.pdf>)

24. The methods practiced by Qualcomm's use of the accused products include demodulating the received frame. For example, the received data frames are demodulated using the PLCP preambles.

20.3 HT PLCP sublayer

20.3.1 Introduction

A convergence procedure, in which PSDUs are converted to and from PPDU, is provided for the HT PHY in 20.3. During transmission, the PSDU is processed (i.e., scrambled and coded) and appended to the PLCP preamble to create the PPDU. At the receiver, the PLCP preamble is processed to aid in demodulation and delivery of the PSDU.

(Source: <https://web.archive.org/web/20190220214328/http://luci.subsignal.org/~jow/802.11n-2009.pdf>)

25. The methods practiced by Qualcomm's use of the accused products include synchronizing the received demodulated frame to the transmitted frame such that the data symbols are synchronized in the time domain and frequency domain. For example, different fields of data like training symbols, cyclic prefixes and other signal bits are present in the received frame. The training symbols (L-STF and L-LTF fields) help in synchronizing the frame in both the time domain and frequency domain.

Specifications	
Process Technology	14nm
<u>Wi-Fi Standards</u>	<u>Wi-Fi 7, Wi-Fi 6E, Wi-Fi 6 (802.11ax), 802.11ac wave 2, 802.11a/b/g, 802.11n</u>
Wi-Fi Spectral Bands	2.4GHz, 5GHz, 6GHz
Peak Speed	5.8 Gbps*
<u>Wi-Fi Features</u>	<u>4-Stream Dual Band Simultaneous in the High Bands,</u> 4K QAM, Multi-Link Operation (MLO), 320MHz (single channel, or 160 + 160), 8x8 Sounding, <u>MU-MIMO (Uplink and Downlink)</u> , OFDMA (Uplink and Downlink), Target Wake Time (TWT), Passpoint, Wi-Fi Aware R3, Wi-Fi Location, Wi-Fi Optimized Connectivity, Wi-Fi QoS Management, TDLS, Miracast, Voice-Enterprise

(Source : <https://www.qualcomm.com/media/documents/files/mwc-2022-qualcomm-fastconnect-7800-product-brief.pdf>)

Wi-Fi & Bluetooth
<ul style="list-style-type: none"> FastConnect 6900 System <ul style="list-style-type: none"> Wi-Fi Standards: Wi-Fi 6E, Wi-Fi 6 (802.11ax), Wi-Fi 5 (802.11ac), 802.11a/b/g/n Wi-Fi Spectral Bands: 2.4 GHz, 5 GHz, 6 GHz Peak speed: 3.6 Gbps Channel Utilization: 20/40/80/160 MHz 8-stream sounding (for 8x8 MU-MIMO) MIMO Configuration: 2x2 (2-stream) MU-MIMO (Uplink & Downlink) 4K QAM OFDMA (Uplink & Downlink) Dual-band simultaneous (2x2 + 2x2) Wi-Fi Security: WPA3-Enterprise, WPA3-Enhanced Open, WPA3 Easy Connect, WPA3-Personal

(Source :

https://www.qualcomm.com/system/files/document/files/prod_brief_qcom_sd888_5g_1_0.pdf)

Wi-Fi	Standards: 802.11ac Wave 2, 802.11a/b/g, 802.11n
	Wi-Fi Spectral Bands: 2.4 GHz, 5 GHz
	Peak Speed: 620 Mbps
	Channel Utilization: 20/40/80 MHz
	MIMO Configuration: 2x2 (2-stream)
	Wi-Fi Features: MU-MIMO, TxBF

(Source : <https://www.qualcomm.com/products/technology/wi-fi/qca9379>)

- a) Determine the number of transmit chains, N_{TX} , from the N_TX field of the TXVECTOR. Produce the PLCP preamble training fields for each of the N_{TX} transmit chains based on the FORMAT, NUM_EXTEN_SS, CH_BANDWIDTH, and MCS parameters of the TXVECTOR. The format and relative placement of the PLCP preamble training fields vary depending on the frame format being used, as indicated by these parameters. Apply cyclic shifts. Determine spatial mapping to be used for HT-STF and HT-LTFs in HT-mixed format frame and HT-GF-STF and HT-LTFs in HT-greenfield format frame from the EXPANSION_MAT parameter of the TXVECTOR. Refer to 20.3.9 for details.
- b) Construct the PLCP preamble SIGNAL fields from the appropriate fields of the TXVECTOR by adding tail bits, applying convolutional coding, formatting into one or more OFDM symbols, applying cyclic shifts, applying spatial processing, calculating an inverse Fourier transform for each OFDM symbol and transmit chain, and prepending a cyclic prefix or GI to each OFDM symbol in each transmit chain. The number and placement of the PLCP preamble SIGNAL fields depend on the frame format being used. Refer to 20.3.9.3.5, 20.3.9.4.3, and 20.3.9.5.3.
- c) Concatenate the PLCP preamble training and SIGNAL fields for each transmit chain one field after another, in the appropriate order, as described in 20.3.2 and 20.3.7.

(Source: [https://web.archive.org/web/20190220214328/http://luci.subsignal.org/~jow/802.11n-](https://web.archive.org/web/20190220214328/http://luci.subsignal.org/~jow/802.11n-2009.pdf)

[2009.pdf](https://web.archive.org/web/20190220214328/http://luci.subsignal.org/~jow/802.11n-2009.pdf))

20.3.21.7.4 Transmitter modulation accuracy (EVM) test

The transmit modulation accuracy test shall be performed by instrumentation capable of converting the transmitted signals into a streams of complex samples at 40 Msample/s or more, with sufficient accuracy in terms of I/Q arm amplitude and phase balance, dc offsets, phase noise, and analog-to-digital quantization noise. Each transmit chain is connected directly through a cable to the setup input port. A possible embodiment of such a setup is converting the signals to a low intermediate frequency with a microwave synthesizer, sampling the signal with a digital oscilloscope, and decomposing it digitally into quadrature components. The sampled signal shall be processed in a manner similar to an actual receiver, according to the following steps, or an equivalent procedure:

- a) Detect the start of frame.
- b) Detect the transition from short sequences to channel estimation sequences, and establish fine timing (with one sample resolution).
- c) Estimate the coarse and fine frequency offsets.
- d) Derotate the frame according to estimated frequency offset.
- e) Estimate the complex channel response coefficients for each of the subcarriers and each of the transmit chains.
- f) For each of the data OFDM symbols, transform the symbol into subcarrier received values, estimate the phase from the pilot subcarriers in all spatial streams, derotate the subcarrier values according to estimated phase, group the results from all the receiver chains in each subcarrier to a vector, multiply the vector by a zero-forcing equalization matrix generated from the channel estimated during the channel estimation phase.
- g) For each data-carrying subcarrier in each spatial stream, find the closest constellation point and compute the Euclidean distance from it.
- h) Compute the average of the RMS of all errors in a frame. It is given by Equation (20-89).

(Source: <https://web.archive.org/web/20190220214328/http://luci.subsignal.org/~jow/802.11n-2009.pdf>)

17.3.2.1 Overview of the PPDU encoding process

The encoding process is composed of many detailed steps, which are described fully in later subclauses, as noted below. The following overview intends to facilitate understanding the details of the convergence procedure:

- a) Produce the PLCP Preamble field, composed of 10 repetitions of a “short training sequence” (used for AGC convergence, diversity selection, timing acquisition, and coarse frequency acquisition in the receiver) and two repetitions of a “long training sequence” (used for channel estimation and fine frequency acquisition in the receiver), preceded by a guard interval (GI). Refer to 17.3.3 for details.

(Source: <https://www.iith.ac.in/~tbr/teaching/docs/802.11-2007.pdf>)

26. The methods practiced by Qualcomm's use of the accused products include wherein the synchronizing in the time domain comprises coarse time synchronizing and fine time synchronizing. For example, the demodulation of PPDU frames also includes detecting training field bits and establishing a timing synchronization. This time synchronization would include both coarse and fine time synchronization. In general, coarse time synchronization is done using L-STF field and fine time synchronization is done using L-LTF field present in the preamble.

20.3.21.7.4 Transmitter modulation accuracy (EVM) test

The transmit modulation accuracy test shall be performed by instrumentation capable of converting the transmitted signals into a streams of complex samples at 40 Msample/s or more, with sufficient accuracy in terms of I/Q arm amplitude and phase balance, dc offsets, phase noise, and analog-to-digital quantization noise. Each transmit chain is connected directly through a cable to the setup input port. A possible embodiment of such a setup is converting the signals to a low intermediate frequency with a microwave synthesizer, sampling the signal with a digital oscilloscope, and decomposing it digitally into quadrature components. The sampled signal shall be processed in a manner similar to an actual receiver, according to the following steps, or an equivalent procedure:

- a) Detect the start of frame.
- b) Detect the transition from short sequences to channel estimation sequences, and establish fine timing (with one sample resolution).
- c) Estimate the coarse and fine frequency offsets.
- d) Derotate the frame according to estimated frequency offset.
- e) Estimate the complex channel response coefficients for each of the subcarriers and each of the transmit chains.
- f) For each of the data OFDM symbols, transform the symbol into subcarrier received values, estimate the phase from the pilot subcarriers in all spatial streams, derotate the subcarrier values according to estimated phase, group the results from all the receiver chains in each subcarrier to a vector, multiply the vector by a zero-forcing equalization matrix generated from the channel estimated during the channel estimation phase.
- g) For each data-carrying subcarrier in each spatial stream, find the closest constellation point and compute the Euclidean distance from it.
- h) Compute the average of the RMS of all errors in a frame. It is given by Equation (20-89).

(Source: <https://web.archive.org/web/20190220214328/http://luci.subsignal.org/~jow/802.11n-2009.pdf>)

The simplest packet is the one used when operating in the legacy mode, which has the same format as the packets used in 802.11a/g. The L-STF field, which stands for the *legacy-short training field*, consists of two augmented OFDM symbols of 4 μ s duration each, and these are used by the receiver to perform time and frequency synchronization and to adjust its AGC. After the two L-STF augmented OFDM symbols, there is a second field called L-LTF, which stands for *legacy-long training field*, which is used to perform fine timing adjustments after the initial coarse acquisition in the L-STF field. The third field, called L-SIG, which stands for *legacy signal field*, contains data that tell the receiver what modulation and coding will be used in the data portion of the packet. The L-SIG field consists of one augmented OFDM symbol.

(Source: Introduction to MIMO Communications, Hampton, Jerry R. (2014))

Receive procedure

Typically, the receiver waits for a signal to exceed a threshold before initiating the packet reception procedure. The minimum requirement in 802.11a is to detect the start of a valid transmission received at a power level of at least -82 dBm within 4 μ s with a probability greater than 90%. Due to competitive pressures, most products exceed this specification by 5–10 dB.

The short training symbols are processed to set the AGC, initial frequency correction, and initial timing acquisition. This is followed by processing the long training symbols for fine frequency correction and fine timing adjustment. The LTF is also used to generate the channel estimate.

(Source: Next Generation Wireless LANs: 802.11n and 802.11ac, Perahia, Eldad and Stacey, Robert)

27. Qualcomm has directly infringed at least through its use of the accused products through its own testing of the accused products, and through joint infringement with its affiliates, with its subsidiaries, with carriers, with retailers and other sales entities, with its business partners, with certification organizations, with testing organizations, with other agents of Qualcomm, and/or with its customers and end-users, at least using the claimed method. Such acts of infringement include directing or controlling other persons to engage in conduct

satisfying one or more elements of the asserted claims, deriving a financial or other benefit from doing so. Qualcomm's direction or control of its affiliates and end-users includes regularly contracting with those affiliates and end-users. Also, as explained further below, Qualcomm took active steps and advised or directed customers and end-users to use the accused products in an infringing manner.

28. Qualcomm has had knowledge of the '782 Patent at least as of November 21, 2008, when the '782 Patent was used in the first of five office actions during prosecution of U.S. Patent Application No. 11/313,555. That application issued as U.S. Patent No. 8,130,726, titled "Coarse Bin Frequency Synchronization In A Communication System" and was assigned to Qualcomm Inc. The examiner during that prosecution explained that "Mody teaches an OFDM system that has multiple frequency offset estimation circuits/calculators (e.g. identifies and offsets frequency errors). There are Coarse and Fine Synchronization circuits as well as first/second/etc. offset estimation circuits. (see figure 8. Notice that these components are all contained in a Synchronization Circuit)." Qualcomm employee Kuei-Chiang Lai, who is listed as an inventor on U.S. Patent No. 8,130,726, and others involved in the prosecution of the patent, have had knowledge of the '782 Patent at least as of November 21, 2008.

29. Qualcomm has had knowledge of the '782 Patent at least as of April 6, 2009, when the '782 Patent was cited and described by the examiner ("Mody et al (US Pat. No. 7,088,782) discloses a coarse and fine frequency synchronization wherein an OFDM signal frequency offset is estimated, corrected, and transmitted for further signal processing prior to being refined in a second frequency offset estimation and correction stage.") during the prosecution of U.S. Patent Application No. 11/322,538. That application issued as U.S. Patent No. 7,558,245, titled "Method And Apparatus For Time And Frequency Synchronization Of

OFDM Communication Systems” and was assigned to Qualcomm Inc. Qualcomm employees Rajiv Laroia, Junyi Li, Sundeep Rangan, and Hemanth T. Sampath, who are listed as inventors on U.S. Patent No. 7,558,245, and others involved in the prosecution of the patent, including Michael P. Straub, have had knowledge of the ‘782 Patent at least as of April 6, 2009.

30. Qualcomm has also cited the ‘782 Patent during the prosecution of at least five other patents. For example, Qualcomm has had knowledge of the ‘782 Patent at least as of October 13, 2009, when it cited the ‘782 Patent in an Information Disclosure Statement during the prosecution of U.S. Patent Application No. 12/552,705. That application issued as U.S. Patent No. 8,743,837, titled “Modified Preamble Structure For IEEE 802.11A Extensions To Allow For Coexistence And Interoperability Between 802.11A Devices And Higher Data Rate, MIMO Or Otherwise Extended Devices” and was assigned to Qualcomm Inc. Qualcomm employees Albert van Zelst and Richard van Nee, who are listed as inventors on U.S. Patent No. 8,743,837, and others involved in the prosecution of the patent, have had knowledge of the ‘782 Patent at least as of October 13, 2009.

31. Likewise, Qualcomm has had knowledge of the ‘782 Patent at least as of March 13, 2012, when it cited the ‘782 Patent in an Information Disclosure Statement during the prosecution of U.S. Patent Application No. 12/469,323. That application issued as U.S. Patent No. 8,457,232, titled “Detecting The Number Of Transmit Antennas In Wireless Communication Systems” and was assigned to Qualcomm Inc. Qualcomm employees Albert van Zelst and Richard van Nee, who are listed as inventors on U.S. Patent No. 8,457,232, and others involved in the prosecution of the patent, including Thomas E. Watson and William E. Curry, have had knowledge of the ‘782 Patent at least as of March 13, 2012.

32. Qualcomm has had actual knowledge of the ‘782 Patent at least as of the date when it was notified of the filing of this action. By the time of trial, Qualcomm will have known and intended (since receiving such notice) that its continued actions would infringe and actively induce and contribute to the infringement of one or more claims of the ‘782 Patent.

33. Qualcomm has also indirectly and willfully infringed, and continues to indirectly and willfully infringe, the ‘782 Patent, as explained further below in the “Additional Allegations Regarding Infringement and Personal Jurisdiction” section.

34. American Patents has been damaged as a result of the infringing conduct by Qualcomm alleged above. Thus, Qualcomm is liable to American Patents in an amount that adequately compensates it for such infringements, which, by law, cannot be less than a reasonable royalty, together with interest and costs as fixed by this Court under 35 U.S.C. § 284.

35. American Patents has neither made nor sold unmarked articles that practice the ‘782 Patent, and is entitled to collect pre-filing damages for the full period allowed by law for infringement of the ‘782 Patent.

COUNT II

INFRINGEMENT OF U.S. PATENT NO. 7,310,304

36. On December 18, 2007, United States Patent No. 7,310,304 (“the ‘304 Patent”) was duly and legally issued by the United States Patent and Trademark Office for an invention entitled “Estimating Channel Parameters in Multi-Input, Multi-Output (MIMO) Systems.”

37. American Patents is the owner of the ‘304 Patent, with all substantive rights in and to that patent, including the sole and exclusive right to prosecute this action and enforce the ‘304 Patent against infringers, and to collect damages for all relevant times.

38. Qualcomm made, had made, used, imported, provided, supplied, distributed, sold, and/or offered for sale products and/or systems including, for example, its Qualcomm FastConnect 7800 (with 4x4 MIMO), Qualcomm Snapdragon 888 5G Mobile Platform (with 2x2 MIMO), and Qualcomm QCA9379 (with 2x2 MIMO) families of products that include 802.11n and above and/or LTE capabilities (“accused products”):

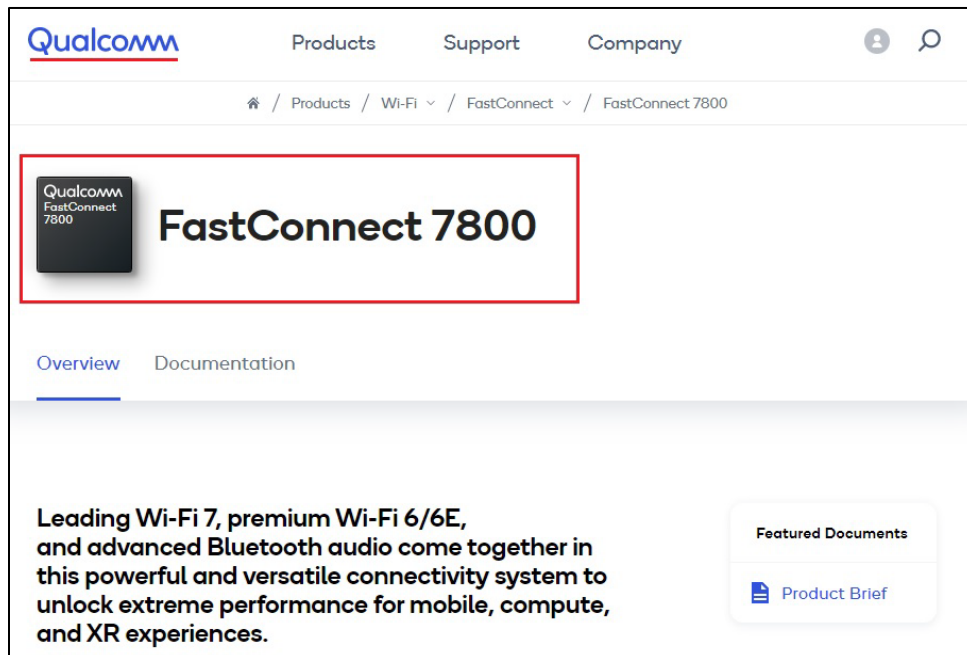

(Source : <https://www.qualcomm.com/products/fastconnect-7800>)

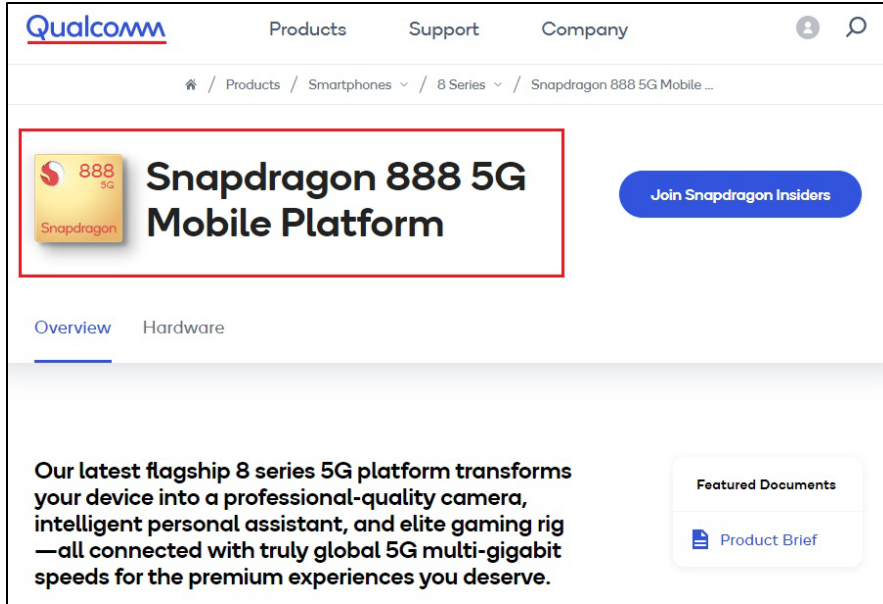

(Source : <https://www.qualcomm.com/products/snapdragon-888-5g-mobile-platform>)

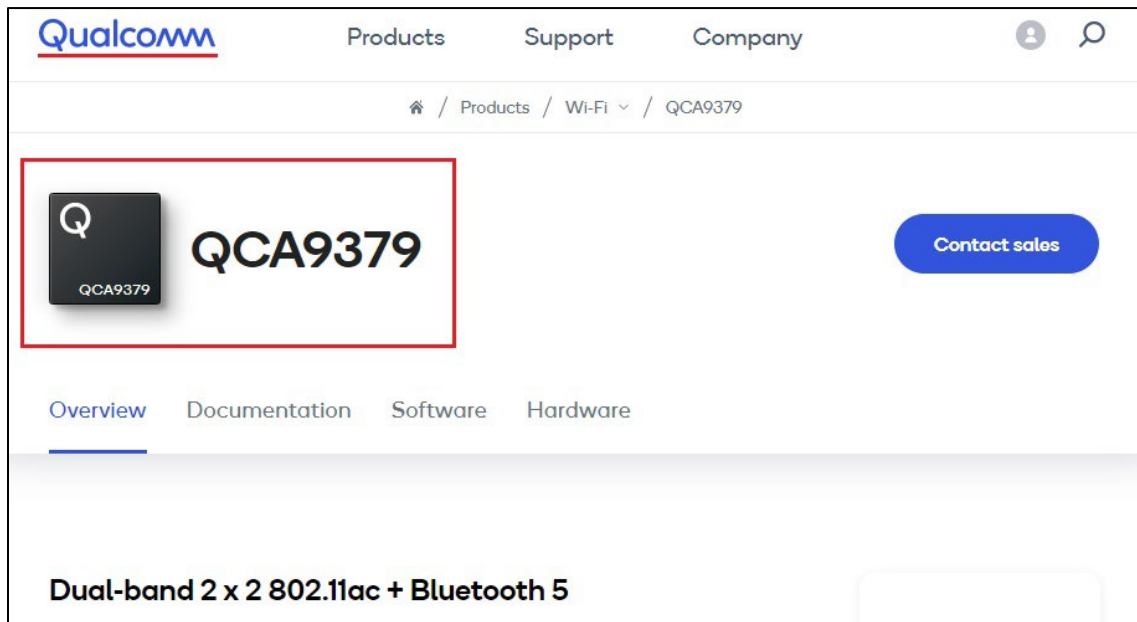

(Source : <https://www.qualcomm.com/products/technology/wi-fi/qca9379>)

Specifications	
Process Technology	14nm
<u>Wi-Fi Standards</u>	<u>Wi-Fi 7, Wi-Fi 6E, Wi-Fi 6 (802.11ax), 802.11ac wave 2, 802.11a/b/g, 802.11n</u>
Wi-Fi Spectral Bands	2.4GHz, 5GHz, 6GHz
Peak Speed	5.8 Gbps*
<u>Wi-Fi Features</u>	<u>4-Stream Dual Band Simultaneous in the High Bands,</u> 4K QAM, Multi-Link Operation (MLO), 320MHz (single channel, or 160 + 160), 8x8 Sounding, <u>MU-MIMO (Uplink and Downlink)</u> , OFDMA (Uplink and Downlink), Target Wake Time (TWT), Passpoint, Wi-Fi Aware R3, Wi-Fi Location, Wi-Fi Optimized Connectivity, Wi-Fi QoS Management, TDLS, Miracast, Voice-Enterprise

(Source : <https://www.qualcomm.com/media/documents/files/mwc-2022-qualcomm-fastconnect-7800-product-brief.pdf>)

Wi-Fi & Bluetooth
<ul style="list-style-type: none"> • FastConnect 6900 System <ul style="list-style-type: none"> • <u>Wi-Fi Standards: Wi-Fi 6E, Wi-Fi 6 (802.11ax), Wi-Fi 5 (802.11ac), 802.11a/b/g/n</u> • Wi-Fi Spectral Bands: 2.4 GHz, 5 GHz, 6 GHz • Peak speed: 3.6 Gbps • Channel Utilization: 20/40/80/160 MHz • <u>8-stream sounding (for 8x8 MU-MIMO)</u> • <u>MIMO Configuration: 2x2 (2-stream)</u> • MU-MIMO (Uplink & Downlink) • 4K QAM • OFDMA (Uplink & Downlink) • Dual-band simultaneous (2x2 + 2x2) • Wi-Fi Security: WPA3-Enterprise, WPA3-Enhanced Open, WPA3 Easy Connect, WPA3-Personal

(Source :

https://www.qualcomm.com/system/files/document/files/prod_brief_qcom_sd888_5g_1_0.pdf)

Wi-Fi	Standards: 802.11ac Wave 2, 802.11a/b/g, 802.11n
	Wi-Fi Spectral Bands: 2.4 GHz, 5 GHz
	Peak Speed: 620 Mbps
	Channel Utilization: 20/40/80 MHz
	MIMO Configuration: 2x2 (2-stream)
	Wi-Fi Features: MU-MIMO, TxBF

(Source : <https://www.qualcomm.com/products/technology/wi-fi/qca9379>)

39. By doing so, Qualcomm has directly infringed (literally and/or under the doctrine of equivalents) at least Claim 1 of the ‘304 Patent. Qualcomm’s infringement in this regard is ongoing.

40. Qualcomm has infringed the ‘304 Patent by making, having made, using, importing, providing, supplying, distributing, selling or offering for sale products including an Orthogonal Frequency Division Multiplexing (OFDM) transmitter. For example, the accused products support IEEE 802.11 n/ac standards and MIMO technology. The IEEE 802.11n standard “uses OFDM modulation to transmit all data.”

The 802.11n-2009 wireless LAN standard provides Higher Throughput (HT) rates. These higher rates are achieved by a combination of MAC and PHY layer enhancements. The enhancements include:

- Reducing the per-packet overhead in the MAC layer.
- Allowing multiple MAC packets to be combined into a single PHY-layer burst.
- Allowing (optionally) a more efficient LDPC encoder.
- Allowing (optionally) a shorter guard interval (cyclic prefix) on the data symbols.
- Increasing the number of subcarriers used in the default 20 MHz physical channel.
- Providing an (optional) 40 MHz mode.
- Using MIMO techniques to broadcast multiple data streams over a single frequency channel.

By combining these techniques, the goal is to increase the usable data transfer rate by a factor of 10.

Signal Characteristics

The 802.11n standard uses OFDM modulation to transmit all data. It defines three operating modes:

(Source: http://rfmw.em.keysight.com/wireless/helpfiles/89600b/webhelp/subsystems/wlan-mimo/Content/mimo_80211n_overview.htm)

41. The accused products include an encoder configured to process data to be transmitted within an OFDM system, the encoder further configured to separate the data onto one or more transmit diversity branches (TDBs). For example, the 802.11 ac standard is backwards compatible with 802.11n and 802.11a. Thus, if a device, such as an accused product, implements 802.11ac, then it also supports 802.11n and all previous versions of the WiFi standards (i.e., IEEE 802.11 a/b/g/n). According to the IEEE 802.11n standard, an encoder block is present in a transmitter section of general OFDM systems. The encoder(s) output(s) the data onto multiple transmit chains (transmit diversity branches) for further processing.

The introduction of 802.11ac expands the compatibility matrix in the 5 GHz band from two concurrently operating technologies to three, and the compatibility considerations in a broadcast network medium extend not only to intended receivers but to any receiver. Table 3-4 describes the compatibility between transmitters of frames and their intended receivers. That is, if a transmitter of the type in the left column sends a frame directed to a receiver of the type in any of the other three columns, what will the result be? One of the major methods used to support coexistence is backward compatibility. When built, 802.11ac devices will also incorporate 802.11a and 802.11n data rates, and thus will be able to send to older peers at older data rates.

(Source: 802.11ac: A Survival Guide: Wi-Fi at Gigabit and Beyond, Gast, Matthew S.)

Table 3-5. Compatibility between transmitters and listening devices

Transmitter type	802.11a listener	802.11n listener	802.11ac listener
802.11a	Designed operation	802.11n devices listen to 802.11a frames and defer medium access to avoid collisions	802.11ac devices listen to 802.11a frames and defer medium access to avoid collisions
802.11n	802.11n greenfield frames require RTS/CTS or CTS-to-self protection; 802.11n mixed-mode frames require no special protection	Designed operation	802.11ac devices listen to 802.11n frames and defer medium access to avoid collisions
802.11ac	802.11ac uses a compatible physical preamble, allowing 802.11a devices to read the medium as busy and avoid collisions	802.11ac uses a compatible preamble, allowing 802.11n devices to read the medium as busy and avoid collisions	Designed operation

(Source: 802.11ac: A Survival Guide: Wi-Fi at Gigabit and Beyond, Gast, Matthew S.)

20.3.3 Transmitter block diagram

HT-mixed format and HT-greenfield format transmissions can be generated using a transmitter consisting of the following blocks:

- a) *Scrambler* scrambles the data to reduce the probability of long sequences of zeros or ones; see 20.3.11.2.
- b) *Encoder parser*, if BCC encoding is to be used, demultiplexes the scrambled bits among N_{ES} (number of BCC encoders for the Data field) BCC encoders, in a round robin manner.
- c) *FEC encoders* encode the data to enable error correction. An FEC encoder may include a binary convolutional encoder followed by a puncturing device, or it may include an LDPC encoder.
- d) *Stream parser* divides the outputs of the encoders into blocks that are sent to different interleaver and mapping devices. The sequence of the bits sent to an interleaver is called a *spatial stream*.
- e) *Interleaver* interleaves the bits of each spatial stream (changes order of bits) to prevent long sequences of adjacent noisy bits from entering the BCC decoder. Interleaving is applied only when BCC encoding is used.
- f) *Constellation mapper* maps the sequence of bits in each spatial stream to constellation points (complex numbers).
- g) *STBC* encoder spreads constellation points from N_{SS} spatial streams into N_{STS} space-time streams using a space-time block code. STBC is used only when $N_{SS} < N_{STS}$; see 20.3.11.8.1.
- h) *Spatial mapper* maps space-time streams to transmit chains. This may include one of the following:
 - 1) *Direct mapping*: Constellation points from each space-time stream are mapped directly onto the transmit chains (one-to-one mapping).

(Source: <https://web.archive.org/web/20190220214328/http://luci.subsignal.org/~jow/802.11n-2009.pdf>)

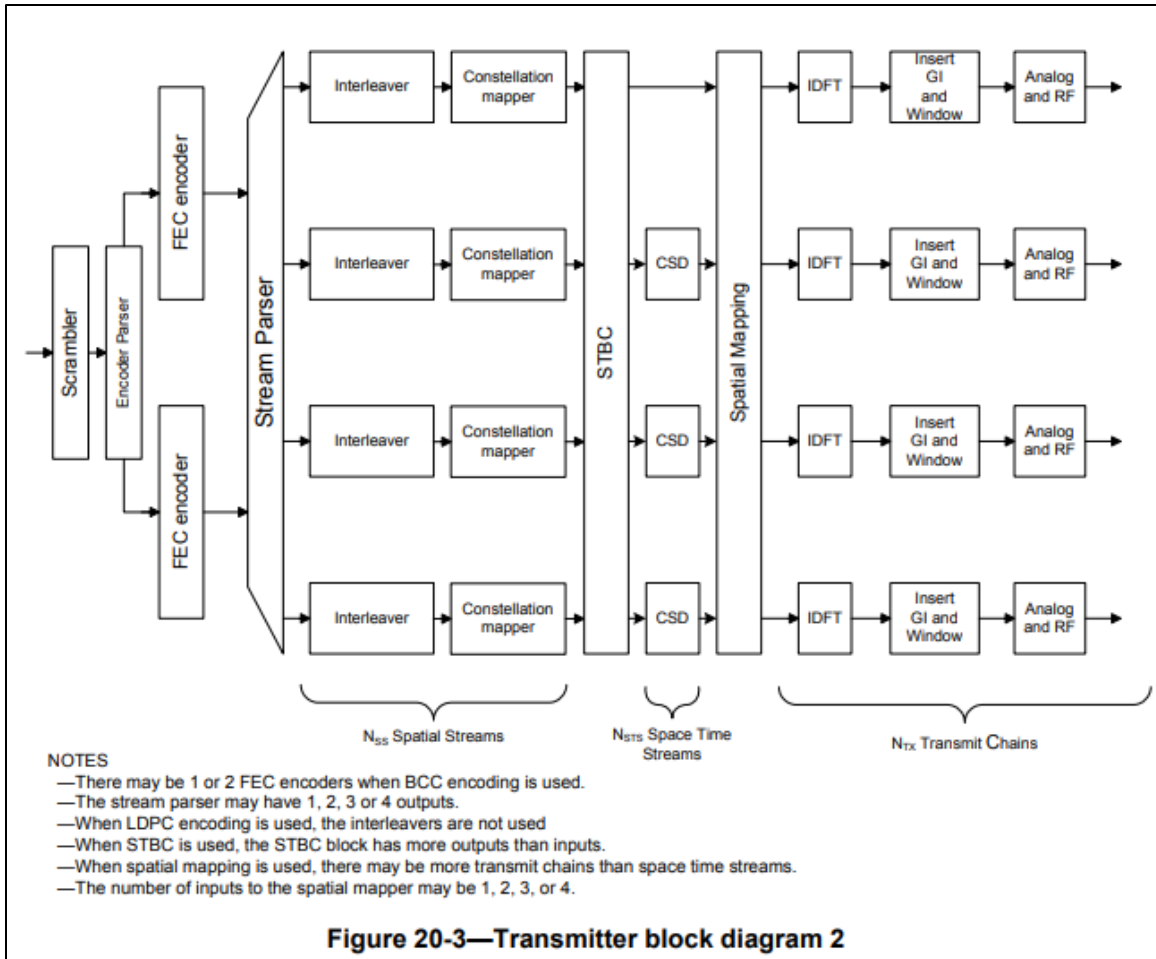

(Source: <https://web.archive.org/web/20190220214328/http://luci.subsignal.org/~jow/802.11n-2009.pdf>)

42. The accused products include one or more OFDM modulators, each OFDM modulator connected to a respective TDB, each OFDM modulator configured to produce a frame including a plurality of data symbols, a training structure, and cyclic prefixes inserted among the data symbols. For example, according to the IEEE 802.11n standard, a transmitter block would contain different functional blocks which include constellation mappers, IDFT stage, and Guard interval insertion. The constellation mapper maps the bits and the constellation points for different modulation schemes like QPSK, BPSK, 16-QAM, and 64-QAM. Hence, there would be modulator blocks for performing the modulation. After modulating the signal, it is converted

into the time domain and is transmitted as frames of data. These transmitted frames include a training structure, signal bits, cyclic prefixes and data bits.

20.3.3 Transmitter block diagram

HT-mixed format and HT-greenfield format transmissions can be generated using a transmitter consisting of the following blocks:

- a) *Scrambler* scrambles the data to reduce the probability of long sequences of zeros or ones; see 20.3.11.2.
- b) *Encoder parser*, if BCC encoding is to be used, demultiplexes the scrambled bits among N_{ES} (number of BCC encoders for the Data field) BCC encoders, in a round robin manner.
- c) *FEC encoders* encode the data to enable error correction. An FEC encoder may include a binary convolutional encoder followed by a puncturing device, or it may include an LDPC encoder.
- d) *Stream parser* divides the outputs of the encoders into blocks that are sent to different interleaver and mapping devices. The sequence of the bits sent to an interleaver is called a *spatial stream*.
- e) *Interleaver* interleaves the bits of each spatial stream (changes order of bits) to prevent long sequences of adjacent noisy bits from entering the BCC decoder. Interleaving is applied only when BCC encoding is used.
- f) *Constellation mapper* maps the sequence of bits in each spatial stream to constellation points (complex numbers).
- g) *STBC encoder* spreads constellation points from N_{SS} spatial streams into N_{STS} space-time streams using a space-time block code. STBC is used only when $N_{SS} < N_{STS}$; see 20.3.11.8.1.
- h) *Spatial mapper* maps space-time streams to transmit chains. This may include one of the following:
 - 1) *Direct mapping*: Constellation points from each space-time stream are mapped directly onto the transmit chains (one-to-one mapping).

(Source: <https://web.archive.org/web/20190220214328/http://luci.subsignal.org/~jow/802.11n-2009.pdf>)

The encoding process is composed of the steps described below. The following overview is intended to facilitate an understanding of the details of the convergence procedure:

- a) Determine the number of transmit chains, N_{TX} , from the N_TX field of the TXVECTOR. Produce the PLCP preamble training fields for each of the N_{TX} transmit chains based on the FORMAT, NUM_EXTEN_SS, CH_BANDWIDTH, and MCS parameters of the TXVECTOR. The format and relative placement of the PLCP preamble training fields vary depending on the frame format being used, as indicated by these parameters. Apply cyclic shifts. Determine spatial mapping to be used for HT-STF and HT-LTFs in HT-mixed format frame and HT-GF-STF and HT-LTFs in HT-greenfield format frame from the EXPANSION_MAT parameter of the TXVECTOR. Refer to 20.3.9 for details.
- b) Construct the PLCP preamble SIGNAL fields from the appropriate fields of the TXVECTOR by adding tail bits, applying convolutional coding, formatting into one or more OFDM symbols, applying cyclic shifts, applying spatial processing, calculating an inverse Fourier transform for each OFDM symbol and transmit chain, and prepending a cyclic prefix or GI to each OFDM symbol in each transmit chain. The number and placement of the PLCP preamble SIGNAL fields depend on the frame format being used. Refer to 20.3.9.3.5, 20.3.9.4.3, and 20.3.9.5.3.
- c) Concatenate the PLCP preamble training and SIGNAL fields for each transmit chain one field after another, in the appropriate order, as described in 20.3.2 and 20.3.7.

(Source: <https://web.archive.org/web/20190220214328/http://luci.subsignal.org/~jow/802.11n-2009.pdf>)

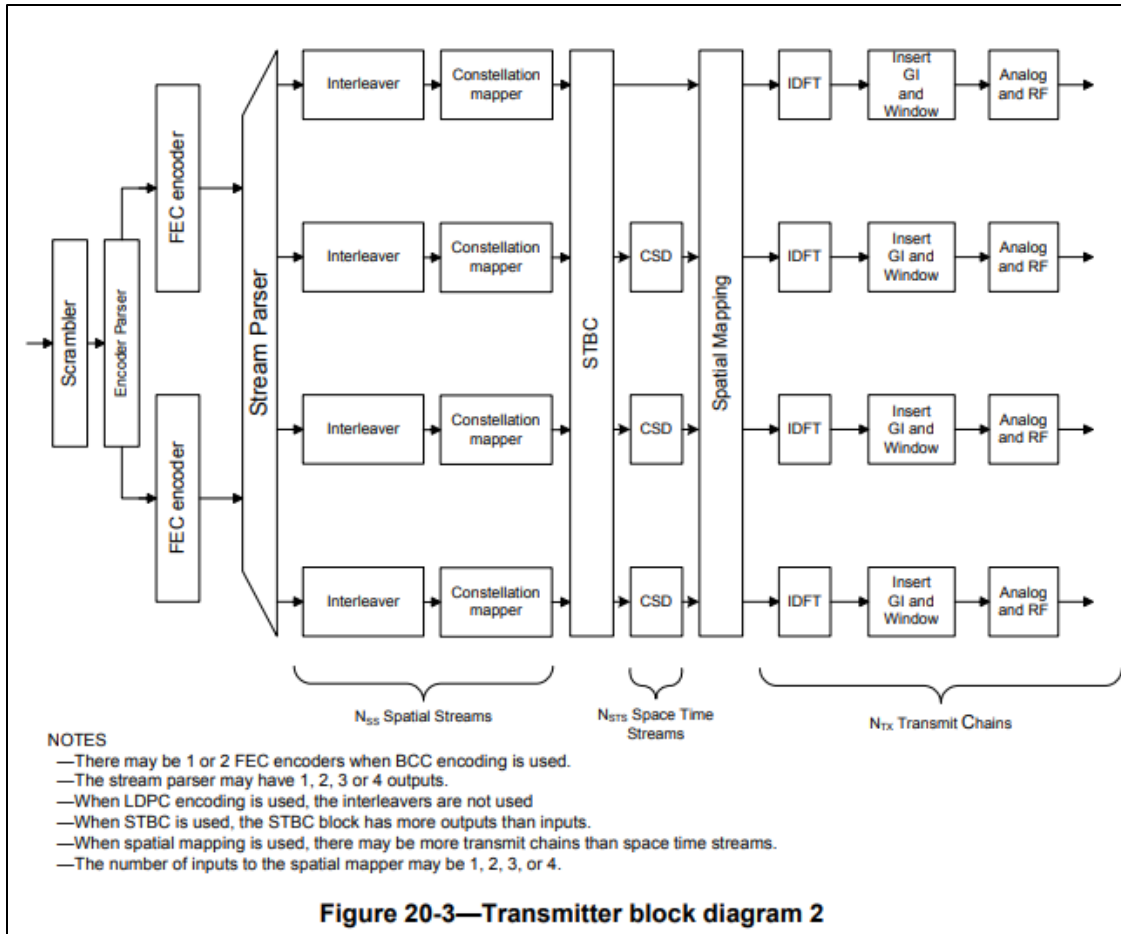

(Source: <https://web.archive.org/web/20190220214328/http://luci.subsignal.org/~jow/802.11n-2009.pdf><http://luci.subsignal.org/~jow/802.11n-2009.pdf>)

43. The accused products include one or more transmitting antennas in communication with the one or more OFDM modulators, respectively, each transmitting antenna configured to transmit the respective frame over a channel. The accused products support 802.11 a/b/g/n/ac WiFi standards and comprise one or more transmitting and one or more receiving antennas. These transmitting antennas transmit multiple OFDM frames with various signal fields over a channel. Thus, these transmitting antennas are connected to the OFDM modulators to obtain the OFDM frames for further transmission.

Specifications	
Process Technology	14nm
<u>Wi-Fi Standards</u>	<u>Wi-Fi 7, Wi-Fi 6E, Wi-Fi 6 (802.11ax), 802.11ac wave 2, 802.11a/b/g, 802.11n</u>
Wi-Fi Spectral Bands	2.4GHz, 5GHz, 6GHz
Peak Speed	5.8 Gbps*
<u>Wi-Fi Features</u>	<u>4-Stream Dual Band Simultaneous in the High Bands,</u> 4K QAM, Multi-Link Operation (MLO), 320MHz (single channel, or 160 + 160), 8x8 Sounding, <u>MU-MIMO (Uplink and Downlink)</u> , OFDMA (Uplink and Downlink), Target Wake Time (TWT), Passpoint, Wi-Fi Aware R3, Wi-Fi Location, Wi-Fi Optimized Connectivity, Wi-Fi QoS Management, TDLS, Miracast, Voice-Enterprise

(Source : <https://www.qualcomm.com/media/documents/files/mwc-2022-qualcomm-fastconnect-7800-product-brief.pdf>)

Wi-Fi & Bluetooth
<ul style="list-style-type: none"> FastConnect 6900 System <ul style="list-style-type: none"> Wi-Fi Standards: Wi-Fi 6E, Wi-Fi 6 (802.11ax), Wi-Fi 5 (802.11ac), 802.11a/b/g/n Wi-Fi Spectral Bands: 2.4 GHz, 5 GHz, 6 GHz Peak speed: 3.6 Gbps Channel Utilization: 20/40/80/160 MHz 8-stream sounding (for 8x8 MU-MIMO) MIMO Configuration: 2x2 (2-stream) MU-MIMO (Uplink & Downlink) 4K QAM OFDMA (Uplink & Downlink) Dual-band simultaneous (2x2 + 2x2) Wi-Fi Security: WPA3-Enterprise, WPA3-Enhanced Open, WPA3 Easy Connect, WPA3-Personal

(Source :

https://www.qualcomm.com/system/files/document/files/prod_brief_qcom_sd888_5g_1_0.pdf)

Wi-Fi	<p>Standards: 802.11ac Wave 2, 802.11a/b/g, 802.11n</p> <p>Wi-Fi Spectral Bands: 2.4 GHz, 5 GHz</p> <p>Peak Speed: 620 Mbps</p> <p>Channel Utilization: 20/40/80 MHz</p> <p>MIMO Configuration: 2x2 (2-stream)</p> <p>Wi-Fi Features: MU-MIMO, TxBF</p>
--------------	---

(Source : <https://www.qualcomm.com/products/technology/wi-fi/qca9379>)

The 802.11n-2009 wireless LAN standard provides Higher Throughput (HT) rates. These higher rates are achieved by a combination of MAC and PHY layer enhancements. The enhancements include:

- Reducing the per-packet overhead in the MAC layer.
- Allowing multiple MAC packets to be combined into a single PHY-layer burst.
- Allowing (optionally) a more efficient LDPC encoder.
- Allowing (optionally) a shorter guard interval (cyclic prefix) on the data symbols.
- Increasing the number of subcarriers used in the default 20 MHz physical channel.
- Providing an (optional) 40 MHz mode.
- Using MIMO techniques to broadcast multiple data streams over a single frequency channel.

By combining these techniques, the goal is to increase the usable data transfer rate by a factor of 10.

Signal Characteristics

The 802.11n standard uses OFDM modulation to transmit all data. It defines three operating modes:

(Source: http://rfmw.em.keysight.com/wireless/helpfiles/89600b/webhelp/subsystems/wlan-mimo/Content/mimo_80211n_overview.htm)

20.3.4 Overview of the PPDU encoding process

The encoding process is composed of the steps described below. The following overview is intended to facilitate an understanding of the details of the convergence procedure:

- a) Determine the number of transmit chains, N_{TX} , from the N_TX field of the TXVECTOR. Produce the PLCP preamble training fields for each of the N_{TX} transmit chains based on the FORMAT, NUM_EXTEN_SS, CH_BANDWIDTH, and MCS parameters of the TXVECTOR. The format and relative placement of the PLCP preamble training fields vary depending on the frame format being used, as indicated by these parameters. Apply cyclic shifts. Determine spatial mapping to be used for HT-STF and HT-LTFs in HT-mixed format frame and HT-GF-STF and HT-LTFs in HT-greenfield format frame from the EXPANSION_MAT parameter of the TXVECTOR. Refer to 20.3.9 for details.
- b) Construct the PLCP preamble SIGNAL fields from the appropriate fields of the TXVECTOR by adding tail bits, applying convolutional coding, formatting into one or more OFDM symbols, applying cyclic shifts, applying spatial processing, calculating an inverse Fourier transform for each OFDM symbol and transmit chain, and prepending a cyclic prefix or GI to each OFDM symbol in each transmit chain. The number and placement of the PLCP preamble SIGNAL fields depend on the frame format being used. Refer to 20.3.9.3.5, 20.3.9.4.3, and 20.3.9.5.3.
- c) Concatenate the PLCP preamble training and SIGNAL fields for each transmit chain one field after another, in the appropriate order, as described in 20.3.2 and 20.3.7.

(Source: <https://web.archive.org/web/20190220214328/http://luci.subsignal.org/~jow/802.11n-2009.pdf>)

44. The accused products include wherein the training structure of each frame includes a predetermined signal transmission matrix at a respective sub-channel, each training structure adjusted to have a substantially constant amplitude in a time domain, and the cyclic prefixes are further inserted within the training symbol, and wherein the cyclic prefixes within the training symbol are longer than the cyclic prefixes among the data symbols, thereby countering an extended channel impulse response and improving synchronization performance. For example, a space time matrix is part of the data symbols and the training symbols in the transmission data. This data is transmitted over different antennas. The WiFi standards use guard intervals while transmitting frames to help the synchronization of frames at the receiver end. These guard intervals are of different lengths for the preamble and data symbols. The

screenshots below show the Guard interval in the Long Training Field is 1.6 micro seconds, and the data field uses a Short guard interval of 0.4 micro seconds, so the cyclic prefix for the training symbols is longer than the cyclic prefix for data symbols. The training symbols (L-STF, HT-STF fields) in the 802.11n preamble have a constant amplitude in the time domain.

- p) Map each of the complex numbers in each of the N_{ST} subcarriers in each of the OFDM symbols in each of the N_{STS} space-time streams to the N_{TX} transmit chain inputs. For direct-mapped operation, $N_{TX} = N_{STS}$, and there is a one-to-one correspondence between space-time streams and transmit chains. In this case, the OFDM symbols associated with each space-time stream are also associated with the corresponding transmit chain. Otherwise, a spatial mapping matrix associated with each OFDM subcarrier, as indicated by the EXPANSION_MAT parameter of the TXVECTOR, is used to perform a linear transformation on the vector of N_{STS} complex numbers associated with each subcarrier in each OFDM symbol. This spatial mapping matrix maps the vector of N_{STS} complex numbers in each subcarrier into a vector of N_{TX} complex numbers in each subcarrier. The sequence of N_{ST} complex numbers associated with each transmit chain (where each of the N_{ST} complex numbers is taken from the same position in the N_{TX} vector of complex numbers across the N_{ST} subcarriers associated with an OFDM symbol) constitutes an OFDM symbol associated with the corresponding transmit chain. For details, see 20.3.11.10. Spatial mapping matrices may include cyclic shifts, as described in 20.3.11.10.1.

(Source: <https://web.archive.org/web/20190220214328/http://luci.subsignal.org/~jow/802.11n-2009.pdf>)

T_{DFT} : IDFT/DFT period	3.2 μ s	3.2 μ s	3.2 μ s
T_{GI} : Guard interval duration	0.8 μ s = $T_{DFT}/4$	0.8 μ s	0.8 μ s
T_{GI2} : Double guard interval	1.6 μ s	1.6 μ s	1.6 μ s
T_{GIS} : Short guard interval duration	N/A	0.4 μ s = $T_{DFT}/8$	0.4 μ s See NOTE 2
T_{L-STF} : Non-HT short training sequence duration	8 μ s = $10 \times T_{DFT}/4$	8 μ s	8 μ s
$T_{HT-GF-STF}$: HT-greenfield short training field duration	N/A	8 μ s = $10 \times T_{DFT}/4$	8 μ s See NOTE 2
T_{L-LTF} : Non-HT long training field duration	8 μ s = $2 \times T_{DFT} + T_{GI2}$	8 μ s	8 μ s
T_{SYM} : Symbol interval	4 μ s = $T_{DFT} + T_{GI}$	4 μ s	4 μ s
T_{SYMS} : Short GI symbol interval	N/A	3.6 μ s = $T_{DFT} + T_{GIS}$	3.6 μ s See NOTE 2

(Source: <https://web.archive.org/web/20190220214328/http://luci.subsignal.org/~jow/802.11n-2009.pdf>)

STBC	2	Set to a nonzero number, to indicate the difference between the number of space-time streams (N_{STS}) and the number of spatial streams (N_{SS}) indicated by the MCS. Set to 00 to indicate no STBC ($N_{STS} = N_{SS}$). See NOTE 1.
FEC coding	1	Set to 1 for LDPC. Set to 0 for BCC.
Short GI	1	Set to 1 to indicate that the short GI is used after the HT training. Set to 0 otherwise.

(Source: <https://web.archive.org/web/20190220214328/http://luci.subsignal.org/~jow/802.11n-2009.pdf>)

20.3.11.10.5 Transmission with a short GI

Short GI is used in the data field of the packet when the Short GI field in the HT-SIG is set to 1. When it is used, the same formula for the formation of the signal shall be used as in 20.3.11.10.2, 20.3.11.10.3, and 20.3.11.10.4, with T_{GI} replaced by T_{GIS} and T_{SYM} replaced by T_{SYMS} .

(Source: <https://web.archive.org/web/20190220214328/http://luci.subsignal.org/~jow/802.11n-2009.pdf>)

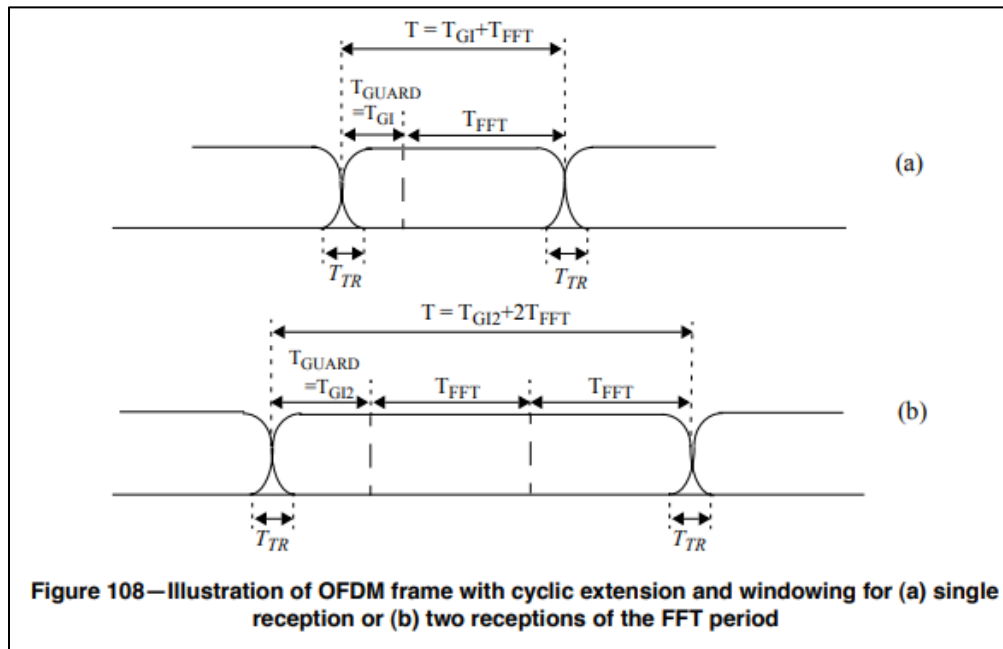

(Source:

<https://web.archive.org/web/20181225052447/http://www.ahltek.com/WhitePaperspdf/802.11-20%20specs/802.11a-1999.pdf>)

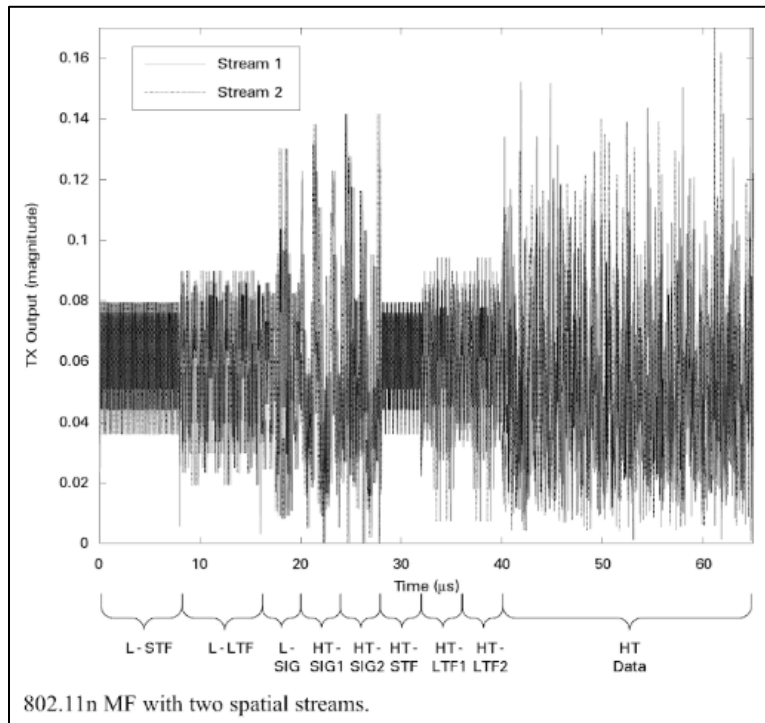

(Source: Next Generation Wireless LANs: 802.11n and 802.11ac, Perahia, Eldad and Stacey, Robert)

45. Qualcomm has directly infringed at least through its making and use of the accused products through its own testing of the accused products, and through joint infringement with its affiliates, with its subsidiaries, with carriers, with retailers and other sales entities, with its business partners, with certification organizations, with testing organizations, with other agents of Qualcomm, and/or with its customers and end-users, at least making and using the claimed apparatus. Such acts of infringement include directing or controlling other persons to engage in conduct satisfying one or more elements of the asserted claims, deriving a financial or other benefit from doing so. Qualcomm's direction or control of its affiliates and end-users

includes regularly contracting with those affiliates and end-users. Also, as explained further below, Qualcomm took active steps and advised or directed customers and end-users to make and/or use the accused products in an infringing manner.

46. Qualcomm has had knowledge of the ‘304 Patent at least as of April 2, 2008, when the ‘304 Patent’s published application, U.S. Patent Application Publication No. 2002/0181390, was used by the examiner as the primary reference in obviousness rejections of sixteen claims in a non-final rejection during the prosecution of U.S. Patent Application No. 10/896,277, the Examiner stating, for example, that “Mody discloses an invention for ‘estimating channel parameters in multiple-in, multiple-output (MIMO) system.” That application issued as U.S. Patent No. 8,000,221, titled “Adaptive Pilot Insertion For A MIMO-OFDM System” and was assigned to Qualcomm Incorporated. On June 16, 2010, Qualcomm submitted the ‘304 Patent itself in an Information Disclosure Statement. Qualcomm employees Jay Rodney Walton and Mark S. Wallace, who are listed as inventors on U.S. Patent No. 8,000,221, and others involved in the prosecution of the patent, have had knowledge of the ‘304 Patent at least as of April 2, 2008.

47. Qualcomm has cited the ‘304 Patent during prosecution of at least twenty-eight of its patents. For example, Qualcomm has had knowledge of the ‘304 Patent at least as of September 27, 2013, when it cited the ‘304 Patent in an Information Disclosure Statement during the prosecution of U.S. Patent Application No. 13/014,578. That application issued as U.S. Patent No. 9,031,122, titled “Reducing Phase Errors On A Communication Device” and was assigned to Qualcomm Inc. Qualcomm employee Didier Johannes Richard Van Nee, who is listed as an inventor on U.S. Patent No. 9,031,122, and others involved in the prosecution of the patent, have had knowledge of the ‘304 Patent at least as of September 27, 2013.

48. Likewise, Qualcomm has had knowledge of the ‘304 Patent at least as of August 26, 2015, when it cited the ‘304 Patent in an Information Disclosure Statement during the prosecution of U.S. Patent Application No. 14/836,620. That application issued as U.S. Patent No. 9,967,005, titled “Pilots For MIMO Communication Systems” and was assigned to Qualcomm Inc. Qualcomm employees John Ketchum, Mark Wallace, Rodney Walton, and Steven Howard, who are listed as inventors on U.S. Patent No. 9,967,005, and others involved in the prosecution of the patent, have had knowledge of the ‘304 Patent at least as of August 26, 2015.

49. Qualcomm has had actual knowledge of the ‘304 Patent at least as of the date when it was notified of the filing of this action. By the time of trial, Qualcomm will have known and intended (since receiving such notice) that its continued actions would infringe and actively induce and contribute to the infringement of one or more claims of the ‘304 Patent.

50. Qualcomm has also indirectly and willfully infringed, and continues to indirectly and willfully infringe, the ‘304 Patent, as explained further below in the “Additional Allegations Regarding Infringement and Personal Jurisdiction” section.

51. American Patents has been damaged as a result of the infringing conduct by Qualcomm alleged above. Thus, Qualcomm is liable to American Patents in an amount that adequately compensates it for such infringements, which, by law, cannot be less than a reasonable royalty, together with interest and costs as fixed by this Court under 35 U.S.C. § 284.

52. American Patents has neither made nor sold unmarked articles that practice the ‘304 Patent, and is entitled to collect pre-filing damages for the full period allowed by law for infringement of the ‘304 Patent.

COUNT III

INFRINGEMENT OF U.S. PATENT NO. 7,706,458

53. On April 27, 2010, United States Patent No. 7,706,458 (“the ‘458 Patent”) was duly and legally issued by the United States Patent and Trademark Office for an invention entitled “Time And Frequency Synchronization In Multi-Input, Multi-Output (MIMO) Systems.”

54. American Patents is the owner of the ‘458 Patent, with all substantive rights in and to that patent, including the sole and exclusive right to prosecute this action and enforce the ‘458 Patent against infringers, and to collect damages for all relevant times.

55. Qualcomm made, had made, used, imported, provided, supplied, distributed, sold, and/or offered for sale products and/or systems including, for example, its Qualcomm FastConnect 7800 (with 4x4 MIMO), Qualcomm Snapdragon 888 5G Mobile Platform (with 2x2 MIMO), and Qualcomm QCA9379 (with 2x2 MIMO) families of products that include 802.11n and above and/or LTE capabilities (“accused products”):

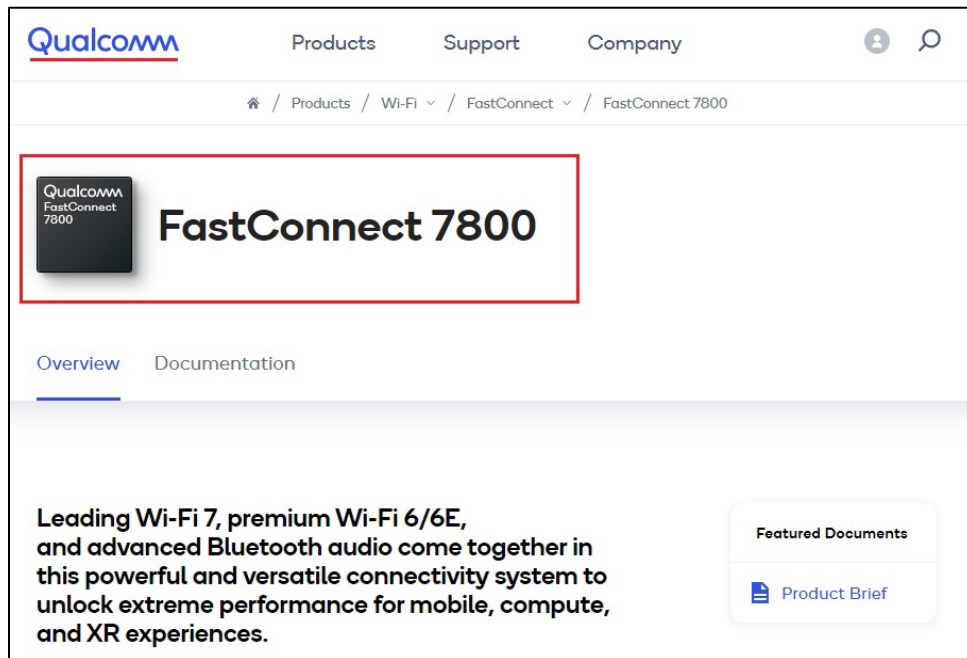

(Source : <https://www.qualcomm.com/products/fastconnect-7800>)

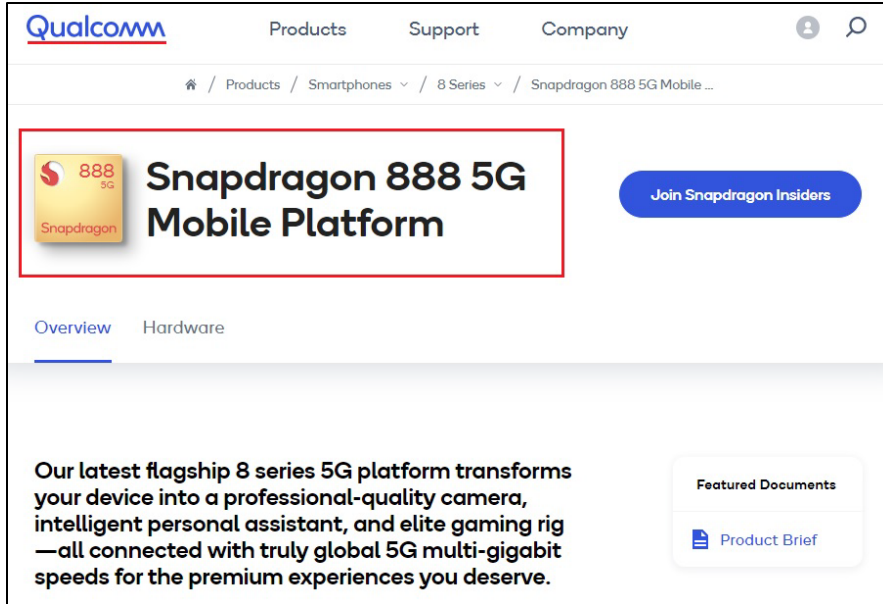

(Source : <https://www.qualcomm.com/products/snapdragon-888-5g-mobile-platform>)

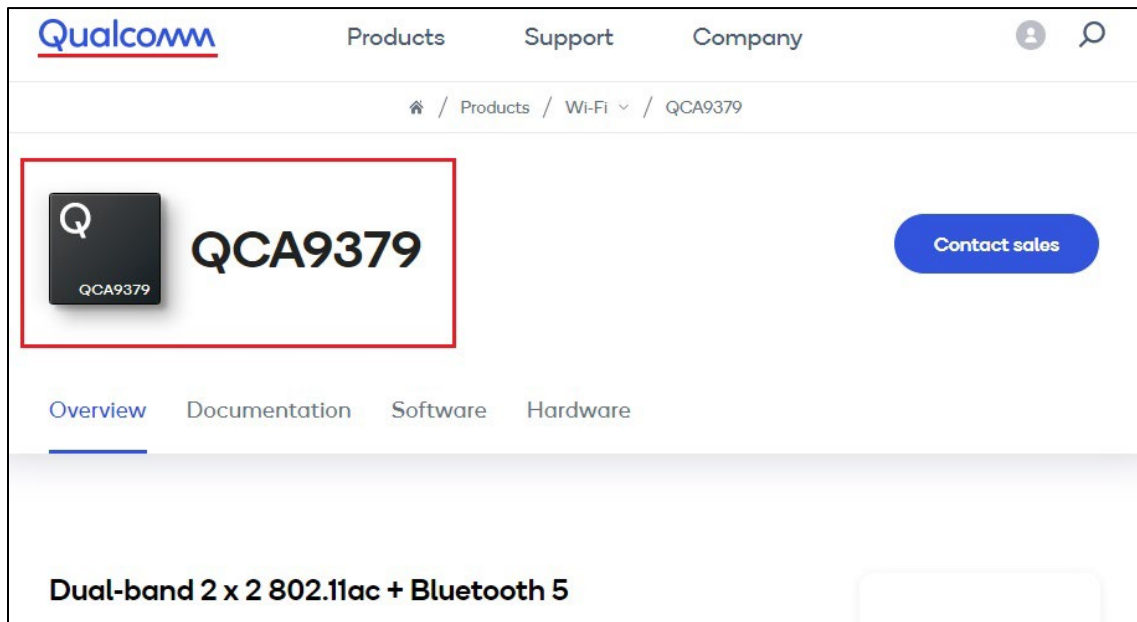

(Source : <https://www.qualcomm.com/products/technology/wi-fi/qca9379>)

Specifications	
Process Technology	14nm
<u>Wi-Fi Standards</u>	<u>Wi-Fi 7, Wi-Fi 6E, Wi-Fi 6 (802.11ax), 802.11ac wave 2, 802.11a/b/g, 802.11n</u>
Wi-Fi Spectral Bands	2.4GHz, 5GHz, 6GHz
Peak Speed	5.8 Gbps*
<u>Wi-Fi Features</u>	<u>4-Stream Dual Band Simultaneous in the High Bands,</u> 4K QAM, Multi-Link Operation (MLO), 320MHz (single channel, or 160 + 160), 8x8 Sounding, <u>MU-MIMO (Uplink and Downlink)</u> , OFDMA (Uplink and Downlink), Target Wake Time (TWT), Passpoint, Wi-Fi Aware R3, Wi-Fi Location, Wi-Fi Optimized Connectivity, Wi-Fi QoS Management, TDLS, Miracast, Voice-Enterprise

(Source : <https://www.qualcomm.com/media/documents/files/mwc-2022-qualcomm-fastconnect-7800-product-brief.pdf>)

Wi-Fi & Bluetooth
<ul style="list-style-type: none"> FastConnect 6900 System <ul style="list-style-type: none"> Wi-Fi Standards: Wi-Fi 6E, Wi-Fi 6 (802.11ax), Wi-Fi 5 (802.11ac), 802.11a/b/g/n Wi-Fi Spectral Bands: 2.4 GHz, 5 GHz, 6 GHz Peak speed: 3.6 Gbps Channel Utilization: 20/40/80/160 MHz 8-stream sounding (for 8x8 MU-MIMO) MIMO Configuration: 2x2 (2-stream) MU-MIMO (Uplink & Downlink) 4K QAM OFDMA (Uplink & Downlink) Dual-band simultaneous (2x2 + 2x2) Wi-Fi Security: WPA3-Enterprise, WPA3-Enhanced Open, WPA3 Easy Connect, WPA3-Personal

(Source :

https://www.qualcomm.com/system/files/document/files/prod_brief_qcom_sd888_5g_1_0.pdf)

Wi-Fi	Standards: 802.11ac Wave 2, 802.11a/b/g, 802.11n
	Wi-Fi Spectral Bands: 2.4 GHz, 5 GHz
	Peak Speed: 620 Mbps
	Channel Utilization: 20/40/80 MHz
	MIMO Configuration: 2x2 (2-stream)
	Wi-Fi Features: MU-MIMO, TxBF

(Source : <https://www.qualcomm.com/products/technology/wi-fi/qca9379>)

56. By doing so, Qualcomm has directly infringed (literally and/or under the doctrine of equivalents) at least Claim 1 of the '458 Patent. Qualcomm's infringement in this regard is ongoing.

57. Qualcomm has infringed the '458 Patent by making, having made, using, importing, providing, supplying, distributing, selling or offering for sale products including an apparatus for synchronizing a communication system. For example, the accused products can act and have acted as a receiver in an apparatus for synchronizing a communication system. An 802.11 n/ac compliant WiFi access point that is communicating with an accused product can be part of the apparatus, acting as a transmitter. The accused products support IEEE 802.11 n/ac standards and MIMO technology. The IEEE 802.11ac standard is backwards compatible with the 802.11n standard. If a device such as an accused product complies with IEEE 802.11ac, it also complies with IEEE 802.11n and all prior versions of the WiFi standards (802.11 a/b/g/n). According to the 802.11a standard, the physical layer services include an OFDM system.

According to the IEEE 802.11n standard, all Protocol Data Unit (PPDU) frame formats have training fields and signaling fields which would help in synchronizing the communication system.

The introduction of 802.11ac expands the compatibility matrix in the 5 GHz band from two concurrently operating technologies to three, and the compatibility considerations in a broadcast network medium extend not only to intended receivers but to any receiver. Table 3-4 describes the compatibility between transmitters of frames and their intended receivers. That is, if a transmitter of the type in the left column sends a frame directed to a receiver of the type in any of the other three columns, what will the result be? One of the major methods used to support coexistence is backward compatibility. When built, 802.11ac devices will also incorporate 802.11a and 802.11n data rates, and thus will be able to send to older peers at older data rates.

(Source: 802.11ac: A Survival Guide: Wi-Fi at Gigabit and Beyond, Gast, Matthew S.)

Table 3-5. Compatibility between transmitters and listening devices

Transmitter type	802.11a listener	802.11n listener	802.11ac listener
802.11a	Designed operation	802.11n devices listen to 802.11a frames and defer medium access to avoid collisions	802.11ac devices listen to 802.11a frames and defer medium access to avoid collisions
802.11n	802.11n greenfield frames require RTS/CTS or CTS-to-self protection; 802.11n mixed-mode frames require no special protection	Designed operation	802.11ac devices listen to 802.11n frames and defer medium access to avoid collisions
802.11ac	802.11ac uses a compatible physical preamble, allowing 802.11a devices to read the medium as busy and avoid collisions	802.11ac uses a compatible preamble, allowing 802.11n devices to read the medium as busy and avoid collisions	Designed operation

(Source: 802.11ac: A Survival Guide: Wi-Fi at Gigabit and Beyond, Gast, Matthew S.)

17.1.1 Scope

This subclause describes the PHY services provided to the IEEE 802.11 wireless LAN MAC by the 5 GHz (bands) OFDM system. The OFDM PHY layer consists of two protocol functions, as follows:

- a) A PHY convergence function, which adapts the capabilities of the physical medium dependent (PMD) system to the PHY service. This function is supported by the physical layer convergence procedure (PLCP), which defines a method of mapping the IEEE 802.11 PHY sublayer service data units (PSDU) into a framing format suitable for sending and receiving user data and management information between two or more stations using the associated PMD system.
- b) A PMD system whose function defines the characteristics and method of transmitting and receiving data through a wireless medium between two or more stations, each using the OFDM system.

(Source: https://standards.ieee.org/standard/802_11a-1999.html)

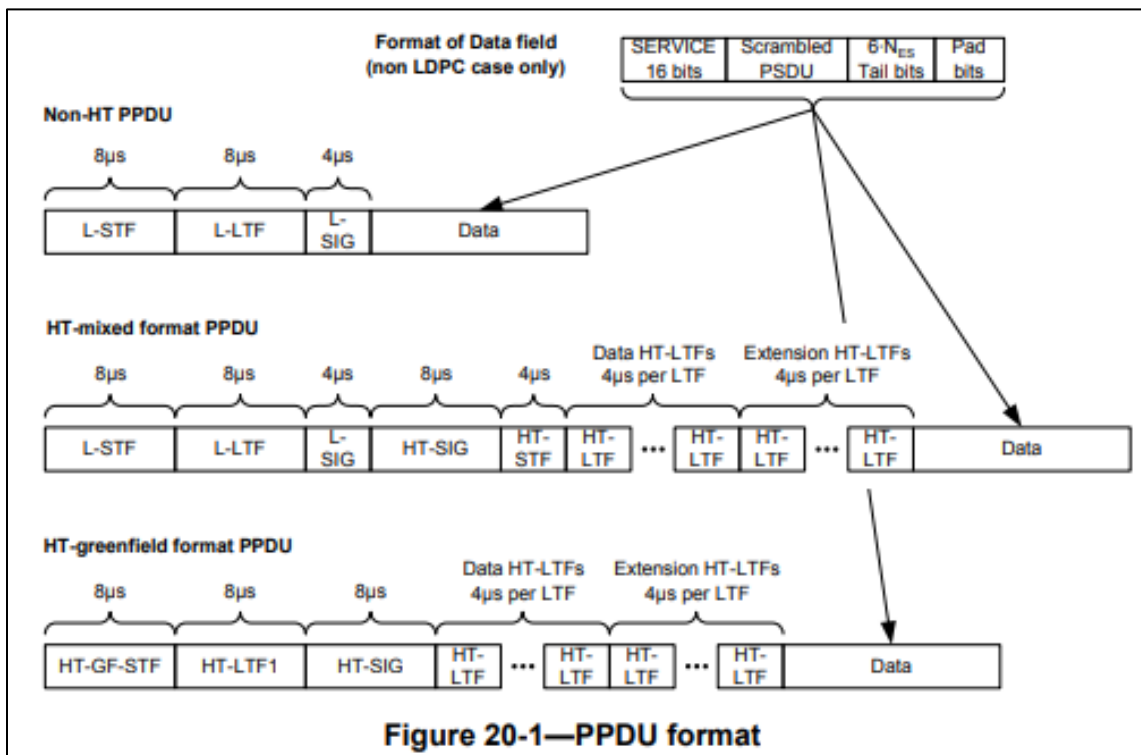

(Source: <https://web.archive.org/web/20190220214328/http://luci.subsignal.org/~jow/802.11n-2009.pdf>)

The fields of the VHT PPDU format are summarized in Table 22-4.

Table 22-4—Fields of the VHT PPDU

Field	Description
L-STF	Non-HT Short Training field
L-LTF	Non-HT Long Training field
L-SIG	Non-HT SIGNAL field
VHT-SIG-A	VHT Signal A field
VHT-STF	VHT Short Training field
VHT-LTF	VHT Long Training field
VHT-SIG-B	VHT Signal B field
Data	The Data field carries the PSDU(s)

(Source: <https://ieeexplore.ieee.org/document/7797535/>)

58. The accused products include a number (Q) of Orthogonal Frequency Division Multiplexing (OFDM) modulators, each OFDM modulator producing a frame having at least one inserted symbol, a plurality of data symbols, and cyclic prefixes. According to the IEEE 802.11n standard, a transmitter block contains different functional blocks which include, but are not limited to, constellation mappers, IDFT stage, and Guard interval insertion. Constellation mappers map the bits and the constellation points for different modulation schemes like QPSK, BPSK, 16-QAM, 64-QAM. After modulating the signal, it is converted into time domain and is transmitted as frames of data. These transmitted frames include training field bits, signal bits, cyclic prefixes and data bits. Alternatively, on request from an accused product, an 802.11 n/ac compliant WiFi access point can act as a transmitter that includes a number (Q) of OFDM modulators, each OFDM modulator producing a frame having at least one inserted symbol, a plurality of data symbols, and cyclic prefixes.

20.3.3 Transmitter block diagram

HT-mixed format and HT-greenfield format transmissions can be generated using a transmitter consisting of the following blocks:

- a) *Scrambler* scrambles the data to reduce the probability of long sequences of zeros or ones; see 20.3.11.2.
- b) *Encoder parser*, if BCC encoding is to be used, demultiplexes the scrambled bits among N_{ES} (number of BCC encoders for the Data field) BCC encoders, in a round robin manner.
- c) *FEC encoders* encode the data to enable error correction. An FEC encoder may include a binary convolutional encoder followed by a puncturing device, or it may include an LDPC encoder.
- d) *Stream parser* divides the outputs of the encoders into blocks that are sent to different interleaver and mapping devices. The sequence of the bits sent to an interleaver is called a *spatial stream*.
- e) *Interleaver* interleaves the bits of each spatial stream (changes order of bits) to prevent long sequences of adjacent noisy bits from entering the BCC decoder. Interleaving is applied only when BCC encoding is used.
- f) *Constellation mapper* maps the sequence of bits in each spatial stream to constellation points (complex numbers).
- g) *STBC encoder* spreads constellation points from N_{SS} spatial streams into N_{STS} space-time streams using a space-time block code. STBC is used only when $N_{SS} < N_{STS}$; see 20.3.11.8.1.
- h) *Spatial mapper* maps space-time streams to transmit chains. This may include one of the following:
 - 1) *Direct mapping*: Constellation points from each space-time stream are mapped directly onto the transmit chains (one-to-one mapping).

(Source: <https://web.archive.org/web/20190220214328/http://luci.subsignal.org/~jow/802.11n-2009.pdf>)

The encoding process is composed of the steps described below. The following overview is intended to facilitate an understanding of the details of the convergence procedure:

- a) Determine the number of transmit chains, N_{TX} , from the N_TX field of the TXVECTOR. Produce the PLCP preamble training fields for each of the N_{TX} transmit chains based on the FORMAT, NUM_EXTEN_SS, CH_BANDWIDTH, and MCS parameters of the TXVECTOR. The format and relative placement of the PLCP preamble training fields vary depending on the frame format being used, as indicated by these parameters. Apply cyclic shifts. Determine spatial mapping to be used for HT-STF and HT-LTFs in HT-mixed format frame and HT-GF-STF and HT-LTFs in HT-greenfield format frame from the EXPANSION_MAT parameter of the TXVECTOR. Refer to 20.3.9 for details.
- b) Construct the PLCP preamble SIGNAL fields from the appropriate fields of the TXVECTOR by adding tail bits, applying convolutional coding, formatting into one or more OFDM symbols, applying cyclic shifts, applying spatial processing, calculating an inverse Fourier transform for each OFDM symbol and transmit chain, and prepending a cyclic prefix or GI to each OFDM symbol in each transmit chain. The number and placement of the PLCP preamble SIGNAL fields depend on the frame format being used. Refer to 20.3.9.3.5, 20.3.9.4.3, and 20.3.9.5.3.
- c) Concatenate the PLCP preamble training and SIGNAL fields for each transmit chain one field after another, in the appropriate order, as described in 20.3.2 and 20.3.7.

(Source: <https://web.archive.org/web/20190220214328/http://luci.subsignal.org/~jow/802.11n-2009.pdf>)

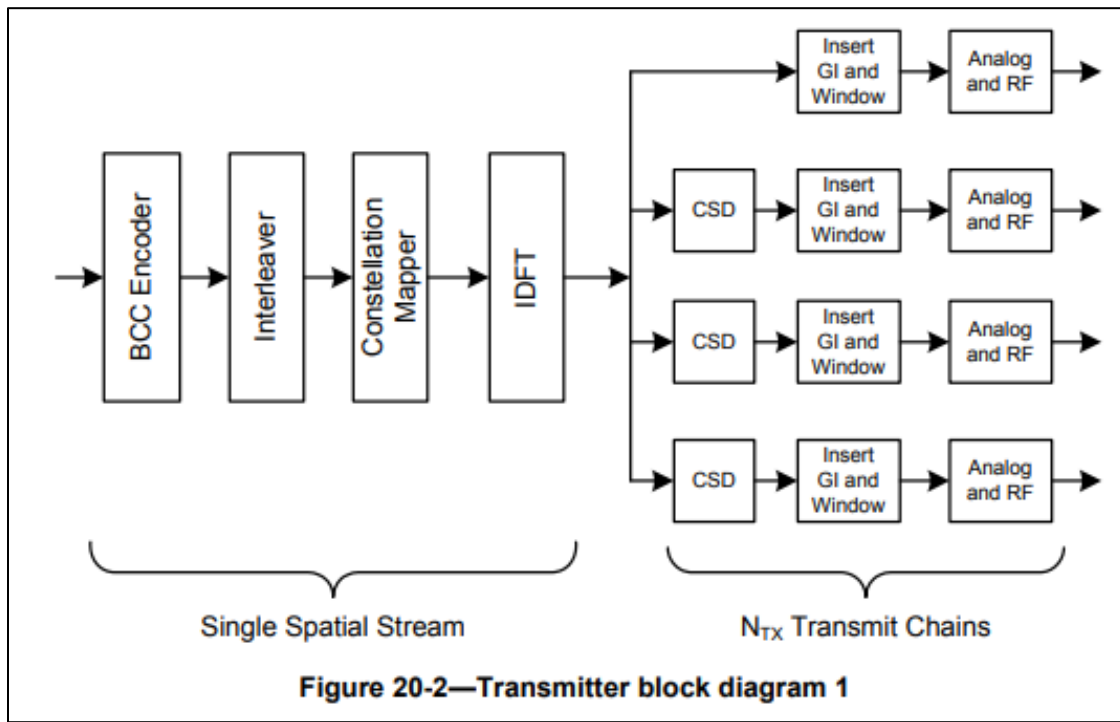

(Source: <https://web.archive.org/web/20190220214328/http://luci.subsignal.org/~jow/802.11n-2009.pdf>)

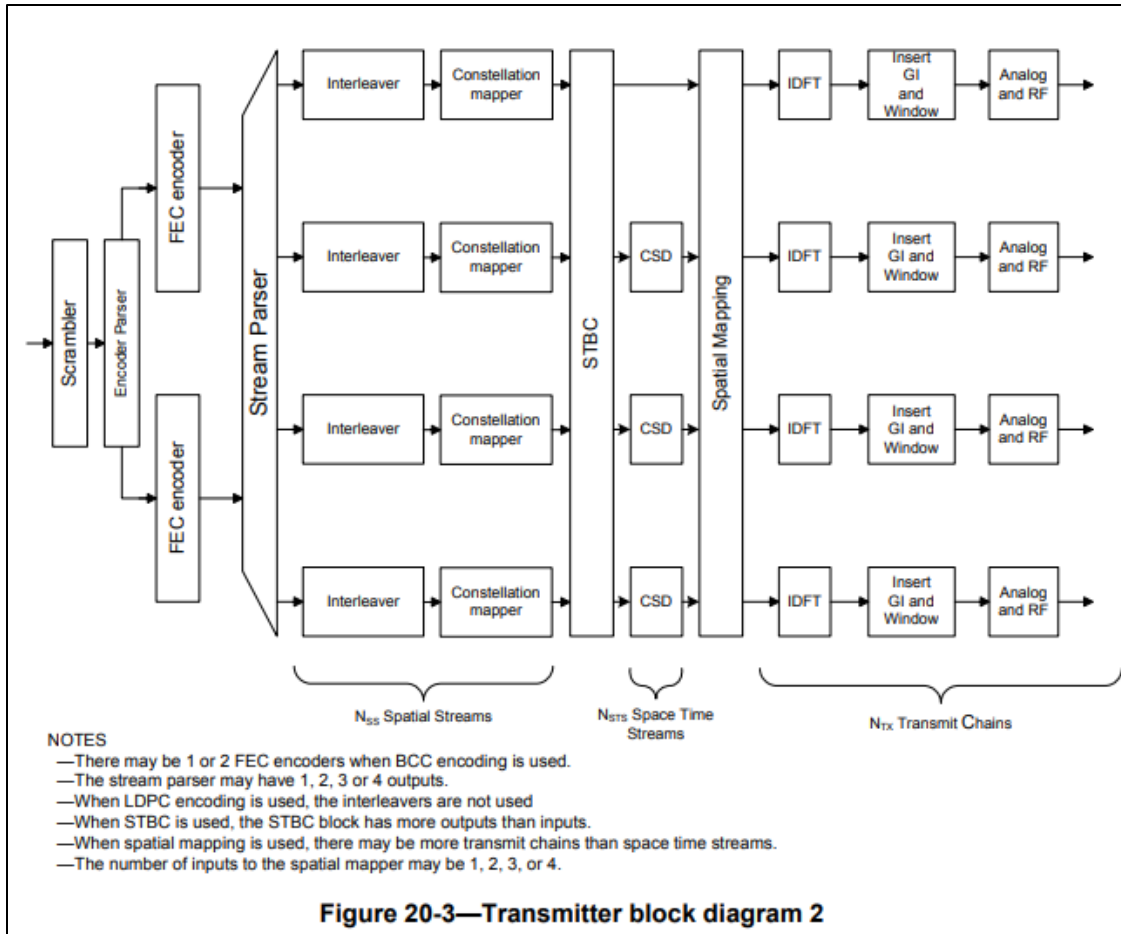

(Source: <https://web.archive.org/web/20190220214328/http://luci.subsignal.org/~jow/802.11n-2009.pdf><http://luci.subsignal.org/~jow/802.11n-2009.pdf>)

59. The accused products include Q transmitting antennas, each transmitting antenna connected to a respective OFDM modulator, the transmitting antennas configured to transmit a respective frame over a channel. The accused products support MIMO and comply with IEEE 802.11 a/b/g/n/ac standards. The transmitting antennas transmit multiple OFDM frames over a channel. The transmitting antennas are connected to OFDM modulators to transmit the OFDM frames over a channel. Alternatively, on request from an accused product, a WiFi access point acts as a device that includes Q transmitting antennas, each transmitting antenna connected to a

respective OFDM modulator, the transmitting antennas configured to transmit a respective frame over a channel.

Specifications	
Process Technology	14nm
<u>Wi-Fi Standards</u>	<u>Wi-Fi 7, Wi-Fi 6E, Wi-Fi 6 (802.11ax), 802.11ac wave 2, 802.11a/b/g, 802.11n</u>
Wi-Fi Spectral Bands	2.4GHz, 5GHz, 6GHz
Peak Speed	5.8 Gbps*
<u>Wi-Fi Features</u>	<u>4-Stream Dual Band Simultaneous in the High Bands,</u> 4K QAM, Multi-Link Operation (MLO), 320MHz (single channel, or 160 + 160), 8x8 Sounding, <u>MU-MIMO (Uplink and Downlink)</u> , OFDMA (Uplink and Downlink), Target Wake Time (TWT), Passpoint, Wi-Fi Aware R3, Wi-Fi Location, Wi-Fi Optimized Connectivity, Wi-Fi QoS Management, TDLS, Miracast, Voice-Enterprise

(Source : <https://www.qualcomm.com/media/documents/files/mwc-2022-qualcomm-fastconnect-7800-product-brief.pdf>)

Wi-Fi & Bluetooth

- FastConnect 6900 System
 - Wi-Fi Standards: Wi-Fi 6E, Wi-Fi 6 (802.11ax), Wi-Fi 5 (802.11ac), 802.11a/b/a/n
 - Wi-Fi Spectral Bands: 2.4 GHz, 5 GHz, 6 GHz
 - Peak speed: 3.6 Gbps
 - Channel Utilization: 20/40/80/160 MHz
 - 8-stream sounding (for 8x8 MU-MIMO)
 - MIMO Configuration: 2x2 (2-stream)
 - MU-MIMO (Uplink & Downlink)
 - 4K QAM
 - OFDMA (Uplink & Downlink)
 - Dual-band simultaneous (2x2 + 2x2)
 - Wi-Fi Security: WPA3-Enterprise, WPA3-Enhanced Open, WPA3 Easy Connect, WPA3-Personal

(Source :

https://www.qualcomm.com/system/files/document/files/prod_brief_qcom_sd888_5g_1_0.pdf)

Wi-Fi	Standards: 802.11ac Wave 2, 802.11a/b/g, 802.11n
	Wi-Fi Spectral Bands: 2.4 GHz, 5 GHz
	Peak Speed: 620 Mbps
	Channel Utilization: 20/40/80 MHz
	MIMO Configuration: 2x2 (2-stream)
	Wi-Fi Features: MU-MIMO, TxBF

(Source : <https://www.qualcomm.com/products/technology/wi-fi/qca9379>)

20.3.4 Overview of the PPDU encoding process

The encoding process is composed of the steps described below. The following overview is intended to facilitate an understanding of the details of the convergence procedure:

- a) Determine the number of transmit chains, N_{TX} , from the N_TX field of the TXVECTOR. Produce the PLCP preamble training fields for each of the N_{TX} transmit chains based on the FORMAT, NUM_EXTEN_SS, CH_BANDWIDTH, and MCS parameters of the TXVECTOR. The format and relative placement of the PLCP preamble training fields vary depending on the frame format being used, as indicated by these parameters. Apply cyclic shifts. Determine spatial mapping to be used for HT-STF and HT-LTFs in HT-mixed format frame and HT-GF-STF and HT-LTFs in HT-greenfield format frame from the EXPANSION_MAT parameter of the TXVECTOR. Refer to 20.3.9 for details.
- b) Construct the PLCP preamble SIGNAL fields from the appropriate fields of the TXVECTOR by adding tail bits, applying convolutional coding, formatting into one or more OFDM symbols, applying cyclic shifts, applying spatial processing, calculating an inverse Fourier transform for each OFDM symbol and transmit chain, and prepending a cyclic prefix or GI to each OFDM symbol in each transmit chain. The number and placement of the PLCP preamble SIGNAL fields depend on the frame format being used. Refer to 20.3.9.3.5, 20.3.9.4.3, and 20.3.9.5.3.
- c) Concatenate the PLCP preamble training and SIGNAL fields for each transmit chain one field after another, in the appropriate order, as described in 20.3.2 and 20.3.7.

(Source: <https://web.archive.org/web/20190220214328/http://luci.subsignal.org/~jow/802.11n-2009.pdf>)

60. The accused products include a number (L) of receiving antennas for receiving the transmitted frames. For example, the accused products support MIMO and comply with 802.11 a/b/g/n/ac WiFi standards. The receiving antennas receive the transmitted frames.

Specifications	
Process Technology	14nm
<u>Wi-Fi Standards</u>	<u>Wi-Fi 7, Wi-Fi 6E, Wi-Fi 6 (802.11ax), 802.11ac wave 2, 802.11a/b/g, 802.11n</u>
Wi-Fi Spectral Bands	2.4GHz, 5GHz, 6GHz
Peak Speed	5.8 Gbps*
<u>Wi-Fi Features</u>	<u>4-Stream Dual Band Simultaneous in the High Bands,</u> 4K QAM, Multi-Link Operation (MLO), 320MHz (single channel, or 160 + 160), 8x8 Sounding, <u>MU-MIMO (Uplink and Downlink)</u> , OFDMA (Uplink and Downlink), Target Wake Time (TWT), Passpoint, Wi-Fi Aware R3, Wi-Fi Location, Wi-Fi Optimized Connectivity, Wi-Fi QoS Management, TDLS, Miracast, Voice-Enterprise

(Source : <https://www.qualcomm.com/media/documents/files/mwc-2022-qualcomm-fastconnect-7800-product-brief.pdf>)

Wi-Fi & Bluetooth
<ul style="list-style-type: none"> FastConnect 6900 System <ul style="list-style-type: none"> Wi-Fi Standards: Wi-Fi 6E, Wi-Fi 6 (802.11ax), Wi-Fi 5 (802.11ac), 802.11a/b/g/n Wi-Fi Spectral Bands: 2.4 GHz, 5 GHz, 6 GHz Peak speed: 3.6 Gbps Channel Utilization: 20/40/80/160 MHz 8-stream sounding (for 8x8 MU-MIMO) MIMO Configuration: 2x2 (2-stream) MU-MIMO (Uplink & Downlink) 4K QAM OFDMA (Uplink & Downlink) Dual-band simultaneous (2x2 + 2x2) Wi-Fi Security: WPA3-Enterprise, WPA3-Enhanced Open, WPA3 Easy Connect, WPA3-Personal

(Source :

https://www.qualcomm.com/system/files/document/files/prod_brief_qcom_sd888_5g_1_0.pdf)

Wi-Fi	Standards: 802.11ac Wave 2, 802.11a/b/g, 802.11n
	Wi-Fi Spectral Bands: 2.4 GHz, 5 GHz
	Peak Speed: 620 Mbps
	Channel Utilization: 20/40/80 MHz
	MIMO Configuration: 2x2 (2-stream)
	Wi-Fi Features: MU-MIMO, TxBF

(Source : <https://www.qualcomm.com/products/technology/wi-fi/qca9379>)

61. The accused products include L OFDM demodulators, each OFDM demodulator corresponding to a respective receiving antenna, the L OFDM demodulators including a synchronization circuit that processes the received frame in order to synchronize the received frame in both time domain and frequency domain. For example, there is a demodulator block for performing demodulation on the received frames. Further, synchronizing the received frame in time and frequency domains occurs. In an OFDM transmitter section, a modulated signal is converted into time domain and is transmitted as multiple frames of data. The functional blocks present at the receiver end processes the received data, converts the data into frequency domain, and performs demodulation. Various signal bits present in the transmitted frames' preamble helps in demodulating the signal. A demodulator block is present at the receiver to perform demodulation. Different fields of data like training bits, cyclic prefixes and other signal bits present in the received frame helps in synchronizing the frame in both time and frequency

domain. There is a synchronization circuit which processes the received frame and synchronizes them in both time and frequency domain.

20.3.1 Introduction

A convergence procedure, in which PSDUs are converted to and from PPDU, is provided for the HT PHY in 20.3. During transmission, the PSDU is processed (i.e., scrambled and coded) and appended to the PLCP preamble to create the PPDU. At the receiver, the PLCP preamble is processed to aid in demodulation and delivery of the PSDU.

Two preamble formats are defined. For HT-mixed format operation, the preamble has a non-HT portion and an HT portion. The non-HT portion of the HT-mixed format preamble enables detection of the PPDU and acquisition of carrier frequency and timing by both HT STAs and STAs that are compliant with Clause 17 and/or Clause 19. The non-HT portion of the HT-mixed format preamble also consists of the SIGNAL field defined in Clause 17 and is thus decodable by STAs compliant with Clause 17 and Clause 19 as well as HT STAs.

(Source: <https://web.archive.org/web/20190220214328/http://luci.subsignal.org/~jow/802.11n-2009.pdf>)

3.244 receive chain: The physical entity that implements any necessary signal processing to provide the received signal to the digital baseband. Such signal processing includes filtering, amplification, down-conversion, and sampling.

3.245 sounding: The use of preamble training fields to measure the channel for purposes other than demodulation of the Data portion of the physical layer convergence procedure (PLCP) protocol data unit (PPDU) containing the training fields.

NOTE—These uses include calculation of transmit steering, calculation of recommended MCS, and calculation of calibration parameters.

(Source: <https://web.archive.org/web/20190220214328/http://luci.subsignal.org/~jow/802.11n-2009.pdf>)

The encoding process is composed of the steps described below. The following overview is intended to facilitate an understanding of the details of the convergence procedure:

- a) Determine the number of transmit chains, N_{TX} , from the N_TX field of the TXVECTOR. Produce the PLCP preamble training fields for each of the N_{TX} transmit chains based on the FORMAT, NUM_EXTEN_SS, CH_BANDWIDTH, and MCS parameters of the TXVECTOR. The format and relative placement of the PLCP preamble training fields vary depending on the frame format being used, as indicated by these parameters. Apply cyclic shifts. Determine spatial mapping to be used for HT-STF and HT-LTFs in HT-mixed format frame and HT-GF-STF and HT-LTFs in HT-greenfield format frame from the EXPANSION_MAT parameter of the TXVECTOR. Refer to 20.3.9 for details.
- b) Construct the PLCP preamble SIGNAL fields from the appropriate fields of the TXVECTOR by adding tail bits, applying convolutional coding, formatting into one or more OFDM symbols, applying cyclic shifts, applying spatial processing, calculating an inverse Fourier transform for each OFDM symbol and transmit chain, and prepending a cyclic prefix or GI to each OFDM symbol in each transmit chain. The number and placement of the PLCP preamble SIGNAL fields depend on the frame format being used. Refer to 20.3.9.3.5, 20.3.9.4.3, and 20.3.9.5.3.
- c) Concatenate the PLCP preamble training and SIGNAL fields for each transmit chain one field after another, in the appropriate order, as described in 20.3.2 and 20.3.7.

(Source: <https://web.archive.org/web/20190220214328/http://luci.subsignal.org/~jow/802.11n-2009.pdf>)

20.3.21.7.4 Transmitter modulation accuracy (EVM) test

The transmit modulation accuracy test shall be performed by instrumentation capable of converting the transmitted signals into a streams of complex samples at 40 Msample/s or more, with sufficient accuracy in terms of I/Q arm amplitude and phase balance, dc offsets, phase noise, and analog-to-digital quantization noise. Each transmit chain is connected directly through a cable to the setup input port. A possible embodiment of such a setup is converting the signals to a low intermediate frequency with a microwave synthesizer, sampling the signal with a digital oscilloscope, and decomposing it digitally into quadrature components. The sampled signal shall be processed in a manner similar to an actual receiver, according to the following steps, or an equivalent procedure:

- a) Detect the start of frame.
- b) Detect the transition from short sequences to channel estimation sequences, and establish fine timing (with one sample resolution).
- c) Estimate the coarse and fine frequency offsets.
- d) Derotate the frame according to estimated frequency offset.
- e) Estimate the complex channel response coefficients for each of the subcarriers and each of the transmit chains.
- f) For each of the data OFDM symbols, transform the symbol into subcarrier received values, estimate the phase from the pilot subcarriers in all spatial streams, derotate the subcarrier values according to estimated phase, group the results from all the receiver chains in each subcarrier to a vector, multiply the vector by a zero-forcing equalization matrix generated from the channel estimated during the channel estimation phase.
- g) For each data-carrying subcarrier in each spatial stream, find the closest constellation point and compute the Euclidean distance from it.
- h) Compute the average of the RMS of all errors in a frame. It is given by Equation (20-89).

(Source: <https://web.archive.org/web/20190220214328/http://luci.subsignal.org/~jow/802.11n-2009.pdf>)

62. The accused products include wherein each of the L OFDM demodulators comprises a pre-amplifier, a local oscillator, a mixer having a first input and a second input, the first input connected to an output of the pre-amplifier, the second input connected to an output of the local oscillator, an analog-to-digital converter (ADC) connected to an output of the mixer. The demodulating section at the receiver end includes a pre-amplifier, a local oscillator, a mixer, and an ADC. The received frames undergo filtering, amplification (pre-amplifier), down-conversion and sampling (ADC). There are respective functional blocks for performing these

functions. After transmitting the data, the data is received by a receiving antenna for further processing. To prevent the demodulator from demodulating the noise associated with the received signal, an RF front end circuit is implemented to increase the SNR of the demodulated signal. The RF front end circuit generally consists of amplifiers, local oscillator, filters and mixers. The output from the mixer is generally fed to an analog-to-digital converter (ADC). This RF front end circuit generally lies at the start of the demodulation process.

3.244 receive chain: The physical entity that implements any necessary signal processing to provide the received signal to the digital baseband. Such signal processing includes filtering, amplification, down-conversion, and sampling.

3.245 sounding: The use of preamble training fields to measure the channel for purposes other than demodulation of the Data portion of the physical layer convergence procedure (PLCP) protocol data unit (PPDU) containing the training fields.

NOTE—These uses include calculation of transmit steering, calculation of recommended MCS, and calculation of calibration parameters.

(Source: <https://web.archive.org/web/20190220214328/http://luci.subsignal.org/~jow/802.11n-2009.pdf>)

The technique to combat a low $\text{SNR}_{\text{demod_in}}$ is by adding a front end block, which processes (conditions) the received signal/AWGN/interference before admitting it to the demodulator. This processing can be done in several ways:

(Source: VLSI for Wireless Communication)

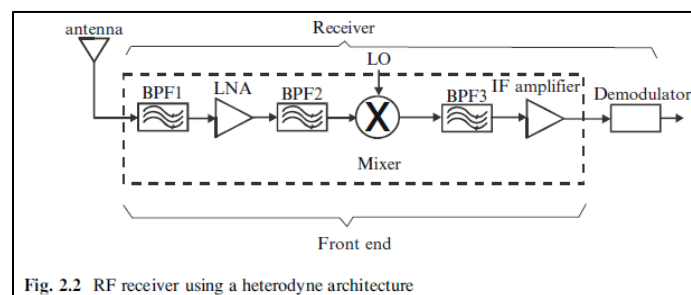

Fig. 2.2 RF receiver using a heterodyne architecture

(Source: VLSI for Wireless Communication)

2.4 Rest of Receiver Front End: Nonidealities and Design Parameters

Now that we have talked about the design of filters in the receiver front, we turn our attention to the design of the rest of the components. Normally these components consist of circuits such as LNA, mixer, IF amplifier, and analog/digital (A/D) converter. Unlike filters, their relevant design parameters are different. Hence our first task is to discuss these design parameters.

(Source: VLSI for Wireless Communication)

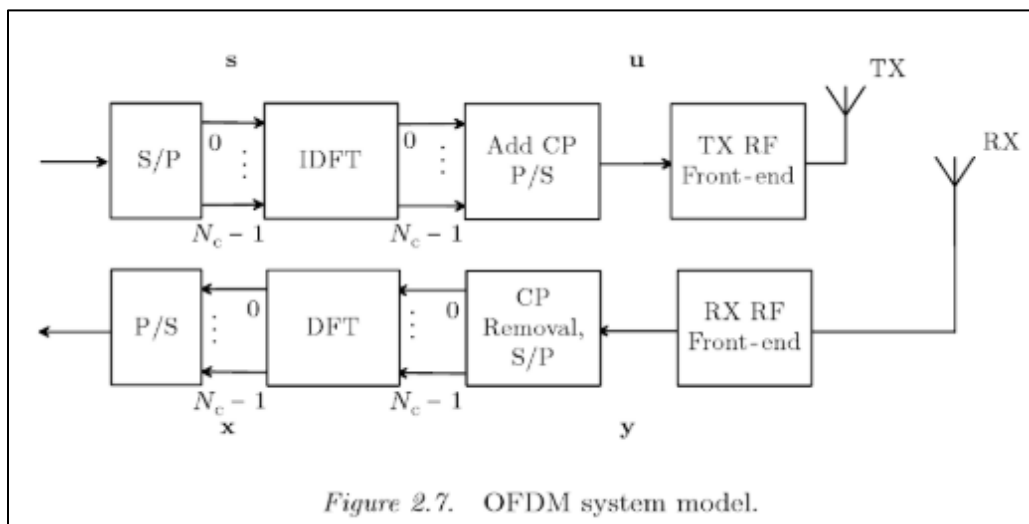

(Source: RF Imperfections in High-rate Wireless Systems: Impact and Digital Compression, Schenk, Tim)

The RF front end is generally defined as everything between the antenna and the digital baseband system. For a receiver, this "between" area includes all the filters, low-noise amplifiers (LNAs), and down-conversion mixer(s) needed to process the modulated signals received at the antenna into signals suitable for input into the baseband analog-to-digital converter (ADC). For this reason, the RF front end is often called the analog-to-digital or RF-to-baseband portion of a receiver.

(Source: https://www.eetimes.com/document.asp?doc_id=1276331)

63. The accused products include the synchronization circuit having one input connected to an output of the ADC. The PPDU frames that are transmitted are demodulated at the receiver end. The demodulation process includes estimating time and frequency offsets and synchronizing accordingly.

20.3.21.7.4 Transmitter modulation accuracy (EVM) test

The transmit modulation accuracy test shall be performed by instrumentation capable of converting the transmitted signals into a streams of complex samples at 40 Msample/s or more, with sufficient accuracy in terms of I/Q arm amplitude and phase balance, dc offsets, phase noise, and analog-to-digital quantization noise. Each transmit chain is connected directly through a cable to the setup input port. A possible embodiment of such a setup is converting the signals to a low intermediate frequency with a microwave synthesizer, sampling the signal with a digital oscilloscope, and decomposing it digitally into quadrature components. The sampled signal shall be processed in a manner similar to an actual receiver, according to the following steps, or an equivalent procedure:

- a) Detect the start of frame.
- b) Detect the transition from short sequences to channel estimation sequences, and establish fine timing (with one sample resolution).
- c) Estimate the coarse and fine frequency offsets.
- d) Derotate the frame according to estimated frequency offset.
- e) Estimate the complex channel response coefficients for each of the subcarriers and each of the transmit chains.
- f) For each of the data OFDM symbols, transform the symbol into subcarrier received values, estimate the phase from the pilot subcarriers in all spatial streams, derotate the subcarrier values according to estimated phase, group the results from all the receiver chains in each subcarrier to a vector, multiply the vector by a zero-forcing equalization matrix generated from the channel estimated during the channel estimation phase.
- g) For each data-carrying subcarrier in each spatial stream, find the closest constellation point and compute the Euclidean distance from it.
- h) Compute the average of the RMS of all errors in a frame. It is given by Equation (20-89).

(Source: <https://web.archive.org/web/20190220214328/http://luci.subsignal.org/~jow/802.11n-2009.pdf>)

The RF front end is generally defined as everything between the antenna and the digital baseband system. For a receiver, this "between" area includes all the filters, low-noise amplifiers (LNAs), and down-conversion mixer(s) needed to process the modulated signals received at the antenna into signals suitable for input into the baseband analog-to-digital converter (ADC). For this reason, the RF front end is often called the analog-to-digital or RF-to-baseband portion of a receiver.

(Source: https://www.eetimes.com/document.asp?doc_id=1276331)

64. The accused products include a cyclic-prefix remover connected to an output of the synchronization circuit, a serial-to-parallel converter connected to an output of the cyclic prefix remover, and a discrete Fourier transform (DFT) stage connected to an output of the serial-to-parallel converter, an output of the DFT stage connected to another input to the synchronization circuit. Cyclic prefixes are added in the preamble for each transmitted frame. In a general OFDM system, a cyclic prefix remover circuit would be present at the receiver end. The output from the cyclic prefix remover circuit would be fed to a serial-to-parallel converter for performing a DFT operation on its output. The evidence also shows that the output of the DFT stage is connected to the phase correction block that is part of the synchronization circuit.

The encoding process is composed of the steps described below. The following overview is intended to facilitate an understanding of the details of the convergence procedure:

- a) Determine the number of transmit chains, N_{TX} , from the N_TX field of the TXVECTOR. Produce the PLCP preamble training fields for each of the N_{TX} transmit chains based on the FORMAT, NUM_EXTEN_SS, CH_BANDWIDTH, and MCS parameters of the TXVECTOR. The format and relative placement of the PLCP preamble training fields vary depending on the frame format being used, as indicated by these parameters. Apply cyclic shifts. Determine spatial mapping to be used for HT-STF and HT-LTFs in HT-mixed format frame and HT-GF-STF and HT-LTFs in HT-greenfield format frame from the EXPANSION_MAT parameter of the TXVECTOR. Refer to 20.3.9 for details.
- b) Construct the PLCP preamble SIGNAL fields from the appropriate fields of the TXVECTOR by adding tail bits, applying convolutional coding, formatting into one or more OFDM symbols, applying cyclic shifts, applying spatial processing, calculating an inverse Fourier transform for each OFDM symbol and transmit chain, and prepending a cyclic prefix or GI to each OFDM symbol in each transmit chain. The number and placement of the PLCP preamble SIGNAL fields depend on the frame format being used. Refer to 20.3.9.3.5, 20.3.9.4.3, and 20.3.9.5.3.
- c) Concatenate the PLCP preamble training and SIGNAL fields for each transmit chain one field after another, in the appropriate order, as described in 20.3.2 and 20.3.7.

(Source: <https://web.archive.org/web/20190220214328/http://luci.subsignal.org/~jow/802.11n-2009.pdf>)

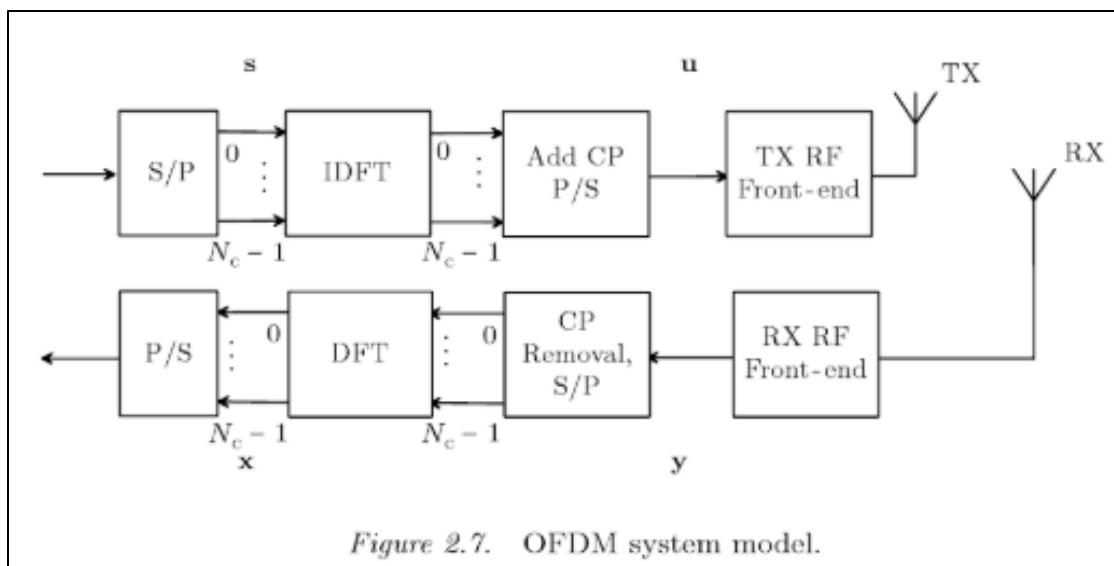

(Source: RF Imperfections in High-rate Wireless Systems: Impact and Digital Compression, Schenk, Tim)

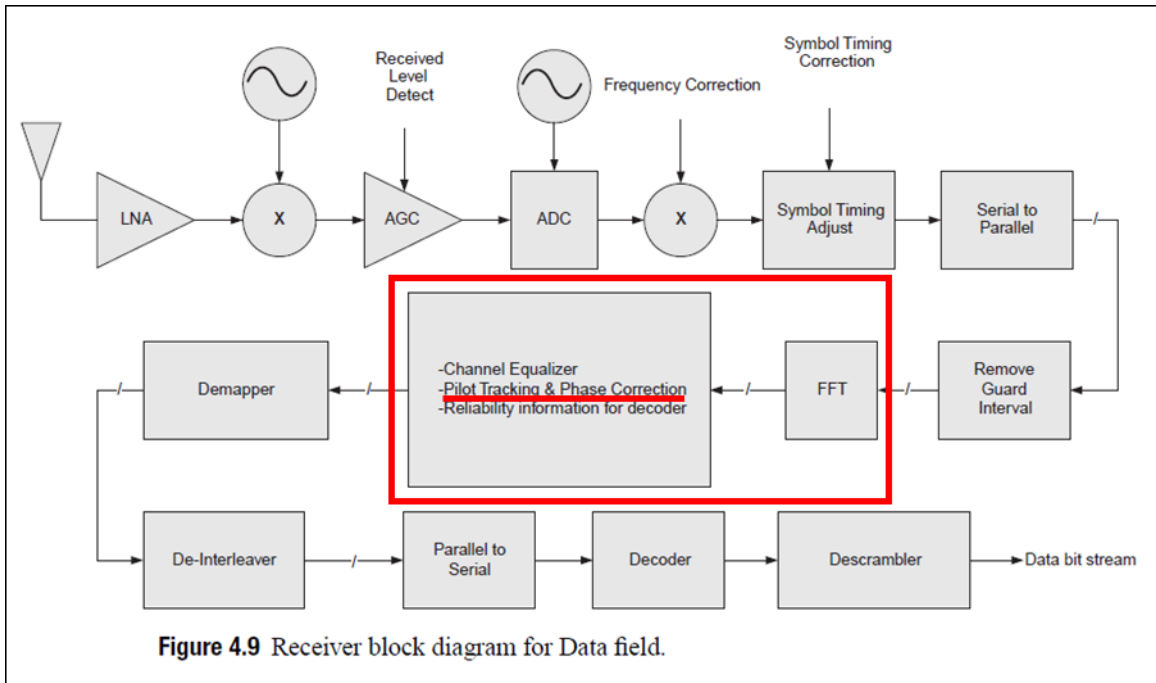

(Source: Next Generation Wireless LANs: 802.11n and 802.11ac, Perahia, Eldad and Stacey, Robert)

65. Qualcomm has directly infringed at least through its making and use of the accused products through its own testing of the accused products, and through joint infringement with its affiliates, with its subsidiaries, with carriers, with retailers and other sales entities, with its business partners, with certification organizations, with testing organizations, with other agents of Qualcomm, and/or with its customers and end-users, at least making and using the claimed apparatus. Such acts of infringement include directing or controlling other persons to engage in conduct satisfying one or more elements of the asserted claims, deriving a financial or other benefit from doing so. Qualcomm's direction or control of its affiliates and end-users includes regularly contracting with those affiliates and end-users. Also, as explained further below, Qualcomm took active steps and advised or directed customers and end-users to make and/or use the accused products in an infringing manner.

66. Qualcomm has had knowledge of the '458 Patent at least as of its issuance on April 27, 2010. For example, on November 21, 2008, the '458 Patent's parent, the '782 Patent, was used in the first of five office actions during prosecution of U.S. Patent Application No. 11/313,555. That application issued as U.S. Patent No. 8,130,726, titled "Coarse Bin Frequency Synchronization In A Communication System" and was assigned to Qualcomm Inc. The examiner during that prosecution explained that "Mody teaches an OFDM system that has multiple frequency offset estimation circuits/calculators (e.g. identifies and offsets frequency errors). There are Coarse and Fine Synchronization circuits as well as first/second/etc. offset estimation circuits. (see figure 8. Notice that these components are all contained in a Synchronization Circuit)." Qualcomm employee Kuei-Chiang Lai, who is listed as an inventor on U.S. Patent No. 8,130,726, and others involved in the prosecution of the patent, have had knowledge of the '458 Patent at least as of April 27, 2010.

67. Qualcomm has had knowledge of the '458 Patent at least as of its issuance on April 27, 2010. For example, on April 6, 2009, the '458 Patent's parent, the '782 Patent, was cited and described by the examiner ("Mody et al (US Pat. No. 7,088,782) discloses a coarse and fine frequency synchronization wherein an OFDM signal frequency offset is estimated, corrected, and transmitted for further signal processing prior to being refined in a second frequency offset estimation and correction stage.") during the prosecution of U.S. Patent Application No. 11/322,538. That application issued as U.S. Patent No. 7,558,245, titled "Method And Apparatus For Time And Frequency Synchronization Of OFDM Communication Systems" and was assigned to Qualcomm Inc. Qualcomm employees Rajiv Laroia, Junyi Li, Sundeep Rangan, and Hemanth T. Sampath, who are listed as inventors on U.S. Patent No.

7,558,245, and others involved in the prosecution of the patent, including Michael P. Straub, have had knowledge of the '458 Patent at least as of April 27, 2010.

68. Qualcomm has also cited the '458 Patent's parent, the '782 Patent, during the prosecution of at least five other patents. For example, Qualcomm has had knowledge of the '458 Patent at least as of its issuance on April 27, 2010. On October 13, 2009, Qualcomm cited the '782 Patent in an Information Disclosure Statement during the prosecution of U.S. Patent Application No. 12/552,705. That application issued as U.S. Patent No. 8,743,837, titled "Modified Preamble Structure For IEEE 802.11A Extensions To Allow For Coexistence And Interoperability Between 802.11A Devices And Higher Data Rate, MIMO Or Otherwise Extended Devices" and was assigned to Qualcomm Inc. Qualcomm employees Albert van Zelst and Richard van Nee, who are listed as inventors on U.S. Patent No. 8,743,837, and others involved in the prosecution of the patent, have had knowledge of the '458 Patent at least as of its issuance on April 27, 2010.

69. Likewise, Qualcomm has had knowledge of the '458 Patent at least as of March 13, 2012, when it cited the '458 Patent's parent, the '782 Patent, in an Information Disclosure Statement during the prosecution of U.S. Patent Application No. 12/469,323. That application issued as U.S. Patent No. 8,457,232, titled "Detecting The Number Of Transmit Antennas In Wireless Communication Systems" and was assigned to Qualcomm Inc. Qualcomm employees Albert van Zelst and Richard van Nee, who are listed as inventors on U.S. Patent No. 8,457,232, and others involved in the prosecution of the patent, including Thomas E. Watson and William E. Curry, have had knowledge of the '458 Patent at least as of March 13, 2012.

70. Qualcomm has had actual knowledge of the '458 Patent at least as of the date when it was notified of the filing of this action. By the time of trial, Qualcomm will have known

and intended (since receiving such notice) that its continued actions would infringe and actively induce and contribute to the infringement of one or more claims of the ‘458 Patent.

71. Qualcomm has also indirectly and willfully infringed, and continues to indirectly and willfully infringe, the ‘458 Patent, as explained further below in the “Additional Allegations Regarding Infringement and Personal Jurisdiction” section.

72. American Patents has been damaged as a result of the infringing conduct by Qualcomm alleged above. Thus, Qualcomm is liable to American Patents in an amount that adequately compensates it for such infringements, which, by law, cannot be less than a reasonable royalty, together with interest and costs as fixed by this Court under 35 U.S.C. § 284.

73. American Patents has neither made nor sold unmarked articles that practice the ‘458 Patent, and is entitled to collect pre-filing damages for the full period allowed by law for infringement of the ‘458 Patent.

**ADDITIONAL ALLEGATIONS REGARDING INFRINGEMENT
AND PERSONAL JURISDICTION**

74. In addition to any specific products mentioned above, the accused products also include at least the following products: Qualcomm 5G Fixed Wireless Access Platform gen 2, Qualcomm Snapdragon X50 5G Modem-RF System, Qualcomm Snapdragon X55 5G Modem-RF System, Qualcomm Snapdragon X60 5G Modem-RF System, Qualcomm Snapdragon X62 5G Modem-RF System, Qualcomm Snapdragon X65 5G Modem-RF System, Qualcomm Snapdragon X70 Modem-RF System, Qualcomm FSM200xx, Qualcomm Smart Audio 400 Platform, Qualcomm Snapdragon Auto 4G Modem, Qualcomm Snapdragon Auto 5G Modem-RF, Qualcomm Snapdragon 602 Automotive Platform, Qualcomm Snapdragon 820 Automotive Platform, Qualcomm Snapdragon 7c Compute Platform, Qualcomm Snapdragon 7c Gen 2 Compute Platform, Qualcomm Snapdragon 7c+ Gen 3 Compute Platform, Qualcomm

Snapdragon 835 Mobile PC Platform, Qualcomm Snapdragon 850 Mobile Compute Platform, Qualcomm Snapdragon 8c Compute Platform, Qualcomm Snapdragon 8cx Compute Platform, Qualcomm Snapdragon 8cx Gen 2 5G Compute Platform, Qualcomm Snapdragon 8cx Gen 3 Compute Platform, Qualcomm Snapdragon System-in-Package, Qualcomm Home Hub 100 Dev Kit for Amazon AVS, Qualcomm Mesh Networking Dev Kit for Amazon AVS, Qualcomm FastConnect 6200, Qualcomm FastConnect 6700, Qualcomm FastConnect 6800, Qualcomm FastConnect 6900, Qualcomm FastConnect 7800, Qualcomm Snapdragon G3x Gen 1 Gaming Platform, Qualcomm Home Hub 100 Platform, Qualcomm Immersive Home 214 Platform, Qualcomm Immersive Home 216 Platform, Qualcomm Immersive Home 316 Platform, Qualcomm Immersive Home 318 Platform, Qualcomm 315 5G IoT Modem, Qualcomm Flight RB5 5G Platform, Qualcomm AR6004 Chipset, Qualcomm 9207 LTE Modem, Qualcomm Snapdragon X12 LTE Modem, Qualcomm Snapdragon X16 LTE Modem, Qualcomm Snapdragon X20 LTE Modem, Qualcomm Snapdragon X24 LTE Modem, Qualcomm Snapdragon X5 LTE Modem, Qualcomm Snapdragon X7 LTE Modem, Qualcomm Qualcomm 205 Mobile Platform, Qualcomm Qualcomm 215 Mobile Platform, Qualcomm Snapdragon 212 Mobile Platform, Qualcomm Snapdragon 425 Mobile Platform, Qualcomm Snapdragon 427 Mobile Platform, Qualcomm Snapdragon 429 Mobile Platform, Qualcomm Snapdragon 430 Mobile Platform, Qualcomm Snapdragon 435 Mobile Platform, Qualcomm Snapdragon 439 Mobile Platform, Qualcomm Snapdragon 450 Mobile Platform, Qualcomm Snapdragon 460 Mobile Platform, Qualcomm Snapdragon 480 5G Mobile Platform, Qualcomm Snapdragon 480+ 5G Mobile Platform, Qualcomm Snapdragon 625 Mobile Platform, Qualcomm Snapdragon 626 Mobile Platform, Qualcomm Snapdragon 630 Mobile Platform, Qualcomm Snapdragon 632 Mobile Platform, Qualcomm Snapdragon 636 Mobile Platform, Qualcomm

Snapdragon 650 Mobile Platform, Qualcomm Snapdragon 652 Mobile Platform, Qualcomm Snapdragon 653 Mobile Platform, Qualcomm Snapdragon 660 Mobile Platform, Qualcomm Snapdragon 662 Mobile Platform, Qualcomm Snapdragon 665 Mobile Platform, Qualcomm Snapdragon 670 Mobile Platform, Qualcomm Snapdragon 675 Mobile Platform, Qualcomm Snapdragon 678 Mobile Platform, Qualcomm Snapdragon 680 4G Mobile Platform, Qualcomm Snapdragon 690 5G Mobile Platform, Qualcomm Snapdragon 695 5G Mobile Platform, Qualcomm Snapdragon 710 Mobile Platform, Qualcomm Snapdragon 712 Mobile Platform, Qualcomm Snapdragon 720G Mobile Platform, Qualcomm Snapdragon 730 Mobile Platform, Qualcomm Snapdragon 730G Mobile Platform, Qualcomm Snapdragon 732G Mobile Platform, Qualcomm Snapdragon 750G 5G Mobile Platform, Qualcomm Snapdragon 765 5G Mobile Platform, Qualcomm Snapdragon 765G 5G Mobile Platform, Qualcomm Snapdragon 768G 5G Mobile Platform, Qualcomm Snapdragon 778G 5G Mobile Platform, Qualcomm Snapdragon 778G+ 5G Mobile Platform, Qualcomm Snapdragon 780G 5G Mobile Platform, Qualcomm Snapdragon 8 Gen 1 Mobile Platform, Qualcomm Snapdragon 820 Mobile Platform, Qualcomm Snapdragon 821 Mobile Platform, Qualcomm Snapdragon 835 Mobile Platform, Qualcomm Snapdragon 845 Mobile Platform, Qualcomm Snapdragon 855 Mobile Platform, Qualcomm Snapdragon 855+/860 Mobile Platform, Qualcomm Snapdragon 865 5G Mobile Platform, Qualcomm Snapdragon 865+ 5G Mobile Platform, Qualcomm Snapdragon 870 5G Mobile Platform, Qualcomm Snapdragon 888 5G Mobile Platform, Qualcomm Snapdragon 888+ 5G Mobile Platform, Qualcomm CSRS3718, Qualcomm DragonBoard 410c, Qualcomm Snapdragon 200 Processor, Qualcomm Snapdragon 208 Processor, Qualcomm Snapdragon 210 Processor, Qualcomm Snapdragon 400 Processor, Qualcomm Snapdragon 410 Processor, Qualcomm Snapdragon 412 Processor, Qualcomm Snapdragon 415 Processor, Qualcomm

Snapdragon 600 Processor, Qualcomm Snapdragon 610 Processor, Qualcomm Snapdragon 615 Processor, Qualcomm Snapdragon 616 Processor, Qualcomm Snapdragon 617 Processor, Qualcomm Snapdragon 800 Processor, Qualcomm Snapdragon 801 Processor, Qualcomm Snapdragon 805 Processor, Qualcomm Snapdragon 808 Processor, Qualcomm Snapdragon 810 Processor, Qualcomm Robotics RB3 Platform, Qualcomm Robotics RB5 Platform, Qualcomm Smart Audio 200 Platform, Qualcomm Smart Display 200 Platform, Qualcomm APQ8009, Qualcomm APQ8016E, Qualcomm APQ8053, Qualcomm APQ8074, Qualcomm APQ8094, Qualcomm APQ8096SG, Qualcomm APQ8098, Qualcomm CSRS3703, Qualcomm CSRS3713, Qualcomm IPQ4018 SoC, Qualcomm IPQ4019 SoC, Qualcomm IPQ4028 SoC, Qualcomm IPQ4029 SoC, Qualcomm IPQ8074, Qualcomm QCA1062, Qualcomm QCA1064, Qualcomm QCA206x, Qualcomm QCA4002, Qualcomm QCA4004, Qualcomm QCA4010, Qualcomm QCA4012, Qualcomm QCA4020, Qualcomm QCA4531, Qualcomm QCA6174A, Qualcomm QCA6175A, Qualcomm QCA6335, Qualcomm QCA6436, Qualcomm QCA6564AU, Qualcomm QCA6574AU, Qualcomm QCA6595AU, Qualcomm QCA6696, Qualcomm QCA9377, Qualcomm QCA9379, Qualcomm QCA9500, Qualcomm QCA9531, Qualcomm QCA9565, Qualcomm QCA9886 SoC, Qualcomm QCA9887 SoC, Qualcomm QCA9888 SoC, Qualcomm QCA9889 SoC, Qualcomm QCA9980, Qualcomm QCA9982 SoC, Qualcomm QCA9984 SoC, Qualcomm QCA9990 SoC, Qualcomm QCA9992 SoC, Qualcomm QCA9994 SoC, Qualcomm QCM2150, Qualcomm QCM2290, Qualcomm QCM6490, Qualcomm QCN7605, Qualcomm QCS400 Series, Qualcomm QCS403, Qualcomm QCS404, Qualcomm QCS405, Qualcomm QCS407, Qualcomm QCS410, Qualcomm QCS4290, Qualcomm QCS603, Qualcomm QCS605, Qualcomm QCS610, Qualcomm QCS6125, Qualcomm QCS7230, Qualcomm QCS8250, Qualcomm SDA660, Qualcomm SDA845, Qualcomm SDM660,

Qualcomm SDM845, Qualcomm Vision Intelligence 100 Platform, Qualcomm Vision Intelligence 200 Platform, Qualcomm Vision Intelligence 300 Platform, Qualcomm Vision Intelligence 400 Platform, Qualcomm Snapdragon 1100 Wearable Platform, Qualcomm Snapdragon 1200 Wearable Platform, Qualcomm Snapdragon Wear 2100 Platform, Qualcomm Snapdragon Wear 2500 Platform, Qualcomm Snapdragon Wear 3100 Platform, Qualcomm Snapdragon Wear 4100+ Platform, Qualcomm Networking Pro 1200 Platform, Qualcomm Networking Pro 1210 Platform, Qualcomm Networking Pro 1610 Platform, Qualcomm Networking Pro 400 Platform, Qualcomm Networking Pro 600 Platform, Qualcomm Networking Pro 610 Platform, Qualcomm Networking Pro 800 Platform, and Qualcomm Networking Pro 810 Platform.

75. Qualcomm has also indirectly infringed the '782 Patent, the '304 Patent, and the '458 Patent by inducing others to directly infringe the '782 Patent, the '304 Patent, and the '458 Patent. Qualcomm has induced the end-users, Qualcomm's customers, to directly infringe (literally and/or under the doctrine of equivalents) the '782 Patent, the '304 Patent, and the '458 Patent by using the accused products.

76. Qualcomm took active steps, directly and/or through contractual relationships with others, with the specific intent to cause them to use the accused products in a manner that infringes one or more claims of the patents-in-suit, including, for example, Claim 30 of the '782 Patent, Claim 1 of the '304 Patent, and Claim 1 of the '458 Patent.

77. Such steps by Qualcomm included, among other things, advising or directing customers and end-users to use the accused products in an infringing manner; advertising and promoting the use of the accused products in an infringing manner; and/or distributing instructions that guide users to use the accused products in an infringing manner.

78. Qualcomm has performed these steps, which constitute induced infringement, with the knowledge of the '782 Patent, the '304 Patent, and the '458 Patent and with the knowledge that the induced acts constitute infringement.

79. Qualcomm was and is aware that the normal and customary use of the accused products by Qualcomm's customers would infringe the '782 Patent, the '304 Patent, and the '458 Patent. Qualcomm's inducement is ongoing.

80. Qualcomm has also induced its affiliates, or third-party manufacturers, shippers, distributors, retailers, or other persons acting on its or its affiliates' behalf, to directly infringe (literally and/or under the doctrine of equivalents) the '782 Patent, the '304 Patent, and the '458 Patent by importing, selling, offering to sell, and/or using the accused products.

81. Qualcomm has at least a significant role in placing the accused products in the stream of commerce with the expectation and knowledge that they will be purchased by consumers in Texas and elsewhere in the United States.

82. Qualcomm purposefully directs or controls the making of accused products and their shipment to the United States, using established distribution channels, for sale in Texas and elsewhere within the United States.

83. Qualcomm purposefully directs or controls the sale of the accused products into established United States distribution channels, including sales to nationwide retailers, distributors, manufacturers, and design laboratories (including, but not limited to, Arrow, Go2 Technical Sales, Infinity Sales, Innovatech Associates, Johnson Company, Omega Electronic Sales, Inc., Quad State Sales and Marketing, Rathsburg Associates, and Tri-Tech Electronics).

84. Qualcomm's established United States distribution channels include one or more United States based affiliates.

85. Qualcomm purposefully directs or controls the sale of the accused products online and in nationwide retailers, including for sale in Texas and elsewhere in the United States, and expects and intends that the accused products will be so sold.

86. Qualcomm purposefully places the accused products—whether by itself or through subsidiaries, affiliates, or third parties—into an international supply chain, knowing the accused products will be sold in the United States, including Texas. Therefore, Qualcomm also facilitates the sale of the accused products in Texas.

87. Qualcomm took active steps, directly and/or through contractual relationships with others, with the specific intent to cause such persons to import, sell, or offer to sell the accused products in a manner that infringes one or more claims of the patents-in-suit, including, for example, Claim 30 of the '782 Patent, Claim 1 of the '304 Patent, and Claim 1 of the '458 Patent.

88. Such steps by Qualcomm included, among other things, making or selling the accused products outside of the United States for importation into or sale in the United States, or knowing that such importation or sale would occur; and directing, facilitating, or influencing its affiliates, or third-party manufacturers, shippers, distributors, retailers, or other persons acting on its or their behalf, to import, sell, or offer to sell the accused products in an infringing manner.

89. Qualcomm performed these steps, which constitute induced infringement, with the knowledge of the '782 Patent, the '304 Patent, and the '458 Patent and with the knowledge that the induced acts would constitute infringement.

90. Qualcomm performed such steps in order to profit from the eventual sale of the accused products in the United States.

91. Qualcomm's inducement is ongoing.

92. Qualcomm has also indirectly infringed by contributing to the infringement of the '782 Patent, the '304 Patent, and the '458 Patent. Qualcomm has contributed to the direct infringement of the '782 Patent, the '304 Patent, and the '458 Patent by the end-user of the accused products.

93. The accused products have special features that are specially designed to be used in an infringing way and that have no substantial uses other than ones that infringe the '782 Patent, the '304 Patent, and the '458 Patent, including, for example, Claim 30 of the '782 Patent, Claim 1 of the '304 Patent, and Claim 1 of the '458 Patent.

94. As described above, the special features include improved wireless communication capabilities used in a manner that infringes the '782 Patent, the '304 Patent, and the '458 Patent.

95. The special features constitute a material part of the invention of one or more of the claims of the '782 Patent, the '304 Patent, and the '458 Patent and are not staple articles of commerce suitable for substantial non-infringing use.

96. Qualcomm's contributory infringement is ongoing.

97. Qualcomm has had actual knowledge of the '782 Patent, the '304 Patent, and the '458 Patent at least as of the date when it was notified of the filing of this action. Since at least that time, Qualcomm has known the scope of the claims of the '782 Patent, the '304 Patent, and the '458 Patent, the products that practice the '782 Patent, the '304 Patent, and the '458 Patent, and that American Patents is the owner of the '782 Patent, the '304 Patent, and the '458 Patent.

98. By the time of trial, Qualcomm will have known and intended (since receiving such notice) that its continued actions would infringe and actively induce and contribute to the infringement of one or more claims of the '782 Patent, the '304 Patent, and the '458 Patent.

99. Furthermore, Qualcomm has a policy or practice of not reviewing the patents of others (including instructing its employees to not review the patents of others), and thus has been willfully blind of American Patents' patent rights. *See, e.g.*, M. Lemley, "Ignoring Patents," 2008 Mich. St. L. Rev. 19 (2008).

100. Qualcomm has knowledge of the '782 Patent, the '304 Patent, and the '458 Patent.

101. Qualcomm's customers have infringed the '782 Patent, the '304 Patent, and the '458 Patent.

102. Qualcomm encouraged its customers' infringement.

103. Qualcomm's direct and indirect infringement of the '782 Patent, the '304 Patent, and the '458 Patent is, has been, and/or continues to be willful, intentional, deliberate, and/or in conscious disregard of American Patents' rights under the patents.

104. American Patents has been damaged as a result of the infringing conduct by Qualcomm alleged above. Thus, Qualcomm is liable to American Patents in an amount that adequately compensates it for such infringements, which, by law, cannot be less than a reasonable royalty, together with interest and costs as fixed by this Court under 35 U.S.C. § 284.

JURY DEMAND

American Patents hereby requests a trial by jury on all issues so triable by right.

PRAYER FOR RELIEF

American Patents requests that the Court find in its favor and against Qualcomm, and that the Court grant American Patents the following relief:

a. Judgment that one or more claims of the '782 Patent, the '304 Patent, and the '458 Patent have been infringed, either literally and/or under the doctrine of equivalents, by

Qualcomm and/or all others acting in concert therewith;

b. A permanent injunction enjoining Qualcomm and its officers, directors, agents, servants, affiliates, employees, divisions, branches, subsidiaries, parents, and all others acting in concert therewith from infringement of the '782 Patent, the '304 Patent, and the '458 Patent; or, in the alternative, an award of a reasonable ongoing royalty for future infringement of the '782 Patent, the '304 Patent, and the '458 Patent by such entities;

c. Judgment that Qualcomm account for and pay to American Patents all damages to and costs incurred by American Patents because of Qualcomm's infringing activities and other conduct complained of herein, including an award of all increased damages to which American Patents is entitled under 35 U.S.C. § 284;

d. That American Patents be granted pre-judgment and post-judgment interest on the damages caused by Qualcomm's infringing activities and other conduct complained of herein;

e. That this Court declare this an exceptional case and award American Patents its reasonable attorney's fees and costs in accordance with 35 U.S.C. § 285; and

f. That American Patents be granted such other and further relief as the Court may deem just and proper under the circumstances.

Dated: July 12, 2022

Respectfully submitted,

/s/ Zachariah S. Harrington

Matthew J. Antonelli

Texas Bar No. 24068432

matt@ahtlawfirm.com

Zachariah S. Harrington

Texas Bar No. 24057886

zac@ahtlawfirm.com

Larry D. Thompson, Jr.

Texas Bar No. 24051428

larry@ahtlawfirm.com

Christopher Ryan Pinckney

Texas Bar No. 24067819

ryan@ahtlawfirm.com

ANTONELLI, HARRINGTON
& THOMPSON LLP
4306 Yoakum Blvd., Ste. 450
Houston, TX 77006
(713) 581-3000

Stafford Davis
State Bar No. 24054605
sdavis@stafforddavisfirm.com
Catherine Bartles
Texas Bar No. 24104849
cbartles@stafforddavisfirm.com
THE STAFFORD DAVIS FIRM
815 South Broadway Avenue
Tyler, Texas 75701
(903) 593-7000
(903) 705-7369 fax

Attorneys for American Patents LLC