

**IN THE UNITED STATES DISTRICT COURT
FOR THE WESTERN DISTRICT OF TEXAS
WACO DIVISION**

PRESERVATION TECHNOLOGIES LLC,

Plaintiff,

v.

WGCZ LIMITED, S.R.O., WGCZ
HOLDING, A.S., WEBGROUP CZECH
REPUBLIC, A.S., NKL ASSOCIATES,
S.R.O., WEBPROCESSING S.R.O., and
BRIDGEMAZE PARTNERS, S.R.O.

Defendants.

CIVIL ACTION NO. 6:22-cv-00025

JURY TRIAL DEMANDED

FIRST AMENDED COMPLAINT

Plaintiff Preservation Technologies LLC (“Preservation” or “Plaintiff”), by and through its attorneys, for its First Amended Complaint against WGCZ Limited, s.r.o., WGCZ Holding, a.s., WebGroup Czech Republic, a.s., NKL Associates s.r.o., Webprocessing s.r.o., and Bridgemaze Partners s.r.o., (collectively, “WGCZ” or “Defendants”), hereby alleges as follows:

I. NATURE OF THE ACTION

1. This is a patent infringement action to end Defendants’ direct, joint, contributory, and/or induced infringement of Plaintiff’s patented inventions, including but not limited to Defendants’ unauthorized and infringing use, sale, offering for sale, manufacture, and/or importation of methods and products incorporating Plaintiff’s inventions.

2. Preservation has obtained all substantial rights and interest to U.S. Patent No. 5,813,014, U.S. Patent No. 5,832,499, U.S. Patent No. 6,092,080, U.S. Patent No. 6,353,831, U.S. Patent No. 5,832,495, U.S. Patent No. 6,477,537, U.S. Patent No. 6,199,060, U.S. Patent No. 6,212,527, U.S. Patent No. 6,549,911, U.S. Patent No. 6,581,071, and U.S. Patent No. 6,574,638 (collectively, the “Asserted Patents” or “Patents-in-Suit”).

3. Defendants provide, use, put into use, sell, offer for sale, distribute, manufacture, and/or import infringing products and services, and encourage others, including their customers, to use Defendants' products and services in an infringing manner.

4. Plaintiff seeks to prevent Defendants from continuing infringement of Plaintiff's patent rights. Plaintiff further seeks past and future damages and prejudgment and post judgment interest for Defendants' past infringement of the Asserted Patents.

II. PARTIES

5. Plaintiff is a limited liability company organized and existing under the laws of the State of Delaware, with its principal place of business located at 903 E. 18th Street, Suite 223, Plano, TX 75074.

6. Defendants lead a corporate group consisting of entities that operate accused adult websites, specifically including XVideos, XNXX and Penthouse (among other sites enumerated in Section VII) and conduct other activities within the United States. Among other activities, WGCZ is one of the largest distributors of Internet pornography in the world. A significant part of the Defendant's business model is to provide free pornography to website visitors in the United States. By providing free pornography, Defendants attract a substantial number of website visitors which allows Defendants to make a large portion of its revenue from advertising from United States companies. Additionally, website visitors can purchase paid subscriptions to premium websites, such as XVideos Red and XNXX Gold, within the United States.

7. WGCZ Limited., s.r.o. ("WGCZ Ltd., s.r.o") is a limited company existing under the laws of the Czech Republic, and having a place of business at Praha 1 - Nové Město, Krakovská 1366/25, PSČ 110 00 Czech Republic.

8. WGCZ Ltd., s.r.o. has subjected itself to the jurisdiction of the district courts of the United States, including *inter alia* by appearing in and acquiring Penthouse Global Media Inc. in

2018. *See* EXHIBITS 1 & 2 (*In re Penthouse Global Media, Inc.*, Case No, 1:18-bk-10098 MB in the United States District Court for the Central District of California, Docket Nos. 576 and 918). Paul Brent of Steinberg, Nutter & Brent Law Corporation appeared on behalf of WGCZ Ltd., s.r.o. and will be served with process via Federal Express. *See id.*

9. WGCZ Ltd., s.r.o. was also a named defendant in a copyright infringement lawsuit styled *Hydrenta HLP Int. Limited v. WGCZ, s.r.o. et al*, Case No. 2:15-cv-01250-LDG-NJK brought in the United States District Court for the District of Nevada. Michael T. Zeller of Quinn Emanuel Urquart & Sullivan, LLP represented WGCZ Ltd., s.r.o. *See* Exhibit 3.

10. WGCZ Holding, as (“WGCZ Holding”) is a limited liability company existing under the laws of the Czech Republic, and having a place of business at Praha 1 - Nové Město, Krakovská 1366/25, PSČ 110 00 Czech Republic.

11. WGCZ Holding was also a named defendant in a sex trafficking lawsuit brought in the United States District Court for the Central District of California, Case No. 2:21-cv-02428-VAP-SK. Michael T. Zeller of Quinn Emanuel Urquart & Sullivan, LLP represented WGCZ Holding and executed a waiver of service of process. *See* Exhibits 4 & 5.

12. WebGroup Czech Republic, a.s. (formerly WGCZ, s.r.o. and WGCZ, a.s.) (“WebGroup Czech Republic”), is a joint stock company with a place of business at Krakovská 1366/25, Nové Město, 110 00 Prague, and is owned and/or managed by Malorie Pacaud; Stephane Pacaud; Marjorie Grocq; Robert Seifert; and formerly by LK Management Limited; Konečná & Zacha, s.r.o., law office, IČ; and Kateřina Pokorná.

13. WebGroup Czech Republic owns the XVideos and XVideos Red trademarks. WebGroup Czech Republic owns and operates XVideos.

14. WebGroup Czech Republic was also a named defendant in a sex trafficking lawsuit brought in the United States District Court for the Central District of California, Case No. 2:21-cv-02428-VAP-SK. Michael T. Zeller of Quinn Emanuel Urquart & Sullivan, LLP represented WebGroup Czech Republic and executed a waiver of service of process. *See* Exhibits 4 & 5.

15. NKL Associates s.r.o., (“NKL”) is a limited liability company with a place of business at Krakovská 1366/25, Nové Město, 110 00 Prague, and is owned and/or managed by Malorie Pacaud; Stephane Pacaud; Marjorie Grocq; Robert Seifert, and formerly LK Management Limited.

16. NKL owns the XNXX trademarks. NKL owns and operates XNXX.

17. NKL was also a named defendant in a sex trafficking lawsuit brought in the United States District Court for the Central District of California, Case No. 2:21-cv-02428-VAP-SK. Michael T. Zeller of Quinn Emanuel Urquart & Sullivan, LLP represented NKL and executed a waiver of service of process. *See* Exhibits 4 & 5.

18. Webprocessing s.r.o. (“Webprocessing”) is a limited liability company and has a place of business at Pujmanové 1753/10a, Nusle, 140 00 Praha 4 Czech Republic, and is owned and/or managed by František Seifert.

19. Webprocessing owns and operates XVideos Red.

20. Bridgemaze Partners s.r.o. (“Bridgemaze”) is a limited liability company and has a principal place of business at Pujmanové 1753/10a, Nusle, 140 00 Praha 4, and is owned and/or managed by František Seifert.

21. Bridgemaze Partners owns and operates XNXX Gold.

22. The Defendants together operate XVideos (<https://www.xvideos.com/>), XVideos Red (<https://www.xvideos.red/>), XNXX (<https://www.xnxx.com/>), XNXX Gold

(<https://www xnxx gold/>); and all their domains; subdomains; and all related and supporting websites and systems (collectively, the Accused Websites).¹

Alter Ego

23. Upon information and belief, the Defendants operate as a common business enterprise for the purpose of producing, distributing, and monetizing pornography on the Internet, including on the XVideos and XNXX websites. The Defendants' business of creating and distributing pornography is divided among several entities. Multiple entities operate the Accused Websites described herein and exhibit legal and effective control over each of the Defendants, the entities that perform the infringing activities and the infringing activities conduct itself. Many of the Defendants have the same principal place of business and common ownership. Additionally, of the parties that do not share the same principal place of business, trademarks associated with their premium subscription website are owned by WebGroup Czech Republic.

24. On information and belief, Defendants operate as a single enterprise with no independence. Instead, they commonly engage in a blatant abuse of the corporate form through repeated corporate shape-shifting: altering their names, switching directors, deleting some corporations and forming others, but all remaining under the ultimate control and direction of the Pacauds (Malorie Pacaud and Stephane Pacaud – owners of WebGroup Czech Republic) and a few of their close confidants.

25. For example, with regard to WebGroup Czech Republic:

¹ As used herein, the Accused Websites further include all websites (including premium versions) operated by or for the Defendants that use, without limitation, the following platforms (and all other websites operated by or on behalf of the Defendants that use similar domains, systems, platforms and/or protocols).

- a. On information and belief, between 2014 and 2017 Stephane Michael Pacaud and LK Management Ltd registered and re-registered themselves as owners of WGCZ, s.r.o. numerous times, each time with a change of address and a 1% difference in ownership.
- b. On information and belief, in 2017, WGCZ, s.r.o. became a joint stock company, WGCZ, a.s., with Stephane Michael Pacaud and Malorie Deborah Pacaud as the only shareholders. On information and belief, all of the shares were placed in the same account.
- c. On information and belief, in 2020, WGCZ, a.s. became WebGroup Czech Republic, a.s., and, on August 31, 2021, Malorie Deborah Pacaud was deleted from the board of directors, and Robert Seifert was entered as a board member and deleted as a proxy.
- d. On information and belief, based on the annual report and audit of Defendants in 2018, Defendants commingled funds or otherwise had long-term loans with subsidiaries and “related entities”, three of which are listed in U.S. currency in their 2018 annual report.

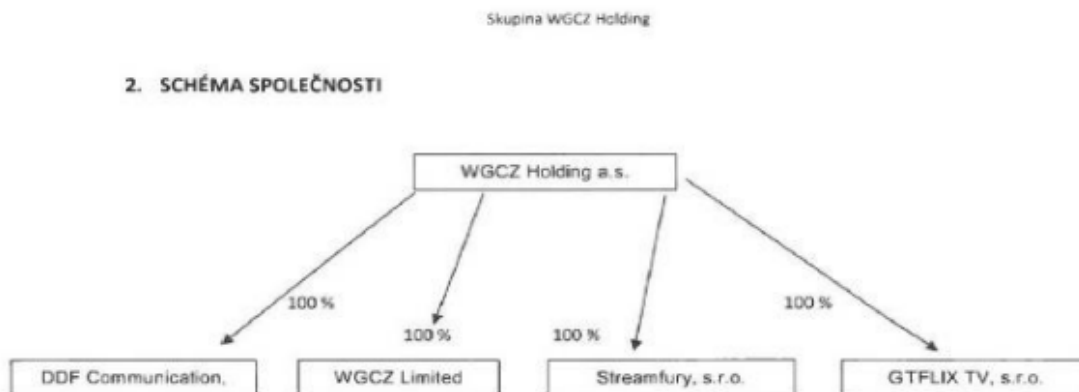

26. On information and belief, in addition to the use of the same corporate officers, similar addresses, Defendants reported in its 2019 annual report as roughly translated, that the relationship between the Subsidiaries and Related Parties provides advantages for the Defendants in particular a significant position in the market, “use of know-how between connected persons, administrative simplification, and optimization of personal resources.” In this period the company did not incur any loss as a result of the “influence” of related parties.

5. Zhodnocení výhod a nevýhod plynoucích ze vztahů dle ustanovení § 82 odst. 2 písm. f) a odst. 4 ZOK

Ze vztahů mezi Propojenými osobami plynou pro Společnost výhody, především významné postavení na trhu, využití know-how mezi Propojenými osobami, administrativní zjednodušení a optimalizace personálních zdrojů

V Účetním období nevznikla Společnosti žádná újma v důsledku vlivu některé z Propojených osob.

Společnosti neplynou ze vztahů mezi Propojenými osobami žádné nevýhody a ani žádná rizika.

27. On information and belief, Stephane Michael Pacaud is, and at all relevant times was, the founder, majority shareholder and an executive of Defendant WebGroup Czech Republic, and its corporate affiliations and alter egos. Mr. Pacaud, along with his sister Malorie Deborah Pacaud, founded and developed WebGroup Czech from its inception and is a primary decision maker with knowledge and control over all aspects of the corporation and its corporate affiliations and alter egos. Mr. Pacaud’s last known residence listed on the Czech business database for WebGroup Czech is Saint Germain au Mont d’Or, 1 Chemin De La Mendillonne, French Republic.

28. On information and belief, Malorie Deborah Pacaud is, and at all relevant times was, a shareholder and an executive of Defendant WebGroup Czech Republic, and its corporate affiliations and alter egos. Ms. Pacaud, along with her brother, Stephane Michael Pacaud, founded and developed WebGroup Czech from its inception and is a primary decision maker with knowledge and control over all aspects of the corporation and its corporate affiliations and alter

egos. Ms. Pacaud's last known residence listed on the Czech business database for WebGroup Czech is Krakovska 593/19, Nové Město, 100 00 Prague 1.

29. Each of the Defendants are related corporations that operate as a single enterprise, act as the alter egos of the others, and essentially as mere conduits whose actions were controlled and ratified by the principals the Pacauds. The entities have created a complex corporate structure designed to operate interactive commercial websites, offer memberships, create content, and transact other related business throughout the world and the United States.

30. The Defendants are alter egos, representatives, agents, or coconspirators of each and its principals the Pacauds. Defendants along with the Pacauds exercise or have the right to exercise control over business operations, management, supervision, administration, and procedures of the Defendants.

31. The Defendants are a single and joint employer with a high degree of interrelated, intermingled, and unified operations for the pornography sites used to benefit from Plaintiff's infringed upon patents. Defendants created a sham to perpetrate fraud and avoid liability and as stated below have failed to observe corporate formalities. They have ignored formal corporate separateness between the controlled entities with respect to capitalization and when exploiting corporate opportunities and using corporate resources and funds.

32. Defendants jointly employ or ratify the employment of individuals through horizontal joint employment and or vertical joint employment and other types of management and control agreements.

33. As an integrated enterprise and or joint employer, Defendants are separately and jointly responsible for compliance with all applicable laws.

34. As an integrated enterprise, Defendants are jointly and severally liable for any damages.

III. JURISDICTION AND VENUE

35. This is an action for patent infringement, which arises under the Patent Laws of the United States, in particular, 35 U.S.C. §§ 271, 281, 283-285, among others. This Court has subject matter jurisdiction of the action under 28 U.S.C. § 1331 and § 1338(a).

36. Upon information and belief, this Court has personal jurisdiction over Defendants, and venue is proper in this Court pursuant to 28 U.S.C. §§ 1391(b) & (c) and 1400 because, among other things, Defendants have established minimum contacts within the forum such that the exercise of jurisdiction over Defendants will not offend traditional notions of fair play and substantial justice. For example, Defendants have placed products and services that practice and/or embody the claimed inventions of the Asserted Patents into the stream of commerce with the knowledge and/or reasonable expectation that purchasers and users of such products were located within this district. In addition, Defendants have used, sold, advertised, marketed, and distributed products in this district that practice the claimed inventions of the Asserted Patents. Defendants derive substantial revenue from the sale of infringing products distributed within this district, and/or expect or should reasonably expect their actions to have consequences within this district, and derive substantial revenue from interstate and international commerce. Defendants have business offices in this District. Defendants maintain servers performing infringing acts within the United States.

37. Among other forum-targeted activities, the domain xvideos.com resolves to ServerStack, Inc. IP addresses within the range 185.88.181.2 through 185.88.181.11². These IP

² <https://mxtoolbox.com/SuperTool.aspx?action=a%3axvideos.com>

addresses are part of Autonomous System 46652, which is owned and operated by ServerStack, Inc.³. Similarly, the domain xnxx.com resolves to ServerStack, Inc. IP addresses within the range 185.88.181.53 through 185.88.181.60⁴. These IP addresses are also part of Autonomous System 46652, which is owned and operated by ServerStack, Inc.⁵. Server Stack, Inc. is a United States based company headquartered in New York, New York⁶.

38. Furthermore, Defendants contract with various Content Distribution Networks to distribute their video content in this District and in the United States. For example, xvideos.com video content is streamed from at least the domain hls-hw.xvideos-cdn.com⁷, which is owned by StackPath CDN and located within the United States,⁸ and cdn77-vid-mp4.xvideos-cdn.com⁹, which is owned by CDN77 and located within the United States¹⁰. Similarly, xnxx.com video content is streamed from at least the domain video-hw.xnxx-cdn.com¹¹, which is owned by Highwinds CDN and located within the United States¹² and cdn77-vid-mp4.xnxx-cdn.com¹³, which is owned by CDN77 and located within the United States.¹⁴

39. Defendants expressly and purposefully aim their websites and activities at the United States.

³ <https://www.bigdatacloud.com/asn-lookup/46652>

⁴ <https://mxtoolbox.com/SuperTool.aspx?action=a%3axvideos.com>

⁵ <https://www.bigdatacloud.com/asn-lookup/46652>

⁶ <https://www.serverstack.com/contact-us.html> (“**Headquarters** ServerStack, 101 Avenue of the Americas, 10th Floor New York, NY 10013”)

⁷ https://www.xvideos.com/video66601793/mia_khalifa_-_jmac_helps_arab_nympho_quench_her_thirst_for_cock

⁸ <https://www.iplocationfinder.com/hls-hw.xvideos-cdn.com>

⁹ https://www.xvideos.com/video43665443/sorority_initiation_game_with_a_big_black_cock

¹⁰ <https://www.iplocationfinder.com/143.244.51.248>

¹¹ https://www.xnxx.com/video-15vz0vb1/hot_fitness_couple_hook_up_at_a_party

¹² <https://www.iplocationfinder.com/video-hw.xnxx-cdn.com>

¹³ https://www.xnxx.com/video-z8p6xad/step_son_fucks_big_ass_slutty_mom_cum_on_tits

¹⁴ <https://www.iplocationfinder.com/156.146.36.20>

40. Upon information and belief, in its CDN order forms and contracts, Defendants specifically selected the use of datacenters located in the United States (and, on information and belief, paid more for those additional United States data centers) to store and serve content ordered at xvideos.com and xnxx.com which enable better services for customers in the United States. Furthermore, CDN services allow the customers, such as Defendants, to control which country's customers can use the CDN service. For example, the CDN77 service order form requires CDN users, in this case the Defendants, to specifically select which servers including ones in Dallas Texas are to be included in the service.

41. The screenshot below is a sample order form for a CDN service that Defendants use for both its xvideos.com and xnxx.com websites showing the requirement of purposeful selection of CDNs. Note this is a sample order form and not Defendants' actual CDN selection.

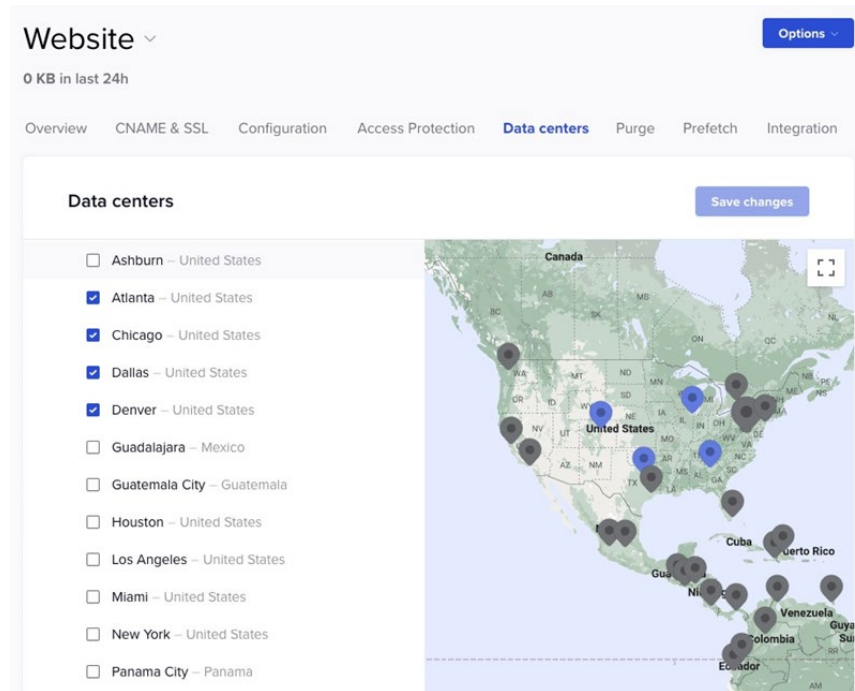

42. Furthermore, Defendants chose to allow United States customers to use the CDN service as the software gives control to the Defendants over the nationality of customers who have the ability to benefit and use the CDN service.

43. Defendants' servers targeted American customers to perform infringing acts in the United States by sending computer instructions into the jurisdiction directing users of the website to CDNs located in the United States.¹⁵ These computer instructions purposely direct United States customers to perform infringing acts within the United States.

```
{
  "@context": "https://schema.org",
  "@type": "VideoObject",
  "name": "egypt sex",
  "description": "egypt sex",
  "thumbnailUrl": ["https://cdn77-pic.xvideos-cdn.com/videos/thumbs16911/61/95"],
  "uploadDate": "2015-04-14T15:10:33+00:00",
  "duration": "PT00H04M11S",
  "contentUrl": "https://cdn77-vid-mp4.xvideos-cdn.com/DYZBGp4rXfxJu-fmYEuYkA",
  "interactionStatistic": {
    "@type": "InteractionCounter",
    "interactionType": { "@type": "WatchAction" },
    "userInteractionCount": 1437792
  }
}
```

44. Defendants chose to physically locate and/or operate the Accused Systems,¹⁶ as defined in and/or from locations within the United States. IP addresses associated with xvideos.com are located on servers physically in the United States and/or on servers controlled from the United States, as exemplified in the DNSDumpster.com images for xvideos.com excerpted below. The same is true for IP addresses associated with xnxx.com, as exemplified in the DNSDumpster.com images for xnxx.com excerpted below. The claimed inventions, among other things, pertain to a system comprising the following software components: Indexing Server, Browser, Archive Server, Tertiary Storage Manager, and Method Player.¹⁷ Infringing components

¹⁵ Screenshot below shows CDN77 scripts sent to a user.

¹⁶ The Accused Systems, as used herein, are the infringing Defendants systems, articles, and methods include, but are not limited to, systems, articles, and methods relating to the cataloguing, organizing, searching, rating, and provisioning of digital multimedia data, including but not limited to Defendants' software and hardware supporting various Internet websites for streaming video, and related home and mobile device specific applications, including as set forth in Plaintiff's forthcoming infringement contentions and any amendments thereto.

¹⁷ See, e.g., claims 1 and 19 of the '014 Patent.

of the Accused System(s) are run on computers that are either (1) physically located in the United States or (2) managed and controlled from locations within the United States.

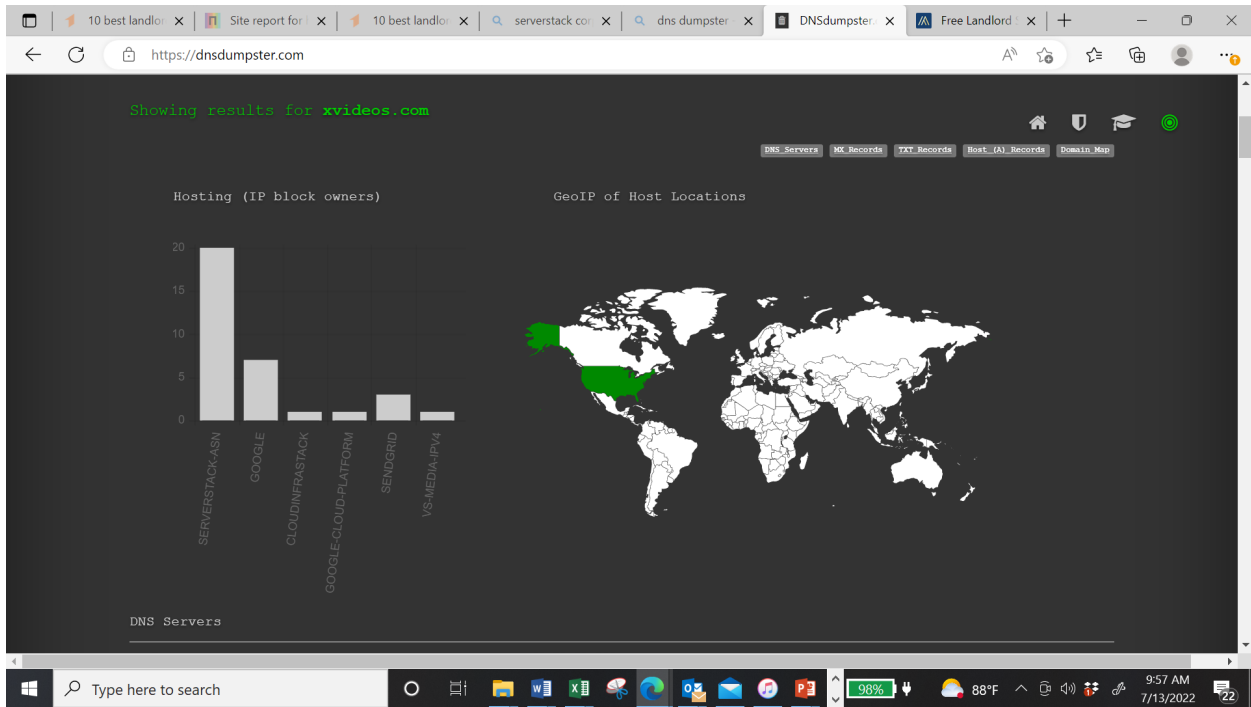

The screenshot shows the DNS records for xvideos.com. The records are as follows:

Record Type	Host	IP Address	AS/Company	Location
NS Records	ns5.randomserver.com.	69.55.52.220	SERVERSTACK-ASN	United States
	ns3.randomserver.com.	69.55.53.25	SERVERSTACK-ASN	United States
	ns2.randomserver.com.	69.55.52.7	SERVERSTACK-ASN	United States
	ns6.randomserver.com.	69.55.50.20	SERVERSTACK-ASN	United States
	ns1.randomserver.com.	69.55.48.186	SERVERSTACK-ASN	United States
	ns4.randomserver.com.	69.55.53.26	SERVERSTACK-ASN	United States
MX Records	10 aspmx2.googlemail.com.	209.85.202.27	GOOGLE	United States
	10 aspmx3.googlemail.com.	64.233.184.26	GOOGLE	United States
	10 aspmx4.googlemail.com.	142.250.27.26	GOOGLE	United States
	10 aspmx5.googlemail.com.	142.250.153.27	GOOGLE	United States

10 aspmx5.googlemail.com. 142.250.153.27 ea-in-f27.1e100.net GOOGLE United States

1 aspmx.l.google.com. 142.251.16.27 bl-in-f27.1e100.net GOOGLE United States

5 alt1.aspmx.l.google.com. 209.85.202.26 dg-in-f26.1e100.net GOOGLE United States

5 alt2.aspmx.l.google.com. 64.233.184.27 wa-in-f27.1e100.net GOOGLE United States

TXT Records ** Find more hosts in Sender Policy Framework (SPF) configurations

"v=spf1 mx ip4:141.0.172.202/32 ip4:69.55.53.149/32 ip4:69.55.53.150/32 ip4:141.0.172.99/26 ip4:141.0.168.58/32 ip4:69.55.57.146/32 ip4:69.55.53.235/32 include:_spf.google.com include:sendgrid.net include:spf.dynect.net ~all"

"google-site-verification=AaQKS4MdhV6EpISaPwBtdUOlvf79g3Wx5QxzTl1ECQ"

Host Records (A) ** this data may not be current as it uses a static database (updated monthly)

xvideos.com 185.88.181.2 SERVERSTACK-ASN United States

face-rec.xvideos.com 185.120.69.181 CLOUDINFRASTACK Czechia

static.xvideos.com 69.55.53.172 SERVERSTACK-ASN United States

HTTP: nginx
HTTPS: nginx

static-dev-xvlive.xvideos.com 35.231.218.115 115.218.231.35.bc.googleusercontent.com GOOGLE-CLOUD-PLATFORM United States

o1.mailing.xvideos.com 208.117.57.109 dhtrpsd.outbound-mail.sendgrid.net SENDGRID United States

blog.xvideos.com 185.88.181.7 SERVERSTACK-ASN United States

o2.sg.xvideos.com 168.245.124.7 o2.sg.xvideos.com SENDGRID United States

mail.xvideos.com 141.0.172.202 mail.randomserver.com SERVERSTACK-ASN Netherlands

control.xvideos.com 69.55.57.146 support.xnxx.com SERVERSTACK-ASN United States

trade-admin.xvideos.com 69.55.57.147 SERVERSTACK-ASN United States

chat-group-test-connection.xvideos.com 141.0.171.198 SERVERSTACK-ASN United States

The screenshot shows a web browser window with the URL <https://dnsdumpster.com>. The page displays a list of DNS records for various domains under the xvideos.com umbrella. Each record includes the domain name, IP address, and associated AS (Autonomous System) information. The records are as follows:

Domain	IP Address	AS Name	Location
chat-group-test-master.xvideos.com	141.0.168.248	SERVERSTACK-ASN	United States
links.xvideos.com	141.0.175.10	SERVERSTACK-ASN	Netherlands
webmaster-tools.xvideos.com	141.0.168.57	SERVERSTACK-ASN	United States
cams.xvideos.com	204.8.234.243	VS-MEDIA-IPV4	United States
ol.sg.news.xvideos.com	168.245.121.65	SENDGRID	United States
links.news.xvideos.com	141.0.175.10	SERVERSTACK-ASN	Netherlands

Each record also includes technical details such as HTTP (nginx), SSH (SSH-2.0-OpenSSH_7.4), and HTTP TECH (nginx).

The screenshot shows the same web browser window, but now displaying a network graph. The graph visualizes the relationships between various domains and their IP addresses. Below the graph, there are two buttons: "Download .xlsx of Hosts" and "View Graph (beta)".

Mapping the domain ** click for full size image

The graph shows nodes for domains like support.xvideos.com, mail.support.xvideos.com, upload-test-docker-new.xvideos.com, and chat-group-test-master.xvideos.com, connected to their respective IP addresses and AS information.

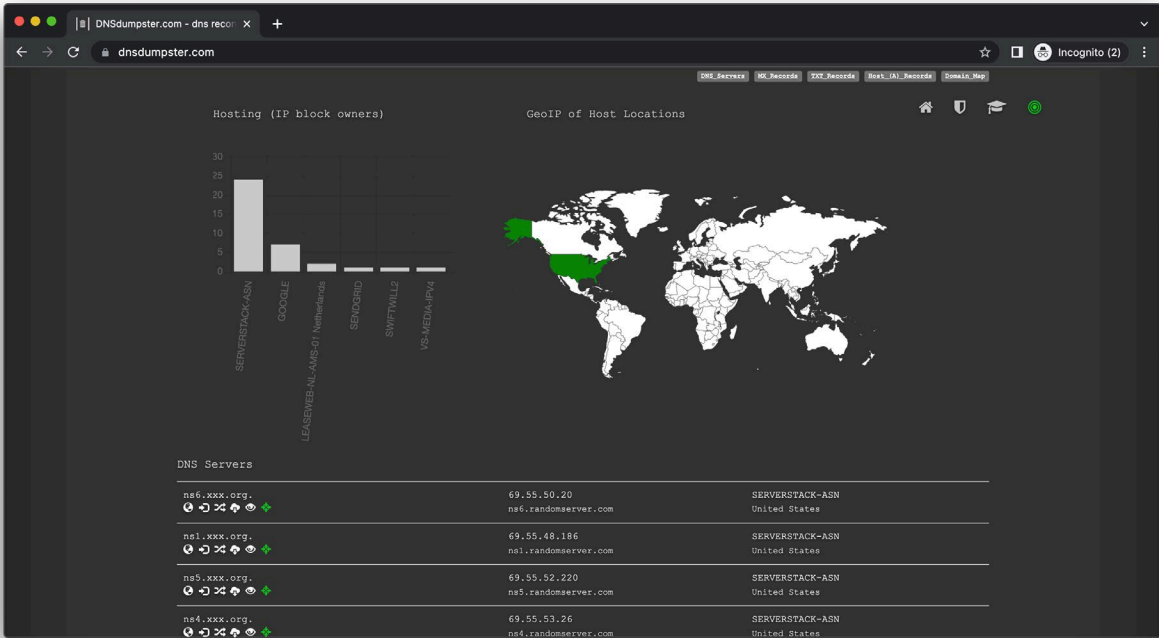

DNS Servers

Server	IP	Hoster	Location
ns6.xxx.org	69.55.50.20	SERVERSTACK-ASN	United States
ns1.xxx.org	69.55.48.186	SERVERSTACK-ASN	United States
ns5.xxx.org	69.55.52.220	SERVERSTACK-ASN	United States
ns4.xxx.org	69.55.53.26	SERVERSTACK-ASN	United States
ns2.xxx.org	69.55.52.7	SERVERSTACK-ASN	United States
ns3.xxx.org	69.55.53.25	SERVERSTACK-ASN	United States

MX Records ** This is where email for the domain goes...

Priority	Record	IP	Hoster	Location
20	alt1.aspmx.l.google.com.	209.85.202.27	GOOGLE	United States
20	alt2.aspmx.l.google.com.	64.233.184.26	GOOGLE	United States
30	aspmx2.googlemail.com.	209.85.202.26	GOOGLE	United States
30	aspmx3.googlemail.com.	64.233.184.26	GOOGLE	United States
30	aspmx4.googlemail.com.	142.250.27.27	GOOGLE	United States
30	aspmx5.googlemail.com.	142.250.153.26	GOOGLE	United States

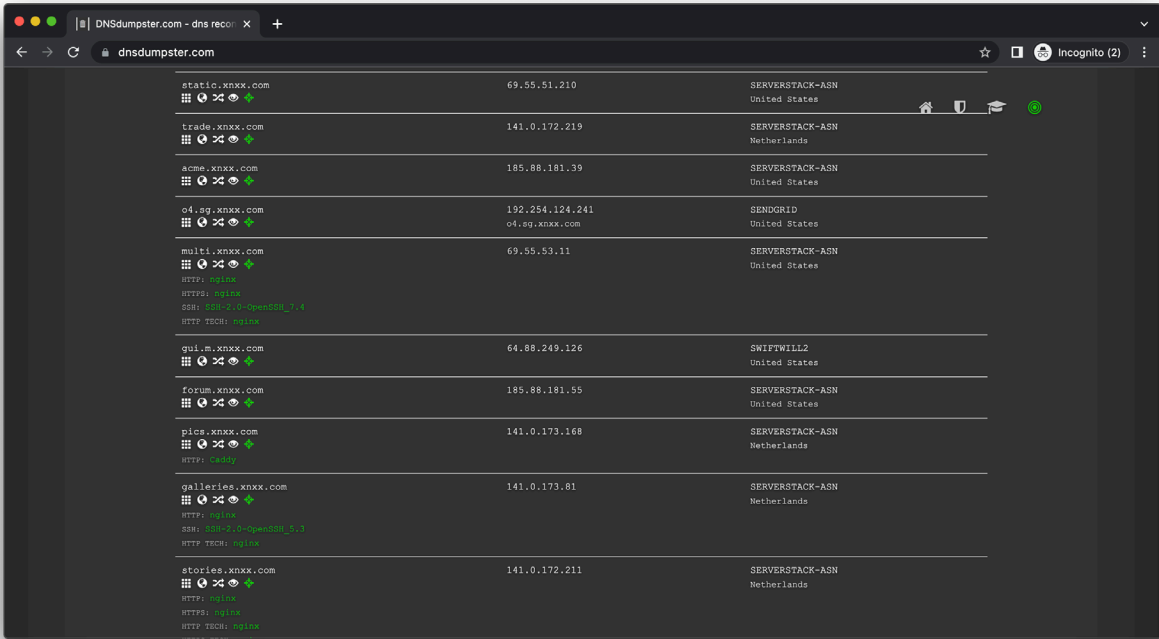
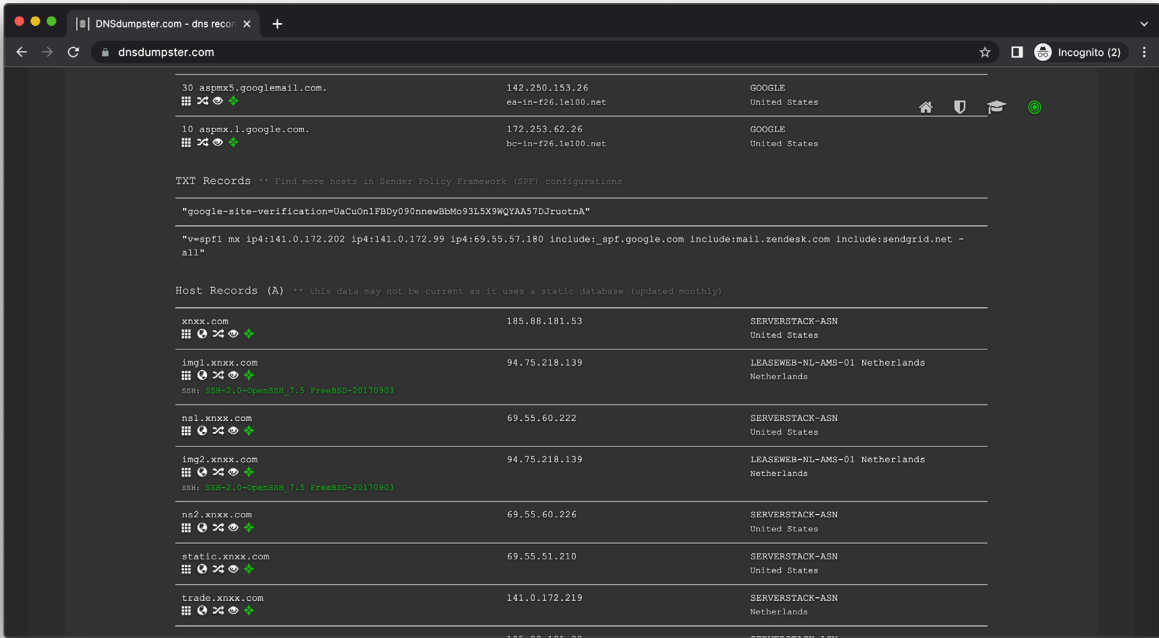

Domain	IP Address	ASN
jokee.xnxx.com	141.0.172.211	SERVERSTACK-ASN Netherlands
links.xnxx.com	141.0.172.10	SERVERSTACK-ASN Netherlands
cams.xnxx.com	204.8.234.242	V5-MEDIA-IPV4 United States
poems.xnxx.com	141.0.172.211	SERVERSTACK-ASN Netherlands
videos.xnxx.com	69.55.53.6	SERVERSTACK-ASN United States
checkout.xnxx.com	141.0.172.122	SERVERSTACK-ASN Netherlands
rev.xnxx.com	69.55.52.228	SERVERSTACK-ASN United States
proxy.xnxx.com	69.55.52.228	SERVERSTACK-ASN United States

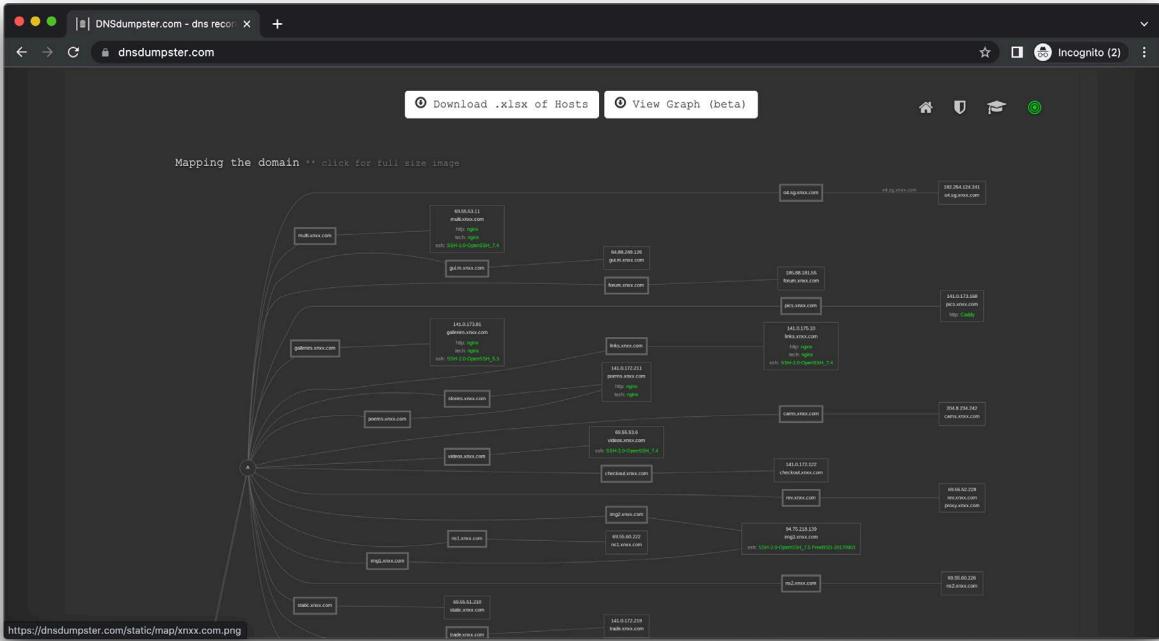

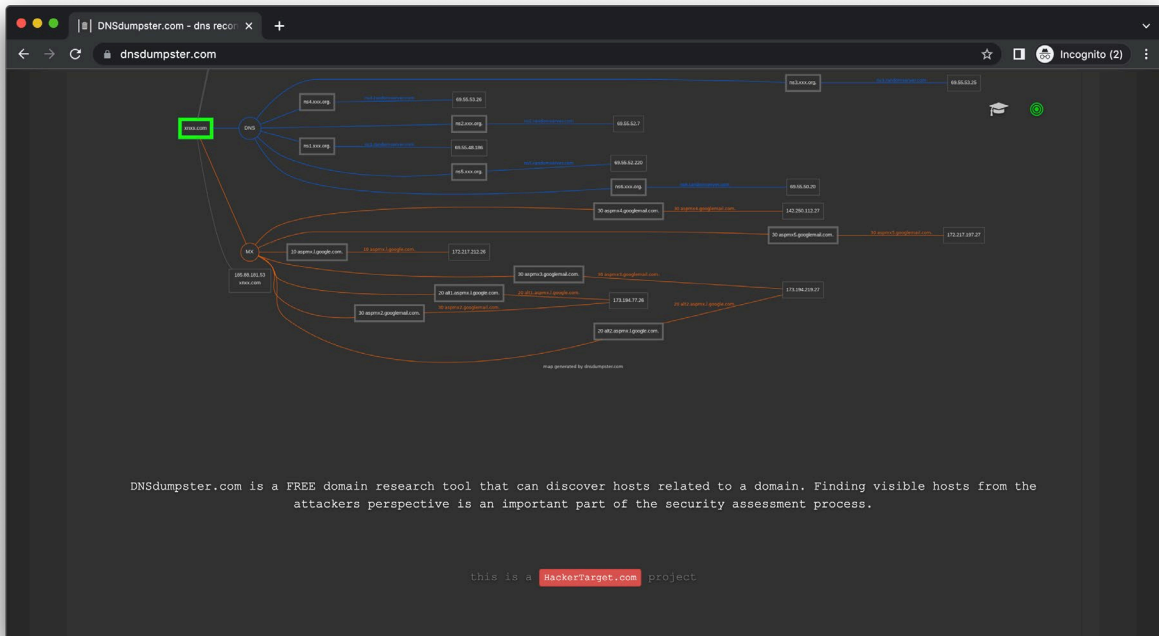

45. The vast majority of servers associated with the Accused Websites are located within the United States. Upon information and belief, the few servers located outside the United States (e.g., Amsterdam) are operated from the United States. Defendants entered into an “active services agreement with United States company Serverstack which later was purchased by DigitalOcean, both of which have the same principal place of business at 101 Avenue of the Americas, 10th floor, New York, New York, 10013. Serverstack has no other offices located outside the United States.

46. Upon information and belief, Serverstack/Digital Ocean provides some the servers that run the “host/browser” accused software of the claimed invention. Although at least some of the host browser/servers are located in the Netherlands, Serverstack/DigitalOcean personnel remotely control the servers running the XVideos website and XNXX website in the Netherlands

from its United States offices and locations.¹⁸ Upon information and belief, the management services for the XVideos and XNXX websites provided by Server Stack/Digital Ocean included: (1) developing a full-service infrastructure, (2) analyzing content, (3) indexing and categorizing data, (4) developing and offering content to assist advertisers, and (5) sophisticated software development.

47. ServerStack, through Digital Ocean, actively manages the XVideos and XNXX websites. Without this active management, XVideos and XNXX would routinely stop functioning. In other words, upon information and belief, ServerStack, through DigitalOcean, does not operate as a stagnant server host, instead, they must actively review and understand the content so that they can scale the website as a whole, including changing the quality of video uploads to maintain loading times and speed of searching, understanding terms that are being searched for so that advertisements are appropriately worded, placed and are successful to generate additional revenue.

48. Requests to remove content from at least the XVideo and XNXX websites are sent to abuse@serverstack.com, which indicates a United States location.¹⁹

49. Defendants' appeals to, profits from, and exploits the United States market for commercial gain.

50. Various companies are subsidiary content creation companies of Defendants, including for example Penthouse World Media LLC, Penthouse World Broadcasting LLC; Penthouse World Digital LLC; Penthouse World Licensing LLC; and Penthouse World Publishing LLC, VS Media, Inc., NKL Associates, s.r.o.

¹⁸ *Doe v. WebGroup Czech Republic*, Case No. 2:21-cv-02428-VAP-SK, Doc. 122-1. Seifert Decl. ¶ 16.

¹⁹ <https://mxtoolbox.com/SuperTool.aspx?action=mx%3aserverstack.com&run=toolpage>

51. Defendants' business model targets United States residents for content made in the United States and actors for its various United States subsidiary content creation companies. WGCZ harvests the data of users to determine a country of origin and then tailors the content related to that country to specifically appeal to United States customers.²⁰

52. Defendants require users with an account to identify the country of origin. XVideos also attempts to guess the country of the user by using the IP address. *See* xvideos.com, including viewing HTML source code for the homepage.

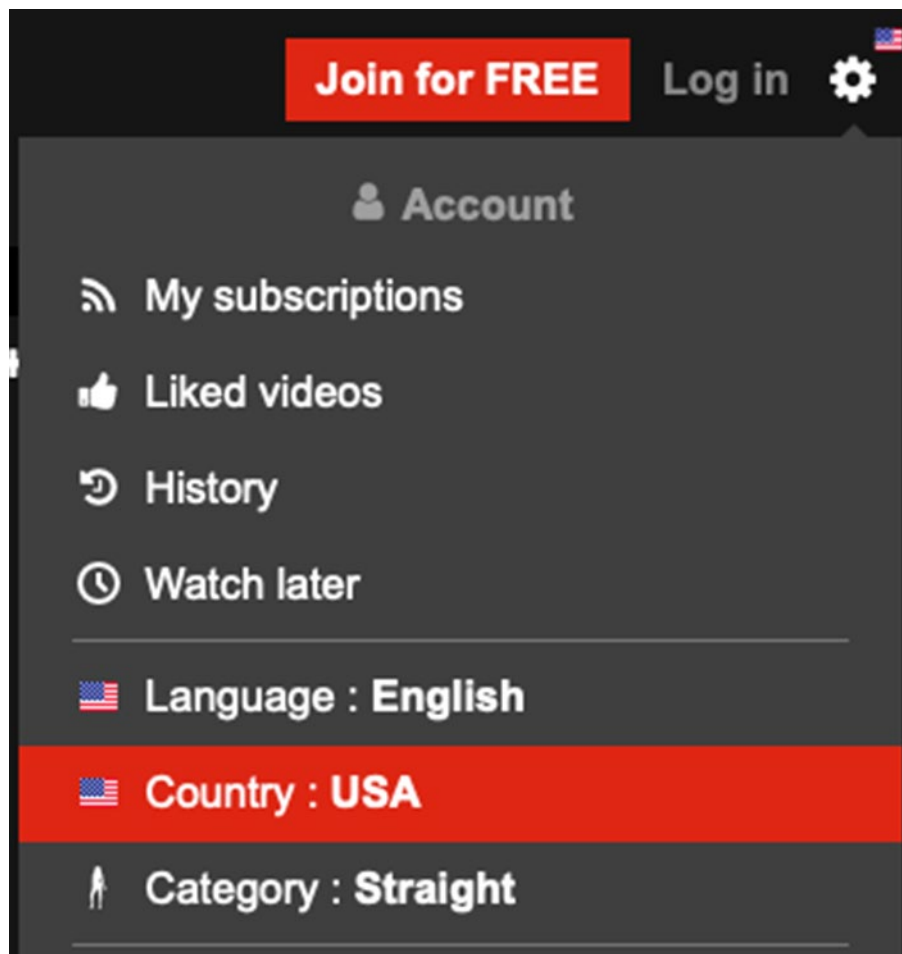

```
"gentime":1656005030,"ip":"38.81.106.136","country":"US","lazyloading":true,
```

²⁰ <https://info.xvideos.com/legal/privacy>

53. Defendant's XNXX.com website does the same. *See* xnxx.com, including viewing HTML source code for the homepage.

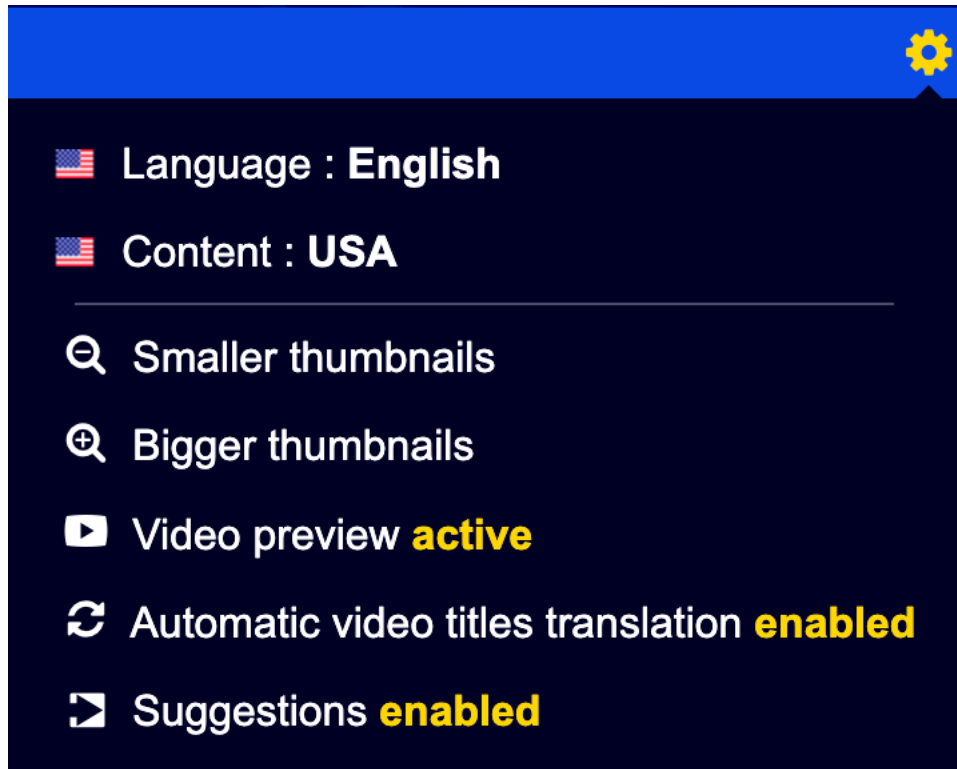

```
"gentime":1659125225,"ip":"38.81.106.136","country":"US",
```

54. Defendants specifically tailor the video content of the website to appeal to the country of origin by emphasizing videos related to that country in their search and recommendation features. For example, Defendants customize the content displayed on the homepage of both xvideos.com and xnxx.com based upon the geographic location of its websites' visitors, including through the display and promotion of specific content to users within the United States.

55. For example, Defendant's websites xvideos.com and xnxx.com attempt to determine the geographic location of its websites' visitors²¹. Based upon this geographical information, which may also be manually overridden by a user, Defendants customize the content included on their homepages and within search results in order to promote country-specific content. For example, when "Country" is changed from "USA" (based upon the visitors IP Address), to "Nigeria" or "Korea", the content displayed on the homepage is customized accordingly.

56. To support and benefit from United States users Defendants advertise porn acting jobs for its United States subsidiaries that make porn in the United States to be distributed to customers in the United States.

57. A link to "Become a porn model" is located in the footer of the homage page for both xvideos.com and xnxx.com. In both instances the link forwards to the website porn.work/en/ The link specifically states that the content from its US subsidiaries (including but not limited to, Penthouse Magazine, BangBros, Private, PornWorld, PornBox, Legal Porno, Giorgio Grandi, Girlfriends Films, Girls Gone Wild , XNXX Gold, XVIDEOS Red, DDF Network, Gonzo, American Anal, Dancing Bear, Haze Her, My GF, Busty Adventures, Haze Him, Rub Him, Thug Hunter, College Rules) will be "featured and streamed on the most visited adult porn tubes on the planet such as XVideos and Xnxx!" See <https://porn.work/en/>, linked to

²¹ When a user does not manually override their country of origin, then Javascript setting "forcedcountry" embedded in the HTML of the xvideos.com homepage is set to false. When a user overrides this setting (e.g., by setting "Country" equal to "Japan" the "forcedcountry" parameter is set to "JP" and videos and/or advertisements directed to Japanese users are promoted on the websites homepage.

by

xvideos.com

and

xnxx.com

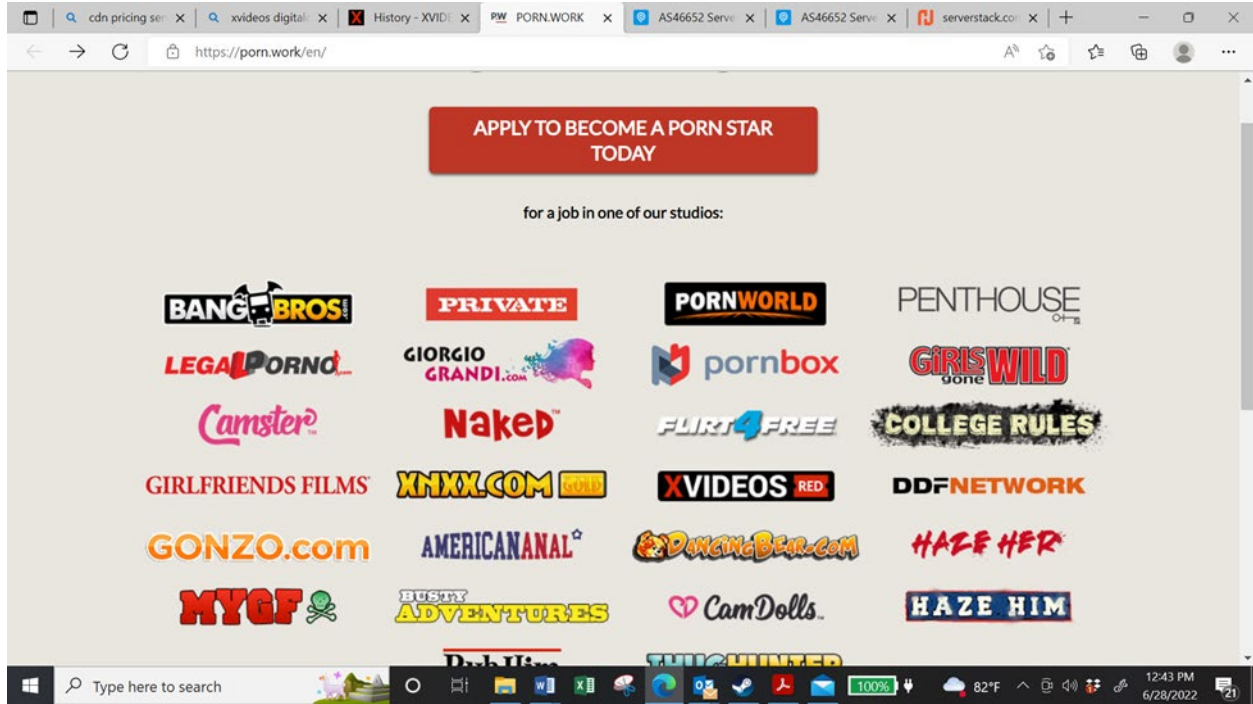

MYGF **BUSTY ADVENTURES** **CamDolls** **HAZE HIM**
Rub Him **THUGHUNTER**

XXX JOBS FOR ADULTS

Would you want to **work in the adult industry, be your own boss, and make LOADS of money?**

You can jumpstart your career and become an adult movie actor/actress (so called "porn star") or a cam boy/girl for the biggest brands in adult entertainment!

We're so excited for you to start your modeling experience on our network and we'll stay committed to helping you find success online. Become part of our vast studio network such as Penthouse Magazine, BangBros, Private, PornWorld, PornBox, Legal Porno, Giorgio Grandi, Girlfriends Films, Girls Gone Wild, XNXX Gold, XVIDEOS Red, DDF Network, Gonzo, American Anal, Dancing Bear, Haze Her, My GF, Busty Adventures, Haze Him, Rub Him, Thug Hunter, College Rules and have your videos featured and streamed on the most visited adult porn tubes on the planet such as XVideos and Xnxx! You can also become a camgirls in one of the world famous cam site Naked, Flirt4Free, Cam Dolls and Camster.

Apply Now

© 2022 Porn Work

XVIDEOS INFORMATION AND LINKS

Sections: [Shortcuts](#), [Information](#), [Support](#), [Feeds](#), [External links](#), [Legal stuff](#)

SHORTCUTS

[UPLOAD VIDEOS](#)

[XVIDEOS RED](#)

NEW [DOWNLOAD THE XVIDEOS APP](#)

[CAM MODEL SIGNUP](#)

INFORMATION

[CONTENT PROGRAM](#)

NEW [ACCOUNT STATUS](#)

[CONTENT PROTECTION](#)

[CONTENT REMOVAL](#)

[PARENTAL CONTROL](#)

[UNDERAGE CONTENT CONTROL](#)

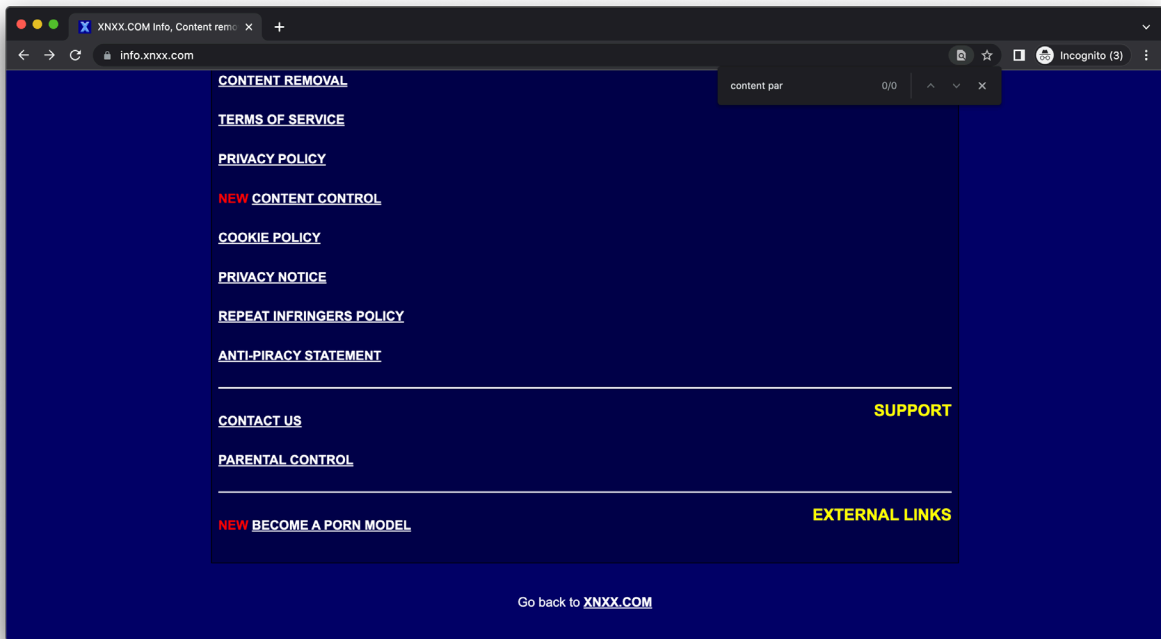
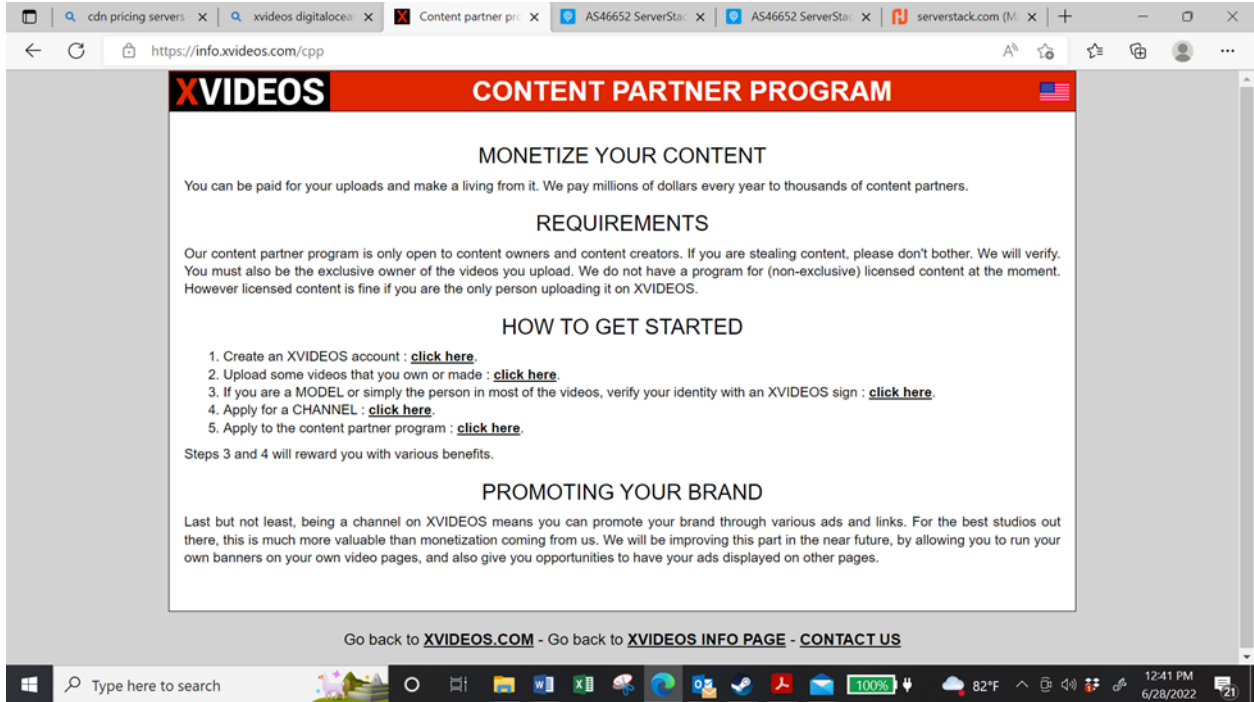

58. Defendants have entered into thousands of content partner contracts with U.S. citizens to acquire content to be uploaded, catalogue and displayed by the infringing systems to

U.S. customers. The content partner program offers the pornographer various methods to upload content and create revenue based on views. From the XVideos site, a user can select the WGCZ-created link for “RED videos,” XVideos premium content, and various “channels” hosting WGCZ-controlled content, including from content partners. To join the content partner program, a user must create an XVideos account (which requires only a valid email address), “verify” the account, and then set up a “channel” by uploading three or more videos.⁴⁰

59. Xvideos.com ranks as the 11th most popular website in the United States and the most popular adult website.²² XVideos and Xnxx together are visited over 5 billion times a month, which is double the traffic of their biggest competitor, Pornhub. The United States is by far the largest national market for Xnxx and XVideos. Approximately 19-24% of Xnxx’s website traffic and 19% of XVideos’s website traffic comes from the United States. Comparing these numbers worldwide, the United States accounts for five times more traffic on Xnxx than the second largest national market (Russia), and three times more traffic on XVideos than the second largest national market (Japan).

60. Defendants seek protection under United States law by complying with the Digital Millennium Copyright Act (“DMCA”) qualifying the Accused Websites for certain safe harbor defenses to copyright infringement claims. Defendants notify users of the website’s policies in accordance with the DMCA in the terms of service.²³

61. Defendants avail themselves of the United States jurisdiction by enjoying the protection of United States laws.

²² <https://www.similarweb.com/top-websites/united-states/>

²³ <https://info.xvideos.com/takedown>; <https://info.xnxx.com/takedown>

62. Defendants seek protection under United States law by entering into binding contracts with United States citizens to indemnify XVideos for any litigation that may arise from an uploaded video.²⁴

63. Defendants provide links explaining United States child pornography law and reporting. The links are uniquely directed to United States customers and content partners. They have no other purpose than to instruct United States citizens on the law of this jurisdiction when using Defendants' website:²⁵

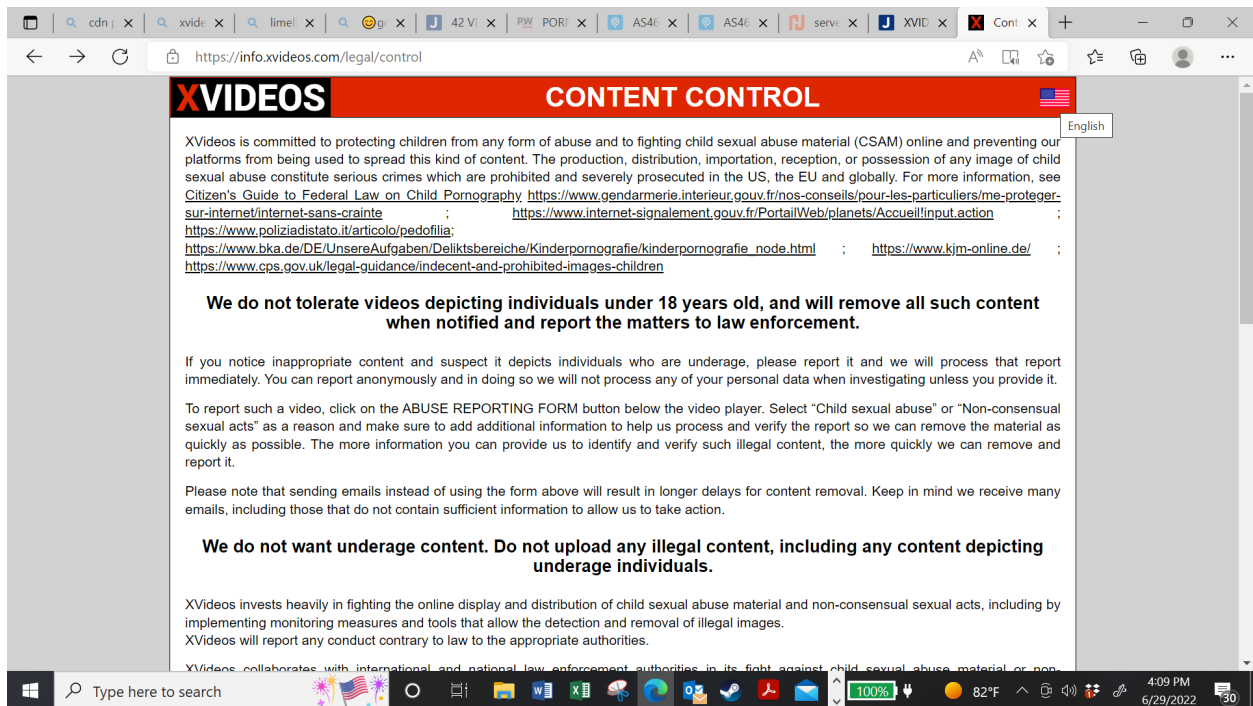

64. The links above from the website resolve at this document:

²⁴ <https://info.xvideos.com/legal/tos/>; <https://info.xnxx.com/legal/tos>

²⁵ <https://info.xvideos.com/legal/control/>; <https://info.xnxx.com/legal/control>

65. Defendants seek protection of United States laws by registering trademarks. The trademarks for ‘XVIDEOS’ and ‘XVIDEOS RED’ are owned by WebGroup Czech Republic, and the trademark for ‘XNXX’ is owned by NKL.²⁶

66. Defendants also seek protection of United States laws by participating in the administrative procedures of the Digital Millennium Copyright Act’s safe harbor provision. XVIDEOS avails themselves of the “take down” safe harbor provisions by appointing a DMCA agent and instituting the required take down procedures:

“In compliance with the DMCA, we only accept copyright infringement takedown notices from content owners or someone officially authorized to act on their behalf. To read more about the requirements of a complete notice, we invite you to visit <https://www.dmca.com/faq/What-is-a-DMCA-Takedown>, and consult with your own counsel.”

²⁶ <https://tmsearch.uspto.gov/bin/showfield?f=doc&state=4806:oijd09.3.1>;
<https://tmsearch.uspto.gov/bin/showfield?f=doc&state=4806:oijd09.3.2>;
<https://tmsearch.uspto.gov/bin/showfield?f=doc&state=4806:oijd09.2.4>

67. Defendants also tailors its advertising to the United States. Defendants use geofencing and location-based advertising (i.e., “targeted” advertising) to generate additional revenue from their websites’ users, and thereby directly profit from that advertising specifically targeted at the United States. Defendants use their own corporate affiliate, Traffic Factory, as the advertising agency for the targeted advertising on their websites, including the targeted advertising in the United States and the collection of data from United States consumers.²⁷

68. Upon information and belief, Defendants’ contract with United States entities Google and Twillio to manage user emails to communicate with the site, and PayPal and EPOCH to manage payments (in USD) to/from users and advertisers. xvideos.com contact links explicitly directs US customers to use a US mail server when contacting them.

69. Defendants place a United States flag on xvideos.com and xnxx.com pages to appeal to users located within the United States. There is no other purpose for these marketing efforts other than to appeal to the United States:

²⁷ *Doe v. WebGroup Czech Republic*, Case No. 2:21-cv-02428-VAP-SK, Doc. 122-1. Seifert Decl. ¶ 19.

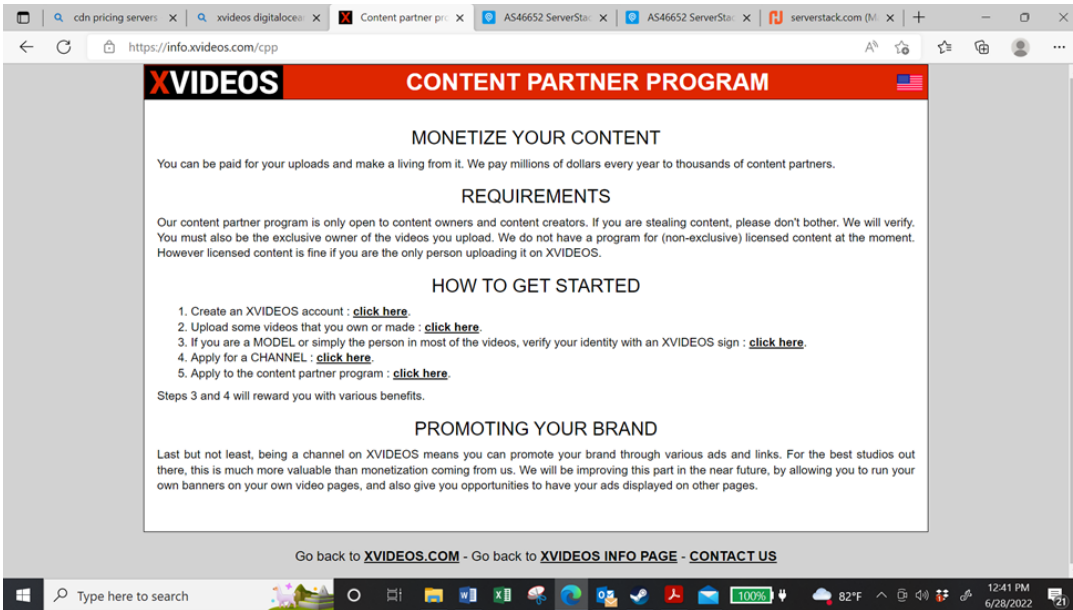
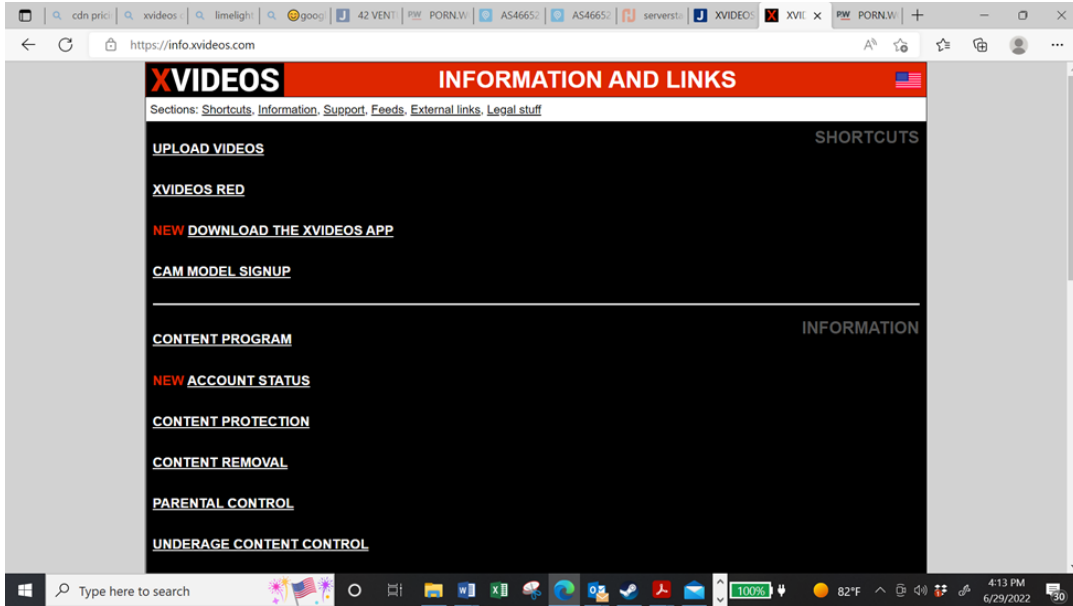

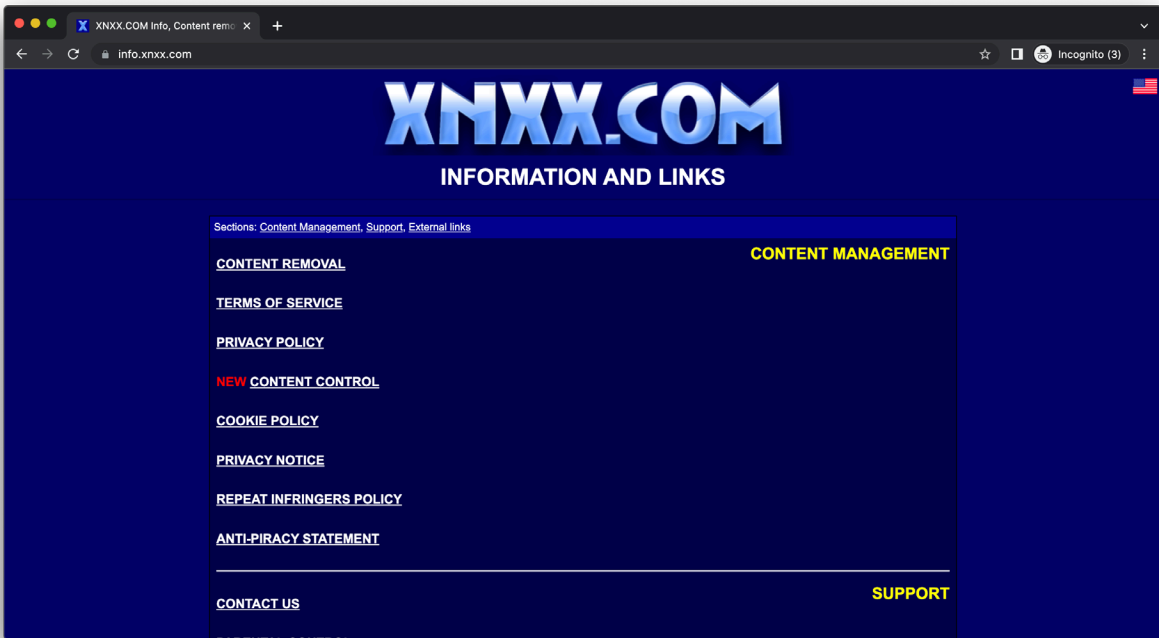

70. Defendants own and control Penthouse World Media LLC; Penthouse World Broadcasting LLC; Penthouse World Digital LLC; Penthouse World Licensing LLC; and Penthouse World Publishing LLC (“the Penthouse Entities”). The Penthouse Entities are located

at 8944 Mason Ave, Chatsworth, California 91311 and their manager/member is Robert Seifert, who is also a WGCZ executive.

71. On information and belief, until at least 2020, one or more of the Defendants owned and controlled VS Media, Inc., located at 31416 Agoura Rd, Westlake Village, CA 91361. VS Media, Inc. manages, operates and controls an XVideos enterprise webcam model domain/platform, available on the web at cams.xvideos.com, connected to the XVideos infrastructure from their California headquarters.²⁸ In this regard, XVideos directs users, loaders, viewers, or otherwise anyone interested in becoming an “XVideos webcam model” to the California VS Media team stating, “Once you click submit, a member of our Los Angeles-based staff will contact you to help you complete the setup process for new live cam models.”²⁹ Defendants invite anyone with questions to reach out to the XVideos “broadcast support team at broadcastsupport@vsmedia.com.”

72. On information and belief, in May 2020, Defendant’s executives formed WorldWeb Services, s.r.o., a Czech company, for the purpose of owning VS Media, Inc, a U.S. entity. WorldWeb Services, s.r.o., was opened by Robert William Seifert, who, on information and belief, is a confidant of the Pacauds and the enterprise director, operator, and/or executive of XVideos.³⁰ The registered address for WorldWeb Services, s.r.o. is again, with a place of business at Krakovská 1366/25, Nové Město, 110 00 Prague.

73. The website cams.xvideos.com is owned and operated by HC Multimedia, LLC based in Nevada³¹. The webserver hosting this website is located at the IP address

²⁸ See, https://www.xvideos-cams.com/broadcasters.php?tracker=xv_info_external

²⁹ *Id.*

³⁰ See, <https://or.justice.cz/ias/ui/vypis-sl-detail?dokument=62142157&subjektId=1088341&spis=1220047>

³¹ <https://cams.xvideos.com/>

204.8.234.243³². This server is located within California³³. The domain vxcams.com is a nearly identical website, also owned and operated by HC Multimedia, LLC based in Nevada³⁴. The webserver hosting this website is located at the IP address 204.8.234.160³⁵. This server is located within California³⁶. Furthermore, the website cams.xnxx.com is owned and operated by HC Multimedia, LLC based in Nevada³⁷. The webserver hosting this website is located at the IP address 204.8.234.242³⁸. This server is located within California³⁹.

74. As set forth in the preceding section, the Defendants act as the alter ego of their subsidiaries, “related parties”, U.S. entities, and foreign counterparts and together act as a website enterprise under common control with integrated business resources in pursuit of a single business purpose.

75. Venue properly lies in this district under the provisions of 28 U.S.C. § 1391(b), (c) and 1400 because Defendants are foreign corporations not incorporated in the United States and have committed acts within this judicial district giving rise to this action, and Defendants continue to conduct business in this judicial district, including one or more acts of selling, using, importing and/or offering for sale infringing products or providing service and support to Defendants’ customers in this District.

IV. PLAINTIFF’S PATENTS

76. On September 22, 1998, United States Patent No. 5,813,014 (“the ’014 Patent”) was duly and legally issued for a “Method and Apparatus for Management of Multimedia Assets.”

³² <https://mxtoolbox.com/SuperTool.aspx?action=a%3axvideos.com>

³³ <https://www.iplocationfinder.com/204.8.234.243>

³⁴ <https://www.vxcams.com/>

³⁵ <https://mxtoolbox.com/SuperTool.aspx?action=a%3avxcams.com>

³⁶ <https://www.iplocationfinder.com/204.8.234.160>

³⁷ <https://cams.xnxx.com/>

³⁸ <https://mxtoolbox.com/SuperTool.aspx?action=a%3acams.xnxx.com>

³⁹ <https://www.iplocationfinder.com/204.8.234.242>

The invention disclosed by the '014 Patent relates to a multimedia system including components that allow input, information retrieval, and display. The claims of the '014 Patent cover, by way of example only, a method of accessing multimedia data comprising the steps of defining a catalogue, specifying a search request, identifying a result, retrieving a portion of multimedia data, storing the search request, and storing the search result.

77. On November 3, 1998, United States Patent No. 5,832,499 (“the '499 Patent”) was duly and legally issued for a “Digital Library System.” The invention disclosed by the '499 Patent relates to a digital library system to capture, access, manage, and distribute multimedia data. The claims of the '499 Patent cover, by way of example only, a digital library system comprising a data capture system, an access management system, and a distribution system.

78. On July 18, 2000, United States Patent No. 6,092,080 (“the '080 Patent”) was duly and legally issued for a “Digital Library System.” The invention disclosed by the '080 Patent relates to a digital library system that includes systems and mechanisms for capturing, managing, and distributing multimedia data. The claims of the '080 Patent cover, by way of example only, a digital library system comprising a cataloging system, an access management system, and a distribution system.

79. On March 5, 2002, United States Patent No. 6,353,831 (“the '831 Patent”) was duly and legally issued for a “Digital Library System.” The invention disclosed by the '831 Patent relates to a digital library system that includes systems and mechanisms for capturing, managing, and distributing multimedia data. The claims of the '831 Patent cover, by way of example only, a digital library system comprising a means for cataloguing multimedia data, a means for managing access, and a means for distributing.

80. On November 3, 1998, United States Patent No. 5,832,495 (“the ’495 Patent”) was duly and legally issued for a “Method and Apparatus for Cataloguing Multimedia Data.” The invention disclosed by the ’495 Patent relates to cataloguing of data such as multimedia data. It comprises a catalog including one or more catalog elements, each of which has one or more attributes. The claims of the ’495 Patent cover, by way of example only, a method of cataloguing comprising creating a catalogue, specifying a description, creating a catalogue element, and creating a point to at least one keyword.

81. On November 5, 2002, United States Patent No. 6,477,537 (“the ’537 Patent”) was duly and legally issued for a “Method and Apparatus for Management of Multimedia Assets.” The invention disclosed by the ’537 Patent relates to a multimedia system including components that allow input, information retrieval, and display. The claims of the ’537 Patent cover, by way of example only, an application program interface (API) comprising API protocol means comprising a command interface between a first system component and an additional system component comprising means for selecting multimedia data, means for retrieving multimedia data, and means for displaying multimedia data.

82. On March 6, 2001, United States Patent No. 6,199,060 (“the ’060 Patent”) was duly and legally issued for a “Method and Apparatus for Management of Multimedia Assets.” The invention disclosed by the ’060 Patent relates to a multimedia system including components to allow input, information retrieval, and display. The claims of the ’060 Patent cover, by way of example only, a method of interfacing components in a multimedia system comprising defining a generalized protocol, invoking a search request, communicating between at least two components, returning a search response, invoking a retrieval request, and invoking a transmit request.

83. On April 3, 2001, United States Patent No. 6,212,527 (“the ’527 Patent”) was duly and legally issued for a “Method and Apparatus for Cataloging Multimedia Data.” The invention disclosed by the ’527 Patent relates to cataloging of data such as multimedia data. The claims of the ’527 Patent cover, by way of example only, a method of managing the quality of a data collection of multimedia data comprising reviewing multimedia data, creating a quality event, and associating the quality event with input data.

84. On April 15, 2003, United States Patent No. 6,549,911 (“the ’911 Patent”) was duly and legally issued for a “Method and Apparatus for Cataloging Multimedia Data.” The invention disclosed by the ’911 Patent relates to cataloging of data such as multimedia data. The claims of the ’911 Patent cover, by way of example only, a method of cataloging multimedia data comprising specifying a description, creating a catalogue element, creating a plurality of attributes and attribute elements, and creating a plurality of relationships.

85. On July 17, 2003, United States Patent No. 6,581,071 (“the ’071 Patent”) was duly and legally issued for a “Surveying System and Method.” The invention disclosed by the ’071 Patent relates to a survey system wherein multiple versions of a survey may be defined and data from the survey versions may be maintained as cohesive data. Each survey may comprise different sets of questions and different types of answers. The claims of the ’071 Patent cover, by way of example only, a survey method comprising obtaining a schema, obtaining a definition, and capturing responses.

86. On June 3, 2003, United States Patent No. 6,574,638 (“the ’638 Patent”) was duly and legally issued for a “Surveying System and Method.” The invention disclosed by the ’638 Patent relates to a survey system wherein multiple versions of a survey may be defined and data from the survey versions may be maintained as cohesive data. Each survey may comprise a

different set of questions and different types of answers. The claims of the '638 Patent cover, by way of example only, associating multimedia data with surveying data comprising obtaining an association, searching survey data, and identifying multimedia

V. HISTORY OF THE INVENTION

87. The Asserted Patents are currently owned by the University of Southern California and Preservation has obtained a license with all necessary rights from the Shoah Foundation of the University of Southern California (the “Shoah Foundation”) to enforce these patents against Defendants in its own name. The Asserted Patents are fully incorporated herein by reference with the same force and effect as if they were given in full text. In the mid-1990s, Steven Spielberg founded the Shoah Foundation to preserve the testimonies of the then living 50,000 holocaust survivors before their first-hand accounts of the Holocaust were lost as that generation passed away. The Shoah Foundation’s impetus was to gather, catalog, and make available for access thousands of video testimonies. In doing so, the Shoah Foundation sought to build one of the largest video libraries in the world comprising nearly 52,000 video testimonies in 32 languages from 56 countries.

88. In 1996, there was no multimedia system that could handle the large volume of video testimonies collected and maintained by the Shoah Foundation, so Samuel Gustman, CTO of the Shoah Foundation and an inventor of the Patents in Suit, set out to design one. Gustman created a multimedia distribution system that incorporated a unique distributed modular infrastructure and advanced techniques for indexing, accessing, distributing, and surveying multimedia data. Hundreds of researchers participated in the implementation of a working system over a multi-year period. It was important to the system was the need to interact and be compatible with various portals at 199 sites in 39 countries and 12 different languages.

89. Gustman eventually created a multimedia distribution system that incorporated a unique distributed modular infrastructure and advanced techniques for indexing, accessing, distributing, surveying multimedia data that was compatible with disparate technologies of multimedia components. The inventions underlying Gustman's system were captured in 11 U.S. patents that make up the Patents-in-Suit. Today, these inventions are used to enhance the consumer multimedia streaming experience in nearly every major internet company.

VI. OVERVIEW OF THE PATENTED TECHNOLOGY IN VIEW OF PATENT ELIGIBILITY UNDER 35 USC SECTION 101

90. The Asserted Patents and claims are not merely directed to the basic idea of a digital library, a card catalogue, or even a multimedia system. Rather, these patents reflect the Shoah Foundation's multi-year efforts involving hundreds of researchers to actually create and implement a well-functioning, large scale multimedia system across multiple platforms using nonconventional technology.

91. Early multimedia systems suffered from technical problems that were simply not present with brick and mortar document libraries and card catalogues such as:

1. Interoperability between components of differing platforms or computer systems;
2. Effective content-based searching of non-textual video material and the inability to search within a video;
3. Inadequate and inefficient data structures and system architectures;
4. Long query response times, prohibitive system processing consumption and bandwidth consumption.

92. The Patents-in-Suit describe **and claim** several specific technological improvements to address these real-life technical problems in early prior art multimedia delivery systems. These specific implementation features embody inventive concepts that were

unconventional for the time period and can be grouped into at least six categories of distinctly claimed non-abstract technological improvements:

1. The Distributed Architecture Claims for addressing compatibility and replacement problems associated with the closed architecture of early prior art multimedia systems;
2. The API Protocol Interface Claims for Interfacing Multimedia Components of a Distributed Architecture to address compatibility and inoperability problems;
3. The Catalogue Data Structure Claims for Searching Multimedia;
4. The Phrase Data Structure Claims for Searching within a Video;
5. The Search Query and Search Result Caching Claims for Preprocessing Search Results; and
6. The Video Caching Claims for Efficient Video Delivery

93. The essence of the inquiry into whether a claim is improperly directed into an abstract idea is whether the limitations as a whole are merely directed to a desired, but abstract, result or whether they specify a particular technological means to achieve such result, with the former being an improper abstract idea and the latter being a patent-eligible technological improvement. Importantly, the claimed solutions of the patents in suit are not merely directed to abstract results, but rather are directed to specific architectures, multimedia components, interfaces and protocols, data structures, processing steps and other features that represent non-abstract technical improvements that provide the technological means to achieve a solution to a technological problem. Similarly, the non-abstract improvements specified by the ordered combination of the claims also contain one or more non-conventional, non-routine and non-well understood inventive concepts that also confer patent eligibility.

A. Distributed Architecture Claims for Interoperability

94. At the time of invention, development of multimedia distribution systems was in its infancy. Transmission of video and multimedia over existing computer communication networks, including the Internet, struggled with bandwidth, system resource processing, and compatibility issues that impeded the development of early multimedia distribution systems. At the time of the patents in suit, multimedia protocols for transmission over the internet had not yet been developed. Indeed, in 1998, two years after the filing of the '014 Patent, researchers still recognized the need for development of multimedia protocols over the internet:

So the design of real-time protocols for multimedia networking becomes imperative before the multimedia age comes.

...

[T]he Internet is growing exponentially. The well established LAN and WAN technologies based on IP protocol suite connect bigger and bigger networks all over the world to the Internet. In fact, Internet has become the platform of most networking activities. **This is the primary reason to develop multimedia protocols over Internet.** Another benefit of running multimedia over IP is that users can have integrated data and multimedia service over one single network, without investing on another network hardware and building the interface between two networks.

Liu, Multimedia Over IP: RSVP, RTP, RTCP, RTSP, http://www.cse.wustl.edu/~jain/cis788-97/ftp/ip_multimedia/#multi1 (emphasis added).

Metasearch engines, which are gateway linking users to multiple and distributed search engines, would also benefit from a **multimedia archive description** scheme. The operation of current metasearch engines is **significantly restrained by the interface limitations of current search engines.**

U.S. Patent No. 6,941,325 titled “Multimedia archive description scheme” to Benitez et al. at 1:52-56 (emphasis added) (citing the '911 Patent as a reference).

95. As late as 2007, nearly a decade after the original filing date of the Patents-in-Suit, the wide spread use of proprietary protocols is described as a key obstacle to the distribution of video via the Internet and the development of non-proprietary protocols for multimedia is lauded as a significant advancement:

By the mid-2000s the vast majority of the Internet traffic was HTTP-based and content delivery networks (CDNs) were increasingly being used to ensure delivery of popular content to large audiences. Streaming media, **with its hodgepodge of proprietary protocols** - all mostly based on the far less popular UDP - suddenly found itself struggling to keep up with demand. **In 2007 a company named Move Networks introduced a technology and service that once again would change the industry: HTTP-based adaptive streaming.**

Instead of relying on proprietary streaming protocols and leaving users at the mercy of the internet bandwidth gods, Move Networks used the dominant HTTP protocol to deliver media in small file chunks while utilizing the player application to monitor download speeds and request chunks of varying quality (size) in response to changing network conditions. The technology had a huge impact because it allowed streaming media to be distributed far and wide using CDNs (over standard HTTP) and cached for efficiency, while at the same time eliminating annoying buffering and connectivity issues for customers.

Zambelli, A History of Media Streaming and the Future of Connected TV, available at <https://www.theguardian.com/media-network/media-network-blog/2013/mar/01/history-streaming-future-connected-tv> (emphasis added).

96. At the time of the filing of the Patents in Suit, the management and transmission of multimedia and video over wide scale networks, particularly the Internet, was not conventional or routine practice among generic computer systems. Special purpose computer software or hardware components that are not part of a generic computer programming, such as an indexing server, storage manager, or an archive server as well as media protocols, required to implement this functionality were just being developed or still in development in single component prior art systems.

i. The Distributed Architecture Claims Are Directed to Compatibility and Interchangeability Problems Caused by the Closed Architecture of Prior Art Multimedia Systems

97. The Distributed Architecture Claims provide a “particular arrangement” of server components (software and/or hardware) and data structures in a specific relational architecture that provides a solution to compatibility problems that were caused by the closed architecture of the then state of the art multimedia delivery systems—and they therefore represent non-abstract

technological improvements to existing prior art multimedia systems. The patent specification extensively details the problems with existing technology that its invention intended to address. Although a few basic, but limited, commercial multimedia systems were available in 1996, the available multimedia systems used a closed architecture that hardwired (by software design or physically) the various multimedia components and functions into a single multimedia component or proprietary system and ran on a single platform. These existing prior art multimedia management systems merged the functionality of a multimedia system into a single component, thereby making it impossible to separate the merged system into discrete components.⁴⁰ The patent specification criticizes prior art for its use of a closed architecture and proprietary interfaces that prevent interchangeability of multimedia components:

Current multimedia systems attempt to provide some... of the components described in FIG. 1A. However, the components provided by these systems are merged to form a single component **thereby making it impossible to separate the merged components into the discrete components described in FIG. 1A.**

'014 Patent, 1:39-43 (emphasis added).

[N]one of the systems provide viable options for each of the multimedia components identified in FIG. 1A. **All of the systems merge the components identified in FIG. 1A into a single, component** that makes it impossible to replace one of the components. Further, by combining the components into a single component, each system must run on a single hardware platform. Further, there is no vendor-independent interface available to integrate components from different vendors to construct a optimum multimedia system.

'014 Patent, 3:38-47 (emphasis added). The specification of the '014 Patent further describes several of these prior art systems and their deficiencies. It distinguishes the claimed invention from the prior art by criticizing the lack of separable multimedia components (software or hardware) and non-proprietary interfaces between the components:

A pre-packaged system having interconnected system components with **hardwired, proprietary interconnections is illustrated in FIG. 1F.** Such a

⁴⁰ Some of the available commercial multimedia management systems and their limitations and drawbacks are described in columns 1 to 4 of the '014 Patent.

system is provided by Cinebase. System 178 includes a component formed by method player 182, tertiary storage manager 184, archive server 186, index server 188, and client 190. **There is no clear delineation between components.** Further, there are no clearly defined lines of communication between the components. **Component interconnections are hardwired, and it is therefore impossible to substitute components that can communicate using the existing connections for the existing components.** There is no ability to split the component into discrete components such that replacement component can be substituted for one of the existing components. Further, it is impossible to split the combined component into separate components that can run on multiple hardware platforms. **The combined component offers a weak solution.**

'014 Patent, 3:15-31 (emphasis added).

98. The '014 Patent describes a multimedia management system provided by Hewlett Packard that includes an index server and a client with built-in player functionality, but does not include a method player component:

FIG. 1A

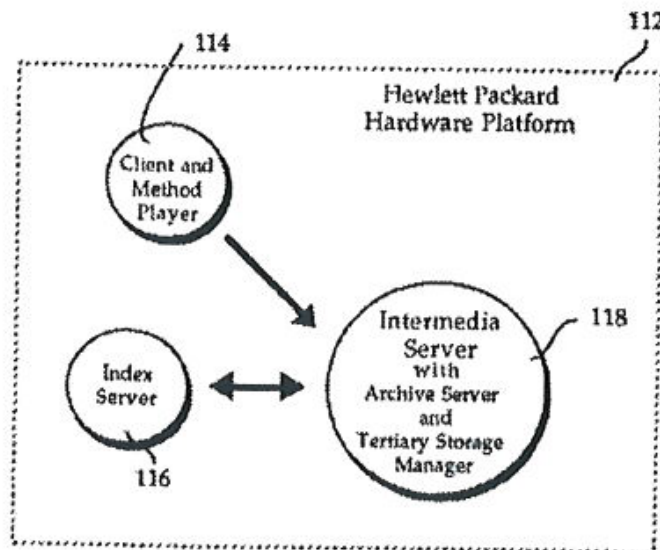

'014 Patent, Fig. 1A. Accordingly, this design is only viable with Hewlett Packard's system and is incompatible in a network that may use different clients or computers. Furthermore, the '014 Patent specifically criticizes the system's closed architecture where the hardware or software components are formed into a single proprietary system that prevents the interchangeability of system components:

The archive server and tertiary storage management subsystems are integrated in intermedia server 118. Client and method player 114 and index server 116 are interconnected with intermedia server 118 to form a single component. **The interconnections are hardwired such that it is impossible to replace one of the existing components.**

'014 Patent, 2:7-12 (emphasis added).

99. Similarly, the '014 Patent describes another existing multimedia management system by IBM. This system, like Hewlett Packard's, "offers index server 148 (e.g., Oracle's DBMS), archive server 146, and tertiary storage manager 144 in an integrated system." '014 Patent, 2:41-44. IBM's system "does not include a client or method player" and thus is again incompatible in a network that may use different clients or computers:

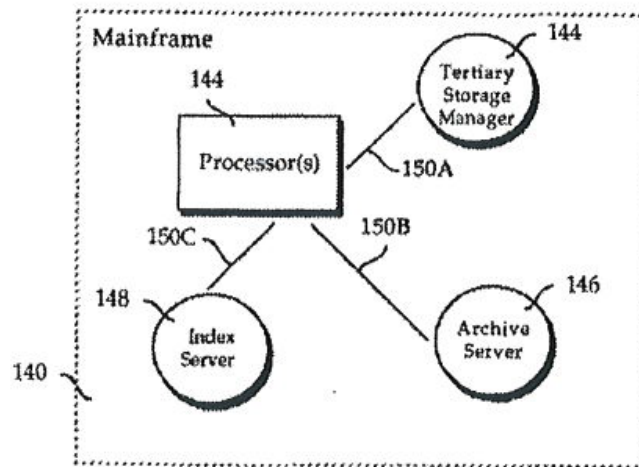

FIG. 1D

'014 Patent, 2:53-55, Fig. 1D. Like the Hewlett Packard system, the '014 Patent criticizes the IBM system for merging the component into a single proprietary system thereby creating a closed architecture:

The system is built to run in a mainframe environment using IBM hardware. Further, the system does not include a client or method player. Index server 148, tertiary storage manager 144 and archive server 146 **are combined as a single component such that it is impossible to replace one or more of them.**

'014 Patent, 2:52-57 (emphasis added).

100. Another multimedia management system described by the '014 Patent, provided by Informix “includes kernel 170 that acts as a hub.” *Id.*, 2:60-62. The '014 Patent plainly states Informix’s system “runs in a single hardware platform” and is once again incompatible in a network that may use different clients or computers:

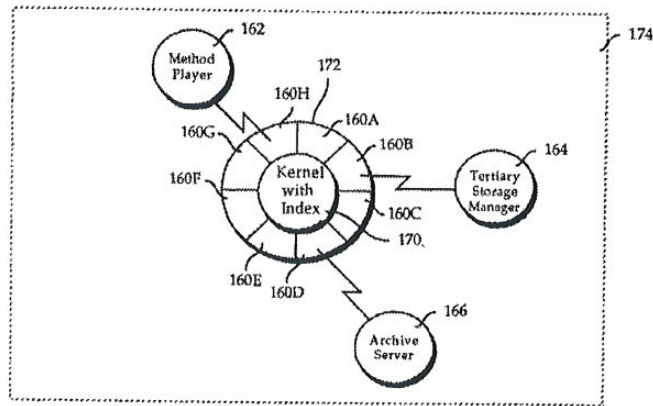

FIG. 1E

'014 Patent, 3:8-9, Fig. 1E. Again, the patent specifically criticizes the use of a proprietary interface to form a single proprietary system:

Thus, another component must communicate with the index via a proprietary interface provided by a data blade (e.g., data blades 160A-160H). Data blades 160H, 160B, and 160D provide a proprietary interface to method player 162, tertiary storage manager 164, and archive server 166, respectively. **The components provided by this system are merged to form a single component that use a proprietary interface to communicate. The component combination runs in a single hardware platform 174.** Data dictionary 172 can become large and cumbersome. In addition, a fault that occurs in one data blade that is included in data dictionary 172 causes a fault for the entire system. **This system construction is not fault tolerant and is unacceptable for a production environment.**

'014 Patent, 3:2-15 (emphasis added). Again, the Patents-in-Suit further criticize this prior art for its use of a closed architecture using proprietary protocols.

A multimedia system having a hub is illustrated in FIG. 1C. Such a system is provided by Oracle. The hub is provided by media server 130. **The system runs on a specific hardware platform** (hardware platform 138, an N-Cube hardware platform) **and is not portable to other platforms. Media server 130 acts as a**

hub that uses a proprietary interface to communicate with the other services. Components with which media server 130 can communicate are method player 122, tertiary storage manager 124, and client 120 (via lines 134, 132, and 136, respectively). . . . The component formed by media server 130, method player 122, tertiary storage manager 124, index server 128, archive server 126 and client 120 **must run on a single hardware platform**, platform 138. Further, while index server 128 is a powerful database management system, client 120, archive server 126, method player 122 and tertiary storage 124 **offer weak solutions.**

'014 Patent, 2:20-38 (emphasis added).

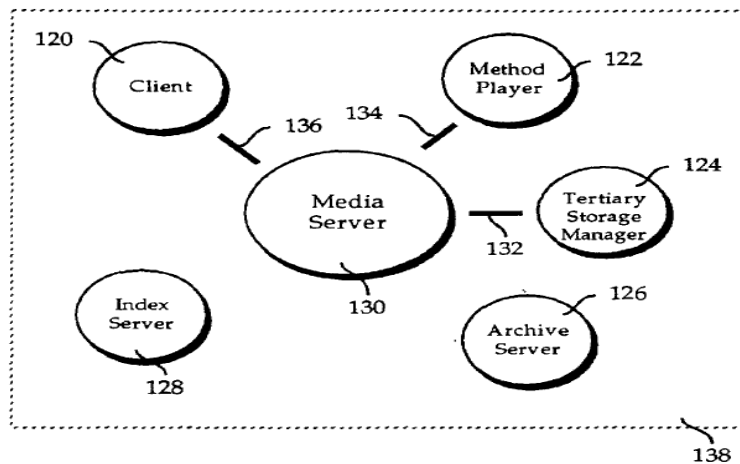

FIG. 1C

'014 Patent, Fig. 1C. The patents explain that the “closed architecture” of the merged prior art multimedia systems resulted in compatibility and replacement problems. **“This [closed] architecture is disadvantageous for at least two reasons: 1) there is no ability to replace a less capable component with another, more capable component; 2) it forces each system to run on a single hardware platform.”** '014 Patent, 1:44-47. Furthermore, “there is no vendor-independent interface available to integrate components from different vendors to construct a optimum multimedia system” “mak[ing] it impossible to replace one of the components.” '014 Patent, 3:45-47. Consequently, the prior art system cannot grow in size and capability as needs change. Nor could such closed system incorporate newer faster or more capable components as technology improved without replacing the whole system. Finally, since the systems ran on a “single platform,” these early systems could not be used to distribute the multimedia to clients beyond the propriety clients developed solely for those multimedia systems and were ill-suited

for general purpose use on computer networks such as the World Wide Web that required compatibility with disparate media players and clients of various uses on the web.

- ii. *The Distributed Architecture Claims Provide a Particularized Technological Solution to the Compatibility and Interchangeability Problems of Prior Art Systems by Setting Forth an Unconventional Modular Distributed Architecture that Used Specialized Interfaces to Allow Interchangeability Among Platforms and System Components*

101. The Distributed Architecture Claims solve the compatibility and interchangeability problems of prior art systems identified in the specification by utilizing an unconventional distributed architecture with *separable* multimedia components (software or hardware) interconnected by unconventional generalized media specific interfaces created to handle media functions that allow for interchangeability and interoperability of system components.

102. The Shoah claims implement a specific and unconventional architecture because, in addition to using a generalized API interface using a non-proprietary protocol, the claims distribute the functions of prior multimedia systems into separable components—differing from prior art system that fused (by design) the functions into a single component. Furthermore, the Shoah claims also specify additional limitations to the components including actual data structures (e.g. relationships in the catalogue data structure, additional storage management systems) and sets forth additional functional requirements of the components. Thus, the Shoah patents claim both API interfaces and multimedia components that differed from that of the prior art and the claims as a whole specify a particularized, unconventional solution.

103. The limitations of the Distributed Architecture specifically embody this unconventional architecture. For example, '014 claims 15-20 recite:

15. A multimedia system comprising:

a browser;

a text interface coupled to said browser, said text interface comprising at least one class of methods configured to specify a request for multimedia data;

an indexing server coupled to said text interface, said indexing server configured to maintain a catalogue comprising a plurality of catalogue elements associated with a plurality of keywords of said catalogue, said plurality of keywords identifying said multimedia data, said plurality of keywords being interrelated by one or more of associative, whole-part and inheritance relationships;

a first media interface coupled to said browser, said interface configured to transmit a set of identifiers (IDs) associated with said multimedia data;

an archive server coupled to said media interface, said archive server configured to locate and retrieve said multimedia data using said set of IDs;

a second media interface coupled to said browser, said interface configured to transmit said multimedia data associated with said set of IDs; [and]

a method player coupled to said second media interface.

16. The system of claim 15 wherein said indexing server comprises:

a database management system (DBMS);

said plurality of catalogue elements coupled to said DBMS;

a plurality of attributes and attribute elements coupled to said plurality of catalogue elements.

17. The system of claim 15 wherein said text interface is an application programming interface.

18. The system of claim 15 wherein said text interface contains operations for querying said plurality of catalogue elements and said plurality of attributes and attribute elements.

19. The system of claim 15 further comprising a tertiary storage manager coupled to said archive server.

20. The system of claim 19 wherein said tertiary storage manager is a cache manager.

Other claims from additional Patents-in-Suit also this architecture .

104. Unlike the prior art systems described above, this claimed architecture was unconventional and non-routine in that it distributed the functions of the multimedia system into multimedia components that can be separated from each other rather than a single merged proprietary component (e.g. a browser, an indexing server, an archive server, and a method player). This allowed functions to be handled by different software components so that when certain functionality improved (e.g., superior indexing server or better media player or a more advanced browser) that functionality could be incorporated without replacing the whole system.

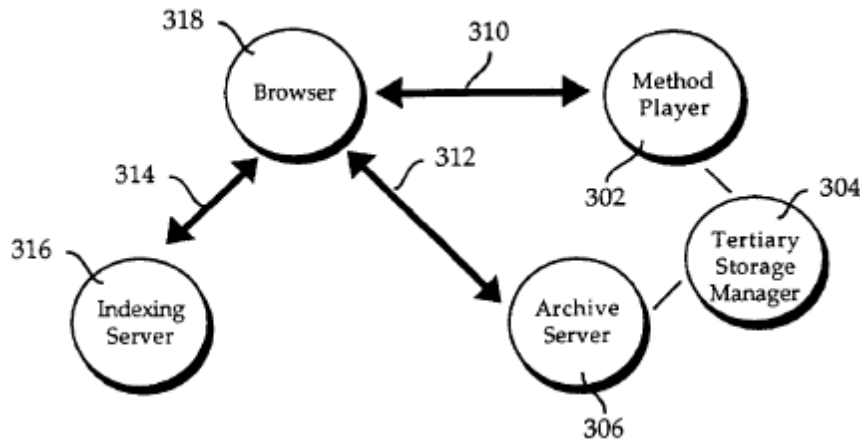

'014 Patent, Fig. 3.

105. Unlike the prior art systems that had “no clear delineation between components” and used proprietary interfaces that could not operate with components outside of the same platform, the claimed invention uses non-proprietary interfaces (depicted as 310, 312 and 315 in Fig. 3 above) to allow for modular software components from different vendors to make up a single

modular distributed system. The claimed “media interface,” “interface” and “command interface” of the Distributed Architecture claims are nonproprietary interfaces that require the use of a non-proprietary protocol:

The invention is a generalized solution for management of multimedia assets. Generalized interfaces are used between a browser component, indexing server, archive server, tertiary storage manager, and method player components. The generalized interface defines a communication protocol that can be used by any browser, indexing server, archive server, tertiary storage manager, or method player component. *Thus, system components supplied by multiple vendors can be interconnected to form a multimedia system that communicates using the generalized interfaces of the invention.*

’014 Patent, 4:66-5:8 (emphasis added). Figure 3 of the ’014 Patent depicts this novel architecture. These “media interfaces” were unconventional and non-routine because they were specially adapted for multimedia functions and used a non-proprietary protocol that could be utilized by components of different vendors for multimedia functions. In contrast, the prior art systems did not use generalized interfaces with generalized multimedia interfaces but rather were hardwired (physically or by software design) into a single component using a single platform.

106. The patents with Distributed Architecture Claims provide very extensive and specific descriptions including code detailing how to create the communication protocols that comprise examples of the unconventional general interfaces of the invention.

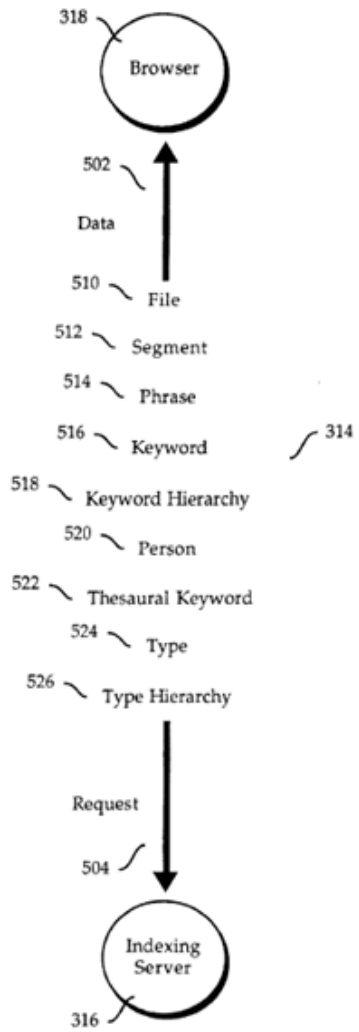

```

Testimony (or File) Routines
Get_Number_Phrases_In_Testimony(int testimony)
Returns the number of phrases in a testimony.
SQL: Select count (*)
      From Phrase
      TestimonyID = testimony
Get_Phrases_In_Testimony(int testimony, set phrases)
Returns the set of phrases in testimony.
SQL: Select PhraseID
      From Phrase
      TestimonyID = testimony
Get_PhaseStruct_In_Testimony(int testimony_id, int
phrase_id, PHRASE*P)
Returns the phrase structure identified by PhraseID, in
TestimonyID.
SQL: Select TestimonyID, PhraseID, InTimeCode,
      OutTimeCode,
      From Phrase
      Where TestimonyID = testimony
      And PhraseID = phrase
Get_Number_Segments_In_Testimony(int testimony)
Returns the number of segments in a testimony.
SQL: Select count (*)
      From PhraseCollection
      TestimonyID = testimony
Get_Segments_In_Testimony(int testimony, set segments)
Returns the set of phrases in a testimony.
SQL: Select SegmentID
      From PhraseCollection
      TestimonyID = testimony
Get_Number_Segments_In_CollectionType(int coll_type)
Returns the number of segments of a collection type.
SQL: Select count (*)
      From Segment
      Where CollectionTypeID = coll_type
Get_Segments_In_CollectionType(int coll_type, set segments)
Returns the set of a given collection type
SQL: Select SegmentID
      From Segment
      Where CollectionTypeID = coll_type
Get_Number_Keywords_In_Testimony(int testimony)
Returns the number of Keywords in a testimony.
SQL: Select count (*)
      From KeywordPhraseRecord
      TestimonyID = testimony
Get_Keywords_In_Testimony(int testimony, set*keywords)
Returns the set of keywordIDs in a testimony
SQL: Select Keyword ID
      From KeywordPhraseRecord
      Where TestimonyID = testimony
Get_Number_Thesaural_Keywords_In_Testimony(int
testimony)
Returns the number of Thesaural Keywords in a testimony
SQL: Select count (*)
      From ThesauralKeyword
      TestimonyID = testimony
Get_Thesaural_Keywords_In_Testimony(int testimony, set
*keywords)
Returns the set of Thesaural keywordIDs in a testimony
SQL: Select ThesauralKeywordID
      From ThesauralKeyword
      Where TestimonyID = testimony
Get_Number_Person_Keywords_In_Testimony(int
testimony)
Returns the number of Person Keywords in a testimony.
SQL: Select count (*)
    
```

code
impleme-
nting non-
proprietary
protocols

'014 Patent, Fig. 5 (left); '060 Patent, 24:13-67 (right).

107. As technology improves or system needs change, new software or hardware components can be efficiently swapped in to replace less capable or malfunctioning components. This flexible system not only provides unique advantages over the art and allows the system to grow as technology improves without having to replace the system wholesale, but is particularly suited to network data transmission mediums such as the Internet in which interoperability with different clients and different method players is expected, if not required. Indeed, this technology was specifically important to the Shoah Foundation as it needed to preserve and catalog more than

50,000 video testimonies for the public at large. Remarkably, this system remains still in use today.⁴¹

108. For example, the limitations of Claim 16 (which depends on claim 15) of the '014 Patent (set forth above) specifically embody this architecture by arranging a separable browser, archive server, index server, method player and API interfaces into a particular relational configuration. This claim sets forth an unconventional distributed architecture for a multimedia delivery system that distributes functions among multimedia components that are separable from each other rather than using a single merged component that was in the prior art. Furthermore, these components are connected using API interfaces (denoted by the bold arrows in Fig. 3) that contain non-proprietary protocols that allow components of different vendors to communicate with each other. This unique and inventive modular distributed architecture solves the problems of prior art identified in the specifications of the patents because it allows multimedia components of different vendors to speak to each other and be combined in the same system. Thus, one can replace multimedia components with more capable components as technology develops to create and maintain an optimum system. Furthermore, because a single hardware platform is not required, the system can interact with players of many disparate users and could be suitable for widespread distribution to users over the web and intranets. Thus, the claims go far past merely defining an abstract idea and stating apply it on a computer. By reciting this explicit and unique modular architecture, the claims are directed to the means of producing the technological improvement (i.e., an improved architecture of a multimedia system that can interchange specific

⁴¹ See, e.g., USC Shoah Foundation, Full-Length Testimonies, <https://sfi.usc.edu/full-length-testimonies>.

types of multimedia components) rather than merely claiming a result or desirable outcome on a computer.

109. Additional dependent claims recite further structural components that enhance the unconventional architecture. For example, dependent claims specifically recite a database management system (DBMS) (Claim 16), an application programming interface (API) (Claim 17), a tertiary storage manager (Claim 19), a cache manager (Claim 20), a relationship management facility, an access management system, a temporary storage cache, and a local cache. Of these, at least the indexing server, archive server, media interface, database management system, tertiary storage manager, relationship management facility, and access management system are not stock software components found in a generic computer.

110. Rather, than merely being addressed to an abstract idea or a describable outcome, the Distributed Architecture Claims are directed to a specific implementation of (software and/or hardware components) of a solution to a problem in the software arts that represents an improvement to computer functionality itself. These claims describe a *specific and therefore non-abstract implementation* of a system architecture that arranges (1) unconventional, distributed multi-media components in a (2) unconventional distributed architecture using (3) unconventional API generalized interfaces and non-proprietary protocols to improve to the way the computer system itself functions and address shortcoming in designs of prior art multimedia systems. This architecture goes far past the basic idea of a catalog or digital library but rather addresses unique technological problems unrelated to those of a brick and mortar card catalog or textual library.

111. Furthermore, the Shoah patents claim both API interfaces and multimedia components in a specific architecture that differed from that of the prior art and the claim limitations individually and as an ordered combination specify an unconventional solution that

contains multiple unconventional inventive concepts (set forth above) that render the claims patent eligible.

B. API Protocol for Distributed Multimedia Components Claims

112. The API Protocol Claims elaborate on the solution of the Distributed Architecture Claims to address the interoperability and compatibility problems described in the specification by describing with more specificity the unconventional interfaces using unconventional non-proprietary protocols for each unconventional distributed multimedia component in the unconventional architecture of Fig. 3 of the patents. The means plus function format or explicit structural limitations of the claims include as limitations specific unconventional commands, algorithms and non-proprietary functions and protocols representing non-abstract inventive concepts found in the very detailed specification of the patents. These claims refer to the same unconventional interfaces and components that were arranged in an unconventional architecture to solve problems with interoperability discussed above. The averments in Section VI(A) above in support of patent eligibility for the Distributed Architecture are reasserted here for the API protocol claims. The case for patent eligibility is even stronger here than the already patent eligible Distributed Architecture claims given the uncommon and unique level of specificity explicitly embodied in the limitations of the claims that specify non-abstract, purely structural technical solutions employing multiple inventive concepts to address the limitations found in existing multimedia systems.

C. Catalogue and Phrase Data Structure Claims

i. Technical Problems Encountered by the Shoah System

113. In the early-mid 1990s, the Shoah Foundation wanted to preserve the testimonies of the 50,000 plus then living holocaust survivors in a searchable video format. A key idea for making the content easily accessible to researchers was that the video would be subdivided and

indexed into one-minute increments so that the exact point within a video of interest could be indexed, searched for and located for a given researcher⁴²:

This meant that the system would have to index and be able to retrieve over 6,000,000 portions of multimedia content⁴³:

Each video testimony has been indexed by assigning indexing terms to the relevant one-minute segments of each testimony.

- [VHA Metrics and Details](#)

The USC Shoah Foundation's Visual History Archive, distributed by ProQuest, is a fully streaming video collection witnesses of the Holocaust and other crimes against humanity. It is the largest archive of its kind, preserving history testimony offering unique insight and knowledge rarely available in traditional content." Most testimonies contain after interviewees' firsthand experiences with genocide. The Archive includes:

- More than 54,400 video testimonies at an average of two hours each.
- Roughly 116,000 hours of film (equal to 13 years' continuous streaming content).
- Transcripts being added over time (initially over 900 German transcripts and almost 1000 English transcripts).
- Almost 65,000 index terms in English, applied at the one-minute segment.
- Over 719,000 images (photographs, documents, works of art, artifacts from war, etc.).
- 1.9 million names of family members and prominent figures.
- Roughly 49,000 location references.
- 2,500 recitations of literary works (poems, letters, diaries).
- Over 2,100 musical recitals.

114. The large amount of content of the Shoah system required more complex search methods using extensive categorization and uniformity of data content, further requiring more complex data structures to support these information retrieval ("IR") methods than previously used in conventional prior art systems and requiring search processing and delivery to be more efficient in its uses of system computing resources. At that time, no conventional multimedia system possessed the technological features to accommodate such a large library, nor were such systems capable of providing the advanced indexing and search capabilities necessary to search such a library effectively. This period was long before Netflix or YouTube, and IR techniques for large

⁴² <https://sfi.usc.edu/vha/indexing>

⁴³ <http://researchguides.library.syr.edu/vha>

scale *textual* document databases were largely experimented or just being developed. These conventional text based IR techniques for term based searching and document representation were simply inadequate for the needs of a large scale *video* library such as the Shoah system.

115. Furthermore, as discussed more extensively above, the Shoah system needed to implement a distributed architecture that used nonproprietary interfaces to integrate multimedia components from different vendors and across platforms. The Shoah system's complex search systems, large amount of data, and unique distributed architecture employed multiple applications to effectively retrieve and deliver its content—placing more demand on system computing resources. More efficient data structures supporting multiple applications were necessary to address bandwidth and search processing issues associated with a large scale video collection.

ii. Conventional Text Based IR Methods and Data Structures Were Inadequate to Support Searching of a Large Scale Video Collection

116. Information retrieval in this time period for multimedia systems presented unique problems for the Shoah system that were not present in conventional text-based document retrieval. Consequently, conventional document representation in the data structures used by the then existing text base searching were inadequate for robust searching of a large video collection. For example, U.S. Patent No. 7,240,003 titled “Database annotation and retrieval” to Charlesworth et al. at 1:18-23 notes:

Existing database search tools allow the user to search the database using typed keywords. Whilst this is quick and efficient, this type of searching is not suitable for various kinds of databases, such as video or audio databases.

The lack of text in videos prevented implementation of conventional document IR techniques or early web-based methods of search. Since there is no native text in a video, one simply cannot match search terms to words found in the content of a video in the same way that one does for a textual document. In order to perform robust term-based searching on a video, an additional “document representation” layer to a traditional word index was needed. For example, a text-

based document can be effectively searched by creating a simple index of the words contained in a document. A video has no native text and may not even have spoken words and that the conventional indexes used by these systems would inadequately represent the document for effective term-based searching. Moreover, the lack of native text in the video itself also precluded automated extraction or creation of textual content to create traditional word indices for a large-scale system used for conventional searching.⁴⁴ Without automated extraction of text, the traditional approaches found in early large-scale web search systems employing conventional search methods and data structures could not be practically employed to search a large-scale database of millions of video portions. One simply could not use a crawler or extractor to create usable indices for term-based searching for videos in the same manner as a text-based systems such as those used in web search.

iii. The Catalogue Claims Describe Structurally a Specific Technical Implementation of a Improved Data Structure that improved the Functioning of the Computer

117. The original Shoah system employed significant improvements over prior art systems in creating unconventional data structure and databases directed to addressing the unique technological problems of searching for multimedia data discussed above and to efficiently enable multiple applications in a complex multimedia system by minimizing the need for multiple disparate data structures and databases supporting different applications.

⁴⁴ Howard Wactlar et al., *Intelligent Access to Digital Video: Informedia Project*, IEEE Computer, May 1996, at 46, 48 (available at http://ri.cmu.edu/pub_files/pub2/wactlar_howard_1996_3/wactlar_howard_1996_3.pdf) (“Video information is temporal, spatial, often unstructured, and massive... As a result, a complete solution—**automatic extraction of semantic information or a general vision recognition system—is not yet feasible.**”) (emphasis added).

118. These improvements are found in the Catalogue Claims. To solve this problem with searching of large-scale video databases, Samuel Gustman created an additional document representation layer housed in a data structure called the “Catalogue.” Rather than term indices just being directed to the textual content of the document or video itself, the Catalogue provide an unconventional document representation layer that is further indexed and searched by other indices:

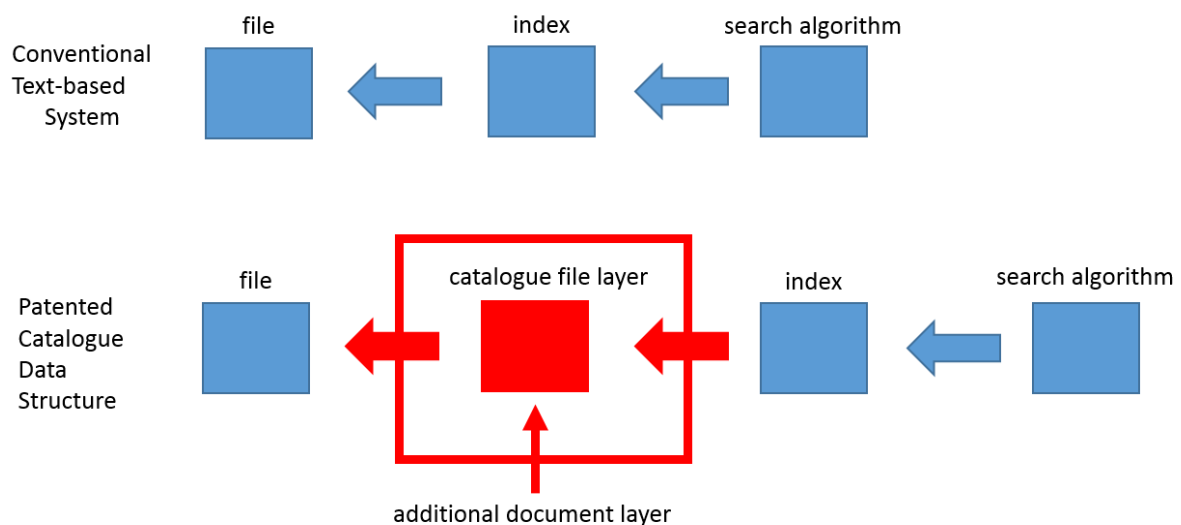

Unlike the simple word index document representations used by conventional IR, the inventive catalogue element contains multiple storage dimensions (attributes and attribute elements) representing non-textual content of the video as well as specialized external and self-referencing relationships for improving search, bandwidth and processing efficiency. A feature of the claimed “Catalogue” is that it centralizes much of the data into a single data structure that can be housed in a separable indexing server multimedia component for use in the distributed architecture of the invention.⁴⁵

⁴⁵ For example, '014 claim 15 requires a catalogue containing key words that identify multimedia data coupled to the text interface that specifies a request for multimedia data. It further requires that the IDs of the supplied multimedia data be used by the remaining components of the system:

119. This data structure was designed to support several search methods as well as serve as a single repository of data that supports multiple applications found within the distributed architecture of the invention. By designing a flexible, central repository for all applications rather than unique databases designed for each application, the system has the benefits of increasing the efficiency and reducing the memory consumption of the system, as well as expanding the search capabilities of the system.

120. The claim term “catalogue” is a coined term described in the specification. The specification describes the structure of the catalogue embodiment as having three storage dimensions comprising a catalogue element; attribute and attribute elements:

A catalogue is a collection of one or more catalogue elements. An element of a catalogue has one or more attributes. An attribute provides information that can be used to search for, answer questions about, and navigate through a catalogue. An attribute of a catalogue element can be an element that has attributes. A catalogue element attribute that is an element is referred to as an attribute element. Attribute elements and attributes are used to build an index that can be used to facilitate catalogue access. Within a catalogue, smaller catalogues can be created by, for example, querying and user designation.

'014 Patent, 8:64-9:8. Fig. 4A depicts a catalogue with catalogue elements, attributes and attribute elements as well as pointers between catalogue elements:

15. A multimedia system comprising:
a browser;
a text interface coupled to said browser, said text interface comprising at least one class of methods configured to specify a **request for multimedia data**;
an indexing server coupled to said text interface, said indexing server configured to maintain a catalogue comprising a plurality of catalogue elements associated with a plurality of keywords of said catalogue, said plurality of **keywords identifying said multimedia data**, said plurality of keywords being interrelated by one or more of associative, whole-part and inheritance relationships;
a first media interface coupled to said browser, said interface configured to transmit a set of identifiers (IDs) **associated with said multimedia data**;
an archive server coupled to said media interface, said archive server configured to locate and retrieve **said multimedia data using said set of IDs**;
a second media interface coupled to said browser, said interface configured to **transmit said multimedia data associated with said set of IDs**;
a method player coupled to said second media interface.

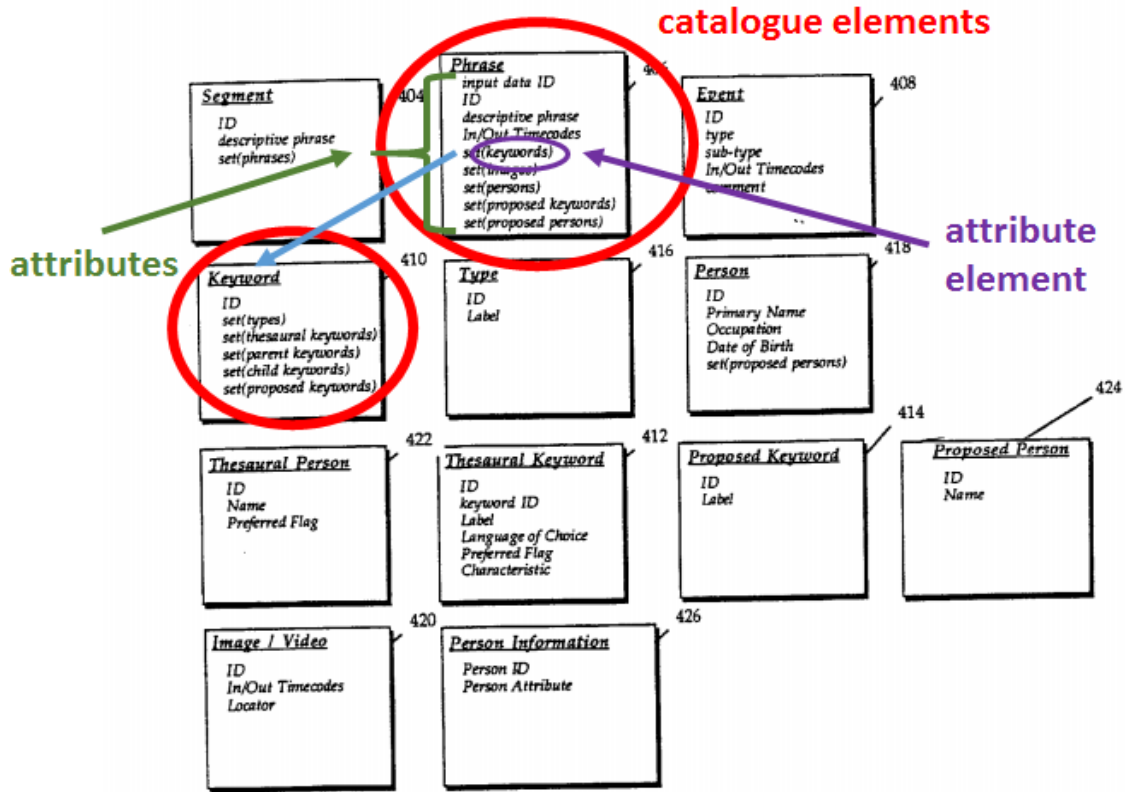

FIG. 4A

121. A “catalogue element” refers to a data structure about a specific data type (types, keywords, persons, segments etc.) or multimedia (whole or portion of a video) that is accessible by an index. ’014 Patent, 8:10-35; See Fig. 4A. An attribute is contained within the catalogue element and contains information about the given catalogue element. *Id.* An attribute element represents a further elaboration of data relevant to a given attribute. Typical attributes include segment references; phrase references; person references; type references; keyword references and other associations. The catalogue elements are interrelated with each other with pointers or references.

122. Important to this unconventional structure and a difference with conventional data representation of video and other files is the fact that each catalogue element represents a modular datum component that can be combined through relationships (e.g. pointers) to represent a particular video. *See* Fig. 4A and B of the '014 patent. A particular video is represented by the interrelation of various catalogue elements. For example, a video portion can be catalogued by a phrase identifying a particular portion of video. This phrase may be associated with a combination of type, person, keyword, and segment catalogue elements to create an efficient document representation of the video. The attributes of the representation may be efficiently searched by the novel search algorithms of the system. These storage structures contain among other things structured data that could be used to locate multimedia in a file which otherwise does not contain any text—a problem uniquely associated with retrieval of multimedia files as opposed to documents. Other claims from additional Patents-in-Suit also reflect the structure of the claimed catalogue including the three storage dimensions and interconnection. It should be noted that certain claims of the Patents-in-Suit vary significantly in scope (and specificity) and each claim contains different relevant features for a 101 analysis and are not representative of each other. Additional claims bear limitations that vary in specificity and scope related to a given improvement discussed here but the dependents specify more relevant specific structure for purposes of a 101 analysis than the independents.

123. The Catalogue was also coupled to a relationship management and cataloguing facility that allowed modification of the data and addition to the relationships stored in the system so as to address the flexibility needs of multiple applications and general interfaces. '495 Patent, 14:52-64.

124. Another key unconventional feature of a catalogue element in the disclosed embodiment is that it contains unconventional self-referential relationships (e.g. pointers or references) to other catalogue elements so that more efficient retrieval and the reduction of data structures could be had. Generally, the system employed three kinds of relationships: associative; whole-part and inheritance relationships. '495 Patent, 13:48-62. These relationships are integrated into the specific search query algorithms of the system and the interface protocols between multimedia components so that specific catalogue elements and their attributes and attributes could be efficiently retrieved.⁴⁶

125. For example, one kind of relationship will associate two different keywords. By use of the catalogue attributes a search will not only retrieve those catalogue elements of the specified keyword but also catalogue elements containing keywords of the associated keyword. '014 Patent, 15:9-23. Whole-part and/or inheritance relationships allowed for an expanded retrieval set by not only retrieving catalogue elements containing the relevant keyword but also retrieving portions of multimedia data that are part of a given catalogue element that does not contain the keyword or other catalogue elements that are of the same type or made by the same person that lack the keyword. '495 Patent, 40-50.

⁴⁶ For example, '014 claims 16-18 recite:

16. The system of claim 15 wherein said indexing server comprises:

a database management system (DBMS);

said plurality of catalogue elements coupled to said DBMS;

a plurality of attributes and attribute elements coupled to said plurality of catalogue elements.

17. The system of claim 15 wherein said text interface is an application programming interface.

18. The system of claim 15 wherein said text interface contains operations for querying said plurality of catalogue elements and said plurality of attributes and attribute elements.

126. These relationships comprise self-referential relationships to the catalogue in that they refer to other catalogue elements within the same catalogue data structure. '495 Patent, 11:15-17 (“In the preferred embodiment, catalogue and attribute elements are interrelated. Relationships are formed between two or more catalogue elements within the catalogue data structure (e.g., keyword to type, marked in green, below):

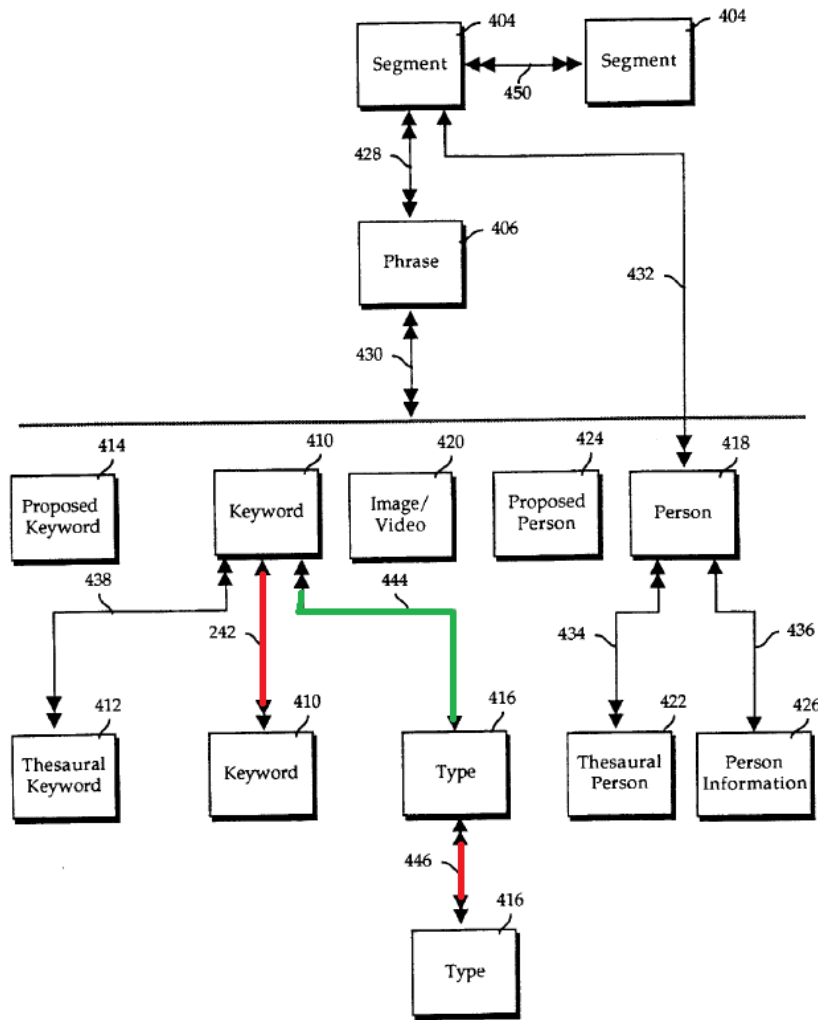

FIG. 4B

127. The Catalogue embodiment also has self-relationships where a given catalogue element can refer internally to other elements *within the same catalogue element*. For example, a

keyword can refer to another entry within the same keyword catalogue element or a type can refer to another type instance (e.g., keywords to other keywords; types to other types, marked in red above). Thus, the unconventional claimed catalogue using self-referencing relationships to internal elements of the catalogue allows many kinds of searches involving attributes that can be efficiently processed with less data tables and replications of queries on the catalogue—further reducing the bandwidth and processing resource consumption of the distributed network connecting multiple applications.

128. The self-referencing relationships of the claimed catalogue are explicitly reflected in limitations of the claims. For example, claim 2 of '495 patent provides:

1. In a computer system, a method of cataloguing multimedia data comprising the steps of:

creating a catalogue comprising a plurality of elements and relationships between said plurality of elements, said plurality of elements identifying data associated with said multimedia data, said data including keywords interrelated via one or more associative, whole-part and inheritance relationships, and other multimedia data associated with said multimedia data **[self referencing key word to key word relationships]**;

specifying a description for a portion of said multimedia data;

creating a catalogue element in said catalogue, said catalogue element containing a pointer to said portion of said multimedia data; and

creating for said catalogue element a pointer to at least one of said keywords, said at least one of said keywords containing a plurality of pointers to a set of elements in said catalogue interrelated to said at least one of said keywords via said one or more associative, whole-part and inheritance relationships, and creating for said catalogue

element a plurality of pointers to elements in said catalogue that identify other multimedia data associated with said portion of multimedia data.

2. The method of claim 1 wherein said step of creating a pointer to at least one of said keywords further comprises the steps of: identifying references to said at least one of said keywords in said description; and creating said pointer to at least one of said keywords for said catalogue element **[further structural description of self referencing relationships]**.

129. Another example is '495 patent, claim 22 (which depends on claims 13, 19, and 20) that claims the (1) basic catalogue data structure (2) usage of the attribute and attribute elements of the catalogue (3) self-referencing relationships between catalogue elements; (4) keyword associations with catalogue elements and other keywords (self-reference); (5) phrase element data structure directed to portion of multimedia; (6) pointer to specific storage location; (7) modification of the data structure and other features discussed below:

13. An article of manufacture comprising:

a computer usable medium having computer readable program code embodied therein for cataloguing multimedia data using a general indexing structure, the computer readable program code in said article of manufacture comprising;

computer readable program code configured to cause a computer to create a catalogue

[coined term referring to the catalogue data representation described in specification] comprising a plurality of elements and relationships between said plurality of elements **[self referencing internal relationships and catalogue elements]**, said plurality of elements identifying data associated with said multimedia data, said data including keywords interrelated via one or more associative, whole-part and inheritance relationships, and other multimedia data associated with said multimedia data **[self-references between keywords within the keyword catalogue element]**;

computer readable program code configured to cause a computer to specify a

description for a portion of said multimedia data **[description for phrase data structure for a portion of multimedia]**;

computer readable program code configured to cause a computer to create a catalogue

element in said catalogue, said catalogue element containing a pointer to said portion of said multimedia data **[limitations directed to phrase data structure catalogue element including pointer]**; and

computer readable program code configured to cause a computer to create for said

catalogue element a pointer to at least one of said keywords, said at least one of said keywords containing a plurality of pointers to a set of elements in said catalogue interrelated to said at least one of said keywords via said one or more associative, whole-part and inheritance relationships, and creating for said catalogue element a plurality of pointers to elements in said catalogue that identify other multimedia data associated with said portion of multimedia data **[self referencing internal relationships of the catalogue (e.g., segment structure)]**.

14. The method of claim 1 wherein said step of retrieving further comprises the steps of: searching cache for said portion of said multimedia data;

retrieving said portion of multimedia data into said cache from permanent storage, if said portion of multimedia data is resident on permanent storage and is not found in said cache **[using the catalog for efficient catching of portions]**.

19. The article of manufacture of claim 13 further comprising computer readable program code configured to cause a computer to delete said catalogue element.

20. The article of manufacture of claim 19 wherein said program code configured to cause a computer to delete further comprises:

computer readable program code configured to cause a computer to identify said at least one of said keywords,

computer readable program code configured to cause a computer to reassign said at least one of Said keywords when Said at least one of Said keywords can be reassigned;
computer readable program code configured to cause a computer to delete said at least one of Said keywords when Said at least one of Said keywords cannot be reassigned;
computer readable program code configured to cause a computer to delete said catalogue element.

22. The article of manufacture of claim 20 wherein said program code configured to cause a computer to delete further comprises:

computer readable program code configured to cause a computer to locate a plurality of attributes and attribute elements **[searching of attribute and attribute element storage dimensions]**, said second plurality of attributes and attribute elements are related to said at least one of said keywords, computer readable program code configured to cause a computer to reassign said plurality of attributes and attribute elements when said plurality of attributes and attribute elements can be reassigned;
computer readable program code configured to cause a computer to delete said plurality of attributes **[above and below references allow modification of data structure]** and attribute elements when said plurality of attributes and attribute elements cannot be reassigned;
computer readable program code configured to cause a computer to delete said plurality of attributes and attribute elements.

130. Other claims from additional Patents-in-Suit also reflect the structure of a catalogue with self-referencing pointers.

131. Another type of self-referencing relationship of the catalogue is the use of an unconventional segment container catalogue element. Segments are container catalogue elements that contains list of references to other catalog elements and therefore are self-referential. *See*

infra at Section VI(D)(iii) for an extended discussion of segment and container elements. Other claims also reflect self-referential relationships involving segment containers.

132. Still further, the catalogue data structure with its storable attributes and attribute elements (in combination with the claimed relationships) is designed to enable the specific search algorithms disclosed in the patents. Unlike conventional systems, this unconventional data structure included specific multimedia data that reflect non-textual content of the video such as associated (1) “key words” associated with the video (2) type classifications, (3) identification of segment containers grouping related content; (4) segments attributes associating catalogue elements with prior searches; (5) person associations; (6) testimony attributes; (7) general description of the content of the video; (8) key word to key word associations; (9) cache identification; (10) associative; inheritance and whole part relationships; and (11) phrase elements. Thus, the Catalogue allowed for much more advanced searching based upon several categories of information that was not explicitly contained with the video text to address the unique problems of video searching. These algorithms address limitations in conventional systems by improving search capability using improved document representation structures over prior art systems and allowing expanded search results based upon associative; whole part; and inheritance relationships—structures not in conventional use or understanding.

133. The claimed catalogue with its modular catalogue elements, attributes, and attribute elements document representation are also necessary to support the non-proprietary interfaces of the invention that query the catalogue to search, retrieve and display multimedia. For example, the Browser-Indexing Server interface routines disclosed in the ’537, ’831 Patent and ’014 patent use the attributes and attribute elements stored in the catalogue to search for data in the indexing server and then retrieve the data using the archive server from storage, for example:

Get_PhraseStruct_In_Testimony(int testimony_id, int phrase_id, PHRASE*P)

Returns the phrase structure identified by PhraseID, in TestimonyID.

SQL: Select TestimonyID, PhraseID, InTimeCode, OutTimeCode,
From Phrase
Where TestimonyID = testimony
And PhraseID = phrase

'014 Patent, 27:3-10; 21:29-43. Thus, the specific routine references the following attributes and attribute elements including testimonyID, phraseID and phrase data structures.

134. These routines enabled by the Catalogue are part of the non-proprietary interfaces and protocols disclosed in the specification that are necessary to implement the open and distributed architecture containing multiple applications discussed above with the Distributed Architecture claims. The means plus function claims directed to interfaces specifically claim as limitations the use of the attribute, attribute elements, segment and phrases of the claimed catalogue. The design of the Catalogue improves the limitations in the prior art in that they can be used to implement the unconventional nonproprietary protocols disclosed in the specification and incorporated in the claims. The catalogue enabling these interfaces addresses the interoperability problems in the art between applications of multiple vendors that are discussed at length in the '014 Patent, '537 patent and '831 patents as well as reduces the number of data structures used by the multiple applications of the invention.

135. The unconventional specific structures of the Catalogue with the features described above represent technical improvements to conventional data structures used in multimedia systems and electronic search systems. Consolidation of the features described above in a given claimed catalogue data structure reduces the number of necessary data structures that have to be stored and referenced. This improves the art by reducing memory requirements, system resource and bandwidth consumption, and the time necessary to process the complex search algorithms

described in the specification. Also, the claimed relationships contained in the system enable multi-faceted complex searches that reduce the number of times the interface must query catalogue -again freeing up bandwidth, reducing processing time and the number of times the indexing server must be accessed. Each of the above described and claimed features when considered within the ordered combination of the claims define an unconventional data structure that constitutes an inventive concept that renders patent eligibility.

- iv. The Specification Confirms that the Claimed Catalogue is an Unconventional, Non-Routine and Not Well Understood Technical Improvement to the Data Structures of the Prior Art Multimedia Systems*

136. The Shoah patents' conception in the early 1990s occurred during the early development of multimedia delivery systems and the data structure design of those systems. Only a few systems with limited capabilities were in production by the time of filing of the application. The basic catalogue document representation layer as well as other more specific claimed features of the catalogue discussed above⁴⁷ were not conventional or well understood activities in routine practice within existing multimedia systems and represent inventive concepts that support patent eligibility. Existing systems lacked the basic catalogue documentation layer searched by word indices as well as the unique other claimed features concerning the claimed catalogue.

137. The specifications of the Patents-in-Suit extensively discuss the problems and limitations that the claimed invention intended to address as well as the state of art for existing multimedia systems. For example, columns 1 to 3 of the '495 Patent discusses 8 references (U.S.

⁴⁷ For example, the catalogue includes specific multimedia data that reflect non-textual content of the video such as associated (1) "key words" associated with the video (2) type classifications, (3) identification of segment containers grouping related content; (4) segments attributes associating catalogue elements with prior searches; (5) person associations; (6) testimony attributes; (7) general description of the content of the video; (8) key word to key word associations; (9) cache identification and storage locations; (10) associative; inheritance and whole part relationships; and (11) phrase elements.

Pat. No. 5,414,644 to Seaman; U.S. Pat. No. 5,404,506 to Fujisawa; U.S. Pat. No. 5,241,671 to Reed; U.S. Pat. No. 5,123,088 to Kasahara; U.S. Pat. No. 5,210, 868 to Shimada; U.S. Pat. No. 5,278,946 to Shimada; and U.S. Pat. No. 5,493,677 to Balogh) concerning prior art search methods, data structures and applications. It first describes the problem with existing systems in their inability to search based upon the content of the video (a problem that the Catalogue document representation was designed to address):

A problem with prior art multimedia systems is an inability to search and retrieve multimedia data...Other than the extent to which the file name identifies content, the file System *does not provide the ability to retrieve multimedia information based on the content of the data.*

'495 patent, 1:24-30. Then '495 Patent describes the lack of a Catalogue in existing systems:

The search capabilities in the patents identified above do not provide an ability to catalogue multimedia data ...*There is no ability to create a general catalogue and index for searching a catalogue that can be used for the storage and retrieval of multimedia data by multiple applications.*

Id. at 2:38-47.

138. Numerous publications cited by the prosecution history or known in the art confirm these technical limitations of the art.

“In order to make the best use of a computer's ability to manipulate digital audio and audio-video recordings, it is desirable to have some way to perform content searches. Currently, the ability **to perform content searching is significantly limited or non- existent.**”

U.S. Patent No. 5,794,249 titled “Audio/video retrieval system” to Orsolini et al. at 1:21-25.

Existing database technology is not designed to manage digital video as “first class” media. **By this we mean that very little support is available for indexing and querying video based on its content...**The systems that retrieve images or video data based on feature components make extensive use of on-the-fly image processing techniques. **These techniques are not suitable for very large collections of video**, as they require a great deal of computational power and processing time.

Ahanger, G., Benson, D., and Little, T., *Video Query Formation*, Proc. Storage and Retrieval for Images and Video Databases III, IS&T/SPIE Symposium on Electronic Imaging Science & Technology, vol. 2420, pp. 280-291, available at

<http://citeseerx.ist.psu.edu/viewdoc/download?doi=10.1.1.477.5252&rep=rep1&t>

ype=pdf.

“[T]ext based search tools are the predominate search tools available on the internet today. Even if text based search algorithms are enhanced to examine files for file type and, therefore, be able to detect whether a file is a audio, video or other multimedia file, **little if any information is available about the content of the file beyond its file type.**”

U.S. Patent No. 5,903,892 titled “Indexing of media content on a network” to Hoffert et al. at 2:8-14.

“While there are efficient search engines for text documents today, there **are no satisfactory systems for retrieving visual information.**”

Chang et al., *VideoQ: an automated content based video search system using visual cues*, Proc. of the Fifth ACM International Conference on Multimedia, pp. 313-324, available at <https://www2.cs.ucy.ac.cy/~nicolast/courses/cs422/ReadingProjects/videoq.pdf>

139. '014 Patent, col. 1-4 further discusses five existing systems (Hewlett Packard, Oracle, IBM, Informix, and Cinebase) in detail (illustrated in Fig. 1B-1F) and notes that these systems lacked the claimed Catalogue and features:

None of these systems illustrated in FIGS. 1B-1F provide a general cataloguing capability that can catalogue any type of multimedia data.

'014 Patent, 3:35-36. The '014 patent further discusses U.S. Pat. No. 5,192,999 to Graczyk; U.S. Pat. No. 5,283,638 to Engberg; U.S. Pat. No. 5,283,819 to Glick; U.S. Pat. No. 5,297,249 to Bernstein; U.S. Pat. No. 5,307,456 to Mackay; U.S. Pat. No. 5,402,499 to Robison; U.S. Pat. No. 5,428, 730 to Baker et al.; U.S. Pat. No. 5,434,592 to Dinwiddie; and U.S. Pat. No. 5,436,898 to Bowen. It criticizes each of these prior art for lacking the claimed Catalogue as well as other features:

A number of prior art patents that describe software and/or hardware systems are provided below. These systems do not provide a general cataloguing capability[.]

'014 Patent, 3:48-50.

140. The lack of conventionality of the claimed catalogue is further confirmed by contemporaneous external sources:

If [a reader] has specific questions (queries) in mind, such as finding a term or a key word,

he can go to the Index page and find the corresponding book sections containing that question. Both aspects are equally important in helping users access the book's content. For today's **video** data, unfortunately, **we lack both the ToC and video Indexes to facilitate browsing and retrieval.**

Syed, M., *Design and Management of Multimedia Information Systems: Opportunities and Challenges*, 22-49 (2001).

In known systems, information is simply “pushed” to the user with no provisions for interactivity. **Known systems do not address audio- visualization of content information at all..** There is no way for the user to learn additional information about the subject of the image as displayed.

U.S. Patent No. 6,070,167 titled “Hierarchical method and system for object-based audiovisual descriptive tagging of images for information retrieval” to Qian et al. at 1:32-39.

In theory, semantic primitives of video, such as interesting objects, actions and events, should be used. However, such **general semantic analysis is not feasible**, especially when information from soundtracks and/or close caption is not available. **In practice, we have to rely on low-level image features and other readily available information.**

Zhang, H., “Content-based video analysis, retrieval, and browsing,” *Multimedia Information Retrieval and Management: Technological Fundamentals*, 44 (2003).

Because media assets are so crucial to these [media and advertising/business] companies, they have an **extreme need for an intelligent and efficient way to catalog, browse, search and manage their media assets....**

U.S. Patent No. 6,567,980 titled “Video cataloger system with hyperlinked output” to Jain et al. at 1:45-50.

141. The '495 patent also notes that some prior art information retrieval systems inefficiently used multiple databases and data structures rather a centralized Catalogue with multiple dimensions to support searching:

A system for database retrieval wherein entries in different databases are retrieved by a process of matching key words of the databases is described in U.S. Pat. No. 5,210, 868, Shimada et al., issued on May 11, 1993. Examples of two such databases are a mapping database and a customer attribute database. A dictionary is used to Separate a keyword from a first database into common and proper noun subparts. Common and proper noun Synonyms are inferred according to a set of

rules. The Synonyms are combined using a combination rule and then compared with keywords in a Second database to generate a final matching result.

'495 Patent, 1:55-65. The '495 Patent describes search capabilities of hypertext systems and notes the problem with these systems is that “[a] hypertext nodal network is needed to use the indexing capability in this case”—a feature lacking in non-textual multimedia. *Id.* at 2:48-57.

142. The prosecution history of the '014 patent confirms that the claimed use of certain types of internal referencing relationships in the claimed Catalogue was found to be absent in the art which is further evidence of the lack of conventionality or routine use of these claimed features.

Applicant argued to the PTO:

In contrast, the claimed invention is directed to a method of accessing multimedia data wherein a catalogue is defined and comprises a plurality of catalogue elements that are associated with multimedia data. The catalogue elements are associated with a plurality of keywords in the catalogue that are interrelated by one or more of associative, whole-part and inheritance relationships. Thus, the structure of the catalogue includes relationships between catalogue elements and keywords that are interrelated via one or more whole-part, associative and inheritance relationships.

Response dated March 5, 1998 in Application No. 08/678,727 at 22 (attached hereto as “**Exhibit 6**”).

143. The Examiner’s reasons for allowance agreed with this assertion, stating the “method and system for accessing multimedia data having a plurality of catalogue elements associated with catalogue keywords being interrelated by one or more associative, whole-part and inheritance relationships, searching, browser and indexing the server configured to maintain catalogue elements, and having the interface configured to transmit set of identifiers associated with multimedia data, was not suggested over the prior art.” Notice of Allowability dated March 26, 1998 in Application No. 08/678,727 at 2-3 (attached hereto as “**Exhibit 7**”).

144. These descriptions of the limitations of prior art systems and others found in the patents represent important contemporaneous evidence of eligibility under 101. They establish that the technical solution embodied in the Catalogue claims are addressed to remedy technical

problems in the art; and therefore represent an improvement to existing technology. They also represent evidence of the lack of conventionality of the claimed solution and therefore further support the presence of inventive concepts in the claims.

- v. *The Phrase Data Structure Claims Structurally Describe a Specific Technical Implementation of an Improved Data Structure that Enhances the Function of the Computer*

145. The Phrase data structure Claims (by example only, '014 claims 21-25) describe further improvements to the catalogue that represent independent grounds for patent eligibility. The "Phrase" data structure is a coined term directed to a data structure for searching for specific portions of a video. The original Shoah system employed a significant advance in search capability over the limitations of conventional prior art multimedia systems and this advance was embodied in the Phrase data structure claims (e.g., '014 claims 21-25). Prior art multimedia search systems would index and retrieve whole videos in response to search criteria; however, such systems were unable to search and retrieve specific content or portion *within* a video. Thus, a viewer would have to review the entire contents of a video to manually locate and view portions of that video of interest which is a time-consuming process.

146. The Shoah system improved the search capabilities over prior art systems by using a Catalogue stored in a separate indexing sever that indexed the contents of video in one-minute segments and then configured the multimedia data so that the search could retrieve the specific portion of interest in a video file and begin playing the portion:



VISUAL HISTORY ARCHIVE®

CENTER FOR ADVANCED GENOCIDE RESEARCH

EDUCATION PROGRAMS

GLOBAL W

[Home](#) » [About the Visual History Archive](#) » [About the Visual History Archive](#)

CATALOGUING AND INDEXING

Compiling 55,000-plus video testimonies of survivors and witnesses of the Holocaust and other genocides was a feat of archival collection that remains unmatched.

But this accomplishment gave rise to a new challenge: How can this immense resource be used if the information it contains isn't searchable?

Anticipating this challenge in the early years, USC Shoah Foundation assembled a team of historians, technology professionals, software engineers, and information-management experts to develop the Institute's indexing system. The work was painstaking, and by 2001 only about 4,000 testimonies had been fully indexed. By 2005, the number had swelled to 46,000. Today, the entire trove of testimony in the Visual History Archive – which would take 12 years of 24-hour viewing to watch from beginning to end – has [a built-in search engine that enables users to pinpoint moments of interest to the minute.](#)

Developing such a robust search mechanism required innovation, and USC Shoah Foundation currently holds 11 patents on digital collection management technologies.

USC Shoah Foundation, Cataloguing and Indexing, available at <https://sfi.usc.edu/vha/indexing>.

For example, if one wants to search the system for the exact part of a video where the speaker is telling his story about hiding in an attic in Poland to avoid being taken to Auschwitz, he could put in the terms “Auschwitz,” “attic” and “Poland,” and the system would not only retrieve the video that was related to those terms, it would retrieve the specific portion of the video where such discussions took place, and cue it for playback. These unconventional and novel features are still in use today and can be viewed at <https://sfi.usc.edu/full-length-testimonies>.

147. The patents in suit and, more specifically, the Phrase Data Structure Claims, are directed to this improvement to the shortcomings of the prior art systems. However, rather than broadly claiming the basic idea of this improved search capability, the specification and the claims are directed to the specialized and unconventional data structures and multimedia components used to technically implement this feature. Rather than claiming the end result, they “describe how”

or “the specific means” in terms of data structures and search methods to technically improve the system to achieve the enhanced search capability.

148. The catalogue with the Phrase Data Structure Claim’s limitations, individually and as an ordered combination, represent an unconventional, non-routine, and not well understood technical solution embodying one or more inventive concepts that impart patent eligibility. This inventive catalogue structure enables the ability to search for portions of a video associated with one or more attribute(s), such as a keyword, a person etc.:

The multimedia data catalogue used in the invention preferably consists of one catalogue element that is referred to as a phrase. **A phrase is associated with a portion of multimedia data. ...The index can be used to navigate through the catalogue (e.g., search for phrases).** '495 patent, 8:10-24.

The archive server maintains an identification of the location of the multimedia data. Thus, when a set of catalogue elements is received from the browser, the archive **server can identify** the location of the portions of multimedia data having the desired content (i.e., the portions of multimedia data associated with the catalogue elements 10 contained in the set).

'499 patent, 5:5-10. Users may advantageously retrieve the portion of relevant multimedia data without viewing the entire multimedia data file. Instead of associating catalogue elements with the entire multimedia data file, the multimedia data is divided into portions, each portion associated with its own indexing in the catalogue and attribute elements:

The elements described can also be instantiated to catalogue multimedia data ...Catalogue B has a **plurality of instances of phrase 206 each associated with a portion of multimedia 60 data 1802B**. Each instance of phrase 206 has one or more attributes and/or attribute elements. **Attributes such as an in timecode and**

an out timecode identify a portion of the video from an event that is associated with an instance of phrase 206.

'495 patent, 25-52-65.

Multimedia data 1802C can contain other data for which a catalogue can be used to organize the data for storage and retrieval. Instances of keyword 210, type 216, and person 218 can be instantiated and associated with each catalogue instance (e.g., an instance of phrase 206). **Instances of keyword 210 and its associated instances of thesaural keyword 212 can be used to identify the content of a portion of multimedia data associated with the instance of keyword and its associated instance of phrase 206.**

'495 patent, 26:22-31

149. A phrase in the described embodiment and claimed is an unconventional data structure that is an element of a catalogue stored in a separate indexing server. Many of the claims specifically claim the feature by requiring a “portion of multimedia” to be indexed and represented in the catalogue as a catalogue element that can be retrieved for playback.

150. The unconventional “phrase” element differs from conventional prior art data structures in many important ways necessary for achieving the enhanced multimedia search capabilities. The phrase data structure is directed to a portion of a video. The phrase record contains a description of the contents of a specific portion of the video and its attribute elements contain associations (i.e., pointers, references etc.) with specific type, person, keyword, proposed keywords, and image attributes elements than may differ from other portions of the same video (see red arrows below). '014 Patent.

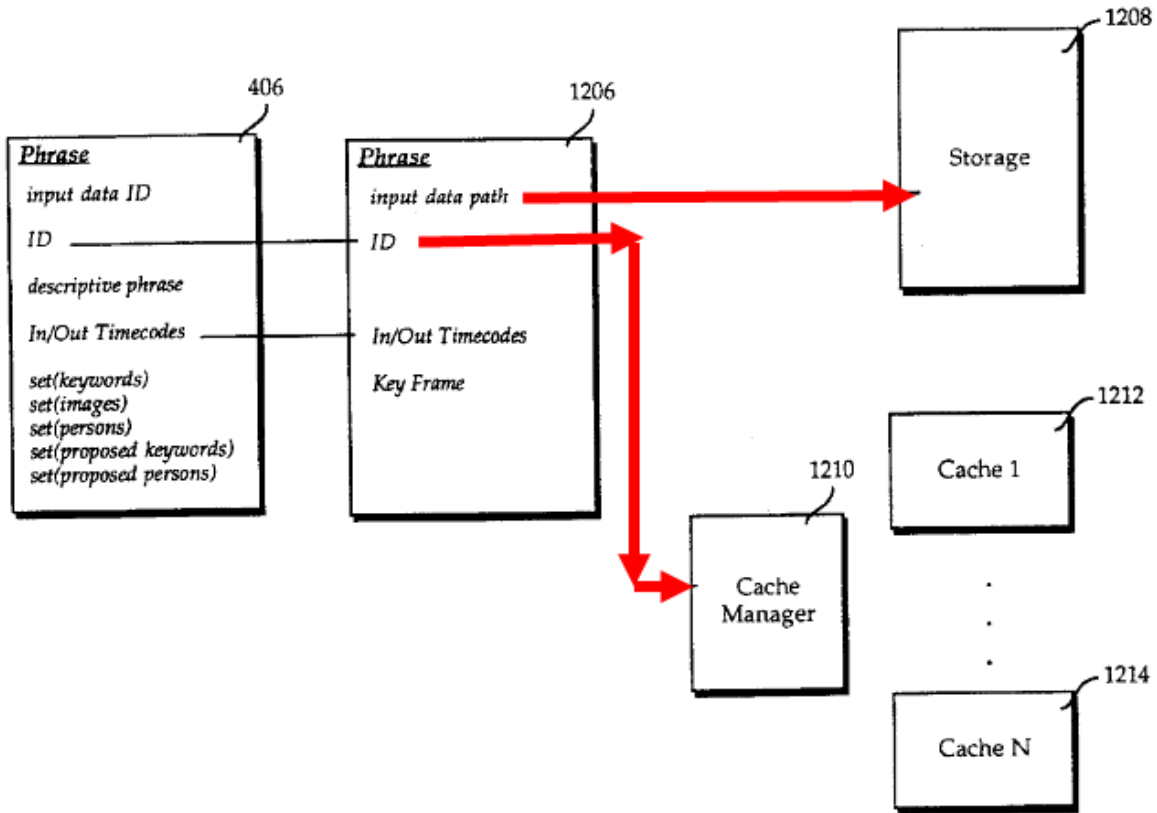

151. Another important unconventional feature of the particular phrase data structure used in the disclosed preferred embodiment that is critical to the 101 analysis is that it contains an unconventional pointer to the cache where the specific portion of video indexed by the phrase is stored (red arrow). This pointer is unique and differs from the prior art because it points to the location of portions of data so that the relevant portion may be actually retrieved from a cache and played. The association with the proper cache manager allows the location of the portion as it may be stored in temporary storage locations for efficient retrieval, processing speed, and bandwidth consumption.

152. As a whole, this unconventional data structure uses an unconventional pointer to associate information relevant to a memory location of a portion of video with the phrase element

so that the video portion may be retrieved. The attribute elements of the phrase further associate the memory location with phrase attributes such as type, person, or keyword that can be used to locate specific phrases or portions of video of interest. Thus, the unconventional phrase catalogue structure enables the system to identify and retrieve specific portions of multimedia data from stored memory locations by associating attributes identifying portions of the multimedia data with specific phrases:

The elements described can also be instantiated to catalogue multimedia data ...Catalogue B has a **plurality of instances of phrase 206 each associated with a portion of multimedia 60 data 1802B**. Each instance of phrase 206 has one or more attributes and/or attribute elements. **Attributes such as an in timecode and an out timecode identify a portion of the video from an event that is associated with an instance of phrase 206.**

'495 patent, 25:52-65. The inventive catalogue structure allowing the identification, search, and retrieval of specific portions of multimedia data as reflected in numerous claim limitations. For example, Claim 2 of the '495 patent describes a catalogue with the phrase data structure directed to indexing portions of video:

1. In a computer system, a method of cataloguing multimedia data comprising the steps of:
 creating a catalogue comprising a plurality of elements and relationships between said plurality of elements, said plurality of elements identifying data associated with said multimedia data, said data including keywords interrelated via one or more associative, whole-part and inheritance relationships, and other multimedia data associated with said multimedia data;
 specifying a **description for a portion of said multimedia data**;
 creating a catalogue element in said catalogue, said catalogue element containing **a pointer to said portion of said multimedia data**; and
 creating for said catalogue element a pointer to at least one of said keywords **[associations of portion with key word attribute]**, said at least one of said

keywords containing a plurality of pointers to a set of elements in said catalogue interrelated to said at least one of said keywords via said one or more associative **[key word attribute is associated with other catalogue elements]**, whole-part and inheritance relationships, and creating for said catalogue element a plurality of pointers to elements in said catalogue **that identify other multimedia data associated with said portion of multimedia data [relations with at least one other attribute than key word]** .

'495 Patent, Claim 1.

2. The method of claim 1 wherein said step of creating a pointer to at least one of said keywords further comprises the steps of:
identifying references to said at least one of said keywords in said description;
and
creating said pointer to at least one of said keywords for said catalogue element.
creating said pointer to at least one of said keywords for said catalogue element. '495 Patent, Claim 2.

Claim 10 of the '831 patent describe indexing and processing steps directed to “portions” of a multimedia file and its means plus function format incorporates limitations from the very detailed specification of the Catalogue:

10. A computer system for **cataloguing multimedia data** comprising:
a means for creating a **catalogue comprising a plurality of elements and relationships** between said plurality of elements, said plurality of elements identifying data associated with **said multimedia data**, said data including keywords interrelated via one or more associative, whole-part and inheritance relationships, and other multimedia data associated with said multimedia data;
a means for **specifying a description for a portion of said multimedia data**;
a means for creating a catalogue element in said catalogue, **said catalogue element containing a pointer to said portion of said multimedia data**; and

a means for creating for said catalogue element a pointer to at least one of said

keywords, said at least one of said keywords containing a plurality of pointers to a set of elements in said catalogue interrelated to said at least one of said keywords via said one or more associative, whole-part and inheritance relationships, and **creating for said catalogue element a plurality of pointers to elements in said catalogue that identify other multimedia data associated with said portion of multimedia data...**

'831 Patent, Claim 10.

153. '014 claim 14 recite explicit limitations directed to the cache pointer of the of a phrase:

13. The method of claim 1 wherein said step of retrieving further comprises the steps of: associating a plurality of identifiers (IDs) to said portion of said multimedia data; creating a pointers for each of said plurality of IDs, said physical storage pointer pointing to a location in which said portion of said multimedia data is stored; retrieving said plurality of IDs; retrieving said portion of said multimedia data from storage using said pointers.

14. The method of claim 1 wherein said step of retrieving further comprises the steps of: searching cache for said portion of said multimedia data; retrieving said portion of multimedia data into said cache from permanent storage, if said portion of multimedia data is resident on permanent storage and is not found in said cache.

Other claims also reflect cataloguing phrases directed to portions of multimedia.

154. The Phrase data structure claims recite a specific unconventional data structure that within the ordered combination of the remaining claim elements (representing inventive concepts) gives the system the unconventional capability of searching not just for a video file, but also within the given video file for specific portions of the video represented using the unconventional

Catalogue data representation corresponding to the search parameters. The claimed system thus has the ability to search for a particular portion of a larger video by associating catalogue elements with the portion of multimedia data (i.e., one or more frames of video data) using an unconventional data structure with an unconventional pointer. The claimed data structure and ordered combination represents a non-abstract “specific means” to provide a technical solution (using inventive concepts) to technical problems and therefore are a non-abstract and patent eligible “improvements to the computer functionality itself.”

D. Query and Search Result Caching Claims

i. Early Multimedia Systems Struggled with Problems with System Processing and Bandwidth Consumption

155. In 1996, computer processing costs, system congestion and bandwidth consumption were major problems to early multimedia systems. The resource consumption problems of content based searching are particularly acute with prior art multimedia systems:

Obviously, **full content data searching is better, but it is typically cost prohibitive in prior art systems**, because of the demands on system resources. **Therefore, there is a need in the art for an efficient full content data searching technique.** The technique should work with disparate content data sources and disparate content data types. The technique also should minimize search times by utilizing a build process to **pre-process the full content data to streamline searching during run-time operation.** The technique also should support natural word search queries and should use alternative search words and word pairs to increase the accuracy of search results and search

U.S. Patent application No. 2007/0282822 titled “Content data indexing with content associations” to Anderson et al.

Existing database technology is not designed to manage digital video ... These techniques are not suitable for very large collections of video, as they require a great deal of computational power and processing time.

Ahanger, G., Benson, D., and Little, T., Video Query Formation, Proc. Storage and Retrieval for Images and Video Databases III, IS&T/SPIE Symposium on Electronic Imaging Science &

Technology, vol. 2420, pp. 280-291, available at

<http://citeseerx.ist.psu.edu/viewdoc/download?doi=10.1.1.477.5252&rep=rep1&type=pdf>.

156. Similarly, problems associated with multimedia networks' consumption of bandwidth remained well into the 2000s and was considered "a challenge multimedia networking must face":

However, multimedia networking is not a trivial task. We can expect at least three difficulties. First, compared with traditional textual applications, multimedia applications usually require much higher bandwidth. A typical piece of 25 second 320x240 QuickTime movie could take 2.3MB, which is equivalent to about 1000 screens of textual data. **This is unimaginable in the old days when only textual data is transmitted on the net.**

Second, most multimedia applications require the real-time traffic. Audio and video data must be played back continuously at the rate they are sampled. If the data does not arrive in time, the playing back process will stop and human ears and eyes can easily pick up the artifact...Third, multimedia data stream is usually bursty. Just increasing the bandwidth will not solve the burstiness problem....Contrary to the high bandwidth, real-time and bursty traffic of multimedia data, in real life, networks are shared by thousands and millions of users, and have limited bandwidth, unpredictable delay and availability.

How to solve these conflicts is a challenge multimedia networking must face.

Liu, Multimedia Over IP: RSVP, RTP, RTCP, RTSP, http://www.cse.wustl.edu/~jain/cis788-97/ftp/ip_multimedia/#multi1 (emphasis added).

157. This was a particular problem to the claimed solution of the Shoah system because its architecture required multiple applications and system components operating over a network and full content based searching.

ii. *The Query and Search Result Caching Claims Represent a Technological Improvement to Address the Technical Problem of System Processing and Bandwidth Consumption*

158. The Patents-in-Suit attempted to address the system and bandwidth consumption limitations of prior arts systems by using pre-processed search results. Pre-processing all queries is an impractical task. The system used prior search history saved within the catalogue as a proxy

for the most important queries to pre-process. By doing so, the system removes the inefficiency of repeated duplicate or similar search queries—thereby lessening the consumption of system resources and bandwidth (between multimedia components over a network) and reducing response times. Unlike prior art systems, the claimed catalogue caches queries and search results so there is no need to repeat a search:

The invention **stores previous searches and the results of the previous searches**. The **results of a search form a sub-catalogue**, or collection of catalogue elements. Thus, when a search is entered, **processing determines whether the search has already been performed**. If so, the search results are retrieved. Therefore, **there is no need to repeat a search**. If the search is a new search, browser 318 performs the search. When search input is received, browser 318 determines the type of search requested and initiates the search.

'014 patent, 16:42-51. The Shoah patents claim the feature of a specific sub-catalogue data structure that associates previous searches with specific data representations of queries. This sub-catalogue caches both (1) the previous query and (2) the previous results of that search. The claimed search algorithms queries the catalogue to identify previous queries on the catalogue so as to avoid having to re-run the search—thereby creating benefits with respect to reducing bandwidth and system processing costs.

iii. The Query and Search Result Caching Claims Provide a Specific Technological Solution to the Problem through Use of an Inventive “Catalogue” Data Structure for Caching Prior Search Queries

159. The query and search result caching claims are not merely addressed to the idea of a more efficient system or even the pre-processing of search results. Rather, the patents explain and the claims claim a specific technological means and data structures for achieving the technological improvement and are therefore non-abstract.

160. The patents explain that its unconventional “catalogue” data structure attributes contained within the indexing sever of the claimed system will be used to store prior search results:

The invention **stores previous searches and the results of the previous searches**. The **results of a search form a sub-catalogue**, or collection of catalogue elements. Thus, when

a search is entered, **processing determines whether the search has already been performed.** If so, the search results are retrieved. Therefore, **there is no need to repeat a search.** If the search is a new search, browser 318 performs the search. When search input is received, browser 318 determines whether a the type of search requested and initiates the search.

Query elements and objects are used to facilitate search operations. They retain information about a search. **Preferably, the information retained is, for example, the search criteria and the search results. The criteria that is retained for a search can be used to compare against criteria specified for a subsequent search.** If a match is found, the retained search results can be used to satisfy the current search. **Thus, there is no need to duplicate a search.** Query relations are stored on indexing server 316 in addition to the catalogue and attribute elements to retain search criteria. In addition, an instance of segment 404 is created to retain the results of a search. FIG. 11 illustrates elements and element relationships for processing and retaining search requests according to an embodiment of the invention.

'014 patent, 16:42-51, 20:25-39.

161. The invention utilizes a unconventional multimedia data structure referred to as a “segment element” to identify and store the results of a search and also to relationally link prior search queries and results:

A segment element is used to store the results of a search. A segment element is a multimedia asset. Thus, for example, when a set of catalogue elements is identified from a search operation, a segment element is instantiated. An attribute element of the segment element contains each catalogue element identified in the search operation. A relationship is formed between the segment element and a query instance.

'014 patent, 5:44-51.

162. Figure 4A shows an example format of “segment element” data structure 404:

The “segment element” is relationally identified with another inventive data structure, the

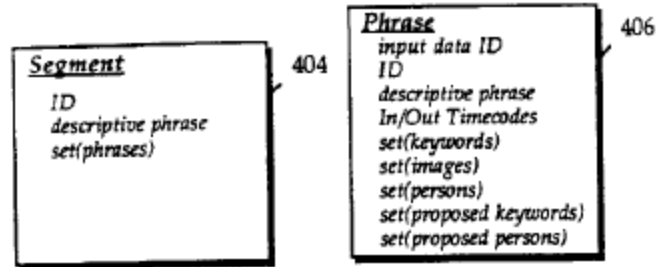

“catalogue element”, which may contain pointer identifiers to portions of multimedia data that satisfies the search:

A catalogue element is associated with a portion of multimedia data (e.g., one or more frames of video data). The result of a search operation performed by the browser identifies a set of catalogue elements that can satisfy a search request. Each catalogue element has an associated identifier (ID) (e.g., an integer ID) that uniquely identifies the catalogue element. A set of IDs that represent the set of catalogue elements identified in a search operation are sent to the archive server component for retrieval of the associated multimedia data.

'014 patent, 5:24-34. The associated algorithms that creates the segment elements and stores prior search results are shown by the Patents-in-Suit, including Figs. 7A and 7B:

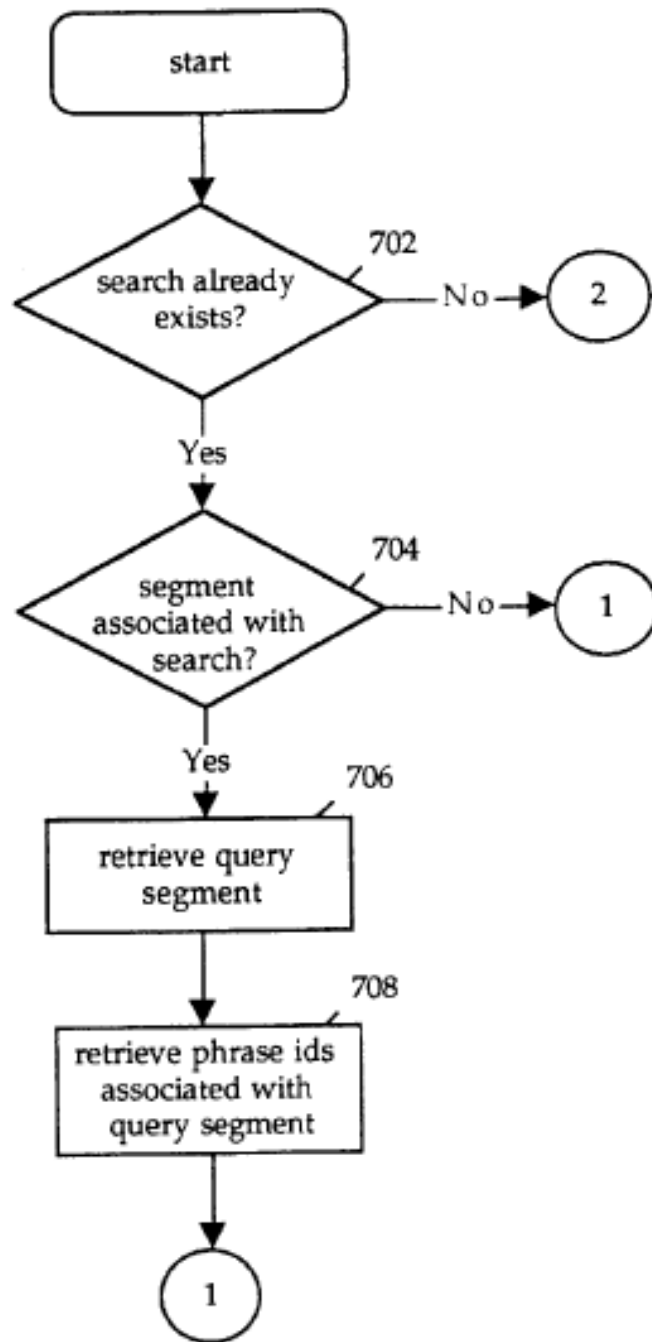

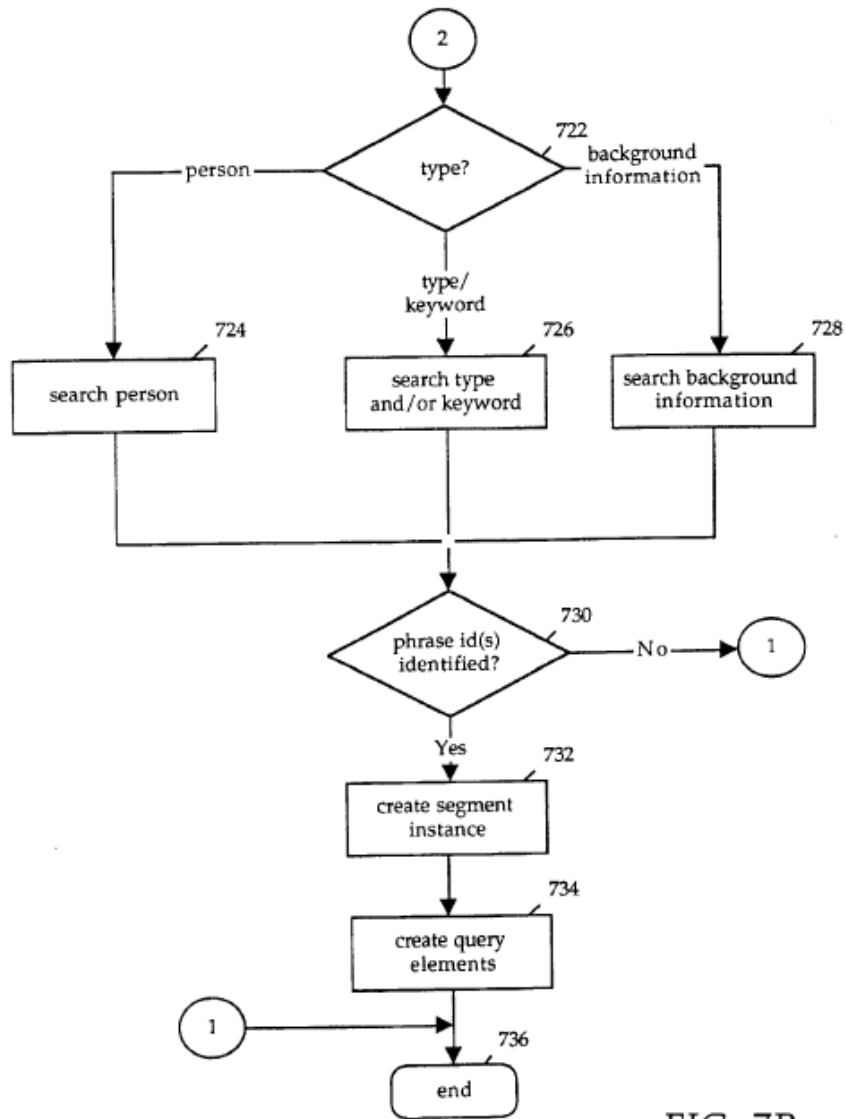

FIG. 7B

The relationships between segment elements (404) and their relationships through keywords and other associations are shown in Figs. 4B and 11B:

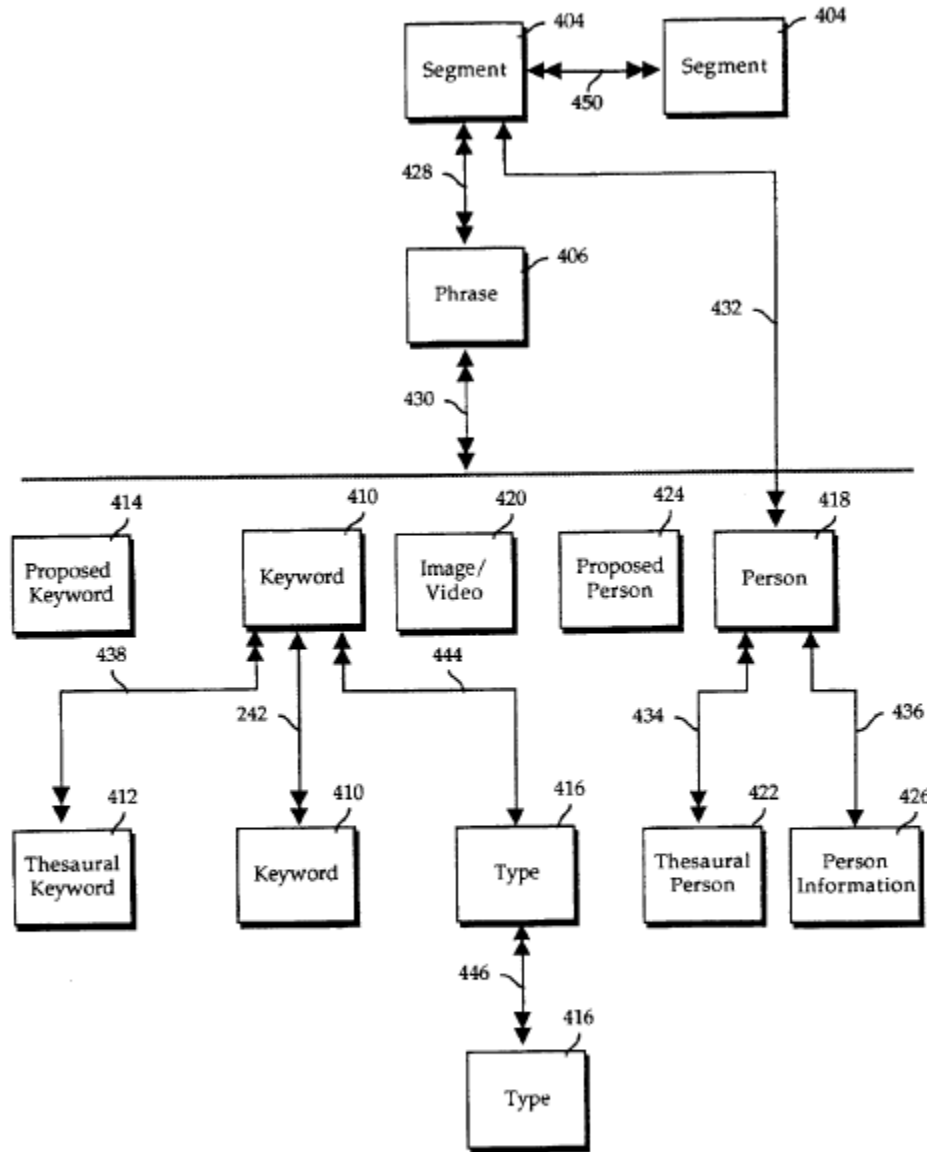
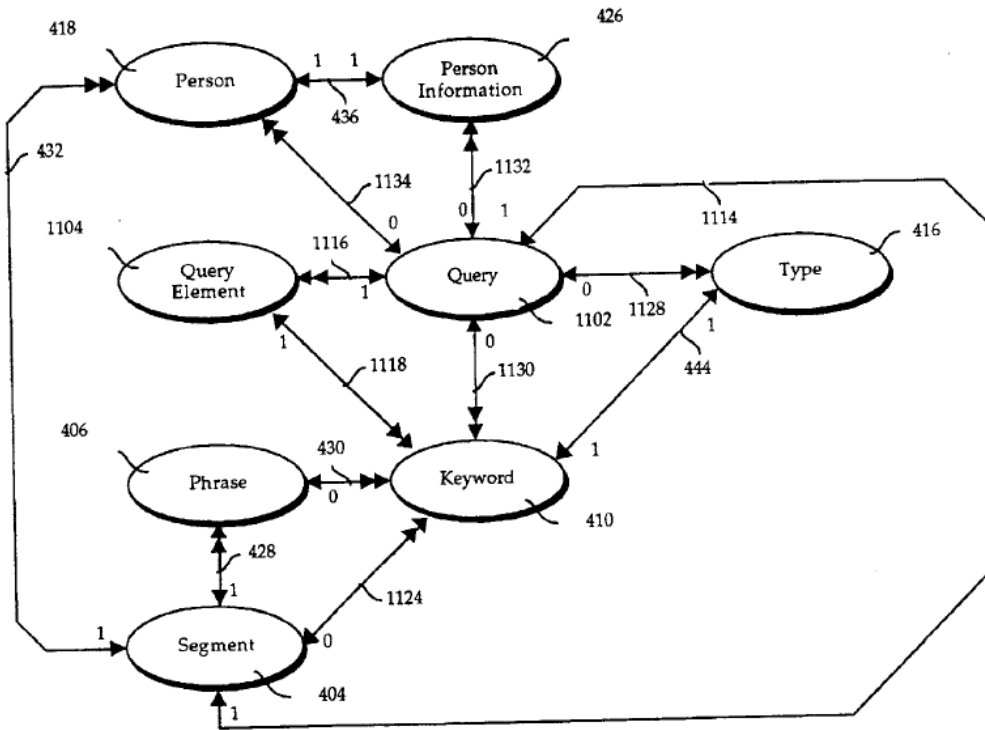

FIG. 4B



The interrelationships between segment elements 404 via keyword associations and other types of associations show the self-referential nature of the catalogue (i.e., segment elements within the catalogue refer to other elements in the catalogue).

163. The improvements and inventive data structures discussed above are embodied in, for example, claim 21 of the '014 patent, which claim storing a “search request” and the “result of said search request” in the catalogue data structure:

21. An article of manufacture comprising:

a computer usable medium having computer readable program code embodied therein for accessing multimedia data, the computer readable program code in said article of manufacture comprising:

computer readable program code configured to cause a computer to define a catalogue for said multimedia data having a plurality of catalogue elements each of which is

associated with a portion of said multimedia data, said plurality of catalogue elements associated with a plurality of keywords of said catalogue, said plurality of keywords identifying said multimedia data, said plurality of keywords being interrelated by one or more of associative, whole-part and inheritance relationships:

computer readable program code configured to cause a computer to specify a search request;

computer readable program code configured to cause a computer to identify a result of said search request that satisfies said search request, said result containing one or more of said plurality of catalogue elements;

computer readable program code configured to cause a computer to retrieve said portion of said multimedia data associated with said one or more of said plurality of catalogue elements;

computer readable program code configured to cause a computer to store in said catalogue said search request; and computer readable program code configured to cause a computer to store in said catalogue said search result. **[A catalogue with stored prior queries and search results as catalogue elements]**

22. The article of manufacture of claim 21 further comprises:

computer readable program code configured to cause a computer to specify a second search request;

computer readable program code configured to cause a computer to compare said second search request with said search request;

computer readable program code configured to cause a computer to retrieve said search result when said second search request is the same as said search request **[Use of the pre-processed search result to eliminate duplicate searching]**.

23. The article of manufacture of claim 21 wherein said search request is comprised of one or more elements, said computer readable program code configured to cause a computer to store said search request further comprises:

computer readable program code configured to cause a computer to store said one or more elements; and

computer readable program code configured to cause a computer to store cardinality information for said one or more elements; and computer readable program code configured to cause a computer to store conjunctivity information for said one or more elements **[claiming of query representation data structure]**.

24. The article of manufacture of claim 21 wherein said computer readable program code configured to cause a computer to store said search result further comprises:

computer readable program code configured to cause a computer to create a container element; and

computer readable program code configured to cause a computer to create a relationship between said container element and said one or more of said catalogue elements **[use of a segment in catalogue to store search results]**.

Other claims from additional Patents-in-Suit also reflect this structure. Thus, the claimed catalogue is a specific data structure that improves the functionality of the catalogue by improving user searches by caching the queries and results of previous searches. The claims require a specific “catalogue” that stores both a previous search request and a previous search result associated with that search request in a manner that improves future searches using the data cached within the sub-catalogue, and therefore reflect a non-abstract technical improvement. These claims further reflect an unconventional, non-routine and not well understood solution and data structures that embody inventive concepts.

164. As the specification discloses, this clearly contrasts with existing data structures that did not use this inventive data structure or include a sub-catalogue of previous search requests and search results and thus could not use the data structure to facilitate future searches and address the bandwidth and system consumption issues in the manner of the claimed solution.

165. Plaintiff presented this specific technological improvement with inventive concepts to the PTO during prosecution and argued “[the prior art] does not teach, suggest or describe storing said search request or search result in a catalogue as in the claimed invention.” Response dated March 5, 1998 in Application No. 08/678,727 at 19 (attached hereto as “**Exhibit 6**”). In allowing the claims, the examiner agreed that caching search requests and caching search results within the catalogue were both new features not previously found in the art thereby providing further confirmation of the unconventionality and the presence of inventive concepts in the above claimed technical solution:

These limitations in conjunction with other limitations [i.e., storing said search request or search result in a catalogue as in the claimed invention] of the dependent and independent claims were not shown by, would not have been obvious over, nor would have been fairly suggested by the prior art made of record.

Office Action dated March 2, 1998 in Application No. 08/678,727 at 2-3 (attached hereto as “**Exhibit 6**”).

166. Thus, the patent’s inventive concept embedded in the improved catalogue solves the problem of determining what search results to preprocess by using the prior history of searches as a proxy for the most important searches to pre-process. The catalogue structure also stores prior search results so that they can be used to further improve the associations and attributes in the catalogue to improve future searches. ’014 patent, 16:42-51, 20:25-39. The improved and unconventional Catalogue Data Structure and associations discussed above represent a specific technological means for less consumption of processing resources and quicker response times; and therefore is a non-abstract technological improvement to the functioning of the computer itself.

167. Other claims of the patents further elaborate on even more specific details of the Catalogue data structure in this regard by describing the unconventional “segment” data structure

found within the catalogue storing search processing results. A segment data structure is described generally as:

Segment 404 is a container element. It can contain other elements. For example, Segment 404 can contain one or more instances of phrase 406. In the invention, input data is decomposed into one or more pieces, or fragments. An instance of phrase 406 is associated with each input data fragment. Phrase 406 is a catalogue element. Phrase 406 has one or more attributes and/or attribute elements on which an index is built. The index can be used to navigate through the catalogue.

'014 patent, 9:27-35. A segment container for storing search results is described as:

A segment element is used to store the results of a search. Thus, for example, when a set of catalogue elements is identified from a search operation, a segment element is instantiated. An attribute element of the segment element contains each catalogue element identified in the search operation. A relationship is formed between the segment element and a query instance.

'014 patent, 5:44-50. The data structure for representing a prior search query is described here:

The invention retains the content and results of a search such that it is only necessary to perform a search once. Thereafter, the results of the search can be retrieved without performing the search. Search elements are used to store the content of a search, i.e., search criteria. Search elements include a query and a query element. Query element instances contain the search criteria. A query instance identifies a particular query. A query instance can contain one or more query element instances.

'014 patent, 5:35-43.

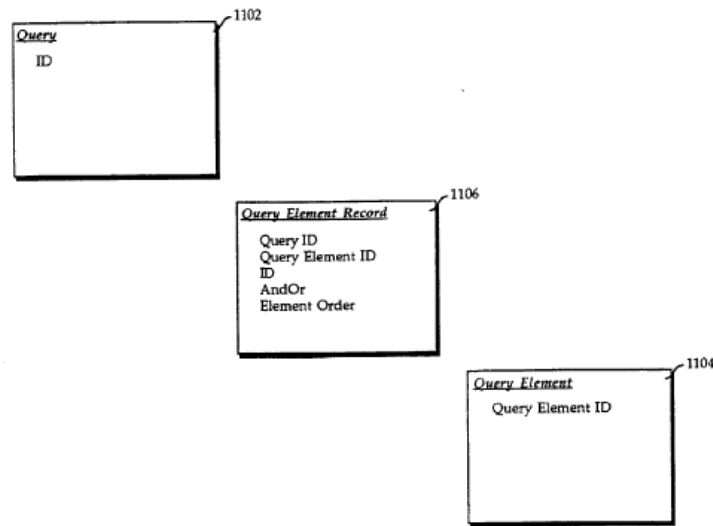

FIG. 11B

Detailed specifics of the query representation as attribute elements are explicitly claimed in, for example, '014 patent, claim 3:

3. The method of claim 1 wherein said search request is comprised of one or more elements, the step of storing said search request further comprises the steps of:
 storing said one or more elements; and
 storing cardinality information for said one or more elements; and
 storing conjunctivity information for said one or more elements.

See also '014 patent, claim 23.

168. The patent embodiment describes the use of the segment container within the catalogue and the associative self-referencing relationships and attribute elements of the Catalogue to associate particular results with a particular query so that prior searches can be retrieved:

Thus, the criteria for a search can be recreated and compared to a new set of search criteria. **If a match is found, the instance of query 1102 associated with the match can be used to find its associated instance of segment 404 (via relationship 1114). The instances of phrase 406 associated with the instance of segment 404 (via relationship 428) can then be identified.** If a match is not found, a search can be performed to identify a new instance of segment 404 and its associated instances of phrase 406.

'014 patent, 21:20-28.

At step 702 (i.e., “search already exists?”), a determination is made whether the search specified in the input already exists. If the search already exists, processing continues at step 704 to identify the instance of segment 404 that was created for the search. If no instance of segment 404 is found, processing ends at step 736. If an instance of segment 404 is found, processing continues at step 706 to retrieve it. At step 708, the instances of phrase 406 associated with the segment instance are identified (e.g., the associated phrase ids are retrieved from indexing server 316 using Get_Phrases_In_Segment routine in Segment group 512 of interface 314). Processing ends at step 736.

'014 patent, 16:52-63.

169. The use of segment containers and catalogue elements in query and keyword (and other) associations is explicitly claimed. '014 claims 3, 4 and 24 describe further limitations of the search caching algorithm of claims 1 and 21, including creating the inventive “segment” data structure (i.e., the “container element”) data structure for storing search results:

4. The method of claim 1 wherein said step of storing said search result further comprises the steps of:
creating a container element; and

creating a relationship between said container element and said one or more of said catalogue elements.

24. The article of manufacture of claim 21 wherein said computer readable program code configured to cause a computer to store said search result further comprises:

computer readable program code configured to cause a computer to create a container element; and

computer readable program code configured to cause a computer to create a relationship between said container element and said one or more of said catalogue elements.

170. Claims 10 and 11 provide additional further limitations. Claim 11 in particular require identifying keyword associations between catalogue elements (the results of previous searches). A keyword association between catalogue elements may represent a self-referential relationship within the catalogue (i.e., a catalogue element that refers to another catalogue element in the catalogue):

10. The method of claim 1 wherein said step of identifying further comprises the steps of: identifying a plurality of person instances using said search request;

identifying a plurality of container elements related to said plurality of person instances; and

identifying a plurality of catalogue elements related to said plurality of container element instances.

11. The method of claim 10 further comprising the steps of:

identifying a plurality of keywords associated with one of said plurality of catalogue elements;

examining said plurality of keywords to determine whether said one of said plurality of catalogue elements satisfies content criteria specified in said search request; and

including said one of said plurality of catalogue elements in a set of catalogue elements when said content criteria is satisfied.

171. Other claims directed to search caching include claims 5 and 6 of the '638 patent reciting use of survey data with the “phrase” data structure:

5. The method of claim 2 wherein said at least one attribute identifies at least one segment element of said catalogue.
6. The method of claim 1 wherein said catalogue element is a phrase element.

Other claims from additional Patents-in-Suit also reflect the above described features.

172. Thus, these claims which further elaborate on the unconventional, non-routine, and not well understood data structures used to cache search results claim further inventive concepts used within an unconventional ordered combination of claim limitations that provide a non-abstract technical solution (including the inventive concepts described above) to the technical problems of bandwidth and system processing resource consumption. They provide the specific, therefore non-abstract, technological means in terms of improved data structures and processing for reducing bandwidth and resource consumption rather than merely being directed to a desirable but abstract result.

E. Video Caching Claims

- i. The Video Caching Claims Address the Problem of Bandwidth and System Resource Consumption by Improved Storage of Multimedia Data*

173. The video caching claims represent a further technological improvement to prior art systems designed to address bandwidth and system processing limitations of prior art multimedia systems described above. These claims provide limitations directed to an improved architecture of storage systems and the use of the improved catalogue described above that caches search results to reduce system processing and bandwidth consumption as well as response times and efficient delivery.

174. In addition to improving multimedia search functionality by caching search queries and their results in the catalogue, the Shoah patents also store the underlying videos that are identified as search results (i.e. specific portions of videos responsive to a search) in a two tier architecture using local caches and remote caches. The patents recognize that prior art systems retrieved complete videos from magnetic tape systems, optical discs, and other forms of permanent storage:

An image data filing system consisting of a library for storing a plurality of image storage media (e.g., optical disks), a disk array for storing image data retrieved from the image storage media, a console for entering user instructions, and an output device for displaying image data is described in U.S. Pat. No. 5,463,771, Sotoyanagi et al., issued on Oct. 31, 1995. A control device is used to control the retrieval and storage operations. '499 Patent, 4:3-10.

175. The patents identify a problem of these prior art systems' retrieving multimedia from permanent storage as that this retrieval is inefficient, slow, and processing intensive ("retrieval time is fastest when the data is retrieved from cache (either local or remote). When a tape system must be accessed to retrieve the data, retrieval time will most likely be slower") and propose to solve this problem by storing the videos identified in a previous search in remote and local caches to improve retrieval time and search processing efficiency:

In addition, **the invention uses one or more instances of cache to temporarily store the multimedia data.** Cache manager 1210 manages one or more caches (cache 1 through cache N). Cache I-N are one terabyte (Th) caches, for example. '014 Patent, 21:57-61.

The multimedia data is permanently stored at a main site with copies of data that has accessed stored at the user's site. The local catalogue is accessed to identify the data

requested in a user request. If a copy of the requested data does not exist at the local site, a search is made for the data at another site. The search first examines the cache at the other sites. If the data cannot be found in cache at the local or another site. The local site accesses the main site to retrieve the requested data. A vehicle such as a WAN or the Internet can be used to transmit the data between sites.

'499 Patent, 13:11-21. Retrieval is further improved using a cache management system that allows for faster access than permanent storage solutions:

Cache Management

Preferably, cache management is supplied by an instance of tertiary storage manager 204. The instance of **tertiary storage manager 204 that manages the data denormalizes the data allowing for faster access**. Tertiary storage manager 204 that manages cache 244 uses a least recently used (LRU) scheme. Thus, multimedia data that has the oldest access time is purged to make room for newly accessed data.

'499 Patent, 10:51-11:31.

ii. *The Video Caching Claims Provide a Particularized Technological Solution to the Multimedia Storage Problem Through Use of a Novel Data Structure for Storing Specific Requested Portions of Multimedia Data Referenced by Pointers in the Sub-Catalogue*

176. The patents disclose several technological solutions to the problem of inefficient retrieval from permanent storage. The patents disclose a two-tier caching structure using remote and local caches to improve retrieval efficiency, as shown in Fig. 2:

177. The inventive system includes a series of local caches 1 through N (at 244), a

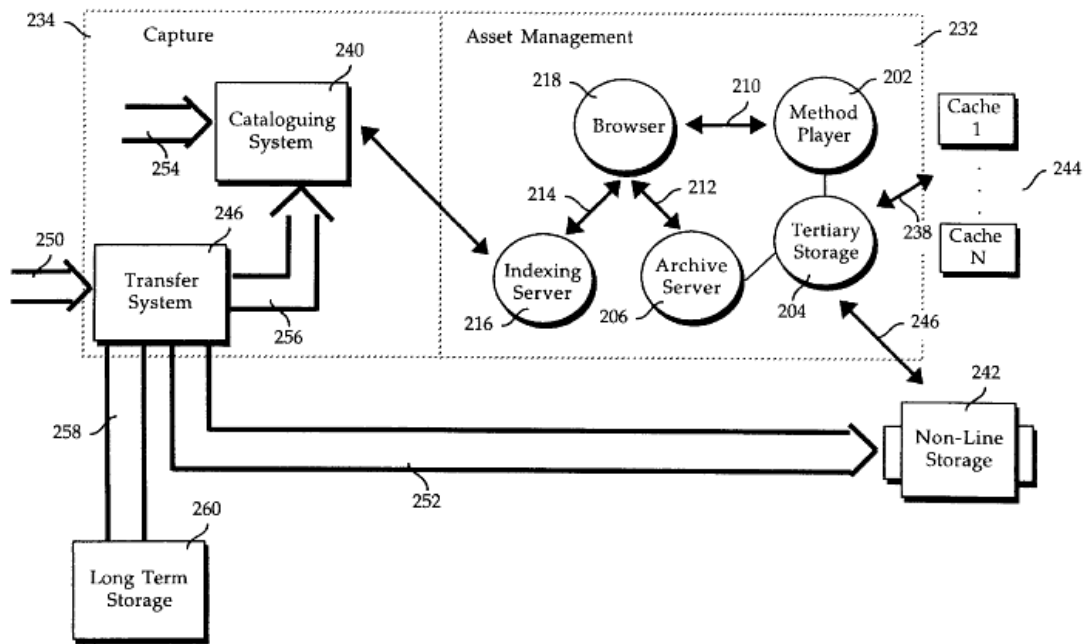

Figure 2

remote cache (at 260), and if necessary permanent storage (at 242). By caching search results (portions of multimedia data responsive to a search query) in a tiered system using remote and local caches, the system provides a technological improvement to prior systems that only retrieved multimedia data from tape systems and other forms of permanent storage:

The multimedia data associated with catalogue elements can be **retrieved from offline storage such as a tape system**. The invention also provides the ability to **temporarily**

store multimedia data in cache such as cache 244 in FIG. 2. Cache can be local (i.e., cache that resides at the local site) or remote (i.e., cache at a remote site). In most cases, **retrieval time is fastest when the data is retrieved from cache (either local or remote). When a tape system must be accessed to retrieve the data, retrieval time will most likely be slower. Therefore, it is preferable to determine whether the data is resident in cache before accessing a storage system such as a tape system. Further, it is preferable to manage the cache such that the data that is most likely to be needed is resident in cache.**

'499 Patent, 11:-14.

178. The patent provides an algorithm for retrieving multimedia data from the two-tier cache system by first searching in the local cache and, only if the data is not found, repeating the search on the remote cache and finally searching permanent storage, as shown in Fig. 4:

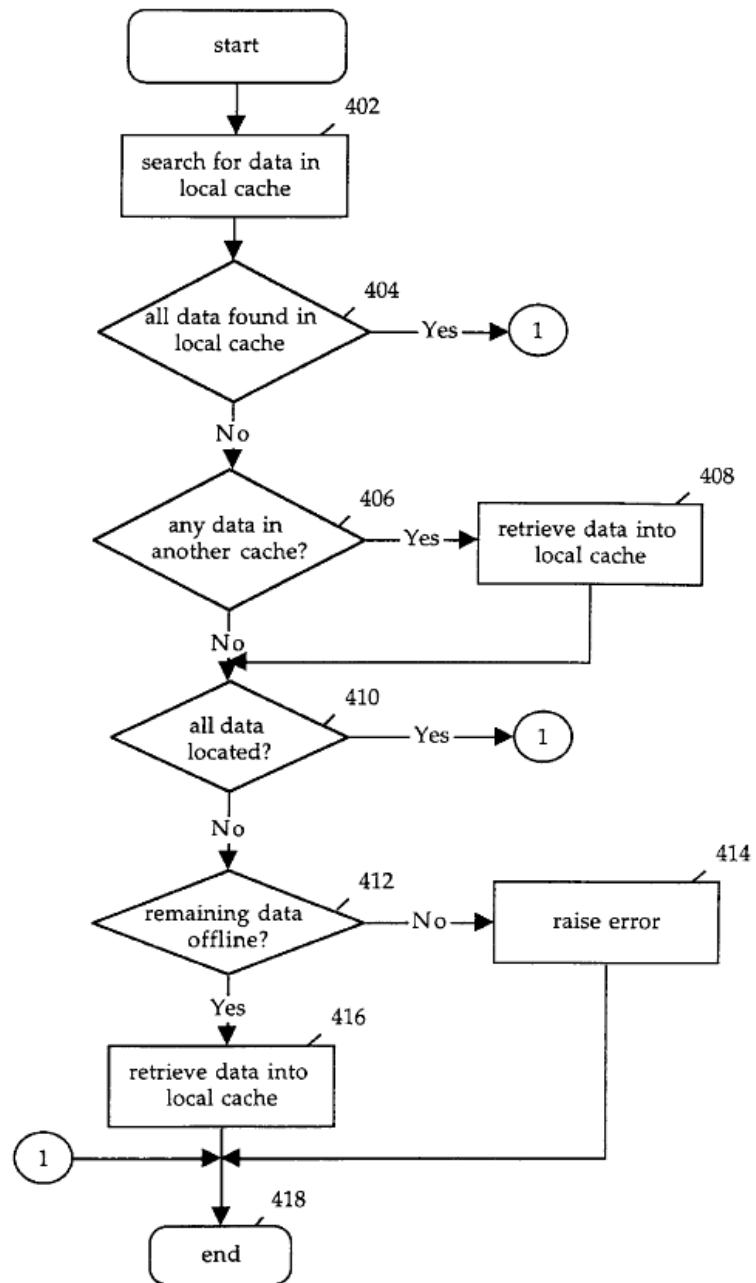

Figure 4

179. The patents further disclose using “named caches” to store frequently requested multimedia data on a semi-permanent basis to reduce the need to retrieve multimedia data from permanent storage:

Named Cache

In addition to the regular cache that can be managed as discussed above, the invention includes a plurality of named caches. **A named cache can be used to store data on a more permanent basis. A named cache is a portion of cache (e.g., cache 318) that is can be managed separate from the general cache pool. A named cache may be used for data that is accessed or has the potential for access on a more permanent basis. For example, one or more searches can yield a sub-catalogue (e.g., a subset of the set of catalogue elements associated with multimedia data 252) that contains data pertinent to a particular subject area or group of users. The named cache can be used to store the portions of multimedia data 252 associated with the sub-catalogue at a remote site such that it is not purged despite its LRU statistics.** The portions of multimedia data 252 associated with a sub-catalogue can be retained permanently or semi-permanently. That is, the contents of the named cache can be retained for a specified period of time and is not subject to purge.

'499 patent, 12:27-45. The named cache identified by the catalogue solves the problem of retrieval from permanent storage by providing a semi-permanent storage location for multimedia data that is still more accessible than permanent storage devices such as magnetic tapes or optical discs. Thus, the named cache further reduces the need to retrieve multimedia data from permanent storage even for systems utilizing smaller caches.

180. The Patents disclose a specific data structure for search result caching in the catalogue illustrated for example by Fig. 12:

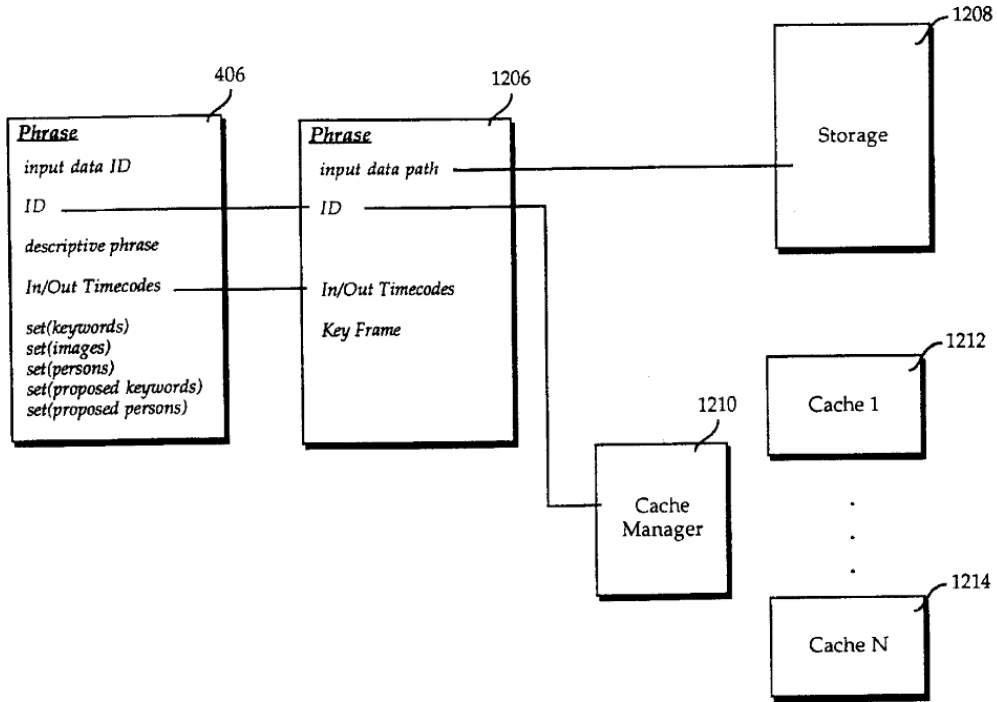

181. This data structure of Fig. 12 is utilized to cache specific portions of multimedia data and how the portions are associated with specific phrases in the catalogue (and identified by pointers) to facilitate retrieval from the caches:

FIG. 12 illustrates use of the phrase element to access multimedia data in accordance with an embodiment of the invention.

Phrase 406 is an attribute element that is associated with a portion of multimedia data. Phrase 406 has ID and timecode attributes. A corresponding instance of phrase is maintained by archive server 306, i.e., phrase 1206. Phrase 1206 has an ID that corresponds with the ID of its counterpart instance of phrase 406. Similarly, the timecode attributes of phrase 1206 correspond to the timecode attributes of phrase 406. In addition, phrase 1206 has a path attribute that points to the physical storage location of the portion of multimedia data associated with phrase 1206 (and 406).

The input data path attribute of phrase 1206 can be used to load the multimedia data from a storage device. Multimedia data is permanently stored in storage 1208 (e.g., a tape system such as a provided by EMASS). In addition, the invention uses one or more instances of cache to temporarily store the multimedia data. Cache manager 1210 manages one or more caches (cache 1 through cache N). Cache 1-N are one terabyte (Th) caches, for example.

'014 Patent, 6:62-64, 21:43-53. The disclosed data structure enables the local cache to store the videos identified in the catalogue as a prior search result relevant (portions of multimedia data responsive to a search query) without overloading cache storage with all the multimedia data that may be found in permanent storage by storing only the portions responsive to the query. This is accomplished by using the "phrase element" and "segment" data structures of the Catalogue to identify the portion of multimedia data responsive to the search, and storing the identified portion of multimedia data in the local cache.

182. The system stores data in multiple caches and the system is capable of searching all the caches for multimedia data corresponding to the search. Only if not all of the multimedia data is found within the caches, the system will query additional locations such as permanent storage: **"Archive server 206 determines whether the portion of cache 244 resident at the same site (i.e., local cache) contains the multimedia data associated with the catalogue elements.** If the multimedia data is not stored in local cache, the archive server can query other archive servers to determine whether the data is stored in the portion of cache 244 that resides at the other site (i.e., remote cache). If the archive server cannot find a copy of the data in cache 244, it will attempt to retrieve the data from permanent storage (e.g., non-line storage 242)." '499 patent, 11:20-31. FIG. 4 provides a process flow for cache management and retrieval according to an embodiment of the invention.

183. The inventive two-tier architecture disclosed by the patent is reflected in the claims. For example, claim 7 of the '080 patent and dependents describe the improved architecture of the inventive multi-tiered caching system by specifying “a plurality of remote sites compris[ing] temporary storage for some or all of said multimedia data” where the temporary storage “is a cache” and “is a named cache”:

7. The system of claim 1 wherein said distribution system further comprises:
a main site wherein said main site comprises permanent storage for the multimedia data in said digital library system; and
a plurality of remote sites coupled to said main site wherein said remote sites comprise temporary storage for some or all of said multimedia data in said digital library system.

10. The system of claim 7 wherein said temporary storage is a cache.

11. The system of claim 7 wherein said temporary storage is a named cache.

184. Claim 13 of the '499 patent which recites the local and remote caches and further recites using phrase catalogue elements (The multimedia data catalogue used in the invention preferably consists of one catalogue element that is referred to as a phrase) to retrieve the specific portions of multimedia data responsive to the search from the caches:

13. A method of retrieving data in a digital library system comprising the steps of:
searching a local cache for a portion of multimedia data stored in said digital library system, digital library system having a catalogue of said multimedia data comprising at least one catalogue element associated with a plurality of keywords of said catalogue, said plurality of keywords identifying said portion of said multimedia data, said plurality of keywords being interrelated by one or more of associative, whole-part and inheritance relationships;

retrieving said portion of multimedia data into said local cache from a remote cache, if said portion of multimedia data is resident in said remote cache and is not found in said local cache;

retrieving said portion of multimedia data into said local cache from permanent storage, if said portion of multimedia data is resident on permanent storage and is not found in said local cache or said remote cache.

Thus, the improved catalogue of catalogue elements that specifies the cache as an attribute represents patent eligible programmable characteristics configuring a cache.

185. Dependent claim 15 recites the use of named caches to store frequently requested multimedia data on a semi-permanent basis:

15. The method of claim 14 wherein said step of determining further comprises the steps of:

determining whether said cache contains information that is currently being used;

determining whether said cache contains information that is marked for semi-permanent retention;

freeing said cache, if said cache does not contain information currently in use and said cache is not marked for semi-permanent retention.

186. The same technological improvements of the two-tier remote and local cache architecture, use of the phrase catalogue element data structure to identify specific responsive search results (portions of multimedia data), and use of named caches reference in the catalogue to store frequently requested multimedia data semi-permanently is similarly found in '014 patent claims 16-18:

16. An article of manufacture comprising:

a computer usable medium having computer readable program code embodied therein for retrieving data in a digital library system, the computer readable program code in said article of manufacture comprising:

computer readable program code configured to cause a computer to search a local cache for a portion of multimedia data stored in said digital library system, said digital library system having a catalogue of said multimedia data comprising at least one catalogue element associated with a plurality of keywords of said catalogue, said plurality of keywords identifying said portion of said multimedia data, said plurality of keywords being interrelated by one or more of associative, whole-part and inheritance relationships;

computer readable program code configured to cause a computer to retrieve said portion of multimedia data into said local cache from a remote cache, if said portion of multimedia data is resident in said remote cache and is not found in said local cache;

computer readable program code configured to cause a computer to retrieve said portion of multimedia data into said local cache from permanent storage, if said portion of multimedia data is resident on permanent storage and is not found in said local cache or said remote cache.

17. The article of manufacture of claim 16 wherein said program code configured to cause a computer to retrieve into local cache further comprises:

computer readable program code configured to cause a computer to determine whether there is space available in said local cache for said portion of multimedia data;

computer readable program code configured to cause a computer to free space in said local cache for said portion of multimedia data, if there is not enough space available;

computer readable program code configured to cause a computer to update cache management information.

18. The article of manufacture of claim 17 wherein said program code configured to cause a computer to determine further comprises:

computer readable program code configured to cause a computer to determine whether said cache contains information that is currently being used;

computer readable program code configured to cause a computer to determine whether said cache contains information that is marked for semi-permanent retention;

computer readable program code configured to cause a computer to free said cache, if said cache does not contain information currently in use and said cache is not marked for semi-permanent retention.

Other claims from additional Patents-in-Suit also reflect the above described features. In addition to implicating portions and cataloguing search results which provide independent bases of patentability, the video caching claims are patent eligible because directed to a specific implementation to computer technology rather than merely the abstract idea of improving bandwidth or even caching itself.

187. The patent sets forth and claims a specific architecture of multimedia components and storage systems using multiple caches to store portions of multimedia data and an algorithm for retrieving portions of multimedia related to a specific search request from the caches. It describes specialized data structures (i.e., the improved catalogue) that represent programmable characteristics of the cache. This system dramatically improves multimedia retrieval from prior art systems by storing (1) videos in local caches (2) relevant to prior search request and results to improve response times, delivery, and system processing and bandwidth consumption. Indeed, the “cache” implementation stores portions of multimedia data associated with particular “catalogues” of previous search requests to facilitate the retrieval of portions of multimedia data associated with past searches. The Video Caching claims in turn represent a non-abstract technical solution to a technical limitation of the art. The claims specify a particularized technical means (architecture; data structures; and processing steps using the aforementioned) for achieving an improvement to existing technology rather than being directed merely to an abstract idea of a

desirable result. The above described claimed features also represent an unconventional, non-routine, not well understood solution that contain inventive concepts that render the claims patent eligible.

VII. DEFENDANTS' ACTS

188. The infringing Defendants systems, articles, and methods include, but are not limited to, systems, articles, and methods relating to the cataloguing, organizing, searching, rating, and provisioning of digital multimedia data, including but not limited to Defendants' software and hardware supporting various Internet websites for streaming video, and related home and mobile device specific applications, including as set forth in Plaintiff's forthcoming infringement contentions and any amendments thereto (the "Accused Systems"). The Accused Systems, among other things, puts into use components from other parties (such as CDNs and customers) that infringe the Patents-in-Suit as set forth below. Preservation alleges infringement of the Asserted Patents by the Accused Systems by all websites (including premium versions) operated by or for the Defendants that use, without limitation, the following platforms (and all other websites operated by or on behalf of the Defendants that use similar domains, systems, platforms and/or protocols) collectively referred to herein as "the Accused Websites":

- www.xvideos.com ("XVideos") and www.xvideos.red (XVideos Red)
- www xnxx.com ("XNXX") and www xnxx.gold (SNXX Gold)
- www.bangbros.com ("Bangbros")
- www.penthouse.com ("Penthouse")

189. Defendants' Accused Websites represent an exemplary and non-exhaustive list of the websites owned and operated by WGCZ.

190. Customers who download, use, or put into use Defendants' software, applications, and/or mobile applications in accordance with Defendants' provided instructions also engage in infringing activity as described above. Defendants' software and servers also use, instruct and control components owned by Defendants and third parties.

191. Defendants actively target the United States jurisdiction and encourage United States citizens to join as members.

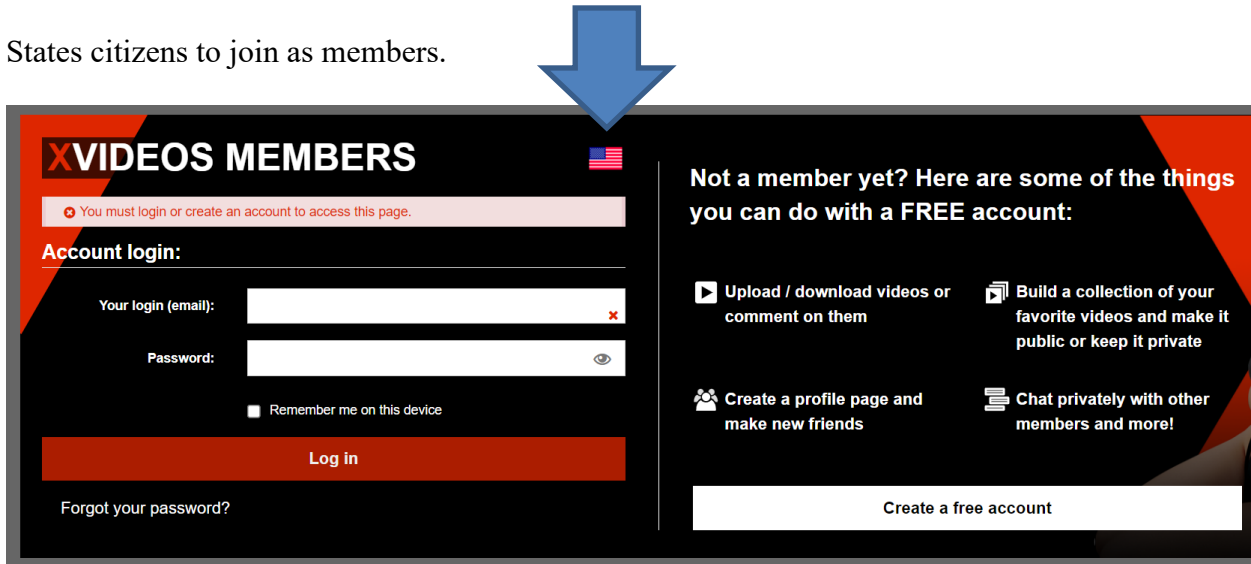

<https://www.xvideos.com/account/uploads>.

192. The Accused Systems provide commands that use protocols established by an API to select multimedia data from an indexing server satisfying one or more criteria specified by a browser, wherein the indexing server is associated with a catalogue.

193. These commands may include those commands issued to identify and display multimedia data that is responsive to the one or more keywords specified by the end-user as a query to search for adult videos, clips, and other types of media. The indexing server searches for multimedia data in the catalogue for those adult videos, clips, and other types of media in order to select those entries in the catalogue that are responsive to the end-user's query.

194. For example, adult videos, clips, and other types of media associated with the keyword “sex” are returned when this keyword is specified in the text interface and processed by the indexing server.

195. Moreover, adult videos, clips, and other types of media associated with the keywords “boobs”, “Jenna Jameson” and “Tera Patrick” are returned when these respective queries are provided in the search facility made available to end-users.

196. The Accused Systems associate multimedia data with a multimedia catalogue. The catalogue is maintained by an indexing server and is comprised of one or more data structures used to support searches for content that contains information concerning the content of multimedia data. See screenshots below. The catalog is the data structures containing records of information about adult videos, clips, and other types of media. These records are catalog elements. As shown below, the catalogue elements have information, such as keywords, identifying associated multimedia data. Examples of keywords include the title, from, categories, production, tags, date added, date featured of a given adult video, clip or other type of media.

197. End users can specify requests, i.e., input keywords, using the text interfaces. The indexing server processes the specified request by searching the catalogue (for example, using keywords) for multimedia data that satisfies the specified request.

198. The indexing server of the Accused System and Method uses a catalogue comprising a plurality of catalog elements associated with a plurality of keywords of the catalogue. For example, the data structure or database that holds the descriptive information shown below concerning each video, is a catalogue. Some examples of screenshots of webpages evidencing the catalogue elements and its attributes (person, category, keyword etc) as referenced below can be found at:

https://www.xvideos.com/pornstar-channels/elsa_jean#_tabAboutMe

https://www.xvideos.com/video7592747/sexy_blonde_stunning_naughty_babe

The above screenshots also illustrate segments pertaining to list of related videos ; cached prior search results and the use of a command interface API.

199. Catalog elements pertaining to such as adult videos, clips, and other types of media are associated with one or more keywords. Examples of keywords include among other things tags of a given adult video, clip or other type of media.

200. The catalogue is associated additional system components including, but not limited to, a text interface. The browsers of the Accused System are coupled to text interfaces. These text interfaces comprise at least one class of methods configured to specify a request for multimedia data. The text interface is a generalized interface for text commands that establish a protocol that can be used or adopted by a browser and/or an indexing server of different vendors to enable those multimedia components to communicate. The text interface is configured to specify a request for multimedia data (e.g., a search request based upon end-user supplied keywords).

201. The computer code for browsing the multimedia data includes code specifying a text interface for transmitting textual commands. Using the text interface, end users are able to specify a request for multimedia data and send the request to the indexing server.



202. Input from the text interface is submitted to the browser via client-side code.

```
<form action="/" id="xv-search-form" class="mobile-hide">
  <div>
```

```
<input type="text" name="k" value="" class="search-input" maxlength="2048">
<input type="submit" value="Search" class="search-submit">
</div>
</form>
```

203. The text interfaces of the Accused System are also coupled to an indexing server. The indexing server manages a catalogue of multimedia data.

204. The catalogue is maintained by an indexing server and is comprised of one or more data structures used to support searches for content that contains information concerning the content of multimedia data. See screenshots above. The catalog is the data structures containing records of information about adult videos, clips, and other types of media. These records are catalog elements. As shown below, the catalogue elements have information, such as keywords, identifying associated multimedia data. Examples of keywords include the title, from, categories, production, tags, date added, date featured of a given adult video, clip or other type of media.

205. End users can specify requests, i.e., input keywords, using the text interfaces. The indexing server processes the specified request by searching the catalogue (for example, using keywords) for multimedia data that satisfies the specified request.

206. For example, adult videos, clips, and other types of media associated with the keyword "sex" are returned when this keyword is specified in the text interface and processed by the indexing server.

207. Upon information and belief, Defendants exercise control over the devices of customers and third parties. Defendants' customers and third parties download Defendants' software and/or mobile applications to their devices and Defendants exercises control over those devices by sending computerized instructions, providing infringing software, providing user and other interfaces, and providing protocols to allow its customers and third parties to interact with

Defendants' servers and to use Defendants' systems and that of third parties in an infringing manner. Defendants control and put into use the interactions between customer and third-party devices and Defendants systems in an infringing manner in this jurisdiction and elsewhere.

208. Upon information and belief, Defendants' employees, in this Judicial District and elsewhere, operate the Accused Websites in an infringing manner, such as by way of example only (1) using the Accused Websites to support websites and applications; (2) putting into use by others (3) demonstrating the Accused System, (4) testing the Accused System, and (5) using the Accused Systems to catalogue multimedia.

209. Defendants also have agreements with users, content providers, customers, CDNs and other third parties that provide the requisite relationship, agency and control for joint infringement. Defendants and third parties engaged in the above activity expect, instruct, aid and abet, intend, know and derive economic and other benefit from the infringement's described above and below.

210. All of the above acts constitute acts of direct and joint infringement.

Induced and Contributory Infringement

211. Preservation restates and realleges each of the allegations set forth above and incorporates them herein.

212. Upon information and belief, Defendants' acts described as acts of direct infringement concerning the manufacture, use, putting into use, offering for sale, sale, operation, distribution, and/or installation of Defendants systems and/or software and those described above and below also constitute acts of induced and contributory infringement.

213. Upon information and belief, Defendants induce the direct infringement of the other Defendants and/or end users of the Defendants and/or third party CDNs that operate the infringing websites by providing corporate instruction, direction, capital, technical knowhow or expertise,

content, domain names, trademarks, advertising, legal defense, capital, and advertising sales that facilitate the operation of the Accused Websites in conducting infringing activity. All of the above are performed with knowledge of and with the specific intent to infringe the patents in suit.

214. Upon information and belief, third parties including Defendants' customers, users, CDNs, storage facilities, content providers and owners within this jurisdiction and elsewhere directly infringe the Asserted Patents and Defendants induce and/or contribute to that infringement. As an example only, end users of Defendants' Accused Websites, including, but not limited to Defendants' XVideos website, retrieve adult videos, clips, and other multimedia types by using (and putting into use) the systems and solutions claimed by the Asserted Patents. Further, users upload multimedia to Defendants' system and catalogue the uploaded multimedia in an infringing manner. Both the software made available at Defendants' websites and instructions provided by Defendants induce users and third parties to use an infringing system and method, and the third parties do in fact infringe.

215. Defendants induce users and third parties to infringe by providing monetary and/or other compensation, such as for uploading and cataloguing multimedia.

216. To the extent that some elements of a claim are performed by or owned by a different party than Defendants, Defendants, through software and infringing systems, put the claimed system of the Asserted Patents into service or use as described herein and receive a benefit upon performance of steps of the methods of the Asserted Patents. To the extent multimedia is provided by third-party servers or networks, Defendants' systems and/or Defendants' customers' systems put these third-party systems into use. For example, Defendants provide software instructions downloaded by third parties that put into use the third parties' players, CDNs and other systems. Third parties put into use Defendants' systems by indexing, searching for and retrieving

multimedia in an infringing manner and vice versa. Further, Defendants' software establishes the manner and/or timing of the performance of steps of the Asserted Patents, such as establishing the manner and/or timing of user's cataloguing, searching or playback of multimedia.

217. Upon information and belief, Defendants receive a benefit from such actions by the third parties as it allows Defendants to provide a desirable product or allows the third parties to purchase products and services from Defendant.

218. Upon information and belief, Defendants provide customers and/or other third parties instructions, materials, advertisements, services, encouragement, and software to use, load, and/or operate the Accused Systems in an infringing manner. Sending computerized instructions are acts of control by Defendants on the players of third parties. Upon information and belief, Defendants further induce customers and third parties to use the Accused Systems by providing subscriptions for the Accused Systems. Defendants have actively induced infringement by customers and/or third parties in this jurisdiction.

219. Upon information and belief, Defendants have acted with the specific intent to induce or cause infringement and to conduct acts of infringement as described herein within this jurisdiction and elsewhere. Defendants continue to provide instructions to customers and third parties to operate the Accused Systems in an infringing manner since having notice and actual knowledge of the Asserted Patents. Defendants' notice and actual knowledge of the Asserted Patents are more fully set forth in paragraphs 228-230 below.

220. Upon information and belief, customers and users of the Accused Systems reside in this jurisdiction and conduct acts of infringement within this jurisdiction. Upon information and belief, Defendants have and continue to indirectly infringe the Asserted Patents within this jurisdiction and elsewhere in the United States by, among other things, inducing and/or

contributing to third parties' infringement of the claims of the Asserted Patents without Plaintiff's authority.

221. Upon information and belief, Defendants provide, make, sell, and offer their Accused Systems with the specific intention that customers and/or other third-party direct infringers use the Accused Systems in an infringing manner. Upon information and belief, Defendants provide and instruct third parties to use the Accused Systems in the manner claimed in the Asserted Patents.

222. Upon information and belief, the Accused Systems have no substantial non-infringing use and are especially made and/or adapted so as to infringe the Asserted Patents.

223. Upon information and belief, Defendants know their systems, articles and services are especially made or especially adapted for use in an infringement of the Asserted Patents and are not a staple article or commodity of commerce suitable for substantial non-infringing use.

224. Each Defendant acquired knowledge of the Asserted Patents no later than June 1, 2016, the date the Defendants received Plaintiff's Notice of Infringement letter. *See Exhibit 8.* Upon information and belief, Defendants have had actual and constructive notice of Plaintiff's rights in the Asserted Patents since at least June 1, 2016.

225. On July 14, 2016, counsel for Defendants, Mr. Robert Seifert, responded to Preservation's Notice of Infringement letter. The response was non-substantive other than asserting an extraterritorial location of Defendants' servers. *See Exhibit 9.*

226. No later than June 2016, Defendants obtained knowledge that their actions constituted direct infringement of the Asserted Patents, induced infringement of the Asserted Patents and/or contributed to infringement of the Asserted Patents.

227. Notwithstanding, Defendants continue to willfully and with specific intent infringe upon and cause others to infringe upon one or more claims of the Asserted Patents.

VIII. ASSERTED CLAIMS

228. Plaintiff alleges infringement of the following patents and gives notice of least the following claims as being infringed⁴⁸:

Patent	Claims
'014	15-20, 22, 23, 24, 25
'499	3-7, 18
'080	2-4
'831	2
'495	14, 15
'537	8, 34, 35, 38, 45, 74
'060	13, 17
'527	15, 17
'911	14-16
'071	16
'638	22

The following claims are not independently asserted against Defendants:

Patent	Claims
'014	
'499	1, 2, 8, 9, 10, 11, 12,
'080	1, 7, 8, 9, 10, 11, 12, 13, 14-16
'831	1

⁴⁸ Although other claims are discussed above for purpose of explaining how claims of the patents reflect patent eligible concepts, Plaintiff's assertion of specific claims as being infringed in this Complaint is governed by this section.

'495	25, 27
'537	1
'060	1, 2, 3, 10, 11, 15
'527	1-5, 6, 7, 8, 9, 14
'911	25-30
'071	1
'638	1, 2, 3, 10, 11, 12, 13, 18, 19, 20, 21

229. With respect to the claims not identified above, Plaintiff further avers not all claims of all the patents in suit are infringed or will be asserted in this litigation or be in controversy. Most of the claims of the patents in suit are directed to back-end computer systems and that the source code and complete operation of the accused systems is not publicly available to fully assess all issues of infringement and invalidity. With respect to the claims not identified above, Plaintiff anticipates that this group of claims will be limited to a specific number by claim election at the appropriate Court scheduled time after appropriate discovery of source code with respect to infringement and disclosure of Defendants' invalidity defenses.

COUNT 1

(Direct and indirect infringement of United States Patent No. 5,813,014)

230. Preservation restates and realleges each of the allegations set forth above and incorporates them herein.

231. Defendants, without permission of Preservation, have been and are presently infringing the '014 Patent, as infringement is defined by 35 U.S.C. § 271(a), by making, using, putting into use, offering to sell, and selling the Accused Systems and those of third parties including without limitation customers and CDNs. By way of example only, Defendants' Accused Websites such as xvideos.com directly infringe claim 21 as follows:

21. An article of manufacture comprising:

a computer usable medium having computer readable program code embodied therein for accessing multimedia data, the computer readable program code in said article of manufacture comprising:

Defendants' Accused Websites are stored and operated on computer systems having computer readable media having code for accessing multimedia data. Multimedia data may be accessed by clicking on links provided on the Accused Website or searching for multimedia using Defendants' search feature.

computer readable program code configured to cause a computer to define a catalogue for said multimedia data having a plurality of catalogue elements each of which is associated with a portion of said multimedia data, said plurality of catalogue elements associated with a plurality of keywords of said catalogue, said plurality of keywords identifying said multimedia data, said plurality of keywords being interrelated by one or more of associative, whole-part and inheritance relationships;

Defendants' Accused Websites catalogue multimedia data by associating portions of multimedia data with a plurality of keywords. Defendants' Websites associate clips, and other types of media with one or more keywords. Examples of keywords include tags and category listings. For example, multimedia associated with the keywords "amateur" are returned when this keyword is queried. Upon information and belief, at least one of the data structures containing the title, id, and other descriptive information (some of which is displayed with the link to the video) and tags associated with the multimedia portion may meet this limitation. There are also child-parent relationships between the catalogue elements and between keywords described above.

computer readable program code configured to cause a computer to specify a search request;

Defendants' Accused Websites allow its users to specify search requests.

computer readable program code configured to cause a computer to identify a result of said search request that satisfies said search request, said result containing one or more of said plurality of catalogue elements;

The Accused Websites identifies multimedia responsive to the search request.

computer readable program code configured to cause a computer to retrieve said portion of said multimedia data associated with said one or more of said plurality of catalogue elements;

The Accused Websites retrieves multimedia responsive to the search request and presents them to the user.

computer readable program code configured to cause a computer to store in said catalogue said search request; and computer readable program code configured to cause a computer to store in said catalogue said search result.

Among other things, Defendants' Accused Websites store its users' search requests and results, such as for data analytics or to fulfill related searches or repeat prior searches. Example is shown at: https://www.xvideos.com/video7592747/sexy_blonde_stunning_naughty_babe

Thus, Defendants use the invention covered by at least one claim of the '014 Patent. The above description is not intended to comprehensively show how Defendants' Accused Websites infringe the Patents-in-Suit in all cases for all software and/or hardware. Not all infringing features of the Accused Websites are addressed, nor are all infringing features of the Accused Websites mapped to elements of the claims. However, each claim limitation is mapped to at least one infringing feature, Plaintiff reserves the right to rely other features of Defendants' Websites to meet the same limitations of the Patents-in-Suit, or the above-described features of the Accused Websites to meet other limitations of the Patents-in-Suit. The descriptions are only meant as exemplary evidence to assist Defendants' in identifying Accused Software and to show how Defendants' Websites plausibly infringe one claim of each of the Patents-in-Suit in one specific instance.

232. Defendants indirectly infringe the '014 Patent by inducing or contributing to the infringement of the '014 Patent, including but not limited to infringement by customers/consumers, in violation of 35 U.S.C. § 271(b)-(c)&(f). To the extent that Defendants are not directly liable for infringement of the '014 Patent, they collectively and individually induce the operators of the Accused Websites to infringe the '014 Patent.

233. Defendants do not have a license or permission to use the claimed subject matter of the '014 Patent.

234. As a direct and proximate result of Defendants' direct, joint, induced, and/or contributory infringement of the '014 Patent, Preservation has been injured and has been caused significant financial damage.

235. Preservation alleges upon information and belief that Defendants have, knowingly or with willful blindness, willfully infringed one or more claims of the '014 patent. Defendants had knowledge of the Asserted Patents as set forth above, having been advised of the existence and substance of the Asserted Patents by Preservation. Defendants acted with knowledge of the Asserted Patents, and, despite knowledge or despite the facts that they should have known of an objectively high likelihood that their actions constituted infringement of Preservation's valid patent rights, continue to infringe.

236. This objectively defined risk was either known or so obvious that it should have been known to Defendants. Preservation seeks enhanced damages pursuant to 35 U.S.C. § 284 from Defendants.

237. As a result of Defendants' infringement of the '014 Patent, Preservation has suffered monetary damages. Defendants are thus liable to Preservation in an amount that

adequately compensates it for Defendants' infringement, which, by law, cannot be less than a reasonable royalty, together with interest and costs as fixed by this Court under 35 U.S.C. § 284.

COUNT 2

(Direct and indirect infringement of United States Patent No. 5,832,499)

238. Preservation restates and realleges each of the allegations set forth above and incorporates them herein.

239. Defendants, without permission of Preservation, have been and are presently infringing the '499 Patent, as infringement is defined by 35 U.S.C. § 271(a), by making, using, offering to sell, and selling the Accused Systems and those of third parties including without limitation customers and CDNs

240. By way of example only, Defendants' Accused Websites such as xvideos.com directly infringe claim 16 as follows:

16. An article of manufacture comprising: a computer usable medium having computer readable program code embodied therein for retrieving data in a digital library system, the computer readable program code in said article of manufacture comprising:
Defendants' Accused Websites are stored and operated on computer systems having computer readable media having code for retrieving data from a digital library system. Multimedia from the digital library system is retrieved by clicking on links provided on the Accused Website or searching for multimedia using Defendants' search feature.

computer readable program code configured to cause a computer to search a local cache for a portion of multimedia data stored in said digital library system, said digital library system having a catalogue of said multimedia data comprising at least one catalogue element associated with a plurality of keywords of said catalogue, said plurality of keywords identifying said portion of said multimedia data, said plurality of keywords

being interrelated by one or more of associative, whole-part and inheritance relationships;

Defendants' Accused Websites catalogue multimedia data by associating portions of multimedia data with a plurality of keywords. Defendants' Websites associate adult videos, clips, and other types of media with one or more keywords. At least one of the data structures containing descriptive information and tags associated with the multimedia portion may meet this limitation. There are also child-parent relationships between the catalogue elements described above. Keywords have child parent relationships with each other. Examples of keywords include categories and tags. For example, multimedia associated with the keyword "amateur" are returned when this keyword is queried.

Defendants' Accused Websites uses protocols that retrieves multimedia data from caches provided by Defendants' CDN.

computer readable program code configured to cause a computer to retrieve said portion of multimedia data into said local cache from a remote cache, if said portion of multimedia data is resident in said remote cache and is not found in said local cache; computer readable program code configured to cause a computer to retrieve said portion of multimedia data into said local cache from permanent storage, if said portion of

```
</div><object type="application/x-shockwave-flash" data=  
"http://cdn1b.static.pornhub.phncdn.com/www-static/flash/player2013.swf?cache=2014052902"  
width="100%" height="100%" id="playerDiv_1086045" style="visibility: visible;">
```

multimedia data is resident on permanent storage and is not found in said local cache or said remote cache.

Upon information and belief, Defendants and third party CDNs employ multiple caches and other memory and/or storage and prioritize certain caches for storage and retrieval based on various factors.

241. The above description is not intended to comprehensively show how Defendants' Accused Websites infringe the Patents-in-Suit in all cases for all software and/or hardware. Not all infringing features of the Accused Websites are addressed, nor are all infringing features of the Accused Websites mapped to elements of the claims. However, each claim limitation is mapped to at least one infringing feature, Plaintiff reserves the right to rely other features of Defendants' Websites to meet the same limitations of the Patents-in-Suit, or the above-described features of the Accused Websites to meet other limitations of the Patents-in-Suit. The descriptions are only meant as exemplary evidence to assist Defendants' in identifying Accused Software and to show how Defendants' Websites plausibly infringe one claim of each of the Patents-in-Suit in one specific instance.

242. Defendants indirectly infringe the '499 Patent by inducing or contributing to the infringement of the '499 Patent, including but not limited to infringement by their customers/consumers, in violation of 35 U.S.C. § 271(b)-(c)&(f). To the extent that Defendants are not directly liable for infringement of the '499 Patent, they collectively and individually induce the operators of the Accused Websites to infringe the '499 Patent.

243. Defendants do not have a license or permission to use the claimed subject matter of the '499 Patent.

244. As a direct and proximate result of Defendants' direct, joint, induced, and/or contributory infringement of the '499 Patent, Preservation has been injured and has been caused significant financial damage.

245. Preservation alleges upon information and belief that Defendants have, knowingly or with willful blindness, willfully infringed one or more claims of the '499 patent. Defendants had knowledge of the Asserted Patents as set forth above, having been advised of the existence

and substance of the Asserted Patents by Preservation. Defendants acted with knowledge of the Asserted Patents, and, despite their knowledge or despite that they should have known of an objectively high likelihood that their actions constituted infringement of Preservation's valid patent rights, continue to infringe.

246. This objectively defined risk was either known or so obvious that it should have been known to Defendants. Preservation seeks enhanced damages pursuant to 35 U.S.C. § 284 from Defendants.

247. As a result of Defendants' infringement of the '499 Patent, Preservation has suffered monetary damages. Defendants are thus liable to Preservation in an amount that adequately compensates it for Defendants' infringement, which, by law, cannot be less than a reasonable royalty, together with interest and costs as fixed by this Court under 35 U.S.C. § 284.

COUNT 3

(Direct and indirect infringement of United States Patent No. 6,092,080)

248. Preservation restates and realleges each of the allegations set forth above and incorporates them herein.

249. Defendants, without permission of Preservation, have been and are presently infringing the '080 Patent, as infringement is defined by 35 U.S.C. § 271(a), by making, using, offering to sell, and selling the Accused Systems and those of third parties including without limitation customers and CDNs.

250. By way of example only, Defendants' Accused Websites such as xvideos.com directly infringe claim 2 as follows:

1. A digital library system comprising: a cataloguing system having a catalogue of multimedia data comprising at least one catalogue element associated with a plurality of keywords identifying said multimedia data;

Defendants' Accused Websites are a digital library system that catalogues multimedia data. At least one of the data structures containing descriptive information (title, tags, etc.) associated with a video meets part of this limitation. There are also child-parent relationships between the catalogue elements described above. Keywords have child parent relationships with each other.

an access management system coupled to said cataloguing system; and

Defendants' Websites includes an access management system. For example, Defendants' websites provide access through a variety of devices and browsers such as tablets and mobile devices such as iOS and Android powered devices that are operatively connected to index servers, API interfaces and other multimedia components.

a distribution system coupled to said access management system.

Defendants, through their own or third party CDNs, provide a distribution system that distributes multimedia data so the data may be accessed on its users' devices.

2. The digital library system of claim 1 wherein said access management system further comprises: a browser; a text interface coupled to said browser;

Defendants' websites provide a browser and a there is a text box operatively coupled to a text based API that may query an index server.

an indexing server coupled to said text interface;

There is a text box operatively coupled to a text based API that may query an index server.

```
<form action="/" id="xv-search-form" class="mobile-hide">
  <div>
    <input type="text" name="k" value="" class="search-input" maxlength="2048">

```

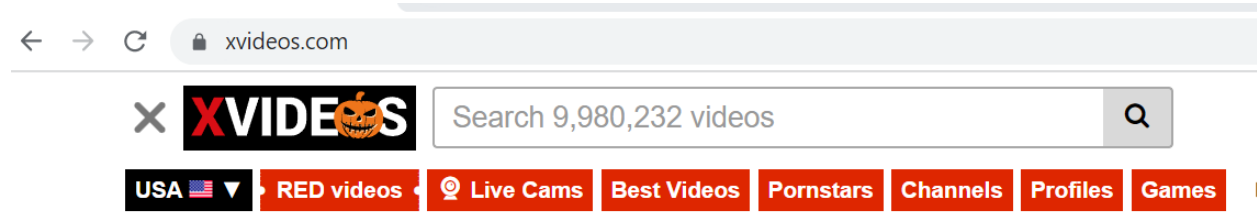

```

    <input type="submit" value="Search" class="search-submit">
  </div>
</form>
```

a first media interface coupled to said browser an archive server coupled to said media interface

251. Preservation asserts that this element is present in the Accused System and Method literally and/or under the doctrine of equivalents.

The browsers of the Accused System and Method are operatively coupled to a media interface. As depicted below, Defendant's systems include software for selecting multimedia data and transmitting an identifier associated with that multimedia data.

The first media interface is a generalized interface for media commands that establish a protocol that can be used or adopted by a browser and/or an archive server of different vendors to enable those multimedia components to communication. The generalized interface is configured to transmit the identifiers of requested multimedia data.

Each multimedia data file (e.g., adult videos, clips, and other types of media) within XVideos's multimedia system is assigned a unique ID. For example, the ID of the video "HD - FantasyHD Busty Corrine Blake gets rub down on pierced" is identified by the identifier 9520567.

[Http://www.xvideos.com/video9520567/hd_-_fantasyhd_busty_corrine_blake_gets_rub_down_on_pierced_....](http://www.xvideos.com/video9520567/hd_-_fantasyhd_busty_corrine_blake_gets_rub_down_on_pierced_....)".

The Accused System and Method contains a software interface (i.e., the first media interface) comprising a configuration especially adapted for media commands according to a generalized communications protocol that transmits identifiers (IDs) specifying particular multimedia data requested by the user through the browser. Use of an ID can be clearly seen here, where the Accused System and Method uses the identifier 9520567 to identify the video "HD - FantasyHD Busty Corrine Blake gets rub down on pierced".

```
<script type="text/javascript">
  logged_user = false;
  var html5player = new HTML5Player('html5video', '9520567');
  html5player.setVideoTitle('HD - FantasyHD Busty Corrine Blake gets rub down on
  pierce...d');

  html5player.setSponsors([[{"link":"http://join.fantasyhd.com/track/MTMxOjU3OjE0MA,1
  9/", "desc":"FantasyHD offers the Highest Quality available and presents inventive
  sexual scenarios, role-play and adventures. You will find the sexiest girls bringing
  your hottest fantasy to reality.",
  "records2257":"http://fantasyhd.com/2257", "name":"Fantasy HD"}]]);

  html5player.setVideoUrlLow('http://porn.im.457f1800.9520567.x.xvideos.com/videos/
  3gp/7/d/a/xvideos.com_7dacc2b4d71fb300dd948a3026061b3.mp4?
  e=1470697614&ri=1024&rs=85&h=5b0b807f4364504c8395a15206129a6e');

  html5player.setVideoUrlHigh('http://porn.im.457f1800.9520567.x.xvideos.com/videos/
  mp4/7/d/a/xvideos.com_7dacc2b4d71fb300dd948a3026061b3.mp4?
  e=1470697614&ri=1024&rs=85&h=9131e4b584d59c593f46d0e7e9405e5b');
```

```

    html5player.setVideoHLS('http://cdn4-13-
cdn.xvideos.com/c0afb3a6e368479dc3d5c0f3fdc8adb135511f86-
1470697614/videos/hls/7d/ac/cc/7dacc2b4d71fb300dd948a3026061b3/hls.m3u8');
    html5player.setThumbUrl('http://img-13.xvideos.com/videos/thumbs111/
7d/ac/cc/7dacc2b4d71fb300dd948a3026061b3/ 7dacc2b4d71fb300dd948a3026061b3.2.jpg');
    html5player.setRelated(video_related);
    html5player.setThumbSlide('http://img-
13.xvideos.com/videos/thumbs/7d/ac/cc/7dacc2b4d71fb300dd948a3026061b3/mozaique.jpg');
    html5player.setIdCDN('1');
    html5player.setIdCdnHLS('3');
    html5player.setFakePlayer(false);
    html5player.setDesktopview(true);
    html5player.setVideoURL('/video9520567/hd_-
_fantasyhd_busty_corrine_blake_gets_rub_down_on_pierced_clit');
    html5player.initPlayer();
  </script>

```

Defendants' websites and CDN's provide an archive server interfaced with the browser for providing storage location information at defendant's website and/or CDNs. It retrieves multimedia data for a video identified by its id using the interface. An example is the use of Highwinds Network Group to serve videos.

This is a software limitation and the software of the Accused System is not publicly available. Plaintiff reserves the right to supplement these infringement contentions.

a second media interface coupled to said browser; and a method player coupled to said second media interface.

Defendants' websites provide has a media interface and protocol for transmitting the multimedia data to be rendered within the browser window and played by the method player. This interface includes a protocol that (1) loads the video. (2) instructs and controls playback of the video and (3) instructs the player as to the settings with respect to the location and size within the browser to render the video.

Defendants thus uses the invention covered by at least one claim of the '080 Patent. The above description is not intended to comprehensively show how Defendants' Accused Websites infringe the Patents-in-Suit in all cases for all software and/or hardware. Not all infringing features of the Accused Websites are addressed, nor are all infringing features of the Accused Websites mapped to elements of the claims. However, each claim limitation is mapped to at least one infringing feature, Plaintiff reserves the right to rely other features of Defendants' Websites to meet the same limitations of the Patents-in-Suit, or the above described features of the

Accused Websites to meet other limitations of the Patents-in-Suit. The descriptions are only meant as exemplary evidence to assist Defendants' in identifying Accused Software and to show how Defendants' Websites plausibly infringe one claim of each of the Patents-in-Suit in one specific instance.

252. Defendants indirectly infringe the '080 Patent by inducing or contributing to the infringement of the '080 Patent, including but not limited to infringement by their customers/consumers, in violation of 35 U.S.C. § 271(b)-(c)&(f). To the extent that Defendants are not directly liable for infringement of the '080 Patent, they collectively and individually induce the operators of the Accused Websites to infringe the '080 Patent.

253. Defendants do not have a license or permission to use the claimed subject matter of the '080 Patent.

254. As a direct and proximate result of Defendants' direct, joint, induced, and/or contributory infringement of the '080 Patent, Preservation has been injured and has been caused significant financial damage.

255. Preservation alleges upon information and belief that Defendants have, knowingly or with willful blindness, willfully infringed one or more claims of the '080 patent. Defendants had knowledge of the Asserted Patents as set forth above, having been advised of the existence and substance of the Asserted Patents by Preservation. Defendants acted with knowledge of the Asserted Patents, and, despite their knowledge or despite that they should have known of an objectively high likelihood that their actions constituted infringement of Preservation's valid patent rights, continue to infringe.

256. This objectively defined risk was either known or so obvious that it should have been known to Defendants. Preservation seeks enhanced damages pursuant to 35 U.S.C. § 284 from Defendants.

257. As a result of Defendants' infringement of the '080 Patent, Preservation has suffered monetary damages. Defendants are thus liable to Preservation in an amount that adequately compensates it for Defendants' infringement, which, by law, cannot be less than a reasonable royalty, together with interest and costs as fixed by this Court under 35 U.S.C. § 284.

COUNT 4

(Direct and indirect infringement of United States Patent No. 6,353,831)

258. Preservation restates and realleges each of the allegations set forth above and incorporates them herein.

259. Defendants, without permission of Preservation, have been and are presently infringing the '831 Patent, as infringement is defined by 35 U.S.C. § 271(a), by making, using, offering to sell, and selling the Accused Systems and those of third parties including without limitation customers and CDNs. By way of example only, Defendants' Accused Websites such as xvideos.com directly infringe claim 6 as follows:

1. A digital library system comprising: a means for cataloguing multimedia data using at least one catalogue element associated with a plurality of keywords identifying said multimedia data;

Defendants' Accused Websites are a digital library system that catalogues multimedia using keyword associations. At least one of the data structure containing descriptive information and tags associated with the multimedia portion, among other things, may meet this limitation. There are also child-parent relationships between the catalogue elements described above.

a means for managing access to said cataloguing system; and

Defendants' Websites includes an access management system that provides different interfaces based upon the type of audience. For example, Defendants' websites provide access through a variety of devices and browsers such as tablets and mobile devices such as iOS and Android powered devices.

a means for distributing said multimedia data.

Defendants, through their own or third party CDNs, provide a distribution system that distributes multimedia data so the data may be accessed on its users devices.

6. The system of claim 1 wherein said distributing said multimedia further comprises: a means for permanently storing said multimedia data in said digital library system at a main site; a means for temporarily storing some or all of said multimedia data in said digital library system at a plurality of remote sites.

Upon information and belief, Defendants and third party CDNs employ multiple caches and other memory and/or storage at different sites and prioritize certain caches for storage and retrieval based on various factors.

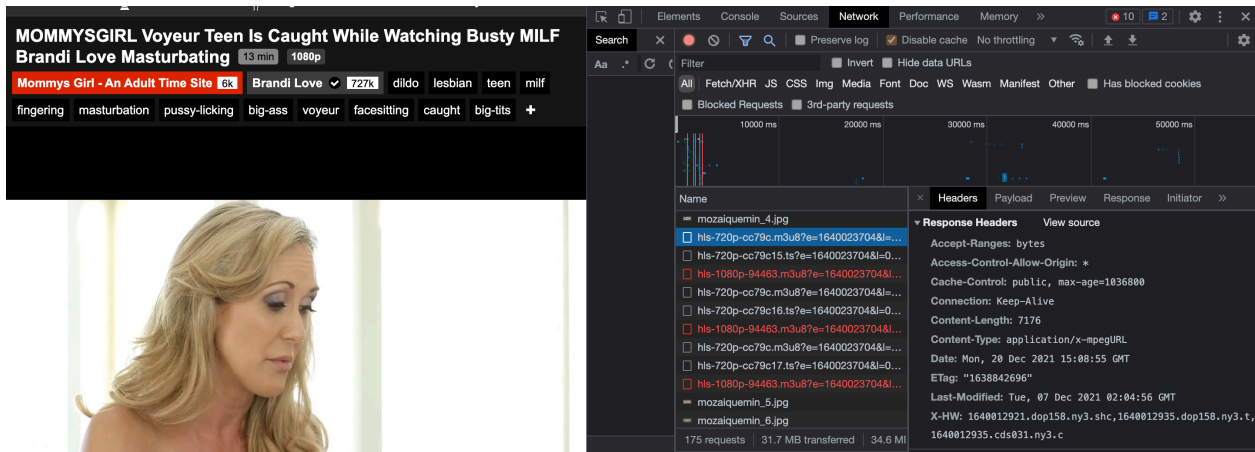

Source:

https://www.xvideos.com/video66936583/mommysgirl_voyeur_teen_is_caught_while_watching_busty_milf_brandi_love_masturbating, showing “Cache-Control: public, max-age=1036800

260. Thus, Defendants use the invention covered by at least one claim of the ’831 Patent.

The above description is not intended to comprehensively show how Defendants’ Accused Websites infringe the Patents-in-Suit in all cases for all software and/or hardware. Not all infringing features of the Accused Websites are addressed, nor are all infringing features of the Accused Websites mapped to elements of the claims. However, each claim limitation is mapped

to at least one infringing feature, Plaintiff reserves the right to rely other features of Defendants' Websites to meet the same limitations of the Patents-in-Suit, or the above described features of the Accused Websites to meet other limitations of the Patents-in-Suit. The descriptions are only meant as exemplary evidence to assist Defendants' in identifying Accused Software and to show how Defendants' Websites plausibly infringe one claim of each of the Patents-in-Suit in one specific instance.

261. Defendants indirectly infringe the '831 Patent by inducing or contributing to the infringement of the '831 Patent, including but not limited to infringement by their customers/consumers, in violation of 35 U.S.C. § 271(b)-(c)&(f). To the extent that Defendants are not directly liable for infringement of the '831 Patent, they collectively and individually induce the operators of the Accused Websites to infringe the '831 Patent.

262. Defendants do not have a license or permission to use the claimed subject matter of the '831 Patent.

263. As a direct and proximate result of Defendants' direct, joint, induced, and/or contributory infringement of the '831 Patent, Preservation has been injured and has been caused significant financial damage.

264. Preservation alleges upon information and belief that Defendants have, knowingly or with willful blindness, willfully infringed one or more claims of the '831 patent. Defendants had knowledge of the Asserted Patents as set forth above, having been advised of the existence and substance of the Asserted Patents by Preservation. Defendants acted with knowledge of the Asserted Patents, and, despite their knowledge or despite that they should have known of an objectively high likelihood that their actions constituted infringement of Preservation's valid patent rights, continue to infringe.

265. This objectively defined risk was either known or so obvious that it should have been known to Defendants. Preservation seeks enhanced damages pursuant to 35 U.S.C. § 284 from Defendants.

266. As a result of Defendants' infringement of the '831 Patent, Preservation has suffered monetary damages. Defendants are thus liable to Preservation in an amount that adequately compensates it for Defendants' infringement, which, by law, cannot be less than a reasonable royalty, together with interest and costs as fixed by this Court under 35 U.S.C. § 284.

COUNT 5

(Direct and indirect infringement of United States Patent No. 5,832,495)

267. Preservation restates and realleges each of the allegations set forth above and incorporates them herein.

268. Defendants, without permission of Preservation, have been and are presently infringing the '495 Patent, as infringement is defined by 35 U.S.C. § 271(a), by making, using, offering to sell, and selling the Accused Systems and those of third parties including without limitation customers and CDNs. By way of example only, Defendants' Accused Websites such as xvideos.com directly infringe claim 13 as follows:

13. An article of manufacture comprising: a computer usable medium having computer readable program code embodied therein for cataloguing multimedia data using a general indexing structure, the computer readable program code in said article of manufacture comprising; computer readable program code configured to cause a computer to create a catalogue comprising a plurality of elements and relationships between said plurality of elements, said plurality of elements identifying data associated with said multimedia data, said data including keywords interrelated via one or more

associative, whole-part and inheritance relationships, and other multimedia data associated with said multimedia data;

Defendants' Accused Websites are a computer system embodied on a computer readable medium having code for cataloguing multimedia data using a general indexing structure. At least one of the data structures containing descriptive information and tags associated with the multimedia portion, among other things, may meet this limitation. The catalogue includes software that manages relationships between multimedia and keywords, including assigning relationships and modifying relationships.

computer readable program code configured to cause a computer to specify a description for a portion of said multimedia data;

The Accused Websites include descriptions such as tags for portions of multimedia data.

<https://www.xvideos.com/tags>.

computer readable program code configured to cause a computer to create a catalogue element in said catalogue, said catalogue element containing a pointer to said portion of said multimedia data; and

XVIDEOS FREQUENTLY ASKED QUESTIONS 

Search for... **Search**

[Go back to FAQ home](#)

How can I edit a video?

You can see all your [uploaded](#) videos under "My Content" tab in your [account area](#). Here you can edit video to change its category, title, description, tags and translations.

Section: [Uploaders](#), [Manage content](#)

MORE QUESTIONS? EMAIL US

https://info.xvideos.com/faq/question/37-uploaders-how_can_i_edit_a_video

At least one of the data structures containing descriptive information and tags associated with the multimedia portion, among other things, may meet this limitation. There are also child-parent relationships between the catalogue elements and also between the keywords described above.

computer readable program code configured to cause a computer to create for said catalogue element a pointer to at least one of said keywords, said at least one of said keywords containing a plurality of pointers to a set of elements in said catalogue interrelated to said at least one of said keywords via said one or more associative, whole-part and inheritance relationships, and creating for said catalogue element a plurality of pointers to elements in said catalogue that identify other multimedia data associated with said portion of multimedia data.

Defendants' Accused Websites include pointers to portions of multimedia data associated with a catalogue element. For example, Defendants' Websites provide links associated with specific keywords that identify the portions of a related video. The link directs end users to the specific time within the video of the keyword. Defendants use the invention covered by at least one claim of the '495 Patent. The above description is not intended to comprehensively show how Defendants' Accused Websites infringe the Patents-in-Suit in all cases for all software and/or hardware. Not all infringing features of the Accused Websites are addressed, nor are all infringing features of the Accused Websites mapped to elements of the claims. However, each claim limitation is mapped to at least one infringing feature, Plaintiff reserves the right to rely other features of Defendants' Websites to meet the same limitations of the Patents-in-Suit, or the above described features of the Accused Websites to meet other limitations of the Patents-in-Suit. The descriptions are only meant as exemplary evidence to assist Defendants' in identifying Accused Software and to show how Defendants' Websites plausibly infringe one claim of each of the Patents-in-Suit in one specific instance.

269. Defendants indirectly infringe the '495 Patent by inducing or contributing to the infringement of the '495 Patent, including but not limited to infringement by their customers/consumers, in violation of 35 U.S.C. § 271(b)-(c)&(f). To the extent that Defendants are not directly liable for infringement of the '495 Patent, they collectively and individually induce the operators of the Accused Websites to infringe the '495 Patent.

270. Defendants do not have a license or permission to use the claimed subject matter of the '495 Patent.

271. As a direct and proximate result of Defendants' direct, joint, induced, and/or contributory infringement of the '495 Patent, Preservation has been injured and has been caused significant financial damage.

272. Preservation alleges upon information and belief that Defendants have, knowingly or with willful blindness, willfully infringed one or more claims of the '495 patent. Defendants had knowledge of the Asserted Patents as set forth above, having been advised of the existence and substance of the Asserted Patents by Preservation. Defendants acted with knowledge of the Asserted Patents, and, despite their knowledge or despite that they should have known of an objectively high likelihood that their actions constituted infringement of Preservation's valid patent rights, continue to infringe.

273. This objectively defined risk was either known or so obvious that it should have been known to Defendants. Preservation seeks enhanced damages pursuant to 35 U.S.C. § 284 from Defendants.

274. As a result of Defendants' infringement of the '495 Patent, Preservation has suffered monetary damages. Defendants are thus liable to Preservation in an amount that adequately compensates it for Defendants' infringement, which, by law, cannot be less than a reasonable royalty, together with interest and costs as fixed by this Court under 35 U.S.C. § 284.

COUNT 6

(Direct and indirect infringement of United States Patent No. 6,477,537)

275. Preservation restates and realleges each of the allegations set forth above and incorporates them herein.

276. Defendants, without permission of Preservation, have been and are presently infringing the '537 Patent, as infringement is defined by 35 U.S.C. § 271(a), by making, using, offering to sell, and selling the Accused Systems and those of third parties including without limitation customers and CDNs. By way of example only, Defendants' Accused Websites such as xvideos.com directly infringe claim 2 as follows:

1. An application program interface (API) embodied on a computer readable medium for execution on a computer in conjunction with an application program to interface components in a multimedia system comprising: an API protocol means comprising a command interface between a first system component and at least one additional system component, said command interface comprising:

Defendants' Accused Websites include an API for execution on a computer in conjunction with an application program to interface components in a multimedia system. The API issues commands and communicates between the browser and other multimedia components. This system provides users with the ability to search for and access multimedia asserts using Internet-enabled devices including computers, tablets, and mobile devices.

means for selecting multimedia data that satisfies a criteria of said first system component selected using said API protocol means, said multimedia data associated with a multimedia catalogue, said catalogue associated with said at least one additional system component;

The command interface includes commands issued to identify and display multimedia data that is responsive to the one or more functions specified by the end-user as a API query for certain types of data for adult videos, clips, and other types of media. The API uses a generalized multimedia protocol. The indexing server searches for multimedia data in the catalogue for those adult videos, clips, and other types of media in order to select those entries in the catalogue that are responsive to the end-user's query.

277. The code, DML, protocols and operations supporting the above depicted meet the means for selecting limitation.

means for retrieving from said at least one additional system component multimedia data selected by said selecting means; means for displaying said multimedia data retrieved by said retrieving means.

The API command interface retrieves and displays multimedia data selected by the user in the manner specified in the claim (as well as location information). The accused functions may implicate segment elements and other information and routines involving prior searches, query analysis, lists of related videos.

16. The API protocol means of claim 1 wherein said multimedia data comprise a type catalogued in said indexing server.

Two components of Defendants' system that are being interfaced by the claim means are a browser and an indexing server. Thus, Defendants use the invention covered by at least one claim of the '537 Patent. The above description is not intended to comprehensively show how Defendants' Accused Websites infringe the Patents-in-Suit in all cases for all software and/or hardware. Not all infringing features of the Accused Websites are addressed, nor are all infringing features of the Accused Websites mapped to elements of the claims. However, each claim limitation is mapped to at least one infringing feature, Plaintiff reserves the right to rely other features of Defendants' Websites to meet the same limitations of the Patents-in-Suit, or the above-described features of the Accused Websites to meet other limitations of the Patents-in-Suit. The descriptions are only meant as exemplary evidence to assist Defendants' in identifying Accused Software and to show how Defendants' Websites plausibly infringe one claim of each of the Patents-in-Suit in one specific instance.

278. Defendants indirectly infringe the '537 Patent by inducing or contributing to the infringement of the '537 Patent, including but not limited to infringement by their customers/consumers, in violation of 35 U.S.C. § 271(b)-(c)&(f). To the extent that Defendants

are not directly liable for infringement of the '537 Patent, they collectively and individually induce the operators of the Accused Websites to infringe the '537 Patent.

279. Defendants do not have a license or permission to use the claimed subject matter of the '537 Patent.

280. As a direct and proximate result of Defendants' direct, joint, induced, and/or contributory infringement of the '537 Patent, Preservation has been injured and has been caused significant financial damage.

281. Preservation alleges upon information and belief that Defendants have, knowingly or with willful blindness, willfully infringed one or more claims of the '537 patent. Defendants had knowledge of the Asserted Patents as set forth above, having been advised of the existence and substance of the Asserted Patents by Preservation. Defendants acted with knowledge of the Asserted Patents, and, despite their knowledge or despite that they should have known of an objectively high likelihood that their actions constituted infringement of Preservation's valid patent rights, continue to infringe.

282. This objectively-defined risk was either known or so obvious that it should have been known to Defendant. Preservation seeks enhanced damages pursuant to 35 U.S.C. § 284 from Defendant.

283. As a result of Defendants' infringement of the '537 Patent, Preservation has suffered monetary damages. Defendants are thus liable to Preservation in an amount that adequately compensates it for Defendants' infringement, which, by law, cannot be less than a reasonable royalty, together with interest and costs as fixed by this Court under 35 U.S.C. § 284.

COUNT 7

(Direct and indirect infringement of United States Patent No. 6,199,060)

284. Preservation restates and realleges each of the allegations set forth above and incorporates them herein.

285. Defendants, without permission of Preservation, have been and are presently infringing the '060 Patent, as infringement is defined by 35 U.S.C. § 271(a), by making, using, offering to sell, and selling the Accused Systems and those of third parties including without limitation customers and CDNs. By way of example only, Defendants' Accused Websites such as xvideos.com directly infringe claim 16 as follows:

15. A computer program product comprising: a computer usable medium having computer readable program code embodied therein configured to interface components in a multimedia system comprising: computer readable program code configured to cause a computer to define a generalized protocol for interfacing components of a multimedia system, said generalized protocol comprising commands configured to access multimedia data, said multimedia data associated with a catalogue;

Defendants' Accused Websites are a computer program product on a computer readable medium having code defining a generalized protocol for interfacing multimedia components to access multimedia data associated with a catalogue. The generalized protocol is an API which specifies the interaction between software components of a multimedia system including a browser, index server, and method player and comprises commands configured to invoke a search request, return a search response, invoke a retrieval request, and invoke a transmit request to search for and retrieve multimedia from the multimedia system. End users of Defendants' system utilize the API when searching and retrieving multimedia:

computer readable program code configured to cause a computer to invoke a search request using said generalized protocol, said search request configured to initiate a search of said catalogue to identify multimedia data;

The end user is able to search for multimedia data such as or about videos and clips. The Accused System does so by invoking a search request using the generalized protocol to initiate a search of the catalogue. For example, a user initiates a routine of the API to retrieve the claimed data about multimedia:

computer readable program code configured to cause a computer to communicate between at least two of said components using said generalized protocol;

The Accused Website includes API protocols that communicate between the browser and the index server to display multimedia.

computer readable program code configured to cause a computer to return a search response using said generalized protocol, said search response identifying a plurality of catalogue elements; computer readable program code configured to cause a computer to invoke a retrieval request using said generalized protocol;

The Accused Websites include code to return search responses using the generalized protocol, such as in response to an end user query using an API routine. The Websites further include code and other information to retrieve multimedia data using the generalized protocol.

The code, protocols, DML and data structures supporting the above depicted function, among other things, meets this element.

computer readable program code configured to cause a computer to invoke a transmit request using said generalized protocol, said transmit request configured to transmit multimedia data identified by said at least one of said plurality of catalogue elements.

The Accused Websites include code to invoke a transmit request using the generalized protocol to transmit multimedia data identified by the search query to the end user so that a selected and retrieved video may ultimately be displayed in the browser window.

16. The computer program product of claim 15 wherein said retrieval request specifies at least one of said plurality of said catalogue elements.

The retrieval request specifies a particular video and potentially keywords and ids of a video.

286. Defendants use the invention covered by at least one claim of the '060 Patent. The above description is not intended to comprehensively show how Defendants' Accused Websites infringe the Patents-in-Suit in all cases for all software and/or hardware. Not all infringing features of the Accused Websites are addressed, nor are all infringing features of the Accused Websites mapped to elements of the claims. However, each claim limitation is mapped to at least one infringing feature, Plaintiff reserves the right to rely other features of Defendants' Websites to meet the same limitations of the Patents-in-Suit, or the above-described features of the Accused Websites to meet other limitations of the Patents-in-Suit. The descriptions are only meant as exemplary evidence to assist Defendants' in identifying Accused Software and to show how Defendants' Websites plausibly infringe one claim of each of the Patents-in-Suit in one specific instance.

287. Defendants indirectly infringe the '060 Patent by inducing or contributing to the infringement of the '060 Patent, including but not limited to infringement by their customers/consumers, in violation of 35 U.S.C. § 271(b)-(c)&(f). To the extent that Defendants are not directly liable for infringement of the '060 Patent, they collectively and individually induce the operators of the Accused Websites to infringe the '060 Patent.

288. Defendants do not have a license or permission to use the claimed subject matter of the '060 Patent.

289. As a direct and proximate result of Defendants' direct, joint, induced, and/or contributory infringement of the '060 Patent, Preservation has been injured and has been caused significant financial damage.

290. Preservation alleges upon information and belief that Defendants have, knowingly or with willful blindness, willfully infringed one or more claims of the '060 patent. Defendants had knowledge of the Asserted Patents as set forth above, having been advised of the existence and substance of the Asserted Patents by Preservation. Defendants acted with knowledge of the Asserted Patents, and, despite their knowledge or despite that they should have known of an objectively high likelihood that their actions constituted infringement of Preservation's valid patent rights, continue to infringe.

291. This objectively defined risk was either known or so obvious that it should have been known to Defendants. Preservation seeks enhanced damages pursuant to 35 U.S.C. § 284 from Defendants.

292. As a result of Defendants' infringement of the '060 Patent, Preservation has suffered monetary damages. Defendants are thus liable to Preservation in an amount that adequately compensates it for Defendants' infringement, which, by law, cannot be less than a reasonable royalty, together with interest and costs as fixed by this Court under 35 U.S.C. § 284.

COUNT 8

(Direct and indirect infringement of United States Patent No. 6,212,527)

293. Preservation restates and realleges each of the allegations set forth above and incorporates them herein.

Defendants, without permission of Preservation, have been and are presently infringing the '527 Patent, as infringement is defined by 35 U.S.C. § 271(a), by making, using, offering to sell, and selling the Accused Systems and those of third parties including without limitation customers and CDNs. By way of example only, Defendants' Accused Websites such as xvideos.com directly infringe claim 15 of the '527 Patent as follows:

14. A method of creating alternate expressions of content of a multimedia data catalogue comprising: creating a catalogue for said multimedia data, said catalogue containing one or more catalogue elements;

Defendants create a catalogue for multimedia data containing catalogue elements for the Accused Websites. Catalogue elements include types, persons, and keywords associated with multimedia.

creating a first catalogue element, wherein said element is a phrase associating said multimedia data with a plurality of attributes;

Catalogue elements include phrases associated with the multimedia data containing descriptive information for a portion. For example, a clip may be associated with a person or a keyword.

creating a second catalogue element associated with said first catalogue element, wherein said second catalogue element provides an alternative definition of said first catalogue element; and associating said first and said second catalogue elements in a hierarchy of alternate catalogue elements

Catalogue elements also include alternative definitions of other catalogue elements. These include alternative keywords or alternative persons associated with the same video or multimedia. For example, the keyword 'pornstar' is an alternative for the keyword 'pornstars'. Also parent child relationships return alternate expressions of categories and other terms arranged in a hierarchal manner. For example, "Brandi Love" is a species of "pornstars."

294. Defendants' websites creates multiple sets of keywords associated with catalogue elements. The keyword types are associated with multimedia data for search.

15. The method of claim 14 wherein said second catalogue element is a thesaural keyword.

Defendants' websites associate multimedia data using thesaural keyword associations. For example, different keywords referring to the same subject may produce related results.

295. The above description is not intended to comprehensively show how Defendants' Accused Websites infringe the Patents-in-Suit in all cases for all software and/or hardware. Not all infringing features of the Accused Websites are addressed, nor are all infringing features of the Accused Websites mapped to elements of the claims. However, each claim limitation is mapped to at least one infringing feature, Plaintiff reserves the right to rely other features of Defendants' Websites to meet the same limitations of the Patents-in-Suit, or the above described features of the Accused Websites to meet other limitations of the Patents-in-Suit. The descriptions are only meant as exemplary evidence to assist Defendants' in identifying Accused Software and to show how Defendants' Websites plausibly infringe one claim of each of the Patents-in-Suit in one specific instance.

296. Defendants indirectly infringe the '527 Patent by inducing or contributing to the infringement of the '527 Patent, including but not limited to infringement by their customers/consumers, in violation of 35 U.S.C. § 271(b)-(c)&(f). To the extent that Defendants are not directly liable for infringement of the '527 Patent, they collectively and individually induce the operators of the Accused Websites to infringe the '527 Patent.

297. Defendants do not have a license or permission to use the claimed subject matter of the '527 Patent.

298. As a direct and proximate result of Defendants' direct, joint, induced, and/or contributory infringement of the '527 Patent, Preservation has been injured and has been caused significant financial damage.

299. Preservation alleges upon information and belief that Defendants have, knowingly or with willful blindness, willfully infringed one or more claims of the '527 patent. Defendants had knowledge of the Asserted Patents as set forth above, having been advised of the existence

and substance of the Asserted Patents by Preservation. Defendants acted with knowledge of the Asserted Patents, and, despite their knowledge or despite that they should have known of an objectively high likelihood that their actions constituted infringement of Preservation's valid patent rights, continue to infringe.

300. This objectively-defined risk was either known or so obvious that it should have been known to Defendant. Preservation seeks enhanced damages pursuant to 35 U.S.C. § 284 from Defendant.

301. As a result of Defendants' infringement of the '527 Patent, Preservation has suffered monetary damages. Defendants are thus liable to Preservation in an amount that adequately compensates it for Defendants' infringement, which, by law, cannot be less than a reasonable royalty, together with interest and costs as fixed by this Court under 35 U.S.C. § 284.

COUNT 9

(Direct and indirect infringement of United States Patent No. 6,549,911)

302. Preservation restates and realleges each of the allegations set forth above and incorporates them herein.

303. Defendants, without permission of Preservation, have been and are presently infringing the '911 Patent, as infringement is defined by 35 U.S.C. § 271(a), by making, using, offering to sell, and selling the Accused Systems and those of third parties including without limitation customers and CDNs. By way of example only, Defendants' Accused Websites such as xvideos.com directly infringe claim 14 of the '911 Patent as follows:

14. An article of manufacture comprising: a computer usable medium having computer readable program code embodied therein for cataloguing multimedia data using a general indexing structure, the computer readable program code in said article of

manufacture comprising; computer readable program code configured to cause a computer to specify a description for a portion of said multimedia data;

Defendants' Accused Websites are stored and operated on computer systems having computer readable media having code for cataloguing multimedia data using a general indexing structure, including code to cause the computer to specify a description for a portion of the multimedia data. For example, Defendants' Websites prompt its end users to provide tags for portions of multimedia. Defendants' Websites may also assign tags to portions of multimedia.

computer readable program code configured to cause a computer to create a catalogue element for said portion of said multimedia data;

At least one of the data structures containing descriptive information and tags associated with the multimedia portion, among other things, may meet this limitation. Defendants' Websites employ code to create catalogue elements for portions of multimedia data, such as tags provided by its end users or assigned by its systems.

computer readable program code configured to cause a computer to create a plurality of attributes and attribute elements; and computer readable program code configured to cause a computer to create a plurality of relationships between said catalogue element and said plurality of attributes and attribute elements.

Defendants' Websites provides the ability to enter catalogue and attribute information and create elements. It is further used to populate the attributes of an element and create relationships between elements for search.

The above description is not intended to comprehensively show how Defendants' Accused Websites infringe the Patents-in-Suit in all cases for all software and/or hardware. Not all infringing features of the Accused Websites are addressed, nor are all infringing features of the Accused Websites mapped to elements of the claims. However, each claim limitation is mapped to at least one infringing feature, Plaintiff reserves the right to rely other features of Defendants' Websites to meet the same limitations of the Patents-in-Suit, or the above described features of the Accused Websites to meet other limitations of the Patents-in-Suit. The descriptions are only

meant as exemplary evidence to assist Defendants' in identifying Accused Software and to show how Defendants' Websites plausibly infringe one claim of each of the Patents-in-Suit in one specific instance.

304. Defendants indirectly infringe the '911 Patent by inducing or contributing to the infringement of the '911 Patent, including but not limited to infringement by their customers/consumers, in violation of 35 U.S.C. § 271(b)-(c)&(f). To the extent that Defendants are not directly liable for infringement of the '911 Patent, they collectively and individually induce the operators of the Accused Websites to infringe the '911 Patent.

305. Defendants do not have a license or permission to use the claimed subject matter of the '911 Patent.

306. As a direct and proximate result of Defendants' direct, joint, induced, and/or contributory infringement of the '911 Patent, Preservation has been injured and has been caused significant financial damage.

307. Preservation alleges upon information and belief that Defendants have, knowingly or with willful blindness, willfully infringed one or more claims of the '911 patent. Defendants had knowledge of the Asserted Patents as set forth above, having been advised of the existence and substance of the Asserted Patents by Preservation. Defendants acted with knowledge of the Asserted Patents, and, despite their knowledge or despite that they should have known of an objectively high likelihood that their actions constituted infringement of Preservation's valid patent rights, continue to infringe.

308. This objectively defined risk was either known or so obvious that it should have been known to Defendants. Preservation seeks enhanced damages pursuant to 35 U.S.C. § 284 from Defendants.

309. As a result of Defendants' infringement of the '911 Patent, Preservation has suffered monetary damages. Defendants are thus liable to Preservation in an amount that adequately compensates it for Defendants' infringement, which, by law, cannot be less than a reasonable royalty, together with interest and costs as fixed by this Court under 35 U.S.C. § 284.

COUNT 10

(Direct and indirect infringement of United States Patent No. 6,581,071)

310. Preservation restates and realleges each of the allegations set forth above and incorporates them herein.

311. Defendants, without permission of Preservation, have been and are presently infringing the '071 Patent, as infringement is defined by 35 U.S.C. § 271(a), by making, using, offering to sell, and selling the Accused Systems and those of third parties including without limitation customers and CDNs. By way of example only, Defendants' Accused Websites such as xvideos.com include a memory for storing survey information comprising first and second sets of elements stored in memory and thus uses the invention covered by claim 9 of the '071 Patent as follows:

9. A memory for storing survey information accessible by at least one computer program being executed on a machine, said survey information comprising: a first set of elements stored in said memory, said first set of elements usable to define components of a survey;

Defendants' Accused Websites have a first set of elements to define the components of a survey, such as the comment section of the webpage which solicits survey data regarding the embedded multimedia data.

a second set of elements stored in said memory, said second set of elements being associated with at least one of said first set of elements, said second set of elements storing survey responses.

The Websites have a second set of elements associated with the first set of elements that stores survey responses such as provided user comments.

The above description is not intended to comprehensively show how Defendants' Accused Websites infringe the Patents-in-Suit in all cases for all software and/or hardware. Not all infringing features of the Accused Websites are addressed, nor are all infringing features of the Accused Websites mapped to elements of the claims. However, each claim limitation is mapped to at least one infringing feature, Plaintiff reserves the right to rely other features of Defendants' Websites to meet the same limitations of the Patents-in-Suit, or the above described features of the Accused Websites to meet other limitations of the Patents-in-Suit. The descriptions are only meant as exemplary evidence to assist Defendants' in identifying Accused Software and to show how Defendants' Websites plausibly infringe one claim of each of the Patents-in-Suit in one specific instance.

312. Defendants indirectly infringe the '071 Patent by inducing or contributing to the infringement of the '071 Patent, including but not limited to infringement by their customers/consumers, in violation of 35 U.S.C. § 271(b)-(c)&(f). To the extent that Defendants are not directly liable for infringement of the '071 Patent, they collectively and individually induce the operators of the Accused Websites to infringe the '071 Patent.

313. Defendants do not have a license or permission to use the claimed subject matter of the '071 Patent.

314. As a direct and proximate result of Defendants' direct, joint, induced, and/or contributory infringement of the '071 Patent, Preservation has been injured and has been caused significant financial damage.

315. Preservation alleges upon information and belief that Defendants have, knowingly or with willful blindness, willfully infringed one or more claims of the '071 patent. Defendants had knowledge of the Asserted Patents as set forth above, having been advised of the existence

and substance of the Asserted Patents by Preservation. Defendants acted with knowledge of the Asserted Patents, and, despite their knowledge or despite that they should have known of an objectively high likelihood that their actions constituted infringement of Preservation's valid patent rights, continue to infringe.

316. This objectively defined risk was either known or so obvious that it should have been known to Defendants. Preservation seeks enhanced damages pursuant to 35 U.S.C. § 284 from Defendants.

317. As a result of Defendants' infringement of the '071 Patent, Preservation has suffered monetary damages. Defendants are thus liable to Preservation in an amount that adequately compensates it for Defendants' infringement, which, by law, cannot be less than a reasonable royalty, together with interest and costs as fixed by this Court under 35 U.S.C. § 284.

COUNT 11

(Direct and indirect infringement of United States Patent No. 6,574,638)

318. Preservation restates and realleges each of the allegations set forth above and incorporates them herein.

319. Defendants, without permission of Preservation, have been and are presently infringing the '638 Patent, as infringement is defined by 35 U.S.C. § 271(a), by making, using, offering to sell, and selling the Accused Systems and those of third parties including without limitation customers and CDNs. By way of example only, Defendants' Accused Websites such as xvideos.com associate multimedia data with survey data comprising obtaining an association between the data, searching the survey data to identify a catalogue element, and identifying multimedia data using the catalogue element and thus infringes claim 7 of the '638 Patent as follows:

1. In a computer system, associating multimedia data with surveying data comprising: obtaining an association between survey data and at least one catalogue element of a catalogue, said at least one catalogue element associated with said multimedia data;

At least of the data structures containing descriptive information and tags associated with the multimedia portion, among other things, may meet this limitation. Defendants' Accused Websites obtains survey data from end users such as video comments, title, categories, production, tags, date added, and date featured for a specific multimedia clip. This data is associated with the multimedia clip.

searching said survey data to identify said at least one catalogue element;

Comments, tags, production, categories, data added, and other associated user data are searched, located, and displayed alongside the clips, and other media hosted by Defendants' Accused Websites.

identifying said multimedia data using said at least one catalogue element.

The multimedia data is identified using the associated user data for display.

7. The method of claim 1 wherein said catalogue element is a keyword, said identifying said multimedia data further comprises: identifying at least one phrase associated with said keyword, said at least one phrase being associated with said multimedia data.

The user data is associated with portions of the multimedia data

As an example of indirect infringement, end users of the www.xvideos.com website participate in surveys whereby an end user receives and answers one or more questions related to multimedia data and indirectly infringe at least one claims of the '638 Patent. The above description is not intended to comprehensively show how Defendants' Accused Websites infringe the Patents-in-Suit in all cases for all software and/or hardware. Not all infringing features of the Accused Websites are addressed, nor are all infringing features of the Accused Websites mapped to elements of the claims. However, each claim limitation is mapped to at least one infringing feature, Plaintiff reserves the right to rely other features of Defendants' Websites

to meet the same limitations of the Patents-in-Suit, or the above described features of the Accused Websites to meet other limitations of the Patents-in-Suit. The descriptions are only meant as exemplary evidence to assist Defendants' in identifying Accused Software and to show how Defendants' Websites plausibly infringe one claim of each of the Patents-in-Suit in one specific instance.

320. Defendants indirectly infringe the '638 Patent by inducing or contributing to the infringement of the '638 Patent, including but not limited to infringement by their customers/consumers, in violation of 35 U.S.C. § 271(b)-(c)&(f). To the extent that Defendants are not directly liable for infringement of the '638 Patent, they collectively and individually induce the operators of the Accused Websites to infringe the '638 Patent.

321. Defendants do not have a license or permission to use the claimed subject matter of the '638 Patent.

322. As a direct and proximate result of Defendants' direct, joint, induced, and/or contributory infringement of the '638 Patent, Preservation has been injured and has been caused significant financial damage.

323. Preservation alleges upon information and belief that Defendants have, knowingly or with willful blindness, willfully infringed one or more claims of the '638 patent. Defendants had knowledge of the Asserted Patents as set forth above, having been advised of the existence and substance of the Asserted Patents by Preservation. Defendants acted with knowledge of the Asserted Patents, and, despite their knowledge or despite that they should have known of an objectively high likelihood that their actions constituted infringement of Preservation's valid patent rights, continue to infringe.

324. This objectively defined risk was either known or so obvious that it should have been known to Defendants. Preservation seeks enhanced damages pursuant to 35 U.S.C. § 284 from Defendants.

325. As a result of Defendants' infringement of the '638 Patent, Preservation has suffered monetary damages. Defendants are thus liable to Preservation in an amount that adequately compensates it for Defendants' infringement, which, by law, cannot be less than a reasonable royalty, together with interest and costs as fixed by this Court under 35 U.S.C. § 284.

JURY DEMAND

326. Plaintiff Preservation hereby requests a trial by jury on all matters to which it is entitled to trial by jury pursuant to Rule 38 of the Federal Rules of Civil Procedure.

PRAYER FOR RELIEF

WHEREFORE, Plaintiff Preservation respectfully requests that the Court:

- A. Enter judgment that Defendants directly infringe, contribute to infringement, or induce others to infringe one or more claims of the Asserted Patents literally and/or under the doctrine of equivalents;
- B. Award Plaintiff past and future damages together with prejudgment and post-judgment interest to compensate for the infringement by Defendants of the Asserted Patents in accordance with 35 U.S.C. § 284;
- C. Declare this case exceptional pursuant to 35 U.S.C. § 285; and
- D. Award Plaintiff Preservation its costs, disbursements, attorney's fees, and such further and additional relief as deemed appropriate by this Court.

Dated: August 1, 2022

Respectfully submitted,

/s/ Andrew G. DiNovo

Andrew G. DiNovo

Texas State Bar No. 00790594

adinovo@dinovoprice.com

Adam G. Price

Texas State Bar No. 24027750

aprice@dinovoprice.com

Nicole E. Glauser

Texas State Bar. No. 24050694

nglauser@dinovoprice.com

Michael French (*Pro Hac Vice*)

Texas State Bar. No. 24116392

mfrench@dinovoprice.com

DINOVO PRICE LLP

7000 N. MoPac Expressway, Suite 350

Austin, Texas 78731

Telephone: (512) 539-2626

Telecopier: (512) 539-2627

COUNSEL FOR PLAINTIFF

PRESERVATION TECHNOLOGIES LLC

CERTIFICATE OF SERVICE

I hereby certify that on August 1, 2022, I electronically filed the foregoing with the Clerk of the Court using the CM/ECF system, which will send notification of such filing to all counsel of record.

/s/ Andrew G. DiNovo
Andrew G. DiNovo