

**IN THE UNITED STATES DISTRICT COURT
FOR THE DISTRICT OF DELAWARE**

NEXGEN CONTROL SYSTEMS, LLC,

Plaintiff,

v.

**INFINEON TECHNOLOGIES AG AND
INFINEON TECHNOLOGIES AMERICAS
CORPORATION,**

Defendants.

Civil Action No. _____

JURY TRIAL DEMANDED

COMPLAINT FOR PATENT INFRINGEMENT

NexGen Control Systems, LLC (“NexGen” or “Plaintiff”) bring this action and make the following allegations of patent infringement relating to U.S. Patent No. 8,278,855 (the “855 patent”) (the “patent-in-suit”). Defendants Infineon Technologies AG and Infineon Technologies Americas Corporation (collectively, “Infineon” or “Defendants”) infringe the patent-in-suit in violation of the patent laws of the United States of America, 35 U.S.C. § 1 *et seq.*

INTRODUCTION

1. NexGen’s portfolio of over 950 patent assets encompasses core technologies in the fields of semiconductors and power management. NexGen’s patents arose from the research and development efforts of Mitsubishi Electric Corporation.

2. In an effort to facilitate the licensing of Mitsubishi’s foundational technology, NexGen is pursuing remedies for infringement of its patents in venues throughout the world. NexGen is pursuing infringement actions against several large automotive companies throughout the United States, Japan, the People’s Republic of China, and Germany.

3. Highlighting the importance of the patent-in-suit is the fact that the NexGen’s patent portfolio has been cited by over 2,500 U.S. and international patents and patent applications

assigned to a wide variety of the largest producers of automotive and semiconductor technologies.

NexGen's patents have been cited by companies such as:

- DENSO Corporation¹
- Robert Bosch GmbH²
- Toyota Motor Corporation³
- Hitachi, Ltd.⁴
- Hyundai Motor Company⁵
- Siemens AG⁶
- Continental Automotive GmbH⁷
- Toshiba Corporation⁸
- Nissan Motor Co., Ltd.⁹
- Panasonic Corporation¹⁰

CO-PENDING ENFORCEMENT PROCEEDINGS IN CHINA AND EUROPE

4. NexGen's portfolio of over 950 patent assets encompasses core technologies in the fields of automotive electrical power generation, transformation, and regulation, as well as lifesaving safety innovations. The patent portfolio held by NexGen is international in scope and includes numerous European, Chinese, and Japanese patent grants.

5. To facilitate the licensing of Mitsubishi Electric Corporation's foundational technology, NexGen is pursuing remedies for infringement of its patents in venues throughout the world.

¹ See, e.g., U.S. Patent Nos. 6,906,574; 8,045,345; 8,489,262; 8,083,015; 8,427,004; 8,077,491; and 8,278,855.

² See, e.g., U.S. Patent Nos. 6,906,574 and 7,772,806.

³ See, e.g., U.S. Patent Nos. 8,489,262; 8,083,015; 8,427,004; 8,077,491; and 8,278,855.

⁴ See, e.g., U.S. Patent Nos. 8,531,150; 7,772,806; 8,045,345; 8,489,262; 8,547,713; 8,427,004; and 8,077,491.

⁵ See, e.g., U.S. Patent Nos. 8,531,150; 7,772,806; 8,045,345 and 8,083,015.

⁶ See, e.g., U.S. Patent Nos. 7,772,806 and 8,278,855.

⁷ See, e.g., U.S. Patent Nos. 7,772,806 and 8,083,015.

⁸ See, e.g., U.S. Patent Nos. 8,489,262; 8,427,004; 8,278,855; and 7,772,806.

⁹ See, e.g., U.S. Patent Nos. 8,489,262; 8,083,015; 8,427,004; and 8,278,855.

¹⁰ See, e.g., U.S. Patent Nos. 8,045,345; 8,547,713; and 8,278,855.

6. NexGen is concurrently litigating patent infringement claims against Infineon Technology (Wuxi) Co., Ltd., in the Shanghai Intellectual Property Court of the People's Republic of China in (2021) Hu 73 Zhiminchu No. 1580 [(2021) 沪73知民初1580号]. The Complaint alleges that Infineon Technology (Wuxi) Co., Ltd. has infringed Chinese Patent No. ZL200780100586.7.

7. NexGen is also concurrently litigating patent infringement claims against NXP (China) Management Co., Ltd. and Arrow Electronics (Shanghai) Co., Ltd. NexGen's complaint against NXP (China) Management Co., Ltd. and others for patent infringement was accepted by the Shanghai Intellectual Property Court of the People's Republic of China. The case number for NexGen's infringement action is: (2023) 沪73知民初72号.

THE PARTIES

NEXGEN CONTROL SYSTEMS, LLC

8. NexGen Control Systems, LLC ("NexGen") is a Delaware limited liability company with its principal place of business at 225 S. 6th Street, Suite 3900, Minneapolis, Minnesota 55402. NexGen is the owner by assignment of all right, title, and interest of the patent-in-suit.

INFINEON DEFENDANTS

9. Infineon Technologies AG is a corporation organized and existing under the laws of the Federal Republic of Germany with its principal place of business at Am Champeon 1-15 85579 Neubiberg, Germany.

10. Infineon Technologies Americas Corporation is a Delaware corporation. Infineon Technologies Americas Corporation may be served through its registered agent Corporation Service Company d/b/a CSC – 251 Little Falls Drive, Wilmington, Delaware 19808.

JURISDICTION AND VENUE

11. This action arises under the patent laws of the United States, Title 35 of the United States Code. Accordingly, this Court has exclusive subject matter jurisdiction over this action under 28 U.S.C. §§ 1331 and 1338(a).

12. This Court has personal jurisdiction over Infineon in this action because Infineon has committed acts within the State of Delaware giving rise to this action and has established minimum contacts with this forum such that the exercise of jurisdiction over Infineon would not offend traditional notions of fair play and substantial justice. Defendants directly and/or through subsidiaries or intermediaries (including distributors, retailers, and others), have committed and continue to commit acts of infringement in this District by, among other things, offering to sell and selling products and/or services that infringe the patent-in-suit. Moreover, Infineon Technologies Americas Corp. is a corporation organized and existing under the laws of the State of Delaware.

13. Venue is proper in this district under 28 U.S.C. §§ 1391(b)-(d) and 1400(b). Defendant Infineon Technologies Americas Corp. is a corporation organized and existing under the laws of the State of Delaware, and therefore resides in the District of Delaware as defined by 28 U.S.C. § 1400(b). Venue in this District is proper as to Defendant Infineon Technologies AG because Infineon Technologies AG is a foreign corporate entity; venue is therefore proper in any judicial District, including the District of Delaware, where personal jurisdiction is proper.

THE ASSERTED PATENT

U.S. PATENT NO. 8,278,855

14. U.S. Patent No. 8,278,855 (the “855 patent”) entitled, *Controller of Motor Preventing an Increase in Inverter Loss*, was filed on October 29, 2007. NexGen is the owner by

assignment of the '855 patent. A true and correct copy of the '855 patent is attached hereto as Exhibit 1.

15. The '855 patent discloses novel controllers of electric motors.

16. The inventions disclosed in the '855 patent improve the efficiency of electric motor configurations by ensuring the inverter does not increase inverter loss beyond the capacity of the motor.

17. The '855 patent discloses a motor controller with a voltage-command generating unit that generates a pulse-width modulation signal to control a switching element provided in an inverter, to the inverter connected to a direct-current power source and outputting a three-phase alternating current of an arbitrary frequency and an arbitrary voltage to an alternating-current motor.

18. The '855 patent discloses a motor controller with a current-command generating unit that generates and outputs a current command to cause the alternating-current motor to generate torque based on an input torque command.

19. The '855 patent discloses a motor controller wherein the current-command generating unit is configured to output the current-command that is calculated based on a relationship between the torque command and a state quantity of the alternating-current motor, to maintain a terminal voltage of the alternating-current motor to a maximum value that can be generated under the direct-current power source, and to output a current command adjusted to maintain or decrease a loss of the inverter under a predetermined condition in which the loss of the inverter increases or estimated to increase.

20. The '855 patent has been cited by 43 patents and patent applications as relevant prior art. Specifically, patents issued to the following companies have cited the '855 patent as relevant prior art:

- Toshiba Corporation
- Toyota Motor Corporation
- DENSO Corporation
- Nissan Motor Co., Ltd.
- Panasonic Corporation
- Dongfang Electric Corporation
- Siemens AG
- Ford Global Technologies, LLC
- Rockwell Automation Technologies, Inc.
- Hamilton Sundstrand Corporation
- Control Tech Ltd.
- SK Hynix Inc.
- Renault SA
- Renesas Electronics Corporation
- LG Electronics Inc.
- Sinfonia Technology Co., Ltd.

COUNT I
INFRINGEMENT OF U.S. PATENT NO. 8,278,855

21. Plaintiff references and incorporates by reference the preceding paragraphs of this Complaint as if fully set forth herein.

22. Infineon designs, makes, uses, sells, and/or offers for sale in the United States electric motor controllers.

23. Infineon designs, makes, sells, offers to sell, imports, and/or uses the following products: Infineon iMotion IMM100 Series and IMC100 Series products (including, but not limited to, the following models: IMC101T-F048, IMC101T-F064, IMC101T-Q048, IMC101T-T038, IMC102T-F048, IMC102T-F064, IMM101T-015M, IMM101T-046M, IMM101T-056M,

IMM102T-015M, IMM102T-046M, and IMM102T-056M) (collectively, the “Infineon ‘855 Product(s)”).

24. One or more Infineon subsidiaries and/or affiliates use the Infineon ‘855 Products in regular business operations.

25. The Infineon ‘855 Products comprise a motor controller for sensing and control of AC motors as shown in the below excerpt from Infineon documentation.

1 Overview

IMM100T modules contain a processor core that can address the real-time control needs of motor control. It can use low-cost single shunt or leg shunts as motor current feedback by a combination of on-chip hardware and firmware. Complex FOC control algorithms either sensorless or with sensors, as well as system level control can be easily implemented inside IC and meet fan, pump and compressor applications requirements. A standby mode helps to decrease system power consumption when the motor is stopped. The high-voltage level shifting function with boot strap diode function is integrated into the gate driver IC. The device also contains the six low-loss 500V power FET or 650V CoolMOS which form the three phase inverter circuit.

Infineon iMOTION™ IMM101T/IMM102T - Smart IPM for motor control, INFINEON DATASHEET V1.2 at 1 (April 24, 2020) (emphasis added).

26. The Infineon ‘855 Products comprise a voltage-command generating unit that generates a pulse-width modulation (PWM) signal to control a switching element provided in an inverter. Specifically, the Infineon Products include a six low-loss 500V power FET or 650V CoolMOS which forms a three-phase inverter.

1 Overview

IMM100T modules contain a processor core that can address the real-time control needs of motor control. It can use low-cost single shunt or leg shunts as motor current feedback by a combination of on-chip hardware and firmware. Complex FOC control algorithms either sensorless or with sensors, as well as system level control can be easily implemented inside IC and meet fan, pump and compressor applications requirements. A standby mode helps to decrease system power consumption when the motor is stopped. The high-voltage level shifting function with boot strap diode function is integrated into the gate driver IC. The device also contains the six low-loss 500V power FET or 650V CoolMOS which form the three phase inverter circuit.

Infineon iMOTION™ IMM101T/IMM102T - Smart IPM for motor control, INFINEON DATASHEET V1.2 at 1 (April 24, 2020) (emphasis added).

27. The Infineon ‘855 Products include technology for controlling the switching element in an inverter.

28. The following diagram from Infineon documentation shows the Infineon ‘855 Products contain a three-phase AC inverter that is connected to a DC power supply.

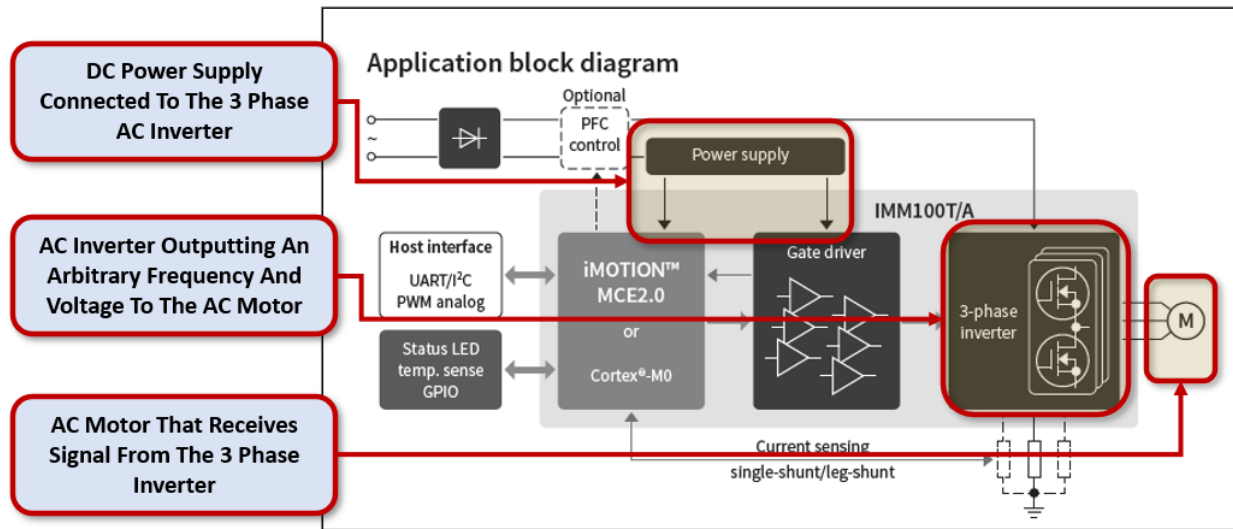

Infineon iMotion IMM100 Fully Integrated Smart IPM for BLDC Motor Control Product Brief, INFINEON DOCUMENTATION at 1 (March 2019) (annotation added).

29. The DC Bus Voltage for the IMM101T product ranges from 120V to 320V as shown in the below excerpt from Infineon documentation. This DC Bus Voltage is supplying the power to the AC Inverter.

DC Bus Voltage		
Maximum DC bus voltage	EVAL-IMM101T-015	380 V
	EVAL-IMM101T-046	
Minimum DC bus voltage	EVAL-IMM101T-015	120 V
	EVAL-IMM101T-046	

AN2019-17 EVAL-IMM101T User Manual, INFINEON APPLICATION NOTE at 6 (June 18, 2019).

30. The following diagram from Infineon documentation shows how the Gate Driver in the Infineon ‘855 Products generates a PWM signal that controls a switching element in a

connected inverter. In the below diagram the Gate Driver unit in the Infineon ‘855 Products is generating a signal that is transmitted to the connected inverter.

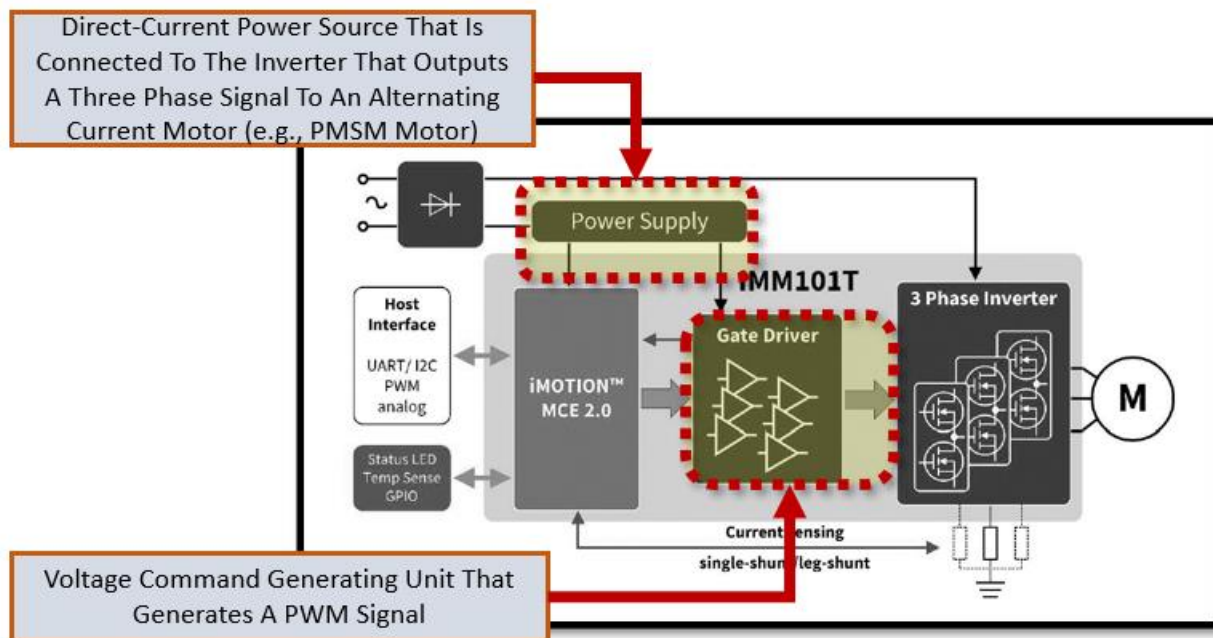

Infineon iMotion IMM100 Fully Integrated Smart IPM for BLDC Motor Control Product Brief, INFINEON DOCUMENTATION at 1 (March 2019) (annotation added).

31. Further, the Infineon ‘855 Products contain circuitry including a gate driver that enables sending signals to the connected three-phase inverter. These signals control the inverter and through the inverter control the PMSM motor.

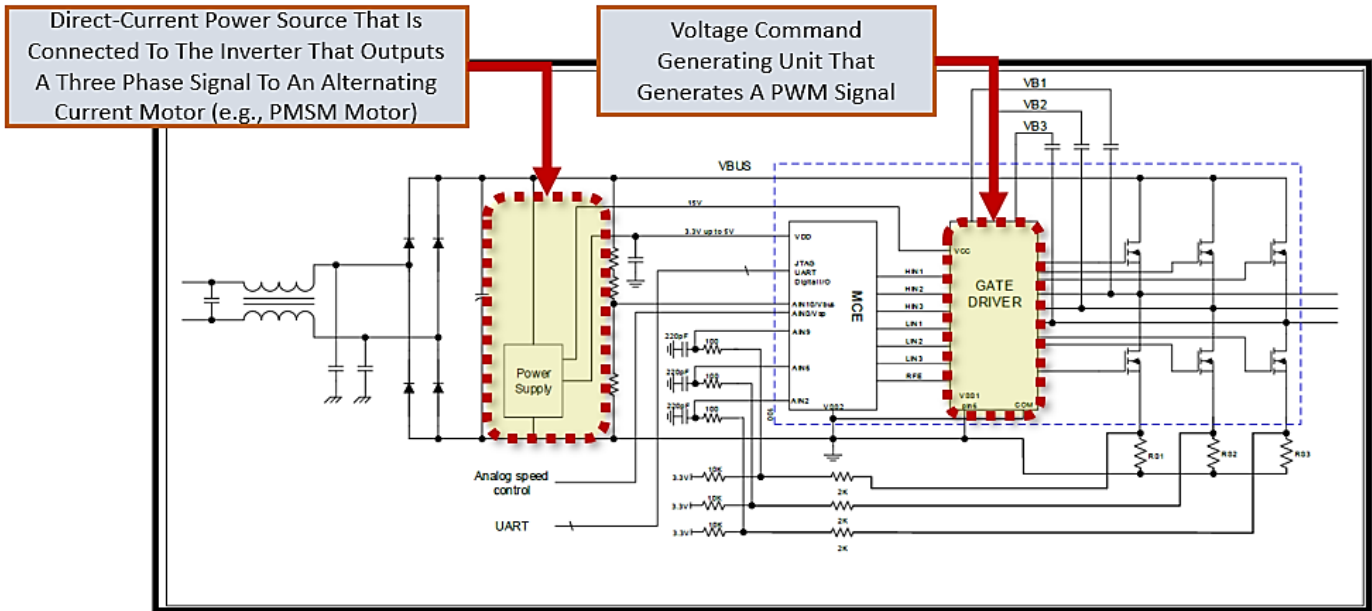

AN2019-17 EVAL-IMM101T User Manual, INFINEON APPLICATION NOTE, INFINEON DOCUMENTATION at 28 (June 18, 2019) (annotation added).

32. The Infineon ‘855 Products include a voltage-command generating unit that generates a pulse-width modulation (PWM) signal to control a switching element in an inverter. The inverter is connected to a DC power source and outputs a three-phase AC current of arbitrary frequency and voltage to the AC motor. The voltage-command generating unit in the Infineon ‘855 Products determine the desired voltage and frequency for the AC motor. Based on this information, the Infineon ‘855 Products generate a PWM signal that controls the switching element in the inverter to produce the desired AC output waveform.

33. The PWM signal generated by the Infineon ‘855 Products adjusts the on and off time of the switching element in the inverter. The duration of each on and off cycle is controlled by the width of the PWM signal, which is adjusted by the voltage-command generating unit. By adjusting the width of the PWM signal, the voltage-command generating unit of the Infineon ‘855 Products control the amplitude and frequency of the AC output waveform, which in turn controls the speed and torque of the AC motor. By generating a PWM signal that controls the switching

element in the inverter, the Infineon ‘855 Products can produce a three-phase AC current of arbitrary frequency and voltage, which in turn controls the speed and torque of the AC motor.

34. The below excerpt from Infineon documentation shows the voltage command generating unit in the Infineon ‘855 Products sends a PWM signal to the inverter that is connected to a direct current power source (*e.g.*, DC Bus Voltage).

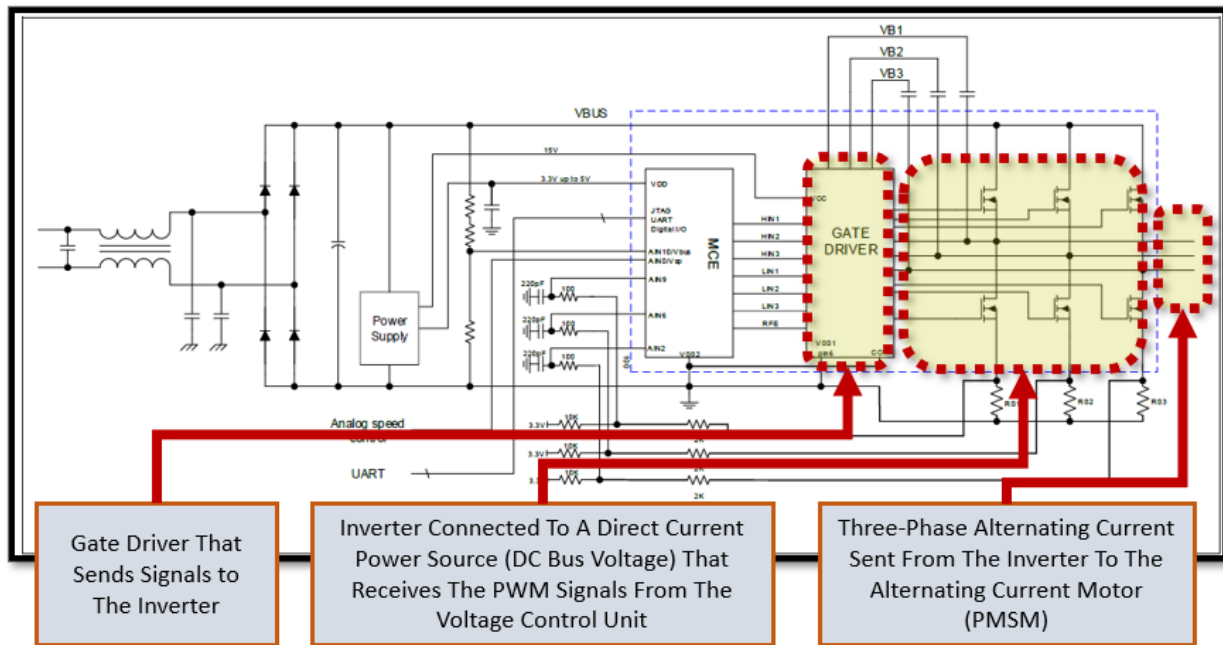

AN2019-17 EVAL-IMM101T User Manual, INFINEON APPLICATION NOTE, INFINEON DOCUMENTATION at 28 (June 18, 2019) (annotation added).

35. The Infineon ‘855 Products comprise a controller of a motor that includes a voltage-command generating unit that generates a pulse-width modulation signal to control a switching element provided in an inverter, to the inverter connected to a direct-current power source and outputting a three-phase alternating current of an arbitrary frequency and an arbitrary voltage to an alternating-current motor.

36. The Infineon ‘855 Products comprise a motor controller that includes a current-command generating unit that generates and outputs a current command to induce the AC motor to generate torque based on an input torque command. Specifically, the Infineon ‘855 Products

Once the current command is generated and outputted by the Infineon ‘855 Products, it is sent to the inverter, which converts the DC power from the power source into a three-phase AC current with the desired voltage and frequency. The AC current is then fed to the motor, where it induces the generation of torque in the motor.

39. The Current Command generating unit (current control) in the Infineon ‘855 Products generates an output current that is fed into the input torque command that is sent to the AC Motor to generate torque.

MCE PFC is multiplier based control, which means there are two control loops in PFC, an inner current loop and an outer voltage loop, along with a feedforward component. The output of the voltage controller is multiplied by the rectified AC voltage to produce a current reference. The output of the current controller is added to the feedforward output to generate the modulation command. This PFC control scheme requires sensing of the inductor current, AC line voltage and DC bus voltage.

MCE supports two types of PFC topologies.

1. Boost Mode PFC
2. Totem-Pole PFC

Infineon iMotion Motion Control Engine Software Reference Manual Version 1.34, INFINEON DOCUMENTATION at 64 (September 17, 2021) (emphasis added).

40. The Infineon ‘855 Products comprise a motor controller that includes a current-command generating unit that calculates a current command based on the relationship between the torque command and a state quantity of the AC motor. The current-command generating unit is also designed to maintain the terminal voltage of the AC motor at the maximum value that can be generated under the DC power source, and to adjust the current command to maintain or decrease the inverter loss under certain conditions where the loss increases or is expected to increase.

41. The Infineon ‘855 Products includes a current-command generating unit that calculates a current command based on the relationship between the torque command and a state quantity of the AC motor. The current-command generating unit maintains the terminal voltage of the AC motor at the maximum value that can be generated under the DC power source. This is

done by the Infineon ‘855 Products to ensure that the motor operates at maximum efficiency and power output.

42. The Infineon ‘855 Products use the current control unit to generate an input torque command. Specifically, the Infineon Products use the current loops to drive the motor currents needed to generate torque. The current loops calculate the inverter voltages needed to cause the desired torque in the AC motor.

The speed controller calculates the motor torque required to follow the target speed. While the current loops drive the motor currents needed to generate this torque. The proportional plus integral (PI) speed loop compensator acts on the error between the target speed and the actual (estimated) speed. The integral term forces the steady state error to zero while the proportional term improves the high frequency response. The PI compensator gains are adjusted depending on the motor and load characteristics to meet the target dynamic performance. The limiting function on the output of the PI compensator prevents integral windup and maintains the motor currents within the motor and drive capability.

The current loops calculate the inverter voltages to drive the motor currents needed to generate the desired torque. Field oriented control (FOC) uses the Clarke transform and a vector rotation to transform the motor winding currents into two quasi dc components, an I_d component that reinforces or weakens the rotor field and an I_q component that generates motor torque.

Infineon iMotion Motion Control Engine Software Reference Manual Version 1.34, INFINEON DOCUMENTATION at 11 (September 17, 2021) (emphasis added).

43. The current-command generating unit of the Infineon ‘855 Products is designed to adjust the current command to maintain or decrease the inverter loss under certain conditions where the loss increases or is expected to increase. The inverter loss can increase due to various reasons such as overcurrent, overheating, or other factors. To prevent this, the Infineon ‘855 Products adjust the current command to reduce the load on the inverter and prevent it from overheating. By calculating a current command based on the relationship between the torque command and a state quantity of the AC motor, and by adjusting the current command to maintain or decrease the inverter loss, the Infineon ‘855 Products can regulate the speed and torque of the AC motor.

44. The following excerpt from Infineon documentation shows how the Infineon ‘855 Products comprise a motor controller that outputs a signal to an inverter that powers an AC motor. The highlighted section below shows the voltage command that is sent to the inverter for controlling an AC Motor.

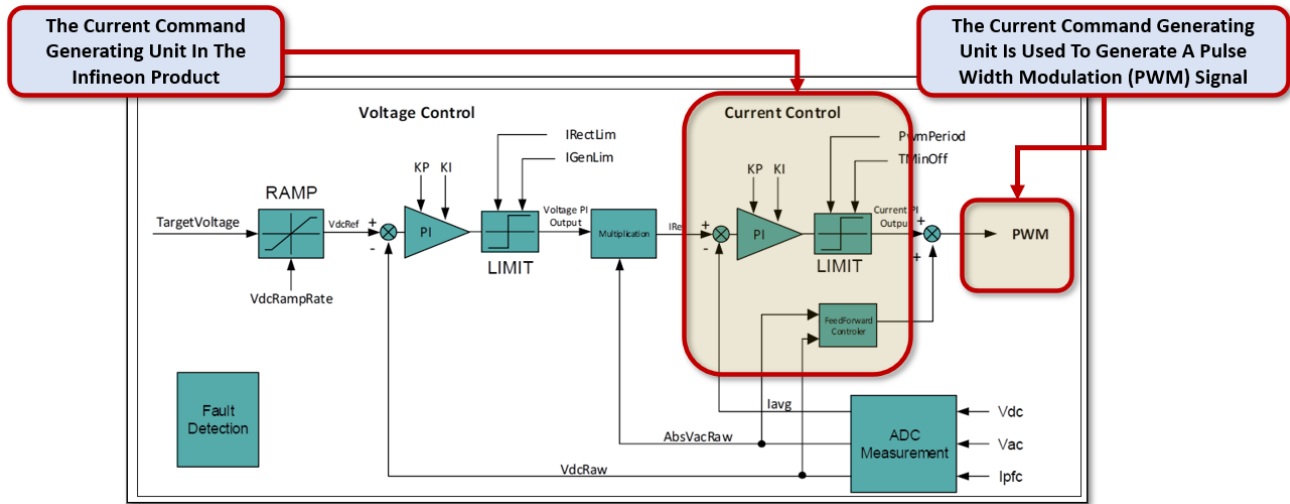

Infineon iMotion Motion Control Engine Reference Manual Version 1.3, INFINEON DOCUMENTATION at 64 (April 26, 2020) (annotation added).

45. The Infineon ‘855 Products include a controller of a motor that contains a current-command generating unit that generates and outputs a current command to cause the alternating-current motor to generate torque based on an input torque command.

46. The Infineon ‘855 Products comprise a controller of a motor that includes a current-command generating unit that is configured to output the current-command that is calculated based on a relationship between the torque command and a state quantity of the alternating-current motor, to maintain a terminal voltage of the alternating-current motor to a maximum value that can be generated under the direct-current power source, and to output a current command adjusted to maintain or decrease a loss of the inverter under a predetermined condition in which the loss of the inverter increases or estimated to increase.

47. The Infineon ‘855 Products comprise a current-command generating unit that is configured to output a current-command that is calculated based on a relationship between the torque command and the state quality of the alternating motor. The below excerpt from Infineon documentation shows that current-command that is generated using the torque command and state quantity of the alternating current motor.

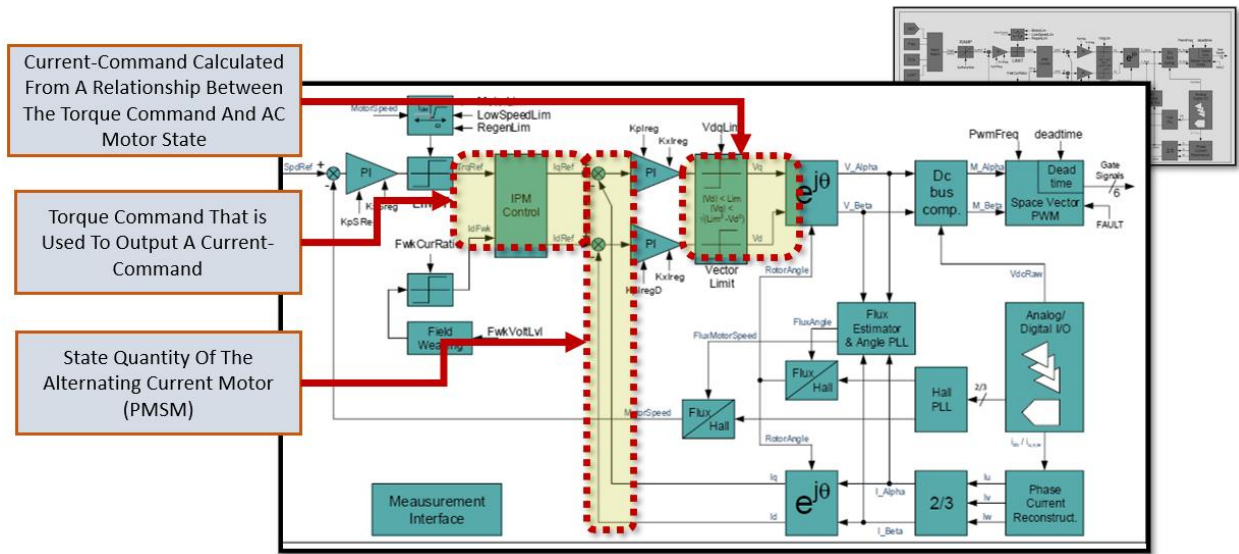

Infineon iMotion Motion Control Engine Reference Manual Version 1.3, INFINEON DOCUMENTATION at 11 (April 26, 2020) (annotation added).

48. The current command is generated by the Infineon ‘855 Products to maintain a terminal voltage of the alternating current motor (PMSM) where the terminal voltage is a maximum value that can be generated by the direct current power source that is driving the inverter (DC voltage). Specifically, during the tuning process (stator inductance) the maximum terminal voltage that can be maintained by the motor is calculated. The current command that is generated by the Infineon Products is adjusted to maintain or decrease a loss of the inverter under a condition in which the loss of the inverter is estimated to increase. Specifically, during the power stage characterization of the Infineon products the inverter error (loss) is measured and that error is used

to adjust the current command. The following excerpt from Infineon documentation describes the measurement which represents inverter loss.

limited by the dc bus voltage. In this situation, the field weakening controller generates a negative I_d to oppose the rotor magnet field that reduces the winding back EMF. This enables operation at higher speeds but at a lower torque output. The controller includes a compensator that adjusts the I_d current to maintain the motor voltage magnitude within the bus voltage limit.

The rotor magnet position estimator consists of a flux estimator and PLL. Flux is calculated based on feedback current, estimated voltages (based on dc bus feedback voltage and modulation index) and motor parameters (inductance and resistance). The output of the flux estimator represents rotor magnet flux in the Alpha-Beta (stationary orthogonal frame, u-phase aligned with Alpha) two-phase components. The angle and frequency phase locked loop (PLL) estimates the flux angle and speed from the rotor magnet flux vector in Alpha-Beta components. The vector rotation calculates the error between the rotor flux angle and the estimated angle. The PI compensator and integrator in the closed loop path force angle and frequency estimate to track the angle and frequency of the rotor flux. The motor speed is derived from the rotor frequency according to the number of rotor poles.

Infineon iMotion Motion Control Engine Software Reference Manual Version 1.34, INFINEON DOCUMENTATION at 12 (September 17, 2021) (emphasis added).

49. The following diagram from Infineon documentation shows the estimated inverter loss is measured through signals sent from the inverter and PMSM sensor.

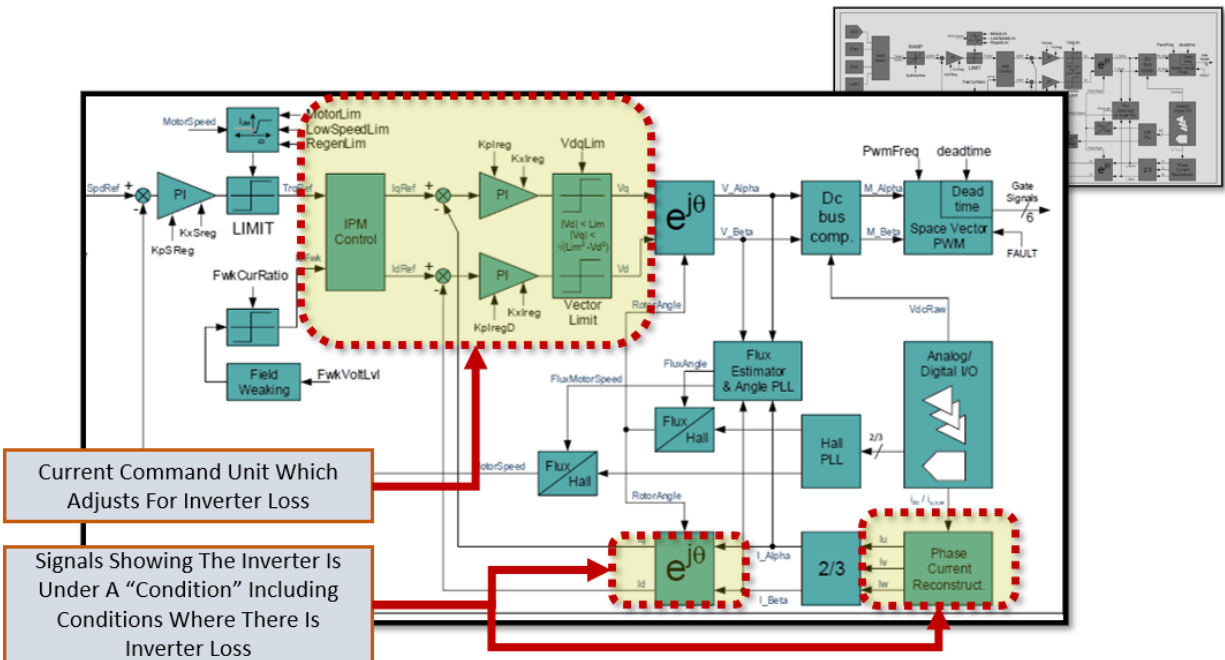

Infineon iMotion Motion Control Engine Reference Manual Version 1.3, INFINEON DOCUMENTATION at 11 (April 26, 2020) (annotation added).

50. The Infineon ‘855 Products are available to businesses and individuals throughout the United States.

51. The Infineon ‘855 Products are provided to businesses and individuals located in the State of Delaware.

52. By making, using, testing, offering for sale, and/or selling drive circuits for driving power semiconductor devices, including but not limited to the Infineon ‘855 Products, Infineon has injured Plaintiff and is liable to Plaintiff for directly infringing one or more claims of the ‘855 patent, including at least claim 1 pursuant to 35 U.S.C. § 271(a).

53. Infineon also indirectly infringes the ‘855 patent.

54. Infineon has had knowledge of the ‘855 patent since at least December 31, 2021, by way of service of the Complaint against Infineon Technology (Wuxi) Co., Ltd., in the Shanghai Intellectual Property Court of the People’s Republic of China in (2021) Hu 73 Zhiminchu No. 1580 [(2021) 沪73知民初1580号]. The Complaint alleges that Infineon Technology (Wuxi) Co., Ltd., which is a Chinese affiliate of Defendants, has infringed Chinese Patent No. ZL200780100586.7, which is the Chinese counterpart of the ‘855 patent.

55. In the alternative, Infineon has had knowledge of the ‘855 patent since at least service of this Complaint or shortly thereafter, and Infineon knew of the ‘855 patent and knew of its infringement, including by way of this lawsuit.

56. Infineon indirectly infringes the ‘855 patent by actively inducing infringement under 35 U.S.C. § 271(b).

57. Infineon intended to induce patent infringement by third-party customers and users of the Infineon ‘855 Products and had knowledge that the inducing acts would cause infringement or was willfully blind to the possibility that its inducing acts would cause infringement. Infineon

specifically intended and was aware that the normal and customary use of the accused products would infringe the ‘855 patent. Infineon performed the acts that constitute induced infringement, and would induce actual infringement, with knowledge of the ‘855 patent and with the knowledge that the induced acts would constitute infringement. For example, Infineon provides the Infineon ‘855 Products that have the capability of operating in a manner that infringe one or more of the claims of the ‘855 patent, including at least claim 1, and Infineon further provides documentation and training materials that cause customers and end users of the Infineon ‘855 Products to utilize the products in a manner that directly infringe one or more claims of the ‘855 patent.¹¹ By providing instruction and training to customers and end-users on how to use the Infineon ‘855 Products in a manner that directly infringes one or more claims of the ‘855 patent, including at least claim 1, Infineon specifically intended to induce infringement of the ‘855 patent. Infineon engaged in such inducement to promote the sales of the Infineon ‘855 Products, e.g., through Infineon user manuals, product support, marketing materials, and training materials to actively induce the users of the accused products to infringe the ‘855 patent. Accordingly, Infineon has induced and continues to induce users of the accused products to use the accused products in their ordinary and customary way to infringe the ‘855 patent, knowing that such use constitutes infringement of the ‘855 patent.

58. Infineon indirectly infringes the ‘855 patent by contributing to the infringement by its customers and end users under 35 U.S.C. § 271(c) by making, using, importing, selling, or

¹¹ See e.g., *Infineon iMotion Motion Control Engine Reference Manual Version 1.3*, INFINEON DOCUMENTATION (April 26, 2020); *Infineon iMotion Motion Control Engine Software Reference Manual Version 1.34*, INFINEON DOCUMENTATION (September 17, 2021); *AN2019-17 EVAL-IMM101T User Manual*, INFINEON APPLICATION NOTE, INFINEON DOCUMENTATION (June 18, 2019); *Infineon iMotion IMM100 Fully Integrated Smart IPM for BLDC Motor Control Product Brief*, INFINEON DOCUMENTATION (March 2019); and *Infineon iMOTION IMM101T/IMM102T - Smart IPM for motor control*, INFINEON DATASHEET V1.2 (April 24, 2020).

offering to sell within the United States the Infineon ‘855 Products, which incorporate or constitute a material part of the inventions claimed by the ‘855 patent. Infineon does so knowing that these products are especially made or especially adapted for uses that infringe the ‘855 patent, and not staple articles or commodities of commerce suitable for substantial non-infringing use.

59. The ‘855 patent is well-known within the industry as demonstrated by multiple citations to the ‘855 patent in published patents and patent applications assigned to technology companies and academic institutions. Infineon is utilizing the technology claimed in the ‘855 patent without paying a reasonable royalty. Infineon is infringing the ‘855 patent in a manner best described as willful, wanton, malicious, in bad faith, deliberate, consciously wrongful, flagrant, or characteristic of a pirate.

60. To the extent applicable, the requirements of 35 U.S.C. § 287(a) have been met with respect to the ‘855 patent.

61. As a result of Infineon’s infringement of the ‘855 patent, Plaintiff has suffered monetary damages, and seeks recovery in an amount adequate to compensate for Infineon’s infringement, but in no event less than a reasonable royalty for the use made of the invention by Infineon together with interest and costs as fixed by the Court.

PRAYER FOR RELIEF

WHEREFORE, Plaintiff NexGen Control Systems, LLC respectfully requests that this Court enter:

- A. A judgment in favor of Plaintiff that Infineon has infringed, either literally and/or under the doctrine of equivalents, the ‘855 patent;
- B. An award of damages resulting from Infineon’s acts of infringement in accordance with 35 U.S.C. § 284;

- C. A judgment and order finding that Infineon's infringement was willful, wanton, malicious, bad-faith, deliberate, consciously wrongful, flagrant, or characteristic of a pirate within the meaning of 35 U.S.C. § 284 and awarding to Plaintiff enhanced damages.
- D. A judgment and order finding that this is an exceptional case within the meaning of 35 U.S.C. § 285 and awarding to Plaintiff its reasonable attorneys' fees against Infineon.
- E. Any and all other relief to which Plaintiff may show itself to be entitled.

JURY TRIAL DEMANDED

Pursuant to Rule 38 of the Federal Rules of Civil Procedure, Plaintiff NexGen Control Systems, LLC requests a trial by jury of any issues so triable by right.

Dated: March 22, 2023

BAYARD, P.A.

OF COUNSEL:

Dorian S. Berger (CA SB No. 264424)
Daniel P. Hipskind (CA SB No. 266763)
Erin E. McCracken (CA SB No. 244523)
BERGER & HIPSKIND LLP
9538 Brighton Way, Ste. 320
Beverly Hills, CA 90210
Telephone: 323-886-3430
Facsimile: 323-978-5508
E-mail: dsb@bergerhipskind.com
E-mail: dph@bergerhipskind.com
E-Mail: eem@bergerhipskind.com

/s/ Stephen B. Brauerman
Stephen B. Brauerman (#4952)
Ronald P. Golden III (#6254)
600 N. King Street, Suite 400
P.O. Box 25130
Wilmington, Delaware 19801
(302) 655-5000
sbrauerman@bayardlaw.com
rgolden@bayardlaw.com

*Attorneys for Plaintiff NexGen
Control Systems, LLC*