

UNITED STATES DISTRICT COURT
FOR THE WESTERN DISTRICT OF TEXAS
WACO DIVISION

ACQIS LLC,
a Texas limited liability company,

Plaintiff,

v.

QUANTA COMPUTER, INC., a
Taiwanese corporation,

Defendant.

Civil Action No. 6:23-cv-00265

JURY TRIAL DEMANDED

COMPLAINT FOR PATENT INFRINGEMENT

Plaintiff ACQIS LLC (“Plaintiff” or “ACQIS”), by its attorneys, hereby alleges patent infringement against Defendant Quanta Computer, Inc. (“Defendant” or “Quanta”) as follows:

INTRODUCTION

1. This is an action for patent infringement under the United States Patent Laws, 35 U.S.C. § 1 *et seq.* Beginning in the late 1990s, Dr. William Chu founded ACQIS and invented a variety of pioneering computer technologies that employed serial transmission along low voltage differential signal (LVDS) channels to dramatically increase the speed at which data can be transmitted while also reducing power consumption and noise. Dr. Chu’s inventions have become foundational in the computer industry, and are found in a variety of data transmission systems, including PCI Express (PCIe) and/or USB 3.x¹ transactions.

¹ As used herein, “USB 3.x” refers to USB 3.0 and subsequent versions, including USB 3.1, USB 3.2, and any other subsequent versions.

2. Quanta has infringed the following patents owned by ACQIS: U.S. Patent Nos. 9,529,768 (“768 patent”), 9,703,750 (“750 patent”), 8,756,359 (“359 patent”), 8,626,977 (“977 patent”), RE44,739 (“739 patent”), 8,977,797 (“797 patent”), 9,529,769 (“769 patent”), RE45,140 (“140 patent”), RE44,654 (“654 patent”), and 8,234,436 (“436 patent”) (collectively, the “ACQIS Patents”). Copies of the ACQIS Patents are attached to this Complaint as Exhibits 1-10.

3. Specifically, Quanta has directly infringed the ACQIS Patents through: (1) the manufacture, use, offering to sale, and/or sale in the United States, and/or the importation into the United States, of infringing computer products; (2) the practice of claimed methods of the ACQIS Patents by manufacturing, using and/or testing computer products in the United States; and (3) the importation into the United States of computer products made abroad using ACQIS’s patented processes.

4. ACQIS seeks damages Defendant’s infringement of the ACQIS Patents. ACQIS is entitled to past damages because, without limitation, it has provided actual notice to Defendant and for method claims which do not require marking.

THE PARTIES AND RELATED ENTITIES

5. Plaintiff ACQIS LLC, is a limited liability company organized and existing under the laws of the State of Texas, with offices at 411 Interchange Street, McKinney, Texas 75071. A related entity, ACQIS Technology, Inc., is a corporation organized under the laws of the State of Delaware, having its principal place of business at 1503 Grant Road, Suite 100, Mountain View, California 94040. ACQIS LLC is operated from California, where its President, Dr. William Chu, resides. Dr. Chu is also the Chief Executive Officer of ACQIS Technology, Inc.

6. Quanta Computer, Inc. (“Quanta”) is a Taiwanese company with its principal place of business at No. 211 Wenhua 2nd Rd., Guishan Dist., Taoyuan City 333, Taiwan, R.O.C.² Quanta has sold infringing laptops, desktop computers, and servers to related Quanta entities and to third parties in the United States, and has shipped infringing laptops, desktop computers, and servers to the United States.

7. Quanta is the parent company of a multinational conglomerate that operates under the name “Quanta” or “Quanta Computer.”³ According to its website, “Quanta is a one [*sic*] of the Global Fortune 500 Companies and also one of the world’s leading notebook manufacturers” with “production and service locations [] across Asia, North America, Latin America, Europe and South East Asia.”⁴ Quanta’s website claims that “[i]n order to maximize the effectiveness of mass production with *centralized management* and just-in-time distribution, we have established regional manufacturing sites and maintenance locations in Taiwan, *the U.S.*, and Europe to complete the *top-down integration* and gradually accelerate the adoption of automation and smart manufacturing in our production sites.”⁵

8. Quanta’s website contains a map of its locations, titled “Global Major Operating Sites”⁶:

² Quanta website, About Quanta – Major Operating Sites, <https://www.quantatw.com/Quanta/english/about/serviceinfo.aspx>.

³ Quanta website, About Quanta – Company Profile, <https://www.quantatw.com/Quanta/english/about/company.aspx>.

⁴ Quanta website, About Quanta – Company Profile, <https://www.quantatw.com/Quanta/english/about/company.aspx>.

⁵ Quanta website, About Quanta – Company Profile, <https://www.quantatw.com/Quanta/english/about/company.aspx> (emphasis added).

⁶ Quanta website, About Quanta – Global Major Operating Sites, <https://www.quantatw.com/Quanta/english/about/serviceinfo.aspx>



9. Quanta International Limited (“QIL”) is a Cayman Islands holding company Reg. No. 83454, and is a wholly-owned subsidiary of Quanta.⁷

10. Quanta Cloud Technology USA LLC (“QCT-USA”) is a California limited liability corporation based in San Jose, California and is a wholly-owned subsidiary of QIL.⁸ QCT-USA

⁷ Quanta 2022 Q3 Report at 9-10.

⁸ Quanta 2022 Q3 Report at 10; *Press Release: QCT Now Offering AMD EPYC™ 7002 Series Processors*, Aug. 8, 2019.

engages in “sale of computer peripherals” including, upon information and belief, sales of accused servers to customers in the United States.⁹

11. QCT-USA purchases its product directly from the Defendant, its ultimate parent company. For example, in the first nine months of 2022, QCT-USA made purchases totaling \$73.8 million USD from Quanta, amounting for 100% of QCT-USA’s purchases from related entities.¹⁰

12. QCT-USA’s revenue is rolled up to, and included in the financials of, its parent company Quanta.¹¹ Quanta derives substantial revenue and profit from QCT-USA’s activities.

13. Quanta directs shipments to QCT-USA including, upon information and belief, imports of accused products. For example, on April 24, 2018, Quanta shipped to QCT-USA sixty-one pallets of servers, containing 451 cartons and weighing over 30,000 pounds.¹²

14. Access International Company (“AIC”) is a Wyoming holding company, and is a wholly-owned subsidiary of QIL.¹³ AIC owns 100% of the shares of four entities.

15. Two of AIC’s wholly-owned subsidiaries—Quanta Computer USA, Inc. (“QCA”), and Quanta Service Incorporation (“QSI-USA”)—are California corporations based in Fremont, California and engage in “[a]fter-sales service of computers and peripherals.”¹⁴ QCA owns 100% of the shares of Quanta Computer Nashville, LLC, and QSI-USA owns 100% of the shares of Quanta Service Nashville LLC. The revenues of these four entities are rolled up to, and

⁹ Quanta 2022 Q3 Report at 10.

¹⁰ Quanta 2022 Q3 Report at 61 (2,237,253,000 new Taiwanese dollars, converted using exchange rate 1:0.033).

¹¹ *See, e.g.*, Quanta 2022 Q3 Report.

¹² Bill of Lading No. YESLYESU124407 (described as “61PALLET5451CARTONS SVR S2B10G(AST,SASEXP;WOC-R-H2P SU1U2.5 STORAGE JB7T WOHHDD(DUAL,W-2.5TRAY)500W SERVER S5B 3.5 2.3G 2 16G 8 4T 2 960G”).

¹³ Quanta 2022 Q3 Report at 10.

¹⁴ Quanta 2022 Q3 Report at 10; California Secretary of State Business Records Search.

included in the financials of, their ultimate parent company Quanta.¹⁵ Quanta derives substantial revenue and profit from their activities.

16. Quanta Manufacturing Inc. (“QMI”) is another wholly-owned subsidiary of AIC and is a California corporation located in Fremont, CA. QMI owns 100% of the shares of Quanta Manufacturing Nashville, LLC (“QMN”), a limited liability corporation organized under the laws of California and based in LaVergne, Tennessee. Both QMI and QMN engage in “assembly and processing of computers and peripherals.”¹⁶ The revenues of QMI and QMN are rolled up to, and included in the financials of, their ultimate parent company Quanta.¹⁷ Quanta derives substantial revenue and profit from the activities of QMI and QMN.

17. QCH, Inc. (“QCH”), a Nevada corporation, is a wholly-owned subsidiary of AIC, and is engaged in “[s]ale of computer and peripherals.”¹⁸ Based on Quanta’s 2022 Q3 Report, the “transaction amount of business” between Quanta and QCH was approximately \$7.4 billion USD for the first nine months of 2022.¹⁹ For that same period, Quanta engaged in sales of approximately \$7 billion USD to QCH, amounting to 41.39% of Quanta’s total sales to related parties.²⁰

18. QCH owns 100% of the shares of QCH Nashville LLC (“QCHN”), a limited liability company based in LaVergne, Tennessee, and engaged in the “sale of computers and peripherals.”

¹⁵ See, e.g., Quanta 2022 Q3 Report.

¹⁶ Quanta 2022 Q3 Report at 10; California Secretary of State Business Records Search.

¹⁷ See, e.g., Quanta 2022 Q3 Report.

¹⁸ QCI and Subsidiaries 2022 Q3 Report at 10 (“Quanta 2022 Q3 Report”), available at https://www.quantatw.com/Quanta/english/investment/financials_qr3.aspx.

¹⁹ Quanta 2022 Q3 Report at 55 (226,683,283,000 new Taiwanese dollars, converted using exchange rate 1:0.033).

²⁰ Quanta 2022 Q3 Report at 61 (215,111,660,000 new Taiwanese dollars, converted using exchange rate 1:0.033).

19. QCH is a major consignee of record for Quanta imports. Some Quanta imports are addressed to QCH at the Fremont address for QMI, and other imports are addressed to QCH at the LaVergne address for QMN and QCHN.²¹

20. Quanta shares common control and a close relationship with the related entities identified above. As described in Quanta's 2021 annual report:

- a. Quanta Chairman Barry Lam is also the Chairman of AIC and QCH, and is a Director of QIL and QSI-USA.²² Mr. Lam is also the sole named representative for QIL, as a "QCI [Quanta] Representative."²³ Mr. Lam is one of three named representatives of AIC, as a "QIL Representative," and one of three named representatives of QCH, QMI and QCA, as an "AIC Representative."²⁴
- b. Quanta President and Vice-Chairman C.C. Leung is also President and Director of QCH, and is a Director of AIC, QMI, QSI-USA and QCA.²⁵ Mr. Leung is also Chairman of QSN, QCN, QCHN.
- c. Janice Lam is listed as Director and President of AIC, QMI, QSI-USA, QCA, and is a director of QCH.
- d. According to the Nevada Secretary of State business registrations, C.C. Leung (at a Taiwan address) is the President of QCH and Pak-Lee (aka Barry) Lam (at a Taiwan address) is a Director of QCH.

²¹ See, e.g., Bills of Lading Nos. YESLYESU127015 and DFDSTPE0193241.

²² Quanta 2021 Annual Report at 12, 161.

²³ Quanta 2021 Annual Report at 162.

²⁴ Quanta 2021 Annual Report at 162.

²⁵ Quanta 2021 Annual Report at 162.

21. Quanta has shipped infringing laptops, desktop computers, and servers to the United States to QCH, other Quanta entities and third parties.

22. For example, based on public information, on June 18, 2018, Quanta made four shipments totaling over 61,000 pounds, labeled “PC, Desktop with Flat Panel.”²⁶ Upon information and belief, these shipments included infringing desktop computers.

23. For example, based on public information, on June 27, 2018, Quanta made twelve shipments totaling over 447,000 pounds, the shipment labeled “Laptop Computer.”²⁷ Upon information and belief, these shipments included infringing laptop computers.

24. For example, based upon public records, in November and December 2018, Quanta sent three shipments, weighing over 27,000 pounds, to US-based QCH identifying the imported products as “SERVER S2VR W/CPU 2.4G2, DDR4 BPL” and marked “Made in Taiwan.”²⁸ Upon information and belief, these shipments included infringing servers.

JURISDICTION AND VENUE

25. This is an action for patent infringement under the United States patent laws, 35 U.S.C. § 101 *et seq.*

26. This Court has subject matter jurisdiction pursuant to 28 U.S.C. §§ 1331 and 1338(a).

27. This Court has personal jurisdiction over the Defendant consistent with the requirements of the Due Process Clause of the United States Constitution and the Texas Long Arm Statute.

²⁶ U.S. Import Bills of Lading Nos. SHKK156781956878, SHKK156781956694, SHKK156781956908, and SHKK156781956878.

²⁷ U.S. Import Bills of Lading Nos. SHKK156781751077, SHKK156781750971, SHKK156781751329, SHKK156781751138, SHKK156781752449, SHKK156781751565, SHKK156781751428, SHKK156781752784, SHKK156781752272, SHKK156781752630, SHKK156781751961, SHKK156781751800.

²⁸ U.S. Import Bills of Lading Nos. DFDSTPE0191643, DFDSTPE0190667, DFDSTPE0189681.

28. On information and belief, Quanta has purposefully manufactured and/or distributed computer products that infringe the ACQIS Patents, or that were made abroad using patented processes claimed in the ACQIS Patents, through established distribution channels with the expectation that those products would be sold in the United States, State of Texas, and in this District.

29. Publicly available import data indicates that Quanta sells and imports servers and computers into the United States. Data from Import Genius indicates that, in the past five years, Quanta has acted as supplier for 3,158 shipments imported into the United States, totaling over 2,880 containers and over 27 million kg.²⁹ Nearly half of those shipments—in both number (1,512) and volume (1,340 containers)—were sent to QCH, totaling over 16 million kg.

30. Publicly available import data indicates that Quanta has sold imported products to purchasers in this judicial district. In the past five years, Quanta has supplied and imported 125 shipments, totaling 48 containers and over 250,000 kg, to purchasers in El Paso, Texas.

31. Upon information and belief, some of these imports relate to accused products. For example, based on public information, on August 22, 2018, Quanta made a shipment weighing over 2,300 pounds to a consignee based in El Paso, Texas, described as “SERVER INCLUDING MOTHERBOARD F20 MB M.2 WCPU1.8 256X1 32X2 TPM FAB SP.”³⁰ Upon information and belief, this shipment included infringing servers.

32. Further, Defendant has (itself and/or through the activities of subsidiaries, affiliates, or intermediaries) committed acts of patent infringement in the United States, State of Texas and this District, including by making, using, offering to sell, and/or selling infringing computer products in the United States, State of Texas and this District; importing infringing computer products

²⁹ U.S. Import Records, available from Import Genius.

³⁰ U.S. Import Bills of Lading No. NAQAALAX8411429V.

and/or computer products made abroad using ACQIS's patented processes into the United States for sale in the State of Texas and this District.

33. Defendant Quanta is the parent corporation for a production and distribution chain (together with other Quanta subsidiaries, affiliates, and intermediaries) with respect to the manufacture, use, offering to sell, and/or sale of infringing computer products and with respect to the importation into the United States of infringing computer products and of computer products made abroad using patented processes claimed in the ACQIS Patents.

34. Defendant Quanta shares common control and a close relationship with QCH. As described in Quanta's 2021 annual report:

- (a) Quanta Chairman Barry Lam is also the Chairman of QCH and AIC, and is a Director of QIL and QSI-USA.³¹ Mr. Lam is also the sole named representative for QIL, as a "QCI [Quanta] Representative."³² Mr. Lam is one of three named representatives of AIC, as a "QIL Representative," and one of three named representatives of QCH, as an "AIC Representative."³³
- (b) Quanta President and Vice-Chairman C.C. Leung is also President and Director of QCH, and is a Director of AIC.³⁴ Mr. Leung is one of three named representatives of AIC, as a "QIL Representative," and one of three named representatives of QCH, as an "AIC Representative."³⁵
- (c) According to the Nevada Secretary of State business registrations, C.C. Leung (at a Taiwan address) is the President of QCH and Pak-Lee (aka Barry) Lam (at a

³¹ QCI and Subsidiaries 2021 Annual Report at pp. 12, 161 ("Quanta 2021 Report"), available at <https://www.quantatw.com/Quanta/english/investment/annualreports.aspx>.

³² Quanta 2021 Report at 162.

³³ Quanta 2021 Report at 162.

³⁴ Quanta 2021 Report at 12.

³⁵ Quanta 2021 Report at 162.

Taiwan address) is a Director of QCH.

(d) As of September 30, 2022, QCH had a financing balance of approximately \$2.6 billion USD to Quanta and a maximum fund financing limit of nearly \$5.4 billion USD.³⁶

(e) From January 9, 2022 to January 9, 2023, Quanta shipped 901 cartons of servers (including one shipment of servers and parts) in 5 shipments to QCI-USA, but marked with QCH's name.

35. Accordingly, Quanta has established minimum contacts within Texas and purposefully availed itself of the benefits of Texas, and the exercise of personal jurisdiction over Quanta would not offend traditional notions of fair play and substantial justice. In addition, or in the alternative, this Court has personal jurisdiction over Quanta pursuant to Federal Rule of Civil Procedure 4(k)(2). *See, e.g., ACQIS LLC v. Lenovo Group Ltd. et al.*, 572 F. Supp. 3d 291, 302-307 (W.D. Tex. Nov. 16, 2021) (denying motion to dismiss for lack of personal jurisdiction as to served defendants).

36. Venue is proper in this District pursuant to 28 U.S.C. § 1391(c)(3) because Defendants do not reside in the United States and thus may be sued in any judicial district in the United States pursuant to 28 U.S.C. § 1391(c)(3).

37. Venue is also appropriate because the patents asserted in this case have been previously asserted in cases before this Court. *See ACQIS LLC v. MiTac Computing Tech. Corp.*, No. W-20-cv-00962-ADA, 2021 U.S. Dist. LEXIS 197938, 2021 WL 4805431 (W.D. Tex., Oct. 14, 2021) (describing four pending cases and denying motion to transfer venue).

FACTUAL BACKGROUND

³⁶ Quanta 2022 Q3 Report at 55 (approximately 79.4 billion new Taiwanese dollars and approximately 164 billion new Taiwanese dollars, converted using exchange rate 1:0.033).

Dr. Chu and the ACOIS Patents

38. Dr. William Chu has been a prolific innovator in the computing industry since the 1970s.

39. In 1976, Dr. Chu received his Ph.D. in Electrical Engineering from the University of California, Berkeley. Dr. Chu then began working in semiconductor design for American Microsystems, Inc. from 1976 to 1977, and then for Zilog, Inc. from 1977 to 1982.

40. In 1982, Dr. Chu founded Verticom, Inc., which developed innovative technologies relating to video transmission over telephone lines. Verticom also developed graphics products for the PC computer-aided design (CAD) market. Verticom's success resulted in its stock being listed on the NASDAQ exchange in 1987. In 1988, Verticom was acquired by Western Digital Imaging, Inc.

41. Dr. Chu served as Vice President of Engineering for Western Digital from 1988 to 1991, overseeing a development team in the desktop and portable graphics chip division. In the course of his work at Western Digital, Dr. Chu in 1988 started the company's portable graphics chip business, which became #1 in the portable graphics chip market by 1991. Dr. Chu also led Western Digital to achieve the #1 market share in the PC graphics market in 1990.

42. After Western Digital, Dr. Chu worked for Acumos, Inc. from 1991 to 1992 as a Vice President managing engineering for computer graphics chip development. Acumos was acquired by Cirrus Logic, Inc. in 1992.

43. Dr. Chu then worked for Cirrus Logic from 1992 to 1997, first as a General Manager in the Desktop Graphics Division and later as Co-President of the Graphics Chip Business Unit. During Dr. Chu's time at Cirrus Logic, the company achieved #1 market share in the PC graphics chip market.

44. In 1998, Dr. Chu founded ACQIS Technology, Inc. to pursue his vision of developing a small, portable computer module that could be interchangeably connected with a variety of different peripheral consoles. In the course of this development effort, Dr. Chu recognized the need for a better interconnection between the core computing module and a peripheral console. Such interconnections traditionally conveyed peripheral component interconnect (PCI) bus transactions in parallel using a large number of signal channels and connector pins. This made it difficult to employ LVDS channels, which are more "cable friendly," consume less power, and generate less noise. Dr. Chu wanted to develop an interconnection system that was scalable, used connectors with low pin counts, was power-efficient, high performing, and easily extendible for future computing needs and technologies. This development work resulted in a large family of patents now owned by ACQIS, which disclose and claim a variety of pioneering inventions relating to improved, high-performance and low-power consuming interconnection technologies for computer modules.

45. After several decades in the industry, Dr. Chu is now a named inventor of over forty U.S. Patents.

46. Among the patent portfolio covering Dr. Chu's inventions and owned by ACQIS are the ACQIS Patents asserted in this case.

47. The '768 patent, entitled "Computer System Including CPU or Peripheral Bridge Directly Connected to a Low Voltage Differential Signal Channel that Communicates Serial Bits of a Peripheral Component Interconnect Bus Transaction in Opposite Directions," was duly and legally issued on December 27, 2016, from a patent application filed March 13, 2014, with William W.Y. Chu as the sole named inventor. The '768 patent claims priority to U.S. Provisional Patent Application No. 60/134,122, filed on May 14, 1999.

48. The '750 patent, entitled "Computer System Including CPU or Peripheral Bridge Directly Connected to a Low Voltage Differential Signal Channel that Communicates Serial Bits of a Peripheral Component Interconnect Bus Transaction in Opposite Directions," was duly and legally issued on July 11, 2017, from a patent application filed October 9, 2014, with William W.Y. Chu as the sole named inventor. The '750 patent claims priority to U.S. Provisional Patent Application No. 60/134,122, filed on May 14, 1999.

49. The '359 patent, entitled "Computer System Including CPU or Peripheral Bridge to Communicate Serial Bits of Peripheral Component Interconnect Bus Transaction and Low Voltage Differential Signal Channel to Convey the Serial Bits," was duly and legally issued on June 17, 2014, from a patent application filed January 17, 2013, with William W.Y. Chu as the sole named inventor. The '359 patent claims priority to U.S. Provisional Patent Application No. 60/134,122, filed on May 14, 1999.

50. The '977 patent, entitled "Computer System Including CPU or Peripheral Bridge to Communicate Serial Bits of Peripheral Component Interconnect Bus Transaction and Low Voltage Differential Signal Channel to Convey the Serial Bits," was duly and legally issued on

January 7, 2014, from a patent application filed July 27, 2012, with William W.Y. Chu as the sole named inventor. The '977 patent claims priority to U.S. Provisional Patent Application No. 60/134,122, filed on May 14, 1999.

51. The '739 patent, entitled "Data Security Method and Device for Computer Modules," was duly and legally issued on January 28, 2014, from a patent application filed May 21, 2013, with William W.Y. Chu as the sole named inventor. The '739 patent claims priority to U.S. Patent Application No. 11/056,604, filed on February 10, 2005.

52. The '797 patent, entitled "Method of Improving Peripheral Component Interface Communications Utilizing a Low Voltage Differential Signal Channel," was duly and legally issued on March 10, 2015, from a patent application filed October 10, 2012, with William W.Y. Chu as the sole named inventor. The '797 patent claims priority to U.S. Provisional Patent Application No. 60/134,122, filed on May 14, 1999.

53. The '769 patent, entitled "Computer System Including CPU or Peripheral Bridge Directly Connected to a Low Voltage Differential Signal Channel that Communicates Serial Bits of a Peripheral Component Interconnect Bus Transaction In Opposite Directions," was duly and legally issued on December 27, 2016, from a patent application filed February 26, 2016, with William W.Y. Chu as the sole named inventor. The '769 patent claims priority to U.S. Patent Application No. 11/097,694, filed on March 31, 2005.

54. The '140 patent, entitled "Data Security Method and Device for Computer Modules," was duly and legally issued on September 16, 2014, from a reissue application filed December 17, 2013, with William W.Y. Chu as the sole named inventor. The '140 patent is a reissue of U.S. Patent No. 6,643,777, which issued on November 4, 2003, from a patent application filed May 14,

1999. The '140 patent claims priority to U.S. Patent Application No. 09/312,199, filed on May 14, 1999.

55. The '654 patent, entitled "Data Security Method and Device for Computer Modules," was duly and legally issued on December 17, 2013, from a reissue application filed October 10, 2012, with William W.Y. Chu as the sole named inventor. The '654 patent is a reissue of U.S. Patent No. 6,643,777, which issued on November 4, 2003, from a patent application filed May 14, 1999. The '654 patent claims priority to U.S. Patent Application No. 09/312,199, filed on May 14, 1999.

56. The '436 patent, entitled "Computer System Including Peripheral Bridge to Communicate Serial Bits of Peripheral Component Interconnect Bus Transaction and Low Voltage Differential Signal Channel to Convey the Serial Bits," was duly and legally issued on July 31, 2012, from a continuation of application No. 12/504,534, filed on Jul. 16, 2009, with William W.Y. Chu as the sole named inventor. The '797 patent claims priority to U.S. Provisional Patent Application No. 60/134,122, filed on May 14, 1999.

57. The inventions claimed in the ACQIS Patents enable computers to operate faster with better efficiency through faster interconnections including between the core computing power modules and any connected consoles.

58. The claims in the ACQIS Patents generally relate to computers and computer systems that employ CPUs coupled to LVDS channels that convey various types of data (*e.g.*, PCI bus transactions, USB 3.x data, and/or digital video data) in a serial bit stream using pairs of unidirectional channels to convey the data in opposite directions.

59. Over the years, Dr. Chu's inventive developments have become more and more widely used in computing technologies. One prime example is the computing industry's adoption of PCI

Express, which post-dates Dr. Chu’s inventions but embodies Dr. Chu’s patented interconnection invention by using “high speed, low voltage, differential serial pathway for two devices ... to communicate simultaneously by implementing dual unidirectional paths between two devices[.]”

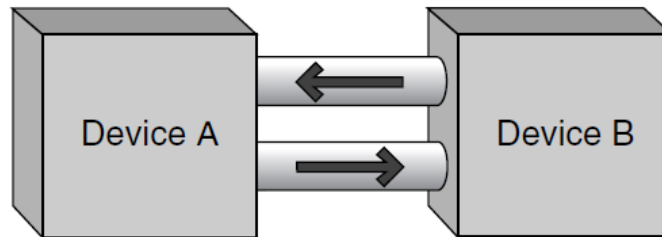

See *Introduction to PCI Express – A Hardware and Software Developers Guide*, Intel Press (2003), at 1-2 (“There are certain times in the evolution of technology that serve as inflection points that forever change the course of events. For the computing sector and communications, the adoption of PCI Express, a groundbreaking new general input/output architecture, will serve as one of these inflection points.”).

60. PCI Express connections transmit data packets known as transaction layer packets (TLP) that include data bits, address bits, and byte enable (BE) information bits.

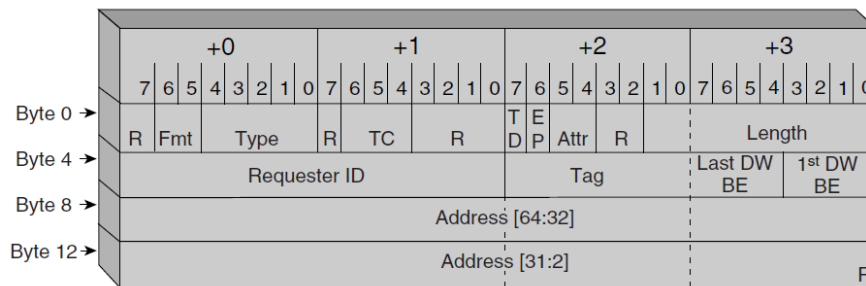

Id. at 93-114.

61. PCI Express “establishes a unique divergence from historical PCI evolutions through a layered architecture improving serviceability and scalability as well as easing software

transitions through backward compatibility.”³⁷ The compatibility of PCI Express with PCI can be further explained as follows: “PCI Express employs the same usage model and load-store communication model as PCI and PCI-X. It supports familiar transactions such as memory read/write, IO read/write and configuration read/write transactions. The memory, IO, and configuration address space model is the same as PCI and PCI-X address spaces. By maintaining the address space model, existing OS and driver software will run in a PCI Express system without any modifications. In other words, PCI Express is software backward compatible with PCI and PCI-X systems. In fact a PCI Express system will boot an existing OS with no changes to current drivers and application programs. Even PCI/ACPI power management software will still run.”³⁸

62. In sum, PCI Express connections are LVDS channels that convey data bits, address bits, and byte enable information bits of a PCI bus transaction in a serial bit stream using pairs of unidirectional, differential signal lanes to convey the information in opposite directions allowing the connection to be scalable and dramatically reducing the pin-count required for connectors, as well as other benefits. “Currently PCI Express defines the following configuration of serial links: x1, x2, x4, x8, x12, x16, and x32. ... An x2 configuration indicates two serial paths to and from a device[.]”

³⁷ Adam H. Wilen, Justin P. Schade, Ron Thornburg. INTRODUCTION TO PCI EXPRESS - A HARDWARE AND SOFTWARE DEVELOPER’S GUIDE, Intel Press, 2003, pages 51-52.

³⁸ Ravi Budruk, et al., PCI EXPRESS SYSTEM ARCHITECTURE, 400, (MindShare Inc., 2004) at 11.

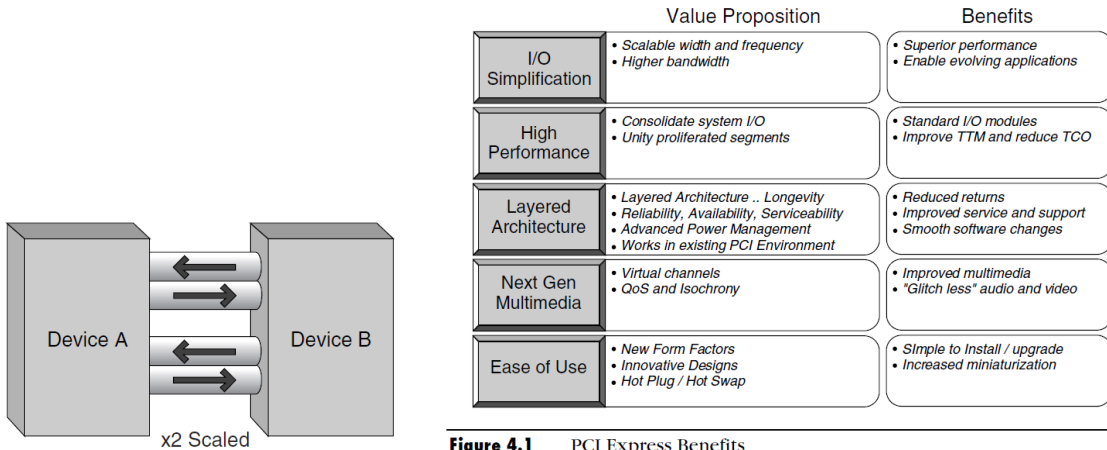

Figure 4.1 PCI Express Benefits

Id. at 3, 50.

63. Another example of a computer-to-peripheral interconnection that embodies Dr. Chu’s patented invention is the USB 3.x connection. The “Super Speed” USB 3.0 architecture uses at least two pairs of unidirectional, point-to-point differential signal paths. Each pair includes a transmit path and a receiving path, thus transmitting the USB data packet information in opposite directions.

3.1.4 USB 3.0 Architecture Summary

USB 3.0 is a dual-bus architecture that incorporates USB 2.0 and a SuperSpeed bus. Table 3-1 summarizes the key architectural differences between SuperSpeed USB and USB 2.0.

Table 3-1. Comparing SuperSpeed to USB 2.0

Characteristic	SuperSpeed USB	USB 2.0
Data Rate	SuperSpeed (5.0 Gbps)	low-speed (1.5 Mbps), full-speed (12 Mbps), and high-speed (480 Mbps)
Data Interface	Dual-simplex, four-wire differential signaling separate from USB 2.0 signaling Simultaneous bi-directional data flows	Half-duplex two-wire differential signaling Unidirectional data flow with negotiated directional bus transitions
Cable signal count	Six: Four for SuperSpeed data path Two for non-SuperSpeed data path	Two: Two for low-speed/full-speed/high-speed data path
Bus transaction protocol	Host directed, asynchronous traffic flow Packet traffic is explicitly routed	Host directed, polled traffic flow Packet traffic is broadcast to all devices.

Universal Serial Bus 3.0 Specification, Rev. 1.0 (Nov. 12, 2008), at 3.1 to 3.5. USB 3.x ports operate in conformance with all USB protocols, including USB 2.0 protocols and USB 3.0 or later protocols, which are backward compatible with the USB 2.0 protocol. In sum, USB 3.x connections are LVDS channels using two unidirectional, differential signal pairs that transmit USB protocol data packets in opposite directions.

64. The Direct Media Interface (“DMI”) is similar to PCIe and implements at least four serial lanes that all use differential signaling constituting 2 transmit lanes and 2 receive lanes and, therefore, transmitting data in opposite directions. See <https://www.intel.com/content/dam/www/public/us/en/documents/white-papers/ia-introduction-basics-paper.pdf>; see also https://en.wikipedia.org/wiki/Direct_Media_Interface (“DMI shares many characteristics with PCI Express, using multiple lanes and differential signaling to form a point-to-point link.”).

65. The On-Package Interface (OPI) is like DMI but is used when a CPU and system controller are integrated into a single system-on-a-chip (“SoC”). See, e.g., <https://web.archive.org/web/20170106002415/https://www.anandtech.com/show/10959/intel-launches-7th-generation-kaby-lake-i7-7700k-i5-7600k-i3-7350k/5>.

66. Additional interfaces that employ LVDS channels include, but are not limited to, DisplayPort³⁹, Embedded DisplayPort (“eDP”)⁴⁰, Serial-Attached SCSI (“SAS”)⁴¹, and Serial ATA or Serial AT Attachment (“SATA”)⁴². Other protocols that use LVDS channels are USB4, Thunderbolt 3, and Thunderbolt 4. Since USB4, Thunderbolt 3, and Thunderbolt 4 use USB-Type

³⁹ Tektonix, THE BASICS OF SERIAL DATA COMPLIANCE AND VALIDATION MEASUREMENTS – PRIMER, page 9.

⁴⁰ eDP is a display panel interface standard that defines the signaling interface between CPUs/GPUs and integrated displays. It is based on the existing DisplayPort standard. Essentially, it is an embedded version of the DisplayPort standard oriented toward applications, such as notebooks and All-In-One PCs. Like DisplayPort, it consists of the Main Link, Auxiliary channel, and an optional Hot-Plug Detect signal. See <https://edc.intel.com/content/www/us/en/design/ipla/software-development-platforms/client/platforms/alder-lake-desktop/12th-generation-intel-core-processors-datasheet-volume-1-of-2/003/embedded-displayport-edp/>.

⁴¹ HP. *Serial ATA and Serial Attached SCSI technologies*. TECHNOLOGY BRIEF, 2003, page 5. Available at <http://h10032.www1.hp.com/ctg/Manual/c00256909.pdf>.

⁴² HP. *Serial ATA and Serial Attached SCSI technologies*. TECHNOLOGY BRIEF, 2003, page 5. Available at <http://h10032.www1.hp.com/ctg/Manual/c00256909.pdf>; Tektonix, THE BASICS OF SERIAL DATA COMPLIANCE AND VALIDATION MEASUREMENTS – PRIMER, page 9.

C connectors, at least two low voltage differential signaling pairs in opposite directions are used to transfer PCI Express, DisplayPort, and/or USB packets.⁴³ Moreover, Thunderbolt controllers use PCI Express.⁴⁴ USB4 offers display, data, and load/store functionality over a single USB Type-C connector and retains compatibility with the existing ecosystem of USB and Thunderbolt products.⁴⁵ USB4 (formerly known as Thunderbolt 3 protocol) can tunnel USB 3/x, PCIe, and DisplayPort protocols. It uses up to two lanes, each consisting of two differential signal pairs (Tx/Rx), and is used for tunneled protocol and control traffic.⁴⁶

67. The physical layer of PCI Express includes PLL circuitry. *See* PCI Express Base Specification Revision 3.0, Section 1.5.3, page 49 (physical Layer “includes all circuitry for interface operation, including driver and input buffers, parallel-to-serial and serial-to-parallel conversion, PLL(s), impedance matching circuitry” as well as “logical functions related to interface initialization and maintenance”). The figure below also shows the use of PLL circuitry:

⁴³ Brad Saunders. USB Type-C System Overview: Enabling connections for data, display, and power. USB Developer Days 2019 – Taipei, Taiwan, November 19, 2019, pag3 7. Available at <https://www.usb.org/sites/default/files/D1T1-2%20-%20USB%20Type-C%20System%20Overview.pdf>.

⁴⁴ *See* Intel. Thunderbolt Technology: The Transformational PC I/O. Technology Brief, page 3. Available at <http://www.123seminaronly.com/Seminar-Reports/008/51703485-intel-thunderbolt-technology.pdf>.

See also Jeff Bake, Dinesh Jain, and Jacob Ontiveros. Thunderbolt™ 3 Technology and USB-C. Intel Developer Forum (IDF15), page 27. Available at <https://www.thunderbolttechnology.net/sites/default/files/Thunderbolt3USBC-IDFf.pdf>

⁴⁵ Universal Serial Bus 4 (USB4) Specification, Version 1.0, August 2019, page 1.

⁴⁶ <https://www.usb.org/sites/default/files/D1T1-3%20-%20USB4%20System%20Overview.pdf> at 14.

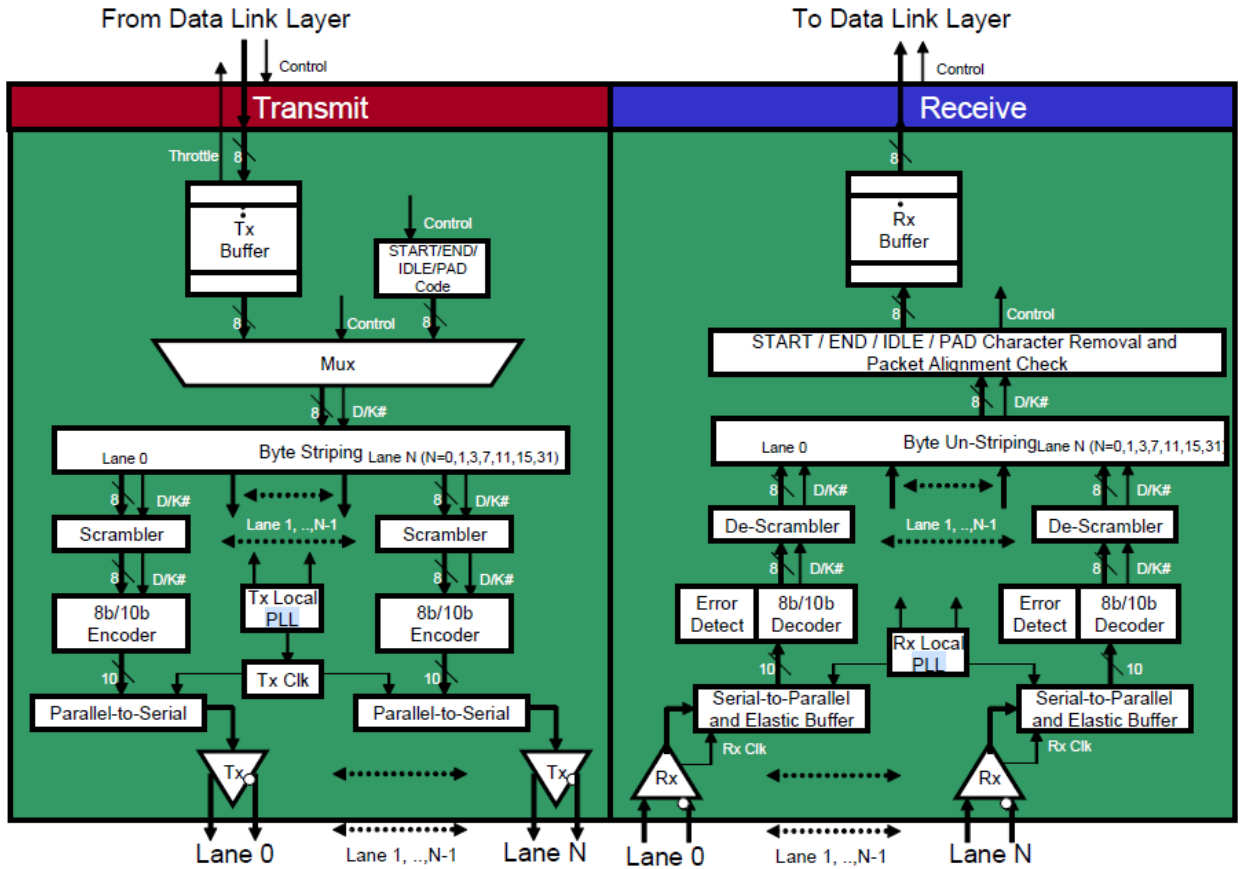

Ravi Budruk, *et al.*, PCI EXPRESS SYSTEM ARCHITECTURE, 454, (MindShare Inc., 2004), page 401.

68. Each claim of the ACQIS Patents is a patentable, valid and enforceable invention that is novel and non-obvious over the prior art.

69. ACQIS has not authorized or licensed Quanta to practice any of the inventions claimed in the ACQIS Patents.

Quanta’s Infringing Products

70. Quanta is a global leader in the personal and business computer market. Quanta makes and sells a variety of laptop computers, desktop computers, and computer servers. Quanta imports infringing laptop computers, desktop computers, and computer servers, as well as laptop computers, desktop computers, and computer servers made using infringing processes, into the

United States and into this judicial District, through established distribution channels with the expectation that those products would be sold in the United States, State of Texas and this District.

71. On information and belief, Quanta's sale of laptops, desktops, and servers generates billions of dollars in revenue every year. (ACQIS will seek further information regarding other potentially infringing Quanta products, like smartphones in this suit).

72. According to Quanta's website, notebook PCs are its "main product category and are mostly for export." Quanta sold 75.3 million notebook PCs in 2021, which it estimates is approximately 28% of the global market.⁴⁷

73. Exports to the U.S. comprise approximately half of Quanta's worldwide exports, "with the U.S. being the major exporting region."⁴⁸

74. Quanta has directly infringed one or more claims of each of the ACQIS Patents under at least 35 U.S.C. §§ 271(a) and (g), by making, using, offering to sell, and/or selling within the United States, and/or importing into the United States, computer products that embody the claimed inventions of Dr. Chu, and/or by importing into, and/or using, offering to sell, and/or selling in, the United States computer products that were made abroad using patented processes claimed in the ACQIS Patents.

75. Quanta makes, uses, imports, sells, and/or offers to sell a variety of laptop computer products in the United States that infringe one or more of the claims in the ACQIS Patents, and/or imports into, and/or using, offering to sell, and/or selling in, the United States laptop computer products that were made abroad using patented processes claimed in the ACQIS Patents including, without limitation, laptops sold under the brand names MacBook,

⁴⁷ Quanta 2021 Report at 109.

⁴⁸ Quanta 2021 Report at 109 (51.36% for FY2020, 48.05% for FY2021).

MacBook Air, and MacBook Pro. These products are collectively referred to as the “Accused Quanta Laptops.”

76. Quanta makes, uses, imports, sells, and/or offers to sell a variety of desktop computer products in the United States that infringe one or more of the claims in the ACQIS Patents, and/or imports into, and/or using, offering to sell, and/or selling in, the United States desktop computer products that were made abroad using patented processes claimed in the ACQIS Patents including, without limitation, desktop computers sold under the brand names iMac, iMac Pro, and Mac Mini. These products are collectively referred to as the “Accused Quanta Desktops.”

77. Quanta makes, uses, imports, sells, and/or offers to sell a variety of computer server products in the United States that infringe one or more of the claims in the ACQIS Patents, and/or imports into, and/or using, offering to sell, and/or selling in, the United States computer server products that were made abroad using patented processes claimed in the ACQIS Patents including, without limitation, edge and rack servers sold under the brand names QuantaGrid, QuantaPlex, STRATOS, QuantaEdge, Rackgo X, Rackgo M, F06A, and F06D. These products are collectively referred to as the “Accused Quanta Servers.”

78. The Accused Quanta Laptops, Accused Quanta Desktops, and Accused Quanta Servers are collectively referred to herein as the “Accused Quanta Products.”

79. On information and belief, Quanta manufactures and tests at least certain of the Accused Quanta Products abroad and uses, offers to sell, and/or sells such products in the United States, and/or imports such products into the United States.

80. On information and belief, at least certain of the Accused Quanta Products that Quanta imports into the United States are manufactured outside the United States using one or more processes claimed in the ACQIS Patents.

81. The Accused Quanta Products include products made, used, offered for sale, sold within the United States, and/or imported into the United States, at least since ACQIS provided Quanta actual notice of its infringement on or around May 14, 2018.

82. The Accused Quanta Products also include products made using the processes claimed in the ACQIS Patents and imported into the United States within the six years preceding the date of this Complaint.

83. The Accused Quanta Products also include products that are used to perform one or more methods claimed in the ACQIS Patents within the six years preceding the date of this Complaint.

The Accused Quanta Laptops

84. On information and belief, all of the Accused Quanta Laptops are configured and operate in substantially the same way as explained below using the product that Quanta manufactures that is ultimately known as the MacBook Pro (13-inch, 2017) as an example for illustrative purposes.

85. The MacBook Pro (13-inch, 2017) is a computer system that runs the macOS operating system.



https://web.archive.org/web/20170806220029/https://support.apple.com/kb/SP754?locale=en_US.

86. The MacBook Pro (13-inch, 2017) uses an Intel® Core processor, such as 2.3GHz dual-core Intel Core i5 processor, which is mounted on a motherboard.

Processor

- 2.3GHz dual-core Intel Core i5, Turbo Boost up to 3.6GHz, with 64MB of eDRAM
Configurable to 2.5GHz dual-core Intel Core i7, Turbo Boost up to 4.0GHz, with 64MB of eDRAM

https://web.archive.org/web/20170806220029/https://support.apple.com/kb/SP754?locale=en_US.

87. These processors are also known as the “Kaby Lake” family of processors, Intel’s 7th

Generation Intel® Core™ i5 Processors. See, e.g.,

https://everymac.com/systems/apple/macbook_pro/specs/macbook-pro-core-i5-2.3-13-mid-2017-retina-display-no-touch-bar-specs.html (identifying Intel’s 7th Generation “Kaby Lake”

2.3GHz Intel “Core i5” 7360U processors in this product);

[https://en.wikipedia.org/wiki/MacBook_Pro#Touch_Bar_\(2016%E2%80%932020\)](https://en.wikipedia.org/wiki/MacBook_Pro#Touch_Bar_(2016%E2%80%932020)) (identifying

“Kaby Lake” processor in this product);

<https://ark.intel.com/content/www/us/en/ark/products/97535/intel-core-i57360u-processor-4m-cache-up-to-3-60-ghz.html> (specifications for the Intel® Core™ i5-7360U processors, and identifying them as 7th Generation Intel® Core™ i5 Processors, products formerly known as “Kaby Lake”).

88. The 7th Generation Intel® Core™ i5-7360U processors integrate the central processing unit (CPU) with a graphics subsystem and an interface controller on a single chip. On information and belief, the Intel Core processors integrate one or more integrated interface controllers, such as to drive the PCIe channels connected to the processor.

Figure 1-1. KBL Y/U/U 4-Core and AML-Y22 Processor Line Platforms

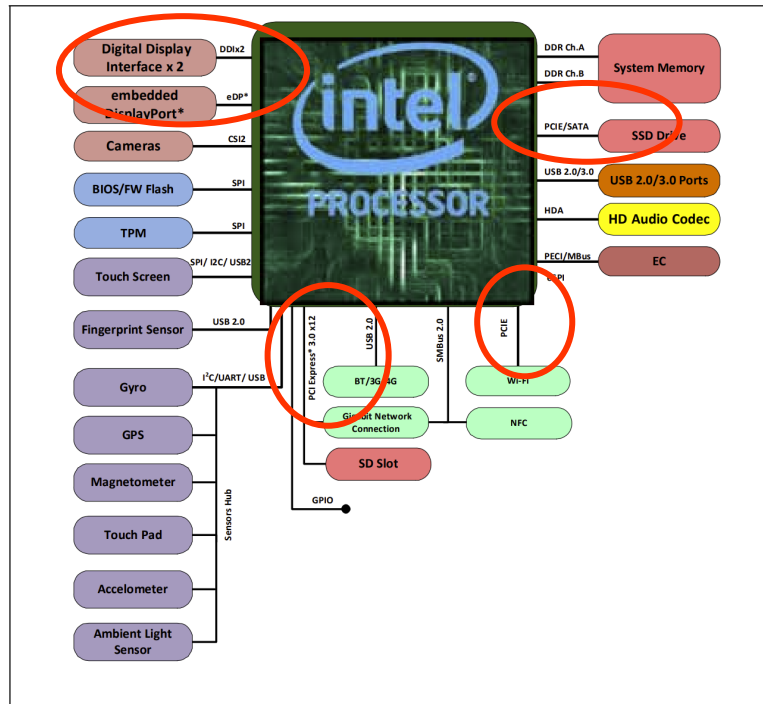

<https://www.intel.com/content/www/us/en/content-details/334661/7th-generation-intel-processor-families-for-u-y-platforms-datasheet-volume-1-of-2.html>, at 12; *see also id.* at 37.

Graphics

- Intel Iris Plus Graphics 640

https://web.archive.org/web/20170806220029/https://support.apple.com/kb/SP754?locale=en_US.

Processor Graphics	
Processor Graphics † ?	Intel® Iris® Plus Graphics 640
Graphics Base Frequency ?	300 MHz
Graphics Max Dynamic Frequency ?	1.00 GHz
Graphics Video Max Memory ?	32 GB
eDRAM ?	64 MB
Graphics Output ?	eDP/DP/HDMI/DVI

<https://ark.intel.com/content/www/us/en/ark/products/97535/intel-core-i57360u-processor-4m-cache-up-to-3-60-ghz.html>.

Expansion Options	
PCI Express Revision ?	3.0
PCI Express Configurations † ?	1x4, 2x2, 1x2+2x1 and 4x1
Max # of PCI Express Lanes ?	12

<https://ark.intel.com/content/www/us/en/ark/products/97535/intel-core-i57360u-processor-4m-cache-up-to-3-60-ghz.html>.

89. The MacBook Pro (13-inch, 2017) comprises a chassis or enclosure which houses one or more connectors that can couple to components of other computer systems and consoles, including the USB-C⁴⁹ ports.

⁴⁹ USB Type C connectors can convey both USB protocol data as well as DisplayPort digital video. See <https://www.usb.org/sites/default/files/D2T1-4%20-%20VESA%20DP%20Alt%20Mode%20over%20USB%20Type-C.pdf>; <https://www.displayport.org/displayport-over-usb-c-7-reasons/>; <https://www.androidauthority.com/what-is-usb-type-c-594575/>.



https://web.archive.org/web/20170806220029/https://support.apple.com/kb/SP754?locale=en_US.

Figure 1-1. KBL Y/U/U 4-Core and AML-Y22 Processor Line Platforms

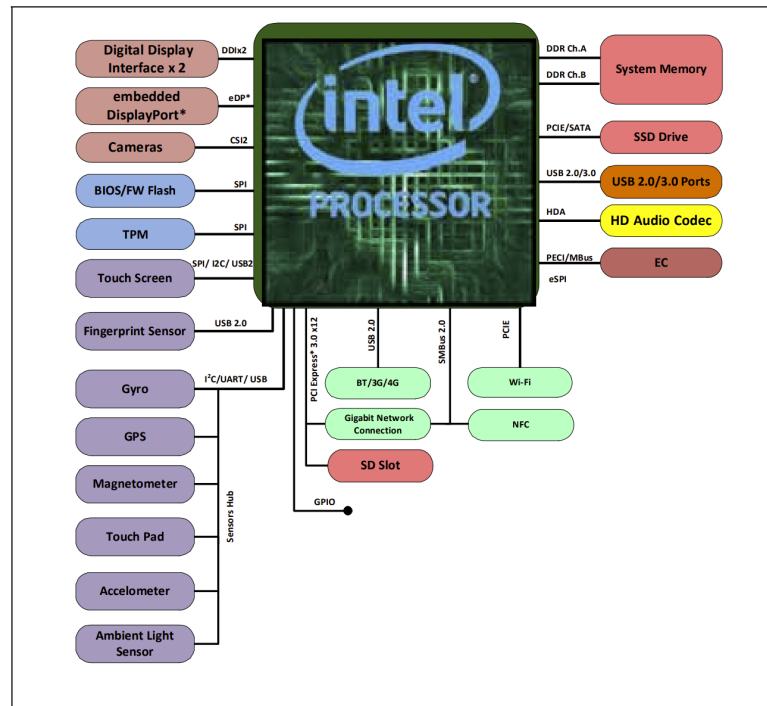

<https://www.intel.com/content/www/us/en/content-details/334661/7th-generation-intel-processor-families-for-u-y-platforms-datasheet-volume-1-of-2.html>, at 12; (identifying DDI, USB 3.x, and eDP channels extending from the SoC); *id.* at 34 (explaining that the DDI channels

can be configured as DisplayPort, HDMI, or DVI).

Charging and Expansion

Two Thunderbolt 3 (USB-C) ports with support for:

- Charging
- DisplayPort
- Thunderbolt (up to 40 Gbps)
- USB 3.1 Gen 2 (up to 10 Gbps)

Video Support

Simultaneously supports full native resolution on the built-in display at millions of colors and:

- One display with 5120-by-2880 resolution at 60Hz at over a billion colors
- Up to two displays with 4096-by-2304 resolution at 60Hz at millions of colors
- Up to two displays with 3840-by-2160 resolution at 60Hz at over a billion colors

Thunderbolt 3 digital video output

- Native DisplayPort output over USB-C
- VGA, HDMI, and Thunderbolt 2 output supported using adapters (sold separately)

https://web.archive.org/web/20170806220029/https://support.apple.com/kb/SP754?locale=en_US.

90. The Intel processors employed in the MacBook Pro (13-inch, 2017) connect directly to a variety of LVDS channels that convey data bits in a serial stream using unidirectional pairs of lanes transmitting data in opposite directions, including Intel's OPI⁵⁰ and PCIe channels, and the directly-connected PCIe channels connect the CPU to a mass storage device.

⁵⁰ When Intel connects the processor to a chipset on the same platform as a SoC, it connects these components via OPI interface. *See* https://en.wikichip.org/wiki/intel/microarchitectures/kaby_lake#Sockets.2FPlatform (disclosing OPI connection between dies on SoC of the Kaby Lake U series processors).

Figure 1-1. KBL Y/U/U 4-Core and AML-Y22 Processor Line Platforms

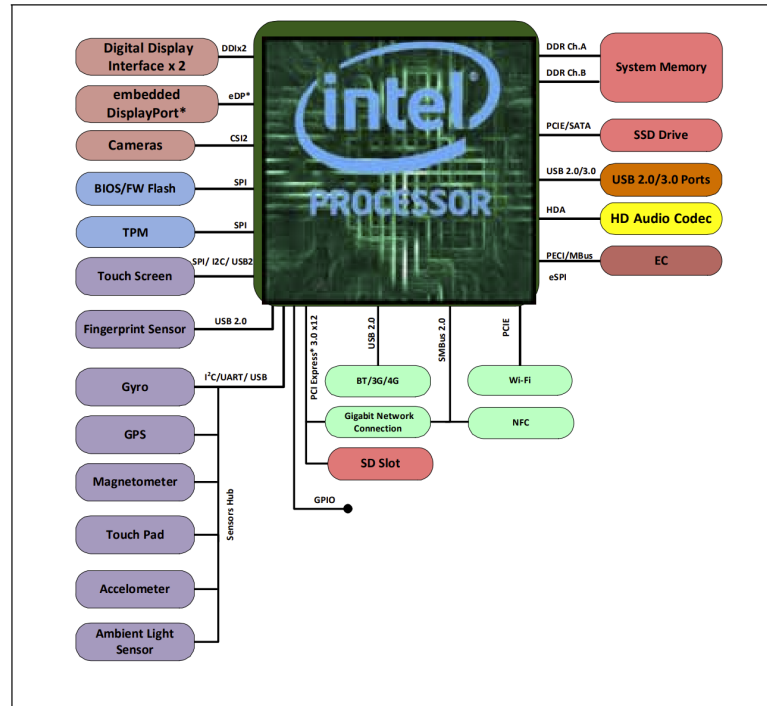

<https://www.intel.com/content/www/us/en/content-details/334661/7th-generation-intel-processor-families-for-u-y-platforms-datasheet-volume-1-of-2.html>, at 12.

91. The Intel processors employed in the MacBook Pro (13-inch, 2017) also connect directly to a variety of differential signal channels that output digital video signals through a connector, including Thunderbolt and DisplayPort through the USB-C ports.

Figure 1-1. KBL Y/U/U 4-Core and AML-Y22 Processor Line Platforms

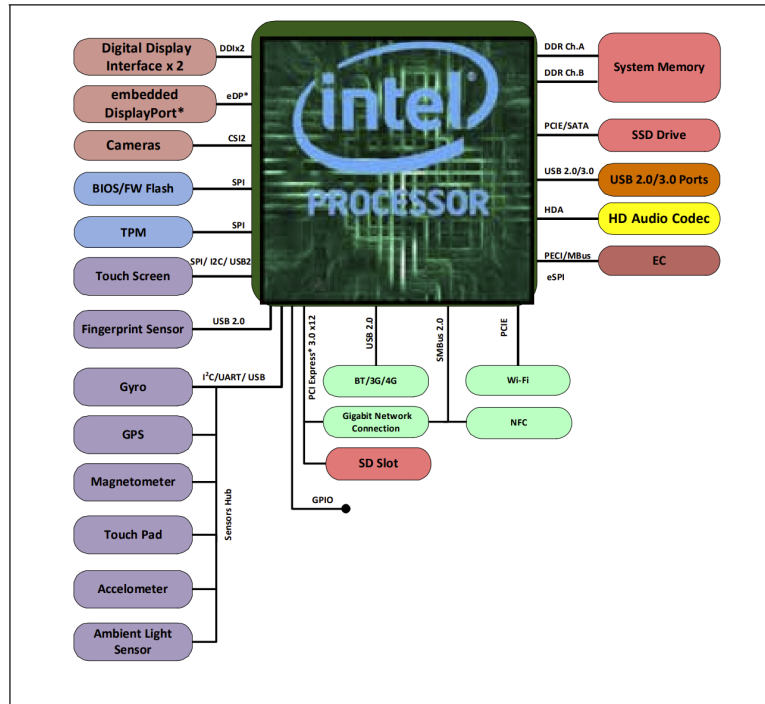

<https://www.intel.com/content/www/us/en/content-details/334661/7th-generation-intel-processor-families-for-u-y-platforms-datasheet-volume-1-of-2.html>, at 12; *id.* at 34

(explaining that the DDI channels can be configured as DisplayPort, HDMI, or DVI); *see also*

https://web.archive.org/web/20170806220029/https://support.apple.com/kb/SP754?locale=en_US (disclosing Thunderbolt and DisplayPort ports on the product).

92. The Intel processors employed in the MacBook Pro (13-inch, 2017) also connect to LVDS channels that convey USB data packets through pairs of unidirectional differential signal paths in opposite directions—USB 3.x ports.

Figure 1-1. KBL Y/U/U 4-Core and AML-Y22 Processor Line Platforms

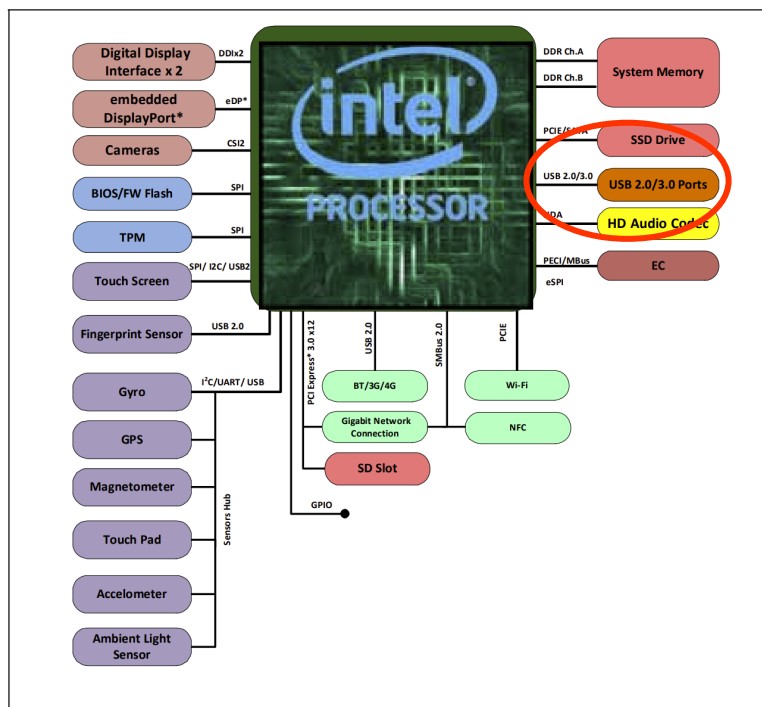

<https://www.intel.com/content/www/us/en/content-details/334661/7th-generation-intel-processor-families-for-u-y-platforms-datasheet-volume-1-of-2.html>, at 12.

93. The MacBook Pro (13-inch, 2017) has DDR3 system memory connected directly to the CPU.

Memory

- 8GB of 2133MHz LPDDR3 onboard memory
Configurable to 16GB of memory

https://web.archive.org/web/20170806220029/https://support.apple.com/kb/SP754?locale=en_US.

Figure 1-1. KBL Y/U/U 4-Core and AML-Y22 Processor Line Platforms

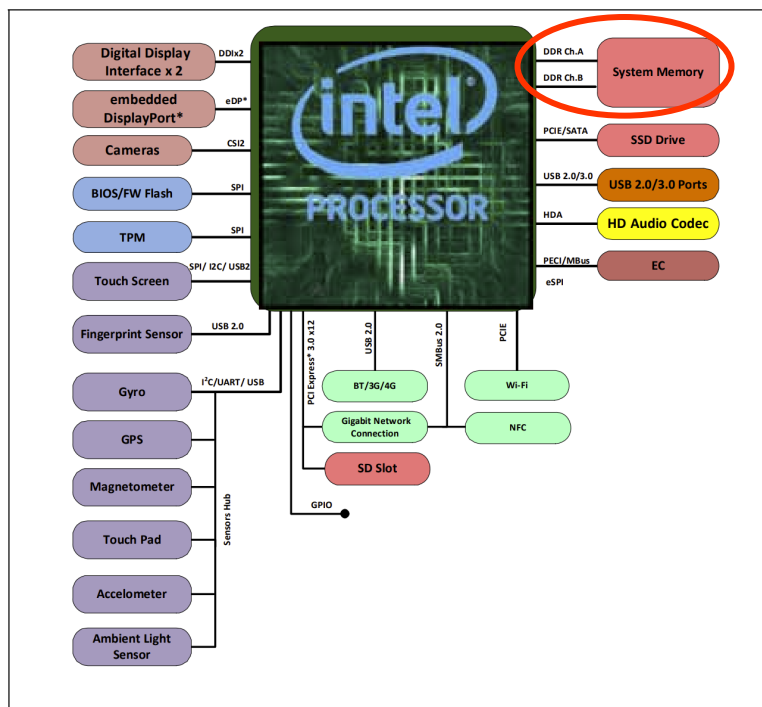

<https://www.intel.com/content/www/us/en/content-details/334661/7th-generation-intel-processor-families-for-u-y-platforms-datasheet-volume-1-of-2.html>, at 12.

94. The MacBook Pro (13-inch, 2017) has a mass storage SSD coupled to the CPU using PCIe.

Storage¹

- **128GB**
128GB PCIe-based onboard SSD
Configurable to 256GB, 512GB, or 1TB SSD
- **256GB**
256GB PCIe-based onboard SSD
Configurable to 512GB or 1TB SSD

https://web.archive.org/web/20170806220029/https://support.apple.com/kb/SP754?locale=en_US.

Figure 1-1. KBL Y/U/U 4-Core and AML-Y22 Processor Line Platforms

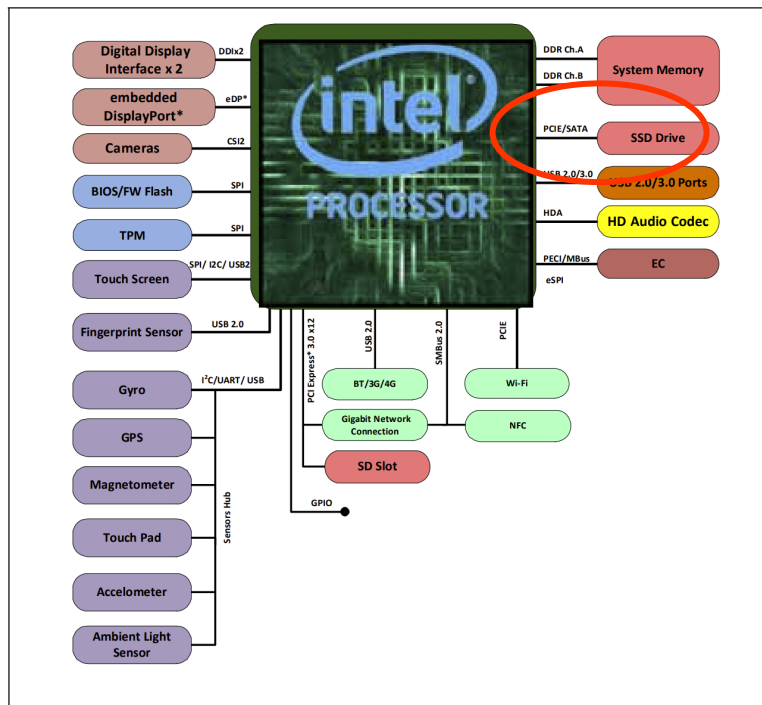

<https://www.intel.com/content/www/us/en/content-details/334661/7th-generation-intel-processor-families-for-u-y-platforms-datasheet-volume-1-of-2.html>, at 12.

95. The Intel processors used in the MacBook Pro (13-inch, 2017) have a peripheral bridge called the Platform Controller Hub (PCH) connected to the CPU module using OPI.⁵¹ Because the PCH is coupled to PCIe, USB 3.x, and other interface connections, they necessarily have integrated interface controllers to control data transmission through those interfaces. See <https://www.intel.com/content/www/us/en/content-details/334661/7th-generation-intel-processor-families-for-u-y-platforms-datasheet-volume-1-of-2.html>, at 37 (depicting connection between CPU and PCH). The U-Processor Line and Y-Processor Line are offered in a 1-Chip Platform that includes the 7th Generation Intel processor families I/O Platform Controller Hub

⁵¹ When Intel connects the processor to a chipset on the same platform as a SoC, it connects these components via OPI interface. See https://en.wikichip.org/wiki/intel/microarchitectures/kaby_lake#Sockets.2FPlatform (disclosing OPI connection between dies on SoC of the Kaby Lake U series processors).

(PCH) die on the same package as the processor die.⁵² PCH is the “chipset with centralized platform capabilities including the main I/O interfaces along with display connectivity, audio features, power management, manageability, security, and storage features.”⁵³

96. The Intel PCH used in the MacBook Pro (13-inch, 2017) has an Integrated Clock Controller (ICC) that includes PLL circuitry, which generates different clock frequencies to convey the PCI bus transactions and USB transactions through the PCIe and USB channels based on the different clock frequencies. Because the Intel processors used in the MacBook Pro (13-inch, 2017) have memory, OPI, display, and/or PCIe connections, and can send and receive data on those connections, they necessarily have integrated interface controllers to control data transmission through those interfaces.

24.2 PCH ICC Clocking Profiles

The PCH ICC hardware includes the following clocking profiles:

- “Standard” Profile (See Figure 24-1)
 - BCLK PLL = Disabled
 - USBPCIE PLL = Enabled with Down Spread Spectrum Clocking (SSC) Capability
- “Adaptive” Profile (See Figure 24-2)
 - BCLK PLL = Enabled with Down Spread Spectrum Clocking (SSC) and Under Clocking Capability
 - USBPCIE PLL = Enabled with Down Spread Spectrum Clocking (SSC) Capability
- “Over Clocking” Profile
 - BCLK PLL = Enabled with Down Spread Spectrum Clocking (SSC) and Over Clocking Capability
 - USBPCIE PLL = Enabled with Down Spread Spectrum Clocking (SSC) Capability

These PCH ICC Clocking Profiles can be enabled through the Intel[®] Flash Image Tool. Refer details in the Intel[®] ME User’s Guide within the Intel[®] ME FW Kit for steps on using the Intel[®] Flash Image Tool (FIT) tool. Table 24-1 documents the supported ICC Clocking Profiles per PCH SKU.

The Standard ICC Profile is set by default and is the recommended ICC Clocking Profile.

[https://www.intel.com/content/www/us/en/content-details/334658/7th-generation-intel-](https://www.intel.com/content/www/us/en/content-details/334658/7th-generation-intel-processor-families-for-u-y-platforms-datasheet-volume-1-of-2.html)

⁵² <https://www.intel.com/content/www/us/en/content-details/334661/7th-generation-intel-processor-families-for-u-y-platforms-datasheet-volume-1-of-2.html>, at 11.

⁵³ *Id.* at 18.

[processor-families-i-o-for-u-y-platforms-datasheet-volume-1-of-2.html](#), at 164; *see also id.* at 54-55, 165, 167, 183; Ravi Budruk, et al., PCI EXPRESS SYSTEM ARCHITECTURE, 454, (MindShare Inc., 2004), page 401.

97. In view of the foregoing facts concerning the technical features and functionalities of the Accused Quanta Laptops (*see* paragraphs 84-98), when Quanta or another party abroad manufactures the Accused Quanta Laptops, it improves the speed and performance of the peripheral data communication in its computer products by using a method of manufacturing that includes the following steps: (a) obtaining a CPU with a graphics controller in a single chip; (b) connecting one or more unidirectional differential signal channels to the CPU to output digital video data; (c) providing a connector with an LVDS channel to facilitate data communication with external peripherals; (d) providing multiple LVDS channels, connecting them to the CPU, which use one or more pairs of unidirectional lanes that convey USB protocol data and/or address, data, and/or byte enable bits of PCIe bus transaction data in serial bit streams in opposite directions; (e) connecting the CPU directly to a peripheral bridge on a circuit board; and (f) directly connecting to the peripheral bridge one or more LVDS channels with pairs of unidirectional lanes that convey data in serial bit streams in opposite directions.

98. On information and belief, Quanta or another party performs the foregoing manufacturing steps outside the United States to make at least certain of the Accused Quanta Laptops, and Quanta then imports those Accused Quanta Laptops into the United States to be marketed and sold.

The Accused Quanta Desktops

99. On information and belief, all of the Accused Quanta Desktops are configured and operate in substantially the same way as explained below using the product manufactured by

Quanta that is ultimately known as the iMac (21.5-inch, 2017) as an example for illustrative purposes.

100. The iMac (21.5-inch, 2017) is a computer system that runs the macOS operating system.



https://support.apple.com/kb/SP758?locale=en_US.

101. The iMac (21.5-inch, 2017) uses an Intel[®] Core processor, such as a 2.3GHz dual-core Intel Core i5 processor, which is mounted on a motherboard.

Processor

- 2.3GHz
2.3GHz dual-core Intel Core i5, Turbo Boost up to 3.6GHz

https://support.apple.com/kb/SP758?locale=en_US.

102. These processors are also known as the “Kaby Lake” family of processors, Intel’s 7th Generation Intel[®] Core™ i5 Processors. *See, e.g.,* <https://everymac.com/systems/apple/imac/specs/imac-core-i5-2.3-21-inch-aluminum-mid-2017-specs.html> (identifying Intel’s “Kaby Lake” processors in this product); [https://en.wikipedia.org/wiki/IMac_\(Intel-based\)#Specifications_of_slim_unibody_iMacs](https://en.wikipedia.org/wiki/IMac_(Intel-based)#Specifications_of_slim_unibody_iMacs)

(identifying the 7360U Kaby Lake / Intel Core i5 processors in this product); <https://ark.intel.com/content/www/us/en/ark/products/97535/intel-core-i57360u-processor-4m-cache-up-to-3-60-ghz.html> (specifications for the Intel® Core™ i5-7360U processors, and identifying them as 7th Generation Intel® Core™ i5 Processors, products formerly known as “Kaby Lake”).

103. The 7th Generation Intel® Core™ i5-7360U processors integrate the central processing unit (CPU) with a graphics subsystem and an interface controller on a single chip. On information and belief, the Intel Core processors integrate one or more integrated interface controllers, such as to drive the PCIe channels connected to the processor.

Figure 1-1. KBL Y/U/U 4-Core and AML-Y22 Processor Line Platforms

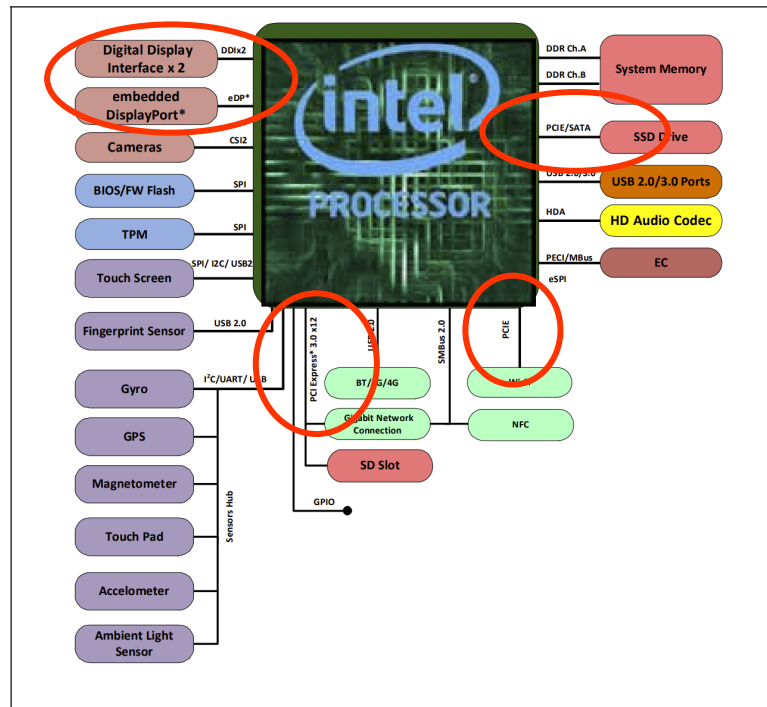

<https://www.intel.com/content/www/us/en/content-details/334661/7th-generation-intel-processor-families-for-u-y-platforms-datasheet-volume-1-of-2.html>, at 12; see also *id.* at 37.

Graphics

- Intel Iris Plus Graphics 640

https://support.apple.com/kb/SP758?locale=en_US.

Processor Graphics	
Processor Graphics † ?	Intel® Iris® Plus Graphics 640
Graphics Base Frequency ?	300 MHz
Graphics Max Dynamic Frequency ?	1.00 GHz
Graphics Video Max Memory ?	32 GB
eDRAM ?	64 MB
Graphics Output ?	eDP/DP/HDMI/DVI

<https://ark.intel.com/content/www/us/en/ark/products/97535/intel-core-i57360u-processor-4m-cache-up-to-3-60-ghz.html>.

Expansion Options	
PCI Express Revision ?	3.0
PCI Express Configurations † ?	1x4, 2x2, 1x2+2x1 and 4x1
Max # of PCI Express Lanes ?	12

<https://ark.intel.com/content/www/us/en/ark/products/97535/intel-core-i57360u-processor-4m-cache-up-to-3-60-ghz.html>.

104. The iMac (21.5-inch, 2017) comprises a chassis or enclosure which houses one or more connectors that can couple to components of other computer systems and consoles, including the USB-C⁵⁴ ports.

⁵⁴ USB Type C connectors can convey both USB protocol data as well as DisplayPort digital video. See <https://www.usb.org/sites/default/files/D2T1-4%20-%20VESA%20DP%20Alt%20Mode%20over%20USB%20Type-C.pdf>; <https://www.displayport.org/displayport-over-usb-c-7-reasons/>;



https://support.apple.com/kb/SP758?locale=en_US.

Figure 1-1. KBL Y/U/U 4-Core and AML-Y22 Processor Line Platforms

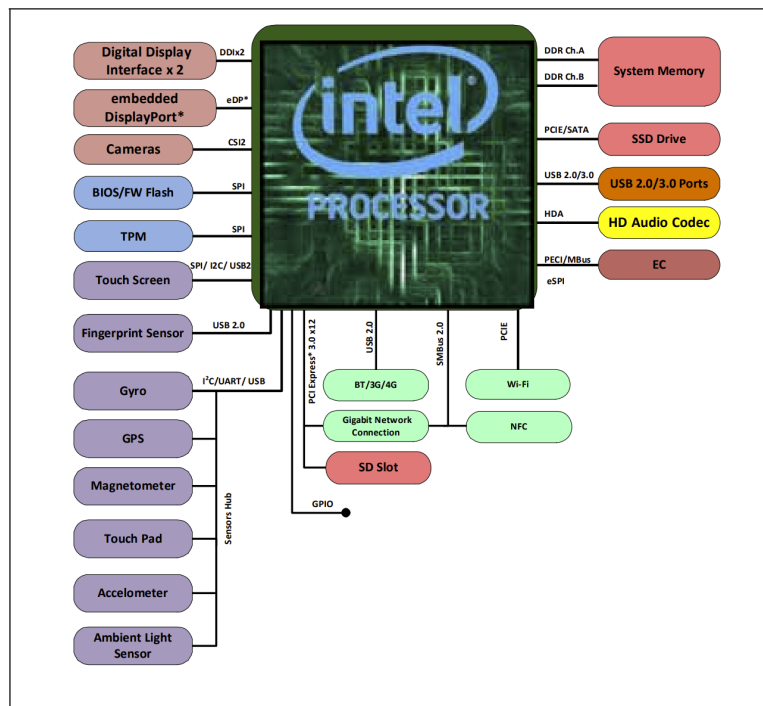

<https://www.intel.com/content/www/us/en/content-details/334661/7th-generation-intel-processor-families-for-u-y-platforms-datasheet-volume-1-of-2.html>, at 12; (identifying DDI, USB 3.x, and eDP channels extending from the SoC); *id.* at 34 (explaining that the DDI channels

<https://www.androidauthority.com/what-is-usb-type-c-594575/>.

can be configured as DisplayPort, HDMI, or DVI).

Video Support and Camera

- FaceTime HD camera
- Simultaneously supports full native resolution on the built-in display at millions of colors and:
 - One 5120-by-2880 (5K) external display at 60Hz with support for 1 billion colors, or
 - Two 3840-by-2160 (4K UHD) external displays at 60Hz with support for 1 billion colors, or
 - Two 4096-by-2304 (4K) external displays at 60Hz with support for millions of colors
- Thunderbolt 3 digital video output
- Native DisplayPort output over USB-C
- Thunderbolt 2, HDMI, DVI, and VGA output supported using adapters (sold separately)

Connections and Expansion

- 3.5 mm headphone jack
- SDXC card slot
- Four USB-A ports
- Two Thunderbolt 3 (USB-C) ports with support for:
 - DisplayPort
 - Thunderbolt (up to 40Gb/s)
 - USB 3.1 Gen 2 (up to 10Gb/s)
 - Thunderbolt 2, HDMI, DVI, and VGA supported using adapters (sold separately)
- 10/100/1000BASE-T Gigabit Ethernet (RJ-45 connector)
- Kensington lock slot

https://support.apple.com/kb/SP758?locale=en_US.

105. The Intel processors employed in the iMac (21.5-inch, 2017) connect directly to a variety of LVDS channels that convey data bits in a serial stream using unidirectional pairs of lanes transmitting data in opposite directions, including Intel's OPI⁵⁵ and PCIe channels, and the directly-connected PCIe channels connect the CPU to a mass storage device.

⁵⁵ When Intel connects the processor to a chipset on the same platform as a SoC, it connects these components via OPI interface. *See* https://en.wikichip.org/wiki/intel/microarchitectures/kaby_lake#Sockets.2FPlatform (disclosing OPI connection between dies on SoC of the Kaby Lake U series processors).

Figure 1-1. KBL Y/U/U 4-Core and AML-Y22 Processor Line Platforms

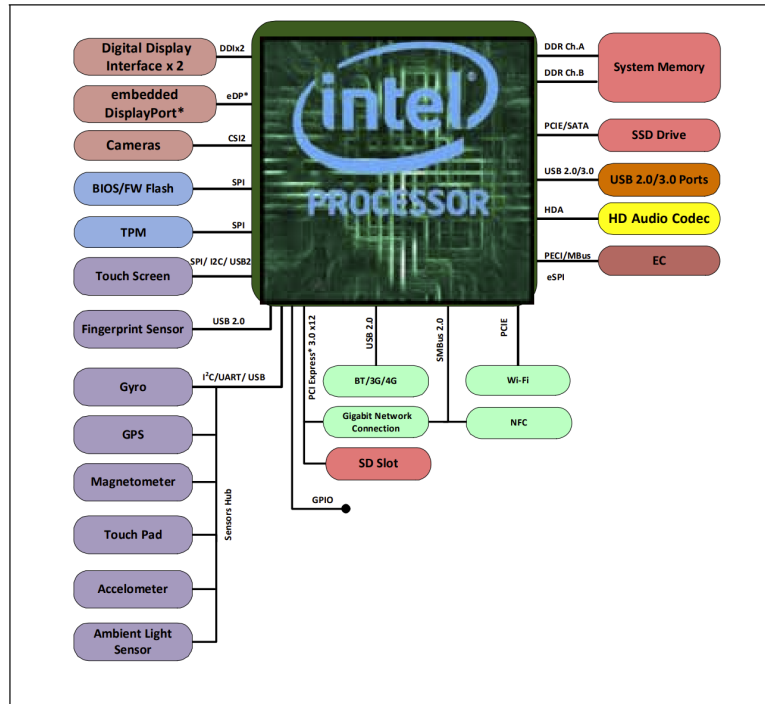

<https://www.intel.com/content/www/us/en/content-details/334661/7th-generation-intel-processor-families-for-u-y-platforms-datasheet-volume-1-of-2.html>, at 12.

106. The Intel processors employed in the iMac (21.5-inch, 2017) also connect directly to a variety of differential signal channels that output digital video signals through a connector, including DisplayPort signals through USB-C ports.

Figure 1-1. KBL Y/U/U 4-Core and AML-Y22 Processor Line Platforms

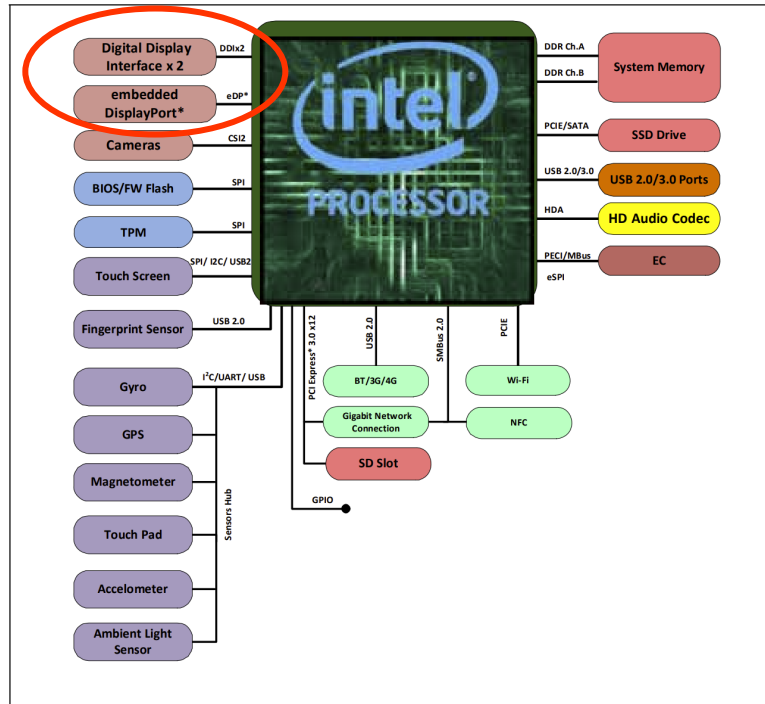

<https://www.intel.com/content/www/us/en/content-details/334661/7th-generation-intel-processor-families-for-u-y-platforms-datasheet-volume-1-of-2.html>, at 12; *id.* at 34

(explaining that the DDI channels can be configured as DisplayPort, HDMI, or DVI); *see also* https://support.apple.com/kb/SP758?locale=en_US (disclosing Thunderbolt and DisplayPort ports on the product).

107. The Intel processors employed in the iMac (21.5-inch, 2017) also connect to LVDS channels that convey USB data packets through pairs of unidirectional differential signal paths in opposite directions—USB 3.x ports.

Figure 1-1. KBL Y/U/U 4-Core and AML-Y22 Processor Line Platforms

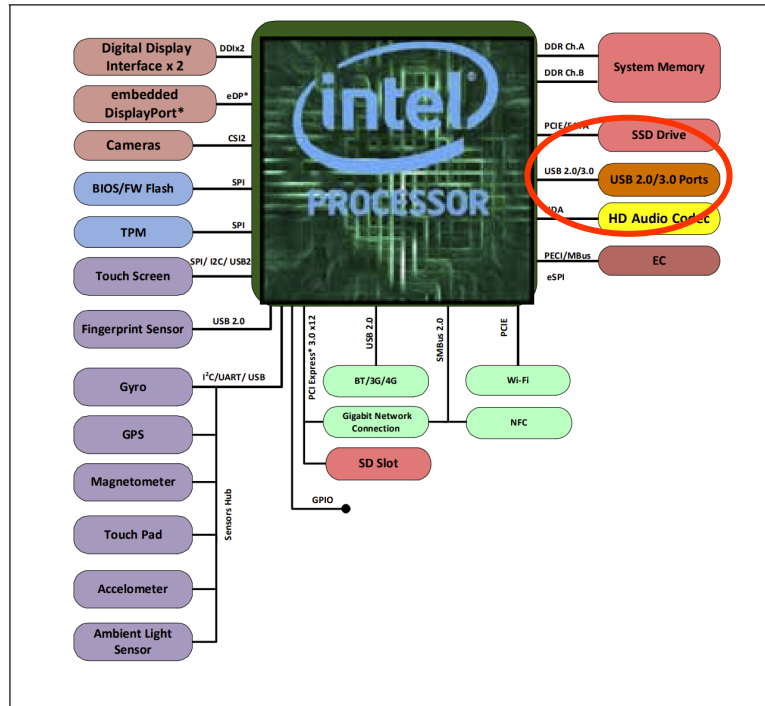

<https://www.intel.com/content/www/us/en/content-details/334661/7th-generation-intel-processor-families-for-u-y-platforms-datasheet-volume-1-of-2.html>, at 12.

108. The iMac (21.5-inch, 2017) has DDR4 system memory connected directly to the CPU.

Memory

- 2.3GHz
8GB of 2133MHz DDR4 memory
Configurable to 16GB

https://support.apple.com/kb/SP758?locale=en_US.

Figure 1-1. KBL Y/U/U 4-Core and AML-Y22 Processor Line Platforms

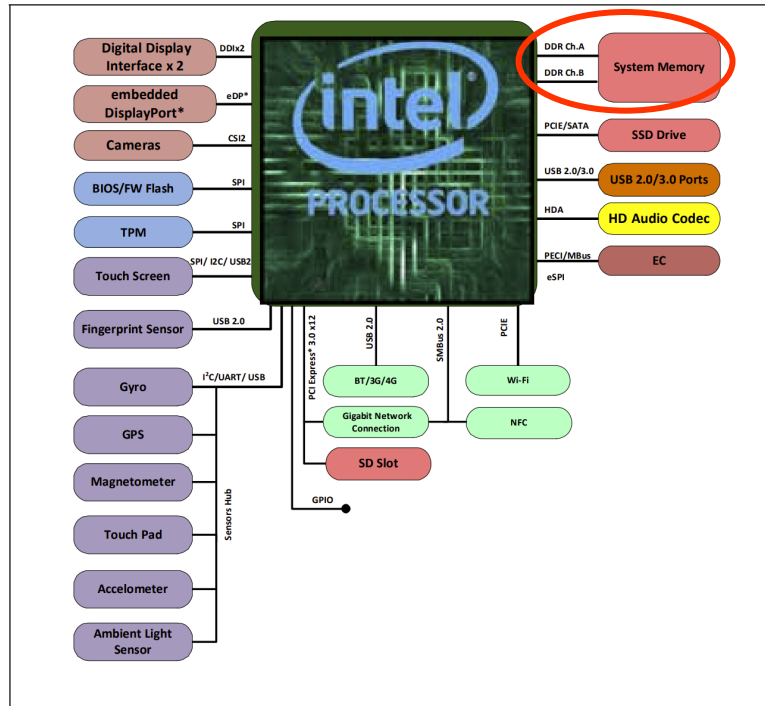

<https://www.intel.com/content/www/us/en/content-details/334661/7th-generation-intel-processor-families-for-u-y-platforms-datasheet-volume-1-of-2.html>, at 12.

109. The iMac (21.5-inch, 2017) has a mass storage hard drive or SSD coupled to the CPU.

Storage¹

- 1TB (5400-rpm) hard drive
Configurable to 1TB Fusion Drive or 256GB SSD

https://support.apple.com/kb/SP758?locale=en_US.

Figure 1-1. KBL Y/U/U 4-Core and AML-Y22 Processor Line Platforms

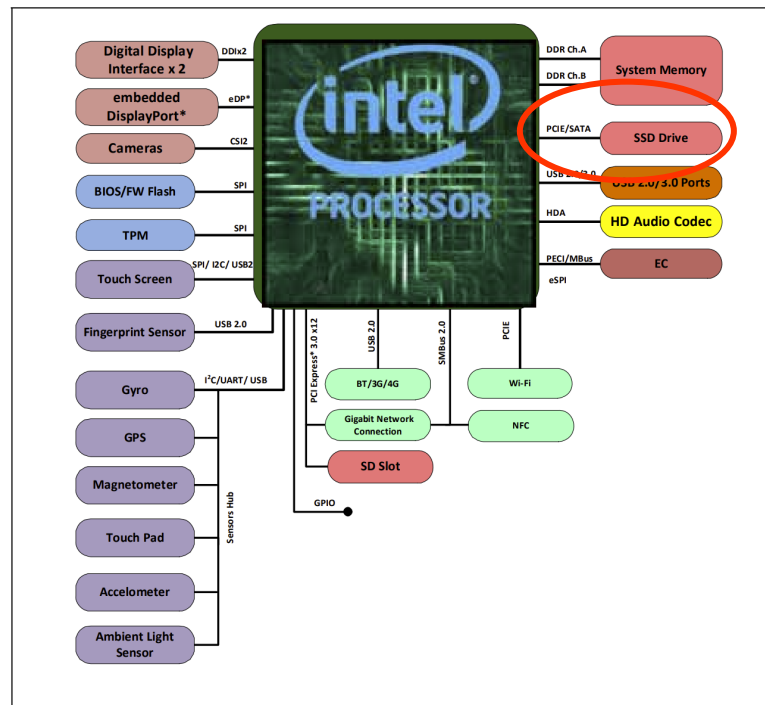

<https://www.intel.com/content/www/us/en/content-details/334661/7th-generation-intel-processor-families-for-u-y-platforms-datasheet-volume-1-of-2.html>, at 12.

110. The Intel processors used in the iMac (21.5-inch, 2017) have a peripheral bridge called the PCH connected to the CPU via the OPI.⁵⁶ Because the PCH is coupled to PCIe, USB 3.x, and other interface connections, they necessarily have integrated interface controllers to control data transmission through those interfaces. See

<https://www.intel.com/content/www/us/en/content-details/334661/7th-generation-intel-processor-families-for-u-y-platforms-datasheet-volume-1-of-2.html>, at 37 (depicting connection between CPU and PCH).

⁵⁶ When Intel connects the processor to a chipset on the same platform as a SoC, it connects these components via OPI interface. See https://en.wikichip.org/wiki/intel/microarchitectures/kaby_lake#Sockets.2FPlatform (disclosing OPI connection between dies on SoC of the Kaby Lake U series processors).

111. The Intel PCH used in the iMac (21.5-inch, 2017) has an Integrated Clock Controller (ICC) that includes PLL circuitry, which generates different clock frequencies to convey the PCI bus transactions and USB transactions through the PCIe and USB channels based on the different clock frequencies. Because the Intel processors used in the iMac (21.5-inch, 2017) have memory, DMI, display, and/or PCIe connections, and can send and receive data on those connections, they necessarily have integrated interface controllers to control data transmission through those interfaces.

24.2 PCH ICC Clocking Profiles

The PCH ICC hardware includes the following clocking profiles:

- "Standard" Profile (See Figure 24-1)
 - BCLK PLL = Disabled
 - USBPCIE PLL = Enabled with Down Spread Spectrum Clocking (SSC) Capability
- "Adaptive" Profile (See Figure 24-2)
 - BCLK PLL = Enabled with Down Spread Spectrum Clocking (SSC) and Under Clocking Capability
 - USBPCIE PLL = Enabled with Down Spread Spectrum Clocking (SSC) Capability
- "Over Clocking" Profile
 - BCLK PLL = Enabled with Down Spread Spectrum Clocking (SSC) and Over Clocking Capability
 - USBPCIE PLL = Enabled with Down Spread Spectrum Clocking (SSC) Capability

These PCH ICC Clocking Profiles can be enabled through the Intel[®] Flash Image Tool. Refer details in the Intel[®] ME User's Guide within the Intel[®] ME FW Kit for steps on using the Intel[®] Flash Image Tool (FIT) tool. Table 24-1 documents the supported ICC Clocking Profiles per PCH SKU.

The Standard ICC Profile is set by default and is the recommended ICC Clocking Profile.

<https://www.intel.com/content/www/us/en/content-details/334658/7th-generation-intel-processor-families-i-o-for-u-y-platforms-datasheet-volume-1-of-2.html>, at 164; *see also id.* at 54-55, 165, 167, 183; Ravi Budruk, et al., PCI EXPRESS SYSTEM ARCHITECTURE, 454, (MindShare Inc., 2004), page 401.

112. In view of the foregoing facts concerning the technical features and functionalities of the Accused Quanta Desktops (*see* paragraphs 99-113), when Quanta or another party manufactures the Accused Quanta Desktops, it improves the speed and performance of the

peripheral data communication in its computer products by using a method of manufacturing that includes the following steps: (a) obtaining a CPU with a graphics controller in a single chip; (b) connecting one or more unidirectional differential signal channels to the CPU to output digital video data; (c) providing a connector with an LVDS channel to facilitate data communication with external peripherals; (d) providing multiple LVDS channels, connecting them to the CPU, which use one or more pairs of unidirectional lanes that convey USB protocol data and/or address, data, and/or byte enable bits of PCIe bus transaction data in serial bit streams in opposite directions; (e) connecting the CPU directly to a peripheral bridge on a circuit board; and (f) directly connecting to the peripheral bridge one or more LVDS channels with pairs of unidirectional lanes that convey data in serial bit streams in opposite directions.

113. On information and belief, Quanta or another party performs the foregoing manufacturing steps outside the United States to make at least certain of the Accused Quanta Desktops, and Quanta then imports those Accused Quanta Desktops into the United States to be marketed and sold.

The Accused Quanta Servers

114. On information and belief, all of the Accused Quanta Servers are configured and operate in substantially the same way as explained below using the QuantaGrid D51B-1U server as an example for illustrative purposes.

115. The QuantaGrid D51B-1U is a computer.

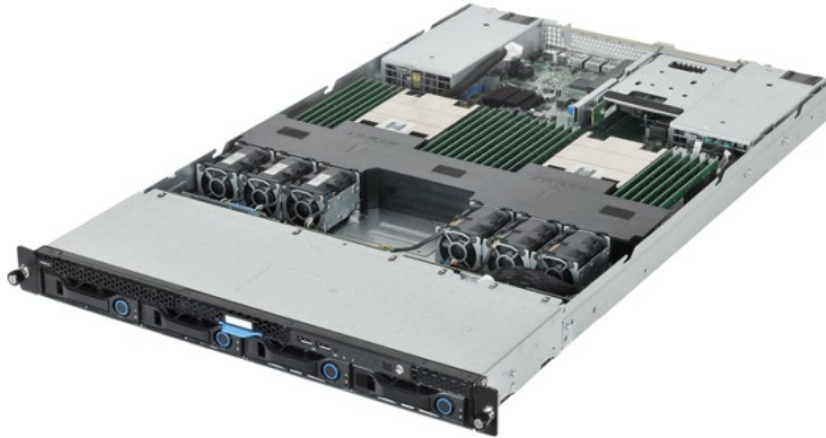

<https://web.archive.org/web/20170720101001/http://qct.io/product/index/Server/rackmount-server/1U-Rackmount-Server/QuantaGrid-D51B-1U>.

116. The QuantaGrid D51B-1U uses up to two Intel® Xeon processors, which have integrated interface controllers on a single chip, such as to drive the PCIe channels connected to the processor.

Processor	
Processor Type	Intel® Xeon® processor E5-2600 v3 product family Intel® Xeon® processor E5-2600 v4 product family
Max. TDP Support	135W (145W with limited conditions)
Number of Processors	2 Processors

Expansion Slot	
Default Configuration	Option 1 (default): (1) PCIe Gen3 x8 SAS mezzanine slot (1) PCIe Gen3 x16 FHHL (1) PCIe Gen3 x8 OCP LAN mezzanine slot Option 2: (1) PCIe Gen3 x16 LP MD-2 (1) PCIe Gen3 x16 FHHL (1) PCIe Gen3 x8 OCP LAN mezzanine slot

<https://web.archive.org/web/20170720101001/http://qct.io/product/index/Server/rackmount-server/1U-Rackmount-Server/QuantaGrid-D51B-1U#specifications>.

117. The QuantaGrid D51B-1U includes a variety of connectors that can couple the CPU to a variety of consoles, including USB 3.x.



Storage	
Default Configuration	NVMe support 2.5" Hot-plug 3.5" Hot-plug
Options	Option 1: (10) 2.5" hot-plug (including (2) optional 2.5" NVMe PCIe SSD) Option 2: (10) 2.5" hot-plug (require additional LSI SAS/ MegaRAID card to connect to the expander backplane) Option 3: (4) 3.5" hot-plug, (2) 2.5" fixed SSD
Network Controller	
LOM	Option 1: Intel® I350 dual-port 1 GbE Dedicated 1 GbE management port Option 2: Intel® X540 dual-port 10GbE BASE-T Dedicated 1 GbE management port
Front I/O	
Front I/O	2.5" SKU: None 3.5" SKU: (2) USB 2.0 ports
Rear I/O	
Rear I/O	(2) USB 3.0 ports (1) VGA port (1) RS232 serial Port (2) 1 GbE or 10G BASE-T RJ45 port (1) GbE RJ45 management port (1) ID LED (1) System LED

[https://web.archive.org/web/20170720101001/http://qct.io/product/index/Server/rackmount-server/1U-Rackmount-Server/QuantaGrid-D51B-1U#specifications.](https://web.archive.org/web/20170720101001/http://qct.io/product/index/Server/rackmount-server/1U-Rackmount-Server/QuantaGrid-D51B-1U#specifications)

118. The Intel processors employed in the QuantaGrid D51B-1U connect directly to a variety of LVDS channels that convey data bits in a serial stream using unidirectional pairs of lanes transmitting data in opposite direction, including Intel's DMI and PCIe channels, and the directly-connected PCIe channels connect the CPU to a graphics processor.

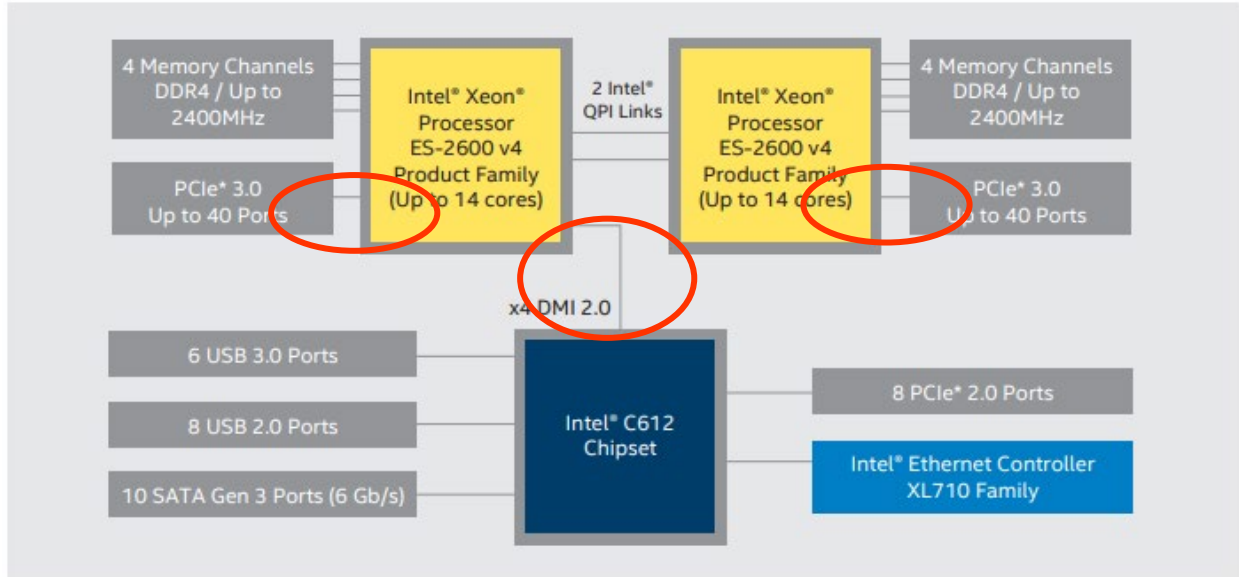

Intel® Xeon® Processor E5-2600 v4 Product Family Product Brief, *available at* <https://www.intel.com/content/www/us/en/products/platforms/details/grantley/docs.html>.

119. The Intel processors employed in the QuantaGrid D51B-1U also connect to LVDS channels that convey USB data packets through pairs of unidirectional differential signal paths in opposite directions—USB 3.x ports. *See id.; see also supra,* <https://web.archive.org/web/20170720101001/http://qct.io/product/index/Server/rackmount-server/1U-Rackmount-Server/QuantaGrid-D51B-1U#specifications>;

Abundant integrated I/Os Abundant integrated I/Os available on platform including up to 80 PCIe* Gen3 lanes, up to 10 SATA Gen3 ports, and up to 14 USB ports to fulfill the design needs.

<https://www.intel.com/content/www/us/en/products/platforms/details/grantley.html>

120. The QuantaGrid D51B-1U has DDR4 system memory connected directly to the CPU.

Memory	
Capacity	Up to 768GB RDIMM Up to 1536GB LRDIMM
Memory Type	2133/2400 MHz DDR4 RDIMM/ LRDIMM
Memory Size	32GB, 16GB, 8GB RDIMM 64GB, 32GB LRDIMM

<https://web.archive.org/web/20170720101001/http://qct.io/product/index/Server/rackmount-server/1U-Rackmount-Server/QuantaGrid-D51B-1U#specifications>.

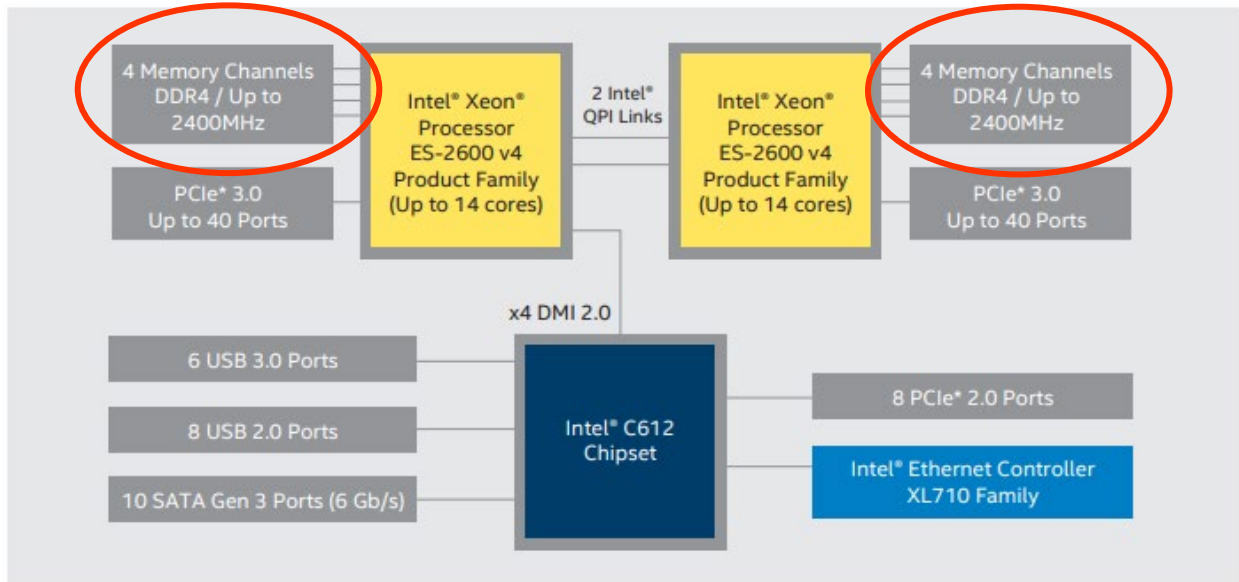

Intel® Xeon® Processor E5-2600 v4 Product Family Product Brief, *available at* <https://www.intel.com/content/www/us/en/products/platforms/details/grantley/docs.html>.

121. The QuantaGrid D51B-1U has a mass storage SSD coupled to the CPU through the onboard NVMe PCIe interface that is directly connected to the CPU through PCIe channels or a mass storage card connected to the CPU through SAS.

Storage	
Default Configuration	NVMe support 2.5" Hot-plug 3.5" Hot-plug
Options	Option 1: (10) 2.5" hot-plug (including (2) optional 2.5" NVMe PCIe SSD) Option 2: (10) 2.5" hot-plug (require additional LSI SAS/ MegaRAID card to connect to the expander backplane) Option 3: (4) 3.5" hot-plug, (2) 2.5" fixed SSD

<https://web.archive.org/web/20170720101001/http://qct.io/product/index/Server/rackmount-server/1U-Rackmount-Server/QuantaGrid-D51B-1U#specifications>.

122. The Intel processors used in the QuantaGrid D51B-1U have a peripheral bridge called the C610 series chipset PCH connected to the CPU via the DMI, which has an integrated controller.

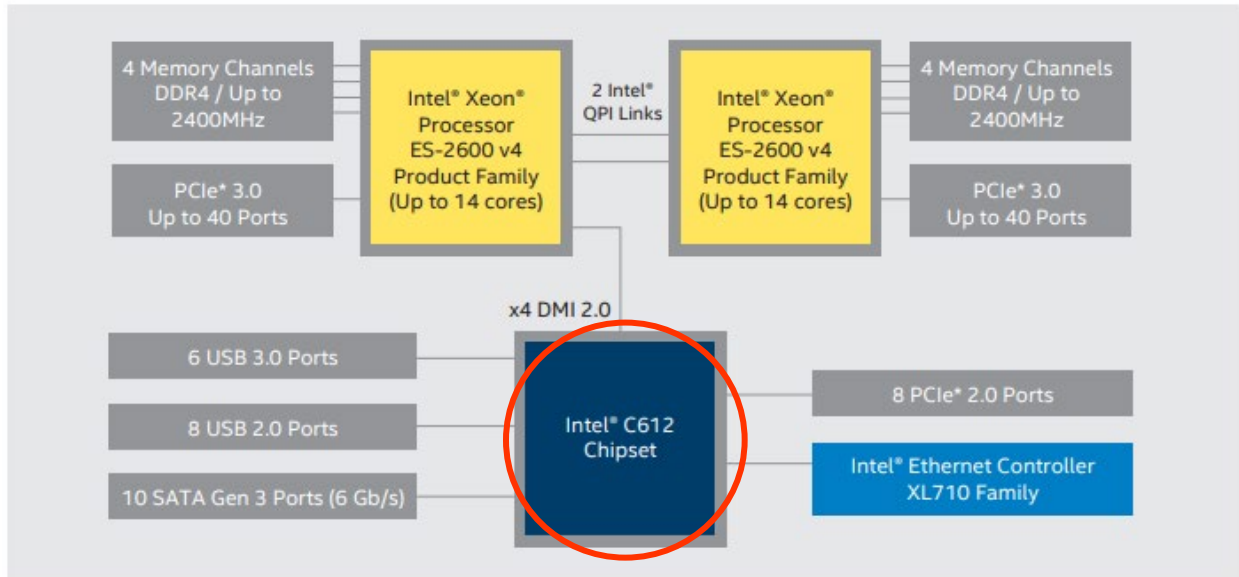

Intel® Xeon® Processor E5-2600 v4 Product Family Product Brief, *available at* <https://www.intel.com/content/www/us/en/products/platforms/details/grantley/docs.html>.

Figure 4-1. Conceptual PCH High-Level Clock Diagram (External Clocking Mode)

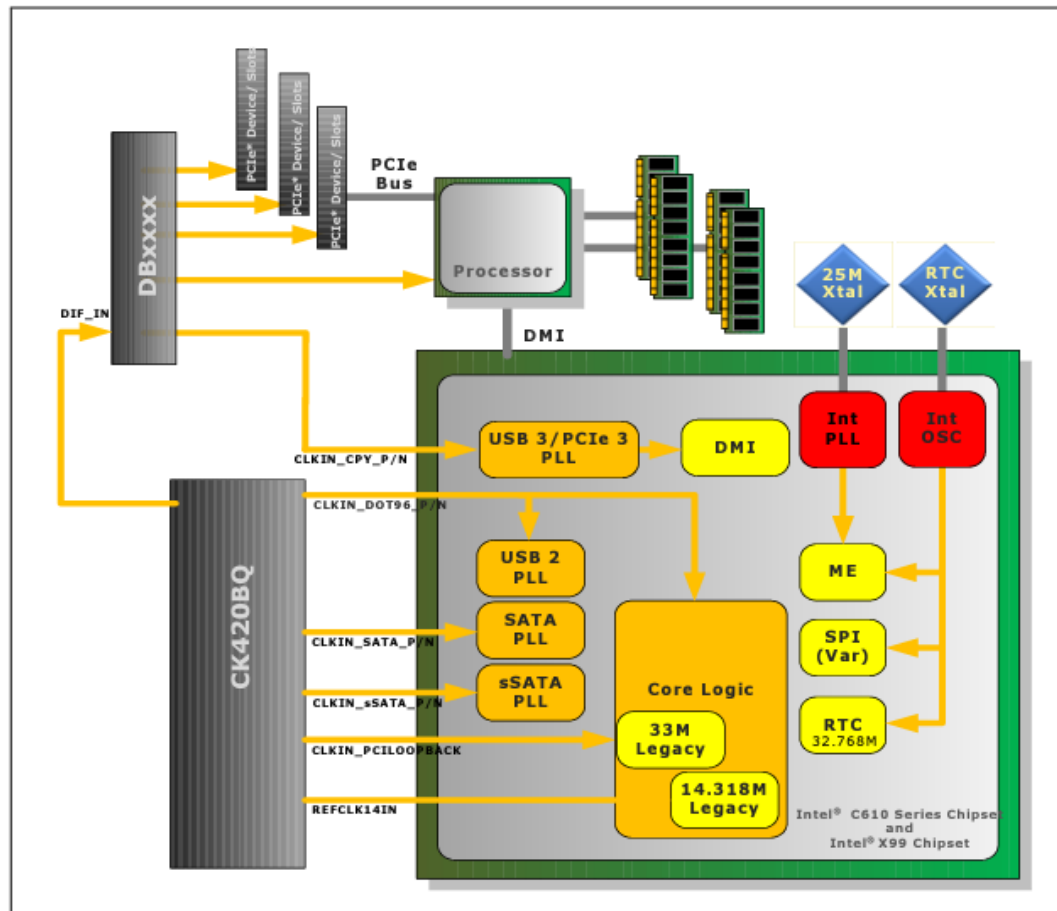

Intel® C610 Series Chipset and Intel® X99 Chipset Platform Controller Hub (PCH) Datasheet, p. 100⁵⁷ (Oct. 2015 Doc. No. 330788-003), available at <https://www.intel.com/content/dam/www/public/us/en/documents/datasheets/x99-chipset-pch-datasheet.pdf>.

⁵⁷ Page number references correspond to page numbers in PDF document.

- **Direct Media Interface**
 - Up to 2 GB/s each direction, full duplex.
 - Transparent to software
 - Supports Management Component Transport Protocol (MCTP) message forwarding
- **NEW: Flexible IO**
 - A new architecture that allows some high speed IO signals to be configured as SATA or USB 3.0 or PCIe*
- **PCI Express***
 - Up to eight PCI Express root ports
 - Supports PCI Express Rev 2.0 running at up to 5.0 GT/s
 - Ports 1-4 and 5-8 can independently be configured to support multiple port configurations
 - Module based Hot-Plug supported (that is, ExpressCard*)
 - NEW: Latency Tolerance Reporting
 - NEW: Optimized Buffer Flush/Fill

Id. at p. 35.

123. The Intel C610 series PCH used in the QuantaGrid D51B-1U has an Integrated Clock Controller (ICC) that includes PLL circuitry, which generates different clock frequencies to convey the PCI bus transactions and USB transactions through the PCIe and USB channels based on the different clock frequencies.

Integrated Clock Controller

The PCH contains an Integrated Clock Controller (ICC) that generates various platform clocks from a 25 MHz crystal source. The ICC contains PLLs, Modulators and Dividers for generating various clocks suited to the platform needs. The ICC supplies up to eleven 100 MHz PCI Express 3.0 Specification compliant clocks for PCIe* device, two 100 MHz PCI Express 3.0 Specification compliant clock for BCLK/DMI, one 100 MHz PCI Express 3.0 Specification compliant clock for ITP, five 33 MHz PCI 2.3 Local Bus Specification compliant single-ended clocks for LPC/TPM devices and four Flex Clocks that can be configured to frequencies that include 14.318 MHz, 33 MHz and 24/48 MHz for use with SIO, TPM, EC, LPC and any other legacy functions.

Id. at p. 45.

4.4 Functional Blocks

The PCH has one main PLL in which its output is divided down through Modulators and Dividers to provide great flexibility in clock source selection, configuration, and better power management.

Table 4-7 describes the PLLs on the PCH and the clock domains that are driven from the PLLs.

Table 4-7. PCH PLLs

PLL	Outputs ¹	Description/Usage
XCK_PLL	Four 2.7 GHz outputs 90° apart. Outputs are routed to each of the Spread Modulator blocks before hitting the various dividers and the other PLLs to provide clocks to all of the I/O interface logic. Also provides 5.4 GHz and 2.7 GHz CMOS outputs for use by various dividers to create non-spread output clocks.	Main Reference PLL. Always enabled in Integrated Clocking mode. Resides in core power well and is not powered in S3 and below states.

Notes:

1. Indicates the source clock frequencies driven to other internal logic for delivering functionality needed. Does not indicate external outputs
2. Powered in sub-S0 states by a Suspend well Ring oscillator.

Intel® C610 Series Chipset and Intel® X99 Chipset Platform Controller Hub (PCH) Datasheet, p.

100 (Oct. 2015 Doc. No. 330788-003), available at

<https://www.intel.com/content/dam/www/public/us/en/documents/datasheets/x99-chipset-pch-datasheet.pdf>.

Figure 4-1. Conceptual PCH High-Level Clock Diagram (External Clocking Mode)

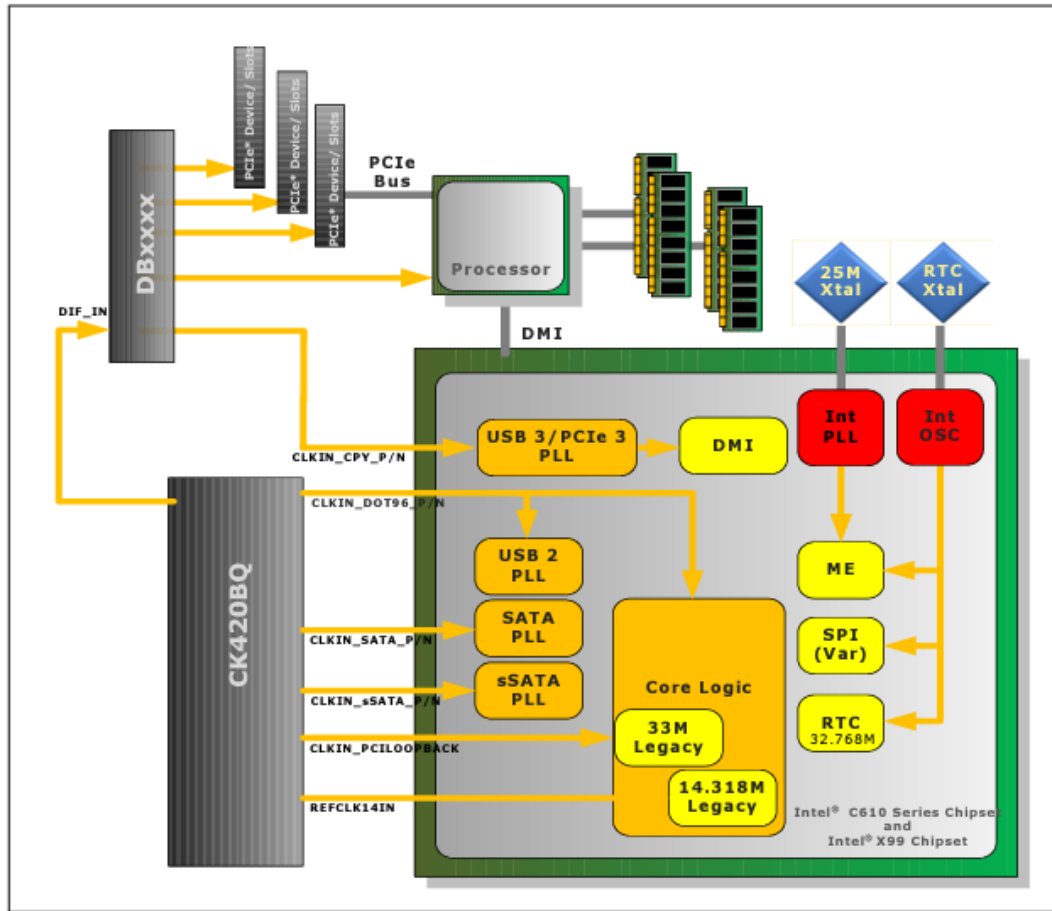

Id. at p. 101.

124. The Intel Xeon processor used in the QuantaGrid D51B-1U also has integrated clock circuitry that includes PLL circuitry, which generates different clock frequencies to convey the PCI bus transactions through the PCIe channels based on the different clock frequencies.

2.2.6 System Reference Clocks (BCLK{0/1}_DP, BCLK{0/1}_DN)

The processor Core, processor Uncore, Intel® QuickPath Interconnect link, PCI Express* and DDR4 memory interface frequencies) are generated from BCLK{0/1}_DP and BCLK{0/1}_DN signals. There is no direct link between core frequency and Intel QuickPath Interconnect link frequency (e.g., no core frequency to Intel QuickPath Interconnect multiplier). The processor maximum core frequency, Intel QuickPath Interconnect link frequency and DDR memory frequency are set during manufacturing. It is possible to override the processor core frequency setting using software (see the *Intel® 64 and IA-32 Architectures Software Developer's Manuals*). This permits operation at lower core frequencies than the factory set maximum core frequency.

The processor core frequency is configured during reset by using values stored within the device during manufacturing. The stored value sets the lowest core multiplier at which the particular processor can operate. If higher speeds are desired, the appropriate ratio can be configured via the IA32_PERF_CTL MSR (MSR 199h); Bits [15:0]. For details of operation at core frequencies lower than the maximum rated processor speed, refer to the *Intel® 64 and IA-32 Architectures Software Developer's Manuals*.

Clock multiplying within the processor is provided by the internal phase locked loop (PLL), which requires a constant frequency BCLK{0/1}_DP, BCLK{0/1}_DN input, with exceptions for spread spectrum clocking. DC specifications for the BCLK{0/1}_DP, BCLK{0/1}_DN inputs are provided in [Processor Asynchronous Sideband DC Specifications](#) on page 42. These specifications must be met while also meeting the associated signal quality specifications outlined in [Signal Quality](#) on page 45.

Intel® Xeon® Processor E5 v4 Product Family Datasheet, Vol. One: Electrical, p. 16 (June 2016 Doc. No. 333809-003US), available at <https://www.intel.com/content/www/us/en/content-details/333809/intel-xeon-processor-e5-v4-family-volume-1-of-2-electrical-datasheet.html>.

System Reference Clock (BCLK{0/1}) Signals

Signal Name	Description
BCLK{0/1}_D[N/P]	Reference Clock Differential input. These pins provide the required reference inputs to various PLLs inside the processor, such as Intel QPI and PCIe. BCLK0 and BCLK1 run at 100MHz from the same clock source.

Id. at p. 53.

Figure 4-1. Conceptual PCH High-Level Clock Diagram (External Clocking Mode)

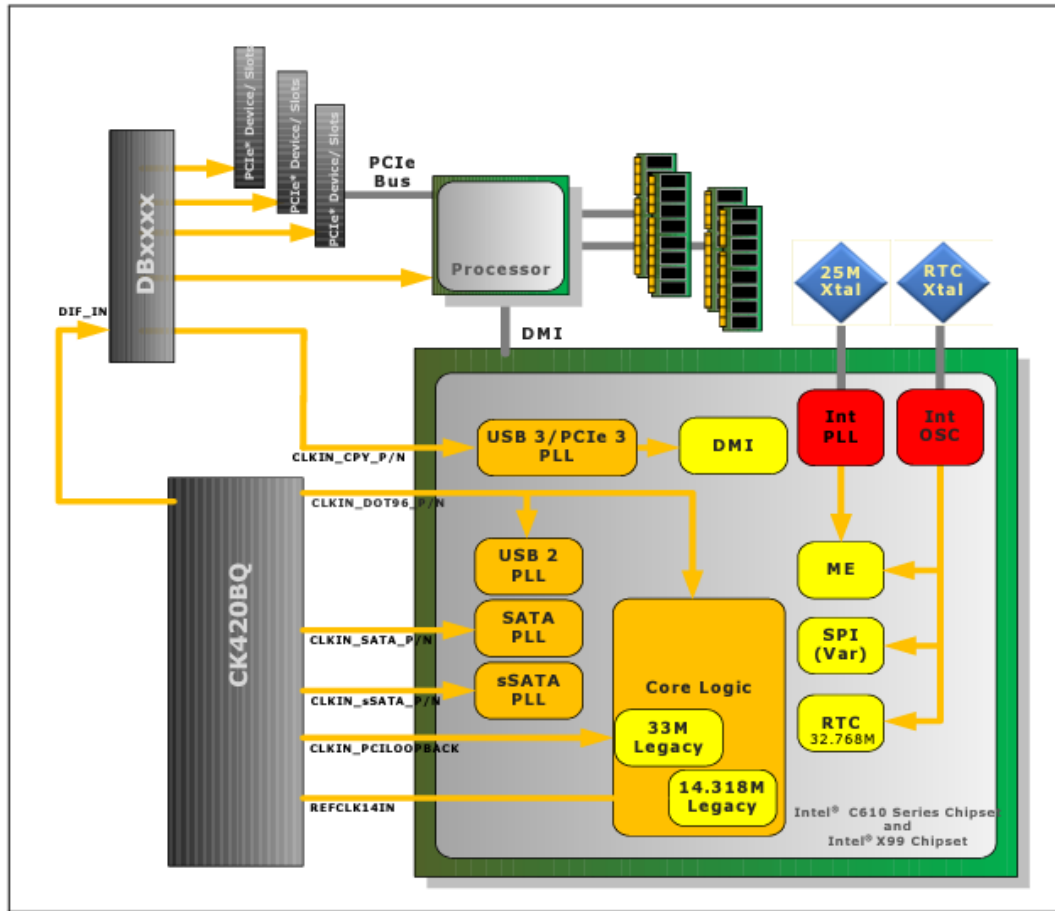

Intel® C610 Series Chipset and Intel® X99 Chipset Platform Controller Hub (PCH) Datasheet, p. 100 (Oct. 2015 Doc. No. 330788-003), available at <https://www.intel.com/content/dam/www/public/us/en/documents/datasheets/x99-chipset-pch-datasheet.pdf>.

125. In view of the foregoing facts concerning the technical features and functionalities of the Accused Quanta Servers (*see* paragraphs 114-128), when Quanta or another party manufactures the Accused Quanta Servers, it improves the speed and performance of the peripheral data communication in its computer products by using a method of manufacturing that includes the following steps: (a) connecting a CPU directly to a peripheral bridge on a printed

circuit board; (b) directly connecting to the peripheral bridge one or more LVDS channels with pairs of unidirectional lanes that convey data in serial bit streams in opposite directions; and (c) providing a connector with an LVDS channel to facilitate data communication with external peripherals using two unidirectional serial lanes to transmit data in opposite directions, including USB protocol data.

126. On information and belief, Quanta or another party performs the foregoing manufacturing steps outside the United States to make at least certain of the Accused Quanta Servers, and Quanta then imports those Accused Quanta Servers into the United States to be marketed and sold.

127. Through making, using, selling, and/or offering for sale in the United States, and/or importing into the United States, the Accused Quanta Products with the features and functionalities alleged above, Quanta has infringed one or more of the claims in each of the ACQIS Patents.

128. Quanta's infringing conduct has caused injury and damage to ACQIS and ACQIS' licensees.

ACQIS Provided Quanta Actual Notice of its Infringement

129. On or around May 14, 2018, ACQIS notified Quanta, pursuant to 35 U.S.C. § 287(a), of all of the ACQIS Patents and Quanta's infringement thereof based on the Accused Quanta Products. Specifically, ACQIS' letter identified all of the ACQIS Patents asserted herein and described the applicability of the ACQIS Patents to Quanta's "X86 compatible notebook, desktop computer, motherboard and server products." ACQIS provided examples of relevant server products: "Server product series – QuantaGrid, QuantaPlex, Stratos, QSSC, QuantaMicro, Rackgo X, Rackgo M, S1M, JBR, JBFA and similar products." ACQIS also described the

enforcement history of ACQIS's patent portfolio, and specifically noted a prior lawsuit enforcing ACQIS Patents related to the presently-asserted ACQIS Patents, which resulted in a significant jury verdict against IBM.

130. ACQIS invited Quanta to discuss potential licensing arrangements to allow Quanta to continue to utilize the patented technologies in the ACQIS patent portfolio, including the ACQIS Patents.

131. Quanta did not respond to ACQIS's May 14, 2018 letter and continued to make, import, and sell the Accused Quanta Products identified in ACQIS's letter in willful violation of ACQIS' patent rights, or at the very least in reckless disregard of ACQIS' patent rights.

132. Upon receiving actual notice of the ACQIS Patents and how they apply to Quanta's computer products, Quanta at the very least ignored the notice and chose to remain willfully blind to its own infringement.

133. Quanta's choice to ignore ACQIS, the ACQIS Patents, and ACQIS' offer to engage in a licensing arrangement, and instead to continue making and selling the infringing Accused Quanta Products, is egregious and exceptional.

134. Quanta's conduct constitutes willful infringement of the ACQIS Patents, beginning at least as early as May 14, 2018.

COUNT I
INFRINGEMENT OF U.S. PATENT NO. 9,529,768

135. ACQIS incorporates by this reference the allegations set forth in paragraphs 1-134 of this Complaint in support of its first cause of action as though fully set forth herein.

136. Pursuant to 35 U.S.C. § 282, the claims of the '768 patent are presumed valid.

137. In view of the foregoing facts and allegations, including paragraphs 70-128 above, Quanta has directly infringed one or more claims of the '768 patent in violation of 35 U.S.C. §

271(a) by making, using, selling, offering to sell, and/or importing the Accused Quanta Products.

138. Quanta's infringement of the '768 patent through its manufacture, use, offers to sell, and/or sales in, and/or importation into, the United States of the Accused Quanta Laptops is shown by way of the exemplary laptop, the MacBook Pro (13-inch, 2017) laptop as set forth in paragraphs 84-98 above, which demonstrates infringement of at least claim 13 of the '768 patent by showing:

- (a) the exemplary laptop is a computer;
- (b) the exemplary laptop has an integrated central processing unit (CPU) and interface controller in a single chip, because the exemplary laptop uses a 7th Generation Intel® Core™ i5 (“Kaby Lake”) Processor, which includes interface controllers (*e.g.*, to drive PCIe channels) and the CPU integrated as a single chip;
- (c) the exemplary laptop has a first LVDS channel directly extending from the interface controller to convey address and data bits of a PCI bus transaction in a serial bit stream, wherein the first LVDS channel comprises first unidirectional, multiple, differential signal pairs to convey data in a first direction and second unidirectional, multiple, differential signal pairs to convey data in a second, opposite direction opposite directions through different numbers of differential signal pairs, because the 7th Generation Intel® Core™ i5 (“Kaby Lake”) Processors employed in the exemplary laptop include PCIe channels directly extending from the interface controller;
- (d) the exemplary laptop has system memory directly coupled to the integrated CPU and interface controller, because the 7th Generation Intel® Core™ i5 (“Kaby Lake”) Processors employed in the exemplary laptop are directly coupled to DDR3

system memory.

139. On information and belief, the Accused Quanta Laptops are in relevant part substantially similar to the exemplary laptop, in particular with regard to the manner in which the Accused Quanta Laptops include and utilize PCIe and/or USB 3.x functionality. This Section is thus illustrative of the manner in which Quanta infringes the claims of the '768 patent as to each of the Accused Quanta Laptops.

140. ACQIS' infringement allegations against the Accused Quanta Laptops are not limited to claim 13 of the '768 patent, and additional infringed claims will be identified through infringement contentions and discovery.

141. Quanta's infringement of the '768 patent through its manufacture, use, offers to sell, and/or sales in, and/or importation into, the United States of the Accused Quanta Desktops is shown by way of the exemplary desktop, the iMac (21.5-inch, 2017) as set forth in paragraphs 99-113 above, which demonstrates infringement of at least claim 13 of the '768 patent by showing:

- (a) the exemplary desktop is a computer;
- (b) the exemplary desktop has an integrated central processing unit (CPU) and interface controller in a single chip, because the exemplary desktop uses a 7th Generation Intel® Core™ i5 ("Kaby Lake") Processor, which includes interface controllers (*e.g.*, to drive PCIe channels) and the CPU integrated as a single chip;
- (c) the exemplary desktop has a first LVDS channel directly extending from the interface controller to convey address and data bits of a PCI bus transaction in a serial bit stream, wherein the first LVDS channel comprises first unidirectional, multiple, differential signal pairs to convey data in a first direction and second unidirectional, multiple, differential signal pairs to convey data in a second, opposite direction opposite

directions through different numbers of differential signal pairs, including but not limited to its PCIe and OPI channels, because the 7th Generation Intel® Core™ i5 (“Kaby Lake”) Processors employed in the exemplary desktop include PCIe channels directly extending from the interface controller;

- (d) the exemplary desktop has system memory directly coupled to the integrated CPU and interface controller, because the 7th Generation Intel® Core™ i5 (“Kaby Lake”) Processors employed in the exemplary desktop are directly coupled to DDR4 system memory.

142. On information and belief, the Accused Quanta Desktops are in relevant part substantially similar to the exemplary desktop, in particular with regard to the manner in which the Accused Quanta Desktops include and utilize PCIe and/or USB 3.x functionality. This Section is thus illustrative of the manner in which Quanta infringes the claims of the ’768 patent as to each of the Accused Quanta Desktops.

143. ACQIS’ infringement allegations against the Accused Quanta Desktops are not limited to claim 13 of the ’768 patent, and additional infringed claims will be identified through infringement contentions and discovery.

144. Quanta’s infringement of the ’768 patent through its manufacture, use, offers to sell, and/or sales in, and/or importation into, the United States of the Accused Quanta Servers is shown by way of the exemplary the exemplary QuantaGrid D51B-1U server as set forth in paragraphs 114-128 above, which demonstrates infringement of at least claim 13 of the ’768 patent by showing:

- (a) the QuantaGrid D51B-1U is a computer;
- (b) the QuantaGrid D51B-1U has an integrated central processing unit (CPU) and

interface controller in a single chip, because the QuantaGrid D51B-1U uses Intel[®] Xeon processors, which include interface controllers (*e.g.*, to drive PCIe channels) and the CPU integrated as a single chip;

- (c) the QuantaGrid D51B-1U has a first LVDS channel directly extending from the interface controller to convey address and data bits of a PCI bus transaction in a serial bit stream, wherein the first LVDS channel comprises first unidirectional, multiple, differential signal pairs to convey data in a first direction and second unidirectional, multiple, differential signal pairs to convey data in a second, opposite direction opposite directions through different numbers of differential signal pairs, because the Intel[®] Xeon processors employed in the QuantaGrid D51B-1U include PCIe channels directly extending from the interface controller;
- (d) the QuantaGrid D51B-1U has system memory directly coupled to the integrated CPU and interface controller, because the Intel[®] Xeon processors employed in the QuantaGrid D51B-1U are directly coupled to DDR4 system memory.

145. On information and belief, the Accused Quanta Servers are in relevant part substantially similar to the exemplary QuantaGrid products, in particular with regard to the manner in which the Accused Quanta Servers include and utilize PCIe and/or USB 3.x functionality. This Section is thus illustrative of the manner in which Quanta infringes the claims of the '768 patent as to each of the Accused Quanta Servers.

146. ACQIS' infringement allegations against the Accused Quanta Servers are not limited to claim 13 of the '768 patent, and additional infringed claims will be identified through infringement contentions and discovery.

147. As early as around May 14, 2018, Quanta had actual notice of the '768 patent and the infringement alleged herein.

148. The above-described acts of infringement committed by Quanta have caused injury and damage to ACQIS and ACQIS' licensees.

149. ACQIS is entitled to recover all damages sustained as a result of Quanta's wrongful acts of infringement, but in no event less than a reasonable royalty pursuant to 35 U.S.C. § 284.

150. Quanta's infringement as described herein has been willful and exceptional. Accordingly, ACQIS is entitled to recover enhanced damages up to three times the amount found or assessed at trial pursuant to 35 U.S.C. § 284, as well as its attorneys' fees pursuant to 35 U.S.C. § 285.

COUNT II INFRINGEMENT OF U.S. PATENT NO. 9,703,750

151. ACQIS incorporates by this reference the allegations set forth in paragraphs 1-134 of this Complaint in support of its second cause of action as though fully set forth herein.

152. Pursuant to 35 U.S.C. § 282, the claims of the '750 patent are presumed valid.

153. In view of the foregoing facts and allegations, including paragraphs 70-128 above, Quanta has directly infringed one or more claims of the '750 patent in violation of 35 U.S.C. § 271(a) by making, using, selling, offering to sell, and/or importing the Accused Quanta Products.

154. Quanta's infringement of the '750 patent through its manufacture, use, offers to sell, and/or sales in, and/or importation into, the United States of the Accused Quanta Laptops is shown by way of the exemplary laptop, the MacBook Pro (13-inch, 2017) laptop as set forth in paragraphs 84-98 above, which demonstrates infringement of at least claim 1 of the '750 patent by showing:

(a) the exemplary laptop is a computer;

- (b) the exemplary laptop has an integrated central processing unit (CPU) and interface controller in a single chip, because the exemplary laptop uses a 7th Generation Intel® Core™ i5 (“Kaby Lake”) Processor, which includes interface controllers (*e.g.*, to drive PCIe channels) and the CPU integrated as a single chip;
- (c) the exemplary laptop has a first LVDS channel directly extending from the interface controller to convey address bits, data bits, and byte enable information bits of a PCI bus transaction in a serial bit stream, wherein the first LVDS channel comprises a first unidirectional, differential signal pair to convey data in a first direction and a second unidirectional, differential signal pair to convey data in a second, opposite direction, because the 7th Generation Intel® Core™ i5 (“Kaby Lake”) Processors employed in the exemplary laptop include numerous PCIe channels directly extending from the interface controller;
- (d) the exemplary laptop has system memory directly coupled to the integrated CPU and interface controller, because the 7th Generation Intel® Core™ i5 (“Kaby Lake”) Processors employed in the exemplary laptop are directly coupled to DDR3 system memory.

155. On information and belief, the Accused Quanta Laptops are in relevant part substantially similar to the exemplary laptop, in particular with regard to the manner in which the Accused Quanta Laptops include and utilize PCIe and/or USB 3.x functionality. This Section is thus illustrative of the manner in which Quanta infringes the claims of the ’750 patent as to each of the Accused Quanta Laptops.

156. ACQIS' infringement allegations against the Accused Quanta Laptops are not limited to claim 1 of the '750 patent, and additional infringed claims will be identified through infringement contentions and discovery.

157. Quanta's infringement of the '750 patent through its manufacture, use, offers to sell, and/or sales in, and/or importation into, the United States of the Accused Quanta Desktops is shown by way of the exemplary desktop, the iMac (21.5-inch, 2017) as set forth in paragraphs 99-113 above, which demonstrates infringement of at least claim 1 of the '750 patent by showing:

- (a) the exemplary desktop is a computer;
- (b) the exemplary desktop has an integrated central processing unit (CPU) and interface controller in a single chip, because the exemplary desktop uses a 7th Generation Intel® Core™ i5 ("Kaby Lake") Processor, which includes interface controllers (*e.g.*, to drive PCIe channels) and the CPU integrated as a single chip;
- (c) the exemplary desktop has a first LVDS channel directly extending from the interface controller to convey address bits, data bits, and byte enable information bits of a PCI bus transaction in a serial bit stream, wherein the first LVDS channel comprises a first unidirectional, differential signal pair to convey data in a first direction and a second unidirectional, differential signal pair to convey data in a second, opposite direction, because the 7th Generation Intel® Core™ i5 ("Kaby Lake") Processors employed in the exemplary desktop include PCIe channels directly extending from the interface controller;
- (d) the exemplary desktop has system memory directly coupled to the integrated CPU and interface controller, because the 7th Generation Intel® Core™ i5 ("Kaby Lake") Processors employed in the exemplary desktop are directly coupled to DDR4

system memory.

158. On information and belief, the Accused Quanta Desktops are in relevant part substantially similar to the exemplary desktop, in particular with regard to the manner in which the Accused Quanta Desktops include and utilize PCIe and/or USB 3.x functionality. This Section is thus illustrative of the manner in which Quanta infringes the claims of the '750 patent as to each of the Accused Quanta Desktops.

159. ACQIS' infringement allegations against the Accused Quanta Desktops are not limited to claim 1 of the '750 patent, and additional infringed claims will be identified through infringement contentions and discovery.

160. Quanta's infringement of the '750 patent through its manufacture, use, offers to sell, and/or sales in, and/or importation into, the United States of the Accused Quanta Servers is shown by way of the exemplary the Accused Quanta Servers is shown by way of the exemplary QuantaGrid D51B-1U server as set forth in paragraphs 114-128 above, which demonstrates infringement of at least claim 1 of the '750 patent by showing:

- (a) the QuantaGrid D51B-1U is a computer;
- (b) the QuantaGrid D51B-1U has an integrated central processing unit (CPU) and interface controller in a single chip, because the QuantaGrid D51B-1U uses Intel[®] Xeon processors, which include interface controllers (*e.g.*, to drive PCIe channels) and the CPU integrated as a single chip;
- (c) the QuantaGrid D51B-1U has a first LVDS channel directly extending from the interface controller to convey address bits, data bits, and byte enable information bits of a PCI bus transaction in a serial bit stream, wherein the first LVDS channel comprises a first unidirectional, differential signal pair to convey data in a first

direction and a second unidirectional, differential signal pair to convey data in a second, opposite direction, because the Intel[®] Xeon processors employed in the QuantaGrid D51B-1U include PCIe channels directly extending from the interface controller;

- (d) the QuantaGrid D51B-1U has system memory directly coupled to the integrated CPU and interface controller, because the Intel[®] Xeon processors employed in the QuantaGrid D51B-1U are directly coupled to DDR4 system memory.

161. On information and belief, the Accused Quanta Servers are in relevant part substantially similar to the exemplary QuantaGrid products, in particular with regard to the manner in which the Accused Quanta Servers include and utilize PCIe and/or USB 3.x functionality. This Section is thus illustrative of the manner in which Quanta infringes the claims of the '750 patent as to each of the Accused Quanta Servers.

162. ACQIS' infringement allegations against the Accused Quanta Servers are not limited to claim 1 of the '750 patent, and additional infringed claims will be identified through infringement contentions and discovery.

163. As early as around May 14, 2018, Quanta had actual notice of the '750 patent and the infringement alleged herein.

164. The above-described acts of infringement committed by Quanta have caused injury and damage to ACQIS and ACQIS' licensees.

165. ACQIS is entitled to recover all damages sustained as a result of Quanta's wrongful acts of infringement, but in no event less than a reasonable royalty pursuant to 35 U.S.C. § 284.

166. Quanta's infringement as described herein has been willful and exceptional. Accordingly, ACQIS is entitled to recover enhanced damages up to three times the amount found

or assessed at trial pursuant to 35 U.S.C. § 284, as well as its attorneys' fees pursuant to 35 U.S.C. § 285.

COUNT III
INFRINGEMENT OF U.S. PATENT NO. 8,756,359

167. ACQIS incorporates by this reference the allegations set forth in paragraphs 1-134 of this Complaint in support of its third cause of action as though fully set forth herein.

168. Pursuant to 35 U.S.C. § 282, the claims of the '359 patent are presumed valid.

169. In view of the foregoing facts and allegations, including paragraphs 70-128 above, Quanta has directly infringed one or more claims of the '359 patent in violation of 35 U.S.C. § 271(a) by making, using, selling, offering to sell, and/or importing the Accused Quanta Products.

170. Quanta's infringement of the '359 patent through its manufacture, use, offers to sell, and/or sales in, and/or importation into, the United States of the Accused Quanta Laptops is shown by way of the exemplary laptop, the MacBook Pro (13-inch, 2017) laptop as set forth in paragraphs 84-98 above, which demonstrates infringement of at least claim 6 of the '359 patent by showing:

- (a) the exemplary laptop is a computer;
- (b) the exemplary laptop has a variety of connectors configured to couple to a console, including USB-C ports;
- (c) the exemplary laptop has a central processing unit (CPU), because the exemplary laptop uses a 7th Generation Intel® Core™ i5 ("Kaby Lake") Processor;
- (d) the exemplary laptop has a first LVDS channel directly extending from the CPU, comprising a first unidirectional, differential signal line pair to convey data in a first direction and a second unidirectional, differential signal line pair to convey data in a second, opposite direction, because the 7th Generation Intel® Core™ i5 ("Kaby

Lake”) Processors employed in the exemplary laptop include, for example, PCIe and USB 3.x channels directly extending from them; and

- (e) the exemplary laptop has a second LVDS channel that can couple to a console through one or more USB-C ports, which use two sets of unidirectional, differential signal pairs to convey USB protocol data packets in opposite directions.

171. On information and belief, the Accused Quanta Laptops are in relevant part substantially similar to the exemplary laptop, in particular with regard to the manner in which the Accused Quanta Laptops include and utilize PCIe and/or USB 3.x functionality. This Section is thus illustrative of the manner in which Quanta infringes the claims of the ’359 patent as to each of the Accused Quanta Laptops.

172. ACQIS’ infringement allegations against the Accused Quanta Laptops are not limited to claim 6 of the ’359 patent, and additional infringed claims will be identified through infringement contentions and discovery.

173. Quanta’s infringement of the ’359 patent through its manufacture, use, offers to sell, and/or sales in, and/or importation into, the United States of the Accused Quanta Desktops is shown by way of the exemplary desktop, the iMac (21.5-inch, 2017) as set forth in paragraphs 99-113 above, which demonstrates infringement of at least claim 6 of the ’359 patent by showing:

- (a) the exemplary desktop is a computer;
- (b) the exemplary desktop has a variety of connectors configured to couple to a console, including USB-C ports;
- (c) the exemplary desktop has a central processing unit (CPU), because the exemplary desktop uses a 7th Generation Intel® Core™ i5 (“Kaby Lake”) Processor;
- (d) the exemplary desktop has a first LVDS channel directly extending from the CPU,

comprising a first unidirectional, differential signal line pair to convey data in a first direction and a second unidirectional, differential signal line pair to convey data in a second, opposite direction, because the 7th Generation Intel® Core™ i5 (“Kaby Lake”) Processors employed in the exemplary desktop include, for example, PCIe and USB 3.x channels directly extending from them; and

- (e) the exemplary desktop has a second LVDS channel that can couple to a console through one or more USB-C ports, which use two sets of unidirectional, differential signal pairs to convey USB protocol data packets in opposite directions.

174. On information and belief, the Accused Quanta Desktops are in relevant part substantially similar to the exemplary desktop, in particular with regard to the manner in which the Accused Quanta Desktops include and utilize PCIe and/or USB 3.x functionality. This Section is thus illustrative of the manner in which Quanta infringes the claims of the ’359 patent as to each of the Accused Quanta Desktops.

175. ACQIS’ infringement allegations against the Accused Quanta Desktops are not limited to claim 6 of the ’359 patent, and additional infringed claims will be identified through infringement contentions and discovery.

176. Quanta’s infringement of the ’359 patent through its manufacture, use, offers to sell, and/or sales in, and/or importation into, the United States of the Accused Quanta Servers is shown by way of the exemplary QuantaGrid D51B-1U server as set forth in paragraphs 114-128 above, which demonstrates infringement of at least claim 6 of the ’359 patent by showing:

- (a) the QuantaGrid D51B-1U is a computer;
- (b) the QuantaGrid D51B-1U has a variety of connectors configured to couple to a console, including USB 3.x ports;

- (c) the QuantaGrid D51B-1U has a central processing unit (CPU), because the QuantaGrid D51B-1U uses Intel® Xeon processors;
- (d) the QuantaGrid D51B-1U has an LVDS channel directly extending from the CPU, comprising a first unidirectional, differential signal line pair to convey data in a first direction and a second unidirectional, differential signal line pair to convey data in a second, opposite direction, because the Intel® Xeon processors employed in the QuantaGrid D51B-1U include, for example, PCIe channels directly extending from them; and
- (e) the QuantaGrid D51B-1U has a second LVDS channel that can couple to a console through one or more USB 3.x ports, which use two sets of unidirectional, differential signal pairs to convey USB protocol data packets in opposite directions.

177. On information and belief, the Accused Quanta Servers are in relevant part substantially similar to the exemplary QuantaGrid products, in particular with regard to the manner in which the Accused Quanta Servers include and utilize PCIe and/or USB 3.x functionality. This Section is thus illustrative of the manner in which Quanta infringes the claims of the '359 patent as to each of the Accused Quanta Servers.

178. ACQIS' infringement allegations against the Accused Quanta Servers are not limited to claim 6 of the '359 patent, and additional infringed claims will be identified through infringement contentions and discovery.

179. As early as around May 14, 2018, Quanta had actual notice of the '359 patent and the infringement alleged herein.

180. The above-described acts of infringement committed by Quanta have caused injury and damage to ACQIS and ACQIS' licensees.

181. ACQIS is entitled to recover all damages sustained as a result of Quanta's wrongful acts of infringement, but in no event less than a reasonable royalty pursuant to 35 U.S.C. § 284.

182. Quanta's infringement as described herein has been willful and exceptional. Accordingly, ACQIS is entitled to recover enhanced damages up to three times the amount found or assessed at trial pursuant to 35 U.S.C. § 284, as well as its attorneys' fees pursuant to 35 U.S.C. § 285.

COUNT IV
INFRINGEMENT OF U.S. PATENT NO. 8,626,977

183. ACQIS incorporates by this reference the allegations set forth in paragraphs 1-134 of this Complaint in support of its third cause of action as though fully set forth herein.

184. Pursuant to 35 U.S.C. § 282, the claims of the '977 patent are presumed valid.

185. In view of the foregoing facts and allegations, including paragraphs 70-113 above, Quanta has directly infringed one or more claims of the '977 patent in violation of 35 U.S.C. § 271(a) by making, using, selling, offering to sell, and/or importing the Quanta Accused Quanta Laptops and Accused Quanta Desktops.

186. Quanta's infringement of the '977 patent through its manufacture, use, offers to sell, and/or sales in, and/or importation into, the United States of the Accused Quanta Laptops is shown by way of the exemplary laptop, the MacBook Pro (13-inch, 2017) laptop as set forth in paragraphs 84-98 above, which demonstrates infringement of at least claim 1 of the '977 patent by showing:

- (a) the exemplary laptop is a computer;
- (b) the exemplary laptop has a variety of connectors configured to couple to a console, including USB-C ports;
- (c) the exemplary laptop has an integrated central processing unit (CPU) and graphics

subsystem in a single chip, because the exemplary laptop uses a 7th Generation Intel® Core™ i5 (“Kaby Lake”) Processor, which includes a graphics subsystem and the CPU integrated as a single chip;

- (d) the exemplary laptop has an LVDS channel directly extending from the CPU using two sets of unidirectional, differential signal line pairs to transmit encoded address and data bits of a PCI bus transaction in a serial bit stream in opposite directions, because the 7th Generation Intel® Core™ i5 (“Kaby Lake”) Processors employed in the exemplary laptop include, for example, PCIe channels directly extending from the CPU
- (e) the exemplary laptop has serial bit channels coupled to the USB-C 3.x that are adapted to convey USB protocol data packets in opposite directions; and
- (f) the 7th Generation Intel® Core™ i5 (“Kaby Lake”) Processors employed in the exemplary laptop output digital video display signals through DDI and/or eDP channels.

187. On information and belief, the Accused Quanta Laptops are in relevant part substantially similar to the exemplary laptop, in particular with regard to the manner in which the Accused Quanta Laptops include and utilize PCIe and/or USB 3.x functionality. This Section is thus illustrative of the manner in which Quanta infringes the claims of the '977 patent as to each of the Accused Quanta Laptops.

188. ACQIS' infringement allegations against the Accused Quanta Laptops are not limited to claim 1 of the '977 patent, and additional infringed claims will be identified through infringement contentions and discovery.

189. Quanta's infringement of the '977 patent through its manufacture, use, offers to sell, and/or sales in, and/or importation into, the United States of the Accused Quanta Desktops is shown by way of the exemplary desktop, the iMac (21.5-inch, 2017) desktop as set forth in paragraphs 99-113 above, which demonstrates infringement of at least claim 1 of the '977 patent by showing:

- (a) the exemplary desktop is a computer;
- (b) the exemplary desktop has a variety of connectors configured to couple to a console, including USB-C ports;
- (c) the exemplary desktop has an integrated central processing unit (CPU) and graphics subsystem in a single chip, because the exemplary desktop uses a 7th Generation Intel® Core™ i5 ("Kaby Lake") Processor, which includes a graphics subsystem and the CPU integrated as a single chip;
- (d) the exemplary desktop has an LVDS channel directly extending from the CPU using two sets of unidirectional, differential signal line pairs to transmit encoded address and data bits of a PCI bus transaction in a serial bit stream in opposite directions, because the 7th Generation Intel® Core™ i5 ("Kaby Lake") Processors employed in the exemplary desktop include, for example, PCIe channels directly extending from the CPU;
- (e) the exemplary desktop has serial bit channels coupled to the USB-C ports that are adapted to convey USB protocol data packets in opposite directions; and
- (f) the 7th Generation Intel® Core™ i5 ("Kaby Lake") Processors employed in the exemplary desktop outputs digital video display signals through DDI and/or eDP channels.

190. On information and belief, the Accused Quanta Desktops are in relevant part substantially similar to the exemplary desktop, in particular with regard to the manner in which the Accused Quanta Desktops include and utilize PCIe and/or USB 3.x functionality. This Section is thus illustrative of the manner in which Quanta infringes the claims of the '977 patent as to each of the Accused Quanta Desktops.

191. ACQIS' infringement allegations against the Accused Quanta Desktops are not limited to claim 1 of the '977 patent, and additional infringed claims will be identified through infringement contentions and discovery.

192. As early as around May 14, 2018, Quanta had actual notice of the '977 patent and the infringement alleged herein.

193. The above-described acts of infringement committed by Quanta have caused injury and damage to ACQIS and ACQIS' licensees.

194. ACQIS is entitled to recover all damages sustained as a result of Quanta's wrongful acts of infringement, but in no event less than a reasonable royalty pursuant to 35 U.S.C. § 284.

195. Quanta's infringement as described herein has been willful and exceptional. Accordingly, ACQIS is entitled to recover enhanced damages up to three times the amount found or assessed at trial pursuant to 35 U.S.C. § 284, as well as its attorneys' fees pursuant to 35 U.S.C. § 285.

COUNT V
INFRINGEMENT OF U.S. PATENT NO. RE44,739

196. ACQIS incorporates by this reference the allegations set forth in paragraphs 1-134 of this Complaint in support of its third cause of action as though fully set forth herein.

197. Pursuant to 35 U.S.C. § 282, the claims of the '739 patent are presumed valid.

198. In view of the foregoing facts and allegations, including paragraphs 70-113 above, Quanta has directly infringed infringe one or more claims of the '739 patent in violation of 35 U.S.C. § 271(a) by making, using, selling, offering to sell, and/or importing the Quanta Accused Quanta Laptops and Accused Quanta Desktops.

199. Quanta's infringement of the '739 patent through its manufacture, use, offers to sell, and/or sales in, and/or importation into, the United States of the Accused Quanta Laptops is shown by way of the exemplary laptop, the MacBook Pro (13-inch, 2017) laptop as set forth in paragraphs 84-98 above, which demonstrates infringement of at least claim 18 of the '739 patent by showing:

- (a) the exemplary laptop is a computer;
- (b) the exemplary laptop has an integrated central processing unit (CPU) and graphics controller in a single chip directly coupled to a first differential signal channel to convey digital video display information, because the 7th Generation Intel® Core™ i5 (“Kaby Lake”) Processors employed in the exemplary laptop is directly coupled to one or more differential signal channels to convey digital signals, including eDP and/or DDI channels;
- (c) the exemplary laptop has a second LVDS channel with at least two pairs of unidirectional, differential signal lanes to transmit data in opposite directions, including USB 3.x channels;
- (d) the exemplary laptop has a variety of connectors configured to couple to a console, including USB-C ports; and
- (e) upon coupling to a console, the second LVDS channel in the exemplary laptop transmits USB protocol data through the USB-C ports.

200. On information and belief, the Accused Quanta Laptops are in relevant part substantially similar to the exemplary laptop, in particular with regard to the manner in which the Accused Quanta Laptops include and utilize PCIe and/or USB 3.x functionality. This Section is thus illustrative of the manner in which Quanta infringes the claims of the '739 patent as to each of the Accused Quanta Laptops.

201. ACQIS' infringement allegations against the Accused Quanta Laptops are not limited to claim 18 of the '739 patent, and additional infringed claims will be identified through infringement contentions and discovery.

202. Quanta's infringement of the '739 patent through its manufacture, use, offers to sell, and/or sales in, and/or importation into, the United States of the Accused Quanta Desktops is shown by way of the exemplary desktop, the iMac (21.5-inch, 2017) desktop as set forth in paragraphs 99-113 above, which demonstrates infringement of at least claim 18 of the '739 patent by showing:

- (a) the exemplary desktop is a computer;
- (b) the exemplary desktop has an integrated central processing unit (CPU) and graphics controller in a single chip directly coupled to a first differential signal channels to convey digital video display information, because the 7th Generation Intel® Core™ i5 ("Kaby Lake") Processors employed in the exemplary desktop is directly coupled to one or more differential signal channels to convey digital signals, including eDP and/or DDI channels;
- (c) the exemplary desktop has a second LVDS channel with at least two pairs of unidirectional, differential signal lanes to transmit data in opposite directions, including USB 3.x channels;

(d) the exemplary desktop has a variety of connectors configured to couple to a console, including USB 3.x ports; and

(e) upon coupling to a console, the second LVDS channel in the exemplary desktop transmits USB protocol data through the USB 3.x ports

203. On information and belief, the Accused Quanta Desktops are in relevant part substantially similar to the exemplary desktop, in particular with regard to the manner in which the Accused Quanta Desktops include and utilize PCIe and/or USB 3.x functionality. This Section is thus illustrative of the manner in which Quanta infringes the claims of the '739 patent as to each of the Accused Quanta Desktops.

204. ACQIS' infringement allegations against the Accused Quanta Desktops are not limited to claim 18 of the '739 patent, and additional infringed claims will be identified through infringement contentions and discovery.

205. As early as around May 14, 2018, Quanta had actual notice of the '739 patent and the infringement alleged herein.

206. The above-described acts of infringement committed by Quanta have caused injury and damage to ACQIS and ACQIS' licensees.

207. ACQIS is entitled to recover all damages sustained as a result of Quanta's wrongful acts of infringement, but in no event less than a reasonable royalty pursuant to 35 U.S.C. § 284.

208. Quanta's infringement as described herein has been willful and exceptional. Accordingly, ACQIS is entitled to recover enhanced damages up to three times the amount found or assessed at trial pursuant to 35 U.S.C. § 284, as well as its attorneys' fees pursuant to 35 U.S.C. § 285.

COUNT VI
INFRINGEMENT OF U.S. PATENT NO. 8,977,797

209. ACQIS incorporates by this reference the allegations set forth in paragraphs 1-134 of this Complaint in support of its third cause of action as though fully set forth herein.

210. Pursuant to 35 U.S.C. § 282, the claims of the '797 patent are presumed valid.

211. In view of the foregoing facts and allegations, including paragraphs 70-128 above, Quanta has directly infringed one or more claims of the '797 patent in violation of 35 U.S.C. § 271(g) by importing into, or selling, offering to sell, or using in, the United States the Accused Quanta Products that were manufactured by one or more of the methods claimed in the '797 patent.

212. The Accused Quanta Products are not trivial or nonessential components of other products and are not materially changed by subsequent processes.

213. Quanta's infringement of the '797 patent through its importation into, and/or use, offers to sell, or sales in, the United States of the Accused Quanta Laptops is shown by way of the exemplary laptop, the MacBook Pro (13-inch, 2017) laptop as set forth in paragraphs 84-98 above. These paragraphs demonstrate that the exemplary laptop was necessarily manufactured according to at least claim 36 of the '797 patent:

- (a) Quanta or another party performs a method of improving data throughput on a motherboard when manufacturing the exemplary laptop, which contains a motherboard;
- (b) when manufacturing the exemplary laptop, Quanta or another party mounts an integrated CPU and interface controller as a single chip on the motherboard, because the Intel processor employed in the exemplary laptop includes interface controllers (*e.g.*, to drive/control PCIe channels) and the CPU integrated as a single chip;
- (c) when manufacturing the exemplary laptop, Quanta or another party connects an LVDS channel directly to an interface controller integrated with the CPU, which

LVDS channel uses two unidirectional, serial channels to transmit data in opposite directions because the exemplary laptop has PCIe channels and an OPI interface directly connected to the interface controller;

- (d) when manufacturing the exemplary laptop, Quanta or another party increases data throughput in the serial channels by providing each channel with multiple differential signal line pairs, because the PCIe and OPI channels have multiple pairs of differential signal lanes;
- (e) when manufacturing the exemplary laptop, Quanta or another party configures the interface controller to adapt to different numbers of differential signal line pairs to convey encoded address and data bits of a PCI bus transaction in serial form, because the interface controller integrated with the CPU are configured to convey PCIe data signals through PCIe channels having differential signal line pairs; and
- (f) when manufacturing the exemplary laptop, Quanta or another party couples the integrated CPU and interface device to a peripheral device such as a mass storage device, which is attached to the motherboard through a PCIe channel.

214. On information and belief, the Accused Quanta Laptops are in relevant part substantially similar to the exemplary laptop, in particular with regard to the manner in which the Accused Quanta Laptops include and utilize PCIe and/or USB 3.x functionality. This Section is thus illustrative of the manner in which Quanta infringes the claims of the '797 patent as to each of the Accused Quanta Laptops.

215. ACQIS' infringement allegations against the Accused Quanta Laptops are not limited to claim 36 of the '797 patent, and additional infringed claims will be identified through infringement contentions and discovery.

216. Quanta's infringement of the '797 patent through its importation into, and/or use, offers to sell, or sales in, the United States of the Accused Quanta Desktops is shown by way of the exemplary desktop, the iMac (21.5-inch, 2017) desktop as set forth in paragraphs 99-113 above. These paragraphs demonstrate that the exemplary desktop was necessarily manufactured according to at least claim 36 of the '797 patent:

- (a) Quanta or another party performs a method of improving data throughput on a motherboard when manufacturing the exemplary desktop, which contains a motherboard;
- (b) when manufacturing the exemplary desktop, Quanta or another party mounts an integrated CPU and interface controller as a single chip on the motherboard, because the Intel processor employed in the exemplary desktop includes interface controllers (*e.g.*, to drive/control PCIe channels) and the CPU integrated as a single chip;
- (c) when manufacturing the exemplary desktop, Quanta or another party connects an LVDS channel directly to an interface controller integrated with the CPU, which LVDS channel uses two unidirectional, serial channels to transmit data in opposite directions because the exemplary desktop has PCIe channels and a OPI interface directly connected to the interface controller;
- (d) when manufacturing the exemplary desktop, Quanta or another party increases data throughput in the serial channels by providing each channel with multiple differential signal line pairs, because the PCIe and OPI channels have multiple pairs of differential signal lanes;
- (e) when manufacturing the exemplary desktop, Quanta or another party configures the interface controller to adapt to different numbers of differential signal line pairs to

convey encoded address and data bits of a PCI bus transaction in serial form, because the interface controller integrated with the CPU are configured to convey PCIe data signals through PCIe channels having differential signal line pairs; and

- (f) when manufacturing the exemplary desktop, Quanta or another party couples the integrated CPU and interface device to a peripheral device such as a mass storage device, which is attached to the motherboard through a PCIe channel.

217. On information and belief, the Accused Quanta Desktops are in relevant part substantially similar to the exemplary desktop, in particular with regard to the manner in which the Accused Quanta Desktops include and utilize PCIe and/or USB 3.x functionality. This Section is thus illustrative of the manner in which Quanta infringes the claims of the '797 patent as to each of the Accused Quanta Desktops.

218. ACQIS' infringement allegations against the Accused Quanta Desktops are not limited to claim 36 of the '797 patent, and additional infringed claims will be identified through infringement contentions and discovery.

219. Quanta's infringement of the '797 patent through its importation into, and/or use, offers to sell, or sales in, the United States of the Accused Quanta Servers is shown by way of the exemplary QuantaGrid D51B-1U server as set forth in paragraphs 114-128 above. These paragraphs demonstrate that the QuantaGrid D51B-1U server was necessarily manufactured according to at least claim 36 of the '797 patent:

- (a) Quanta or another party performs a method of improving data throughput on a motherboard when manufacturing the QuantaGrid D51B-1U, which contains a motherboard;
- (b) when manufacturing the QuantaGrid D51B-1U, Quanta or another party mounts an

integrated CPU and interface controller as a single chip on the motherboard, because the Intel processor employed in the QuantaGrid D51B-1U includes interface controllers (*e.g.*, to drive/control PCIe channels) and the CPU integrated as a single chip;

- (c) when manufacturing the QuantaGrid D51B-1U, Quanta or another party connects an LVDS channel directly to an interface controller integrated with the CPU, which LVDS channel uses two unidirectional, serial channels to transmit data in opposite directions because the QuantaGrid D51B-1U has PCIe channels and a DMI interface directly connected to the interface controller;
- (d) when manufacturing the QuantaGrid D51B-1U, Quanta or another party increases data throughput in the serial channels by providing each channel with multiple differential signal line pairs, because the PCIe and DMI channels have multiple pairs of differential signal lanes;
- (e) when manufacturing the QuantaGrid D51B-1U, Quanta or another party configures the interface controller to adapt to different numbers of differential signal line pairs to convey encoded address and data bits of a PCI bus transaction in serial form, because the interface controllers integrated with the CPU are configured to convey PCIe data signals through PCIe channels having differential signal line pairs; and
- (f) when manufacturing the QuantaGrid D51B-1U, Quanta or another party couples the integrated CPU and interface device to a peripheral device such as a storage interface controller or a graphics processor, which is attached to the motherboard through a PCIe channel.

220. ACQIS' infringement allegations against the Accused Quanta Servers are not limited to claim 7 of the '797 patent, and additional infringed claims will be identified through infringement contentions and discovery.

221. As early as around May 14, 2018, Quanta had actual notice of the '797 patent and the infringement alleged herein.

222. The above-described acts of infringement committed by Quanta have caused injury and damage to ACQIS and ACQIS' licensees.

223. ACQIS is entitled to recover all damages sustained as a result of Quanta's wrongful acts of infringement, but in no event less than a reasonable royalty pursuant to 35 U.S.C. § 284.

224. Quanta's infringement as described herein has been willful and exceptional. Accordingly, ACQIS is entitled to recover enhanced damages up to three times the amount found or assessed at trial pursuant to 35 U.S.C. § 284, as well as its attorneys' fees pursuant to 35 U.S.C. § 285.

COUNT VII
INFRINGEMENT OF U.S. PATENT NO. 9,529,769

225. ACQIS incorporates by this reference the allegations set forth in paragraphs 1-134 of this Complaint in support of its third cause of action as though fully set forth herein.

226. Pursuant to 35 U.S.C. § 282, the claims of the '769 patent are presumed valid.

227. In view of the foregoing facts and allegations, including paragraphs 70-128 above, Quanta has directly infringed one or more claims of the '769 patent in violation of 35 U.S.C. § 271(g) by importing into, or selling, offering to sell, or using in, the United States the Accused Quanta Products that were manufactured by one or more of the methods claimed in the '769 patent.

228. The Accused Quanta Products are not trivial or nonessential components of other products and are not materially changed by subsequent processes.

229. Quanta's infringement of the '769 patent through its importation into, and/or use, offers to sell, or sales in, the United States of the Accused Quanta Laptops is shown by way of the exemplary laptop, the MacBook Pro (13-inch, 2017) laptop as set forth in paragraphs 84-98 above. These paragraphs demonstrate that the exemplary laptop was necessarily manufactured according to at least claim 19 of the '769 patent:

- (a) Quanta or another party performs a method of improving external peripheral data communication in a computer when manufacturing the exemplary laptop;
- (b) when manufacturing the exemplary laptop, Quanta or another party obtains an integrated CPU and graphics controller as a single chip, because the exemplary laptop uses a 7th Generation Intel® Core™ i5 (“Kaby Lake”) Processor;
- (c) when manufacturing the exemplary laptop, Quanta or another party connects a unidirectional signal channel directly to the integrated CPU and graphics controller to output digital video data, because the 7th Generation Intel® Core™ i5 (“Kaby Lake”) Processors employed in the exemplary laptop directly connect to eDP and/or DDI channels;
- (d) when manufacturing the exemplary laptop, Quanta or another party provides a connector for external peripheral data communication, because the exemplary laptop has a variety of connectors for external peripherals, including USB-C connectors;
- (e) when manufacturing the exemplary laptop, Quanta or another party provides an LVDS channel to convey USB protocol data through a connector that uses two unidirectional, serial bit channels that transmit data in opposite directions, because the exemplary laptop has a USB-C connector that conveys USB 3.x data; and
- (f) when manufacturing the exemplary laptop, Quanta or another party provides a second

LVDS channel to convey digital video data through a connector, because the exemplary laptop has a USB-C port that can convey/output DisplayPort and Thunderbolt digital video data signals.

230. On information and belief, the Accused Quanta Laptops are in relevant part substantially similar to the exemplary laptop, in particular with regard to the manner in which the Accused Quanta Laptops include and utilize PCIe and/or USB 3.x functionality. This Section is thus illustrative of the manner in which Quanta infringes the claims of the '769 patent as to each of the Accused Quanta Laptops.

231. ACQIS' infringement allegations against the Accused Quanta Laptops are not limited to claim 19 of the '769 patent, and additional infringed claims will be identified through infringement contentions and discovery.

232. Quanta's infringement of the '769 patent through its importation into, and/or use, offers to sell, or sales in, the United States of the Accused Quanta Desktops is shown by way of the exemplary desktop, the iMac (21.5-inch, 2017) desktop as set forth in paragraphs 99-113 above. These paragraphs demonstrate that the exemplary desktop was necessarily manufactured according to at least claim 19 of the '769 patent:

- (a) Quanta or another party performs a method of improving external peripheral data communication in a computer when manufacturing the exemplary desktop;
- (b) when manufacturing the exemplary desktop, Quanta or another party obtains an integrated CPU and graphics controller as a single chip, because the exemplary desktop uses a 7th Generation Intel® Core™ i5 (“Kaby Lake”) Processor;
- (c) when manufacturing the exemplary desktop, Quanta or another party connects a unidirectional signal channel directly to the integrated CPU and graphics controller to

output digital video data, because the 7th Generation Intel® Core™ i5 (“Kaby Lake”) Processors employed in the exemplary desktop connect directly to eDP and/or DDI channels;

- (d) when manufacturing the exemplary desktop, Quanta or another party provides a connector for external peripheral data communication, because the exemplary desktop has a variety of connectors for external peripherals, including USB-C ports;
- (e) when manufacturing the exemplary desktop, Quanta or another party provides an LVDS channel to convey USB protocol data through a connector that uses two unidirectional, serial bit channels that transmit data in opposite directions, because the exemplary desktop has a USB-C connector that conveys USB 3.x data; and
- (f) when manufacturing the exemplary desktop, Quanta or another party provides a second LVDS channel to convey digital video data through a connector, because the exemplary desktop has a USB-C port that can convey/output DisplayPort and Thunderbolt digital video data signals.

233. On information and belief, the Accused Quanta Desktops are in relevant part substantially similar to the exemplary desktop, in particular with regard to the manner in which the Accused Quanta Desktops include and utilize PCIe and/or USB 3.x functionality. This Section is thus illustrative of the manner in which Quanta infringes the claims of the ’769 patent as to each of the Accused Quanta Desktops.

234. ACQIS’ infringement allegations against the Accused Quanta Desktops are not limited to claim 19 of the ’769 patent, and additional infringed claims will be identified through infringement contentions and discovery.

235. As early as around May 14, 2018, Quanta had actual notice of the '769 patent and the infringement alleged herein.

236. The above-described acts of infringement committed by Quanta have caused injury and damage to ACQIS and ACQIS' licensees.

237. ACQIS is entitled to recover all damages sustained as a result of Quanta's wrongful acts of infringement, but in no event less than a reasonable royalty pursuant to 35 U.S.C. § 284.

238. Quanta's infringement as described herein has been willful and exceptional. Accordingly, ACQIS is entitled to recover enhanced damages up to three times the amount found or assessed at trial pursuant to 35 U.S.C. § 284, as well as its attorneys' fees pursuant to 35 U.S.C. § 285.

COUNT VIII
INFRINGEMENT OF U.S. PATENT NO. RE45,140

239. ACQIS incorporates by this reference the allegations set forth in paragraphs 1-134 of this Complaint in support of its third cause of action as though fully set forth herein.

240. Pursuant to 35 U.S.C. § 282, the claims of the '140 patent are presumed valid.

241. In view of the foregoing facts and allegations, including paragraphs 70-128 above, Quanta has directly infringed one or more claims of the '140 patent in violation of 35 U.S.C. § 271(g) by importing into, or selling, offering to sell, or using in, the United States the Accused Quanta Products that were manufactured by one or more of the methods claimed in the '140 patent.

242. The Accused Quanta Products are not trivial or nonessential components of other products and are not materially changed by subsequent processes.

243. Quanta's infringement of the '140 patent through its importation into, and/or use, offers to sell, or sales in, the United States of the Accused Quanta Laptops is shown by way of the exemplary laptop, the MacBook Pro (13-inch, 2017) laptop as set forth in paragraphs 84-98 above.

These paragraphs demonstrate that the exemplary laptop was necessarily manufactured according to at least claim 35 of the '140 patent:

- (a) Quanta or another party performs a method of improving performance of a computer when manufacturing the exemplary laptop;
- (b) when manufacturing the exemplary laptop, Quanta or another party obtains an integrated CPU and graphics controller as a single chip, because the exemplary laptop uses a 7th Generation Intel® Core™ i5 (“Kaby Lake”) Processor;
- (c) when manufacturing the exemplary laptop, Quanta or another party connects an LVDS channel directly to the integrated CPU and graphics controller that uses two unidirectional, serial bit channels to transmit data in opposite directions, because the 7th Generation Intel® Core™ i5 (“Kaby Lake”) Processors employed in the exemplary laptop directly connect to PCIe and OPI channels;
- (d) when manufacturing the exemplary laptop, Quanta or another party connects a differential signal channel directly to the integrated CPU and graphics controller to output digital video data, because the 7th Generation Intel® Core™ i5 (“Kaby Lake”) Processors employed in the exemplary laptop connect to DDI and/or eDP channels;
- (e) when manufacturing the exemplary laptop, Quanta or another party provides a connector for external peripheral data communication, because the exemplary laptop has a variety of connectors for external peripherals, including USB-C ports; and
- (f) when manufacturing the exemplary laptop, Quanta or another party provides a second LVDS channel using two unidirectional, serial bit channels to transmit data in opposite directions through the connector, because the exemplary laptop has USB-C

connectors capable of supporting USB3.x and Thunderbolt.

244. On information and belief, the Accused Quanta Laptops are in relevant part substantially similar to the exemplary laptop, in particular with regard to the manner in which the Accused Quanta Laptops include and utilize PCIe and/or USB 3.x functionality. This Section is thus illustrative of the manner in which Quanta infringes the claims of the '140 patent as to each of the Accused Quanta Laptops.

245. ACQIS' infringement allegations against the Accused Quanta Laptops are not limited to claim 35 of the '140 patent, and additional infringed claims will be identified through infringement contentions and discovery.

246. Quanta's infringement of the '140 patent through its importation into, and/or use, offers to sell, or sales in, the United States of the Accused Quanta Desktops is shown by way of the exemplary desktop, the iMac (21.5-inch, 2017) desktop as set forth in paragraphs 99-113 above. These paragraphs demonstrate that the exemplary desktop was necessarily manufactured according to at least claim 35 of the '140 patent:

- (a) Quanta or another party performs a method of improving performance of a computer when manufacturing the exemplary desktop;
- (b) when manufacturing the exemplary desktop, Quanta or another party obtains an integrated CPU and graphics controller as a single chip, because the exemplary desktop uses a 7th Generation Intel® Core™ i5 ("Kaby Lake") Processor;
- (c) when manufacturing the exemplary desktop, Quanta or another party connects an LVDS channel directly to the integrated CPU and graphics controller that uses two unidirectional, serial bit channels to transmit data in opposite directions, because the 7th Generation Intel® Core™ i5 ("Kaby Lake") Processors employed in the

exemplary desktop directly connect to PCIe and OPI channels;

- (d) when manufacturing the exemplary desktop, Quanta or another party connects a differential signal channel directly to the integrated CPU and graphics controller to output digital video data, because the 7th Generation Intel® Core™ i5 (“Kaby Lake”) Processors employed in the exemplary desktop connect to DDI and/or eDP channels;
- (e) when manufacturing the exemplary desktop, Quanta or another party provides a connector for external peripheral data communication, because the exemplary desktop has a variety of connectors for external peripherals, including USB-C ports; and
- (f) when manufacturing the exemplary desktop, Quanta or another party provides a second LVDS channel using two unidirectional, serial bit channels to transmit data in opposite directions through the connector, because the exemplary desktop has USB-C capable of supporting USB 3.x and Thunderbolt.

247. On information and belief, the Accused Quanta Desktops are in relevant part substantially similar to the exemplary desktop, in particular with regard to the manner in which the Accused Quanta Desktops include and utilize PCIe and/or USB 3.x functionality. This Section is thus illustrative of the manner in which Quanta infringes the claims of the ’140 patent as to each of the Accused Quanta Desktops.

248. ACQIS’ infringement allegations against the Accused Quanta Desktops are not limited to claim 35 of the ’140 patent, and additional infringed claims will be identified through infringement contentions and discovery.

249. As early as around May 14, 2018, Quanta had actual notice of the '140 patent and the infringement alleged herein.

250. The above-described acts of infringement committed by Quanta have caused injury and damage to ACQIS and ACQIS' licensees.

251. ACQIS is entitled to recover all damages sustained as a result of Quanta's wrongful acts of infringement, but in no event less than a reasonable royalty pursuant to 35 U.S.C. § 284.

252. Quanta's infringement as described herein has been willful and exceptional. Accordingly, ACQIS is entitled to recover enhanced damages up to three times the amount found or assessed at trial pursuant to 35 U.S.C. § 284, as well as its attorneys' fees pursuant to 35 U.S.C. § 285.

COUNT IX
INFRINGEMENT OF U.S. PATENT NO. RE44,654

253. ACQIS incorporates by this reference the allegations set forth in paragraphs 1-134 of this Complaint in support of its third cause of action as though fully set forth herein.

254. Pursuant to 35 U.S.C. § 282, the claims of the '654 patent are presumed valid.

255. In view of the foregoing facts and allegations, including paragraphs 70-128 above, Quanta has directly infringed one or more claims of the '654 patent in violation of 35 U.S.C. § 271(g) by using one or more of the methods claimed in the '654 patent to manufacture the Accused Quanta Products and then importing, selling, offering to sell and/or using the Accused Quanta Products in the United States.

256. The Accused Quanta Products made using the methods claimed in the '654 patent are not trivial or nonessential components of other products and are not materially changed by subsequent processes.

257. Quanta's infringement of the '654 patent through its importation into, and/or use, offers to sell, or sales in, the United States of the Accused Quanta Laptops is shown by way of the exemplary laptop, the MacBook Pro (13-inch, 2017) laptop as set forth in paragraphs 84-98 above. These paragraphs demonstrate that the exemplary laptop was necessarily manufactured according to at least claim 23 of the '654 patent:

- (a) Quanta or another party performs a method of increasing data communication speed of a computer when manufacturing the exemplary laptop;
- (b) when manufacturing the exemplary laptop, Quanta or another party connects a CPU directly to a peripheral bridge on a printed circuit board, because the exemplary laptop uses an Intel core CPU directly connected to the Intel PCH via an OPI connection;
- (c) when manufacturing the exemplary laptop, Quanta or another party connects an LVDS channel directly to the peripheral bridge (PCH), which uses two unidirectional, serial channels to transmit data in opposite directions, because the exemplary laptop has PCIe channels and OPI channels directly connected to the Intel PCH;
- (d) when manufacturing the exemplary laptop, Quanta or another party provides a connector to connect the computer to a console, because the exemplary laptop has a variety of connector ports USB-Cx;
- (e) when manufacturing the exemplary laptop, Quanta or another party provides a second LVDS channel using two unidirectional, serial channels to transmit data in opposite directions through the connector to the console, because the exemplary laptop has USB-C ports capable of supporting USB 3.x and Thunderbolt; and
- (f) when manufacturing the exemplary laptop, Quanta or another party enables the transmission of USB protocol data through the second LVDS channel via a USB 3.x

channel and USB-C port.

258. On information and belief, the Accused Quanta Laptops are in relevant part substantially similar to the exemplary laptop, in particular with regard to the manner in which the Accused Quanta Laptops include and utilize PCIe and/or USB 3.x functionality. This Section is thus illustrative of the manner in which Quanta infringes the claims of the '654 patent as to each of the Accused Quanta Laptops.

259. ACQIS' infringement allegations against the Accused Quanta Laptops are not limited to claim 23 of the '654 patent, and additional infringed claims will be identified through infringement contentions and discovery.

260. Quanta's infringement of the '654 patent through its importation into, and/or use, offers to sell, or sales in, the United States of the Accused Quanta Desktops is shown by way of the exemplary desktop, the iMac (21.5-inch, 2017) desktop as set forth in paragraphs 99-113 above. These paragraphs demonstrate that the exemplary desktop was necessarily manufactured according to at least claim 23 of the '654 patent:

- (a) Quanta or another party performs a method of increasing data communication speed of a computer when manufacturing the exemplary desktop;
- (b) when manufacturing the exemplary desktop, Quanta or another party connects a CPU directly to a peripheral bridge on a printed circuit board, because the exemplary desktop uses an Intel core CPU directly connected to the Intel PCH via an OPI connection;
- (c) when manufacturing the exemplary desktop, Quanta or another party connects an LVDS channel directly to the peripheral bridge (PCH), which uses two unidirectional, serial channels to transmit data in opposite directions, because the exemplary desktop

has PCIe channels and OPI channels directly connected to the Intel PCH;

- (d) when manufacturing the exemplary desktop, Quanta or another party provides a connector to connect the computer to a console, because the exemplary desktop has a variety of connector ports such as USB-C;
- (e) when manufacturing the exemplary desktop, Quanta or another party provides a second LVDS channel using two unidirectional, serial channels to transmit data in opposite directions through the connector to the console, because the exemplary desktop has USB-C ports capable of supporting USB 3.x and Thunderbolt; and
- (f) when manufacturing the exemplary desktop, Quanta or another party enables the transmission of USB protocol data through the second LVDS channel via a USB 3.x channel and USB-C port.

261. On information and belief, the Accused Quanta Desktops are in relevant part substantially similar to the exemplary desktop, in particular with regard to the manner in which the Accused Quanta Desktops include and utilize PCIe and/or USB 3.x functionality. This Section is thus illustrative of the manner in which Quanta infringes the claims of the '654 patent as to each of the Accused Quanta Desktops.

262. ACQIS' infringement allegations against the Accused Quanta Desktops are not limited to claim 23 of the '654 patent, and additional infringed claims will be identified through infringement contentions and discovery.

263. Quanta's infringement of the '654 patent through its importation into, and/or use, offers to sell, or sales in, the United States of the Accused Quanta Servers is shown by way of the exemplary QuantaGrid D51B-1U server as set forth in paragraphs 114-128 above. These

paragraphs demonstrate that the QuantaGrid D51B-1U server was necessarily manufactured according to at least claim 23 of the '654 patent:

- (a) Quanta or another party performs a method of increasing data communication speed of a computer when manufacturing the QuantaGrid D51B-1U;
- (b) when manufacturing the QuantaGrid D51B-1U, Quanta or another party connects a CPU directly to a peripheral bridge on a printed circuit board, because the QuantaGrid D51B-1U uses an Intel core CPU directly connected to the Intel PCH via a DMI connection;
- (c) when manufacturing the QuantaGrid D51B-1U, Quanta or another party connects an LVDS channel directly to the peripheral bridge (PCH), which uses two unidirectional, serial channels to transmit data in opposite directions, because the QuantaGrid D51B-1U has PCIe channels and a DMI channel directly connected to the Intel PCH;
- (d) when manufacturing the QuantaGrid D51B-1U, Quanta or another party provides a connector to connect the computer to a console, because the QuantaGrid D51B-1U has a variety of connector ports such as USB 3.x;
- (e) when manufacturing the QuantaGrid D51B-1U, Quanta or another party provides a second LVDS channel using two unidirectional, serial channels to transmit data in opposite directions through the connector to the console, because the QuantaGrid D51B-1U has USB 3.x ports; and
- (f) when manufacturing the QuantaGrid D51B-1U, Quanta or another party enables the transmission of USB protocol data through the second LVDS channel via a USB 3.x port and channel.

264. On information and belief, the Accused Quanta Servers are in relevant part substantially similar to the exemplary QuantaGrid products, in particular with regard to the manner in which the Accused Quanta Servers include and utilize PCIe and/or USB 3.x functionality. This Section is thus illustrative of the manner in which Quanta infringes the claims of the '654 patent as to each of the Accused Quanta Servers.

265. ACQIS' infringement allegations against the Accused Quanta Servers are not limited to claim 23 of the '654 patent, and additional infringed claims will be identified through infringement contentions and discovery.

266. As early as around May 1, 2018, Quanta had actual notice of the '654 patent and the infringement alleged herein.

267. The above-described acts of infringement committed by Quanta have caused injury and damage to ACQIS and ACQIS' licensees.

268. ACQIS is entitled to recover all damages sustained as a result of Quanta's wrongful acts of infringement, but in no event less than a reasonable royalty pursuant to 35 U.S.C. § 284.

269. Quanta's infringement as described herein has been willful and exceptional. Accordingly, ACQIS is entitled to recover enhanced damages up to three times the amount found or assessed at trial pursuant to 35 U.S.C. § 284, as well as its attorneys' fees pursuant to 35 U.S.C. § 285.

COUNT X
INFRINGEMENT OF U.S. PATENT NO. 8,234,436

270. ACQIS incorporates by this reference the allegations set forth in paragraphs 1-134 of this Complaint in support of its first cause of action as though fully set forth herein.

271. Pursuant to 35 U.S.C. § 282, the claims of the '436 patent are presumed valid.

272. In view of the foregoing facts and allegations, including paragraphs 70-113 above,

Quanta has directly infringed one or more claims of the '436 patent in violation of 35 U.S.C. § 271(a) by making, using, selling, offering to sell, and/or importing the Accused Quanta Products.

273. Quanta's infringement of the '436 patent through its manufacture, use, offers to sell, and/or sales in, and/or importation into, the United States of the Accused Quanta Laptops is shown by way of the exemplary laptop, the MacBook Pro (13-inch, 2017) laptop as set forth in paragraphs 84-98 above, which demonstrates infringement of at least claim 13 of the '436 patent by showing:

- (a) the exemplary laptop is a computer;
- (b) the exemplary laptop has a first LVDS channel comprising at least two sets of unidirectional, multiple serial bit channels to convey data in opposite directions, including but not limited to its PCIe and OPI channels;
- (c) the exemplary laptop has an integrated central processing unit (CPU) with a peripheral controller in a single chip directly coupled to one or more LVDS channels which can communicate encoded address and data bits of Peripheral Component Interconnect (PCI) bus transaction in serial form, because the 7th Generation Intel® Core™ i5 ("Kaby Lake") Processors employed in the exemplary laptop are directly coupled to at least PCIe and OPI channels;
- (d) the exemplary laptop has system memory directly coupled to the integrated CPU and interface controller, because the the 7th Generation Intel® Core™ i5 ("Kaby Lake") Processors employed in the exemplary laptop are directly coupled to DDR3 memory;
- (e) the exemplary laptop has a mass storage device coupled to the CPU, because the 7th Generation Intel® Core™ i5 ("Kaby Lake") Processors employed in the

exemplary laptop are coupled to the SSD; and

- (f) the exemplary laptop has a second LVDS channel which conveys digital video data that are directly coupled to the integrated CPU with graphics controller, because the 7th Generation Intel® Core™ i5 (“Kaby Lake”) Processors employed in the exemplary laptop are directly coupled to eDP and/or DDI channels.

274. On information and belief, the Accused Quanta Laptops are in relevant part substantially similar to the exemplary laptop, in particular with regard to the manner in which the Accused Quanta Laptops include and utilize PCIe and/or USB 3.x functionality. This Section is thus illustrative of the manner in which Quanta infringes the claims of the ’436 patent as to each of the Accused Quanta Laptops.

275. ACQIS’ infringement allegations against the Accused Quanta Laptops are not limited to claim 13 of the ’436 patent, and additional infringed claims will be identified through infringement contentions and discovery.

276. Quanta’s infringement of the ’436 patent through its manufacture, use, offers to sell, and/or sales in, and/or importation into, the United States of the Accused Quanta Desktops is shown by way of the exemplary desktop, the iMac (21.5-inch, 2017) desktop as set forth in paragraphs 99-113 above, which demonstrates infringement of at least claim 13 of the ’436 patent by showing:

- (a) the exemplary desktop is a computer;
- (b) the exemplary desktop has a first LVDS channel comprising at least two sets of unidirectional, multiple serial bit channels to convey data in opposite directions, including but not limited to its PCIe and OPI channels;
- (c) the exemplary desktop has an integrated central processing unit (CPU) with a

peripheral controller in a single chip directly coupled to one or more LVDS channels which can communicate encoded address and data bits of Peripheral Component Interconnect (PCI) bus transaction in serial form, because the 7th Generation Intel® Core™ i5 (“Kaby Lake”) Processors employed in the exemplary desktop are directly coupled including but not limited to its PCIe and OPI channels;

- (d) the exemplary desktop has system memory directly coupled to the integrated CPU and interface controller;
- (e) the exemplary desktop has a mass storage device coupled to the CPU, because the 7th Generation Intel® Core™ i5 (“Kaby Lake”) Processors employed in the exemplary desktop are coupled to an SSD; and
- (f) the exemplary desktop has a second LVDS channel which convey digital video data that are directly coupled to the integrated CPU with graphics controller, because the 7th Generation Intel® Core™ i5 (“Kaby Lake”) Processors employed in the exemplary desktop are directly coupled to eDP and/or DDI channels.

277. On information and belief, the Accused Quanta Desktops are in relevant part substantially similar to the exemplary desktop, in particular with regard to the manner in which the Accused Quanta Desktops include and utilize PCIe and/or USB 3.x functionality. This Section is thus illustrative of the manner in which Quanta infringes the claims of the ’436 patent as to each of the Accused Quanta Desktops.

278. ACQIS’ infringement allegations against the Accused Quanta Desktops are not limited to claim 13 of the ’436 patent, and additional infringed claims will be identified through infringement contentions and discovery.

279. As early as around May 14, 2018, Quanta had actual notice of the '436 patent and the infringement alleged herein.

280. The above-described acts of infringement committed by Quanta have caused injury and damage to ACQIS and ACQIS' licensees.

281. ACQIS is entitled to recover all damages sustained as a result of Quanta's wrongful acts of infringement, but in no event less than a reasonable royalty pursuant to 35 U.S.C. § 284.

282. Quanta's infringement as described herein has been willful and exceptional. Accordingly, ACQIS is entitled to recover enhanced damages up to three times the amount found or assessed at trial pursuant to 35 U.S.C. § 284, as well as its attorneys' fees pursuant to 35 U.S.C. § 285.

JURY TRIAL DEMANDED

ACQIS LLC hereby demands a trial by jury on all claims and issues so triable.

PRAYER FOR RELIEF

WHEREFORE, Plaintiff ACQIS LLC respectfully requests that this Court grant the following relief to ACQIS LLC:

A. enter judgment that Quanta has infringed one or more claims of each of the ACQIS Patents through: (1) the manufacture, use, offering to sell, and/or sale in the United States, and/or the importation into the United States, of infringing Quanta computer products; (2) the practice of claimed methods of the ACQIS Patents by manufacturing, using, and/or testing Quanta computer products in the United States; and (3) the importation into the United States of Quanta computer products made abroad using patented processes claimed in the ACQIS Patents;

B. enter judgement that such infringement is willful;

C. enter judgment awarding ACQIS monetary relief pursuant to 35 U.S.C. § 284 in an amount adequate to compensate for Quanta's infringement of the ACQIS Patents to be determined at trial, but not less than a reasonable royalty, awarding ACQIS all pre- and post-judgment interest and costs, and awarding ACQIS enhanced damages for Quanta's willful infringement of the ACQIS Patents;

D. enter an order, pursuant to 35 U.S.C. § 285, declaring this an exceptional case and awarding to ACQIS its reasonable attorneys' fees; and

E. enter an order awarding to ACQIS such other and further relief, whether at law or in equity, that this Court seems just, equitable, and proper.

Dated: April 10, 2023.

Respectfully submitted,

By: /s/ Andrea L. Fair

Charles Everingham IV
Texas State Bar No. 00787447
E-mail: ce@wsfirm.com
Claire Abernathy Henry
Texas State Bar No. 00787447
E-mail: claire@wsfirm.com
Andrea L. Fair
Texas State Bar No. 24078488
E-mail: andrea@wsfirm.com
WARD, SMITH & HILL, PLLC
1507 Bill Owens Parkway
Longview, TX 75604
(903) 757-6400 (telephone)
(903) 757-2323 (facsimile)

Attorneys for Plaintiff ACQIS LLC