

**IN THE UNITED STATES DISTRICT COURT
FOR THE WESTERN DISTRICT OF TEXAS
WACO DIVISION**

REDWOOD TECHNOLOGIES, LLC,

Plaintiff,

v.

**QUALCOMM INCORPORATED AND
QUALCOMM TECHNOLOGIES, INC.,**

Defendants.

§
§
§
§ **JURY TRIAL DEMANDED**
§
§ **C.A. NO. 6:23-cv-697**
§
§
§

PLAINTIFF’S COMPLAINT FOR PATENT INFRINGEMENT

Plaintiff Redwood Technologies, LLC (“Redwood”) files this Complaint against Defendants Qualcomm Incorporated and Qualcomm Technologies, Inc. (“Qualcomm” or “Defendants”) for infringement of U.S. Patent No. 7,359,457 (the “’457 patent”), U.S. Patent No. 7,460,485 (the “’485 patent”), U.S. Patent No. 7,701,920 (the “’920 patent”), U.S. Patent No. 7,826,555 (the “’555 patent”), U.S. Patent No. 7,983,140 (the “’140 patent”), U.S. Patent No. 8,218,501 (the “’501 patent”), U.S. Patent No. 9,374,209 (the “’209 patent”), and U.S. Patent No. 10,270,574 (the “’574 patent”), collectively, the “Asserted Patents.”

THE PARTIES

1. Redwood Technologies, LLC is a Texas limited liability company, with a principal place of business at 812 West McDermott Dr. #1038, Allen, TX 75013.

2. On information and belief, Qualcomm Incorporated is a corporation organized and existing under the laws of Delaware, having places of business at 9600 N. MoPac, Suite 900, Stonebridge Plaza II, Austin, Texas 78759 and 13929 Center Lake Drive, Parmer Building 1, Austin, Texas 78753.

3. On information and belief, Qualcomm Technologies, Inc. (“QTI”) is a corporation organized and existing under the laws of Delaware, having places of business at 9600 N. MoPac, Suite 900, Stonebridge Plaza II, Austin, Texas 78759 and 13929 Center Lake Drive, Parmer Building 1, Austin, Texas 78753.

4. QTI is a wholly-owned subsidiary of Qualcomm Incorporated and operates, along with its other subsidiaries, substantially all of Qualcomm’s engineering, research and development functions, and substantially all of its products and services businesses. *See* <https://www.qualcomm.com/company>.

5. QTI includes its other subsidiaries, including at least Qualcomm CDMA Technologies and Qualcomm CDMA Technologies Asia Pacific Pte. Ltd.

6. Qualcomm Incorporated and QTI together comprise one of the world’s largest manufacturers of integrated circuits for the wireless industry. Qualcomm Inc. and QTI are part of the same corporate structure. Qualcomm’s website states that “[r]eferences to ‘Qualcomm’ may mean Qualcomm Incorporated, or subsidiaries or business units within the Qualcomm corporate structure, as applicable.” *Id.* Qualcomm’s website further states that “Qualcomm Technologies, Inc., a subsidiary of Qualcomm Incorporated, operates, along with its subsidiaries, substantially all of our engineering, research and development functions, and substantially all of our products and services businesses, including our QCT semiconductor business.” *Id.*

7. Qualcomm Incorporated, QTI, and their subsidiaries and related companies share the same management, common ownership, advertising platforms, facilities, distribution and sales channels, and accused product lines and products. Qualcomm Incorporated, QTI, and their subsidiaries and related companies operate as a unitary business venture and are jointly and severally liable for the acts of patent infringement alleged herein.

8. Qualcomm Incorporated, QTI, and their subsidiaries and related companies together are doing business, either directly or through their agents, on an ongoing basis in this district and elsewhere in the United States and have a regular and established place of business in this district.

9. Prior to the filing of the Complaint, Redwood sent a letter received by Qualcomm on November 5, 2021, where Redwood attempted to engage Qualcomm in licensing discussions related to the Asserted Patents for reasonable and non-discriminatory terms for a license to be taken in the absence of litigation. Indeed, Qualcomm has known about each of the Asserted Patents since at least November 5, 2021, when Qualcomm received notice of its infringement of the Asserted Patents via the letter sent by Redwood.

10. Prior to the filing of the Complaint, Redwood sent several emails to Qualcomm, including an email received by Qualcomm on May 12, 2022, where Redwood again attempted to engage Qualcomm in licensing discussions related to the Asserted Patents for reasonable and non-discriminatory terms for a license to be taken in the absence of litigation. Indeed, Qualcomm has known about each of the Asserted Patents since at least May 12, 2022, when Qualcomm received the second notice of its infringement of the Asserted Patents via the email sent by Redwood.

11. To date, Qualcomm has not agreed to license the Asserted Patents for reasonable and non-discriminatory terms. Redwood and Qualcomm conducted five calls between December 15, 2021 and April 12, 2023, during which technical and non-technical discussions took place. Redwood and Qualcomm conducted a sixth call on June 9, 2023, where Redwood provided Qualcomm with a lump sum offer pursuant to reasonable and non-discriminatory terms for a license to Redwood's patent portfolio. Qualcomm abruptly and unilaterally made the decision to end the call despite Redwood's readiness to continue with negotiations. On that same day,

Redwood emailed Qualcomm advising them that Redwood's offer would be valid for 60 days and notifying Qualcomm that Redwood considered any RAND obligations to the IEEE fulfilled because of Qualcomm's apparent termination of the negotiations. Subsequently, Qualcomm failed to provide any response to Redwood during this 60 day time period. Redwood sent an email on August 8, 2023 notifying Qualcomm that no communications had been received and that Redwood must interpret Qualcomm's silence as a disinterest in pursuing further discussions.

12. Furthermore, as a member of the relevant standards-setting bodies, on information and belief, Qualcomm is on notice of standard essential patents issued to other members of the standards bodies.

13. Qualcomm's past and continuing making, using, selling, offering for sale, and/or importing, and/or inducing subsidiaries, affiliates, retail partners, distributors, manufacturers of end user devices, customers, and other third parties in the making, using, selling, offering for sale, and/or importing the accused Wi-Fi compliant devices throughout the United States i) willfully infringe each of the Asserted Patents and ii) impermissibly take the significant benefits of Redwood's patented technologies without fair compensation to Redwood.

14. Qualcomm is engaged in making, using, selling, offering for sale, and/or importing, and/or induces subsidiaries, affiliates, retail partners, distributors, manufacturers of end user devices, sellers of end user devices, consumers of end user devices, customers, and other third parties in the making, using, selling, offering for sale, and/or importing throughout the United States, including within this District, Wi-Fi products, such as Wi-Fi components as well as access points and mobile devices that include Qualcomm's Wi-Fi components, accused of infringement.

JURISDICTION AND VENUE

15. This action arises under the patent laws of the United States, namely 35 U.S.C. §§ 271, 281, and 284-285, among others.

16. This Court has subject matter jurisdiction pursuant to 28 U.S.C. §§ 1331 and 1338(a).

17. This Court has personal jurisdiction over Qualcomm in accordance with due process and/or the Texas Long Arm Statute because, among other things, Qualcomm does business in this State by, among other things, maintaining offices in this District, including maintaining its offices located at 9600 N. MoPac, Suite 900, Stonebridge Plaza II, Austin, Texas 78759 and 13929 Center Lake Drive, Parmer Building 1, Austin, Texas 78753.

18. Further, this Court has personal jurisdiction over Qualcomm because it has engaged, and continues to engage, in continuous, systematic, and substantial activities within this State, including the substantial marketing, making, using, and sale of products and services within this State and this District. Indeed, this Court has personal jurisdiction over Qualcomm because it has committed acts giving rise to Redwood's claims for patent infringement within and directed to this District, has derived substantial revenue from its goods and services provided to individuals in this State and this District, and maintains regular and established places of business in this District, including its places of business at 9600 N. MoPac, Suite 900, Stonebridge Plaza II, Austin, Texas 78759 and 13929 Center Lake Drive, Parmer Building 1, Austin, Texas 78753.

19. Relative to patent infringement, Qualcomm has committed and continues to commit acts in violation of 35 U.S.C. § 271, and has made, used, marketed, distributed, offered for sale, imported, and/or sold infringing products in this State, including in this District, and otherwise engaged in infringing conduct within and directed at, or from, this District. Such

products have been and continue to be offered for sale, distributed to, sold, and used in this District, and the infringing conduct has caused, and continues to cause, injury to Redwood, including injury suffered within this District. These are purposeful acts and transactions in this State and this District such that Qualcomm reasonably should know and expect that it could be haled into this Court because of such activities.

20. In addition, Qualcomm has knowingly induced and continues to knowingly induce infringement within this District by advertising, marketing, offering for sale, and/or selling infringing devices within this District, to consumers, customers, manufacturers, distributors, resellers, partners, and/or end users, and providing instructions, user manuals, advertising, marketing materials, hardware, software, and/or firmware which facilitate, direct or encourage the use of infringing functionality with knowledge thereof.

21. Venue is proper in this District under 28 U.S.C. §§ 1391 and 1400(b) because Qualcomm has regular and established places of business in this District and has committed acts of infringement in this District. Qualcomm's regular and established places of business in this District include, at least, its facilities at 9600 N. MoPac, Suite 900, Stonebridge Plaza II, Austin, Texas 78759 and 13929 Center Lake Drive, Parmer Building 1, Austin, Texas 78753.

22. With respect to the '457 patent, '555 patent, '140 patent, '209 patent, and '574 patent, the Accused Products are devices that include, but are not limited to, Qualcomm's devices and third party devices that include one or more of Qualcomm's devices that are compliant with IEEE 802.11n and/or IEEE 802.11ac and/or IEEE 802.11ax and/or 802.11be (e.g., 9207 LTE Modem, APQ8009, APQ8016E, APQ8053Pro, APQ8053Lite, APQ8074, APQ8094, APQ8096SG, AR6004 Chipset, CSR6030, CSRS3703, CSRS3713, CSRS3718, DragonBoard 410c, Dragonboard 845c, FastConnect 6100 Mobile Connectivity System, FastConnect 6200,

FastConnect 6700, FastConnect 6800, FastConnect 6900, FastConnect 7800, Flight RB5 5G Platform, Home Hub 100 Dev Kit for Amazon AVS, Home Hub 100 Platform, Immersive Home 214 Platform, Immersive Home 216 Platform, Immersive Home 316 Platform, Immersive Home 318 Platform, Immersive Home 3210 Platform, Immersive Home 326 Platform, IPQ4018 SoC, IPQ4019 SoC, IPQ4028 SoC, IPQ4029 SoC, IPQ8064 SoC, IPQ8065 SoC, IPQ8066 SoC, IPQ8068 SoC, IPQ8069 SoC, IPQ8074, Mesh Networking Dev Kit for Amazon AVS, Networking Pro 1200 Platform, Networking Pro 1210 Platform, Networking Pro 1220 Platform, Networking Pro 1610 Platform, Networking Pro 1620 Platform, Networking Pro 400 Platform, Networking Pro 600 Platform, Networking Pro 610 Platform, Networking Pro 620 Platform, Networking Pro 800 Platform, Networking Pro 810 Platform, Networking Pro 820 Platform, QCA1062, QCA1064, QCA206x, QCA4002, QCA4004, QCA4010, QCA4012, QCA4020, QCA4020 Product Development Kit, QCA4531, QCA6174A, QCA6175A, QCA6335, QCA6436, QCA6564AU, QCA6574AU, QCA6595AU, QCA6678AQ, QCA6696, QCA6698AQ, QCA9377, QCA9379, QCA9500, QCA9531, QCA9565, QCA9880, QCA9886 SoC, QCA9887 SoC, QCA9888 SoC, QCA9889 SoC, QCA9980, QCA9982 SoC, QCA9984 SoC, QCA9990 SoC, QCA9992 SoC, QCA9994 SoC, QCM2150, QCM2290, QCM4290, QCM4490, QCM5430, QCM6125, QCM6490, QCM8550, QCS2290, QCS403, QCS404, QCS405, QCS407, QCS410, QCS4290, QCS4490, QCS5430, QCS603, QCS605, QCS610, QCS6125, QCS6490, QCS7230, QCS8250, QCS8550, QRB5165, Qualcomm 205 Mobile Platform, Qualcomm 212 Mobile Platform, Qualcomm 215 Mobile Platform, QXF207x, QXM108x, QXM19xx, QXM80xx, Robotics RB1 Platform, Robotics RB2 Platform, Robotics RB3 Platform, Robotics RB5 Platform, Robotics RB5 Development Kit, Robotics RB6 Platform, SDA660, SDA845, SDM660, SDM845, Smart Audio Platform Development Kit, Smart Audio 200 Platform, Smart Audio 400 Platform, Snapdragon

Auto 4G Modem, Smart Display 200 Platform, Snapdragon 1200 Wearable Platform, Snapdragon 200 Processor, Snapdragon 208 Processor, Snapdragon 210 Processor, Snapdragon 205 Mobile Platform, Snapdragon 212 Mobile Platform, Snapdragon 215 Mobile Platform, Snapdragon 4 Gen 1 Mobile Platform, Snapdragon 4 Gen 2 Mobile Platform, Snapdragon 400 Processor, Snapdragon 410 Processor, Snapdragon 412 Processor, Snapdragon 415 Processor, Snapdragon 425 Mobile Platform, Snapdragon 427 Mobile Platform, Snapdragon 429 Mobile Platform, Snapdragon 430 Mobile Platform, Snapdragon 435 Mobile Platform, Snapdragon 439 Mobile Platform, Snapdragon 450 Mobile Platform, Snapdragon 460 Mobile Platform, Snapdragon 480 5G Mobile Platform, Snapdragon 480+ 5G Mobile Platform, Snapdragon 6 Gen 1 Mobile Platform, Snapdragon 600 Processor, Snapdragon 602 Automotive Platform, Snapdragon 610 Processor, Snapdragon 615 Processor, Snapdragon 616 Processor, Snapdragon 617 Processor, Snapdragon 625 Mobile Platform, Snapdragon 626 Mobile Platform, Snapdragon 630 Mobile Platform, Snapdragon 632 Mobile Platform, Snapdragon 636 Mobile Platform, Snapdragon 650 Mobile Platform, Snapdragon 652 Mobile Platform, Snapdragon 653 Mobile Platform, Snapdragon 660 Mobile Platform, Snapdragon 662 Mobile Platform, Snapdragon 665 Mobile Platform, Snapdragon 670 Mobile Platform, Snapdragon 675 Mobile Platform, Snapdragon 678 Mobile Platform, Snapdragon 680 4G Mobile Platform, Snapdragon 685 4G Mobile Platform, Snapdragon 690 5G Mobile Platform, Snapdragon 695 5G Mobile Platform, Snapdragon 7 Gen 1 Mobile Platform, Snapdragon 7+ Gen 2 Mobile Platform, Snapdragon 710 Mobile Platform, Snapdragon 712 Mobile Platform, Snapdragon 720G Mobile Platform, Snapdragon 730 Mobile Platform, Snapdragon 730G Mobile Platform, Snapdragon 732G Mobile Platform, Snapdragon 750G 5G Mobile Platform, Snapdragon 765 5G Mobile Platform, Snapdragon 765G 5G Mobile Platform, Snapdragon 768G 5G Mobile Platform, Snapdragon 778G 5G Mobile Platform, Snapdragon

778G+ 5G Mobile Platform, Snapdragon 780G 5G Mobile Platform, Snapdragon 782G Mobile Platform, Snapdragon 7c Compute Platform, Snapdragon 7c Gen 2 Compute Platform, Snapdragon 7c+ Gen 3 Compute Platform, Snapdragon 8 Gen 1 Mobile Platform, Snapdragon 8 Gen 2 Mobile Platform, Snapdragon 8+ Gen 1 Mobile Platform, Snapdragon 800 Processor, Snapdragon 801 Processor, Snapdragon 805 Processor, Snapdragon 808 Processor, Snapdragon 810 Processor, Snapdragon 820 Mobile Platform, Snapdragon 821 Mobile Platform, Snapdragon 835 Mobile PC Platform, Snapdragon 835 Mobile Platform, Snapdragon 845 Mobile Platform, Snapdragon 850 Mobile Compute Platform, Snapdragon 855 Mobile Platform, Snapdragon 855+/860 Mobile Platform, Snapdragon 865 5G Mobile Platform, Snapdragon 865+ 5G Mobile Platform, Snapdragon 870 5G Mobile Platform, Snapdragon 888 5G Mobile Platform, Snapdragon 888+ 5G Mobile Platform, Snapdragon 8c Compute Platform, Snapdragon 8cx Compute Platform, Snapdragon 8cx Gen 2 5G Compute Platform, Snapdragon 8cx Gen 3 Compute Platform, Snapdragon AR2 Gen 1 Platform, Snapdragon System-in-Package, Snapdragon W5+ Gen 1 Wearable Platform, Snapdragon Wear 1100 Platform, Snapdragon Wear 2100 Platform, Snapdragon Wear 2500 Platform, Snapdragon Wear 3100 Platform, Snapdragon Wear 4100+ Platform, Snapdragon XR1 Platform, Snapdragon XR2 5G Platform, Snapdragon XR2+ Gen 1 Platform, Video Collaboration VC1 Platform, Video Collaboration VC3 Platform, Video Collaboration VC3 Platform, Video Collaboration VC5 Platform, Vision Intelligence 100 Platform, Vision Intelligence 200 Platform, Vision Intelligence 300 Platform, Vision Intelligence 400 Platform), as well as, their components (*e.g.*, hardware, software, and/or firmware), and processes related to the same. With respect to the '485 patent, the Accused Products are devices that include, but are not limited to, Qualcomm's devices and third party devices that include one or more of Qualcomm's devices that are compliant with Wi-Fi Multimedia ("WMM") (*e.g.*, 9207

LTE Modem, APQ8009, APQ8016E, APQ8053Pro, APQ8053Lite, APQ8074, APQ8094, APQ8096SG, AR6004 Chipset, CSR6030, CSRS3703, CSRS3713, CSRS3718, DragonBoard 410c, Dragonboard 845c, FastConnect 6100 Mobile Connectivity System, FastConnect 6200, FastConnect 6700, FastConnect 6800, FastConnect 6900, FastConnect 7800, Flight RB5 5G Platform, Home Hub 100 Dev Kit for Amazon AVS, Home Hub 100 Platform, Immersive Home 214 Platform, Immersive Home 216 Platform, Immersive Home 316 Platform, Immersive Home 318 Platform, Immersive Home 3210 Platform, Immersive Home 326 Platform, IPQ4018 SoC, IPQ4019 SoC, IPQ4028 SoC, IPQ4029 SoC, IPQ8064 SoC, IPQ8065 SoC, IPQ8066 SoC, IPQ8068 SoC, IPQ8069 SoC, IPQ8074, Mesh Networking Dev Kit for Amazon AVS, Networking Pro 1200 Platform, Networking Pro 1210 Platform, Networking Pro 1220 Platform, Networking Pro 1610 Platform, Networking Pro 1620 Platform, Networking Pro 400 Platform, Networking Pro 600 Platform, Networking Pro 610 Platform, Networking Pro 620 Platform, Networking Pro 800 Platform, Networking Pro 810 Platform, Networking Pro 820 Platform, QCA1062, QCA1064, QCA206x, QCA4002, QCA4004, QCA4010, QCA4012, QCA4020, QCA4020 Product Development Kit, QCA4531, QCA6174A, QCA6175A, QCA6335, QCA6436, QCA6564AU, QCA6574AU, QCA6595AU, QCA6678AQ, QCA6696, QCA6698AQ, QCA9377, QCA9379, QCA9500, QCA9531, QCA9565, QCA9880, QCA9886 SoC, QCA9887 SoC, QCA9888 SoC, QCA9889 SoC, QCA9980, QCA9982 SoC, QCA9984 SoC, QCA9990 SoC, QCA9992 SoC, QCA9994 SoC, QCM2150, QCM2290, QCM4290, QCM4490, QCM5430, QCM6125, QCM6490, QCM8550, QCS2290, QCS403, QCS404, QCS405, QCS407, QCS410, QCS4290, QCS4490, QCS5430, QCS603, QCS605, QCS610, QCS6125, QCS6490, QCS7230, QCS8250, QCS8550, QRB5165, Qualcomm 205 Mobile Platform, Qualcomm 212 Mobile Platform, Qualcomm 215 Mobile Platform, QXF207x, QXM108x, QXM19xx, QXM80xx, Robotics RB1

Platform, Robotics RB2 Platform, Robotics RB3 Platform, Robotics RB5 Platform, Robotics RB5 Development Kit, Robotics RB6 Platform, SDA660, SDA845, SDM660, SDM845, Smart Audio Platform Development Kit, Smart Audio 200 Platform, Smart Audio 400 Platform, Snapdragon Auto 4G Modem, Smart Display 200 Platform, Snapdragon 1200 Wearable Platform, Snapdragon 200 Processor, Snapdragon 208 Processor, Snapdragon 210 Processor, Snapdragon 205 Mobile Platform, Snapdragon 212 Mobile Platform, Snapdragon 215 Mobile Platform, Snapdragon 4 Gen 1 Mobile Platform, Snapdragon 4 Gen 2 Mobile Platform, Snapdragon 400 Processor, Snapdragon 410 Processor, Snapdragon 412 Processor, Snapdragon 415 Processor, Snapdragon 425 Mobile Platform, Snapdragon 427 Mobile Platform, Snapdragon 429 Mobile Platform, Snapdragon 430 Mobile Platform, Snapdragon 435 Mobile Platform, Snapdragon 439 Mobile Platform, Snapdragon 450 Mobile Platform, Snapdragon 460 Mobile Platform, Snapdragon 480 5G Mobile Platform, Snapdragon 480+ 5G Mobile Platform, Snapdragon 6 Gen 1 Mobile Platform, Snapdragon 600 Processor, Snapdragon 602 Automotive Platform, Snapdragon 610 Processor, Snapdragon 615 Processor, Snapdragon 616 Processor, Snapdragon 617 Processor, Snapdragon 625 Mobile Platform, Snapdragon 626 Mobile Platform, Snapdragon 630 Mobile Platform, Snapdragon 632 Mobile Platform, Snapdragon 636 Mobile Platform, Snapdragon 650 Mobile Platform, Snapdragon 652 Mobile Platform, Snapdragon 653 Mobile Platform, Snapdragon 660 Mobile Platform, Snapdragon 662 Mobile Platform, Snapdragon 665 Mobile Platform, Snapdragon 670 Mobile Platform, Snapdragon 675 Mobile Platform, Snapdragon 678 Mobile Platform, Snapdragon 680 4G Mobile Platform, Snapdragon 685 4G Mobile Platform, Snapdragon 690 5G Mobile Platform, Snapdragon 695 5G Mobile Platform, Snapdragon 7 Gen 1 Mobile Platform, Snapdragon 7+ Gen 2 Mobile Platform, Snapdragon 710 Mobile Platform, Snapdragon 712 Mobile Platform, Snapdragon 720G Mobile Platform, Snapdragon 730 Mobile Platform,

Snapdragon 730G Mobile Platform, Snapdragon 732G Mobile Platform, Snapdragon 750G 5G Mobile Platform, Snapdragon 765 5G Mobile Platform, Snapdragon 765G 5G Mobile Platform, Snapdragon 768G 5G Mobile Platform, Snapdragon 778G 5G Mobile Platform, Snapdragon 778G+ 5G Mobile Platform, Snapdragon 780G 5G Mobile Platform, Snapdragon 782G Mobile Platform, Snapdragon 7c Compute Platform, Snapdragon 7c Gen 2 Compute Platform, Snapdragon 7c+ Gen 3 Compute Platform, Snapdragon 8 Gen 1 Mobile Platform, Snapdragon 8 Gen 2 Mobile Platform, Snapdragon 8+ Gen 1 Mobile Platform, Snapdragon 800 Processor, Snapdragon 801 Processor, Snapdragon 805 Processor, Snapdragon 808 Processor, Snapdragon 810 Processor, Snapdragon 820 Mobile Platform, Snapdragon 821 Mobile Platform, Snapdragon 835 Mobile PC Platform, Snapdragon 835 Mobile Platform, Snapdragon 845 Mobile Platform, Snapdragon 850 Mobile Compute Platform, Snapdragon 855 Mobile Platform, Snapdragon 855+/860 Mobile Platform, Snapdragon 865 5G Mobile Platform, Snapdragon 865+ 5G Mobile Platform, Snapdragon 870 5G Mobile Platform, Snapdragon 888 5G Mobile Platform, Snapdragon 888+ 5G Mobile Platform, Snapdragon 8c Compute Platform, Snapdragon 8cx Compute Platform, Snapdragon 8cx Gen 2 5G Compute Platform, Snapdragon 8cx Gen 3 Compute Platform, Snapdragon AR2 Gen 1 Platform, Snapdragon System-in-Package, Snapdragon W5+ Gen 1 Wearable Platform, Snapdragon Wear 1100 Platform, Snapdragon Wear 2100 Platform, Snapdragon Wear 2500 Platform, Snapdragon Wear 3100 Platform, Snapdragon Wear 4100+ Platform, Snapdragon XR1 Platform, Snapdragon XR2 5G Platform, Snapdragon XR2+ Gen 1 Platform, Video Collaboration VC1 Platform, Video Collaboration VC3 Platform, Video Collaboration VC3 Platform, Video Collaboration VC5 Platform, Vision Intelligence 100 Platform, Vision Intelligence 200 Platform, Vision Intelligence 300 Platform, Vision Intelligence 400 Platform), as well as, their components (*e.g.*, hardware, software, and/or firmware), and

processes related to the same. With respect to the '920 patent, the Accused Products are devices that include, but are not limited to, Qualcomm's devices and third party devices that include one or more of Qualcomm's devices that are compliant with IEEE 802.11ay (*e.g.*, QCA642x, QCA6426, QCA6428, QCA643x, QCA6428, QCA64x8, and/or QCA64x1), as well as, their components (*e.g.*, hardware, software, and/or firmware), and processes related to the same. With respect to the '501 patent, the Accused Products are devices that include, but are not limited to, Qualcomm's devices and third party devices that include one or more of Qualcomm's devices that are compliant with IEEE 802.11k and/or IEEE 802.11r (*e.g.*, FastConnect 6900, QCA9880, QCM6490, QCS6490, Snapdragon 710 Mobile Platform, Snapdragon 712 Mobile Platform, Snapdragon 845 Mobile Platform), as well as, their components (*e.g.*, hardware, software, and/or firmware), and processes related to the same.¹

COUNT I

(INFRINGEMENT OF U.S. PATENT NO. 7,359,457)

23. Plaintiff incorporates paragraphs 1 through 22 herein by reference.

24. Redwood is the assignee of the '457 patent, entitled "Transmission Apparatus, Reception Apparatus and Digital Radio Communication Method," with ownership of all substantial rights in the '457 patent, including the right to exclude others and to enforce, sue, and recover damages for past and future infringements.

25. The '457 patent is valid, enforceable, and was duly issued in full compliance with Title 35 of the United States Code. The '457 patent issued from U.S. Patent Application No. 10/827,445.

¹ Each of the relevant standards cited herein, and related to the Asserted Patents, are specifically incorporated into this Complaint.

26. Qualcomm has and continues to directly and/or indirectly infringe one or more claims of the '457 patent in this judicial district and elsewhere in Texas and the United States.

27. Qualcomm directly infringes the '457 patent via 35 U.S.C. § 271(a) by making, using, offering for sale, selling, and/or importing the Accused Products, their components and processes, and/or products containing the same that incorporate the fundamental technologies covered by the '457 patent.

28. Furthermore, Defendants directly infringe the '457 patent through its direct involvement in the activities of its subsidiaries. Such subsidiaries conduct activities that constitute direct infringement of the '457 patent under 35 U.S.C. § 271(a) by making, using, offering for sale, selling, and/or importing those Accused Products, their components and processes, and/or products containing the same that incorporated the fundamental technologies covered by the '457 patent. Further, Defendants are vicariously liable for this infringing conduct of its subsidiaries (under both the alter ego and agency theories) because, as an example and on information and belief, Qualcomm Incorporated, QTI, and their subsidiaries and related companies are essentially the same company, and Qualcomm Incorporated and/or QTI have the right and ability to control their subsidiaries infringing acts and receive a direct financial benefit from the infringement of its subsidiaries. Furthermore, on information and belief, Qualcomm sells and makes the Accused Products outside of the United States, delivers those products to manufacturers, customers, distributors, and/or subsidiaries in the United States, or in the case that it delivers the Accused Products outside of the United States it does so intending and/or knowing that those products or products that are manufactured to include Qualcomm's Accused Products are destined for the United States and/or designing those products for inclusion in other products to be placed on sale and used in the United States, thereby directly infringing the '457 patent. *See, e.g., Lake Cherokee*

Hard Drive Techs., L.L.C. v. Marvell Semiconductor, Inc., 964 F. Supp. 2d 653, 658 (E.D. Tex. 2013).

29. For example, Qualcomm infringes claim 1 of the '457 patent via the Accused Products, including the FastConnect 7800. The Accused Products, including the FastConnect 7800, each are compliant with IEEE 802.11n and/or IEEE 802.11ac and/or IEEE 802.11ax and/or IEEE 802.11be, and each comprise a transmission apparatus of claim 1. *See, e.g.*, <https://www.qualcomm.com/products/technology/wi-fi/fastconnect/fastconnect-7800> (“The Qualcomm FastConnect 7800 is an advanced 14nm Wi-Fi and Bluetooth® Connectivity system delivering ultra-high speeds;” “Standards: 802.11be, 802.11ax, 802.11ac, 802.11n, 802.11g, 802.11b, 802.11a;” “Antenna Configuration: 2x2;” and “Spatial Streams: Up to 4.”).

30. The Accused Products, including the FastConnect 7800, each comprise circuitry and/or components (hardware and/or software) that determine a modulation system from among a plurality of modulation systems based on a communication situation. For example, the Accused Products utilize a Modulation and Coding Scheme (MCS) value that is used to determine the modulation, coding, and number of spatial channels based on information associated with a channel quality assessment. *See, e.g.*, Sections 19.3.5 and 19.3.13.4 of Part 11: Wireless LAN Medium Access Control (MAC) and Physical (PHY) Specifications of IEEE Std 802.11™ -2016 (“IEEE 802.11 2016”). Based on the results of the channel quality assessment, the Accused Products select an appropriate MCS value from a plurality of MCS values. *See, e.g.*, Section 19.3.5 and Table 19-27 of IEEE 802.11 2016.

31. The Accused Products, including the FastConnect 7800, each comprise circuitry and/or components (hardware and/or software) that modulate a digital transmission signal according to the modulation system previously determined and generates a first symbol. The first

symbol comprises a first quadrature baseband signal. For example, the Accused Products, including the FastConnect 7800, generate a first data symbol (e.g., Data), comprising a first quadrature baseband signal (e.g., an OFDM signal before up-conversion to the carrier frequency), that is modulated according to the MCS value. See, e.g., Section 19.3.5 and Figures 19-1 and 19-22 of IEEE 802.11 2016. The signal is a quadrature signal, in that it is expressed as a combination of sine and cosine waveforms. For example, when the 16-QAM modulation scheme is used, the following equation and constellation diagram are used to express the signal as a quadrature signal:

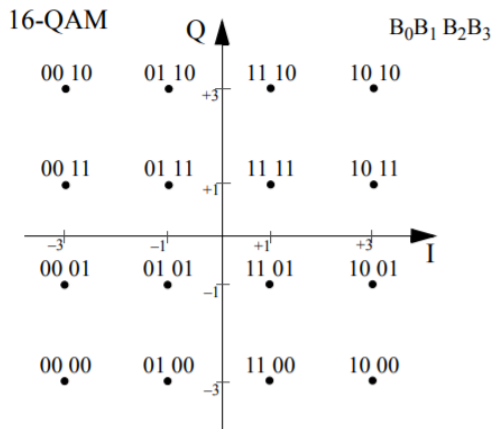

The signal is a quadrature signal because it is expressed with in-phase (I) and quadrature (Q) components. The signal is a baseband signal in that it has not been up-converted to the frequency of its intended carrier wave:

The transmitted signal is described in complex baseband signal notation. The actual transmitted signal is related to the complex baseband signal by the relation shown in Equation (19-1).

$$r_{RF}(t) = \text{Re}\{r(t)\exp(j2\pi f_c t)\} \quad (19-1)$$

where

f_c is the center frequency of the carrier

The transmitted RF signal is derived by modulating the complex baseband signal, which consists of several fields. The timing boundaries for the various fields are shown in Figure 19-4.

The mandatory PHY transmit procedure feature of annotated Figure 19-22 of IEEE 802.11 2016 is illustrated below:

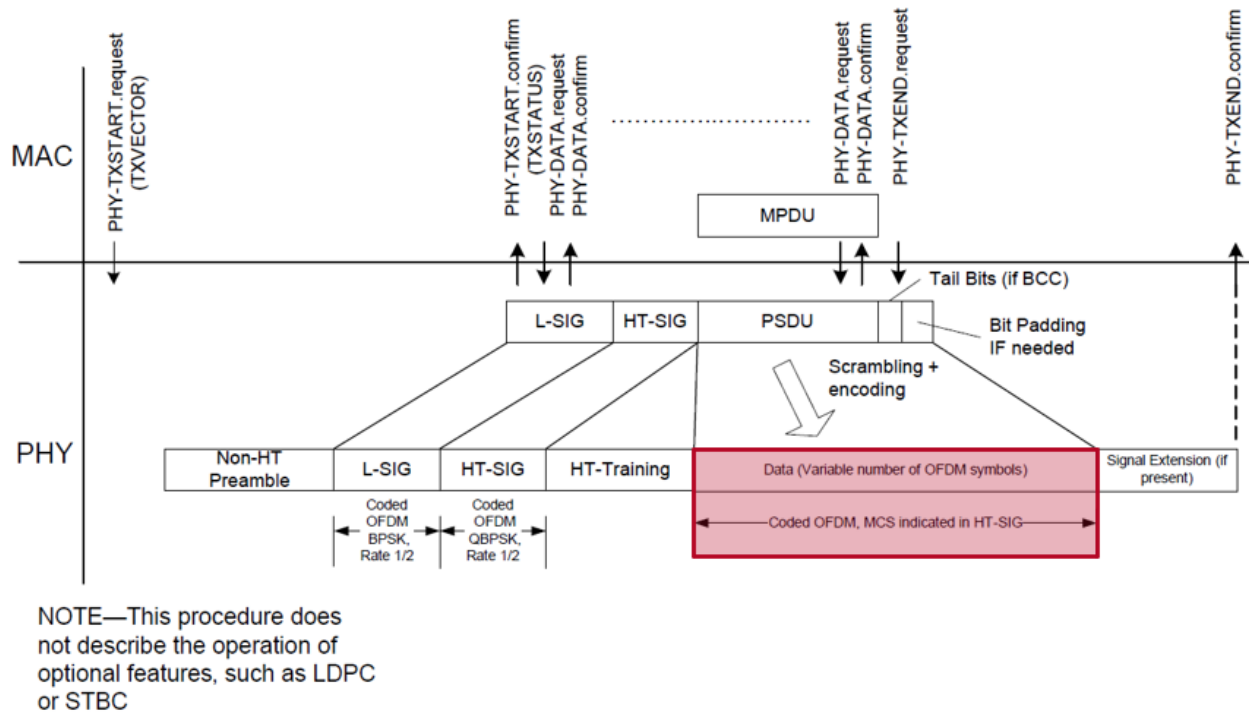

Figure 19-22—PHY transmit procedure (HT-mixed format PPDU)

Furthermore, an annotated passage of Section 19.3.20 directed to the mandatory “PHY transmit procedure” for HT-mixed format PPDU is recited below:

19.3.20 PHY transmit procedure

There are three options for the transmit PHY procedure. The first two options, for which typical transmit procedures are shown in Figure 19-22 and Figure 19-23, are selected if the FORMAT field of the PHY-TXSTART.request(TXVECTOR) primitive is equal to HT_MF or HT_GF, respectively. These transmit procedures do not describe the operation of optional features, such as LDPC or STBC. The third option is to follow the transmit procedure in Clause 17 or Clause 18 if the FORMAT field is equal to NON_HT. Additionally, if the FORMAT field is equal to NON_HT, CH_BANDWIDTH indicates

32.

33. The option for the “transmit PHY procedure” as to the HT-mixed format PPDU is a mandatory feature of the standard. See, e.g., https://www.albany.edu/faculty/dsaha/teach/2019Spring_CEN574/slides/08_WLAN.pdf at slides

67-68 (the HT-mixed format PPDU is mandatory). Thus, the Accused Devices, including the FastConnect 7800, must be configured pursuant to Figures 19-1 and 19-22, as described above.

34. The Accused Products, including the FastConnect 7800, each comprise circuitry and/or components (hardware and/or software) that modulates the digital signal according to a predetermined modulation system and generates a second symbol. The second symbol comprises a second quadrature baseband signal. For example, the Accused Products, including the FastConnect 7800, generate a second data symbol (e.g., the HT-SIG), comprising a second quadrature baseband signal (e.g., OFDM signal before up-conversion to the carrier frequency), that is modulated according to a predetermined modulation system (e.g., QBPSK). See, e.g., Section 19.3.9.4.3 and Figures 19-1 and 19-22 of IEEE 802.11 2016. The signal is a quadrature signal, in that it is expressed as a combination of sine and cosine waveforms. For example, when the QBPSK modulation scheme is used, the following constellation diagram is used to express the signal as a quadrature signal:

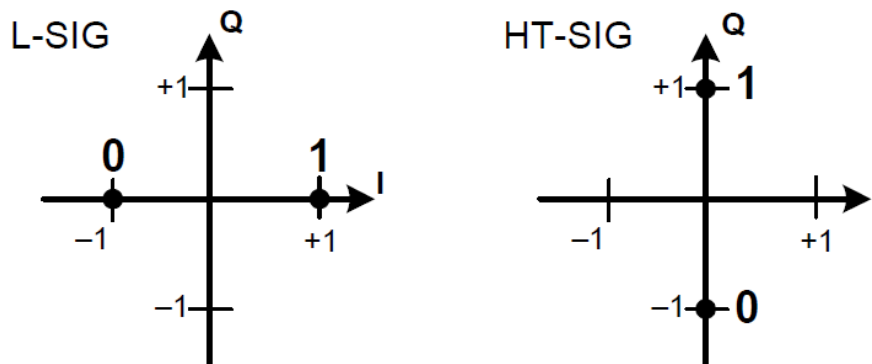

Figure 19-7—Data tone constellations in an HT-mixed format PPDU

The signal is a quadrature signal because it is expressed with in-phase (I) and quadrature (Q) components. The signal is a baseband signal in that it has not been up-converted to the frequency of its intended carrier wave:

The transmitted signal is described in complex baseband signal notation. The actual transmitted signal is related to the complex baseband signal by the relation shown in Equation (19-1).

$$r_{RF}(t) = \text{Re}\{r(t)\exp(j2\pi f_c t)\} \quad (19-1)$$

where

f_c is the center frequency of the carrier

The transmitted RF signal is derived by modulating the complex baseband signal, which consists of several fields. The timing boundaries for the various fields are shown in Figure 19-4.

35. The specific ways in which the Accused Products, including the FastConnect 7800, are configured to support the aforementioned features of IEEE 802.11n and/or IEEE 802.11ac and/or IEEE 802.11ax and/or IEEE 802.11be are further detailed in confidential documents and/or source code that evidence infringement by the Accused Products, including the FastConnect 7800, as to at least Claim 1 of the '457 patent.

36. Furthermore, the Accused Products, including the FastConnect 7800, are configured or implemented in an infringing manner with the features and functionality recited in at least Claim 1 of the '457 patent.

37. The technology discussion above and the exemplary Accused Products provide context for Plaintiff's infringement allegations.

38. The claims of the '457 patent are patent eligible under 35 U.S.C. § 101. The '457 patent is not directed to an ineligible abstract idea. For example, it is not a mathematical algorithm executed on a generic computer or a fundamental economic business practice. Instead, for example, it offers a technologically complex, particularized "transmission apparatus, reception apparatus and digital radio communication method capable of flexibly improving the data transmission efficiency and the quality of data." '457 patent, 1:59-63. The '457 patent provides a technical solution above, for example, by using a "[f]rame configuration determination section"

that “judges the communication situation based on transmission path information” to determine a modulation system from a plurality of modulation systems, then generate symbols comprising quadrature baseband signals, including one symbol that is generated by modulating a digital transmission signal according to the selected modulation system and a second symbol that is generated by modulating the digital transmission signal according to a predetermined modulation system. ’457 patent, 3:36-48; claim 1. That solution is reflected in the claims of the ’457 patent such as independent claims 1 and 6.

39. At a minimum, Qualcomm has known of the ’457 patent at least as early as the filing date of the Complaint. In addition, Qualcomm has known about the ’457 patent since at least November 5, 2021, when Qualcomm and/or its agents received notice of its infringement of the ’457 patent via a letter. On December 7, 2021, Qualcomm received further notice of its infringement of the ’457 patent when Qualcomm downloaded an infringement chart of the ’457 patent via a data room provided by Redwood. Furthermore, Qualcomm has known about the ’457 patent since at least May 12, 2022, when Qualcomm and/or its agents received further notice of its infringement via email. On information and belief, Qualcomm has had knowledge of the ’457 patent based at least on its conduct before the United States Patent and Trademark Office (“USPTO”). For example, at least one patent document related to the ’457 patent was cited by the Examiner during the prosecution of U.S. Patent No. 10,084,581 entitled “Overlay Unicast Or MBSFN Data Transmission On Top Of MBSFN Transmission” and assigned to Qualcomm.

40. On information and belief, since at least the above-mentioned dates when Qualcomm was on notice of its infringement, Qualcomm has actively induced, under U.S.C. § 271(b), distributors, customers, subsidiaries, importers, partners, affiliates, resellers, manufacturers, end users, and/or consumers that make, import, use, purchase, offer to sell, and/or

sell the Accused Products comprising all of the limitations of one or more claims of the '457 patent to directly infringe one or more claims of the '457 patent by making, using, offering for sale, selling, and/or importing the Accused Products. Since at least the notice provided on the above-mentioned dates, Qualcomm does so with knowledge, or with willful blindness of the fact, that the induced acts constitute infringement of the '457 patent. Qualcomm intends to cause, and has taken affirmative steps to induce infringement by distributors, customers, subsidiaries, importers, partners, affiliates, resellers, manufacturers, end users, and/or consumers by at least, inter alia, creating advertisements that promote the infringing use of the Accused Products, creating and/or maintaining and/or knowledge of established distribution channels for the Accused Products into and within the United States, manufacturing the Accused Products in conformity with U.S. laws and regulations, manufacturing the Accused Products in conformity with the relevant IEEE 802.11 standards, distributing or making available instructions or manuals for the Accused Products to purchasers and prospective buyers, providing the accused functionalities via hardware, software, and/or firmware that are included in the Accused Products to manufacturers, purchasers, sellers, distributors, and/or end users, testing and certifying features related to infringing features in the Accused Products, and/or providing technical support, replacement parts, or services for these products to these purchasers and/or sellers in the United States.

41. On information and belief, since at least the above-mentioned dates when Qualcomm was on notice of its infringement, Qualcomm's contributory infringement pursuant to 35 U.S.C. § 271(c) includes offering to sell and/or license, selling and/or licensing, and/or providing within the United States, or importing into the United States, components of the patented invention of one or more claims of the '457 patent, constituting a material part of the invention. On information and belief, Qualcomm knows and has known the same to be especially made or

especially adapted for use in an infringement of the '457 patent, and such components are not a staple article or commodity of commerce suitable for substantial noninfringing use. For example, Qualcomm offers to sell, sells, and/or licenses or otherwise provides hardware and/or software/firmware components of the Accused Products within the United States; the components constitute a material part of the claimed inventions of the '457 patent that are especially made or especially adapted for use in end user products that infringe the '457 patent; and the components are not a staple article or commodity of commerce suitable for substantial noninfringing use.

42. On information and belief, since at least the above-mentioned dates when Qualcomm was on notice of its infringement, Qualcomm's infringement pursuant to 35 U.S.C. § 271(f)(1) includes supplying or causing to be supplied in or from the United States all or a substantial portion of the components of the patented invention of one or more claims of the '457 patent, where such components are uncombined in whole or in part, in such manner as to actively induce the combination of such components outside of the United States in a manner that would infringe the patent if such combination occurred within the United States. For example, Qualcomm supplies or causes to be supplied in or from the United States the hardware and/or software/firmware components of the Accused Products that comprise all or a substantial portion of the components of the patented inventions of the '457 patent, where Qualcomm actively induces the combination of such components outside of the United States in a manner that would infringe the patent if such combination occurred within the United States. In another example, Qualcomm supplies or causes to be supplied in or from the United States the hardware and/or software/firmware components of the Accused Products that comprise all or a substantial portion of the components of the patented inventions of the '457 patent, where Qualcomm actively induces the combination of the hardware and/or software/firmware components with other components of

an end user device outside of the United States in a manner that would infringe the patent if such combination occurred within the United States. Qualcomm intends to cause, and has taken affirmative steps to induce infringement by distributors, customers, subsidiaries, importers, partners, affiliates, resellers, manufacturers, and/or consumers by at least, inter alia, creating advertisements that promote the infringing use of the Accused Products, creating and/or maintaining and/or knowledge of established distribution channels for the Accused Products into and within the United States, manufacturing the components of the Accused Products in conformity with U.S. laws and regulations, manufacturing the components of the Accused Products in conformity with the relevant IEEE 802.11 standards, distributing or making available instructions or manuals or marketing materials regarding the combination of the hardware and software/firmware components, distributing or making available instructions or manuals or marketing materials regarding the combination of the hardware and/or software/firmware components with other components as part of making an end user device in part or in whole, testing and certifying features related to infringing features in the Accused Products, providing software and/or firmware for the Accused Products to manufacturers, purchasers, sellers, distributors, and/or end users, and/or providing technical support, replacement parts, or services for these products to these purchasers and/or sellers in the United States.

43. On information and belief, since at least the above-mentioned dates when Qualcomm was on notice of its infringement, Qualcomm's infringement pursuant to 35 U.S.C. § 271(f)(2) includes supplying or causing to be supplied in or from the United States components of the patented invention of one or more claims of the '457 patent that are especially made or especially adapted for use in the invention and not staple articles or commodities of commerce suitable for substantial noninfringing use, where such components are uncombined in whole or in

part, knowing that such components are so made or adapted and intending that such components will be combined outside of the United States in a manner that would infringe the patent if such combination occurred within the United States. For example, Qualcomm supplies or causes to be supplied in or from the United States the hardware and/or software/firmware components that comprise all or a substantial portion of the components of the '457 patent, where such components are uncombined in whole or in part, knowing that such components are especially made or especially adapted for use in the invention and not staple articles or commodities of commerce suitable for substantial noninfringing use and intending that such components will be combined outside of the United States in a manner that would infringe the patent if such combination occurred within the United States. In another example, Qualcomm supplies or causes to be supplied in or from the United States the hardware and/or software/firmware components that comprise all or a substantial portion of the components of the patented inventions of the '457 patent, where such components are uncombined in whole or in part with other components of an end user device, knowing that such components are especially made or especially adapted for use in the invention and not staple articles or commodities of commerce suitable for substantial noninfringing use and intending that such components will be combined with other components of an end user device outside of the United States in a manner that would infringe the patent if such combination occurred within the United States.

44. On information and belief, despite having knowledge of the '457 patent and knowledge that it is directly and/or indirectly infringing one or more claims of the '457 patent, Qualcomm has nevertheless continued its infringing conduct and disregarded an objectively high likelihood of infringement. Qualcomm's infringing activities relative to the '457 patent have been, and continue to be, willful, wanton, malicious, in bad-faith, deliberate, consciously wrongful,

flagrant, characteristic of a pirate, and an egregious case of misconduct beyond typical infringement such that Plaintiff is entitled under 35 U.S.C. § 284 to enhanced damages up to three times the amount found or assessed.

45. Redwood has been damaged as a result of Qualcomm's infringing conduct described in this Count. Qualcomm is, thus, liable to Redwood in an amount that adequately compensates Redwood for Qualcomm's infringements, which, by law, cannot be less than a reasonable royalty, together with interest and costs as fixed by this Court under 35 U.S.C. § 284.

COUNT II

(INFRINGEMENT OF U.S. PATENT NO. 7,460,485)

46. Plaintiff incorporates paragraphs 1 through 45 herein by reference.

47. Redwood is the assignee of the '485 patent, entitled "Methods for Performing Medium Dedication in Order to Ensure the Quality of Service for Delivering Real-Time Data Across Wireless Network," with ownership of all substantial rights in the '485 patent, including the right to exclude others and to enforce, sue, and recover damages for past and future infringements.

48. The '485 patent is valid, enforceable, and was duly issued in full compliance with Title 35 of the United States Code. The '485 patent issued from U.S. Patent Application No. 10/654,901.

49. Qualcomm has and continues to directly and/or indirectly infringe (by inducing infringement) one or more claims of the '485 patent in this judicial district and elsewhere in Texas and the United States.

50. Qualcomm directly infringes the '485 patent via 35 U.S.C. § 271(a) by using and/or testing the Accused Products, their components and processes, and/or products containing the same that incorporate the fundamental technologies covered by the '485 patent.

51. Furthermore, Defendants directly infringe the '485 patent through its direct involvement in the activities of its subsidiaries. Such subsidiaries conduct activities that constitute direct infringement of the '485 patent under 35 U.S.C. § 271(a) by using and/or testing those Accused Products, their components and processes, and/or products containing the same that incorporated the fundamental technologies covered by the '485 patent. Further, Defendants are vicariously liable for this infringing conduct of its subsidiaries (under both the alter ego and agency theories) because, as an example and on information and belief, Qualcomm Incorporated, QTI, and their subsidiaries and related companies are essentially the same company, and Qualcomm Incorporated and/or QTI have the right and ability to control their subsidiaries infringing acts and receive a direct financial benefit from the infringement of its subsidiaries. Furthermore, on information and belief, Qualcomm sells and makes the Accused Products outside of the United States, delivers those products to manufacturers, customers, distributors, and/or subsidiaries in the United States, or in the case that it delivers the Accused Products outside of the United States it does so intending and/or knowing that those products or products that are manufactured to include Qualcomm's Accused Products are destined for the United States and/or designing those products for inclusion in other products to be placed on sale and used in the United States, thereby directly infringing the '485 patent. *See, e.g., Lake Cherokee Hard Drive Techs., L.L.C. v. Marvell Semiconductor, Inc.*, 964 F. Supp. 2d 653, 658 (E.D. Tex. 2013).

52. Qualcomm infringes claim 1 of the '485 patent via the Accused Products, including the FastConnect 7800. The Accused Products, including the FastConnect 7800, are compliant with the Wi-Fi Alliance WMM requirements. *See, e.g.,* https://www.wi-fi.org/product-finder-results?sort_by=certified&sort_order=desc&keywords=fastconnect%207800&companies=500 (evidencing that the FastConnect 7800 models are compliant with the Wi-Fi Alliance WMM

requirements). The Accused Products, including the FastConnect 7800, perform a method for guaranteeing a quality of service (QoS) in delivering real-time data across a transmission medium. *See, e.g.*, Section 4.3.10 of Part 11: Wireless LAN Medium Access Control (MAC) and Physical (PHY) Specifications of IEEE Std 802.11™ -2016 (“IEEE 802.11 2016”) and Section 1.0 of the Wi-Fi Alliance Wi-Fi Multimedia Technical Specification, Version 1.2.0 (“WMM Specification V1.2.0”).

53. The Accused Products, including the FastConnect 7800, each specify a traffic requirement for a traffic stream in accordance with a generic first specification. For example, the Accused Products utilize the traffic specification (“TSPEC”) element, which is a traffic requirement for a traffic stream based on QoS parameters for a particular Wi-Fi station (“STA”). *See, e.g.*, Section 9.4.2.30 of IEEE 802.11 2016 and Figure 14 of the WMM Specification V1.2.0.

54. The Accused Products, including the FastConnect 7800, each transform the specified traffic requirement in accordance with a generic second specification based on the specified traffic requirement, an overhead requirement for the traffic stream and a condition of the transmission medium. For example, the Accused Products receive the TSPEC from an STA, and the Accused Products transform the TSPEC into medium time. *See, e.g.*, Section 3.5.2 of the WMM Specification V1.2.0. Medium Time is a traffic stream requirement utilized by the Accused Products which takes into consideration elements from the TSPEC, overhead requirements, and expected error performance on the medium. *See, e.g.*, Section K.4.1 of IEEE 802.11 2016 and A.3 of the WMM Specification V1.2.0.

55. The Accused Products, including the FastConnect 7800, each adjust the generic second specification based on feedback obtained from monitoring the condition of the transmission

medium. For example, the Accused Products adjust the medium time with the receipt of each new TSPEC. *See, e.g.*, Sections 3.5.1 and 3.5.3 of the WMM Specification V1.2.0.

56. The Accused Products, including the FastConnect 7800, each aggregate a plurality of specifications for a plurality of traffic streams into a single specification to reduce resources required to maintain and process the plurality of specifications and overhead incurred in medium dedication. For example, the Accused Products aggregate the mean data rate and burst size for a plurality of traffic streams to generate a single token bucket specification, which allows the Accused Products to manage the STA's admitted flows more effectively. *See, e.g.*, Section 3.5.1 of the WMM Specification V1.2.0.

57. The Accused Products, including the FastConnect 7800, each perform medium dedication in accordance with the medium dedication schedule to coordinate transmission of the plurality of traffic streams. For example, the Accused Products perform the medium dedication according to the schedule to coordinate transmission between a plurality of STAs with admitted traffic streams. *See, e.g.*, Section 3.5.2 of the WMM Specification V1.2.0.

58. The specific ways in which the Accused Products, including the FastConnect 7800, are configured to support the aforementioned features of WMM are further detailed in confidential documents and/or source code that evidence infringement by the Accused Products, including the FastConnect 7800, as to Claim 1 of the '485 patent.

59. Furthermore, the Accused Products, including the FastConnect 7800, are configured or implemented in an infringing manner with the features and functionality recited in at least Claim 1 of the '485 patent.

60. The technology discussion above and the exemplary Accused Products provide context for Plaintiff's infringement allegations.

61. The claims of the '485 Patent are patent eligible under 35 U.S.C. § 101. The '485 Patent is not directed to an ineligible abstract idea. For example, it is not a mathematical algorithm executed on a generic computer or a fundamental economic business practice. Instead, it offers, for example, a technologically complex invention that delivers “time sensitive data, such as real-time Audio-Visual data for interactive applications, communicative applications and gaming, across an erroneous transmission medium.” '485 patent, 1:10-13. The '485 explains that “in order to meet the Quality of Service, data traffic need to be coordinated and scheduling of bandwidth dedication need to be performed.” '485 patent, 1:13-15. The '485 patent explains that its invention solves the problems identified by providing “a systematic way to perform medium dedication, by transforming traffic requirements into a form of specification that can incorporate the medium condition, by aggregating the specification to reduce overhead incurred, by merging individual medium dedication schedules for each stream into a unified medium dedication schedule, by performing medium dedication, by performing adaptation in order to tune the specification to be more reliable, and by performing monitoring and reporting of medium condition.” '485 patent, 1:29-38. That solution is reflected for example in independent claim 1 of the '485 patent.

62. At a minimum, Qualcomm has known of the '485 patent at least as early as the filing date of the Complaint. In addition, Qualcomm has known about the '485 patent since at least November 5, 2021, when Qualcomm and/or its agents received notice of its infringement of the '485 patent via a letter. On December 7, 2021, Qualcomm received further notice of its infringement of the '485 patent when Qualcomm downloaded an infringement chart of the '485 patent via a data room provided by Redwood. Furthermore, Qualcomm has known about the '485 patent since at least May 12, 2022, when Qualcomm and/or its agents received further notice of its infringement via email. On information and belief, Qualcomm has also had knowledge of the '485

patent based at least on its conduct before the USPTO. For example, at least one patent document related to the '485 patent was cited by the Examiner or otherwise known by Qualcomm during the prosecution of the following patent documents assigned to Qualcomm: U.S. Patent No. 7,653,085 entitled "Method And Apparatus For Enhanced Delivery Of Content Over Data Network;" U.S. Patent No. 7,974,193 entitled "Methods And Systems For Resizing Multimedia Content Based On Quality And Rate Information;" U.S. Patent No. 8,385,193 entitled "Method And Apparatus For Admission Control Of Data In A Mesh Network;" U.S. Patent No. 8,582,905 entitled "Methods And Systems For Rate Control Within An Encoding Device;" U.S. Patent Application Publication No. 2007/0214379 entitled "Transmission Control For Wireless Communication Networks;" and U.S. Patent No. 9,807,803 entitled "Transmission Control For Wireless Communication Networks."

63. On information and belief, since at least the above-mentioned dates when Qualcomm was on notice of its infringement, Qualcomm has actively induced, under U.S.C. § 271(b), distributors, customers, subsidiaries, importers, partners, affiliates, resellers, manufacturers, end users, and/or consumers to directly infringe one or more claims of the '485 patent by testing and/or using the Accused Products. Since at least the notice provided on the above-mentioned dates, Qualcomm does so with knowledge, or with willful blindness of the fact, that the induced acts constitute infringement of the '485 patent. Qualcomm intends to cause, and has taken affirmative steps to induce infringement by distributors, customers, subsidiaries, importers, partners, affiliates, resellers, manufacturers, end users, and/or consumers by at least, inter alia, creating advertisements that promote the infringing use of the Accused Products, creating and/or maintaining and/or knowledge of established distribution channels for the Accused Products into and within the United States, manufacturing the Accused Products in conformity

with U.S. laws and regulations, manufacturing the Accused Products in conformity with the relevant IEEE 802.11 and WMM standards, distributing or making available instructions or manuals for the Accused Products to purchasers and prospective buyers, providing the accused functionalities via hardware, software, and/or firmware that are included in the Accused Products that are then used and/or tested by distributors, customers, subsidiaries, importers, partners, affiliates, resellers, manufacturers, end users, and/or consumers, testing and certifying features related to infringing features in the Accused Products, and/or providing technical support, replacement parts, or services for these products to these purchasers and/or sellers in the United States.

64. On information and belief, since at least the above-mentioned dates when Qualcomm was on notice of its infringement, Qualcomm's contributory infringement pursuant to 35 U.S.C. § 271(c) includes offering to sell and/or license, selling and/or licensing, and/or providing within the United States, or importing into the United States, components of the patented invention of one or more claims of the '485 patent, constituting a material part of the invention. On information and belief, Qualcomm knows and has known the same to be especially made or especially adapted for use in an infringement of the '485 patent, and such components are not a staple article or commodity of commerce suitable for substantial noninfringing use. For example, Qualcomm offers to sell, sells, and/or licenses or otherwise provides hardware and/or software/firmware components of the Accused Products within the United States; the components constitute a material part of the claimed inventions of the '485 patent that are especially made or especially adapted for use in end user products that infringe the '485 patent; and the components are not a staple article or commodity of commerce suitable for substantial noninfringing use.

65. On information and belief, despite having knowledge of the '485 patent and knowledge that it is directly and/or indirectly infringing one or more claims of the '485 patent, Qualcomm has nevertheless continued its infringing conduct and disregarded an objectively high likelihood of infringement. Qualcomm's infringing activities relative to the '485 patent have been, and continue to be, willful, wanton, malicious, in bad-faith, deliberate, consciously wrongful, flagrant, characteristic of a pirate, and an egregious case of misconduct beyond typical infringement such that Plaintiff is entitled under 35 U.S.C. § 284 to enhanced damages up to three times the amount found or assessed.

66. Redwood has been damaged as a result of Qualcomm's infringing conduct described in this Count. Qualcomm is, thus, liable to Redwood in an amount that adequately compensates Redwood for Qualcomm's infringements, which, by law, cannot be less than a reasonable royalty, together with interest and costs as fixed by this Court under 35 U.S.C. § 284.

COUNT III

(INFRINGEMENT OF U.S. PATENT NO. 7,701,920)

67. Plaintiff incorporates paragraphs 1 through 66 herein by reference.

68. Redwood is the assignee of the '920 patent, entitled "Communication System, a Communication Method, and a Communication Apparatus for Carrying Out Data Communication Among a Plurality of Communication Stations," with ownership of all substantial rights in the '920 patent, including the right to exclude others and to enforce, sue, and recover damages for past and future infringements.

69. The '920 patent is valid, enforceable, and was duly issued in full compliance with Title 35 of the United States Code. The '920 patent issued from U.S. Patent Application No. 10/821,884.

70. Qualcomm has and continues to directly and/or indirectly infringe one or more claims of the '920 patent in this judicial district and elsewhere in Texas and the United States.

71. Qualcomm directly infringes the '920 patent via 35 U.S.C. § 271(a) by making, using, offering for sale, selling, and/or importing the Accused Products, their components and processes, and/or products containing the same that incorporate the fundamental technologies covered by the '920 patent.

72. Furthermore, Defendants directly infringe the '920 patent through its direct involvement in the activities of its subsidiaries. Such subsidiaries conduct activities that constitute direct infringement of the '920 patent under 35 U.S.C. § 271(a) by making, using, offering for sale, selling, and/or importing those Accused Products, their components and processes, and/or products containing the same that incorporated the fundamental technologies covered by the '920 patent. Further, Defendants are vicariously liable for this infringing conduct of its subsidiaries (under both the alter ego and agency theories) because, as an example and on information and belief, Qualcomm Incorporated, QTI, and their subsidiaries and related companies are essentially the same company, and Qualcomm Incorporated and/or QTI have the right and ability to control their subsidiaries infringing acts and receive a direct financial benefit from the infringement of its subsidiaries. Furthermore, on information and belief, Qualcomm sells and makes the Accused Products outside of the United States, delivers those products to manufacturers, customers, distributors, and/or subsidiaries in the United States, or in the case that it delivers the Accused Products outside of the United States it does so intending and/or knowing that those products or products that are manufactured to include Qualcomm's Accused Products are destined for the United States and/or designing those products for inclusion in other products to be placed on sale and used in the United States, thereby directly infringing the '920 patent. *See, e.g., Lake Cherokee*

Hard Drive Techs., L.L.C. v. Marvell Semiconductor, Inc., 964 F. Supp. 2d 653, 658 (E.D. Tex. 2013).

73. For example, Qualcomm infringes claim 13 of the '920 patent via the Accused Products. The Accused Products, including the QCA642x, QCA6426, QCA6428, QCA643x, QCA6428, QCA64x8, and/or QCA64x1, each comprise a communication apparatus for transmitting data to other communication stations and each are compliant with IEEE 802.11ay. <https://www.qualcomm.com/products/internet-of-things/networking/wi-fi-networks/qca6428>; <https://spectrum.ieee.org/qualcomm-introduces-new-chipsets-for-60-ghz-wifi>. Furthermore, the 802.11ay standard is referred to as Enhanced Directional Multi-Gigabit ("DMG"). The Accused Products, including the QCA642x, QCA6426, QCA6428, QCA643x, QCA6428, QCA64x8, and/or QCA64x1, are DMG wireless stations.

74. The Accused Products, including the QCA642x, QCA6426, QCA6428, QCA643x, QCA6428, QCA64x8, and/or QCA64x1, comprise data processing means for generating a request to send signal indicating a request to initiate data transmission, the request to send signal including an address of a second communication station that is intended to receive the data transmission. IEEE 802.11-2020 specifies distributed coordination functions (DCF) for DMG wireless stations. *See, e.g.*, Section 10.3.1 of IEEE 802.11-2020. For example, the Accused Products, including the QCA642x, QCA6426, QCA6428, QCA643x, QCA6428, QCA64x8, and/or QCA64x1, are configured to transmit a request to send (RTS) frame to a second wireless station, such that the RTS frame indicates the impending use of the medium to transmit a Data frame to the second wireless station, and the RTS frame includes a receiver address (RA), which is the address of the second wireless station. *See, e.g.*, Sections 9.3.1.2, 10.3.1, and Figure 9-30 of IEEE 802.11-2020.

75. The Accused Products, including the QCA642x, QCA6426, QCA6428, QCA643x, QCA6428, QCA64x8, and/or QCA64x1, comprise communication means for transmitting the request to send signal, and receiving a clear to send signal from said second communication station, in reply to the request to send signal. For example, the Accused Products are configured to transmit the RTS frame and receive a DMG clear to send (“CTS”) frame from the second communication station in reply to the RTS frame. *See, e.g.*, Sections 10.3.1 and 10.3.2.9 of IEEE 802.11-2020.

76. The clear to send signal includes at least a first section and a second section, where the first section includes information used to indicate an interval of time during which a third communication station having an address that is not included in the second section must stop its communication operation, and the second section includes the address of said first communication station, where the second communication station transmits the clear to send signal. For example, the DMG CTS frame includes a section that includes duration information specifying the amount of time the network allocates to the first communication station for transmission, such that a third communication having an address that is not included in the aforementioned DMG CTS frame must stop its communication operation during this interval of time. *See, e.g.*, Sections 9.3.1.13 and 9.2.5.2 and Figure 9-52 of IEEE 802.11-2020. The DMG CTS frame includes another section that includes the address of the first communication station. *See, e.g.*, Section 9.3.1.13 and Figure 9-52 of IEEE 802.11-2020. The second communication station transmits the DMG CTS frame. *See, e.g.*, Sections 10.3.1 and 10.3.2.9 and Figure 9-52 of IEEE 802.11-2020.

77. The specific ways in which the Accused Products are configured to support the aforementioned features, whether optional or mandatory, of IEEE 802.11ay are further detailed in confidential documents and/or source code that evidence infringement by the Accused Products as to at least claim 13 of the '920 patent.

78. Furthermore, the Accused Products are configured or implemented in an infringing manner with the features and functionality recited in at least claim 13 of the '920 patent.

79. The technology discussion above and the exemplary Accused Products provide context for Plaintiff's infringement allegations.

80. The claims of the '920 patent are patent eligible under 35 U.S.C. § 101. The '920 patent is not directed to an ineligible abstract idea. For example, it is not a mathematical algorithm executed on a generic computer or a fundamental economic business practice. Instead, the '920 patent describes a specific problem to be solved in wireless signal communications involving media access control of traditional RTS/CTS (request to send/clear to send) signaling protocol in the context of directional transmissions using directional antennas (e.g., adaptive array antennas) when directional signals are multiplexed in space based on the spatial arrangement of the receiving wireless devices. '920 patent, 2:64-65, 2:66-3:16, 3:20-23, 20:35-37. "[W]hen the adaptive array antenna is adopted, it is necessary to know the station which transmits the CTS" to determine the weightings for the adaptive array antenna. *Id.* at 9:45-49. The traditional CTS signal protocol cannot solve this problem because it does not include an address of the station that transmits the CTS signal. *Id.* at Fig. 5, 9:20-31. Thus, "[a]n aspect of the present invention is to provide a new frame format instead of the frame format for the conventional wireless LAN." *Id.* at 3:28-34. Specifically, the patent explains that the new frame format for the CTS signal includes a newly added portion for a Transmitter Address TA, which "describes the address of the communication station transmitting the CTS signal." *Id.* at 10:40-50. This improved solution allows directional antennas to know which communication station(s) transmitted the clear to send signal for determining weightings for the adaptive array antenna and optimum directivity of transmissions to such station(s). *Id.* at 4:43-60, 7:42-49, 9:45-49. Additionally, the new frame format for the CTS

signals allows a first communication station to “receive a plurality of clear to send signals respectively transmitted from a plurality of second communication stations,” which makes it “possible to transmit data to a plurality of the communication stations at the same time.” *Id.* at 5:43-44. “Thus, this communication system can extremely increase a communication capacity of a network and thus can provide the application for transmitting a large capacity of data ... which is impossible in the conventional wireless LAN.” *Id.* at 20:16-21. The claims of the ’920 patent provide the specific improved format of the CTS signal that achieve the aforementioned results. Claim 13 recites that “the clear to send signal includes ... the second section including the address of the [communication station that transmits the CTS signal].” *Id.*, claim 13.

81. As shown above, the ’920 patent describes a specific problem to be solved in wireless signal communications in the context of traditional CTS signals with directional antennas, as well as a specific way of solving that problem by using a new frame format for CTS signals that identify the address of the communication station transmitting the CTS signals. This solution is directed to a specific improvement to the functionality of the communication itself and is further implemented in the claims, including claim 13.

82. The claims of the ’920 patent also survive step two of Alice because they recite an inventive concept that provides features that are more than well-understood, routine, conventional activity. For example, the ’920 patent explains that the claimed format of the CTS signal includes an additional field for an address of the communication station transmitting the CTS that was lacking in the conventional CTS signal. ’920 patent, 10:40-50.

83. At a minimum, Qualcomm has known of the ’920 patent at least as early as the filing date of the Complaint. In addition, Qualcomm has known about the ’920 patent since at least November 5, 2021, when Qualcomm and/or its agents received notice of its infringement of the

'920 patent via a letter. On December 7, 2021, Qualcomm received further notice of its infringement of the '920 patent when Qualcomm downloaded an infringement chart of the '920 patent via a data room provided by Redwood. Furthermore, Qualcomm has known about the '920 patent since at least May 12, 2022, when Qualcomm and/or its agents received further notice of its infringement via email. In addition, Qualcomm has had knowledge of the '920 patent based at least on its conduct before the USPTO. For example, the '920 patent was cited by the Examiner during the prosecution of the following patent documents assigned to Qualcomm: U.S. Patent Application Publication No. 2012/0076073 entitled "Protection Mechanisms For Multi-User MIMO Transmissions;" and U.S. Patent Application Publication No. 2012/0087316 entitled "Protection Mechanisms For Multi-User MIMO Transmissions."

84. On information and belief, since at least the above-mentioned dates when Qualcomm was on notice of its infringement, Qualcomm has actively induced, under U.S.C. § 271(b), distributors, customers, subsidiaries, importers, partners, affiliates, resellers, manufacturers, end users, and/or consumers that make, import, use, purchase, offer to sell, and/or sell the Accused Products comprising all of the limitations of one or more claims of the '920 patent to directly infringe one or more claims of the '920 patent by making, using, offering for sale, selling, and/or importing the Accused Products. Since at least the notice provided on the above-mentioned dates, Qualcomm does so with knowledge, or with willful blindness of the fact, that the induced acts constitute infringement of the '920 patent. Qualcomm intends to cause, and has taken affirmative steps to induce infringement by distributors, customers, subsidiaries, importers, partners, affiliates, resellers, manufacturers, end users, and/or consumers by at least, inter alia, creating advertisements that promote the infringing use of the Accused Products, creating and/or maintaining and/or knowledge of established distribution channels for the Accused Products into

and within the United States, manufacturing the Accused Products in conformity with U.S. laws and regulations, manufacturing the Accused Products in conformity with the relevant IEEE 802.11 standards, distributing or making available instructions or manuals for the Accused Products to purchasers and prospective buyers, providing the accused functionalities via hardware, software, and/or firmware that are included in the Accused Products to manufacturers, purchasers, sellers, distributors, and/or end users, testing and certifying features related to infringing features in the Accused Products, and/or providing technical support, replacement parts, or services for these products to these purchasers and/or sellers in the United States.

85. On information and belief, since at least the above-mentioned dates when Qualcomm was on notice of its infringement, Qualcomm's contributory infringement pursuant to 35 U.S.C. § 271(c) includes offering to sell and/or license, selling and/or licensing, and/or providing within the United States, or importing into the United States, components of the patented invention of one or more claims of the '920 patent, constituting a material part of the invention. On information and belief, Qualcomm knows and has known the same to be especially made or especially adapted for use in an infringement of the '920 patent, and such components are not a staple article or commodity of commerce suitable for substantial noninfringing use. For example, Qualcomm offers to sell, sells, and/or licenses or otherwise provides hardware and/or software/firmware components of the Accused Products within the United States; the components constitute a material part of the claimed inventions of the '920 patent that are especially made or especially adapted for use in end user products that infringe the '920 patent; and the components are not a staple article or commodity of commerce suitable for substantial noninfringing use.

86. On information and belief, since at least the above-mentioned dates when Qualcomm was on notice of its infringement, Qualcomm's infringement pursuant to 35 U.S.C. §

271(f)(1) includes supplying or causing to be supplied in or from the United States all or a substantial portion of the components of the patented invention of one or more claims of the '920 patent, where such components are uncombined in whole or in part, in such manner as to actively induce the combination of such components outside of the United States in a manner that would infringe the patent if such combination occurred within the United States. For example, Qualcomm supplies or causes to be supplied in or from the United States the hardware and/or software/firmware components of the Accused Products that comprise all or a substantial portion of the components of the patented inventions of the '920 patent, where Qualcomm actively induces the combination of such components outside of the United States in a manner that would infringe the patent if such combination occurred within the United States. In another example, Qualcomm supplies or causes to be supplied in or from the United States the hardware and/or software/firmware components of the Accused Products that comprise all or a substantial portion of the components of the patented inventions of the '920 patent, where Qualcomm actively induces the combination of the hardware and/or software/firmware components with other components of an end user device outside of the United States in a manner that would infringe the patent if such combination occurred within the United States. Qualcomm intends to cause, and has taken affirmative steps to induce infringement by distributors, customers, subsidiaries, importers, partners, affiliates, resellers, manufacturers, and/or consumers by at least, inter alia, creating advertisements that promote the infringing use of the Accused Products, creating and/or maintaining and/or knowledge of established distribution channels for the Accused Products into and within the United States, manufacturing the components of the Accused Products in conformity with U.S. laws and regulations, manufacturing the components of the Accused Products in conformity with the relevant IEEE 802.11 standards, distributing or making available

instructions or manuals or marketing materials regarding the combination of the hardware and software/firmware components, distributing or making available instructions or manuals or marketing materials regarding the combination of the hardware and/or software/firmware components with other components as part of making an end user device in part or in whole, testing and certifying features related to infringing features in the Accused Products, providing software and/or firmware for the Accused Products to manufacturers, purchasers, sellers, distributors, and/or end users, and/or providing technical support, replacement parts, or services for these products to these purchasers and/or sellers in the United States.

87. On information and belief, since at least the above-mentioned dates when Qualcomm was on notice of its infringement, Qualcomm's infringement pursuant to 35 U.S.C. § 271(f)(2) includes supplying or causing to be supplied in or from the United States components of the patented invention of one or more claims of the '920 patent that are especially made or especially adapted for use in the invention and not staple articles or commodities of commerce suitable for substantial noninfringing use, where such components are uncombined in whole or in part, knowing that such components are so made or adapted and intending that such components will be combined outside of the United States in a manner that would infringe the patent if such combination occurred within the United States. For example, Qualcomm supplies or causes to be supplied in or from the United States the hardware and/or software/firmware components that comprise all or a substantial portion of the components of the patented inventions of the '920 patent, where such components are uncombined in whole or in part, knowing that such components are especially made or especially adapted for use in the invention and not staple articles or commodities of commerce suitable for substantial noninfringing use and intending that such components will be combined outside of the United States in a manner that would infringe the

patent if such combination occurred within the United States. In another example, Qualcomm supplies or causes to be supplied in or from the United States the hardware and/or software/firmware components that comprise all or a substantial portion of the components of the patented inventions of the '920 patent, where such components are uncombined in whole or in part with other components of an end user device, knowing that such components are especially made or especially adapted for use in the invention and not staple articles or commodities of commerce suitable for substantial noninfringing use and intending that such components will be combined with other components of an end user device outside of the United States in a manner that would infringe the patent if such combination occurred within the United States.

88. On information and belief, despite having knowledge of the '920 patent and knowledge that it is directly and/or indirectly infringing one or more claims of the '920 patent, Qualcomm has nevertheless continued its infringing conduct and disregarded an objectively high likelihood of infringement. Qualcomm's infringing activities relative to the '920 patent have been, and continue to be, willful, wanton, malicious, in bad-faith, deliberate, consciously wrongful, flagrant, characteristic of a pirate, and an egregious case of misconduct beyond typical infringement such that Plaintiff is entitled under 35 U.S.C. § 284 to enhanced damages up to three times the amount found or assessed.

89. Redwood has been damaged as a result of Qualcomm's infringing conduct described in this Count. Qualcomm is, thus, liable to Redwood in an amount that adequately compensates Redwood for Qualcomm's infringements, which, by law, cannot be less than a reasonable royalty, together with interest and costs as fixed by this Court under 35 U.S.C. § 284.

COUNT IV

(INFRINGEMENT OF U.S. PATENT NO. 7,826,555)

90. Plaintiff incorporates paragraphs 1 through 89 herein by reference.

91. Redwood is the assignee of the '555 patent, entitled "MIMO-OFDM Transmission Device and MIMO-OFDM Transmission Method," with ownership of all substantial rights in the '555 patent, including the right to exclude others and to enforce, sue, and recover damages for past and future infringements.

92. The '555 patent is valid, enforceable, and was duly issued in full compliance with Title 35 of the United States Code. The '555 patent issued from U.S. Patent Application No. 11/577,791.

93. Qualcomm has and continues to directly and/or indirectly infringe one or more claims of the '555 patent in this judicial district and elsewhere in Texas and the United States.

94. Qualcomm directly infringes the '555 patent via 35 U.S.C. § 271(a) by making, using, offering for sale, selling, and/or importing the Accused Products, their components and processes, and/or products containing the same that incorporate the fundamental technologies covered by the '555 patent.

95. Furthermore, Defendants directly infringe the '555 patent through its direct involvement in the activities of its subsidiaries. Such subsidiaries conduct activities that constitute direct infringement of the '555 patent under 35 U.S.C. § 271(a) by making, using, offering for sale, selling, and/or importing those Accused Products, their components and processes, and/or products containing the same that incorporated the fundamental technologies covered by the '555 patent. Further, Defendants are vicariously liable for this infringing conduct of its subsidiaries (under both the alter ego and agency theories) because, as an example and on information and belief, Qualcomm Incorporated, QTI, and their subsidiaries and related companies are essentially the same company, and Qualcomm Incorporated and/or QTI have the right and ability to control their subsidiaries infringing acts and receive a direct financial benefit from the infringement of its

subsidiaries. Furthermore, on information and belief, Qualcomm sells and makes the Accused Products outside of the United States, delivers those products to manufacturers, customers, distributors, and/or subsidiaries in the United States, or in the case that it delivers the Accused Products outside of the United States it does so intending and/or knowing that those products or products that are manufactured to include Qualcomm's Accused Products are destined for the United States and/or designing those products for inclusion in other products to be placed on sale and used in the United States, thereby directly infringing the '555 patent. *See, e.g., Lake Cherokee Hard Drive Techs., L.L.C. v. Marvell Semiconductor, Inc.*, 964 F. Supp. 2d 653, 658 (E.D. Tex. 2013).

96. For example, Qualcomm infringes claim 1 of the '555 patent via the Accused Products, including the FastConnect 7800. The Accused Products, including the FastConnect 7800, each are compliant with IEEE 802.11n and/or IEEE 802.11ac and/or IEEE 802.11ax and/or IEEE 802.11be, and each comprise a MIMO-OFDM transmission apparatus that transmits OFDM-modulated data symbols from a plurality of antennas in a data transmission period and transmits pilot symbols from specific carriers of the plurality of antennas in the data transmission period. *See, e.g.,* <https://www.qualcomm.com/products/technology/wi-fi/fastconnect/fastconnect-7800> ("The Qualcomm FastConnect 7800 is an advanced 14nm Wi-Fi and Bluetooth® Connectivity system delivering ultra-high speeds;" "Standards: 802.11be, 802.11ax, 802.11ac, 802.11n, 802.11g, 802.11b, 802.11a;" "Antenna Configuration: 2x2;" and "Spatial Streams: Up to 4."). For example, each of the Accused Products, including the FastConnect 7800, comprise a MIMO-OFDM transmission apparatus that transmits OFDM data symbols from two or more antennas in a data transmission period, such that each transmitted OFDM symbol contains four pilot symbols, in a 20 MHz transmission, inserted in carrier positions -21, -7, 7, and 21. *See, e.g.,* Sections

17.3.5.9, 19.1.1, 19.1.2, and 19.3.11.10 and Equation 19-54 of IEEE 802.11 2016. In another example, the Accused Products transmit OFDM symbols and their corresponding pilot symbols in a data transmission period (*e.g.*, the 3.2 μ s DFT period). *See, e.g.*, Sections 19.3.6, 19.3.11.10, 19.3.21, 19.4.3, and Equation 19-90 of IEEE 802.11 2016.

97. The Accused Products, including the FastConnect 7800, each comprise an OFDM signal forming section that forms OFDM signals to be transmitted from the plurality of antennas. For example, the Accused Products form HT-mixed format PPDU signals into OFDM symbols to be transmitted from the two or more antennas. *See, e.g.*, Sections 19.1.1 and 19.3.4 of IEEE 802.11 2016.

98. The Accused Products, including the FastConnect 7800, each comprise a pilot symbol mapping section that assigns orthogonal sequences to same carriers of the OFDM signals of a same time period. For example, each of the Accused Products assigns orthogonal sequences to same carriers of the OFDM carriers of a same time period (*e.g.*, the 3.2 μ s DFT period) by inserting pilot symbols in carrier positions -21, -7, 7, and 21 in each OFDM symbol, such that each sequence of the four pilot symbols is orthogonal to a corresponding sequence in the OFDM symbols of another space-time stream. *See, e.g.*, Section 19.3.11.10 and Equation 19-54 of IEEE 802.11 2016.

99. When the OFDM signals are transmitted from two antennas of the Accused Products, including the FastConnect 7800, the pilot symbol mapping section of the Accused Products forms the pilot carriers such that pilot signals of orthogonal sequences are used for same pilot carriers between a first antenna and a second antenna. For example, when there are two space-time streams used for transmission by the Accused Products, the pilot sequences corresponding to stream one and stream two are orthogonal. *See, e.g.*, Table 19-19 of IEEE 802.11 2016.

100. When the OFDM signals are transmitted from two antennas of the Accused Products, including the FastConnect 7800, the pilot symbol mapping section of the Accused Products forms the pilot carriers such that pilot signals of different sequences are used for different pilot carriers at each of the first antenna and the second antenna. For example, within transmissions from each antenna, pilot values differ from one pilot subcarrier to another pilot subcarrier and pilot values corresponding to a given carrier repeat over OFDM symbols, such that pilot values corresponding to different subcarriers at each antenna are different. *See, e.g.*, Table 19-19 of IEEE 802.11 2016.

101. When the OFDM signals are transmitted from two antennas of the Accused Products, including the FastConnect 7800, the pilot symbol mapping section of the Accused Products, form the pilot carriers such that pilot signals of a same sequence are used at the first antenna and the second antenna. For example, a cyclically rotated version of a same sequence of pilot values (*e.g.*, 1, 1, -1, -1) is repeated for each of the two antennas. *See, e.g.*, Table 19-19 of IEEE 802.11 2016.

102. The specific ways in which the Accused Products, including the FastConnect 7800, are configured to support the aforementioned features of IEEE 802.11n and/or IEEE 802.11ac and/or IEEE 802.11ax and/or IEEE 802.11be are further detailed in confidential documents and/or source code that evidence infringement by the Accused Products as to Claim 1 of the '555 patent.

103. Furthermore, the Accused Products, including the FastConnect 7800, are configured or implemented in an infringing manner with the features and functionality recited in at least Claim 1 of the '555 patent.

104. The technology discussion above and the exemplary Accused Products provide context for Plaintiff's infringement allegations.

105. The claims of the '555 patent are patent eligible under 35 U.S.C. § 101. The '555 patent is not directed to an ineligible abstract idea. For example, it is not a mathematical algorithm executed on a generic computer or a fundamental economic business practice. Instead, the '555 patent describes specific problems in signal transmission and communication involving multiple-input multiple-output (MIMO) OFDM communications and its claims are directed to specific ways of solving those problems. '555 patent, 2:19-45. In summary, “sufficient consideration has not been given to the method of transmitting symbols for transmission path estimation and symbols for frequency offset estimation to realize high accuracy frequency offset estimation, high accuracy transmission path fluctuation estimation and high accuracy synchronization/signal detection” for MIMO-OFDM communications. *Id.* As the '555 patent explains, “the present invention relates to a technology for realizing an ideal symbol configuration for ... MIMO-OFDM communication” to provide high accuracy frequency offset estimation, high accuracy transmission path estimation, and high accuracy signal detection. '555 patent, 1:8-12. The '555 patent claims specific technical solutions that achieve the aforementioned improvements. *See, e.g.*, '555 patent, Claim 1.

106. Specifically, the '555 patent describes that “orthogonal sequences are assigned to corresponding subcarriers among OFDM signals transmitted at the same time from the respective antennas in the time domain to form pilot carriers, so that, even when pilot symbols are multiplexed among a plurality of channels (antennas), it is possible to estimate frequency offset/phase noise with high accuracy. Furthermore, since pilot symbols of each channel can be extracted without using a channel estimator value (transmission path fluctuation estimation value), it is possible to simplify the configuration of the section for compensating for the frequency offset/phase noise.” '555 patent, 2:60-3:3. These specific solutions are recited in claim 1 of the '555 patent. This allows MIMO OFDM systems and devices to estimate frequency offset and/or phase noise with high

accuracy even when pilot symbols are multiplexed on different channels. '555 patent, 10:56-60. In the conventional solution, when the same carriers of channel A and channel B are not orthogonal to each other, the estimation accuracy for frequency offset and/or phase noise by frequency offset/phase noise estimation decreases (signals become components of interference with each other), and therefore it is not possible to realize high accuracy frequency offset/phase noise compensation. '555 patent, 11:13-21. Furthermore, when a wireless LAN builds a system at the same frequency and in the same frequency band according to IEEE 802.11 and a spatial multiplexing MIMO system, this allows the frame configuration to be shared, and therefore it is possible to simplify the reception apparatus. '555 patent, 8:60-9:2. "Another important advantage is that since no channel estimation value (transmission path fluctuation estimation value) is required, it is possible to simplify the configuration of the part for compensating for the frequency offset and/or phase noise." '555 patent, 10:60-64. If pilot symbols of channel A and channel B are not orthogonal to each other, signal processing of MIMO demultiplexing is carried out, such that frequency offset and/or phase noise are then estimated. '555 patent, 10:64-11:3. On the other hand, when the claimed solutions are utilized, it is possible to compensate for frequency offset and/or phase noise before demultiplexing a signal. '555 patent, 11:3-7. In addition, the claimed solutions allow for the frequency offset and/or phase noise to be removed using pilot symbols even after demultiplexing the signal of channel A from the signal of channel B, thereby making it possible to compensate for the frequency offset and/or phase noise with higher accuracy. '555 patent, 11:7-12.

107. Furthermore, the '555 patent discloses additional improvements to symbol configurations for MIMO OFDM communications. Claim 1 of the '555 recites that "pilot signals of different sequences are used for different pilot carriers between a first antenna and a second

antenna” for the transmission of the OFDM signals at a same time period. According to this improved configuration, when MIMO OFDM transmissions are carried out using more than one antenna, it minimizes an increase of transmission peak without degrading estimation accuracy for frequency offset/phase noise. ’555 patent, 3:13-18, 10:1-7. Additionally, claim 1 of the ’555 patent utilizes pilot signals of the same sequence for each of the antennas that are transmitted and/or received by a MIMO OFDM device at a same time period, which results in high accuracy synchronization/signal detection by the receiving apparatus. ’555 patent, 14:39-48.

108. Thus, the ’555 patent describes problems to be solved in MIMO OFDM digital signal communications as well as specific solutions for solving those problems that are reflected in the claims, including claim 1.

109. The claims of the ’555 patent also survive step two of Alice because they recite an inventive concept that provides features that are more than well-understood, routine, conventional activity.

110. At a minimum, Qualcomm has known of the ’555 patent at least as early as the filing date of the Complaint. In addition, Qualcomm has known about the ’555 patent since at least November 5, 2021, when Qualcomm and/or its agents received notice of the ’555 patent via a letter. On January 31, 2022, Qualcomm received further notice of its infringement of the ’555 patent when Redwood provided an infringement chart of the ’555 patent via a data room that Qualcomm had access to and was regularly accessing. Furthermore, Qualcomm has known about the ’555 patent since at least May 12, 2022, when Qualcomm and/or its agents received further notice of its infringement via email. On information and belief, Qualcomm has also had knowledge of the ’555 patent based at least on its conduct before the USPTO. For example, at least one patent document related to the ’555 patent was cited by the Examiner during the prosecution of the

following patent documents assigned to Qualcomm: U.S. Patent No. 8,978,103 entitled “Method And Apparatus For Interworking Authorization Of Dual Stack Operation;” U.S. Patent No. 8,174,995 entitled “Method And Apparatus For Flexible Pilot Pattern;” and U.S. Patent No. 10,439,663 entitled “Method And Apparatus For Phase Noise Estimation In Data Symbols For Millimeter Wave Communications.”

111. On information and belief, since at least the above-mentioned dates when Qualcomm was on notice of its infringement, Qualcomm has actively induced, under U.S.C. § 271(b), distributors, customers, subsidiaries, importers, partners, affiliates, resellers, manufacturers, end users, and/or consumers that make, import, use, purchase, offer to sell, and/or sell the Accused Products comprising all of the limitations of one or more claims of the ’555 patent to directly infringe one or more claims of the ’555 patent by making, using, offering for sale, selling, and/or importing the Accused Products. Since at least the notice provided on the above-mentioned dates, Qualcomm does so with knowledge, or with willful blindness of the fact, that the induced acts constitute infringement of the ’555 patent. Qualcomm intends to cause, and has taken affirmative steps to induce infringement by distributors, customers, subsidiaries, importers, partners, affiliates, resellers, manufacturers, end users, and/or consumers by at least, inter alia, creating advertisements that promote the infringing use of the Accused Products, creating and/or maintaining and/or knowledge of established distribution channels for the Accused Products into and within the United States, manufacturing the Accused Products in conformity with U.S. laws and regulations, manufacturing the Accused Products in conformity with the relevant IEEE 802.11 standards, distributing or making available instructions or manuals for the Accused Products to purchasers and prospective buyers, providing the accused functionalities via hardware, software, and/or firmware that are included in the Accused Products to manufacturers, purchasers, sellers,

distributors, and/or end users, testing and certifying features related to infringing features in the Accused Products, and/or providing technical support, replacement parts, or services for these products to these purchasers and/or sellers in the United States.

112. On information and belief, since at least the above-mentioned dates when Qualcomm was on notice of its infringement, Qualcomm's contributory infringement pursuant to 35 U.S.C. § 271(c) includes offering to sell and/or license, selling and/or licensing, and/or providing within the United States, or importing into the United States, components of the patented invention of one or more claims of the '555 patent, constituting a material part of the invention. On information and belief, Qualcomm knows and has known the same to be especially made or especially adapted for use in an infringement of the '555 patent, and such components are not a staple article or commodity of commerce suitable for substantial noninfringing use. For example, Qualcomm offers to sell, sells, and/or licenses or otherwise provides hardware and/or software/firmware components of the Accused Products within the United States; the components constitute a material part of the claimed inventions of the '555 patent that are especially made or especially adapted for use in end user products that infringe the '555 patent; and the components are not a staple article or commodity of commerce suitable for substantial noninfringing use.

113. On information and belief, since at least the above-mentioned dates when Qualcomm was on notice of its infringement, Qualcomm's infringement pursuant to 35 U.S.C. § 271(f)(1) includes supplying or causing to be supplied in or from the United States all or a substantial portion of the components of the patented invention of one or more claims of the '555 patent, where such components are uncombined in whole or in part, in such manner as to actively induce the combination of such components outside of the United States in a manner that would infringe the patent if such combination occurred within the United States. For example, Qualcomm

supplies or causes to be supplied in or from the United States the hardware and/or software/firmware components of the Accused Products that comprise all or a substantial portion of the components of the patented inventions of the '555 patent, where Qualcomm actively induces the combination of such components outside of the United States in a manner that would infringe the patent if such combination occurred within the United States. In another example, Qualcomm supplies or causes to be supplied in or from the United States the hardware and/or software/firmware components of the Accused Products that comprise all or a substantial portion of the components of the patented inventions of the '555 patent, where Qualcomm actively induces the combination of the hardware and/or software/firmware components with other components of an end user device outside of the United States in a manner that would infringe the patent if such combination occurred within the United States. Qualcomm intends to cause, and has taken affirmative steps to induce infringement by distributors, customers, subsidiaries, importers, partners, affiliates, resellers, manufacturers, and/or consumers by at least, inter alia, creating advertisements that promote the infringing use of the Accused Products, creating and/or maintaining and/or knowledge of established distribution channels for the Accused Products into and within the United States, manufacturing the components of the Accused Products in conformity with U.S. laws and regulations, manufacturing the components of the Accused Products in conformity with the relevant IEEE 802.11 standards, distributing or making available instructions or manuals or marketing materials regarding the combination of the hardware and software/firmware components, distributing or making available instructions or manuals or marketing materials regarding the combination of the hardware and/or software/firmware components with other components as part of making an end user device in part or in whole, testing and certifying features related to infringing features in the Accused Products, providing software

and/or firmware for the Accused Products to manufacturers, purchasers, sellers, distributors, and/or end users, and/or providing technical support, replacement parts, or services for these products to these purchasers and/or sellers in the United States.

114. On information and belief, since at least the above-mentioned dates when Qualcomm was on notice of its infringement, Qualcomm's infringement pursuant to 35 U.S.C. § 271(f)(2) includes supplying or causing to be supplied in or from the United States components of the patented invention of one or more claims of the '555 patent that are especially made or especially adapted for use in the invention and not staple articles or commodities of commerce suitable for substantial noninfringing use, where such components are uncombined in whole or in part, knowing that such components are so made or adapted and intending that such components will be combined outside of the United States in a manner that would infringe the patent if such combination occurred within the United States. For example, Qualcomm supplies or causes to be supplied in or from the United States the hardware and/or software/firmware components that comprise all or a substantial portion of the components of the patented inventions of the '555 patent, where such components are uncombined in whole or in part, knowing that such components are especially made or especially adapted for use in the invention and not staple articles or commodities of commerce suitable for substantial noninfringing use and intending that such components will be combined outside of the United States in a manner that would infringe the patent if such combination occurred within the United States. In another example, Qualcomm supplies or causes to be supplied in or from the United States the hardware and/or software/firmware components that comprise all or a substantial portion of the components of the patented inventions of the '555 patent, where such components are uncombined in whole or in part with other components of an end user device, knowing that such components are especially made

or especially adapted for use in the invention and not staple articles or commodities of commerce suitable for substantial noninfringing use and intending that such components will be combined with other components of an end user device outside of the United States in a manner that would infringe the patent if such combination occurred within the United States.

115. On information and belief, despite having knowledge of the '555 patent and knowledge that it is directly and/or indirectly infringing one or more claims of the '555 patent, Qualcomm has nevertheless continued its infringing conduct and disregarded an objectively high likelihood of infringement. Qualcomm's infringing activities relative to the '555 patent have been, and continue to be, willful, wanton, malicious, in bad-faith, deliberate, consciously wrongful, flagrant, characteristic of a pirate, and an egregious case of misconduct beyond typical infringement such that Plaintiff is entitled under 35 U.S.C. § 284 to enhanced damages up to three times the amount found or assessed.

116. Redwood has been damaged as a result of Qualcomm's infringing conduct described in this Count. Qualcomm is, thus, liable to Redwood in an amount that adequately compensates Redwood for Qualcomm's infringements, which, by law, cannot be less than a reasonable royalty, together with interest and costs as fixed by this Court under 35 U.S.C. § 284.

COUNT V

(INFRINGEMENT OF U.S. PATENT NO. 7,983,140)

117. Plaintiff incorporates paragraphs 1 through 116 herein by reference.

118. Redwood is the assignee of the '140 patent, entitled "Transmitting Apparatus, Receiving Apparatus, and Communication System for Formatting Data," with ownership of all substantial rights in the '140 patent, including the right to exclude others and to enforce, sue, and recover damages for past and future infringements.

119. The '140 patent is valid, enforceable, and was duly issued in full compliance with Title 35 of the United States Code. The '140 patent issued from U.S. Patent Application No. 11/004,256.

120. Qualcomm has and continues to directly and/or indirectly infringe one or more claims of the '140 patent in this judicial district and elsewhere in Texas and the United States.

121. Qualcomm directly infringes the '140 patent via 35 U.S.C. § 271(a) by making, using, offering for sale, selling, and/or importing the Accused Products, their components and processes, and/or products containing the same that incorporate the fundamental technologies covered by the '140 patent.

122. Furthermore, Defendants directly infringe the '140 patent through its direct involvement in the activities of its subsidiaries. Such subsidiaries conduct activities that constitute direct infringement of the '140 patent under 35 U.S.C. § 271(a) by making, using, offering for sale, selling, and/or importing those Accused Products, their components and processes, and/or products containing the same that incorporated the fundamental technologies covered by the '140 patent. Further, Defendants are vicariously liable for this infringing conduct of its subsidiaries (under both the alter ego and agency theories) because, as an example and on information and belief, Qualcomm Incorporated, QTI, and their subsidiaries and related companies are essentially the same company, and Qualcomm Incorporated and/or QTI have the right and ability to control their subsidiaries infringing acts and receive a direct financial benefit from the infringement of its subsidiaries. Furthermore, on information and belief, Qualcomm sells and makes the Accused Products outside of the United States, delivers those products to manufacturers, customers, distributors, and/or subsidiaries in the United States, or in the case that it delivers the Accused Products outside of the United States it does so intending and/or knowing that those products or

products that are manufactured to include Qualcomm's Accused Products are destined for the United States and/or designing those products for inclusion in other products to be placed on sale and used in the United States, thereby directly infringing the '140 patent. *See, e.g., Lake Cherokee Hard Drive Techs., L.L.C. v. Marvell Semiconductor, Inc.*, 964 F. Supp. 2d 653, 658 (E.D. Tex. 2013).

123. For example, Qualcomm infringes claim 1 of the '140 patent via the Accused Products, including the FastConnect 7800. The Accused Products, including the FastConnect 7800, comprise a transmitting apparatus, in an orthogonal frequency division multiplexing communication system. *See, e.g.,* <https://www.qualcomm.com/products/technology/wi-fi/fastconnect/fastconnect-7800> ("The Qualcomm FastConnect 7800 is an advanced 14nm Wi-Fi and Bluetooth® Connectivity system delivering ultra-high speeds;" "Standards: 802.11be, 802.11ax, 802.11ac, 802.11n, 802.11g, 802.11b, 802.11a;" "Antenna Configuration: 2x2;" and "Spatial Streams: Up to 4.").

124. The Accused Products, including the FastConnect 7800, each comprise circuitry and/or components (hardware and/or software) for converting a transmission signal into a transmission time slot. For example, the Accused Products, including the FastConnect 7800, convert PSDUs into PPDU. *See, e.g.,* Sections 17.3.1 and 17.3.2.1 of IEEE 802.11 2016.

125. The Accused Products, including the FastConnect 7800, each comprise circuitry and/or components (hardware and/or software) for generating a frame that includes a series of n (greater than 1) time slots and a frame guard period added to the series of n time slots, where each time slot includes an effective symbol period and guard period added to the effective symbol period, where the length of the series of n time slots is less than the length of the frame. For example, each of the Accused Products, including the FastConnect 7800, generates a PDU frame

that comprises a series of time slots associated with the signal and data OFDM symbols. *See, e.g.*, Figures 17-1 and 17-4 of IEEE 802.11 2016. Each of the Accused Products, including the FastConnect 7800, generates cyclic shifts that are added to the series of n time slots. *See, e.g.*, Sections 19.3.4 and 19.3.9.3.2 of IEEE 802.11 2016. Each time slot in the PPDU frame comprises an effective symbol period, and a guard period is added at the start of each effective symbol period. *See, e.g.*, Table 19-6 and Figure 17-4 of IEEE 802.11 2016. Further, the length of the series of n time slots is less than the total length of the PPDU frame. *See, e.g.*, Figure 17-4 of IEEE 802.11 2016.

126. The Accused Products, including the FastConnect 7800, each comprise circuitry and/or components (hardware and/or software) for transmitting the generated frame as a radio signal. *See, e.g.*, Section 17.3.8.2 of IEEE 802.11 2016.

127. The specific ways in which the Accused Products, including the FastConnect 7800, are configured to support the aforementioned features of IEEE 802.11n and/or IEEE 802.11ac and/or IEEE 802.11ax and/or IEEE 802.11be are further detailed in confidential documents and/or source code that evidence infringement by the Accused Products as to at least Claim 1 of the '140 patent.

128. Furthermore, the Accused Products, including the FastConnect 7800, are configured or implemented in an infringing manner with the features and functionality recited in at least Claim 1 of the '140 patent.

129. The technology discussion above and the exemplary Accused Products provide context for Plaintiff's infringement allegations.

130. The claims of the '140 Patent are patent eligible under 35 U.S.C. § 101. The '140 patent is not directed to an ineligible abstract idea. For example, it is not a mathematical algorithm

executed on a generic computer or a fundamental economic business practice. Instead, it is a technologically complex, particularized method of signal conversion and transmission. The '140 patent explains a problem that exists in cellular networks, namely that different cells transmitting in the same frequency will interfere with each other. *See, e.g.*, '140 patent, 1:30-32. That interference can be solved by having the different cells use different frequencies, but that solution causes another problem, i.e., decreased spectrum efficiency. *See, e.g.*, '140 patent, 1:30-44. Thus, '140 patent explains, "it is important to design a communication system such that the system has high resistance against interference thereby achieving an improvement in the spectrum efficiency". '140 patent, 1:45-47.

131. The '140 patent provides a technical solution to that technical problem by implementing "an improvement in a format of data that is modulated and transmitted using, for example, an OFDM (Orthogonal Frequency Division Multiplexing) technique." '140 patent, 1:14-17. The claims of the '140 patent provide for a specific format of transmission for that purpose. For example, the "frame" in claim 1 includes a "a frame guard period added to the series of n time slots." As the '140 Patent explains, when "no frame guard is used, the interfering wave IFW interferes with two frames of the desired wave DSW. In contrast, in the communication system according to the present embodiment of the invention, a frame guard included in an OFDM signal prevents the interfering wave IFW from interfering with the second frame, as shown in FIGS. 15(A) and 15(B)." '140 Patent, 18:63-19:2. This helps achieve the goal of the of the '140 patent of "suppression of a frame loss due to interference caused by use of the same channel." *Id.* at 3:32-33. Thus, the claimed transmission apparatus uses a transmission format designed to add efficiency to the transmission process in a particular manner. As such, the recited transmission apparatus is a concrete technical contribution and not simply the embodiment of an abstract idea.

132. At a minimum, Qualcomm has known of the '140 patent at least as early as the filing date of the Complaint. In addition, Qualcomm has known about the '140 patent since at least November 5, 2021, when Qualcomm and/or its agents received notice of its infringement of the '140 patent via a letter. On December 7, 2021, Qualcomm received further notice of its infringement of the '140 patent when Qualcomm downloaded an infringement chart of the '140 patent via a data room provided by Redwood. Furthermore, Qualcomm has known about the '140 patent since at least May 12, 2022, when Qualcomm and/or its agents received further notice of its infringement via email. On information and belief, Qualcomm has had knowledge of the '140 patent based at least on its conduct before the USPTO. For example, at least one patent document related to the '140 patent was cited by the Examiner during the prosecution of U.S. Patent No. 9,059,785 entitled "Fast Timing Acquisition In Cell Search" and assigned to Qualcomm.

133. On information and belief, since at least the above-mentioned dates when Qualcomm was on notice of its infringement, Qualcomm has actively induced, under U.S.C. § 271(b), distributors, customers, subsidiaries, importers, partners, affiliates, resellers, manufacturers, end users, and/or consumers that make, import, use, purchase, offer to sell, and/or sell the Accused Products comprising all of the limitations of one or more claims of the '140 patent to directly infringe one or more claims of the '140 patent by making, using, offering for sale, selling, and/or importing the Accused Products. Since at least the notice provided on the above-mentioned dates, Qualcomm does so with knowledge, or with willful blindness of the fact, that the induced acts constitute infringement of the '140 patent. Qualcomm intends to cause, and has taken affirmative steps to induce infringement by distributors, customers, subsidiaries, importers, partners, affiliates, resellers, manufacturers, end users, and/or consumers by at least, inter alia, creating advertisements that promote the infringing use of the Accused Products, creating and/or

maintaining and/or knowledge of established distribution channels for the Accused Products into and within the United States, manufacturing the Accused Products in conformity with U.S. laws and regulations, manufacturing the Accused Products in conformity with the relevant IEEE 802.11 standards, distributing or making available instructions or manuals for the Accused Products to purchasers and prospective buyers, providing the accused functionalities via hardware, software, and/or firmware that are included in the Accused Products to manufacturers, purchasers, sellers, distributors, and/or end users, testing and certifying features related to infringing features in the Accused Products, and/or providing technical support, replacement parts, or services for these products to these purchasers and/or sellers in the United States.

134. On information and belief, since at least the above-mentioned dates when Qualcomm was on notice of its infringement, Qualcomm's contributory infringement pursuant to 35 U.S.C. § 271(c) includes offering to sell and/or license, selling and/or licensing, and/or providing within the United States, or importing into the United States, components of the patented invention of one or more claims of the '140 patent, constituting a material part of the invention. On information and belief, Qualcomm knows and has known the same to be especially made or especially adapted for use in an infringement of the '140 patent, and such components are not a staple article or commodity of commerce suitable for substantial noninfringing use. For example, Qualcomm offers to sell, sells, and/or licenses or otherwise provides hardware and/or software/firmware components of the Accused Products within the United States; the components constitute a material part of the claimed inventions of the '140 patent that are especially made or especially adapted for use in end user products that infringe the '140 patent; and the components are not a staple article or commodity of commerce suitable for substantial noninfringing use.

135. On information and belief, since at least the above-mentioned dates when Qualcomm was on notice of its infringement, Qualcomm's infringement pursuant to 35 U.S.C. § 271(f)(1) includes supplying or causing to be supplied in or from the United States all or a substantial portion of the components of the patented invention of one or more claims of the '140 patent, where such components are uncombined in whole or in part, in such manner as to actively induce the combination of such components outside of the United States in a manner that would infringe the patent if such combination occurred within the United States. For example, Qualcomm supplies or causes to be supplied in or from the United States the hardware and/or software/firmware components of the Accused Products that comprise all or a substantial portion of the components of the patented inventions of the '140 patent, where Qualcomm actively induces the combination of such components outside of the United States in a manner that would infringe the patent if such combination occurred within the United States. In another example, Qualcomm supplies or causes to be supplied in or from the United States the hardware and/or software/firmware components of the Accused Products that comprise all or a substantial portion of the components of the patented inventions of the '140 patent, where Qualcomm actively induces the combination of the hardware and/or software/firmware components with other components of an end user device outside of the United States in a manner that would infringe the patent if such combination occurred within the United States. Qualcomm intends to cause, and has taken affirmative steps to induce infringement by distributors, customers, subsidiaries, importers, partners, affiliates, resellers, manufacturers, and/or consumers by at least, inter alia, creating advertisements that promote the infringing use of the Accused Products, creating and/or maintaining and/or knowledge of established distribution channels for the Accused Products into and within the United States, manufacturing the components of the Accused Products in

conformity with U.S. laws and regulations, manufacturing the components of the Accused Products in conformity with the relevant IEEE 802.11 standards, distributing or making available instructions or manuals or marketing materials regarding the combination of the hardware and software/firmware components, distributing or making available instructions or manuals or marketing materials regarding the combination of the hardware and/or software/firmware components with other components as part of making an end user device in part or in whole, testing and certifying features related to infringing features in the Accused Products, providing software and/or firmware for the Accused Products to manufacturers, purchasers, sellers, distributors, and/or end users, and/or providing technical support, replacement parts, or services for these products to these purchasers and/or sellers in the United States.

136. On information and belief, since at least the above-mentioned dates when Qualcomm was on notice of its infringement, Qualcomm's infringement pursuant to 35 U.S.C. § 271(f)(2) includes supplying or causing to be supplied in or from the United States components of the patented invention of one or more claims of the '140 patent that are especially made or especially adapted for use in the invention and not staple articles or commodities of commerce suitable for substantial noninfringing use, where such components are uncombined in whole or in part, knowing that such components are so made or adapted and intending that such components will be combined outside of the United States in a manner that would infringe the patent if such combination occurred within the United States. For example, Qualcomm supplies or causes to be supplied in or from the United States the hardware and/or software/firmware components that comprise all or a substantial portion of the components of the patented inventions of the '140 patent, where such components are uncombined in whole or in part, knowing that such components are especially made or especially adapted for use in the invention and not staple articles or

commodities of commerce suitable for substantial noninfringing use and intending that such components will be combined outside of the United States in a manner that would infringe the patent if such combination occurred within the United States. In another example, Qualcomm supplies or causes to be supplied in or from the United States the hardware and/or software/firmware components that comprise all or a substantial portion of the components of the patented inventions of the '140 patent, where such components are uncombined in whole or in part with other components of an end user device, knowing that such components are especially made or especially adapted for use in the invention and not staple articles or commodities of commerce suitable for substantial noninfringing use and intending that such components will be combined with other components of an end user device outside of the United States in a manner that would infringe the patent if such combination occurred within the United States.

137. On information and belief, despite having knowledge of the '140 patent and knowledge that it is directly and/or indirectly infringing one or more claims of the '140 patent, Qualcomm has nevertheless continued its infringing conduct and disregarded an objectively high likelihood of infringement. Qualcomm's infringing activities relative to the '140 patent have been, and continue to be, willful, wanton, malicious, in bad-faith, deliberate, consciously wrongful, flagrant, characteristic of a pirate, and an egregious case of misconduct beyond typical infringement such that Plaintiff is entitled under 35 U.S.C. § 284 to enhanced damages up to three times the amount found or assessed.

138. Redwood has been damaged as a result of Qualcomm's infringing conduct described in this Count. Qualcomm is, thus, liable to Redwood in an amount that adequately compensates Redwood for Qualcomm's infringements, which, by law, cannot be less than a reasonable royalty, together with interest and costs as fixed by this Court under 35 U.S.C. § 284.

COUNT VI

(INFRINGEMENT OF U.S. PATENT NO. 8,218,501)

139. Plaintiff incorporates paragraphs 1 through 138 herein by reference.

140. Redwood is the assignee of the '501 patent, entitled "Data Forwarding Controller, Communication Terminal Apparatus, Data Communication System and Method, and Computer Program for Performing Handover for a Mobile Node," with ownership of all substantial rights in the '501 patent, including the right to exclude others and to enforce, sue, and recover damages for past and future infringements.

141. The '501 patent is valid, enforceable, and was duly issued in full compliance with Title 35 of the United States Code. The '501 patent issued from U.S. Patent Application No. 12/116,779.

142. Qualcomm has and continues to directly and/or indirectly infringe one or more claims of the '501 patent in this judicial district and elsewhere in Texas and the United States.

143. Qualcomm directly infringes the '501 patent via 35 U.S.C. § 271(a) by making, using, offering for sale, selling, and/or importing the Accused Products, their components and processes, and/or products containing the same that incorporate the fundamental technologies covered by the '501 patent.

144. Furthermore, Defendants directly infringe the '501 patent through its direct involvement in the activities of its subsidiaries. Such subsidiaries conduct activities that constitute direct infringement of the '501 patent under 35 U.S.C. § 271(a) by making, using, offering for sale, selling, and/or importing those Accused Products, their components and processes, and/or products containing the same that incorporated the fundamental technologies covered by the '501 patent. Further, Defendants are vicariously liable for this infringing conduct of its subsidiaries (under both the alter ego and agency theories) because, as an example and on information and belief,

Qualcomm Incorporated, QTI, and their subsidiaries and related companies are essentially the same company, and Qualcomm Incorporated and/or QTI have the right and ability to control their subsidiaries infringing acts and receive a direct financial benefit from the infringement of its subsidiaries. Furthermore, on information and belief, Qualcomm sells and makes the Accused Products outside of the United States, delivers those products to manufacturers, customers, distributors, and/or subsidiaries in the United States, or in the case that it delivers the Accused Products outside of the United States it does so intending and/or knowing that those products or products that are manufactured to include Qualcomm's Accused Products are destined for the United States and/or designing those products for inclusion in other products to be placed on sale and used in the United States, thereby directly infringing the '501 patent. *See, e.g., Lake Cherokee Hard Drive Techs., L.L.C. v. Marvell Semiconductor, Inc.*, 964 F. Supp. 2d 653, 658 (E.D. Tex. 2013).

145. For example, Qualcomm infringes claim 1 of the '501 patent via the Accused Products, including the Snapdragon 712 Mobile Platform. The Accused Products, including the Snapdragon 712 Mobile Platform, are compliant with IEEE 802.11k and/or IEEE 802.11r and comprise a mobile communication terminal apparatus which performs data transmission/reception via a network and which changes access points based on data receiving conditions. *See, e.g.*, Figure 13-5 of IEEE 802.11 2016; https://www.qualcomm.com/content/dam/qcomm-martech/dm-assets/documents/prod_brief_qcom_sd712_0.pdf (evidencing that the Snapdragon 712 Mobile Platform is compliant with IEEE 802.11k, IEEE 802.11r, and IEEE 802.11v, where such compliance provides “[e]nhanced mobility, fast acquisition and congestion mitigation for carrier Wi-Fi”).

146. The Accused Products, including the Snapdragon 712 Mobile Platform, each comprise circuitry and/or components (hardware and/or software) configured to acquire a MAC address of a next access point to which the Accused Products are scheduled to be connected next after a handover from a current access point, and broadcast a handover start message containing the acquired MAC address of the next access point. For example, each of the Accused Products are configured to scan for beacon frames from neighborhood access points in a Neighbor Report element comprising the BSSID and BSSID information of neighborhood access points capable of Fast BSS Transition, where the Accused Products are configured to acquire the BSSID and BSSID information of a received beacon of a target access point to be connected to next after a handover from a current access point. *See, e.g.*, Figures 9-295, 9-296, 13-5 and Sections 9.4.2.37, 11.11.10.2, 11.11.10.3, and 13.3 of IEEE 802.11 2016. Further, each of the Accused Products are configured to broadcast a start message requesting a handover that comprises the BSSID of the target access point. *See, e.g.*, Figure 13-5 and Section 13.5.3 of IEEE 802.11 2016.

147. The Accused Products, including the Snapdragon 712 Mobile Platform, each comprise circuitry and/or components (hardware and/or software) configured to perform a handover process on condition that the Accused Products receive a handover setting completion message from a data forwarding controller as a response to the handover start message. For example, each of the Accused Products are configured to receive a handover setting completion message from a station management entity (“SME”) of the target access point in response to the handover start message, where the Accused Products are configured to perform a handover after receiving the handover setting completion message. *See, e.g.*, Figure 13-6 and Sections 9.4.1.9, 13.5.3, and 13.8.3 of IEEE 802.11 2016.

148. The Accused Products, including the Snapdragon 712 Mobile Platform, each comprise circuitry and/or components (hardware and/or software) configured to perform a background scanning process by which all wireless channels are periodically scanned to acquire and store a source MAC address of a received beacon as the MAC address of the next access point. For example, each of the Accused Products are configured to periodically scan for beacon frames from neighborhood access points in a Neighbor Report element comprising the BSSID and BSSID information of neighborhood access points capable of Fast BSS Transition, where the Accused Products are configured to acquire and store the BSSID and BSSID information of a received beacon of the target access point. *See, e.g.*, Figures 9-295, 9-296, 13-5 and Sections 9.4.2.37, 11.11.10.2, 11.11.10.3, and 13.3 of IEEE 802.11 2016.

149. The specific ways in which the Accused Products, including the Snapdragon 712 Mobile Platform, are configured to support the aforementioned features of IEEE 802.11k and/or IEEE 802.11r are further detailed in confidential documents and/or source code that evidence infringement by the Accused Products as to Claim 1 of the '501 patent.

150. Furthermore, the Accused Products, including the Snapdragon 712 Mobile Platform, are configured or implemented in an infringing manner with the features and functionality recited in at least Claim 1 of the '501 patent.

151. The technology discussion above and the exemplary Accused Products provide context for Plaintiff's infringement allegations.

152. The claims of the '501 patent are patent eligible under 35 U.S.C. § 101. The '501 patent is not directed to an ineligible abstract idea. For example, it is not a mathematical algorithm executed on a generic computer or a fundamental economic business practice. Instead, the '501 patent describes a specific problem to be solved in digital signal transmission and communication

directed to uninterrupted communications even when a mobile device moves between access points and its claims are directed to specific ways of solving that problem. '501 patent, 1:25-28. The conventional solutions directed to this problem could not support sufficiently high-speed handovers, because those solutions required devices to perform a plurality of processes that must be sequentially performed. '501 patent, 1:15-27. Furthermore, during these processes of the conventional solutions, the switch left the entry of the MAC address of the mobile node unupdated, thereby resulting in the switch forwarding its received data packets addressed to the mobile node to the old access point to which the mobile node was connected before its movement. *Id.*

153. To overcome the aforementioned problems, the '501 patent and its claims describe specific solutions for uninterrupted communications even when a mobile device moves between access points. "A second aspect of the present invention provides a communication terminal apparatus of a mobile type which performs data transmission/reception via a network and which changes access points based on data receiving conditions." '501 patent, 4:41-53. "The communication terminal apparatus is configured to acquire a MAC address of a next access point to which the communication terminal apparatus is scheduled to be connected next, and broadcast a handover start message containing the acquired MAC address of the next access point, and perform a handover process on condition that the communication terminal apparatus receives a handover setting completion message from a data forwarding controller as a response to the handover start message." *Id.* The claimed inventions of the '501 patent, including claim 1, are directed to this specific solution. "In an embodiment of the communication terminal apparatus of the present invention, the communication terminal apparatus is configured to perform a background scanning process by which all wireless channels are periodically scanned, to acquire and store a source MAC address of a received beacon as the MAC address of the next access

point.” ’501 patent, 4:54-59. The claimed inventions of the ’501 patent, including claim 1, are directed to this specific solution.

154. Furthermore, the claimed inventions of the ’501 patent, including claim 1, provide a solution of reducing traffic on the network to improve data transmissions by utilizing a handover end message that allows for the original access point to stop forwarding data packets addressed to the mobile device that has been handed over to a new access point. ’501 patent, claim 1, 8:25-34.

155. The ’501 patent describes a specific problem to be solved for uninterrupted communications even when a mobile device moves between access points and specific ways of solving that problem. Those solutions are further implemented in the claims, including claim 1. Therefore, the claims of ’501 patent are patent eligible. In addition, the claims of the ’501 patent are directed to solving problems that solely arise in mobile computer technology (digital signal communication and transmission) via specific improvements to its operation. As such, they are not patent ineligible abstract ideas.

156. The claims also survive step two of Alice because they recite an inventive concept that provides features that are more than well-understood, routine, conventional activity.

157. At a minimum, Qualcomm has known of the ’501 patent at least as early as the filing date of the Complaint. In addition, Qualcomm has known about the ’501 patent since at least November 5, 2021, when Qualcomm and/or its agents received notice of its infringement of the ’501 patent via a letter. On December 7, 2021, Qualcomm received further notice of its infringement of the ’501 patent when Qualcomm downloaded an infringement chart of the ’501 patent via a data room provided by Redwood. Furthermore, Qualcomm has known about the ’501 patent since at least May 12, 2022, when Qualcomm and/or its agents received further notice of its infringement via email. On information and belief, Qualcomm has had knowledge of the ’501

patent based at least on its conduct before the USPTO. For example, at least one patent document related to the '501 patent was cited by the Examiner during the prosecution of U.S. Patent No. 10,917,829 entitled "Path Handover In Bluetooth Mesh Routing" and assigned to Qualcomm.

158. On information and belief, since at least the above-mentioned dates when Qualcomm was on notice of its infringement, Qualcomm has actively induced, under U.S.C. § 271(b), distributors, customers, subsidiaries, importers, partners, affiliates, resellers, manufacturers, end users, and/or consumers that make, import, use, purchase, offer to sell, and/or sell the Accused Products comprising all of the limitations of one or more claims of the '501 patent to directly infringe one or more claims of the '501 patent by making, using, offering for sale, selling, and/or importing the Accused Products. Since at least the notice provided on the above-mentioned dates, Qualcomm does so with knowledge, or with willful blindness of the fact, that the induced acts constitute infringement of the '501 patent. Qualcomm intends to cause, and has taken affirmative steps to induce infringement by distributors, customers, subsidiaries, importers, partners, affiliates, resellers, manufacturers, end users, and/or consumers by at least, inter alia, creating advertisements that promote the infringing use of the Accused Products, creating and/or maintaining and/or knowledge of established distribution channels for the Accused Products into and within the United States, manufacturing the Accused Products in conformity with U.S. laws and regulations, manufacturing the Accused Products in conformity with the relevant IEEE 802.11 standards, distributing or making available instructions or manuals for the Accused Products to purchasers and prospective buyers, providing the accused functionalities via hardware, software, and/or firmware that are included in the Accused Products to manufacturers, purchasers, sellers, distributors, and/or end users, testing and certifying features related to infringing features in the

Accused Products, and/or providing technical support, replacement parts, or services for these products to these purchasers and/or sellers in the United States.

159. On information and belief, since at least the above-mentioned dates when Qualcomm was on notice of its infringement, Qualcomm's contributory infringement pursuant to 35 U.S.C. § 271(c) includes offering to sell and/or license, selling and/or licensing, and/or providing within the United States, or importing into the United States, components of the patented invention of one or more claims of the '501 patent, constituting a material part of the invention. On information and belief, Qualcomm knows and has known the same to be especially made or especially adapted for use in an infringement of the '501 patent, and such components are not a staple article or commodity of commerce suitable for substantial noninfringing use. For example, Qualcomm offers to sell, sells, and/or licenses or otherwise provides hardware and/or software/firmware components of the Accused Products within the United States; the components constitute a material part of the claimed inventions of the '501 patent that are especially made or especially adapted for use in end user products that infringe the '501 patent; and the components are not a staple article or commodity of commerce suitable for substantial noninfringing use.

160. On information and belief, since at least the above-mentioned dates when Qualcomm was on notice of its infringement, Qualcomm's infringement pursuant to 35 U.S.C. § 271(f)(1) includes supplying or causing to be supplied in or from the United States all or a substantial portion of the components of the patented invention of one or more claims of the '501 patent, where such components are uncombined in whole or in part, in such manner as to actively induce the combination of such components outside of the United States in a manner that would infringe the patent if such combination occurred within the United States. For example, Qualcomm supplies or causes to be supplied in or from the United States the hardware and/or

software/firmware components of the Accused Products that comprise all or a substantial portion of the components of the patented inventions of the '501 patent, where Qualcomm actively induces the combination of such components outside of the United States in a manner that would infringe the patent if such combination occurred within the United States. In another example, Qualcomm supplies or causes to be supplied in or from the United States the hardware and/or software/firmware components of the Accused Products that comprise all or a substantial portion of the components of the patented inventions of the '501 patent, where Qualcomm actively induces the combination of the hardware and/or software/firmware components with other components of an end user device outside of the United States in a manner that would infringe the patent if such combination occurred within the United States. Qualcomm intends to cause, and has taken affirmative steps to induce infringement by distributors, customers, subsidiaries, importers, partners, affiliates, resellers, manufacturers, and/or consumers by at least, inter alia, creating advertisements that promote the infringing use of the Accused Products, creating and/or maintaining and/or knowledge of established distribution channels for the Accused Products into and within the United States, manufacturing the components of the Accused Products in conformity with U.S. laws and regulations, manufacturing the components of the Accused Products in conformity with the relevant IEEE 802.11 standards, distributing or making available instructions or manuals or marketing materials regarding the combination of the hardware and software/firmware components, distributing or making available instructions or manuals or marketing materials regarding the combination of the hardware and/or software/firmware components with other components as part of making an end user device in part or in whole, testing and certifying features related to infringing features in the Accused Products, providing software and/or firmware for the Accused Products to manufacturers, purchasers, sellers, distributors,

and/or end users, and/or providing technical support, replacement parts, or services for these products to these purchasers and/or sellers in the United States.

161. On information and belief, since at least the above-mentioned dates when Qualcomm was on notice of its infringement, Qualcomm's infringement pursuant to 35 U.S.C. § 271(f)(2) includes supplying or causing to be supplied in or from the United States components of the patented invention of one or more claims of the '501 patent that are especially made or especially adapted for use in the invention and not staple articles or commodities of commerce suitable for substantial noninfringing use, where such components are uncombined in whole or in part, knowing that such components are so made or adapted and intending that such components will be combined outside of the United States in a manner that would infringe the patent if such combination occurred within the United States. For example, Qualcomm supplies or causes to be supplied in or from the United States the hardware and/or software/firmware components that comprise all or a substantial portion of the components of the patented inventions of the '501 patent, where such components are uncombined in whole or in part, knowing that such components are especially made or especially adapted for use in the invention and not staple articles or commodities of commerce suitable for substantial noninfringing use and intending that such components will be combined outside of the United States in a manner that would infringe the patent if such combination occurred within the United States. In another example, Qualcomm supplies or causes to be supplied in or from the United States the hardware and/or software/firmware components that comprise all or a substantial portion of the components of the patented inventions of the '501 patent, where such components are uncombined in whole or in part with other components of an end user device, knowing that such components are especially made or especially adapted for use in the invention and not staple articles or commodities of commerce

suitable for substantial noninfringing use and intending that such components will be combined with other components of an end user device outside of the United States in a manner that would infringe the patent if such combination occurred within the United States.

162. On information and belief, despite having knowledge of the '501 patent and knowledge that it is directly and/or indirectly infringing one or more claims of the '501 patent, Qualcomm has nevertheless continued its infringing conduct and disregarded an objectively high likelihood of infringement. Qualcomm's infringing activities relative to the '501 patent have been, and continue to be, willful, wanton, malicious, in bad-faith, deliberate, consciously wrongful, flagrant, characteristic of a pirate, and an egregious case of misconduct beyond typical infringement such that Plaintiff is entitled under 35 U.S.C. § 284 to enhanced damages up to three times the amount found or assessed.

163. Redwood has been damaged as a result of Qualcomm's infringing conduct described in this Count. Qualcomm is, thus, liable to Redwood in an amount that adequately compensates Redwood for Qualcomm's infringements, which, by law, cannot be less than a reasonable royalty, together with interest and costs as fixed by this Court under 35 U.S.C. § 284.

COUNT VII

(INFRINGEMENT OF U.S. PATENT NO. 9,374,209)

164. Plaintiff incorporates paragraphs 1 through 163 herein by reference.

165. Redwood is the assignee of the '209 patent, entitled "Transmission Signal Generation Apparatus, Transmission Signal Generation Method, Reception Signal Apparatus, and Reception Signal Method," with ownership of all substantial rights in the '209 patent, including the right to exclude others and to enforce, sue, and recover damages for past and future infringements.

166. The '209 patent is valid, enforceable, and was duly issued in full compliance with Title 35 of the United States Code. The '209 patent issued from U.S. Patent Application No. 14/703,938.

167. Qualcomm has and continues to directly and/or indirectly infringe one or more claims of the '209 patent in this judicial district and elsewhere in Texas and the United States.

168. Qualcomm directly infringes the '209 patent via 35 U.S.C. § 271(a) by making, using, offering for sale, selling, and/or importing the Accused Products, their components and processes, and/or products containing the same that incorporate the fundamental technologies covered by the '209 patent.

169. Furthermore, Defendants directly infringe the '209 patent through its direct involvement in the activities of its subsidiaries. Such subsidiaries conduct activities that constitute direct infringement of the '209 patent under 35 U.S.C. § 271(a) by making, using, offering for sale, selling, and/or importing those Accused Products, their components and processes, and/or products containing the same that incorporated the fundamental technologies covered by the '209 patent. Further, Defendants are vicariously liable for this infringing conduct of its subsidiaries (under both the alter ego and agency theories) because, as an example and on information and belief, Qualcomm Incorporated, QTI, and their subsidiaries and related companies are essentially the same company, and Qualcomm Incorporated and/or QTI have the right and ability to control their subsidiaries infringing acts and receive a direct financial benefit from the infringement of its subsidiaries. Furthermore, on information and belief, Qualcomm sells and makes the Accused Products outside of the United States, delivers those products to manufacturers, customers, distributors, and/or subsidiaries in the United States, or in the case that it delivers the Accused Products outside of the United States it does so intending and/or knowing that those products or

products that are manufactured to include Qualcomm's Accused Products are destined for the United States and/or designing those products for inclusion in other products to be placed on sale and used in the United States, thereby directly infringing the '209 patent. *See, e.g., Lake Cherokee Hard Drive Techs., L.L.C. v. Marvell Semiconductor, Inc.*, 964 F. Supp. 2d 653, 658 (E.D. Tex. 2013).

170. For example, Qualcomm infringes claim 1 of the '209 patent via the Accused Products, including the FastConnect 7800. The Accused Products, including the FastConnect 7800, comprise a transmission signal generation apparatus configured to generate transmission signals (*e.g.*, HT-mixed format transmission signals). *See, e.g.*, Figure 19-2 of IEEE 802.11 2016; <https://www.qualcomm.com/products/technology/wi-fi/fastconnect/fastconnect-7800> (“The Qualcomm FastConnect 7800 is an advanced 14nm Wi-Fi and Bluetooth® Connectivity system delivering ultra-high speeds;” “Standards: 802.11be, 802.11ax, 802.11ac, 802.11n, 802.11g, 802.11b, 802.11a;” “Antenna Configuration: 2x2;” and “Spatial Streams: Up to 4.”).

171. The Accused Products, including the FastConnect 7800, each comprise circuitry and/or components (hardware and/or software) configured to generate one or more transmission signals, where each transmission signal includes a data frame having preamble information, pilot information, and data information. *See, e.g.*, Sections 19.3.3 and 19.3.20 and Figure 19-2 of IEEE 802.11 2016. Further, each of the transmission signals include the PHY preamble, at least four pilot symbols, and data information. *See, e.g.*, Sections 19.3.1, 19.3.11.10, and 19.3.20 of IEEE 802.11 2016.

172. Each of the one or more transmission signals includes an associated preamble multiplied by a factor so that an average reception power of the associated preamble corresponds to an average reception power of the data information received with the associated preamble. For

example, each of the transmission signals is multiplied by a normalization factor corresponding to the modulation scheme to achieve the same average power for all mappings, where the preamble and data information can have different modulation types and therefore different corresponding normalization factors. *See, e.g.*, Section 17.3.5.8, Table 17-11, Equation 17-20, and Figure 17.1 of IEEE 802.11 2016.

173. Each of the one or more transmission signals includes plural pilot symbol sequences. For example, each of the transmission signals include at least four pilot symbols inserted in, for example, carrier positions -21, -7, 7, and 21. *See, e.g.*, Section 19.3.11.10 and Figure 19-3 of IEEE 802.11 2016.

174. The Accused Products, including the FastConnect 7800, each comprise circuitry and/or components (hardware and/or software) of an Inverse Fourier transformer configured to generate for each of the one or more transmission signals a corresponding OFDM signal for transmission by a corresponding one of one or more antennas by Inverse Fourier transforming each of the transmission signals. *See, e.g.*, Section 19.3.3 and Figure 19-3 of IEEE 802.11 2016.

175. The Inverse Fourier transformer of each of the Accused Products, including the FastConnect 7800, is configured to arrange the pilot symbol sequences in corresponding pilot carriers during a first time period. For example, the Inverse Fourier transformer is configured to arrange pilot sequences in the pilot carriers of each OFDM symbol transmitted during a first time period (*e.g.*, the 3.2 μ s DFT period). *See, e.g.*, Section 19.3.6, 19.3.11.10, 19.3.21, 19.4.3, and Equation 19-90 of IEEE 802.11 2016.

176. The transmitter of each of the Accused Products, including the FastConnect 7800, is configured to arrange sets of the pilot carriers in a same carrier position in the OFDM signal, where the plural pilot symbol sequences are all orthogonal to each other. For example, the

transmitter is configured to arrange pilot sequences for each space-time stream, where each of the OFDM signals contains four pilot carriers inserted in, for example, carrier positions -21, -7, 7, and 21. *See, e.g.*, Section 19.3.11.10, Equation 19-54, and Table 19-19 of IEEE 802.11 2016. Pilot sequences corresponding to different spatial streams are orthogonal to each other. *See, e.g.*, Table 19-19 of IEEE 802.11 2016.

177. The specific ways in which the Accused Products, including the FastConnect 7800, are configured to support the aforementioned features of IEEE 802.11n and/or IEEE 802.11ac and/or IEEE 802.11ax and/or IEEE 802.11be are further detailed in confidential documents and/or source code that evidence infringement by the Accused Products as to at least Claim 1 of the '209 patent.

178. Furthermore, the Accused Products, including the FastConnect 7800, are configured or implemented in an infringing manner with the features and functionality recited in at least Claim 1 of the '209 patent.

179. The technology discussion above and the exemplary Accused Products provide context for Plaintiff's infringement allegations.

180. The claims of the '209 patent are patent eligible under 35 U.S.C. § 101. The '209 patent is not directed to an ineligible abstract idea. For example, it is not a mathematical algorithm executed on a generic computer or a fundamental economic business practice. Instead, the '209 patent describes specific problems in signal transmission and communication involving multiple-input multiple-output (MIMO) OFDM communications and its claims are directed to specific ways of solving those problems. '209 patent, 2:39-64. In summary, "sufficient consideration has not been given to the method of transmitting symbols for transmission path estimation and symbols for frequency offset estimation to realize high accuracy frequency offset estimation, high accuracy

transmission path fluctuation estimation and high accuracy synchronization/signal detection” for MIMO-OFDM communications. *Id.* As the ’209 patent explains, “the present invention relates to a technology for realizing an ideal symbol configuration for ... MIMO-OFDM communication” to provide high accuracy frequency offset estimation, high accuracy transmission path estimation, and high accuracy signal detection. ’209 patent, 1:29-34. The ’209 patent claims specific technical solutions that achieve the aforementioned improvements. *See, e.g.*, ’209 patent, Claim 1.

181. Specifically, the ’209 patent describes that “orthogonal sequences are assigned to corresponding subcarriers among OFDM signals transmitted at the same time from the respective antennas in the time domain to form pilot carriers, so that, even when pilot symbols are multiplexed among a plurality of channels (antennas), it is possible to estimate frequency offset/phase noise with high accuracy. Furthermore, since pilot symbols of each channel can be extracted without using a channel estimator value (transmission path fluctuation estimation value), it is possible to simplify the configuration of the section for compensating for the frequency offset/phase noise.” ’209 patent, 3:9-19. These specific solutions are recited in claim 1 of the ’209 patent. This allows MIMO OFDM systems and devices to estimate frequency offset and/or phase noise with high accuracy even when pilot symbols are multiplexed on different channels. ’209 patent, 11:3-7. In the conventional solution, when the same carriers of channel A and channel B are not orthogonal to each other, the estimation accuracy for frequency offset and/or phase noise by frequency offset/phase noise estimation decreases (signals become components of interference with each other), and therefore it is not possible to realize high accuracy frequency offset/phase noise compensation. ’209 patent, 11:27-35. Furthermore, when a wireless LAN builds a system at the same frequency and in the same frequency band according to IEEE 802.11 and a spatial multiplexing MIMO system, this allows the frame configuration to be shared, and therefore it is

possible to simplify the reception apparatus. '209 patent, 9:4-14. "Another important advantage is that since no channel estimation value (transmission path fluctuation estimation value) is required, it is possible to simplify the configuration of the part for compensating for the frequency offset and/or phase noise." '209 patent, 11:7-11. If pilot symbols of channel A and channel B are not orthogonal to each other, signal processing of MIMO demultiplexing is carried out, such that frequency offset and/or phase noise are then estimated. '209 patent, 11:11-17. On the other hand, when the claimed solution is utilized, it is possible to compensate for frequency offset and/or phase noise before demultiplexing a signal. '209 patent, 11:17-21. In addition, the claimed solution allows for the frequency offset and/or phase noise to be removed using pilot symbols even after demultiplexing the signal of channel A from the signal of channel B, thereby making it possible to compensate for the frequency offset and/or phase noise with higher accuracy. '209 patent, 11:21-26.

182. Thus, the '209 patent describes problems to be solved in MIMO OFDM digital signal communications as well as specific solutions for solving those problems that are reflected in the claims, including claim 1.

183. The claims of the '209 patent also survive step two of Alice because they recite an inventive concept that provides features that are more than well-understood, routine, conventional activity.

184. At a minimum, Qualcomm has known of the '209 patent at least as early as the filing date of the Complaint. In addition, Qualcomm has known about the '209 patent since at least November 5, 2021, when Qualcomm and/or its agents received notice of the '209 patent via a letter. On November 5, 2021, Qualcomm received further notice of its infringement of the '209 patent when Redwood provided an infringement chart of the '209 patent via a data room that

Qualcomm downloaded on December 7, 2021 and again on January 19, 2022. Furthermore, Qualcomm has known about the '209 patent since at least May 12, 2022, when Qualcomm and/or its agents received notice of its infringement via email. On information and belief, Qualcomm has also had knowledge of the '209 patent based at least on its conduct before the USPTO. For example, at least one patent document related to the '209 patent was cited by the Examiner during the prosecution of the following patent documents assigned to Qualcomm: U.S. Patent No. 8,978,103 entitled "Method And Apparatus For Interworking Authorization Of Dual Stack Operation;" U.S. Patent No. 8,174,995 entitled "Method And Apparatus For Flexible Pilot Pattern;" and U.S. Patent No. 10,439,663 entitled "Method And Apparatus For Phase Noise Estimation In Data Symbols For Millimeter Wave Communications."

185. On information and belief, since at least the above-mentioned dates when Qualcomm was on notice of its infringement, Qualcomm has actively induced, under U.S.C. § 271(b), distributors, customers, subsidiaries, importers, partners, affiliates, resellers, manufacturers, end users, and/or consumers that make, import, use, purchase, offer to sell, and/or sell the Accused Products comprising all of the limitations of one or more claims of the '209 patent to directly infringe one or more claims of the '209 patent by making, using, offering for sale, selling, and/or importing the Accused Products. Since at least the notice provided on the above-mentioned dates, Qualcomm does so with knowledge, or with willful blindness of the fact, that the induced acts constitute infringement of the '209 patent. Qualcomm intends to cause, and has taken affirmative steps to induce infringement by distributors, customers, subsidiaries, importers, partners, affiliates, resellers, manufacturers, end users, and/or consumers by at least, inter alia, creating advertisements that promote the infringing use of the Accused Products, creating and/or maintaining and/or knowledge of established distribution channels for the Accused Products into

and within the United States, manufacturing the Accused Products in conformity with U.S. laws and regulations, manufacturing the Accused Products in conformity with the relevant IEEE 802.11 standards, distributing or making available instructions or manuals for the Accused Products to purchasers and prospective buyers, providing the accused functionalities via hardware, software, and/or firmware that are included in the Accused Products to manufacturers, purchasers, sellers, distributors, and/or end users, testing and certifying features related to infringing features in the Accused Products, and/or providing technical support, replacement parts, or services for these products to these purchasers and/or sellers in the United States.

186. On information and belief, since at least the above-mentioned dates when Qualcomm was on notice of its infringement, Qualcomm's contributory infringement pursuant to 35 U.S.C. § 271(c) includes offering to sell and/or license, selling and/or licensing, and/or providing within the United States, or importing into the United States, components of the patented invention of one or more claims of the '209 patent, constituting a material part of the invention. On information and belief, Qualcomm knows and has known the same to be especially made or especially adapted for use in an infringement of the '209 patent, and such components are not a staple article or commodity of commerce suitable for substantial noninfringing use. For example, Qualcomm offers to sell, sells, and/or licenses or otherwise provides hardware and/or software/firmware components of the Accused Products within the United States; the components constitute a material part of the claimed inventions of the '209 patent that are especially made or especially adapted for use in end user products that infringe the '209 patent; and the components are not a staple article or commodity of commerce suitable for substantial noninfringing use.

187. On information and belief, since at least the above-mentioned dates when Qualcomm was on notice of its infringement, Qualcomm's infringement pursuant to 35 U.S.C. §

271(f)(1) includes supplying or causing to be supplied in or from the United States all or a substantial portion of the components of the patented invention of one or more claims of the '209 patent, where such components are uncombined in whole or in part, in such manner as to actively induce the combination of such components outside of the United States in a manner that would infringe the patent if such combination occurred within the United States. For example, Qualcomm supplies or causes to be supplied in or from the United States the hardware and/or software/firmware components of the Accused Products that comprise all or a substantial portion of the components of the patented inventions of the '209 patent, where Qualcomm actively induces the combination of such components outside of the United States in a manner that would infringe the patent if such combination occurred within the United States. In another example, Qualcomm supplies or causes to be supplied in or from the United States the hardware and/or software/firmware components of the Accused Products that comprise all or a substantial portion of the components of the patented inventions of the '209 patent, where Qualcomm actively induces the combination of the hardware and/or software/firmware components with other components of an end user device outside of the United States in a manner that would infringe the patent if such combination occurred within the United States. Qualcomm intends to cause, and has taken affirmative steps to induce infringement by distributors, customers, subsidiaries, importers, partners, affiliates, resellers, manufacturers, and/or consumers by at least, inter alia, creating advertisements that promote the infringing use of the Accused Products, creating and/or maintaining and/or knowledge of established distribution channels for the Accused Products into and within the United States, manufacturing the components of the Accused Products in conformity with U.S. laws and regulations, manufacturing the components of the Accused Products in conformity with the relevant IEEE 802.11 standards, distributing or making available

instructions or manuals or marketing materials regarding the combination of the hardware and software/firmware components, distributing or making available instructions or manuals or marketing materials regarding the combination of the hardware and/or software/firmware components with other components as part of making an end user device in part or in whole, testing and certifying features related to infringing features in the Accused Products, providing software and/or firmware for the Accused Products to manufacturers, purchasers, sellers, distributors, and/or end users, and/or providing technical support, replacement parts, or services for these products to these purchasers and/or sellers in the United States.

188. On information and belief, since at least the above-mentioned dates when Qualcomm was on notice of its infringement, Qualcomm's infringement pursuant to 35 U.S.C. § 271(f)(2) includes supplying or causing to be supplied in or from the United States components of the patented invention of one or more claims of the '209 patent that are especially made or especially adapted for use in the invention and not staple articles or commodities of commerce suitable for substantial noninfringing use, where such components are uncombined in whole or in part, knowing that such components are so made or adapted and intending that such components will be combined outside of the United States in a manner that would infringe the patent if such combination occurred within the United States. For example, Qualcomm supplies or causes to be supplied in or from the United States the hardware and/or software/firmware components that comprise all or a substantial portion of the components of the patented inventions of the '209 patent, where such components are uncombined in whole or in part, knowing that such components are especially made or especially adapted for use in the invention and not staple articles or commodities of commerce suitable for substantial noninfringing use and intending that such components will be combined outside of the United States in a manner that would infringe the

patent if such combination occurred within the United States. In another example, Qualcomm supplies or causes to be supplied in or from the United States the hardware and/or software/firmware components that comprise all or a substantial portion of the components of the patented inventions of the '209 patent, where such components are uncombined in whole or in part with other components of an end user device, knowing that such components are especially made or especially adapted for use in the invention and not staple articles or commodities of commerce suitable for substantial noninfringing use and intending that such components will be combined with other components of an end user device outside of the United States in a manner that would infringe the patent if such combination occurred within the United States.

189. On information and belief, despite having knowledge of the '209 patent and knowledge that it is directly and/or indirectly infringing one or more claims of the '209 patent, Qualcomm has nevertheless continued its infringing conduct and disregarded an objectively high likelihood of infringement. Qualcomm's infringing activities relative to the '209 patent have been, and continue to be, willful, wanton, malicious, in bad-faith, deliberate, consciously wrongful, flagrant, characteristic of a pirate, and an egregious case of misconduct beyond typical infringement such that Plaintiff is entitled under 35 U.S.C. § 284 to enhanced damages up to three times the amount found or assessed.

190. Redwood has been damaged as a result of Qualcomm's infringing conduct described in this Count. Qualcomm is, thus, liable to Redwood in an amount that adequately compensates Redwood for Qualcomm's infringements, which, by law, cannot be less than a reasonable royalty, together with interest and costs as fixed by this Court under 35 U.S.C. § 284.

COUNT VIII

(INFRINGEMENT OF U.S. PATENT NO. 10,270,574)

191. Plaintiff incorporates paragraphs 1 through 190 herein by reference.

192. Redwood is the assignee of the '574 patent, entitled "Transmission Signal Generation Apparatus, Transmission Signal Generation Method, Reception Signal Apparatus, and Reception Signal Method," with ownership of all substantial rights in the '574 patent, including the right to exclude others and to enforce, sue, and recover damages for past and future infringements.

193. The '574 patent is valid, enforceable, and was duly issued in full compliance with Title 35 of the United States Code. The '574 patent issued from U.S. Patent Application No. 16/059,093.

194. Qualcomm has and continues to directly and/or indirectly infringe one or more claims of the '574 patent in this judicial district and elsewhere in Texas and the United States.

195. Qualcomm directly infringes the '574 patent via 35 U.S.C. § 271(a) by making, using, offering for sale, selling, and/or importing the Accused Products, their components and processes, and/or products containing the same that incorporate the fundamental technologies covered by the '574 patent.

196. Furthermore, Defendants directly infringe the '574 patent through its direct involvement in the activities of its subsidiaries. Such subsidiaries conduct activities that constitute direct infringement of the '574 patent under 35 U.S.C. § 271(a) by making, using, offering for sale, selling, and/or importing those Accused Products, their components and processes, and/or products containing the same that incorporated the fundamental technologies covered by the '574 patent. Further, Defendants are vicariously liable for this infringing conduct of its subsidiaries (under both the alter ego and agency theories) because, as an example and on information and belief, Qualcomm Incorporated, QTI, and their subsidiaries and related companies are essentially the same company, and Qualcomm Incorporated and/or QTI have the right and ability to control their

subsidiaries infringing acts and receive a direct financial benefit from the infringement of its subsidiaries. Furthermore, on information and belief, Qualcomm sells and makes the Accused Products outside of the United States, delivers those products to manufacturers, customers, distributors, and/or subsidiaries in the United States, or in the case that it delivers the Accused Products outside of the United States it does so intending and/or knowing that those products or products that are manufactured to include Qualcomm's Accused Products are destined for the United States and/or designing those products for inclusion in other products to be placed on sale and used in the United States, thereby directly infringing the '574 patent. *See, e.g., Lake Cherokee Hard Drive Techs., L.L.C. v. Marvell Semiconductor, Inc.*, 964 F. Supp. 2d 653, 658 (E.D. Tex. 2013).

197. For example, Qualcomm infringes claim 1 of the '574 patent via the Accused Products, including the FastConnect 7800. The Accused Products, including the FastConnect 7800, are compliant with IEEE 802.11n and/or IEEE 802.11ac and/or IEEE 802.11ax and/or IEEE 802.11be and comprise a transmission apparatus that includes electronic circuitry compliant with the aforementioned IEEE standards. *See, e.g.,* Sections 17.3.8.2, 19.1.1, 19.3.3 and Figure 19-3 of IEEE 802.11 2016; <https://www.qualcomm.com/products/technology/wi-fi/fastconnect/fastconnect-7800> (“The Qualcomm FastConnect 7800 is an advanced 14nm Wi-Fi and Bluetooth® Connectivity system delivering ultra-high speeds;” “Standards: 802.11be, 802.11ax, 802.11ac, 802.11n, 802.11g, 802.11b, 802.11a;” “Antenna Configuration: 2x2;” and “Spatial Streams: Up to 4.”).

198. The Accused Products, including the FastConnect 7800, comprise electronic circuitry configured to map a first stream of input data to first complex symbols in serial format.

For example, the Accused Products comprise a constellation mapper to map a sequence of bits to a series of complex numbers. *See, e.g.*, Section 17.3.2.2 of IEEE 802.11 2016.

199. The Accused Products, including the FastConnect 7800, comprise electronic circuitry configured to convert the first complex symbols in serial format into first complex symbols in parallel format. For example, the Accused Products are configured to insert the complex numbers into subcarriers associated with one OFDM symbol, such that the information in each subcarrier is transmitted in parallel as part of the full OFDM symbol. *See, e.g.*, Section 17.3.2.2 of IEEE 802.11 2016. For example, a complex value $-0.316 + 0.316j$ is inserted in subcarrier 26 to form OFDM symbols in the frequency domain. *See, e.g.*, Section I.1.6.3 and Table I-20 of IEEE 802.11 2016.

200. The Accused Products, including the FastConnect 7800, comprise electronic circuitry configured to perform an inverse Fourier transform on the first complex symbols in parallel format to form first Orthogonal Frequency Division Multiplexed (OFDM) signals associated with multiple subcarriers. For example, the Accused Products comprise inverse discrete fourier transform sections configured to convert the plurality of symbols to OFDM time domain blocks for transmission. *See, e.g.*, Section 17.3.2.2 of IEEE 802.11 2016.

201. The Accused Products, including the FastConnect 7800, comprise electronic circuitry configured to transmit the first OFDM signals over the multiple subcarriers in a same frequency band over a same time period that includes a same set of time slots. For example, the Accused Products are configured to transmit signals comprising OFDM symbols from each antenna, where each OFDM symbol is a time slot and transmissions occur within a same time period indicated by the TXTIME parameter over a channel having the same frequency band (e.g.,

20 MHz). *See, e.g.*, Sections 17.3.2.2, 19.3.15.1, 19.3.221, Figure 17.1, and Equation 19-90 of IEEE 802.11 2016.

202. The Accused Products, including the FastConnect 7800, comprise electronic circuitry configured to transmit first pilot information on a first one of a plurality of pilot subcarriers during the same set of time slots. For example, the Accused Products are configured to transmit a first pilot value of 1 placed on a first pilot subcarrier within an OFDM symbol during the same set of time slots. *See, e.g.*, Sections 17.3.5.9 and Table 19-19 of IEEE 802.11 2016.

203. The Accused Products, including the FastConnect 7800, comprise electronic circuitry configured to transmit second pilot information on a second one of a plurality of pilot subcarriers during the same set of time slots, the second pilot information being different from the first pilot information. For example, the Accused Products are configured to transmit a second pilot value of -1 placed on a second pilot subcarrier within an OFDM symbol that will be transmitted during the same set of time slots. *See, e.g.*, Sections 17.3.5.9 and Table 19-19 of IEEE 802.11 2016.

204. The Accused Products, including the FastConnect 7800, comprise electronic circuitry configured to map a second stream of input data to second complex symbols in serial format. For example, the Accused Products comprise a constellation mapper to map a sequence of bits to a series of constellation points. *See, e.g.*, Section 17.3.2.2 of IEEE 802.11 2016.

205. The Accused Products, including the FastConnect 7800, comprise electronic circuitry configured to convert the second complex symbols in serial format into second complex symbols in parallel format. For example, the Accused Products are configured to insert the complex numbers into subcarriers associated with one OFDM symbol, such that the information in each subcarrier is transmitted in parallel as part of the full OFDM symbol. *See, e.g.*, Section

17.3.2.2 of IEEE 802.11 2016. For example, a complex value $-0.316 + 0.316j$ is inserted in subcarrier 26 to form OFDM symbols in the frequency domain. *See, e.g.*, Section I.1.6.3 and Table I-20 of IEEE 802.11 2016.

206. The Accused Products, including the FastConnect 7800, comprise electronic circuitry configured to perform an inverse Fourier transform on the second complex symbols in parallel format to form second OFDM signals associated with the multiple subcarriers. For example, the Accused Products comprise inverse discrete fourier transform sections configured to convert the plurality of symbols to OFDM time domain blocks for transmission. *See, e.g.*, Section 17.3.2.2 of IEEE 802.11 2016.

207. The Accused Products, including the FastConnect 7800, comprise electronic circuitry configured to transmit the second OFDM signals over the multiple subcarriers in the same frequency band over the same time period that includes the same set of time slots. For example, the Accused Products are configured to transmit signals comprising OFDM symbols from each antenna, where each OFDM symbol is a time slot and transmissions occur within a same time period indicated by the TXTIME parameter over a channel having the same frequency band (e.g., 20 MHz). *See, e.g.*, Sections 17.3.2.2, 19.3.15.1, 19.3.221, Figure 17.1, and Equation 19-90 of IEEE 802.11 2016.

208. The Accused Products, including the FastConnect 7800, comprise electronic circuitry configured to transmit the first pilot information on the second pilot subcarrier during the same set of time slots. For example, the Accused Products are configured to transmit a first pilot value of 1 placed on a second pilot subcarrier within an OFDM symbol during the same set of time slots. *See, e.g.*, Sections 17.3.5.9 and Table 19-19 of IEEE 802.11 2016.

209. The Accused Products, including the FastConnect 7800, comprise electronic circuitry configured to transmit the second pilot information on one of the plurality of pilot subcarriers during the same set of time slots. For example, the Accused Products are configured to transmit a second pilot value of -1 placed on a pilot subcarrier within an OFDM symbol that will be transmitted during the same set of time slots. *See, e.g.*, Sections 17.3.5.9 and Table 19-19 of IEEE 802.11 2016.

210. The specific ways in which the Accused Products, including the FastConnect 7800, are configured to support the aforementioned features of IEEE 802.11n and/or IEEE 802.11ac and/or IEEE 802.11ax and/or IEEE 802.11be are further detailed in confidential documents and/or source code that evidence infringement by the Accused Products as to at least Claim 1 of the '574 patent.

211. Furthermore, the Accused Products, including the FastConnect 7800, are configured or implemented in an infringing manner with the features and functionality recited in at least Claim 1 of the '574 patent.

212. The technology discussion above and the exemplary Accused Products provide context for Plaintiff's infringement allegations.

213. The claims of the '574 patent are patent eligible under 35 U.S.C. § 101. The '574 patent is not directed to an ineligible abstract idea. For example, it is not a mathematical algorithm executed on a generic computer or a fundamental economic business practice. Instead, the '574 patent describes specific problems in signal transmission and communication involving multiple-input multiple-output (MIMO) OFDM communications and its claims are directed to specific ways of solving those problems. '574 patent, 2:50-3:9. In summary, "sufficient consideration has not been given to the method of transmitting symbols for transmission path estimation and symbols

for frequency offset estimation to realize high accuracy frequency offset estimation, high accuracy transmission path fluctuation estimation and high accuracy synchronization/signal detection” for MIMO-OFDM communications. *Id.* As the ’574 patent explains, “the present invention relates to a technology for realizing an ideal symbol configuration for ... MIMO-OFDM communication” to provide high accuracy frequency offset estimation, high accuracy transmission path estimation, and high accuracy signal detection. ’574 patent, 1:39-44. The ’574 patent claims specific technical solutions that achieve the aforementioned improvements. *See, e.g.,* ’574 patent, Claims 1-2.

214. Specifically, the ’574 patent describes that “orthogonal sequences are assigned to corresponding subcarriers among OFDM signals transmitted at the same time from the respective antennas in the time domain to form pilot carriers, so that, even when pilot symbols are multiplexed among a plurality of channels (antennas), it is possible to estimate frequency offset/phase noise with high accuracy. Furthermore, since pilot symbols of each channel can be extracted without using a channel estimator value (transmission path fluctuation estimation value), it is possible to simplify the configuration of the section for compensating for the frequency offset/phase noise.” ’574 patent, 3:21-32. These specific solutions are recited in claims 1-2 of the ’574 patent. This allows MIMO OFDM systems and devices to estimate frequency offset and/or phase noise with high accuracy even when pilot symbols are multiplexed on different channels. ’574 patent, 11:27-31. In the conventional solution, when the same carriers of channel A and channel B are not orthogonal to each other, the estimation accuracy for frequency offset and/or phase noise by frequency offset/phase noise estimation decreases (signals become components of interference with each other), and therefore it is not possible to realize high accuracy frequency offset/phase noise compensation. ’574 patent, 11:52-61. Furthermore, when a wireless LAN builds a system at the same frequency and in the same frequency band according to IEEE 802.11 and a spatial

multiplexing MIMO system, this allows the frame configuration to be shared, and therefore it is possible to simplify the reception apparatus. '574 patent, 9:24-24. "Another important advantage is that since no channel estimation value (transmission path fluctuation estimation value) is required, it is possible to simplify the configuration of the part for compensating for the frequency offset and/or phase noise." '574 patent, 11:32-36. If pilot symbols of channel A and channel B are not orthogonal to each other, signal processing of MIMO demultiplexing is carried out, such that frequency offset and/or phase noise are then estimated. '574 patent, 11:36-42. On the other hand, when the claimed solutions are utilized, it is possible to compensate for frequency offset and/or phase noise before demultiplexing a signal. '574 patent, 11:42-45. In addition, the claimed solutions allow for the frequency offset and/or phase noise to be removed using pilot symbols even after demultiplexing the signal of channel A from the signal of channel B, thereby making it possible to compensate for the frequency offset and/or phase noise with higher accuracy. '574 patent, 11:46-51.

215. Furthermore, the '574 patent discloses additional improvements to symbol configurations for MIMO OFDM communications. Claim 1 of the '574 patent recites that "the second pilot information being different from the first pilot information" as to the OFDM transmissions from each of the first and second antennas during the same time period that includes the same set of time slots in the same frequency band. According to this improved configuration, when MIMO OFDM transmissions are carried out using more than one antenna, it minimizes an increase of transmission peak without degrading estimation accuracy for frequency offset/phase noise. '574 patent, 3:43-47, 10:34-40.

216. Thus, the '574 patent describes problems to be solved in MIMO OFDM digital signal communications as well as specific solutions for solving those problems that are reflected in the claims, including claims 1 and 2.

217. The claims also survive step two of Alice because they recite an inventive concept that provides features that are more than well-understood, routine, conventional activity.

218. At a minimum, Qualcomm has known of the '574 patent at least as early as the filing date of the Complaint. In addition, Qualcomm has known about the '574 patent since at least November 5, 2021, when Qualcomm and/or its agents received notice of the '574 patent via a letter. On November 22, 2021, Qualcomm received further notice of its infringement of the '574 patent when Redwood provided an infringement chart of the '574 patent via a data room that Qualcomm downloaded on December 7, 2021 and again on January 19, 2022. Furthermore, Qualcomm has known about the '574 patent since at least May 12, 2022, when Qualcomm and/or its agents received notice of its infringement via email. On information and belief, Qualcomm has also had knowledge of the '574 patent based at least on its conduct before the USPTO. For example, at least one patent document related to the '574 patent was cited by the Examiner during the prosecution of the following patent documents assigned to Qualcomm: U.S. Patent No. 8,978,103 entitled "Method And Apparatus For Interworking Authorization Of Dual Stack Operation;" U.S. Patent No. 8,174,995 entitled "Method And Apparatus For Flexible Pilot Pattern;" and U.S. Patent No. 10,439,663 entitled "Method And Apparatus For Phase Noise Estimation In Data Symbols For Millimeter Wave Communications."

219. On information and belief, since at least the above-mentioned dates when Qualcomm was on notice of its infringement, Qualcomm has actively induced, under U.S.C. § 271(b), distributors, customers, subsidiaries, importers, partners, affiliates, resellers,

manufacturers, end users, and/or consumers that make, import, use, purchase, offer to sell, and/or sell the Accused Products comprising all of the limitations of one or more claims of the '574 patent to directly infringe one or more claims of the '574 patent by making, using, offering for sale, selling, and/or importing the Accused Products. Since at least the notice provided on the above-mentioned dates, Qualcomm does so with knowledge, or with willful blindness of the fact, that the induced acts constitute infringement of the '574 patent. Qualcomm intends to cause, and has taken affirmative steps to induce infringement by distributors, customers, subsidiaries, importers, partners, affiliates, resellers, manufacturers, end users, and/or consumers by at least, inter alia, creating advertisements that promote the infringing use of the Accused Products, creating and/or maintaining and/or knowledge of established distribution channels for the Accused Products into and within the United States, manufacturing the Accused Products in conformity with U.S. laws and regulations, manufacturing the Accused Products in conformity with the relevant IEEE 802.11 standards, distributing or making available instructions or manuals for the Accused Products to purchasers and prospective buyers, providing the accused functionalities via hardware, software, and/or firmware that are included in the Accused Products to manufacturers, purchasers, sellers, distributors, and/or end users, testing and certifying features related to infringing features in the Accused Products, and/or providing technical support, replacement parts, or services for these products to these purchasers and/or sellers in the United States.

220. On information and belief, since at least the above-mentioned dates when Qualcomm was on notice of its infringement, Qualcomm's contributory infringement pursuant to 35 U.S.C. § 271(c) includes offering to sell and/or license, selling and/or licensing, and/or providing within the United States, or importing into the United States, components of the patented invention of one or more claims of the '574 patent, constituting a material part of the invention.

On information and belief, Qualcomm knows and has known the same to be especially made or especially adapted for use in an infringement of the '574 patent, and such components are not a staple article or commodity of commerce suitable for substantial noninfringing use. For example, Qualcomm offers to sell, sells, and/or licenses or otherwise provides hardware and/or software/firmware components of the Accused Products within the United States; the components constitute a material part of the claimed inventions of the '574 patent that are especially made or especially adapted for use in end user products that infringe the '574 patent; and the components are not a staple article or commodity of commerce suitable for substantial noninfringing use.

221. On information and belief, since at least the above-mentioned dates when Qualcomm was on notice of its infringement, Qualcomm's infringement pursuant to 35 U.S.C. § 271(f)(1) includes supplying or causing to be supplied in or from the United States all or a substantial portion of the components of the patented invention of one or more claims of the '574 patent, where such components are uncombined in whole or in part, in such manner as to actively induce the combination of such components outside of the United States in a manner that would infringe the patent if such combination occurred within the United States. For example, Qualcomm supplies or causes to be supplied in or from the United States the hardware and/or software/firmware components of the Accused Products that comprise all or a substantial portion of the components of the patented inventions of the '574 patent, where Qualcomm actively induces the combination of such components outside of the United States in a manner that would infringe the patent if such combination occurred within the United States. In another example, Qualcomm supplies or causes to be supplied in or from the United States the hardware and/or software/firmware components of the Accused Products that comprise all or a substantial portion of the components of the patented inventions of the '574 patent, where Qualcomm actively induces

the combination of the hardware and/or software/firmware components with other components of an end user device outside of the United States in a manner that would infringe the patent if such combination occurred within the United States. Qualcomm intends to cause, and has taken affirmative steps to induce infringement by distributors, customers, subsidiaries, importers, partners, affiliates, resellers, manufacturers, and/or consumers by at least, inter alia, creating advertisements that promote the infringing use of the Accused Products, creating and/or maintaining and/or knowledge of established distribution channels for the Accused Products into and within the United States, manufacturing the components of the Accused Products in conformity with U.S. laws and regulations, manufacturing the components of the Accused Products in conformity with the relevant IEEE 802.11 standards, distributing or making available instructions or manuals or marketing materials regarding the combination of the hardware and software/firmware components, distributing or making available instructions or manuals or marketing materials regarding the combination of the hardware and/or software/firmware components with other components as part of making an end user device in part or in whole, testing and certifying features related to infringing features in the Accused Products, providing software and/or firmware for the Accused Products to manufacturers, purchasers, sellers, distributors, and/or end users, and/or providing technical support, replacement parts, or services for these products to these purchasers and/or sellers in the United States.

222. On information and belief, since at least the above-mentioned dates when Qualcomm was on notice of its infringement, Qualcomm's infringement pursuant to 35 U.S.C. § 271(f)(2) includes supplying or causing to be supplied in or from the United States components of the patented invention of one or more claims of the '574 patent that are especially made or especially adapted for use in the invention and not staple articles or commodities of commerce

suitable for substantial noninfringing use, where such components are uncombined in whole or in part, knowing that such components are so made or adapted and intending that such components will be combined outside of the United States in a manner that would infringe the patent if such combination occurred within the United States. For example, Qualcomm supplies or causes to be supplied in or from the United States the hardware and/or software/firmware components that comprise all or a substantial portion of the components of the patented inventions of the '574 patent, where such components are uncombined in whole or in part, knowing that such components are especially made or especially adapted for use in the invention and not staple articles or commodities of commerce suitable for substantial noninfringing use and intending that such components will be combined outside of the United States in a manner that would infringe the patent if such combination occurred within the United States. In another example, Qualcomm supplies or causes to be supplied in or from the United States the hardware and/or software/firmware components that comprise all or a substantial portion of the components of the patented inventions of the '574 patent, where such components are uncombined in whole or in part with other components of an end user device, knowing that such components are especially made or especially adapted for use in the invention and not staple articles or commodities of commerce suitable for substantial noninfringing use and intending that such components will be combined with other components of an end user device outside of the United States in a manner that would infringe the patent if such combination occurred within the United States.

223. On information and belief, despite having knowledge of the '574 patent and knowledge that it is directly and/or indirectly infringing one or more claims of the '574 patent, Qualcomm has nevertheless continued its infringing conduct and disregarded an objectively high likelihood of infringement. Qualcomm's infringing activities relative to the '574 patent have been,

and continue to be, willful, wanton, malicious, in bad-faith, deliberate, consciously wrongful, flagrant, characteristic of a pirate, and an egregious case of misconduct beyond typical infringement such that Plaintiff is entitled under 35 U.S.C. § 284 to enhanced damages up to three times the amount found or assessed.

224. Redwood has been damaged as a result of Qualcomm's infringing conduct described in this Count. Qualcomm is, thus, liable to Redwood in an amount that adequately compensates Redwood for Qualcomm's infringements, which, by law, cannot be less than a reasonable royalty, together with interest and costs as fixed by this Court under 35 U.S.C. § 284.

CONCLUSION

225. Plaintiff Redwood is entitled to recover from Qualcomm the damages sustained by Plaintiff as a result of Qualcomm's wrongful acts, and willful infringement, in an amount subject to proof at trial, which, by law, cannot be less than a reasonable royalty, together with interest and costs as fixed by this Court.

226. Plaintiff has incurred and will incur attorneys' fees, costs, and expenses in the prosecution of this action. The circumstances of this dispute may give rise to an exceptional case within the meaning of 35 U.S.C. § 285, and Plaintiff is entitled to recover its reasonable and necessary attorneys' fees, costs, and expenses.

JURY DEMAND

227. Plaintiff hereby requests a trial by jury pursuant to Rule 38 of the Federal Rules of Civil Procedure.

PRAYER FOR RELIEF

228. Plaintiff respectfully requests that the Court find in its favor and against Qualcomm, and that the Court grant Plaintiff the following relief:

1. A judgment that Qualcomm has infringed the Asserted Patents as alleged herein, directly and/or indirectly;
2. A judgment for an accounting of all damages sustained by Plaintiff as a result of the acts of infringement by Qualcomm;
3. A judgment and order requiring Qualcomm to pay Plaintiff damages under 35 U.S.C. § 284, including up to treble damages as provided by 35 U.S.C. § 284, and any royalties determined to be appropriate;
4. A judgment and order requiring Qualcomm to pay Plaintiff pre-judgment and post-judgment interest on the damages awarded;
5. A judgment and order finding this to be an exceptional case and requiring Qualcomm to pay the costs of this action (including all disbursements) and attorneys' fees as provided by 35 U.S.C. § 285; and
6. Such other and further relief as the Court deems just and equitable.

Dated: October 4, 2023

Respectfully submitted,

/s/ Patrick J. Conroy

Patrick J. Conroy

Texas Bar No. 24012448

T. William Kennedy Jr.

Texas Bar No. 24055771

Jon Rastegar

Texas Bar No. 24064043

Nelson Bumgardner Conroy PC

2727 N. Harwood St.

Suite 250

Dallas, TX 75201

Tel: (214) 446-4950

pat@nelbum.com

bill@nelbum.com

jon@nelbum.com

John P. Murphy

Texas Bar No. 24056024
Nelson Bumgardner Conroy PC
3131 W 7th St
Suite 300
Fort Worth, TX 76107
Tel: (817) 377-9111
murphy@nelbum.com

Attorneys for Plaintiff
Redwood Technologies, LLC