

**IN THE UNITED STATES DISTRICT COURT
FOR THE EASTERN DISTRICT OF TEXAS
MARSHALL DIVISION**

PROCOMM INTERNATIONAL PTE. LTD.,

Plaintiff,

v.

VERIZON COMMUNICATIONS, INC.,
CELLCO PARTNERSHIP D/B/A VERIZON
WIRELESS, TELEFONAKTIEBOLAGET LM
ERICSSON, and ERICSSON INC.,

Defendants.

Civil Action No. 2:24-cv-00009

JURY TRIAL DEMANDED

COMPLAINT FOR PATENT INFRINGEMENT

Plaintiff Procomm International Pte. Ltd. (“Procomm”) hereby files this complaint for patent infringement pursuant to 35 U.S.C. §§ 100 *et seq.* against Defendants Verizon Communications, Inc. and Cellco Partnership d/b/a Verizon Wireless (collectively, “Verizon,” or “the Verizon Defendants”), Telefonaktiebolaget LM Ericsson (“LM Ericsson”), and Ericsson, Inc. (“Ericsson USA”) (collectively, LM Ericsson and Ericsson USA are “Ericsson” or “the Ericsson Defendants,” and the Ericsson Defendants together with the Verizon Defendants are “the Defendants”) for infringement of U.S. Patent Nos. 8,583,100 (“the ’100 Patent”), 7,103,377 (“the ’377 Patent”), 7,834,721 (“the ’721 patent”), 8,497,813 (“the ’813 Patent”), and 7,724,521 (“the ’521 Patent,” and collectively with the ’100, ’377, ’721, and ’813 Patents, “the Asserted Patents”) and alleges as follows:

I. THE PARTIES

1. Procomm is a corporation organized under the laws of Singapore, having a place of business at 160 Robinson Road, #24-09, SBF Center, Singapore, 068914.

2. Procomm is the sole and exclusive rightful owner of the Asserted Patents and holds, *inter alia*, the sole and exclusive right to sue and collect damages for past and current infringement.

3. Upon information and belief, Defendant Verizon Communications, Inc. is a corporation organized and existing under the laws of Delaware with a principal place of business at 1095 Avenue of the Americas, New York, New York 10036. Verizon Communications, Inc. may be served through its registered agent, Corporation Trust Company, Corporation Trust Center, at 1209 Orange Street, Wilmington, Delaware, 19801. Upon information and belief, Verizon Communications, Inc. does business in Texas, directly or through intermediaries, and offers its products and/or services, including those accused herein of infringement, to customers and potential customers located in Texas, including in this District.

4. Upon information and belief, Defendant Cellco Partnership D/B/A Verizon Wireless (“Verizon Wireless”) is a general partnership organized and existing under the laws of Delaware, with a principal place of business at 1 Verizon Way, Basking Ridge, NJ 07920. Verizon Wireless can be served through its registered agent, Corporation Trust Company, Corporation Trust Center, at 1209 Orange Street, Wilmington, Delaware 19801. Upon information and belief, Verizon Wireless does business in Texas, directly or through intermediaries, and offers its products and/or services, including those accused herein of infringement, to customers and potential customers located in Texas, including in this District.

5. Verizon operates some of the largest wireless networks in the United States, providing voice and data services nationwide, including in this District.

6. Upon information and belief, Verizon Wireless is an indirect, wholly-owned subsidiary of Verizon Communications, and the Verizon Defendants have acted in concert with

respect to the facts alleged herein such that any act of either Verizon Defendant is attributable to both Verizon Defendants.

7. Defendant LM Ericsson is a corporation organized and existing under the laws of Sweden with its principal place of business at Torshamnsgatan 21, Kista, Stockholm, 164 83, Sweden. Upon information and belief, LM Ericsson does business in Texas, directly or through intermediaries, and offers its products and/or services, including those accused herein of infringement, to customers and potential customers located in Texas, including in this District.

8. Defendant Ericsson USA is a corporation organized and existing under the laws of Delaware with its principal place of business at 6300 Legacy Drive, Plano, Texas 750254. Ericsson USA is registered to do business in the State of Texas. Upon information and belief, Ericsson USA manufactures and distributes infringing products throughout the United States, including in this District. Ericsson USA may be served through its registered agent Capitol Services, Inc., 108 Lakeland Avenue, Dover, Delaware 19901.

9. Upon information and belief, Ericsson USA is wholly-owned and controlled by LM Ericsson, and the Ericsson Defendants have acted in concert with respect to the facts alleged herein such that any act of either Ericsson Defendant is attributable to both Ericsson Defendants.

10. As pled below, Defendants have worked together and collectively to infringe the Asserted Patents, including through committing acts of infringement at regular and established places of business within this District.

II. JURISDICTION AND VENUE

11. This is an action for patent infringement arising under the Patent Laws of the United States, 35 U.S.C. §§ 271 and 281, *et seq.*

12. Subject matter jurisdiction is proper pursuant to 28 U.S.C. §§ 1331 and 1338.

13. This Court has personal jurisdiction over the Verizon Defendants, both of which, upon information and belief, have committed acts of infringement in this District in violation of 35 U.S.C. § 271. In particular, they have performed infringing methods, and have made, used, and provided infringing products, systems, and services in connection with providing Verizon's 5G network. The Verizon Defendants derive substantial revenue from the sale and use of infringing products and services in this District and should reasonably expect their actions to have consequences within this District.

14. Verizon maintains a significant physical presence in this District. Verizon is registered to do business in Texas and has regular and established places of business in this District, including at least those at: 1901 10th St, Plano, Texas 75074; 1111 E Grand Avenue, Marshall, Texas 75670; and 500 East Loop 281, Longview, Texas 75605, among many others. There are numerous Verizon retail stores within this District, including those in Plano, Marshall, and Longview, Texas. The purpose of these stores is to sell user devices (*e.g.*, cell phones) and telecommunications services to be provided by the Verizon Defendants.

15. Verizon operates and sells access to a 5G wireless network that provides telecommunications services to customers via cellular base stations located throughout the United States, including in this District. Verizon's network coverage extends to cities in this District, including within the Marshall division, according to Verizon's website.

16. In other recent actions, Verizon has submitted to venue in this District for patent infringement actions against it. *See, e.g.*, Agreed Joint Motion to Transfer Severed Action to the Eastern District of Texas, *Dali Wireless, Inc. v. Cellco Partnership d/b/a Verizon Wireless*, 6:22-cv-00104-ADA (W.D. Texas) (D.I. 20); Defendant's Answer to First Amended Complaint For Patent Infringement, *Finesse Wireless LLC v. Cellco Partnership d/b/a Verizon Wireless*, 2-21-

cv-00317 (E.D. Tex.) (D.I. 18); Verizon's Answer and Counterclaims, *Cobblestone Wireless, LLC v. T-Mobile USA, Inc., T-Mobile US Inc.*, 2:22-cv-00477-JRG-RSP (D.I. 20).

17. This Court has personal jurisdiction over the Ericsson Defendants, both of which, upon information and belief, have committed acts of infringement in this judicial district in violation of 35 U.S.C. § 271. In particular, they have performed infringing methods and have made and distributed infringing products for providing 5G wireless telecommunications services. The Ericsson Defendants derive substantial revenue from the sale of infringing services and products distributed within this District and expect or should reasonably expect their actions to have consequences within this District.

18. Ericsson maintains a significant physical presence in this District. Ericsson's U.S. headquarters are located within this District at 6300 Legacy Drive, Plano, Texas 75024. Upon information and belief, Ericsson USA is wholly-owned and controlled by LM Ericsson and acts as the agent for LM Ericsson in making sales, servicing equipment, and carrying out operations of LM Ericsson in North America. Upon information and belief, representatives of LM Ericsson regularly visit this District in their supervisory capacity over Ericsson USA. Ericsson manufactures, imports, and distributes infringing wireless telecommunications equipment in the United States for installation into Verizon's network, including in this District. *See* https://www.sec.gov/Archives/edgar/data/0000717826/000119312521094445/d52839d20f.htm#toc52839_9 (discussing LM Ericsson's investment into its Lewisville, Texas smart factory that produces "millimeter-wave Street Macro base stations, which is key to Ericsson's 5G portfolio for its North American customers"); <https://www.ericsson.com/en/blog/2021/1/smart-factory-of-the-future> (stating Ericsson's Lewisville, Texas smart factory produces devices "that enable large-scale deployments in 4G and 5G mobile networks").

19. In addition, Ericsson's website advertises that Ericsson USA maintains established places of business in this District, including (1) its U.S. headquarters at 6300 Legacy Drive, Plano, TX 75024; (2) a 5G Smart Factory in Lewisville, TX; and (3) a training center in Lewisville, TX. *See* <https://www.ericsson.com/en/about-us/company-facts/ericsson-worldwide/united-states>; <https://www.ericsson.com/en/about-us/company-facts/ericsson-worldwide/united-states/5g-smart-factory>; <https://www.ericsson.com/en/industries/energy-utilities/ericsson-utilities-innovation-center>; <https://www.ericsson.com/en/about-us/company-facts/ericsson-worldwide/united-states/ericssons-training-center-of-excellence>.

20. Ericsson has deployed its 5G end-to-end distributed network in the State of Texas and this District. For example, Ericsson created a multi-campus 5G network spanning its Plano and Richardson facilities. *See* <https://www.rcrwireless.com/20200904/5g/ericsson-deploys-5g-network-near-texas-hq-to-run-real-world-use-cases>.

21. Ericsson has contracted and partnered with the largest nationwide cellular carriers, including Verizon, to perform services and/or deliver products nationwide, including in this District, as explained further below.

22. Ericsson has longstanding contracts with Verizon to supply wireless telecommunications equipment to be used in enhancing Verizon's nationwide network. *See, e.g.*, <https://www.verizon.com/about/news/vzw/2011/01/pr2011-01-07g> (Ericsson is "a primary infrastructure provider for Verizon Wireless' 4G LTE Mobile Broadband network" and "is developing solutions that will take advantage of the increased speed and low latency of 4G networks"); <https://www.fiercewireless.com/operators/ericsson-wins-8-3b-5g-deal-verizon-its-largest-contract-ever> (reporting on Ericsson's 2021 announcement that it had won an \$8.3 billion

5G deal with Verizon—its largest contract ever—to provide 5G equipment for Verizon’s network).

23. During the infringing time period, Ericsson placed infringing products into the stream of commerce via an established distribution channel through its contracts and partnership with Verizon with the knowledge and/or understanding that such products were being offered for sale, and or sold to customers, and/or utilized in this District.

24. Joinder of the Verizon and Ericsson Defendants in this action is proper under 35 U.S.C. § 299(a). Upon information and belief, much of Procomm’s right to relief against the Verizon and Ericsson Defendants for their infringement of the Asserted Patents arises out of the same series of transactions or occurrences, namely in their cooperation and coordination in planning, designing, developing, testing, operating, and maintaining Verizon’s 5G network, including specifically within this District. Additionally, questions of fact common to all Defendants will arise in this action.

25. Venue in this District is proper in this judicial district pursuant to 28 U.S.C. §§ 1391 and 1400(b). The Verizon Defendants and Ericsson USA have each committed acts of infringement within this District and have regular and established places of business here within the meaning of 28 U.S.C § 1400(b). LM Ericsson is a foreign corporation and, pursuant to 28 U.S.C. § 1391(c)(3), may be sued in any judicial district.

III. THE ASSERTED PATENTS

26. The ’100 Patent, entitled “Distributed Remote Base Station System,” was lawfully issued by the United States Patent and Trademark Office (“USPTO”) on November 12, 2013. A true and correct copy of the ’100 Patent is attached as **Exhibit A**.

27. The ’100 Patent is valid and enforceable and was duly issued in full compliance with Title 35 of the United States Code.

28. Procomm is the owner of all right, title, and interest in the '100 Patent, including the right to sue for past and current infringement.

29. The '377 Patent, entitled "Small Signal Threshold and Proportional Gain Distributed Digital Communications," was lawfully issued by the USPTO on September 5, 2006. The '377 Patent claims priority to U.S. Provisional Application No. 60/430,435 ("the '435 Provisional"), filed on December 3, 2002. A true and correct copy of the '377 Patent is attached as **Exhibit B**.

30. The '377 Patent is valid and enforceable and was duly issued in full compliance with Title 35 of the United States Code.

31. Procomm is the owner of all right, title, and interest in the '377 Patent, including the right to sue for past and current infringement.

32. The '721 Patent, entitled "System and Method for Tuning Multicavity Filters," was lawfully issued by the USPTO on November 16, 2010. The '721 Patent claims foreign priority to Italian Application No. MI2007A001276, filed on June 26, 2007. A true and correct copy of the '721 Patent is attached as **Exhibit C**.

33. The '721 Patent is valid and enforceable and was duly issued in full compliance with Title 35 of the United States Code.

34. Procomm is the owner of all right, title, and interest in the '721 Patent, including the right to sue for past and current infringement.

35. The '813 Patent, entitled "Panel Antenna Having Sealed Radio Enclosure," was lawfully issued by the USPTO on July 30, 2013. The patent application that issued as the '813 Patent is a continuation-in-part of PCT/US2009/066345, filed on December 2, 2009. The '813 Patent claims priority to U.S. Provisional Application No. 61/119,114, filed on December 2, 2008.

A true and correct copy of the '813 Patent is attached as **Exhibit D**.

36. The '813 Patent is valid and enforceable and was duly issued in full compliance with Title 35 of the United States Code.

37. Procomm is the owner of all right, title, and interest in the '813 Patent, including the right to sue for past and current infringement.

38. The '521 Patent, entitled "Systems and Methods for Venturi Fan-Assisted Cooling," was lawfully issued by the USPTO on May 25, 2010. A true and correct copy of the '521 Patent is attached as **Exhibit E**.

39. The '521 Patent is valid and enforceable and was duly issued in full compliance with Title 35 of the United States Code.

40. Procomm is the owner of all right, title, and interest in the '521 Patent, including the right to sue for past and current infringement.

41. Procomm asserts and alleges that Verizon and Ericsson have each infringed and continue to infringe at least one claim of each of the '100, '377, '813, and '521 Patents.

42. Procomm asserts and alleges that Verizon has infringed and continues to infringe at least one claim of the '721 Patent.

IV. FACTUAL ALLEGATIONS

A. INTRODUCTION

43. The inventions claimed in the Asserted Patents were developed by engineers at Andrew LLC f/k/a/ Andrew Corporation, ADC Telecommunications, Inc. ("ADC"), and CommScope, Inc. Andrew Corporation was founded in 1937 to manufacture equipment for directional antennas used in AM Radio broadcasts. Over the decades, Andrew Corporation became a leading global supplier and developer of wireless network equipment, hardware, and infrastructure.

44. On June 27, 2007, CommScope, Inc.—a network infrastructure provider based in Hickory, North Carolina—announced its acquisition of Andrew Corporation for approximately \$2.6 billion. As described in a 2007 press release: “The combined company will be a global leader in infrastructure solutions for communications networks, including structured cabling solutions for business and enterprise, broadband cable and apparatus for cable television applications; and antenna and cable products, base station subsystems, coverage and capacity systems, and network solutions for wireless applications.” [https://www.commscope.com/press-releases/2007/commscope-to-acquire-andrew-for-\\$2.6-billion/](https://www.commscope.com/press-releases/2007/commscope-to-acquire-andrew-for-$2.6-billion/).

45. ADC was founded in 1935 as the Audio Development Company. Over the decades, ADC became a leading supplier and developer of wireless networking equipment, hardware, and infrastructure. On July 13, 2010, TE Connectivity announced its acquisition of ADC for approximately \$1.25 billion. On January 28, 2015, CommScope announced its acquisition of TE Connectivity in an all-cash deal for \$3.0 billion.

46. The Asserted Patents were subsequently acquired by and assigned to Procomm.

47. To the extent necessary, Procomm has complied with all applicable requirements of 35 U.S.C. § 287 at all relevant times for each of the Asserted Patents. To the extent necessary, on information and belief, each prior owner of the Asserted Patents has complied with all applicable requirements of 35 U.S.C. § 287 at all relevant times for each of the Asserted Patents.

B. ERICSSON’S PARTNERSHIP WITH VERIZON

48. Verizon is in the business of providing wireless telephone services throughout the United States, including in the State of Texas and in this District. In conjunction with its partner Ericsson, Verizon has deployed wireless networks according to the 5G and other telecommunications standards (“Verizon Networks”). *See, e.g.,*

<https://www.verizon.com/coverage-map/> (last visited January 2, 2024). Both red and dark orange indicate 5G coverage with Verizon Networks:

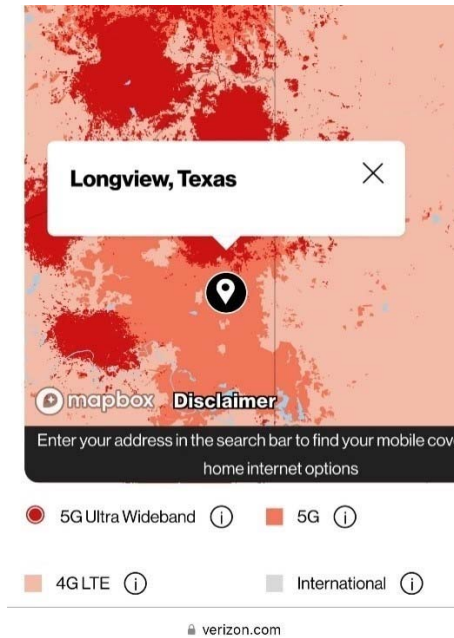

49. On information and belief, much of the equipment installed in the Verizon Networks—especially the 5G Verizon Networks—which incorporates infringing technology was acquired from its longtime partner Ericsson, which designs, manufactures, imports, and sells 5G and other telecommunications equipment, including Ericsson’s Macro, Massive MIMO, Street Macro and Small Cell products

50. Ericsson has partnered with Verizon since at least 2011 to deploy wireless telecommunications infrastructure equipment nationwide, including in this District. *See, e.g.*, <https://www.verizon.com/about/news/vzw/2011/01/pr2011-01-07g>; *IPCom GmbH & Co. KG v. AT&T Inc., and Ericsson Inc., Intervenor*, 2:20-cv-00322-JRG, D.I. 62, at 2-4 (E.D. Tex. Feb. 19, 2021) (Ericsson has “suppl[ied] 3G, 4G LTE, and 5G telecommunications equipment to Verizon” pursuant to an “agreement under which Ericsson supplies ... network equipment.”). For example, Verizon declared that Ericsson is one of its “primary network vendors for [its] LTE

network deployments for macro sites as well as small cells.”

<https://www.sec.gov/Archives/edgar/data/0000732712/000119312517050292/>

[d296602d10k.htm](https://www.ericsson.com/en/pressreleases/2018/7/verizon-and-ericsson-expand-4g-lte-partnership-prepare-for-5g-launch); *see also* <https://www.ericsson.com/en/pressreleases/2018/7/verizon-and-ericsson-expand-4g-lte-partnership-prepare-for-5g-launch>

(stating Ericsson “continue[s] to work closely with Verizon to expand the strategic partnership between our companies, enabling Verizon to unleash the latest in 4G technology and simultaneously prepare to launch 5G in these new markets.”).

51. As relevant here, Ericsson contracted with Verizon to provide wireless telecommunications equipment for Verizon’s commercial 5G launch, beginning with deployment of Ericsson’s products in the second half of 2018. *See, e.g.*, <https://www.ericsson.com/en/press-releases/2017/12/verizon-awards-5g-contract-to-ericsson>. In 2020, Verizon was the first U.S. telecommunications carrier to receive a commercial 5G mmWave Street Macro base station from Ericsson’s Lewisville, Texas factory. <https://www.fiercewireless.com/operators/ericsson-wins-8-3b-5g-deal-verizon-its-largest-contract-ever>. Later that year, Ericsson announced that its partnership with Verizon to drive advancements in 5G technology had led to being the first in the world to demonstrate 5G peak speeds of 5.06 Gbps. <https://www.ericsson.com/en/press-releases/6/2020/verizon-ericsson-and-qualcomm-first-in-the-world-to-achieve-5g-peak-speed-of-5.06-gbps>. In 2021, Ericsson announced that it had won an \$8.3 billion 5G deal with Verizon—its largest contract ever—to provide 5G radio access network (RAN) technology for C-band, low-band and mmWave spectrum. <https://www.fiercewireless.com/operators/ericsson-wins-8-3b-5g-deal-verizon-its-largest-contract-ever>.

C. THE ACCUSED PRODUCTS

52. Upon information and belief, Ericsson makes, uses, sells, and/or offers to sell in the United States, and/or imports in the United States, 5G and other cellular communications

equipment, including associated software. Non-limiting examples of Ericsson’s accused products include at least Ericsson’s Macro, Massive MIMO, Street Macro and Small Cell products and other similar products, such as Ericsson’s Street Macro 6701 discussed below (the “Ericsson Accused Products”).

53. Verizon has partnered with Ericsson to deploy infringing technology supplied by Ericsson—*i.e.*, the Ericsson Accused Products—in the Verizon Networks.

54. Other companies have also partnered with Ericsson to deploy infringing technology supplied by Ericsson—*i.e.*, the Ericsson Accused Products

55. Verizon has also deployed infringing technology in the Verizon Networks from other manufacturers apart from Ericsson. Non-limiting examples of such infringing technology includes at least the Kaelus KA-6008-8433 Interference Filter and other similar products (“the Additional Verizon Accused Products,” and collectively with the Ericsson Accused Products, the “Accused Products”).

56. Upon information and belief, Ericsson has advised, directed and assisted Verizon in performing acts that comprise infringement of the Asserted Patents, including those utilizing the Accused Products, including those set forth below.

D. DEFENDANTS’ INFRINGING ACTS

57. Defendants have directly infringed, and continue to directly infringe, the Asserted Patents by making, using, selling, and/or offering to sell in the United States, and/or importing into the United States, the Accused Products.

58. The Ericsson and Verizon Defendants have directly infringed, and continue to directly infringe, the Asserted Patents by using, installing, testing, and/or maintaining the Accused Products in the Verizon Networks.

59. The Ericsson Defendants have engaged and continue to engage in a pattern of conduct intended to induce and/or contribute to the infringement of others, such as Verizon. These actions have included and include making, using, selling, offering to sell, and/or importing products that infringe the Asserted Patents.

60. The Verizon Defendants have engaged and continue to engage in a pattern of conduct intended to induce and/or contribute to the infringement of others, such as Verizon's customers. These actions have included and include making, using, selling, offering to sell, and/or importing products that infringe the Asserted Patents.

61. There is an actual, substantial, and continuing justiciable controversy between Procomm and all Defendants regarding Defendants' infringement of the Asserted Patents. Such infringement has caused damage to Procomm and absent a judgment from this Court, Defendants will continue to infringe the Asserted Patents and continue to cause damage to Procomm.

62. Upon information and belief, Ericsson has had actual knowledge of the '100 Patent since prior to the filing of this Complaint. For example, an international patent application claiming priority to the application that issued as the '100 Patent was cited during prosecution of Ericsson's International Application No. PCT/EP2013/070734.

63. Upon information and belief, Ericsson has had actual knowledge of the '377 Patent since prior to the filing of this Complaint. For example, the '377 Patent was cited during prosecution of Ericsson's U.S. Patent No. 8,670,722.

64. Upon information and belief, Ericsson has had actual knowledge of the '521 Patent since prior to the filing of this Complaint. For example, the published patent application that issued as the '521 Patent was cited during prosecution of Ericsson's U.S. patent application No. 17/298,854.

65. Upon information and belief, Ericsson has had actual knowledge of the '813 Patent since prior to the filing of this Complaint. For example, the '813 Patent was cited in an International Search Report during prosecution of Ericsson's International Application No. PCT/CN2019/128767.

66. Upon information and belief, Ericsson, as a large technology company, has had knowledge of or should have had knowledge of the Asserted Patents, at least because Ericsson was developing technology and applying for patents in the same field as the Asserted Patents.

67. Although Ericsson has had knowledge or should have had knowledge of the Asserted Patents, at least for the reasons explained above and in any event through the filing and service of this Complaint, Ericsson has engaged, and continues to engage, in behavior that, as a large technology company, it knew or should have known had a high likelihood of infringing the Asserted Patents, including by incorporating Procomm's patented technology in the Ericsson Accused Products. To the extent that Ericsson, as a large technology company, failed to investigate its infringement upon learning of the Asserted Patents, Ericsson has been willfully blind.

68. Ericsson's infringement of each Asserted Patent is and has been willful. Ericsson continues to commit acts of infringement despite awareness of the Asserted Patents and a high likelihood that its actions constitute infringement. Ericsson knew or should have known that its actions constituted an unjustifiably high risk of infringement, at least because, upon information and belief, Ericsson is and has been familiar with the Asserted Patents and the fields to which they relate (including the fields to which Ericsson's Accused Products relate) as part of its development of the Ericsson Accused Products and its monitoring of the Asserted Patents.

69. Ericsson's acts of infringement have been willful as of the date it became aware of the patented technology/invention(s) and/or the Asserted Patents, and no later than the filing of this Complaint for patent infringement and/or the date that Ericsson received or otherwise became aware of this Complaint for patent infringement.

70. Upon information and belief, Verizon, as a large technology company, has had knowledge of or should have had knowledge of the Asserted Patents, at least because Verizon was developing technology and applying for patents in the same field as the Asserted Patents, as well as through Verizon's partnership with Ericsson regarding infringing aspects of the Verizon Networks..

71. Although Verizon has had knowledge or should have had knowledge of the Asserted Patents, at least for the reasons explained above and in any event through the filing and service of this Complaint, as well as the value of and benefits of the technology claimed by the Asserted Patents, Verizon has engaged, and continues to engage, in behavior that, as a large technology company, it knew or should have known had a high likelihood of infringing the Asserted Patents. To the extent that Verizon, as a large technology company, failed to investigate its infringement upon learning of the Asserted Patents, Verizon has been willfully blind.

72. Verizon's infringement of the Asserted Patent is and has been willful. Verizon continues to commit acts of infringement despite awareness of the Asserted Patents and a high likelihood that its actions constitute infringement, and Verizon knew or should have known that its actions constituted an unjustifiably high risk of infringement, at least because of Verizon's familiarity with the Asserted Patents and the fields to which they relate including as part of its deployment of the Accused Products, and its monitoring of patents, patent applications, non-patent

literature, and press in the same fields as the Asserted Patents, including the Asserted Patents themselves.

73. Verizon's acts of infringement have been willful as of the date it became aware of the patented technology/invention(s) and/or the Asserted Patents, and no later than the filing of this Complaint for patent infringement and/or the date that Verizon received or otherwise became aware of this Complaint for patent infringement.

E. COUNT I – INFRINGEMENT OF U.S. PATENT NO. 8,583,100 BY ALL DEFENDANTS

74. Procomm realleges and incorporates by reference each of the preceding paragraphs.

75. Defendants, by themselves and/or through its subsidiaries, agents, and/or business partners, have directly infringed, literally or under the doctrine of equivalents, claims of the '100 Patent pursuant to 35 U.S.C. § 271(a) by making, having made, using, selling, offering for sale, and/or importing devices and methods protected thereby within the United States with respect to at least the Accused Products. By way of example, and without limitation, Defendants have directly infringed at least claims 15 and 19 of the '100 Patent.

76. For example, claim 15 of the '100 Patent recites:

(1.0) A method of transmitting a wireless communication signal comprising:

(1.1) receiving a first RF signal at an antenna of a first remote wireless communication station;

(1.2) processing the first RF signal by a base station at the first remote wireless communication station;

(1.3) generating a second RF signal and a first transport signal representing a duplicate of the second RF signal at the first remote wireless communication station;

(1.4) transmitting the second RF signal from the antenna at the first remote wireless communication station;

- (1.5) routing the first transport signal through a network of remote wireless communication stations to a second remote wireless communication station, each remote wireless communication station having a co-located, network layer router;
- (1.6) transmitting a duplicate of the second RF signal based on the first transport signal from the antenna of the second remote wireless communication station;
- (1.7) receiving a third RF signal at the first remote wireless communication station; and
- (1.8) sending a second transport signal to a host unit based on the second RF signal.

77. By way of example, and again without limitation, Defendants have directly infringed the '100 Patent, and continue to do so, by making, using and selling a device that is capable of performing and allows a user to perform a method that infringes claim 15. For example, with respect to claim 15, upon information and belief, the Accused Products can be and are configured as a distributed system communicating through a network infrastructure to process, generate, and transmit RF signals, and route transport signals. For example, Ericsson's Macro, Massive MIMO, Street Macro and Small Cell products and other similar products contain an antenna, base station, and router capabilities. Upon information and belief, multiple products can be and are configured as a distributed system to process, generate, and transmit RF signals, and route transport signals in the claimed manner. Upon information and belief, Verizon Networks also include other distributed systems and DAS (distributed antenna systems) that use remote wireless communication stations with a network interconnect in the claimed manner.

78. Claim 19 of the '100 Patent recites:

- (1.0) A remote wireless communication station for transmitting high speed wireless data comprising;
 - (1.1) a remote unit;
 - (1.2) a router co-located with and coupled to the remote unit;
 - (1.3) a baseband unit co-located with and coupled to the remote unit;

(1.4) an antenna coupled to the remote unit;

(1.5) wherein the remote unit is configured to send uplink RF sampled data to a host unit based on RF signals received, and is configured to route data corresponding to RF signals transmitted and/or received over a network of remote units of which the remote unit is a member;

(1.6) wherein the baseband unit is configured to generate a first RF signal and a transport signal representing a duplicate of the first RF signal, wherein the remote unit is configured to:

(1.7) process the first RF signal to be transmitted from the antenna coupled to the remote unit; and;

(1.8) send the transport signal over the network to be routed to a second of the remote units, such that a duplicate of the first RF signal can be transmitted from the second of the remote units.

79. By way of example, and again without limitation, Defendants have directly infringed the '100 Patent, and continue to do so, by making, using, and selling devices that infringe claim 19. For example, with respect to claim 19, upon information and belief, the Accused Products can be and are configured as a distributed system communicating through a network infrastructure to process, generate, and transmit RF signals, and route transport signals in the claimed manner. For example, Ericsson's Macro, Massive MIMO, Street Macro and Small Cell products and other similar products contain an antenna, base station, and router capabilities. Upon information and belief, multiple units can be and are configured as a distributed system to process, generate, and transmit RF signals, and send transport signals in the claimed manner. Upon information and belief, Verizon Networks also include other distributed systems and DAS (distributed antenna systems) that use remote wireless communication stations with a network interconnect in the claimed manner.

80. Upon information and belief, the Ericsson and Verizon Defendants, by themselves, together and/or through their subsidiaries, agents, and/or business partners, have

directly infringed, and continue to directly infringe, at least claims 15 and 19 of the '100 Patent under 35 U.S.C. § 271(a) by making, using, selling, offering for sale, installing, testing, and/or maintaining the Accused Products on the Verizon Networks and other networks.

81. Upon information and belief, the Ericsson Defendants, by themselves and/or their subsidiaries, affiliates, agents, and/or business partners, have induced the direct infringement of at least claims 15 and 19 by users of the Accused Products including at least the Verizon Defendants pursuant to 35 U.S.C. § 271(b) by one or more of: making, selling offering to sell, and importing the Accused Products, and through activities relating to selling, marketing, advertising, promotion, support, and distribution of the Accused Products. Upon information and belief, Ericsson had or should have had actual knowledge of the '100 Patent as explained above. Upon information and belief, Ericsson has engaged in these activities with knowledge and intent that such activities would cause and/or encourage direct infringement of the '100 Patent.

82. Upon information and belief, the Ericsson Defendants, by themselves and/or through their subsidiaries, agents, and/or business partners, have contributed to the direct infringement of the '100 Patent by users of the Accused Products, including at least the Verizon Defendants (including, without limitation, the claims addressed above) pursuant to 35 U.S.C. §§ 271(c) and/or 271(f) at least by making, selling, offering to sell, and/or importing or exporting one or components of the Accused Products used to practice one or more claims of the '100 Patent, that constitute a material part of the invention(s) claimed in the '100 Patent, and that have no substantial non-infringing use, with knowledge that such components are especially made or adapted for use in infringing the '100 Patent.

83. Upon information and belief, the Verizon Defendants, by themselves and/or their subsidiaries, affiliates, agents, and/or business partners, have induced the direct infringement of

at least claims 15 and 19 by users of the Accused Products including at least Verizon's customers pursuant to 35 U.S.C. § 271(b) by one or more of: making, selling offering to sell, and importing the Accused Products, and through activities relating to selling, marketing, advertising, promotion, support, and distribution of the Accused Products. Upon information and belief, Verizon had or should have had actual knowledge of the '100 Patent as explained above. Upon information and belief, Verizon has engaged in these activities with knowledge and intent that such activities would cause and/or encourage direct infringement of the '100 Patent.

84. Upon information and belief, the Verizon Defendants, by themselves and/or through their subsidiaries, agents, and/or business partners, have contributed to the direct infringement of the '100 Patent by users of the Accused Products, including at least Verizon's customers (including, without limitation, the claims addressed above) pursuant to 35 U.S.C. § 271(c) at least by making, selling, offering to sell, and/or importing or exporting one or components of the Accused Products used to practice one or more claims of the '100 Patent, that constitute a material part of the invention(s) claimed in the '100 Patent, and that have no substantial non-infringing use, with knowledge that such components are especially made or adapted for use in infringing the '100 Patent.

85. As a consequence of each Defendant's infringement, both literal and under the doctrine of equivalents, of the '100 Patent, Procomm has been damaged in an amount not yet determined and is entitled to recover damages pursuant to 35 U.S.C. § 284.

86. Upon information and belief, as set forth in detail above, Defendants' infringement of the '100 Patent has been and continues to be willful.

F. COUNT II – INFRINGEMENT OF U.S. PATENT NO. 7,103,377 BY ALL DEFENDANTS

87. Procomm realleges and incorporates by reference each of the preceding paragraphs.

88. Defendants, by themselves and/or through their subsidiaries, agents, and/or business partners, have directly infringed, literally or under the doctrine of equivalents, claims of the '377 Patent pursuant to 35 U.S.C. § 271(a) by making, having made, using, selling, offering for sale, and/or importing devices and methods protected thereby within the United States with respect to at least the Accused Products. By way of example, and without limitation, Defendants have directly infringed at least claim 1 of the '377 Patent.

89. For example, claim 1 of the '377 Patent recites:

(1.0) A method for gain distribution in a system comprising a plurality of distributed antennas and a total system dynamic range, the method comprising:

(1.1) sensing a signal level at each of the plurality of distributed antennas;

(1.2) comparing at least one of the plurality of signal levels with a dynamic range fair share threshold; and

(1.3) attenuating each of the at least one of the compared signal levels that is greater than the dynamic range fair share threshold with a gain factor that is determined in response to a remaining portion of the total system dynamic range after attenuation of other signal levels of the plurality of signal levels.

90. By way of example, and again without limitation, Defendants have directly infringed the '377 Patent, and continue to do so, by making, using, and selling a device that is capable of performing and allows a user to perform a method that infringes claim 1. For example, with respect to claim 1, upon information and belief, the Accused Products can be and are configured to perform dynamic resource allocation for distributed antenna systems, including measurement and reallocation of resources to ensure optimal use of available capacity across multiple antennas without risking interference. For example, the Accused Products include an

Interference Sensing feature which realizes coordinated beamforming by sensing over-the-air, which reduces the need for tight scheduler coordination. *See* Massive MIMO Handbook—Technology Primer, Second Edition, at 113 (<https://foryou.ericsson.com/Massive-MIMO-handbook-extended-version-download.html>). The Interference Sensing feature analyzes the network surroundings to obtain interference characteristics and generate an interference profile. *Id.* The Interference Sensing feature generates a set of beamforming weights—jointly optimized towards avoiding generating interference to the neighbor cell users while simultaneously maximizing the signal energy of the serving cell users—using advanced state-of-the-art signal processing techniques. *Id.* The Accused Products also include an Intelligent Cell Shaping feature, which can reduce interference between distributed antennas in unwanted directions, including transmit directions, using advanced AI/ML algorithms to leverage from very large data volumes collected over long periods of time. *Id.* at 114. The Accused Products also include Coordinated Multi-Point Transmission/Reception (CoMP) features, which utilize coordination on the scheduler level to adapt the resource allocation between transmission/reception points to reduce inter-cell interference. *Id.* at 112. For instance, the scheduler can make a dynamic decision to not schedule any user equipment from one or more transmission/reception points, thereby reducing interference to the user equipment served by the remaining transmission/reception points. *Id.* The Accused Products also include Frequency Band interworking features, which offer coverage extension of mid-bands. *Id.* at 159. “By noticing that different physical channels experience different coverage (have different link budgets), weak channels can be moved to a lower band with better coverage, hence being able to use strong channels in mid-band in a larger area.” *Id.*

91. Upon information and belief, the Ericsson and Verizon Defendants, by themselves, together, and/or through their subsidiaries, agents, and/or business partners, have

directly infringed, and continue to directly infringe, at least claim 1 of the '377 Patent under 35 U.S.C. § 271(a) by using, installing, testing, and/or maintaining the Accused Products on the Verizon Networks and other networks.

92. Upon information and belief, the Ericsson Defendants, by themselves and/or their subsidiaries, affiliates, agents, and/or business partners, have induced the direct infringement of at least claim 1 by users of the Accused Products including at least the Verizon Defendants pursuant to 35 U.S.C. § 271(b) by one or more of: making, selling offering to sell, and importing the Accused Products, and through activities relating to selling, marketing, advertising, promotion, support, and distribution of the Accused Products. Upon information and belief, Ericsson had or should have had actual knowledge of the '377 Patent as explained above. Upon information and belief, Ericsson has engaged in these activities with knowledge and intent that such activities would cause and/or encourage direct infringement of the '377 Patent.

93. Upon information and belief, the Ericsson Defendants, by themselves and/or through their subsidiaries, agents, and/or business partners, have contributed to the direct infringement of the '377 Patent by users of the Accused Products, including at least the Verizon Defendants (including, without limitation, the claim addressed above) pursuant to 35 U.S.C. §§ 271(c) and/or 271(f) at least by making, selling, offering to sell, and/or importing or exporting one or components of the Accused Products used to practice one or more claims of the '377 Patent, that constitute a material part of the invention(s) claimed in the '377 Patent, and that have no substantial non-infringing use, with knowledge that such components are especially made or adapted for use in infringing the '377 Patent.

94. Upon information and belief, the Verizon Defendants, by themselves and/or their subsidiaries, affiliates, agents, and/or business partners, have induced the direct infringement of

at least claim 1 by users of the Accused Products including at least Verizon's customers pursuant to 35 U.S.C. § 271(b) by one or more of: making, selling offering to sell, and importing the Accused Products, and through activities relating to selling, marketing, advertising, promotion, support, and distribution of the Accused Products. Upon information and belief, Verizon had or should have had actual knowledge of the '377 Patent as explained above. Upon information and belief, Verizon has engaged in these activities with knowledge and intent that such activities would cause and/or encourage direct infringement of the '377 Patent.

95. Upon information and belief, the Verizon Defendants, by themselves and/or through their subsidiaries, agents, and/or business partners, have contributed to the direct infringement of the '377 Patent by users of the Accused Products, including at least Verizon's customers (including, without limitation, the claim addressed above) pursuant to 35 U.S.C. § 271(c) at least by making, selling, offering to sell, and/or importing or exporting one or components of the Accused Products used to practice one or more claims of the '377 Patent, that constitute a material part of the invention(s) claimed in the '377 Patent, and that have no substantial non-infringing use, with knowledge that such components are especially made or adapted for use in infringing the '377 Patent.

96. As a consequence of each Defendant's infringement, both literal and under the doctrine of equivalents, of the '377 Patent, Procomm has been damaged in an amount not yet determined and is entitled to recover damages pursuant to 35 U.S.C. § 284.

97. Upon information and belief, as set forth in detail above, Defendants' infringement of the '377 Patent has been and continues to be willful.

G. COUNT III – INFRINGEMENT OF U.S. PATENT NO. 8,497,813 BY ALL DEFENDANTS

98. Procomm realleges and incorporates by reference each of the preceding paragraphs.

99. Defendants, by themselves and/or through their subsidiaries, agents, and/or business partners, have directly infringed, literally or under the doctrine of equivalents, claims of the '813 Patent pursuant to 35 U.S.C. § 271(a) by making, having made, using, selling, offering for sale, and/or importing devices and methods protected thereby within the United States with respect to at least the Accused Products. By way of example, and without limitation, Defendants have directly infringed at least claim 1 of the '813 Patent.

100. For example, claim 1 of the '813 Patent recites:

(1.0) A panel antenna, comprising:

(1.1) an enclosure, the enclosure including a rear panel, a first side wall, and a second side wall, a top wall and a bottom wall, the rear panel and the walls defining a cavity, the walls further defining an aperture through which the cavity of the enclosure may be accessed,

(1.2) an internal cover, the internal cover being dimensioned to overlap an area defined by the aperture of the enclosure and providing an environmental seal and electromagnetic shielding for the cavity, the internal cover having at least one RF radiating module fastened to an exterior surface thereof,

(1.3) at least one micro radio mounted to an internal surface of the first side wall, the micro radio being coupled to the RF radiating module;

(1.4) a first heat sink, mounted to an external surface of the first side wall, and

(1.5) a radome, the radome mounting to the internal cover and enclosing the RF radiating module;

(1.6) wherein a flange joins the first and second side walls and the top and bottom wall, and a lip extends from the flange, further defining the aperture through which the cavity of the enclosure may be accessed, the lip being engaged by the internal cover to provide the environmental seal.

101. By way of example, and again without limitation, Defendants have directly infringed the '813 Patent, and continue to do so, by making, using, and selling devices that infringe claim 1. For example, with respect to claim 1, upon information and belief, the Accused Products include integrated units with both passive radiating antenna and active radio

components, organized into isolated compartments with heat dispersing features. For example, as shown in the cross sections below, Ericsson's Street Macro 6701 is a panel antenna that includes a top and back panel which join together to define a cavity (covered by the orange internal cover) in which radio electronics sit. The internal cover overlaps the aperture, isolating the radiating elements in the middle of the orange cover (on top) from the radio electronics underneath.

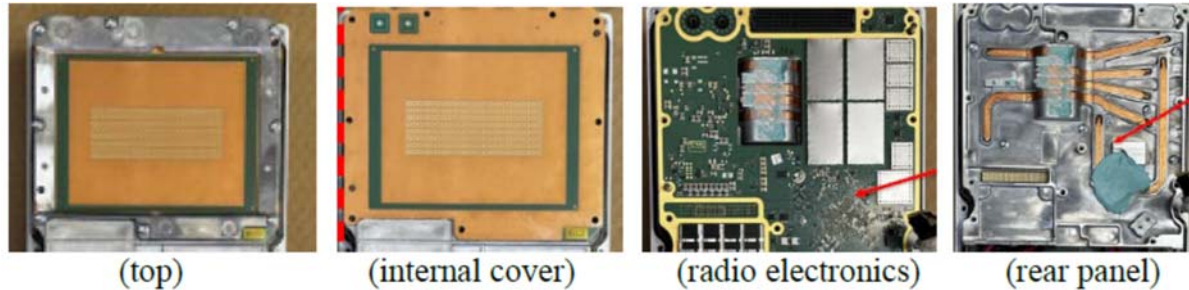

The radio electronics, *e.g.*, micro radio (far left), are mounted to the side wall (near left) at the locations indicated in red below.

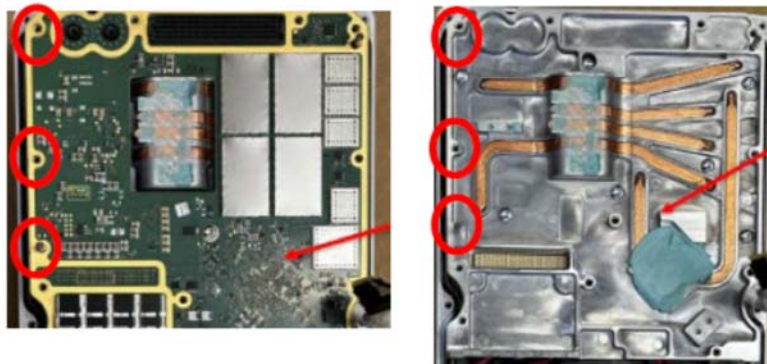

A heat sink (near left) is located below the rear panel and is similarly mounted to the external surface of the first side wall (far left), as shown below.

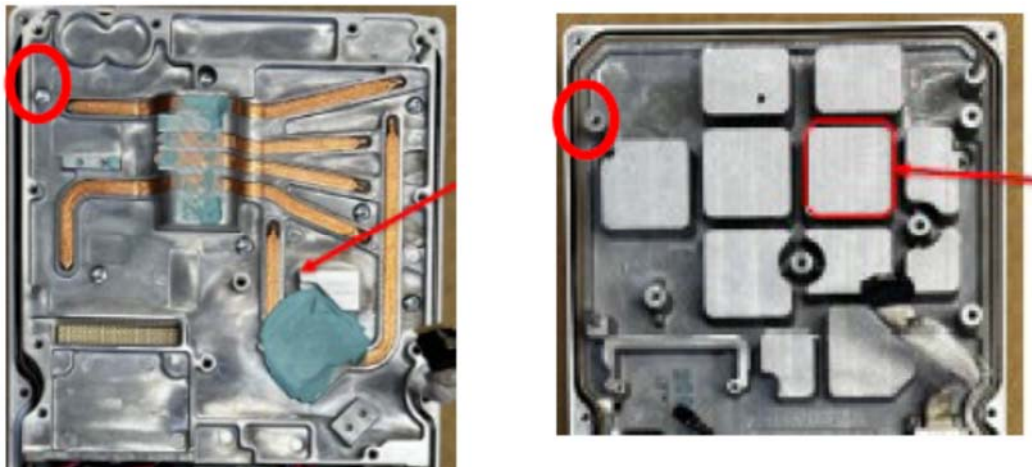

A flange joins the side walls and the top and bottom walls to create a lip that engages the internal cover to provide a seal for the shielding to isolate the radiating elements on the top of the internal cover from the radio electronics as shown above.

102. Upon information and belief, other Accused Products, including but not limited to Ericsson Macro, Massive MIMO, Street Macro and Small Cell products, are similarly configured to infringe the '813 patent, and similarly are used by the Defendants in the Verizon Networks and other networks.

103. Upon information and belief, the Ericsson and Verizon Defendants, by themselves and/or their subsidiaries, affiliates, agents, and/or business partners, have directly infringed, and continue to directly infringe, at least claim 1 of the '813 Patent under 35 U.S.C. § 271(a) by using, installing, testing, and/or maintaining the Accused Products on the Verizon Networks and other networks..

104. Upon information and belief, the Ericsson Defendants, by themselves, together, and/or their subsidiaries, affiliates, agents, and/or business partners, have induced the direct infringement of at least claim 1 by users of the Accused Products including at least the Verizon Defendants pursuant to 35 U.S.C. § 271(b) by one or more of: making, selling offering to sell, and importing the Accused Products, and through activities relating to selling, marketing,

advertising, promotion, support, and distribution of the Accused Products. Upon information and belief, Ericsson had or should have had actual knowledge of the '813 Patent as explained above. Upon information and belief, Ericsson has engaged in these activities with knowledge and intent that such activities would cause and/or encourage direct infringement of the '813 Patent.

105. Upon information and belief, the Ericsson Defendants, by themselves and/or through their subsidiaries, agents, and/or business partners, have contributed to the direct infringement of the '813 Patent by users of the Accused Products, including at least the Verizon Defendants (including, without limitation, the claim addressed above) pursuant to 35 U.S.C. §§ 271(c) and/or 271(f) at least by making, selling, offering to sell, and/or importing or exporting one or components of the Accused Products used to practice one or more claims of the '813 Patent, that constitute a material part of the invention(s) claimed in the '813 Patent, and that have no substantial non-infringing use, with knowledge that such components are especially made or adapted for use in infringing the '813 Patent.

106. Upon information and belief, the Verizon Defendants, by themselves and/or their subsidiaries, affiliates, agents, and/or business partners, have induced the direct infringement of at least claim 1 by users of the Accused Products including at least Verizon's customers pursuant to 35 U.S.C. § 271(b) by one or more of: making, selling offering to sell, and importing the Accused Products, and through activities relating to selling, marketing, advertising, promotion, support, and distribution of the Accused Products. Upon information and belief, Verizon had or should have had actual knowledge of the '813 Patent as explained above. Upon information and belief, Verizon has engaged in these activities with knowledge and intent that such activities would cause and/or encourage direct infringement of the '813 Patent.

107. Upon information and belief, the Verizon Defendants, by themselves and/or through their subsidiaries, agents, and/or business partners, have contributed to the direct infringement of the '813 Patent by users of the Accused Products, including at least Verizon's customers (including, without limitation, the claims addressed above) pursuant to 35 U.S.C. § 271(c) at least by making, selling, offering to sell, and/or importing or exporting one or components of the Accused Products used to practice one or more claims of the '813 Patent, that constitute a material part of the invention(s) claimed in the '813 Patent, and that have no substantial non-infringing use, with knowledge that such components are especially made or adapted for use in infringing the '813 Patent.

108. As a consequence of each Defendant's infringement, both literal and under the doctrine of equivalents, of the '813 Patent, Procomm has been damaged in an amount not yet determined and is entitled to recover damages pursuant to 35 U.S.C. § 284.

109. Upon information and belief, as set forth in detail above, Defendants' infringement of the '813 Patent has been and continues to be willful.

H. COUNT IV – INFRINGEMENT OF U.S. PATENT NO. 7,724,521 BY ALL DEFENDANTS

110. Procomm realleges and incorporates by reference each of the preceding paragraphs.

111. Defendants, by themselves and/or through their subsidiaries, agents, and/or business partners, has directly infringed, literally or under the doctrine of equivalents, claims of the '521 Patent pursuant to 35 U.S.C. § 271(a) by making, having made, using, selling, offering for sale, and/or importing devices and methods protected thereby within the United States with respect to at least the Accused Products. By way of example, and without limitation, Defendants have directly infringed at least claims 1 and 6 of the '521 Patent.

112. For example, claim 1 of the '521 Patent recites:

(1.0) A cooling unit for an enclosure housing electronics, the cooling unit comprising:

(1.1) a fan shroud having at least one electrical fan; and

(1.2) a Venturi chamber having a first inlet for receiving a heated airflow from a heatsink, a second inlet for receiving an airflow from a surrounding environment, and an outlet coupled to the fan shroud, the fan drawing air from the Venturi chamber via the outlet when the fan is on;

(1.3) wherein the Venturi chamber comprises a wall for directing the airflow air from the surrounding environment in from the second inlet and across the heated airflow from the heatsink in a manner to as to draw the heated airflow through the heatsink using a Venturi effect, when the fan is on.

113. By way of example, and again without limitation, Defendants have directly infringed the '521 Patent, and continue to do so, by making, using, and selling devices that infringe claim 1. For example, with respect to claim 1, upon information and belief, the Accused Products include a combination passive/active cooling system for field-deployed RAN equipment. For example, the Ericsson Street Macro 6701 includes an enclosure housing electronics that includes a cooling unit comprising a heat sink (shown assembled in the cross section below) and outer casing.

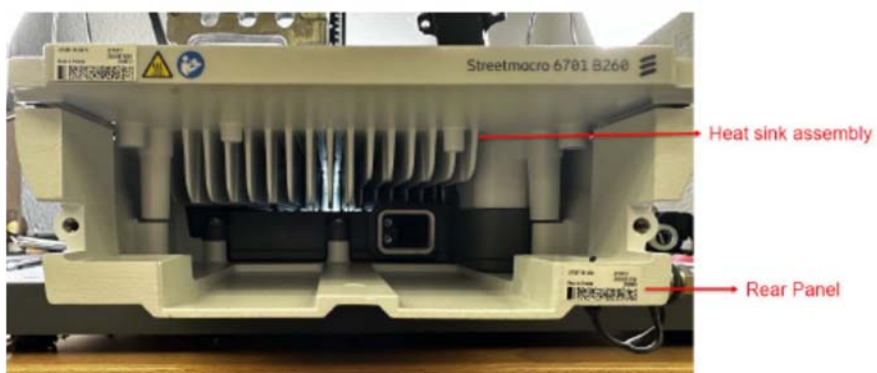
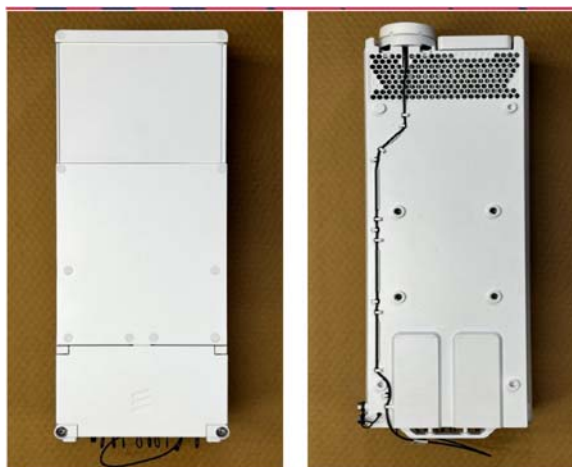

Cooling Unit
(top and bottom)

At one end of the cooling unit is a fan shroud including four electrical fans, emphasized in blue below. The fan shroud includes an outlet for expelling heated air.



The cooling unit includes two inlets. The first (smaller) inlet is parallel to and opposite the fan shroud at the beginning of the heat sink, so that inlet air will be rapidly heated by fins from the heat sink. The second (larger) inlet is on the back cover of the cooling unit chamber, perpendicular to the fan shroud, and will pull in air from the surrounding environment.

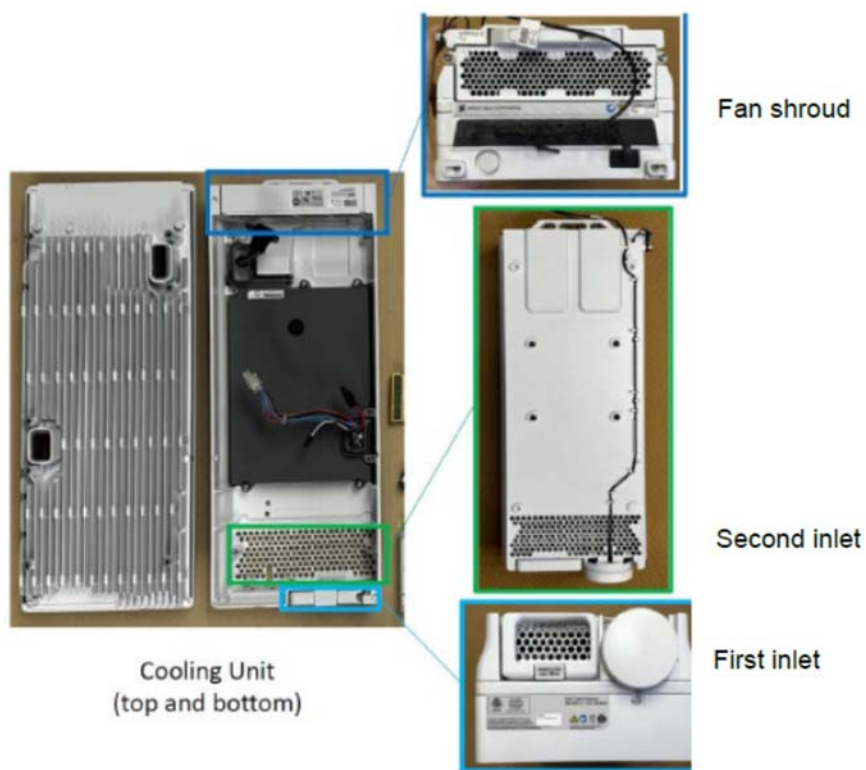

The walls of the chamber create a narrowing path from the second inlet to the outlet of the fan shroud. The airflow from the second inlet—by travelling through a narrowing pathway—creates a Venturi effect of lower pressure, drawing in the heated air from the first inlet.

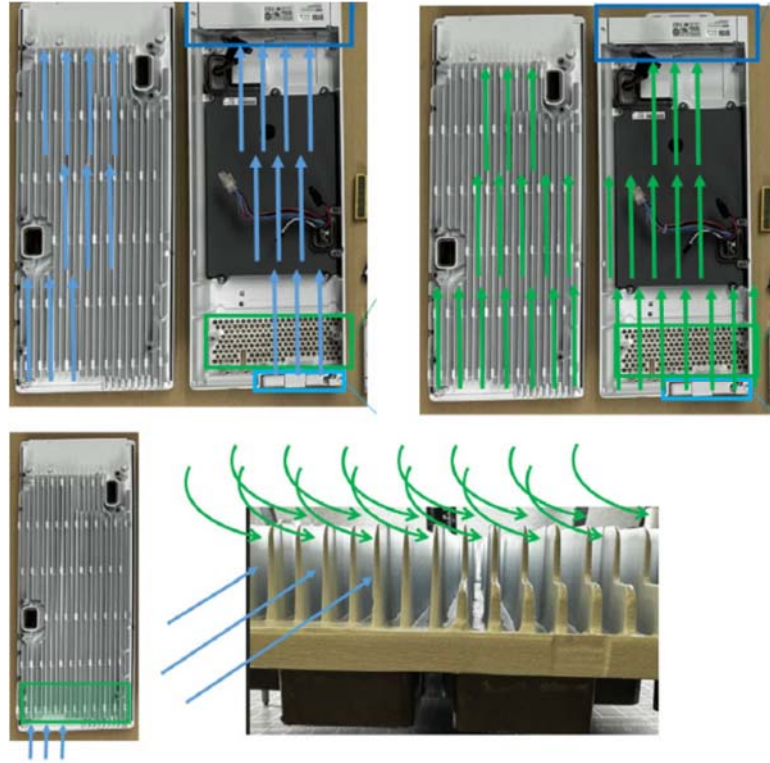

114. Upon information and belief, other Accused Products, including but not limited to Ericsson Macro, Massive MIMO, Street Macro and Small Cell products, are similarly configured to infringe the '521 patent, and similarly are used by the Defendants in the Verizon Networks and other networks.

115. Defendants' making, using, selling, and offering for sale the Accused Products directly infringes claim 1 of the '521 Patent.

116. Claim 6 of the '521 Patent recites:

(1.0) An electronics enclosure, the enclosure comprising:

(1.1) a sealed environment housing electronics, the sealed environment having a heatsink for dissipating heat generated by the electronics to an external environment; and

- (1.2) a cooling unit mounted above the sealed environment;
- (1.3) wherein the cooling unit comprises:
- (1.4) a fan shroud having at least one electrical fan; and
- (1.5) a Venturi chamber having a first inlet for receiving a heated airflow from the heatsink and a second inlet for receiving an airflow from the external environment and an outlet coupled to the fan shroud, the fan shroud drawing air from the Venturi chamber via the outlet when the fan is on;
- (1.6) wherein the Venturi chamber comprises a wall for directing the airflow from the external environment in from the second inlet and across the heated airflow from the heatsink in a manner to as to draw the heated airflow through the heatsink using a Venturi effect, when the fan is on;
- (1.7) wherein the fan shroud is offset with respect to the Venturi chamber so as to not obstruct a natural circulation of air through the heatsink when the fan is not on.

117. By way of example, and again without limitation, Defendants have directly infringed the '521 Patent, and continue to do so, by making, using, and selling devices that infringe claim 6. For example, with respect to claim 6, upon information and belief, the Accused Products include a combination passive/active cooling system for field-deployed RAN equipment. For example, the Ericsson Street Macro 6701 includes an enclosure housing electronics that includes a cooling unit comprising a heat sink (shown assembled in the cross section below) and outer casing.

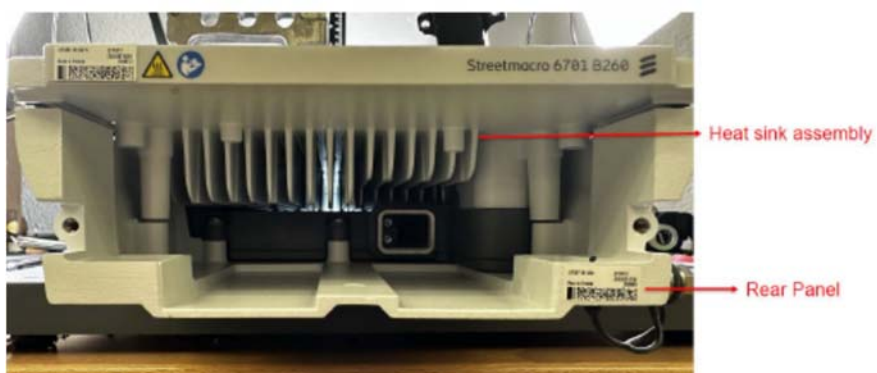
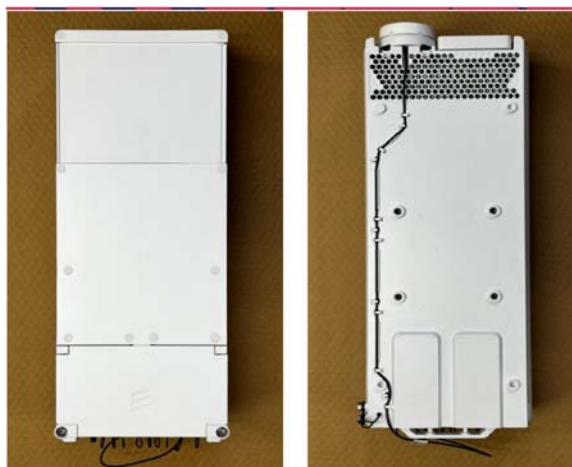

Cooling Unit
(top and bottom)

At one end of the cooling unit is a fan shroud including four electrical fans, emphasized in blue below. The fan shroud includes an outlet for expelling heated air.



The cooling unit includes two inlets. The first (smaller) inlet is parallel to and opposite the fan shroud at the beginning of the heat sink, so that inlet air will be rapidly heated by fins from the heat sink. The second (larger) inlet is on the back cover of the cooling unit chamber, perpendicular to the fan shroud, and will pull in air from the surrounding environment.

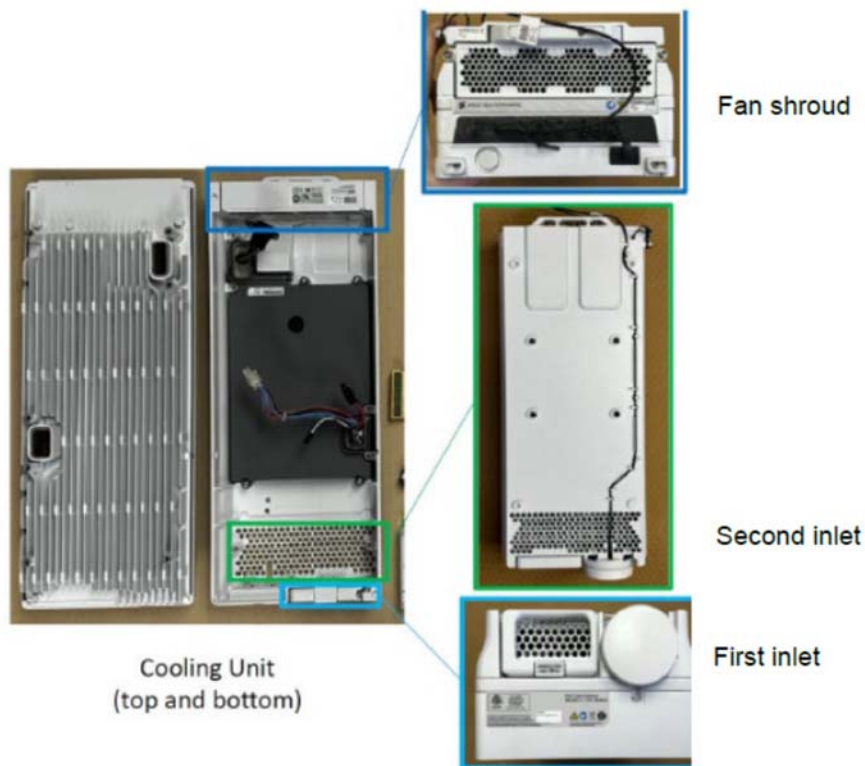

The walls of the chamber create a narrowing path from the second inlet to the outlet of the fan shroud. The airflow from the second inlet—by travelling through a narrowing pathway—creates a Venturi effect of lower pressure, drawing in the heated air from the first inlet.

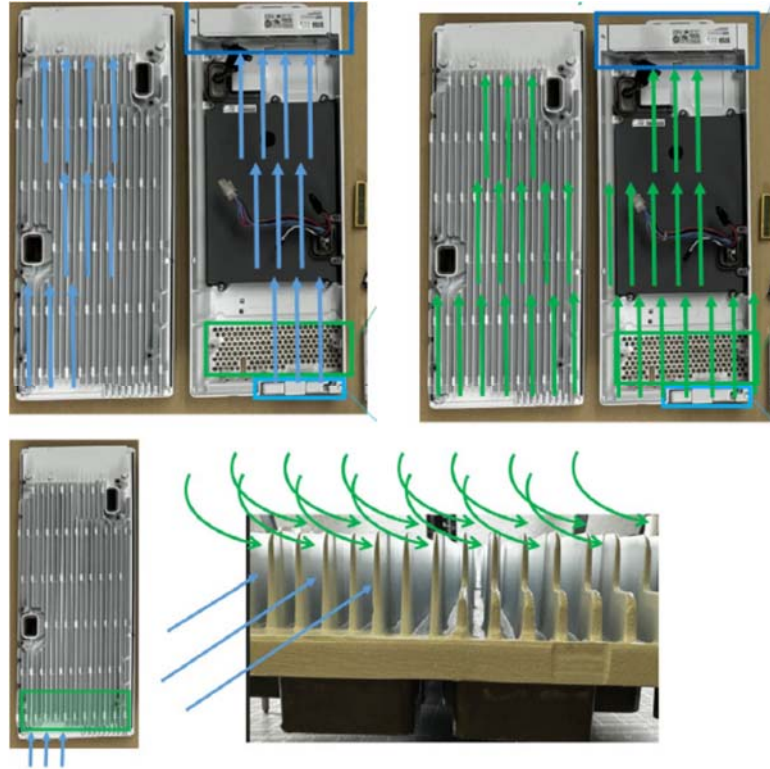

118. Upon information and belief, other Accused Products, including but not limited to Ericsson Macro, Massive MIMO, Street Macro and Small Cell products, are similarly configured to infringe the '813 patent, and similarly are used by the Defendants in the Verizon Networks and other networks.

119. Upon information and belief, the Ericsson and Verizon Defendants, by themselves, together, and/or through their subsidiaries, agents, and/or business partners, have directly infringed, and continue to directly infringe, at least claims 1 and 6 of the '521 Patent under 35 U.S.C. § 271(a) by using, installing, testing, and/or maintaining the Accused Products on the Verizon Networks and other networks.

120. Upon information and belief, the Ericsson Defendants, by themselves and/or their subsidiaries, affiliates, agents, and/or business partners, have induced the direct infringement of at least claims 1 and 6 by users of the Accused Products including at least the Verizon Defendants pursuant to 35 U.S.C. § 271(b) by one or more of: making, selling offering to sell, and importing the Accused Products, and through activities relating to selling, marketing, advertising, promotion, support, and distribution of the Accused Products. Upon information and belief, Ericsson had or should have had actual knowledge of the '521 Patent as explained above. Upon information and belief, Ericsson has engaged in these activities with knowledge and intent that such activities would cause and/or encourage direct infringement of the '521 Patent.

121. Upon information and belief, the Ericsson Defendants, by themselves and/or through their subsidiaries, agents, and/or business partners, have contributed to the direct infringement of the '521 Patent by users of the Accused Products, including at least the Verizon Defendants (including, without limitation, the claims addressed above) pursuant to 35 U.S.C. §§ 271(c) and/or 271(f) at least by making, selling, offering to sell, and/or importing or exporting one or components of the Accused Products used to practice one or more claims of the '521 Patent, that constitute a material part of the invention(s) claimed in the '521 Patent, and that have no substantial non-infringing use, with knowledge that such components are especially made or adapted for use in infringing the '521 Patent.

122. Upon information and belief, the Verizon Defendants, by themselves and/or their subsidiaries, affiliates, agents, and/or business partners, have induced the direct infringement of at least claims 1 and 6 by users of the Accused Products including at least Verizon's customers pursuant to 35 U.S.C. § 271(b) by one or more of: making, selling offering to sell, and importing the Accused Products, and through activities relating to selling, marketing, advertising,

promotion, support, and distribution of the Accused Products. Upon information and belief, Verizon had or should have had actual knowledge of the '521 Patent as explained above. Upon information and belief, Verizon has engaged in these activities with knowledge and intent that such activities would cause and/or encourage direct infringement of the '521 Patent.

123. Upon information and belief, the Verizon Defendants, by themselves and/or through their subsidiaries, agents, and/or business partners, have contributed to the direct infringement of the '521 Patent by users of the Accused Products, including at least Verizon's customers (including, without limitation, the claims addressed above) pursuant to 35 U.S.C. § 271(c) at least by making, selling, offering to sell, and/or importing or exporting one or components of the Accused Products used to practice one or more claims of the '521 Patent, that constitute a material part of the invention(s) claimed in the '521 Patent, and that have no substantial non-infringing use, with knowledge that such components are especially made or adapted for use in infringing the '521 Patent.

124. As a consequence of each Defendant's infringement, both literal and under the doctrine of equivalents, of the '521 Patent, Procomm has been damaged in an amount not yet determined and is entitled to recover damages pursuant to 35 U.S.C. § 284.

125. Upon information and belief, as set forth in detail above, Defendants' infringement of the '521 Patent has been and continues to be willful.

I. COUNT V – INFRINGEMENT OF U.S. PATENT NO. 7,843,721 BY VERIZON DEFENDANTS

126. Procomm realleges and incorporates by reference each of the preceding paragraphs.

127. Verizon, by itself and/or through its subsidiaries, agents, and/or business partners, has directly infringed, and continues to directly infringe, literally or under the doctrine of

equivalents, claims of the '721 Patent pursuant to 35 U.S.C. § 271(a) by using, installing, testing, and/or maintaining the Additional Verizon Accused Products on Verizon's network. By way of example, and without limitation, Verizon has directly infringed at least claims 1 and 2 of the '721 Patent.

128. Claim 1 of the '721 Patent recites:

- (1.0) System for tuning a simple or complex multicavity high frequency and microwave filter, including a body filter; a removable lid; n resonant cavities in said body filter; n resonant rods, disposed in the middle of each cavity; n tuners passing through the filter lid in correspondence to each resonating rod and tuner moving device, characterized in that:
 - (1.1) a subsystem is associated with each tuner to compensate for vibrations and oscillations; and
 - (1.2) the lid is provided with n slots, which are longitudinally placed over the middle of the cavity and have a length sufficient to assure the tuning in every frequency band.

129. For example, with respect to claim 1, upon information and belief, the Additional Verizon Accused Products include tunable microwave/RF filters that use mechanical translation of resonance rods in the tuning system. For example, upon information and belief, the Kaelus KA-6008-8433 Interference Filter is included in the 2023 Verizon Approved Products Ordering Guide, and Verizon deploys the Kaelus filter in its network. The Kaelus KA-6008-8433 is a tunable filter for 3700-3760 MHz (A Block) and 3700-3980 MHz (A, B, and C Block). These are within the microwave spectrum and as shown below, the filter uses a multicavity design for “8 identical filters, suitable for 8x8 MIMO configuration.” <https://www.kaelus.com/en/rf-conditioning-solutions/interference-filters/ka-6008-8433>.



The Kaelus filter includes resonant cavities, with each cavity including a resonant rod in the middle of the cavity. There are n cavities with n rods disposed in the middle.

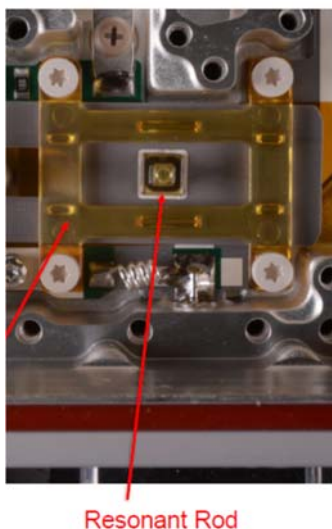

The filter includes n tuners mounted on a slider that correspond to each of the cavities/resonating rods.

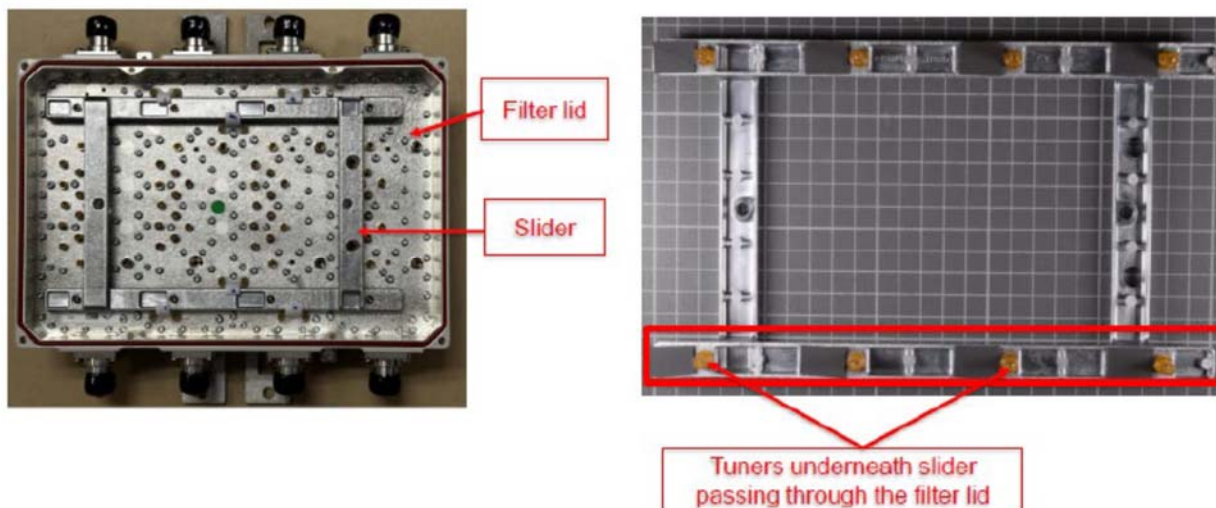

Each tuner includes subsystem to compensate for vibrations and oscillations, as shown in the images above. Further, slots are placed over the middle of the cavity.

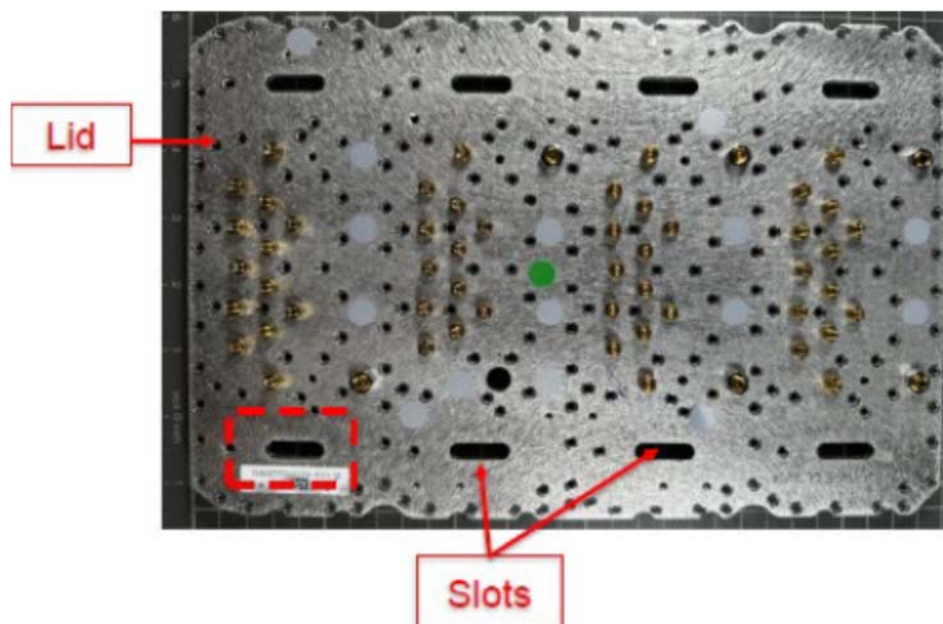

130. As a consequence of Verizon's infringement, both literal and under the doctrine of equivalents, of the '721 Patent, Procomm has been damaged in an amount not yet determined and is entitled to recover damages pursuant to 35 U.S.C. § 284.

131. Upon information and belief, as set forth in detail above, the Verizon Defendants' infringement of the '721 Patent has been and continues to be willful.

JURY DEMAND

132. Pursuant to Rule 38(b), Fed. R. Civ. P., Procomm respectfully demands a trial by jury for all issues so triable.

PRAYER FOR RELIEF

WHEREFORE, Procomm respectfully requests that the Court enter judgment against Defendants:

133. determining that Defendants have infringed, and continue to infringe, one or more claims of the '100, '377, '813, and '521 Patents;

134. ordering Defendants to account for and pay to Procomm all damages suffered by Procomm as a consequence of each Defendant's infringement of the '100, '377, '813, and '521 Patents, together with pre- and post-judgment interest and costs as fixed by the Court;

135. declaring that Defendants' infringement of the '100, '377, '813, and '521 Patents was and is willful and trebling Procomm's damages under 35 U.S.C. § 284 on that ground;

136. determining that Verizon has infringed, and continues to infringe, one or more claims of the '721 Patent;

137. ordering Verizon to account for and pay to Procomm all damages suffered by Procomm as a consequence of Verizon's infringement of the '721 Patent, together with pre- and post-judgment interest and costs as fixed by the Court;

138. declaring that Verizon's infringement of the '721 Patent was and is willful and trebling Procomm's damages under 35 U.S.C. § 284 on that ground;

139. ordering that Defendants be ordered to pay supplemental damages to Procomm, including interest, with an accounting, as needed, of all infringement and/or damages not presented at trial;

140. declaring that this case is exceptional and awarding Procomm its costs and attorney's fees in accordance with 35 U.S.C. § 285; and

141. granting Procomm such other and further relief as the Court may deem just and proper.

Dated: January 8, 2024

Respectfully submitted,

PARKER, BUNT & AINSWORTH, P.C.

/s/ Robert Christopher Bunt
Robert Christopher Bunt
Texas State Bar No. 00787165
100 E. Ferguson Suite 418
Tyler, Texas 75702
Tel. (903) 531-3535
rcbunt@pbatyler.com

Timothy Gilman
tim.gilman@srz.com
Christopher Gerson
chris.gerson@srz.com
Natalie Lieber
natalie.lieber@srz.com
Saunak Desai
saunak.desai@srz.com

Schulte Roth & Zabel LLP
919 Third Avenue
New York, NY 10022
Telephone: 212.756.2000

*Attorneys for Plaintiff Procomm International
Pte. Ltd.*