

**IN THE UNITED STATES DISTRICT COURT
FOR THE EASTERN DISTRICT OF TEXAS
SHERMAN DIVISION**

**ENCRYPTAWAVE TECHNOLOGIES
LLC,**

Plaintiff,

v.

KONICA MINOLTA, INC.,

Defendant.

C.A. No. 4:24-cv-588

JURY TRIAL DEMANDED

PATENT CASE

ORIGINAL COMPLAINT FOR PATENT INFRINGEMENT

Plaintiff Encryptawave Technologies LLC files this Original Complaint for Patent Infringement against Konica Minolta, Inc., and would respectfully show the Court as follows:

I. THE PARTIES

1. Plaintiff Encryptawave Technologies LLC (“Encryptawave” or “Plaintiff”) is a Illinois limited liability company with its address at 23832 Rockfield Boulevard, Suite 170, Lake Forest, CA 92630.

2. On information and belief, Defendant Konica Minolta, Inc. (“Konica Minolta” or “Defendant”) is a corporation organized and existing under the laws of Japan, with its principal place of business at JP TOWER, 2-7-2 Marunouchi, Chiyoda-ku, Tokyo 100-7015, Japan. Konica Minolta may be served may be served pursuant to the provisions of the Hague Convention.

II. JURISDICTION AND VENUE

3. This action arises under the patent laws of the United States, Title 35 of the United States Code. This Court has subject matter jurisdiction of such action under 28 U.S.C. §§ 1331 and 1338(a).

4. On information and belief, Defendant is subject to this Court's specific and general personal jurisdiction, pursuant to due process and the Texas Long-Arm Statute, due at least to its business in this forum, including at least a portion of the infringements alleged herein. Defendant is subject to this Court's general personal jurisdiction pursuant to due process and/or the Texas Long Arm Statute, Tex. Civ. Prac. & Rem. Code § 17.042, due at least to its substantial business conducted in this District, including: (i) having solicited and transacted business in Texas, including benefits directly related to the instant patent infringement causes of action set forth herein; (ii) having placed its products and services into the stream of commerce throughout the United States and having been actively engaged in transacting business in Texas and in this District, and (iii) having committed the complained of tortious acts in Texas and in this District.

5. Without limitation, on information and belief, within this state, Defendant has used the patented inventions thereby committing, and continuing to commit, acts of patent infringement alleged herein. In addition, on information and belief, Defendant has derived revenues from its infringing acts occurring within Texas. Further, on information and belief, Defendant is subject to the Court's general jurisdiction, including from regularly doing or soliciting business, engaging in other persistent courses of conduct, and deriving substantial revenue from goods and services provided to persons or entities in Texas. Further, on information and belief, Defendant is subject to the Court's personal jurisdiction at least due to its sale of Instrumentalities and/or services within Texas. Defendant has committed such purposeful acts and/or transactions in Texas such that it reasonably should know and expect that it could be haled into this Court as a consequence of such activity.

6. Venue is proper in this district under 28 U.S.C. § 1400(b). On information and belief, from and within this District Defendant has committed at least a portion of the infringements

at issue in this case. Furthermore, venue is proper as to Defendant because 28 U.S.C. § 1391(c)(3) provides that “a defendant not resident in the United States may be sued in any judicial district, and the joinder of such a defendant shall be disregarded in determining where the action may be brought with respect to other defendants.”

7. For these reasons, personal jurisdiction exists and venue is proper in this Court under 28 U.S.C. § 1400(b).

III. COUNT I
(PATENT INFRINGEMENT OF UNITED STATES PATENT NO. 7,233,664)

8. Plaintiff incorporates the above paragraphs herein by reference.

9. On June 19, 2007, United States Patent No. 7,233,664 (“the ‘664 Patent”) was duly and legally issued by the United States Patent and Trademark Office. The ‘664 Patent is titled “Dynamic Security Authentication for Wireless Communication Networks.” A true and correct copy of the ‘664 Patent is attached hereto as Exhibit C and incorporated herein by reference.

10. Encryptawave is the assignee of all right, title and interest in the ‘664 patent, including all rights to enforce and prosecute actions for infringement and to collect damages for all relevant times against infringers of the ‘664 Patent. Accordingly, Encryptawave possesses the exclusive right and standing to prosecute the present action for infringement of the ‘664 Patent by Defendant.

11. The invention in the ‘664 Patent relates to the field of wireless communication network security, more particularly to a dynamic authentication method and system for providing secure authentication among wireless communication network nodes. (*Id.* at col. 1:18-22).

12. The objective of cryptography is to allow users to communicate securely through an insecure shared data communications channel while maintaining data integrity, privacy, and user authentication. (*Id.* at col. 1:24-27). Over the past century, cryptographic systems have been

developed that require a great deal of time to break, even when using large computational power. (*Id.* at col. 1:27-30). However, once an encryption key is obtained, the encryption mechanism and likely the entire system security is compromised and a new key is required. (*Id.* at col. 1:30-33). The two most common strategies for make an encryption system difficult to penetrate are: (1) a long encryption key, and/or (2) a complex encryption function. (*Id.* at col. 1:34-37). For example, for an encryption key of length n bits, for large values of n a code breaker would need more than a lifetime to break the cipher. (*Id.* at col. 1:37-39). Simpler encryption functions, such as the logic XOR function, is easy to decipher no matter how long the key length is. (*Id.* at col. 1:39-43). For examples, a logic XOR operation is performed on one bit of data and its corresponding bit from the encryption key, one bit at a time: if the bits are the same then the result is 0 and if the bits are different then the result is 1. (*Id.* at col. 1:43-45). The simple linearity of the XOR function allows an intruder to decipher individual key fragments using a divide-and-conquer approach and then reconstruct the entire key once all the individual fragments are obtained. (*Id.* at col. 1:47-51). A non-linear exponential encryption function, such as Rivest-Sharmi-Adelman (RSA) system, is more difficult to apply a divide-and-conquer approach to break the key. (*Id.* at col. 1:51-54).

13. At the time the patent application was filed, there were two major cryptography system philosophies: 1) symmetric systems (static or semi-dynamic key), and 2) public key systems (static key). (*Id.* at col. 1:55-57). In symmetric systems, a key is exchanged between the users (the sender and receiver) and is used to encrypt and decrypt the data. (*Id.* at col. 1:57-60). There are three main problems with the symmetric system. (*Id.* at col. 1:60-61). First, the exchange of the key between the users introduces a security loophole, which can be alleviated through encrypting the exchanged key using a secure public key cryptography system. (*Id.* at col. 1:61-64). Second, using only one static encryption key makes it easier for an intruder to have

sufficient time to break the key, which can be addressed using multiple session keys that are exchanged periodically. (*Id.* at col. 1:64-66). Third, and most important, is the susceptibility to an insider attack on the key where the time window between exchanging keys might be long enough for a super user, who has super user privileges, to break in and steal the key. (*Id.* at col. 2:1-6).

14. In RSA public key cryptography system, a user generates two related keys, reveals one to the public (“public” key) to be used to encrypt any data sent and a second key that is private to the user (“private” key) that is used to decrypt received data by the user. (*Id.* at col. col. 2:7-11). The RSA cryptography system generates large random primes and multiplies them to get the public key and uses a complex encryption function such as mod and exponential operations, which makes the technique unbreakable in a lifetime for large keys (*e.g.*, higher than 256 bits) and eliminates the problem of insecure exchange of symmetric keys. (*Id.* at col. 2:15-20). However, the huge computational time required by RSA encryption and decryption, in addition to the time to generate the keys, is not appealing to users of the Internet and is therefore mainly used as one-shot solid protection of the symmetric cryptography key exchange. (*Id.* at col. 2:20-25). This one-shot protection, however, allows an internal super user with a helper to generate its own pair of encryption keys and replace the original keys. (*Id.* at col. 2:24-25). The sender then uses the super user’s public key so the super user can decrypt the cipher text, store it, re-encrypt it using the original public key to continue the data to the original recipient for decrypting using the original private key without any knowledge of the break that occurred in the middle (a “super-user-in-the-middle” attack). (*Id.* at col. 2:29-40).

15. Even though both symmetric and public key cryptography systems are secure against outside attack, they are still vulnerable to insider attacks. (*Id.* at col. 2:41-48). A common

way to protect a static encryption key is to save it under a file with restricted access but this cannot prevent a person with super user privileges from accessing the static key of the host file. (*Id.* at col. 2:50-53). Various attempts have been made to circumvent intrusion by outside users, however, they are still prone to attack by super-user-in-the-middle attacks. (*Id.* at col. 2:53 – col. 3:3). The invention in the '664 patent alleviates these problems by providing continuous encryption key modification. (*Id.* at col. 4:26-29).

16. There was a need for security for wireless communications in networks, including allowing mobile communication devices to move between access ports or base stations while maintaining full, mutually secure authentication. (*Id.* at col. 3:4-12). In wireless local area networks, the Wired Equivalent Privacy (WEP) algorithm is used to protect wireless communication from eavesdropping. (*Id.* at col. 3:33-36). WEP relies on a secret encryption key that is shared between a supplicant, such as a wireless laptop personal computer, and an access point. (*Id.* at col. 3:36-39). The secret key is used to encrypt data packets before they are transmitted, and an integrity check is used to ensure that packets are not modified in transit. (*Id.* at col. 3:39-41). The standard does not discuss how the shared key is established; however, in practice, most installations use a single key that is shared between all mobile stations and access points. (*Id.* at col. 3:41-44).

17. Ineffective WEP security lead to different types of attacks by outsiders. (*Id.* at col. 3:60-61). For example, a passive eavesdropper can intercept all wireless traffic and through known methodologies and educated guesses can narrow the field of the contents of a message and possibly determine the exact contents to of the message. (*Id.* at col. 3:45 – col. 4:6). Another type of attack when using a WEP algorithm is if an attacker knows the exact plaintext for one encrypted message, the attacker can use this knowledge to construct correct encrypted packet. (*Id.* at col. 4:7-17).

Therefore, despite the WEP algorithm being part of the standard that describes communications in wireless local area networks, it fails to protect the wireless communications from eavesdropping and unauthorized access to wireless networks, primarily because it relies on a static secret key shared between the supplicant and the wireless network. (*Id.* at col. 4:18-24).

18. There are several benefits to the claimed invention. The key lifetime is too small for an intruder to break and a super-user to copy. (*Id.* at col. 4:29-31). The invention also reduces the computations overhead by breaking the complexity of the encryption function and shifting it over the dynamics of data exchange. (*Id.* at col. 4:32-35). Speed is also improved by using a simple logic encryption function. (*Id.* at col. 4:35-36). Encryption is fully automated and all parties, the source user, destination user, and central authority, are clock-free synchronized and securely authenticated at all times. (*Id.* at col. 4:44-47).

19. The prosecution history of the '664 patent further explains the unconventional features of the claimed invention. The examiner allowed the relevant claims without rejection because the prior art of record did not teach installing a node identifier at a first network node; sending the node identifier information from a first network node to a second network node, and synchronously regenerating an authentication key at two network nodes based upon node identifier information. (Ex. B at 2).

20. **Direct Infringement.** Upon information and belief, Defendant has been directly infringing claim 1 of the '664 patent in Texas, and elsewhere in the United States, by performing actions comprising using or performing the claimed method of providing secure authentication between wireless communication network nodes by using and/or testing the bizhub 227, bizhub 300i, bizhub 301i, bizhub 306i, bizhub 3602P, bizhub 360i, bizhub 361i, bizhub 3622, bizhub 368e, bizhub 4000i, bizhub 4020i, bizhub 4050i, bizhub 4051i, bizhub 4402P, bizhub 4422, bizhub

450i, bizhub 451i, bizhub 4700i, bizhub 4701i, bizhub 4702P, bizhub 4750i, bizhub 4751i, bizhub 4752, bizhub 5000i, bizhub 5020i, bizhub 550i, bizhub 551i, bizhub 650i, bizhub 651i, bizhub 658e, bizhub 750i, bizhub 808, bizhub 850i, bizhub 950i, bizhub 958, bizhub C250i, bizhub C251i, bizhub C287i, bizhub C300i, bizhub C3100i, bizhub C3100i Solution, bizhub C310i, bizhub C3120i, bizhub C3120i Solution, bizhub C3120i Solution Plus, bizhub C3300i, bizhub C3300P, bizhub C3301i, bizhub C3320, bizhub C3320i, bizhub C3321i, bizhub C3350i, bizhub C3351i, bizhub C360i, bizhub C4000i, bizhub C4001i, bizhub C4050i, bizhub C4050i, bizhub C4051i, bizhub C450i, bizhub C451i, bizhub C550i, bizhub C551i, bizhub C650i, bizhub C651i, bizhub C750i, bizhub C751i, bizhub C759 (“Accused Instrumentalities”). (*E.g.*, <https://kmbs.konicaminolta.us/products/multifunction/compact-multifunction/bizhub-c4050i-c3350i/>).

21. For example, in at least internal testing and usage, the system (*e.g.*, a Wi-Fi device network utilizing WPA2 encryption) utilized by the Accused Instrumentalities practices a method of providing secure authentication between wireless communication (*e.g.*, Wi-Fi) network nodes (*e.g.*, the Accused Instrumentalities utilize Wi-Fi to connect to other devices such as computers and access points). The excerpts in this chart are for the bizhub C4050i/C3350i, however, each of the Accused Instrumentalities supports wireless connection with Wi-Fi networks using WPA2 security, which is based on the IEEE 802.11i standard. The accusation of infringement is therefore the same for each of the Accused Instrumentalities as described below. As shown below, the Accused Instrumentalities supports wireless connections with other devices using Wi-Fi. The Accused Instrumentalities utilize WPA2 security, which is based on the IEEE 802.11i standard, to set a password and secure the connection. As shown below, the Accused Instrumentalities can

connect to an access point that is shared by multiple devices which will communicate via a shared network provided by said access point.

The screenshot displays the product page for the Konica Minolta bizhub C4050i / C3350i. The page features a navigation bar with the Konica Minolta logo and various menu items. The main content area includes a large image of the device, a 'KEY FEATURES' section with four icons and text, and a 'Request a Quote' button. Below this, there is a 'Market Place' section with icons for Guides & Manuals, Brochure, Spec Sheet, Drivers, How-to Videos, and Configure. The page also contains several privacy policy notices and a section for 'INTERACTIVE PRODUCT INFORMATION' with a list of features: Security, Intuitive Operability, Mobile Connectivity, and Application Ecosystem.

(E.g., <https://kmb.konicaminolta.us/products/multifunction/compact-multifunction/bizhub-c4050i-c3350i/>)

SYSTEM SPECIFICATIONS

Panel size/resolution	10.1" / 1024 x 600
System memory (standard/max)	5 GB
Solid State Drive	256 GB (standard)
Interface	10/100/1,000-Base-T Ethernet; USB 2.0; <u>Wi-Fi 802.11 b/g/n</u>

(E.g., https://kmbs.konicaminolta.us/wps/wcm/connect/newweb/f1c6642b-226e-43ee-bba0-66ec9ab44b9a/Spec_Sheets_C4050i.pdf?MOD=AJPERES&attachment=false).

SYSTEM FEATURES

Security Functions (standard)	ISO 15408 HCD-PP Common Criteria (in evaluation); IP filtering and port blocking; SSL2; SSL3 and TLS1.0/1.1/1.2 network communication; IPsec support; <u>IEEE 802.1x support</u> ; User authentication; Authentication log; Secure print; Kerberos; Hard disk overwrite (8 standard types); Hard disk data encryption (AES 256); Memory data auto deletion; Confidential fax receipt; Print user data encryption
-------------------------------	--

(E.g., https://kmbs.konicaminolta.us/wps/wcm/connect/newweb/f1c6642b-226e-43ee-bba0-66ec9ab44b9a/Spec_Sheets_C4050i.pdf?MOD=AJPERES&attachment=false).

bizhub C4050i series bizhub C4050i

Konica Minolta, Inc.

device / Wi-Fi / WFA81069

device / Konica Minolta, Inc. / bizhub C4050i

WIFI Certifications			
Device Name	Model(s)	Company	Certification Date
bizhub C4050i series	bizhub C4050i	Konica Minolta, Inc.	2023-07-05
Device Capabilities			
Wi-Fi CERTIFIED™ ac			
WPA3™-Enterprise			
WPA3™-Personal			
▶ Device Certifications			
Device Name	Model(s)	Company	Certification Date
bizhub C4050i series	bizhub C4050i	Konica Minolta, Inc.	2020-04-27
Device Capabilities			
Wi-Fi CERTIFIED™ ac			
WPA3™-Enterprise			
WPA3™-Personal			
▶ Device Certifications			
Device Name	Model(s)	Company	Certification Date
bizhub C4050i series	bizhub C4050i	Konica Minolta, Inc.	2018-12-06
Device Capabilities			
Wi-Fi CERTIFIED™ ac			
▼ Device Certifications			
Security: Protected Management Frames			
Connectivity: Wi-Fi CERTIFIED™ ac			
Connectivity: Wi-Fi CERTIFIED™ n			
Access: Wi-Fi Protected Setup™			
Optimization: WMM®			
Security: WPA2™-Enterprise			
Security: WPA2™-Personal			

(E.g., <https://device.report/wifi/WFA81069>).

Wi-Fi Protected Access version 2 (WPA2): Based on the 802.11i wireless security standard, which was finalized in 2004. The most significant enhancement to WPA2 over WPA is the use of the Advanced Encryption Standard (AES) for encryption. The security provided by AES is sufficient (and approved) for use by the U.S. government to encrypt information classified as top secret — it's probably good enough to protect your secrets as well!

(E.g., <https://www.dummies.com/computers/computer-networking/wireless/wireless-security-protocols-wep-wpa-and-wpa2/>).

Wi-Fi Security: WEP & WPA / WPA2

An overview or tutorial about the IEEE 802.11 standards for Wi-Fi and WLAN applications and the associated WLAN equipment and the use of Wifi hotspots.

WiFi IEEE 802.11 Includes:

[Wi-Fi IEEE 802.11 introduction](#) [Standards](#) [Security](#) [How to stay safe on public Wi-Fi](#) [Wi-Fi Bands](#)
[Router location & coverage](#) [How to buy the best Wi-Fi router](#) [Wi-Fi boosters, range extenders & repeaters](#)
[Wi-Fi wired & powerline extender](#)

Wi-Fi network security is an issue of importance to all Wi-Fi users. It is defined under the IEEE standard 802.11i and security schemes like as WEP, WPA, WPA2 and WPA3 are widely mentioned, with keys or codes being provided for the various Wi-Fi hotspots in use.

Wi-Fi security is of significant importance because very many people use it: at home, in the office and when they are on the move. As the wireless signal can be picked up by non-authorized users, it is imperative to ensure that they cannot access the system.

Even users who legitimately gain access to a system could they try to hack other computers on the same hotspot.

(E.g., <https://www.electronics-notes.com/articles/connectivity/wifi-ieee-802-11/security-wep-wpa-wpa2.php>).

5.1.1.4 Interaction with other IEEE 802[®] layers

IEEE Std 802.11 is required to appear to higher layers [logical link control (LLC)] as a wired IEEE 802 LAN. This requires that the IEEE 802.11 network handle STA mobility within the MAC sublayer. To meet reliability assumptions (that LLC makes about lower layers), it is necessary for IEEE Std 802.11 to incorporate functionality that is untraditional for MAC sublayers.

In a robust security network association (RSNA), IEEE Std 802.11 provides functions to protect data frames, IEEE Std 802.1X-2004 provides authentication and a Controlled Port, and IEEE Std 802.11 and IEEE Std 802.1X-2004 collaborate to provide key management. All STAs in an RSNA have a corresponding IEEE 802.1X entity that handles these services. This standard defines how an RSNA utilizes IEEE Std 802.1X-2004 to access these services.

(E.g., https://standards.ieee.org/standard/802_11-2007.html).

5.2.3.2 RSNA

An RSNA defines a number of security features in addition to wired equivalent privacy (WEP) and IEEE 802.11 authentication. These features include the following:

- Enhanced authentication mechanisms for STAs
- Key management algorithms
- Cryptographic key establishment
- An enhanced data cryptographic encapsulation mechanism, called Counter mode with Cipher-block chaining Message authentication code Protocol (CCMP), and, optionally, Temporal Key Integrity Protocol (TKIP).

An RSNA relies on several components external to the IEEE 802.11 architecture.

The first component is an IEEE 802.1X port access entity (PAE). PAEs are present on all STAs in an RSNA and control the forwarding of data to and from the medium access control (MAC). An AP always implements the Authenticator PAE and Extensible Authentication Protocol (EAP) Authenticator roles, and a non-AP STA always implements the Supplicant PAE and EAP peer roles. In an IBSS, each STA implements both the Authenticator PAE and Supplicant PAE roles and both EAP Authenticator and EAP peer roles.

A second component is the Authentication Server (AS). The AS may authenticate the elements of the RSNA itself, i.e., the non-AP STAs; and APs may provide material that the RSNA elements can use to authenticate each other. The AS communicates through the IEEE 802.1X Authenticator with the IEEE 802.1X Supplicant on each STA, enabling the STA to be authenticated to the AS and vice versa. An RSNA depends upon the use of an EAP method that supports mutual authentication of the AS and the STA, such as those that meet the requirements in IETF RFC 4017. In certain applications, the AS may be integrated into the same physical device as the AP, or into a STA in an IBSS.

(E.g., https://standards.ieee.org/standard/802_11-2007.html).

Wireless LAN Adapter

To display: >>View

Configure a setting to operate this machine as a wireless LAN adapter and connect to your access point.

Setting	Description
[Direct Input]	Select this option to directly enter all the setting items such as SSID and the encryption scheme that are required for a connection. For details on settings, refer to the settings of [Direct Input] shown below.
[WPS]	Select this option to automatically obtain information required for a connection from the access point. The access point must support the WPS function. When Web Connection is used by specifying the IP address of this machine connected to the wireless network, Web Connection is disconnected if WPS is executed. For details on settings, refer to the settings of [WPS] shown below.
[Connection status]	Select this option to check the access point connected to this machine, the radio field intensity of the access point, and the current communication speed.

Settings of [Direct Input]

Setting	Description
[AP Search]	Automatically searches for an access point around this machine. Select an access point to be connected to this machine from the displayed list.
[SSID]	Enter the SSID of the access point to be connected to this machine (using up to 32 bytes).
[Authentication/Encryption Algorithm]	Select the algorithm used for authentication or encryption (default: [No Authentication/Encryption]).
[WEP Key]	Set [WEP Key] when [WEP] is selected in [Authentication/Encryption Algorithm] <input checked="" type="checkbox"/> [Key Input Method]: Select the method to enter the WEP key. <input checked="" type="checkbox"/> [WEP Key]: Enter the WEP key. <input checked="" type="checkbox"/> [Key Selection]: Select the required WEP keys.
[Passphrase Input Method]	Select the passphrase entry method when an algorithm other than [WEP] or [No Authentication/Encryption] is selected in [Authentication/Encryption Algorithm]
[Passphrase]	Specify the passphrase when an algorithm other than [WEP] or [No Authentication/Encryption] is selected in [Authentication/Encryption Algorithm]

(E.g., https://manuals.konicaminolta.eu/bizhub-C4050i-C3350i/EN/bizhub_c4050i-c3350i/contents/opkey_594_S.html).

22. Upon information and belief, the system utilized by the Accused Instrumentalities (e.g., a Wi-Fi device network utilizing WPA2 encryption) practices providing a node identifier comprising an address (e.g., MAC address) and an initial authentication key (e.g., Pre-Shared key

or Pairwise master key). As shown below, the Accused Instrumentalities supports wireless connections with other devices using Wi-Fi. The Accused Instrumentalities utilizes WPA2 security, which is based on the IEEE 802.11i standard, to set a password and secure the connection. The Accused Instrumentalities can connect to various devices using Wi-Fi. In order to utilize Wi-Fi connections protected by WPA2 security, device MAC addresses and an initial authentication key (*e.g.*, Wi-Fi password which is a pre-shared key or pairwise master key) are shared. As shown below, KONICA MINOLTA provides the Accused Instrumentalities with a MAC address when said product is manufactured, and a user of the Accused Instrumentalities can provide an initial authentication key (*i.e.*, a password, security key) during configuration of the Accused Instrumentalities.

(E.g., <https://kmb.konicaminolta.us/products/multifunction/compact-multifunction/bizhub-c4050i-c3350i/>)

SYSTEM SPECIFICATIONS

Panel size/resolution	10.1" / 1024 x 600
System memory (standard/max)	5 GB
Solid State Drive	256 GB (standard)
Interface	10/100/1,000-Base-T Ethernet; USB 2.0; <u>Wi-Fi 802.11 b/g/n</u>

(E.g., https://kmb.konicaminolta.us/wps/wcm/connect/newweb/f1c6642b-226e-43ee-bba0-66ec9ab44b9a/Spec_Sheets_C4050i.pdf?MOD=AJPERES&attachment=false).

bizhub C4050i series bizhub C4050i

Konica Minolta, Inc.

Device: Wi-Fi WFA81069

Device: Konica Minolta, Inc. bizhub C4050i

WiFi Certifications

Device Name	Model(s)	Company	Certification Date
bizhub C4050i series	bizhub C4050i	Konica Minolta, Inc.	2023-07-05

Device Capabilities
 Wi-Fi CERTIFIED™ ac
 WPA3™-Enterprise
 WPA3™-Personal

▶ Device Certifications

Device Name	Model(s)	Company	Certification Date
bizhub C4050i series	bizhub C4050i	Konica Minolta, Inc.	2020-04-27

Device Capabilities
 Wi-Fi CERTIFIED™ ac
 WPA3™-Enterprise
 WPA3™-Personal

▶ Device Certifications

Device Name	Model(s)	Company	Certification Date
bizhub C4050i series	bizhub C4050i	Konica Minolta, Inc.	2018-12-06

Device Capabilities
 Wi-Fi CERTIFIED™ ac

▼ Device Certifications

- Security: Protected Management Frames
- Connectivity: Wi-Fi CERTIFIED™ ac
- Connectivity: Wi-Fi CERTIFIED™ n
- Access: Wi-Fi Protected Setup™
- Optimization: WMM ♻️
- Security: WPA2™-Enterprise
- Security: WPA2™-Personal

(E.g., <https://device.report/wifi/WFA81069>).

So not surprisingly, along with an IP address (which is networks software), there's also a hardware address. Typically it is tied to a key connection device in your computer called the network interface card, or NIC. The NIC is essentially a computer circuit card that makes it possible for your computer to connect to a network.

An NIC turns data into an electrical signal that can be transmitted over the network.

Hey Nick. Meet Mac.

Every NIC has a hardware address that's known as a MAC, for Media Access Control. Where IP addresses are associated with TCP/IP (networking software), MAC addresses are linked to the hardware of network adapters.

A MAC address is given to a network adapter when it is manufactured. It is hardwired or hard-coded onto your computer's network interface card (NIC) and is unique to it. Something called the ARP (Address Resolution Protocol) translates an IP address into a MAC address. The ARP is like a passport that takes data from an IP address through an actual piece of computer hardware.

(E.g., <https://whatismyipaddress.com/mac-address>).

- 802.11 frames have up to four address fields in the MAC header.
- 802.11 frames typically use only three of the MAC address fields (4 in WDS environment).

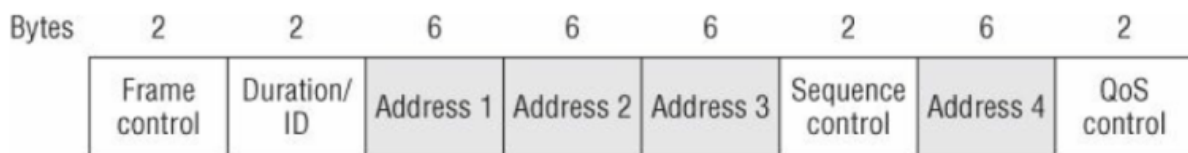

Figure 9.3 802.11 MAC header

(E.g., <https://dot11ap.wordpress.com/ieee-802-11-frame-format-vs-ieee-802-3-frame-format/>).

Depending on whether the 802.11 traffic is upstream or downstream, the definition of each of the four MAC address fields in the layer 2 header will change.

The five definitions are as follows:

- **Source Address (SA)** The MAC address of the original sending station is known as the SA. The source address can originate from either a wireless station or the wired network.
- **Destination Address (DA)** The MAC address that is the final destination of the layer 2 frame is known as the DA. The final destination may be a wireless station or could be a destination on the wired network such as a server or a router.

(E.g., <https://dot11ap.wordpress.com/ieee-802-11-frame-format-vs-ieee-802-3-frame-format/>).

WPA-PSK

WPA-PSK uses this kind of key-encryption system to protect Wi-Fi networks. When you set a WPA-PSK password on the router, you are actually setting the key which the WPA standard will use to encrypt data. When users type in this matching key as their "password" their computers will be able to communicate with the router. Otherwise, they can't join the network because their computers will be incapable of understanding anything the router sends them. There is no such thing as a "default" key in key-based encryption methods. If your router is broadcasting with WPA-PSK, it means that someone with administrative access to the router enabled encryption with a key of his own choosing.

(E.g., <https://smallbusiness.chron.com/default-wpapsk-wifi-39458.html>).

IEEE 802.11 defines two authentication methods: Open System authentication and Shared Key authentication. Open System authentication admits any STA to the DS. Shared Key authentication relies on WEP to demonstrate knowledge of a WEP encryption key. The IEEE 802.11 authentication mechanism also allows definition of new authentication methods.

An RSNA also supports authentication based on IEEE 802.1X, or preshared keys (PSKs). IEEE 802.1X authentication utilizes the EAP to authenticate STAs and the AS with one another. This amendment does not specify an EAP method that is mandatory to implement. See 8.4.4 for a description of the IEEE 802.1X authentication and PSK usage within an IEEE 802.11 IBSS.

In an RSNA, IEEE 802.1X Supplicants and Authenticators exchange protocol information via the IEEE 802.1X Uncontrolled Port. The IEEE 802.1X Controlled Port is blocked from passing general data traffic between two STAs until an IEEE 802.1X authentication procedure completes successfully over the IEEE 802.1X Uncontrolled Port.

(E.g., IEEE 802.11i).

5.9.2.2 Operations with PSK

The following AKM operations are carried out when the PMK is a PSK:

- A STA discovers the AP's security policy through passively monitoring Beacon frames or through active probing (shown in Figure 11a). A STA associates with an AP and negotiates a security policy. The PMK is the PSK.
- The 4-Way Handshake using EAPOL-Key frames is used just as with IEEE 802.1X authentication, when an AS is present. See Figure 11c.
- The GTK and GTK sequence number are sent from the Authenticator to the Supplicant just as in the AS case. See Figure 11c and Figure 11d.

(E.g., IEEE 802.11i).

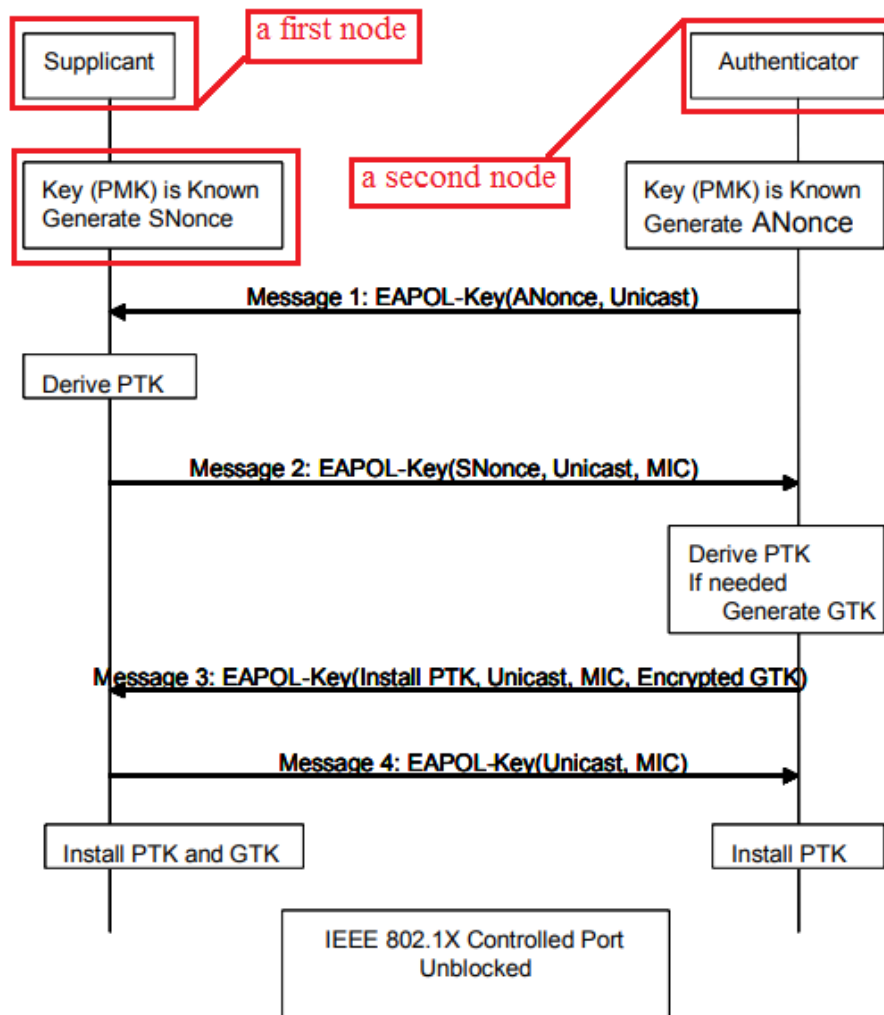

(E.g., IEEE 802.11i).

- b) If an RSNA is based on a PSK in an ESS, the STA's SME establishes an RSNA as follows:
- 1) It identifies the AP as RSNA-capable from the AP's Beacon or Probe Response frames.
 - 2) It shall invoke Open System authentication.
 - 3) It negotiates cipher suites during the association process, as described in 8.4.2 and 8.4.3.
 - 4) It establishes temporal keys by executing a key management algorithm, using the protocol defined by 8.5. It uses the PSK as the PMK.
 - 5) It protects the data link by programming the negotiated cipher suites and the established temporal key into the MAC and then invoking protection.
- c) If an RSNA is based on a PSK in an IBSS, the STA's SME executes the following sequence of procedures:
- 1) It identifies the peer as RSNA-capable from the peer's Beacon or Probe Response frames.

NOTE—STAs may respond to a data MPDU from an unrecognized STA by sending a Probe Request frame to find out whether the unrecognized STA is RSNA-capable.
 - 2) It may optionally invoke Open System authentication.
 - 3) Each STA uses the procedures in 8.5, to establish temporal keys and to negotiate cipher suites. It uses a PSK as the PMK. Note that two peer STAs may follow this procedure simultaneously. See 8.4.9.
 - 4) It protects the data link by programming the negotiated cipher suites and the established temporal key and then invoking protection.

(E.g., IEEE 802.11i).

The screenshot shows the 'User's Guide' for the 'bizhub C4050i/C3350i'. At the top, there are navigation buttons for Home, Print, Scan, Fax, Copy, and Box. A search bar is also present. Below the navigation, a breadcrumb trail reads 'Home > Descriptions of Functions / Utility Keys > Network'. The main content area is titled 'Descriptions of Functions / Utility Keys' and features a left-hand navigation tree. Under 'Utility', 'Administrator', and 'Network' are expanded. The 'Network' section is highlighted in blue. Below the navigation tree, there is a search box for setup buttons and a 'Print this page' button. The main content area is titled 'Network' and includes a 'To display: >>View' button. A paragraph states: 'Configure the network function such as setting up TCP/IP and configuring your environment for Scan TX.' Below this is a table with two columns: 'Setting' and 'Description'. The table lists various settings with links to their respective pages. The '[MAC Address]' row is highlighted with a red border.

Setting	Description
[VLAN Settings]	Here
[TCP/IP Setting]	Here
[E-mail Setting]	Here
[SIP setting]	Here
[HTTP Server Setting]	Here
[MAC Address]	Here

(E.g., https://manuals.konicaminolta.eu/bizhub-C4050i-C3350i/EN/bizhub_c4050i-c3350i/contents/opkey_514_S.html).

Wireless LAN Adapter

To display: >>View

Configure a setting to operate this machine as a wireless LAN adapter and connect to your access point.

Setting	Description
[Direct Input]	Select this option to directly enter all the setting items such as SSID and the encryption scheme that are required for a connection. For details on settings, refer to the settings of [Direct Input] shown below.
[WPS]	Select this option to automatically obtain information required for a connection from the access point. The access point must support the WPS function. When Web Connection is used by specifying the IP address of this machine connected to the wireless network, Web Connection is disconnected if WPS is executed. For details on settings, refer to the settings of [WPS] shown below.
[Connection status]	Select this option to check the access point connected to this machine, the radio field intensity of the access point, and the current communication speed.

Settings of [Direct Input]

Setting	Description
[AP Search]	Automatically searches for an access point around this machine. Select an access point to be connected to this machine from the displayed list.
[SSID]	Enter the SSID of the access point to be connected to this machine (using up to 32 bytes).
[Authentication/Encryption Algorithm]	Select the algorithm used for authentication or encryption (default: [No Authentication/Encryption]).
[WEP Key]	Set [WEP Key] when [WEP] is selected in [Authentication/Encryption Algorithm]. <input checked="" type="checkbox"/> [Key Input Method]: Select the method to enter the WEP key. <input checked="" type="checkbox"/> [WEP Key]: Enter the WEP key. <input checked="" type="checkbox"/> [Key Selection]: Select the required WEP keys.
[Passphrase Input Method]	Select the passphrase entry method when an algorithm other than [WEP] or [No Authentication/Encryption] is selected in [Authentication/Encryption Algorithm].
[Passphrase]	Specify the passphrase when an algorithm other than [WEP] or [No Authentication/Encryption] is selected in [Authentication/Encryption Algorithm].

(E.g., https://manuals.konicaminolta.eu/bizhub-C4050i-C3350i/EN/bizhub_c4050i-c3350i/contents/opkey_594_S.html).

23. Upon information and belief, the system utilized by the Accused Instrumentalities (e.g., a Wi-Fi device network utilizing WPA2 encryption) practices installing the node identifier (e.g., MAC address and pre-shared key or pairwise master key) at a first network node (e.g., the

Accused Instrumentalities). The Accused Instrumentalities can connect to various devices using Wi-Fi. To utilize Wi-Fi connections protected by WPA2 security, device MAC addresses and an initial authentication key (e.g., Wi-Fi password which is a pre-shared key or pairwise master key) are shared. As shown below, Konica Minolta provides the Accused Instrumentalities with a MAC address, and a user of the Accused Instrumentalities can provide an initial authentication key. The MAC address is installed on the Accused Instrumentalities by Konica Minolta when said product is manufactured. Additionally, after a user provides an initial authentication key (i.e., a password, security key), the initial authentication key is installed on the Accused Instrumentalities.

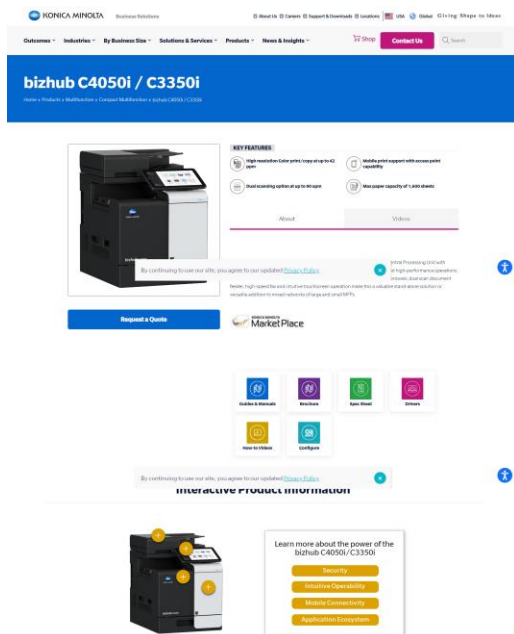

(E.g., <https://kmb.konicaminolta.us/products/multifunction/compact-multifunction/bizhub-c4050i-c3350i/>).

SYSTEM SPECIFICATIONS

Panel size/resolution	10.1" / 1024 x 600
System memory (standard/max)	5 GB
Solid State Drive	256 GB (standard)
Interface	10/100/1,000-Base-T Ethernet; USB 2.0; <u>Wi-Fi 802.11 b/g/n</u>

(E.g., https://kmb.s.konicaminolta.us/wps/wcm/connect/newweb/f1c6642b-226e-43ee-bba0-66ec9ab44b9a/Spec_Sheets_C4050i.pdf?MOD=AJPERES&attachment=false).

bizhub C4050i series bizhub C4050i
Konica Minolta, Inc.

device / Wi-Fi / WFA81069

device / Konica Minolta, Inc. / bizhub C4050i

WiFi Certifications			
Device Name	Model(s)	Company	Certification Date
bizhub C4050i series	bizhub C4050i	Konica Minolta, Inc.	2023-07-05
Device Capabilities			
Wi-Fi CERTIFIED™ ac			
WPA3™-Enterprise			
WPA3™-Personal			
▶ Device Certifications			
Device Name	Model(s)	Company	Certification Date
bizhub C4050i series	bizhub C4050i	Konica Minolta, Inc.	2020-04-27
Device Capabilities			
Wi-Fi CERTIFIED™ ac			
WPA3™-Enterprise			
WPA3™-Personal			
▶ Device Certifications			
Device Name	Model(s)	Company	Certification Date
bizhub C4050i series	bizhub C4050i	Konica Minolta, Inc.	2018-12-06
Device Capabilities			
Wi-Fi CERTIFIED™ ac			
▼ Device Certifications			
Security: Protected Management Frames			
Connectivity: Wi-Fi CERTIFIED™ ac			
Connectivity: Wi-Fi CERTIFIED™ n			
Access: Wi-Fi Protected Setup™			
Optimization: WMM®			
Security: WPA2™-Enterprise			
Security: WPA2™-Personal			

(E.g., <https://device.report/wifi/WFA81069>).

So not surprisingly, along with an IP address (which is networks software), there's also a hardware address. Typically it is tied to a key connection device in your computer called the network interface card, or NIC. The NIC is essentially a computer circuit card that makes it possible for your computer to connect to a network.

An NIC turns data into an electrical signal that can be transmitted over the network.

Hey Nick. Meet Mac.

Every NIC has a hardware address that's known as a MAC, for Media Access Control. Where IP addresses are associated with TCP/IP (networking software), MAC addresses are linked to the hardware of network adapters.

A MAC address is given to a network adapter when it is manufactured. It is hardwired or hard-coded onto your computer's network interface card (NIC) and is unique to it. Something called the ARP (Address Resolution Protocol) translates an IP address into a MAC address. The ARP is like a passport that takes data from an IP address through an actual piece of computer hardware.

(E.g., <https://whatismyipaddress.com/mac-address>).

- 802.11 frames have up to four address fields in the MAC header.
- 802.11 frames typically use only three of the MAC address fields (4 in WDS environment).

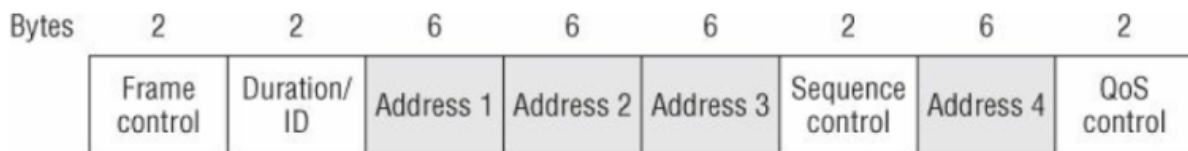

Figure 9.3 802.11 MAC header

(E.g., <https://dot11ap.wordpress.com/ieee-802-11-frame-format-vs-ieee-802-3-frame-format/>).

Depending on whether the 802.11 traffic is upstream or downstream, the definition of each of the four MAC address fields in the layer 2 header will change.

The five definitions are as follows:

- **Source Address (SA)** The MAC address of the original sending station is known as the SA. The source address can originate from either a wireless station or the wired network.
- **Destination Address (DA)** The MAC address that is the final destination of the layer 2 frame is known as the DA. The final destination may be a wireless station or could be a destination on the wired network such as a server or a router.

(E.g., <https://dot11ap.wordpress.com/ieee-802-11-frame-format-vs-ieee-802-3-frame-format/>).

WPA-PSK

WPA-PSK uses this kind of key-encryption system to protect Wi-Fi networks. When you set a WPA-PSK password on the router, you are actually setting the key which the WPA standard will use to encrypt data. When users type in this matching key as their "password" their computers will be able to communicate with the router. Otherwise, they can't join the network because their computers will be incapable of understanding anything the router sends them. There is no such thing as a "default" key in key-based encryption methods. If your router is broadcasting with WPA-PSK, it means that someone with administrative access to the router enabled encryption with a key of his own choosing.

(E.g., <https://smallbusiness.chron.com/default-wpapsk-wifi-39458.html>).

IEEE 802.11 defines two authentication methods: Open System authentication and Shared Key authentication. Open System authentication admits any STA to the DS. Shared Key authentication relies on WEP to demonstrate knowledge of a WEP encryption key. The IEEE 802.11 authentication mechanism also allows definition of new authentication methods.

An RSNA also supports authentication based on IEEE 802.1X, or preshared keys (PSKs). IEEE 802.1X authentication utilizes the EAP to authenticate STAs and the AS with one another. This amendment does not specify an EAP method that is mandatory to implement. See 8.4.4 for a description of the IEEE 802.1X authentication and PSK usage within an IEEE 802.11 IBSS.

In an RSNA, IEEE 802.1X Supplicants and Authenticators exchange protocol information via the IEEE 802.1X Uncontrolled Port. The IEEE 802.1X Controlled Port is blocked from passing general data traffic between two STAs until an IEEE 802.1X authentication procedure completes successfully over the IEEE 802.1X Uncontrolled Port.

(E.g., IEEE 802.11i).

5.9.2.2 Operations with PSK

The following AKM operations are carried out when the PMK is a PSK:

- A STA discovers the AP's security policy through passively monitoring Beacon frames or through active probing (shown in Figure 11a). A STA associates with an AP and negotiates a security policy. The PMK is the PSK.
- The 4-Way Handshake using EAPOL-Key frames is used just as with IEEE 802.1X authentication, when an AS is present. See Figure 11c.
- The GTK and GTK sequence number are sent from the Authenticator to the Supplicant just as in the AS case. See Figure 11c and Figure 11d.

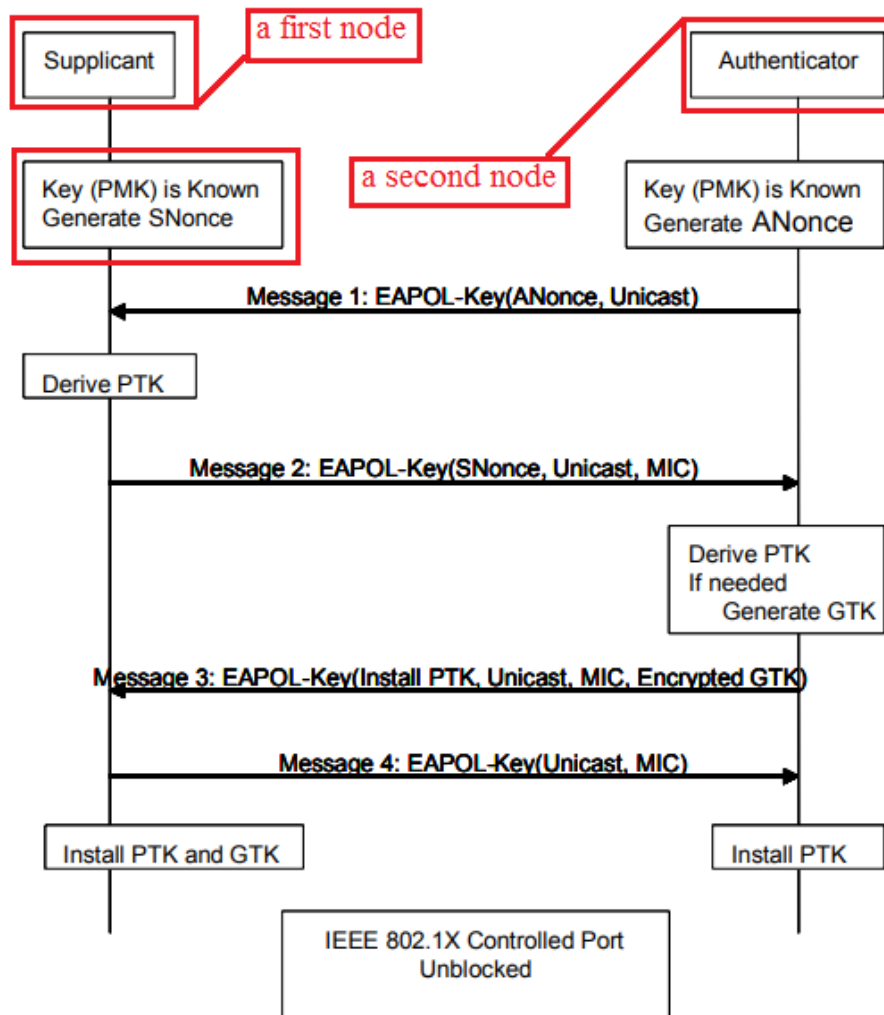

(E.g., IEEE 802.11i).

- b) If an RSNA is based on a PSK in an ESS, the STA's SME establishes an RSNA as follows:
- 1) It identifies the AP as RSNA-capable from the AP's Beacon or Probe Response frames.
 - 2) It shall invoke Open System authentication.
 - 3) It negotiates cipher suites during the association process, as described in 8.4.2 and 8.4.3.
 - 4) It establishes temporal keys by executing a key management algorithm, using the protocol defined by 8.5. It uses the PSK as the PMK.
 - 5) It protects the data link by programming the negotiated cipher suites and the established temporal key into the MAC and then invoking protection.
- c) If an RSNA is based on a PSK in an IBSS, the STA's SME executes the following sequence of procedures:
- 1) It identifies the peer as RSNA-capable from the peer's Beacon or Probe Response frames.

NOTE—STAs may respond to a data MPDU from an unrecognized STA by sending a Probe Request frame to find out whether the unrecognized STA is RSNA-capable.
 - 2) It may optionally invoke Open System authentication.
 - 3) Each STA uses the procedures in 8.5, to establish temporal keys and to negotiate cipher suites. It uses a PSK as the PMK. Note that two peer STAs may follow this procedure simultaneously. See 8.4.9.
 - 4) It protects the data link by programming the negotiated cipher suites and the established temporal key and then invoking protection.

(E.g., IEEE 802.11i).

The screenshot shows the 'User's Guide' for the 'bizhub C4050i/C3350i'. The top navigation bar includes 'Home', 'Print', 'Scan', 'Fax', 'Copy', and 'Box' buttons. A search bar is located in the top right corner. The main content area is titled 'Descriptions of Functions / Utility Keys' and features a left-hand navigation tree. The 'Network' section is expanded, showing sub-items like 'VLAN Settings', 'TCP/IP Setting', and 'WebDAV Settings'. The 'Network' item is highlighted in blue. The main content area displays a search bar for setup buttons and a table of network settings.

Network

To display: >>View

Configure the network function such as setting up TCP/IP and configuring your environment for Scan TX.

Setting	Description
[VLAN Settings]	Here
[TCP/IP Setting]	Here
[E-mail Setting]	Here
[SIP setting]	Here
[HTTP Server Setting]	Here
[MAC Address]	Here

(E.g., https://manuals.konicaminolta.eu/bizhub-C4050i-C3350i/EN/bizhub_c4050i-c3350i/contents/opkey_514_S.html).

Wireless LAN Adapter

To display: >>View

Configure a setting to operate this machine as a wireless LAN adapter and connect to your access point.

Setting	Description
[Direct Input]	Select this option to directly enter all the setting items such as SSID and the encryption scheme that are required for a connection. For details on settings, refer to the settings of [Direct Input] shown below.
[WPS]	Select this option to automatically obtain information required for a connection from the access point. The access point must support the WPS function. When Web Connection is used by specifying the IP address of this machine connected to the wireless network, Web Connection is disconnected if WPS is executed. For details on settings, refer to the settings of [WPS] shown below.
[Connection status]	Select this option to check the access point connected to this machine, the radio field intensity of the access point, and the current communication speed.

Settings of [Direct Input]

Setting	Description
[AP Search]	Automatically searches for an access point around this machine. Select an access point to be connected to this machine from the displayed list.
[SSID]	Enter the SSID of the access point to be connected to this machine (using up to 32 bytes).
[Authentication/Encryption Algorithm]	Select the algorithm used for authentication or encryption (default: [No Authentication/Encryption]).
[WEP Key]	Set [WEP Key] when [WEP] is selected in [Authentication/Encryption Algorithm]. <input checked="" type="checkbox"/> [Key Input Method]: Select the method to enter the WEP key. <input checked="" type="checkbox"/> [WEP Key]: Enter the WEP key. <input checked="" type="checkbox"/> [Key Selection]: Select the required WEP keys.
[Passphrase Input Method]	Select the passphrase entry method when an algorithm other than [WEP] or [No Authentication/Encryption] is selected in [Authentication/Encryption Algorithm].
[Passphrase]	Specify the passphrase when an algorithm other than [WEP] or [No Authentication/Encryption] is selected in [Authentication/Encryption Algorithm].

(E.g., https://manuals.konicaminolta.eu/bizhub-C4050i-C3350i/EN/bizhub_c4050i-c3350i/contents/opkey_594_S.html).

24. Upon information and belief, the system utilized by the Accused Instrumentalities (e.g., a Wi-Fi device network utilizing WPA2 encryption) practices storing the node identifier (e.g., MAC and pre-shared key or pairwise master key) at a second network node (e.g., a second

Wi-Fi device such as a computer or an access point connected to the Accused Instrumentalities). As shown below, when configuring the Accused Instrumentalities to connect to another device via Wi-Fi, a MAC address and initial authentication key (*i.e.*, a password) must be provided. Following said configuration, the Accused Instrumentalities transmits a response for a beacon transmitted by another Wi-Fi device or sends a probe request to the another Wi-Fi device, wherein the header for said beacon response or probe request comprises the MAC address of the sender. The other Wi-Fi device will store the MAC address of the Accused Instrumentalities for use in future communications. Additionally, the Wi-Fi password which is pre-shared key or pairwise master key (*e.g.*, initial authentication key) provided at the Accused Instrumentalities' interface will have been stored at a second network node (*e.g.*, another device such as an access point) where the password was used to create and secure a preexisting Wi-Fi network the Accused Instrumentalities is now joining. As shown below, the Accused Instrumentalities supports wireless connections with other devices using Wi-Fi. The Accused Instrumentalities utilizes WPA2 security, which is based on the IEEE 802.11i standard, to set a password and secure the connection.

The screenshot shows the 'User's Guide' for the 'bizhub C4050i/C3350i'. The top navigation bar includes 'Home', 'Print', 'Scan', 'Fax', 'Copy', and 'Box' buttons. A search bar is located in the top right corner. The left sidebar contains a tree view of the user guide's contents, with 'Network' selected under the 'Utility' section. The main content area is titled 'Network' and contains a table of settings. The 'MAC Address' setting is highlighted with a red box.

Setting	Description
[VLAN Settings]	Here
[TCP/IP Setting]	Here
[E-mail Setting]	Here
[SIP setting]	Here
[HTTP Server Setting]	Here
[MAC Address]	Here

(E.g., https://manuals.konicaminolta.eu/bizhub-C4050i-C3350i/EN/bizhub_c4050i-c3350i/contents/opkey_514_S.html).

Wireless LAN Adapter

To display: >>View

Configure a setting to operate this machine as a wireless LAN adapter and connect to your access point.

Setting	Description
[Direct Input]	Select this option to directly enter all the setting items such as SSID and the encryption scheme that are required for a connection. For details on settings, refer to the settings of [Direct Input] shown below.
[WPS]	Select this option to automatically obtain information required for a connection from the access point. The access point must support the WPS function. When Web Connection is used by specifying the IP address of this machine connected to the wireless network, Web Connection is disconnected if WPS is executed. For details on settings, refer to the settings of [WPS] shown below.
[Connection status]	Select this option to check the access point connected to this machine, the radio field intensity of the access point, and the current communication speed.

Settings of [Direct Input]

Setting	Description
[AP Search]	Automatically searches for an access point around this machine. Select an access point to be connected to this machine from the displayed list.
[SSID]	Enter the SSID of the access point to be connected to this machine (using up to 32 bytes).
[Authentication/Encryption Algorithm]	Select the algorithm used for authentication or encryption (default: [No Authentication/Encryption]).
[WEP Key]	Set [WEP Key] when [WEP] is selected in [Authentication/Encryption Algorithm]. <input checked="" type="checkbox"/> [Key Input Method]: Select the method to enter the WEP key. <input checked="" type="checkbox"/> [WEP Key]: Enter the WEP key. <input checked="" type="checkbox"/> [Key Selection]: Select the required WEP keys.
[Passphrase Input Method]	Select the passphrase entry method when an algorithm other than [WEP] or [No Authentication/Encryption] is selected in [Authentication/Encryption Algorithm].
[Passphrase]	Specify the passphrase when an algorithm other than [WEP] or [No Authentication/Encryption] is selected in [Authentication/Encryption Algorithm].

(E.g., https://manuals.konicaminolta.eu/bizhub-C4050i-C3350i/EN/bizhub_c4050i-c3350i/contents/opkey_594_S.html).

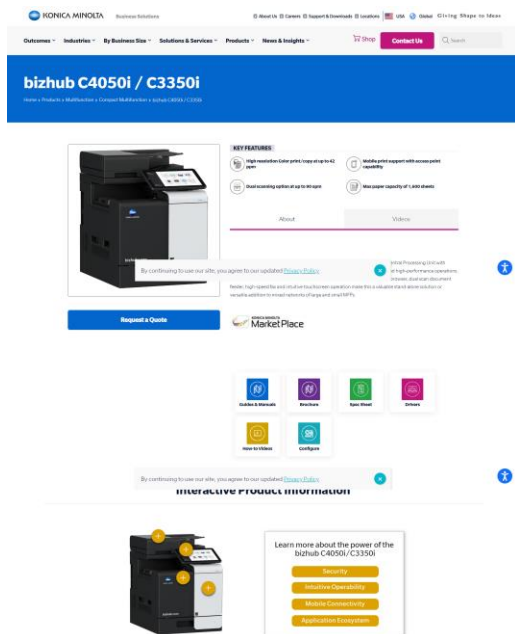

(E.g., <https://kmb.konicaminolta.us/products/multifunction/compact-multifunction/bizhub-c4050i-c3350i/>).

SYSTEM SPECIFICATIONS

Panel size/resolution	10.1" / 1024 x 600
System memory (standard/max)	5 GB
Solid State Drive	256 GB (standard)
Interface	10/100/1,000-Base-T Ethernet; USB 2.0; <u>Wi-Fi 802.11 b/g/n</u>

(E.g., https://kmb.konicaminolta.us/wps/wcm/connect/newweb/f1c6642b-226e-43ee-bba0-66ec9ab44b9a/Spec_Sheets_C4050i.pdf?MOD=AJPERES&attachment=false).

bizhub C4050i series bizhub C4050i

Konica Minolta, Inc.

device / Wi-Fi / WFA81069

device / Konica Minolta, Inc. / bizhub C4050i

WiFi Certifications

Device Name	Model(s)	Company	Certification Date
bizhub C4050i series	bizhub C4050i	Konica Minolta, Inc.	2023-07-05

Device Capabilities

- Wi-Fi CERTIFIED™ ac
- WPA3™-Enterprise
- WPA3™-Personal

▶ Device Certifications

Device Name	Model(s)	Company	Certification Date
bizhub C4050i series	bizhub C4050i	Konica Minolta, Inc.	2020-04-27

Device Capabilities

- Wi-Fi CERTIFIED™ ac
- WPA3™-Enterprise
- WPA3™-Personal

▶ Device Certifications

Device Name	Model(s)	Company	Certification Date
bizhub C4050i series	bizhub C4050i	Konica Minolta, Inc.	2018-12-06

Device Capabilities

- Wi-Fi CERTIFIED™ ac

▼ Device Certifications

- Security: Protected Management Frames
- Connectivity: Wi-Fi CERTIFIED™ ac
- Connectivity: Wi-Fi CERTIFIED™ n
- Access: Wi-Fi Protected Setup™
- Optimization: WMM®
- Security: WPA2™-Enterprise
- Security: WPA2™-Personal

(E.g., <https://device.report/wifi/WFA81069>).

So not surprisingly, along with an IP address (which is networks software), there's also a hardware address. Typically it is tied to a key connection device in your computer called the network interface card, or NIC. The NIC is essentially a computer circuit card that makes it possible for your computer to connect to a network.

An NIC turns data into an electrical signal that can be transmitted over the network.

Hey Nick. Meet Mac.

Every NIC has a hardware address that's known as a MAC, for Media Access Control. Where IP addresses are associated with TCP/IP (networking software), MAC addresses are linked to the hardware of network adapters.

A MAC address is given to a network adapter when it is manufactured. It is hardwired or hard-coded onto your computer's network interface card (NIC) and is unique to it. Something called the ARP (Address Resolution Protocol) translates an IP address into a MAC address. The ARP is like a passport that takes data from an IP address through an actual piece of computer hardware.

(E.g., <https://whatismyipaddress.com/mac-address>).

5.9.2.2 Operations with PSK

The following AKM operations are carried out when the PMK is a PSK:

- A STA discovers the AP's security policy through passively monitoring Beacon frames or through active probing (shown in Figure 11a). A STA associates with an AP and negotiates a security policy. The PMK is the PSK.
- The 4-Way Handshake using EAPOL-Key frames is used just as with IEEE 802.1X authentication, when an AS is present. See Figure 11c.
- The GTK and GTK sequence number are sent from the Authenticator to the Supplicant just as in the AS case. See Figure 11c and Figure 11d.

(E.g., IEEE 802.11i).

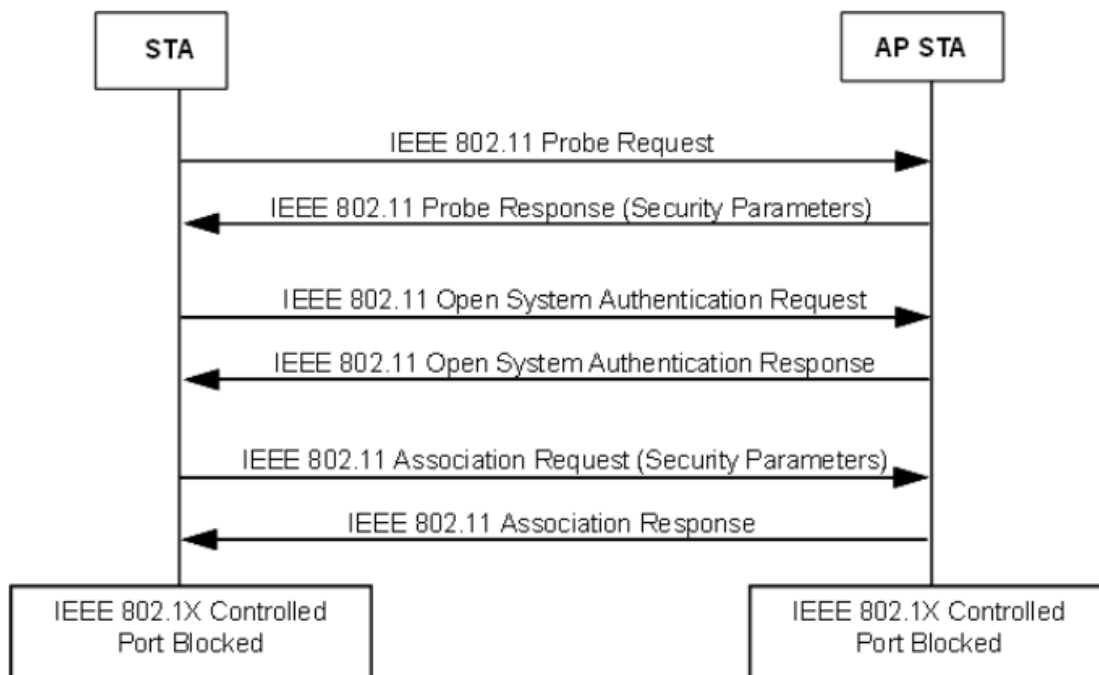

(E.g., IEEE 802.11i).

- 802.11 frames have up to four address fields in the MAC header.
- 802.11 frames typically use only three of the MAC address fields (4 in WDS environment).

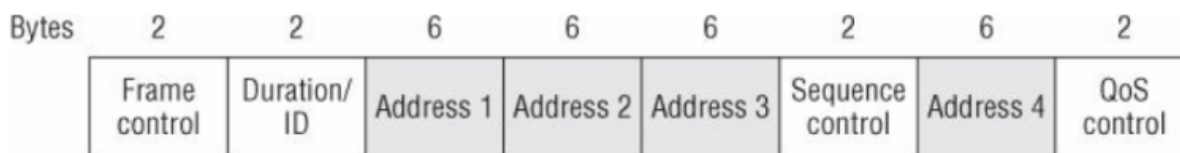

Figure 9.3 802.11 MAC header

(E.g., <https://dot11ap.wordpress.com/ieee-802-11-frame-format-vs-ieee-802-3-frame-format/>).

Depending on whether the 802.11 traffic is upstream or downstream, the definition of each of the four MAC address fields in the layer 2 header will change.

The five definitions are as follows:

- **Source Address (SA)** The MAC address of the original sending station is known as the SA. The source address can originate from either a wireless station or the wired network.
- **Destination Address (DA)** The MAC address that is the final destination of the layer 2 frame is known as the DA. The final destination may be a wireless station or could be a destination on the wired network such as a server or a router.

(E.g., <https://dot11ap.wordpress.com/ieee-802-11-frame-format-vs-ieee-802-3-frame-format/>).

WPA-PSK

WPA-PSK uses this kind of key-encryption system to protect Wi-Fi networks. When you set a WPA-PSK password on the router, you are actually setting the key which the WPA standard will use to encrypt data. When users type in this matching key as their "password" their computers will be able to communicate with the router. Otherwise, they can't join the network because their computers will be incapable of understanding anything the router sends them. There is no such thing as a "default" key in key-based encryption methods. If your router is broadcasting with WPA-PSK, it means that someone with administrative access to the router enabled encryption with a key of his own choosing.

(E.g., <https://smallbusiness.chron.com/default-wpapsk-wifi-39458.html>).

IEEE 802.11 defines two authentication methods: Open System authentication and Shared Key authentication. Open System authentication admits any STA to the DS. Shared Key authentication relies on WEP to demonstrate knowledge of a WEP encryption key. The IEEE 802.11 authentication mechanism also allows definition of new authentication methods.

An RSNA also supports authentication based on IEEE 802.1X, or preshared keys (PSKs). IEEE 802.1X authentication utilizes the EAP to authenticate STAs and the AS with one another. This amendment does not specify an EAP method that is mandatory to implement. See 8.4.4 for a description of the IEEE 802.1X authentication and PSK usage within an IEEE 802.11 IBSS.

In an RSNA, IEEE 802.1X Supplicants and Authenticators exchange protocol information via the IEEE 802.1X Uncontrolled Port. The IEEE 802.1X Controlled Port is blocked from passing general data traffic between two STAs until an IEEE 802.1X authentication procedure completes successfully over the IEEE 802.1X Uncontrolled Port.

(E.g., IEEE 802.11i).

5.9.2.2 Operations with PSK

The following AKM operations are carried out when the PMK is a PSK:

- A STA discovers the AP's security policy through passively monitoring Beacon frames or through active probing (shown in Figure 11a). A STA associates with an AP and negotiates a security policy. The PMK is the PSK.
- The 4-Way Handshake using EAPOL-Key frames is used just as with IEEE 802.1X authentication, when an AS is present. See Figure 11c.
- The GTK and GTK sequence number are sent from the Authenticator to the Supplicant just as in the AS case. See Figure 11c and Figure 11d.

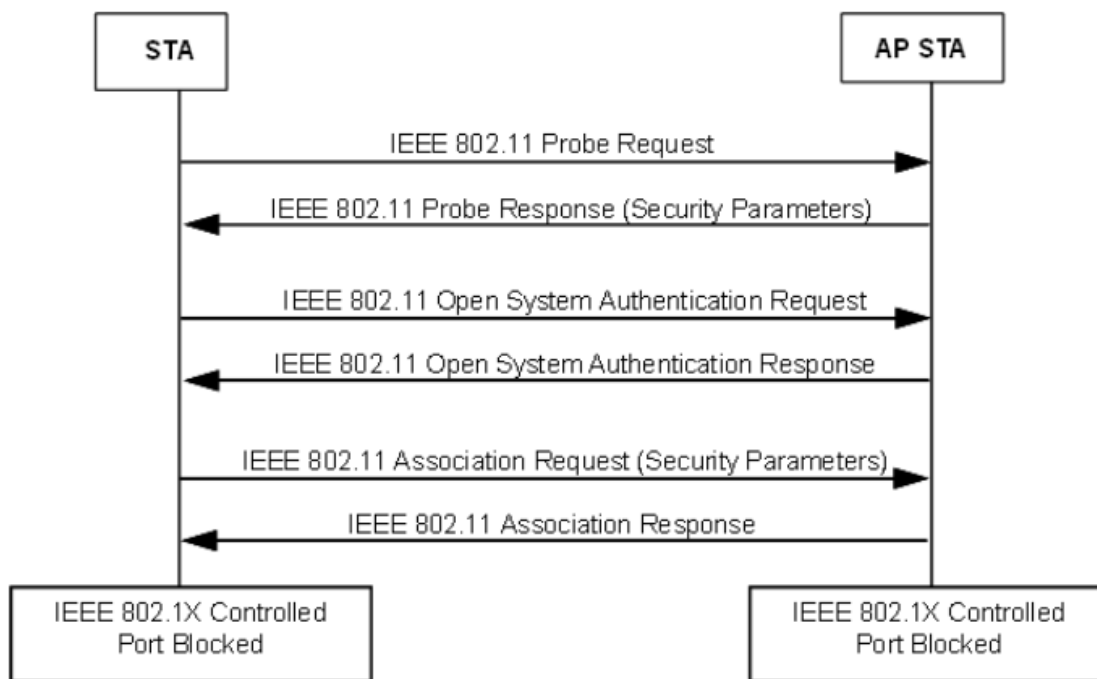

(E.g., IEEE 802.11i).

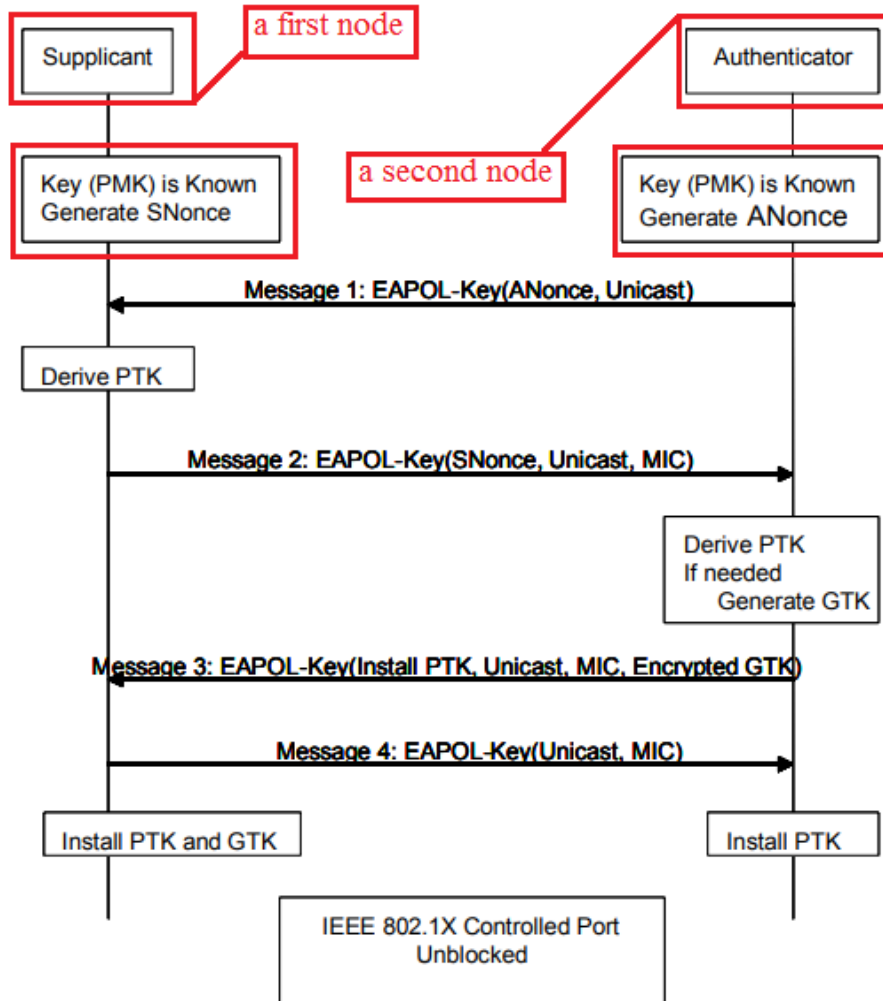

(E.g., IEEE 802.11i).

- b) If an RSNA is based on a PSK in an ESS, the STA's SME establishes an RSNA as follows:
- 1) It identifies the AP as RSNA-capable from the AP's Beacon or Probe Response frames.
 - 2) It shall invoke Open System authentication.
 - 3) It negotiates cipher suites during the association process, as described in 8.4.2 and 8.4.3.
 - 4) It establishes temporal keys by executing a key management algorithm, using the protocol defined by 8.5. It uses the PSK as the PMK.
 - 5) It protects the data link by programming the negotiated cipher suites and the established temporal key into the MAC and then invoking protection.
- c) If an RSNA is based on a PSK in an IBSS, the STA's SME executes the following sequence of procedures:
- 1) It identifies the peer as RSNA-capable from the peer's Beacon or Probe Response frames.

NOTE—STAs may respond to a data MPDU from an unrecognized STA by sending a Probe Request frame to find out whether the unrecognized STA is RSNA-capable.
 - 2) It may optionally invoke Open System authentication.
 - 3) Each STA uses the procedures in 8.5, to establish temporal keys and to negotiate cipher suites. It uses a PSK as the PMK. Note that two peer STAs may follow this procedure simultaneously. See 8.4.9.
 - 4) It protects the data link by programming the negotiated cipher suites and the established temporal key and then invoking protection.

(E.g., IEEE 802.11i).

25. Upon information and belief, the system utilized by the Accused Instrumentalities (e.g., a Wi-Fi device network utilizing WPA2 encryption) practices sending node identifier information (e.g., MAC address of the Accused Instrumentalities and pre-shared key or pairwise master key) from a first network node (e.g., the Accused Instrumentalities) to a second network node (e.g., an access point, computer, etc.). The Accused Instrumentalities sends its MAC address (e.g., address) as well as a key value derived from the pre-shared key or pairwise master key (e.g., initial authentication key) to another Wi-Fi device for authentication, in order to connect to said Wi-Fi device's network. A pairwise temporal key is derived from the pre-shared key or pairwise master key (e.g., initial authentication key). The pairwise temporal key has two parts KCK and KEK. In the authentication process, the Accused Instrumentalities acts as a supplicant. As shown

below, the accessory device transfers a key value derived from KCK in the EAPOL-message 2 to another Wi-Fi device whose network the Accused Instrumentalities is attempting to connect to.

IEEE 802.11 defines two authentication methods: Open System authentication and Shared Key authentication. Open System authentication admits any STA to the DS. Shared Key authentication relies on WEP to demonstrate knowledge of a WEP encryption key. The IEEE 802.11 authentication mechanism also allows definition of new authentication methods.

An RSNA also supports authentication based on IEEE 802.1X, or preshared keys (PSKs). IEEE 802.1X authentication utilizes the EAP to authenticate STAs and the AS with one another. This amendment does not specify an EAP method that is mandatory to implement. See 8.4.4 for a description of the IEEE 802.1X authentication and PSK usage within an IEEE 802.11 IBSS.

In an RSNA, IEEE 802.1X Supplicants and Authenticators exchange protocol information via the IEEE 802.1X Uncontrolled Port. The IEEE 802.1X Controlled Port is blocked from passing general data traffic between two STAs until an IEEE 802.1X authentication procedure completes successfully over the IEEE 802.1X Uncontrolled Port.

5.9.2.2 Operations with PSK

The following AKM operations are carried out when the PMK is a PSK:

- A STA discovers the AP's security policy through passively monitoring Beacon frames or through active probing (shown in Figure 11a). A STA associates with an AP and negotiates a security policy. The PMK is the PSK.
- The 4-Way Handshake using EAPOL-Key frames is used just as with IEEE 802.1X authentication, when an AS is present. See Figure 11c.
- The GTK and GTK sequence number are sent from the Authenticator to the Supplicant just as in the AS case. See Figure 11c and Figure 11d.

(E.g., IEEE 802.11i).

- b) If an RSNA is based on a PSK in an ESS, the STA's SME establishes an RSNA as follows:
- 1) It identifies the AP as RSNA-capable from the AP's Beacon or Probe Response frames.
 - 2) It shall invoke Open System authentication.
 - 3) It negotiates cipher suites during the association process, as described in 8.4.2 and 8.4.3.
 - 4) It establishes temporal keys by executing a key management algorithm, using the protocol defined by 8.5. It uses the PSK as the PMK.
 - 5) It protects the data link by programming the negotiated cipher suites and the established temporal key into the MAC and then invoking protection.
- c) If an RSNA is based on a PSK in an IBSS, the STA's SME executes the following sequence of procedures:
- 1) It identifies the peer as RSNA-capable from the peer's Beacon or Probe Response frames.

NOTE—STAs may respond to a data MPDU from an unrecognized STA by sending a Probe Request frame to find out whether the unrecognized STA is RSNA-capable.
 - 2) It may optionally invoke Open System authentication.
 - 3) Each STA uses the procedures in 8.5, to establish temporal keys and to negotiate cipher suites. It uses a PSK as the PMK. Note that two peer STAs may follow this procedure simultaneously. See 8.4.9.
 - 4) It protects the data link by programming the negotiated cipher suites and the established temporal key and then invoking protection.

(E.g., IEEE 802.11i).

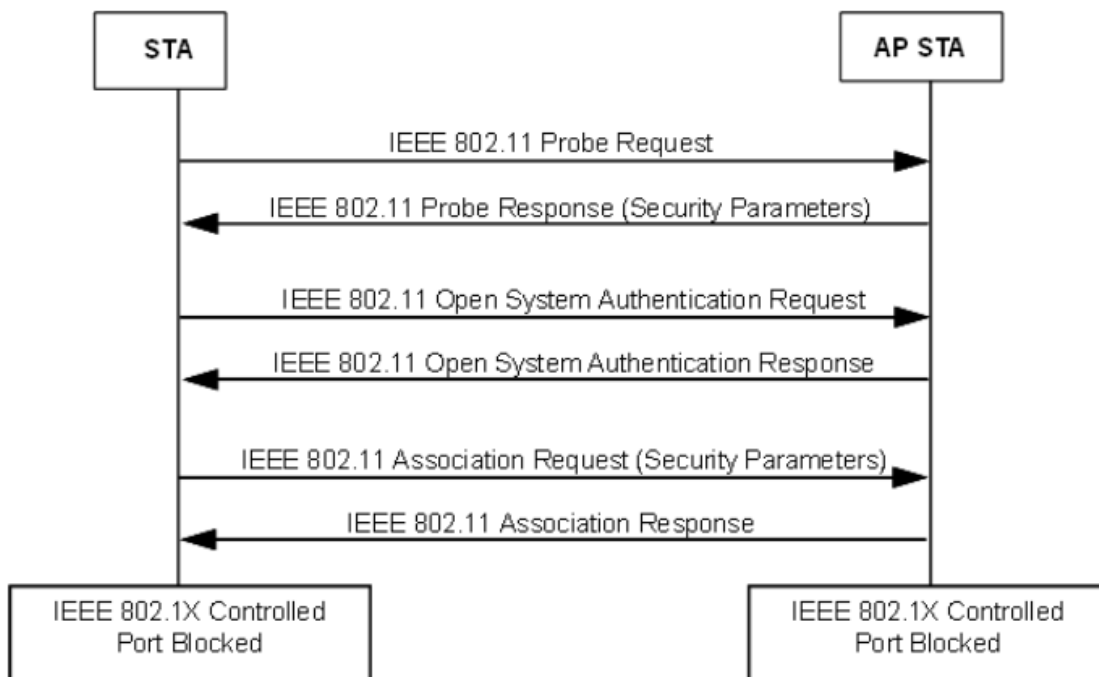

(E.g., IEEE 802.11i).

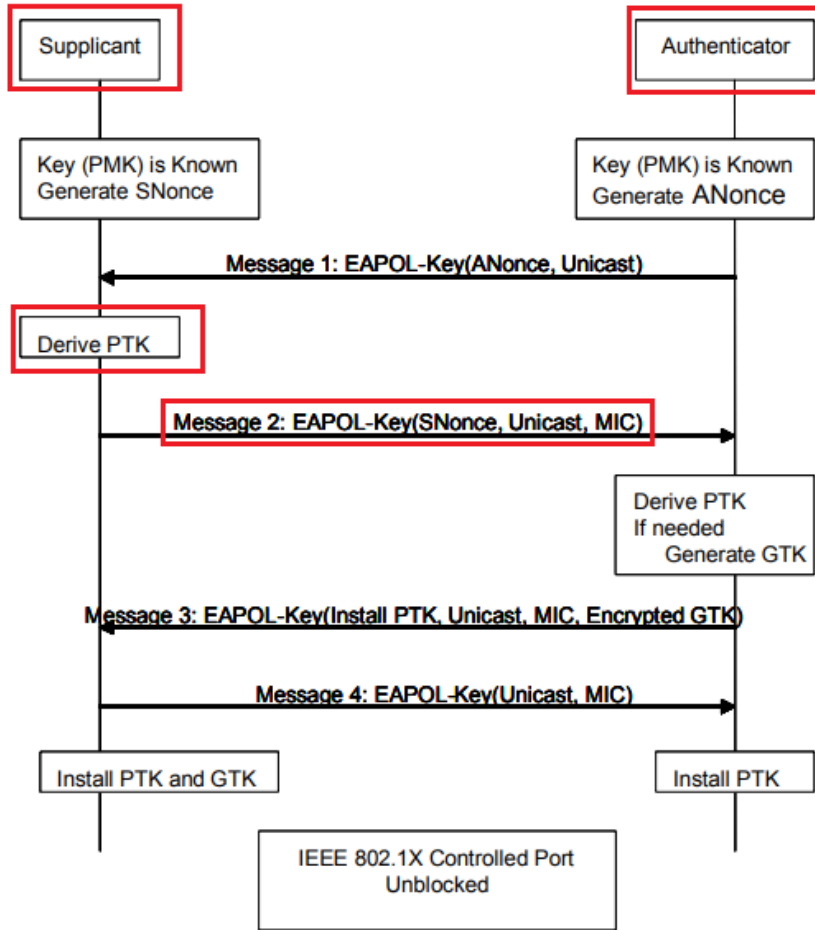

Descriptor Type – 1 octet	
Key Information – 2 octets	Key Length – 2 octets
Key Replay Counter – 8 octets	
Key Nonce – 32 octets	
EAPOL-Key IV – 16 octets	
Key RSC – 8 octets	
Reserved - 8 octets	
Key MIC – 16 octets	
Key Data Length – 2 octets	Key Data – n octets

Figure 43u—EAPOL-Key frame

(E.g., IEEE 802.11i).

3.97 pairwise transient key (PTK): A value that is derived from the pairwise master key (PMK), Authenticator address (AA), Supplicant address (SPA), Authenticator nonce (ANonce), and Supplicant nonce (SNonce) using the pseudo-random function (PRF) and that is split up into as many as five keys, i.e., temporal encryption key, two temporal message integrity code (MIC) keys, EAPOL-Key encryption key (KEK), EAPOL-Key confirmation key (KCK).

The pairwise key hierarchy utilizes PRF-384 or PRF-512 to derive session-specific keys from a PMK, as depicted in Figure 43s. The PMK shall be 256 bits. The pairwise key hierarchy takes a PMK and generates a PTK. The PTK is partitioned into KCK and KEK, and temporal keys used by the MAC to protect unicast communication between the Authenticator's and Supplicant's respective STAs. PTKs are used between a single Supplicant and a single Authenticator.

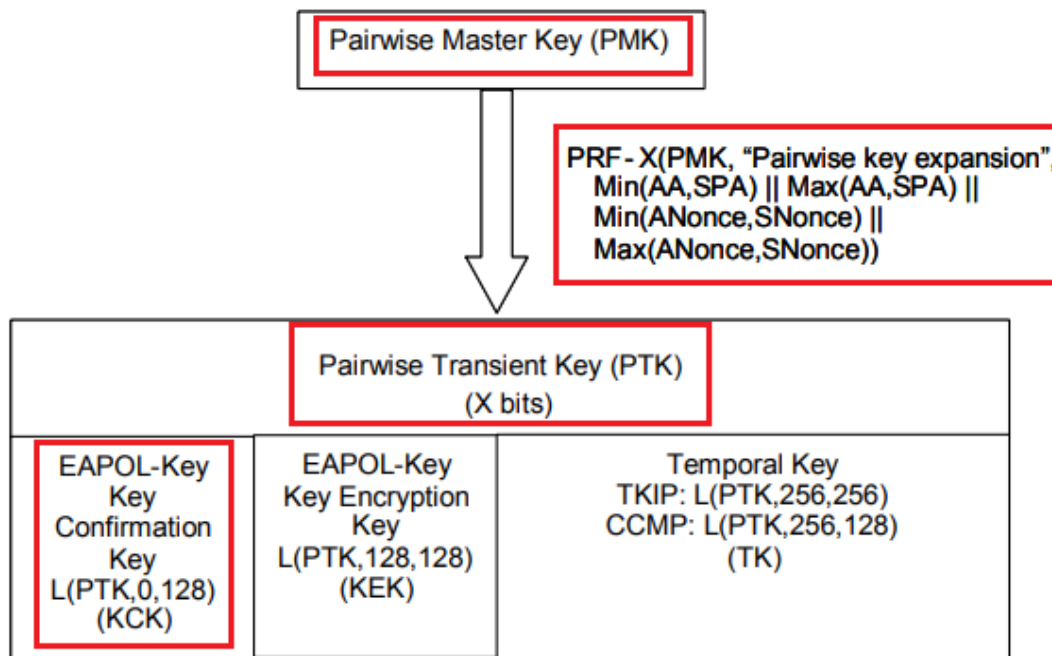

3.117 Supplicant address (SPA): The Supplicant's medium access control (MAC) address.

(E.g., IEEE 802.11i).

8.5.3.2 4-Way Handshake Message 2

Message 2 uses the following values for each of the EAPOL-Key frame fields:

Descriptor Type = N – see 8.5.2

Key Information:

Key Descriptor Version = 1 (RC4 encryption with HMAC-MD5) or 2 (NIST AES key wrap with HMAC-SHA1-128) – same as Message 1

Key Type = 1 (Pairwise) – same as Message 1

Install = 0

Key Ack = 0

Key MIC = 1

Secure = 0 – same as Message 1

Error = 0 – same as Message 1

Request = 0 – same as Message 1

Encrypted Key Data = 0

Reserved = 0 – unused by this protocol version

Key Length = 0

Key Replay Counter = n – to let the Authenticator know to which Message 1 this corresponds

Key Nonce = SNonce

EAPOL-Key IV = 0

Key RSC = 0

Key MIC = MIC(KCK, EAPOL) – MIC computed over the body of this EAPOL-Key frame with the Key MIC field first initialized to 0

Key Data Length = length in octets of included RSN information element

Key Data = included RSN information element – the sending STA's RSN information element

(*E.g.*, IEEE 802.11i).

26. Upon information and belief, the system utilized by the Accused Instrumentalities practices synchronously regenerating an authentication key (*e.g.*, temporal keys) at two network nodes (*e.g.*, the Accused Instrumentalities and an accessory device such as a Wi-Fi enabled smartphone, etc.) based upon node identifier information. As shown below, the accessory device sends its MAC address (*e.g.*, address) as well as a key value derived from the pre-shared key or pairwise master key (*e.g.*, initial authentication key) to the Accused Instrumentalities for authentication prior to connecting to the Wi-Fi network of the Accused Instrumentalities. The Accused Instrumentalities and the accessory device both regenerate temporal keys each time the devices get connected to each other. The Accused Instrumentalities and the accessory device, both

synchronously install temporal keys (i.e. a pairwise temporal key) with the help of a 4-way handshake message transfer having the node identifier information for establishing secured wireless communication.

8.4.8 RSNA key management in an ESS

When the IEEE 802.1X authentication completes successfully, this amendment assumes that the STA's IEEE 802.1X Supplicant and the IEEE 802.1X AS will share a secret, called a PMK. The AS transfers the PMK, within the AAA key, to the AP, using a technique that is outside the scope of this amendment; the derivation of the PMK from the MSK is EAP-method-specific. With the PMK in place, the AP initiates a key confirmation handshake with the STA. The key confirmation handshake sets the IEEE 802.1X state variable portValid (as described in IEEE P802.1X-REV) to TRUE.

The key confirmation handshake is implemented by the 4-Way Handshake. The purposes of the 4-Way Handshake are as follows:

- a) Confirm the existence of the PMK at the peer.
- b) Ensure that the security association keys are fresh.
- c) Synchronize the installation of temporal keys into the MAC.
- d) Transfer the GTK from the Authenticator to the Supplicant.

(E.g., IEEE 802.11i).

These are referred to as the temporal keys because they are recomputed every time a mobile device associates to the access point. The collection of all four keys together is referred to as the pairwise transient key (PTK). For RSN/TKIP and WPA, each of these keys must be 128 bits long so that the PTK is a total of 512 bits long.

The first two temporal keys sound familiar. They are the ones used to encrypt the data and protect it from modification. The second two we have not seen before. These are used to protect the communications between the access point and mobile device during the initial handshake.^[2] For the moment, just accept that these EAPOL keys are needed; we will discuss them again shortly.

^[2] And for various notifications after the handshake.

Because the temporal keys are recomputed each time a mobile device connects, there has to be something that changes when the computation is done; otherwise, you'd end up with the same temporal keys every time. This is called adding liveness to the keys, ensuring that old keys no longer work. Liveness is achieved by including a couple of special values called nonces in the computation. The value of the nonce is quite arbitrary except in one respect: a nonce value is never used twice^[3] with the same key. The word "nonce" can be thought of as "N ? once"?in other words, a value (N) only used once.^[4] They say lightning never strikes in the same place twice (which is not true) and similarly nonces never come up with the same value twice (which should be true by design).

(E.g., <http://etutorials.org/Networking/802.11+security.+wi-fi+protected+access+and+802.11i/Part+II+The+Design+of+Wi-Fi+Security/Chapter+10.+WPA+and+RSN+Key+Hierarchy/Pairwise+Key+Hierarchy/>).

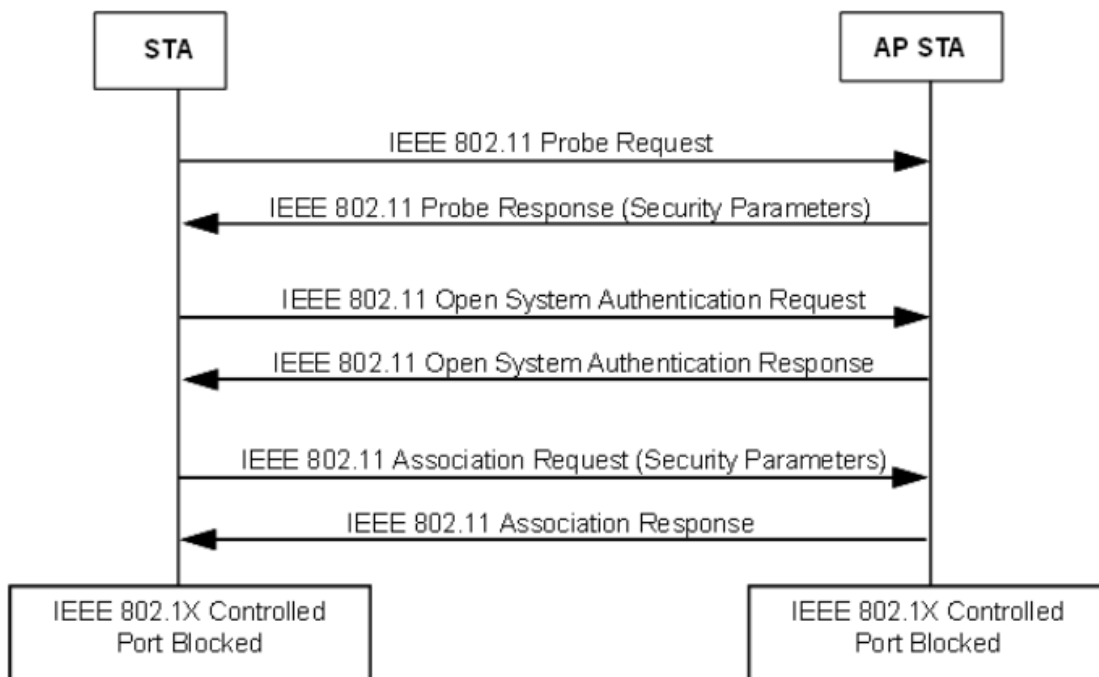

(E.g., IEEE 802.11i).

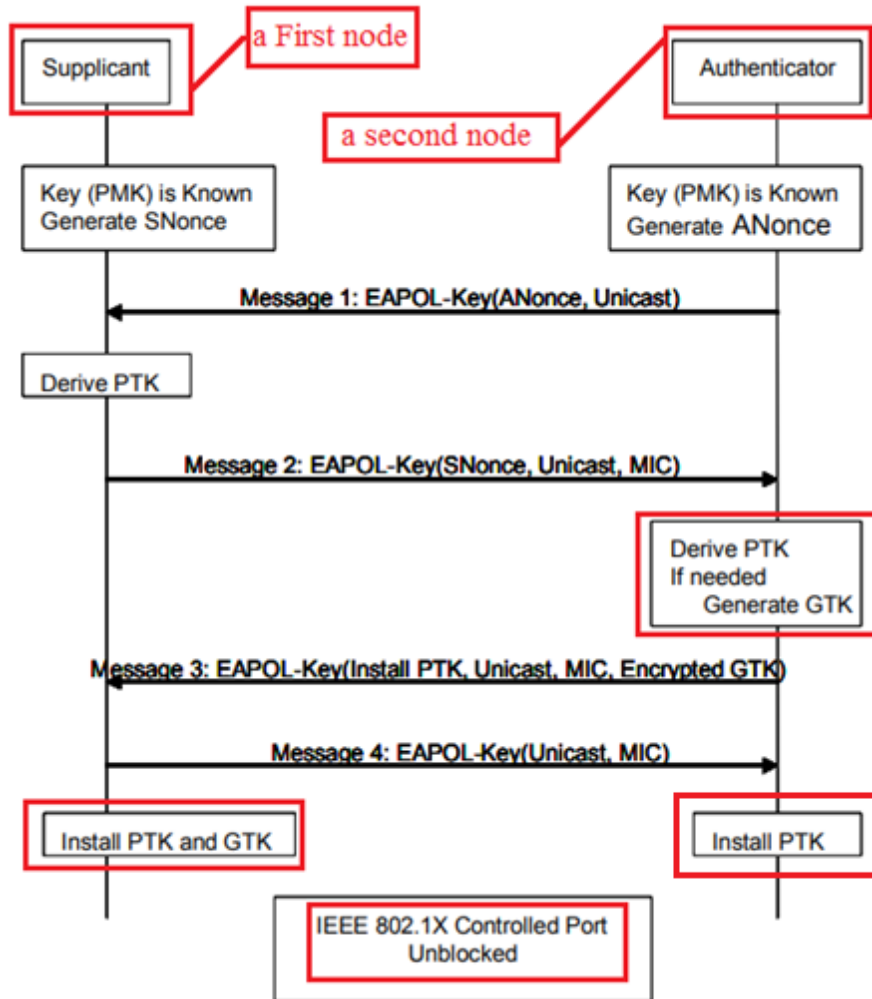

3.97 pairwise transient key (PTK): A value that is derived from the pairwise master key (PMK), Authenticator address (AA), Supplicant address (SPA), Authenticator nonce (ANonce), and Supplicant nonce (SNonce) using the pseudo-random function (PRF) and that is split up into as many as five keys, i.e., temporal encryption key, two temporal message integrity code (MIC) keys, EAPOL-Key encryption key (KEK), EAPOL-Key confirmation key (KCK).

(E.g., IEEE 802.11i).

The pairwise key hierarchy utilizes PRF-384 or PRF-512 to derive session-specific keys from a PMK, as depicted in Figure 43s. The PMK shall be 256 bits. The pairwise key hierarchy takes a PMK and generates a PTK. The PTK is partitioned into KCK and KEK, and temporal keys used by the MAC to protect unicast communication between the Authenticator's and Supplicant's respective STAs. PTKs are used between a single Supplicant and a single Authenticator.

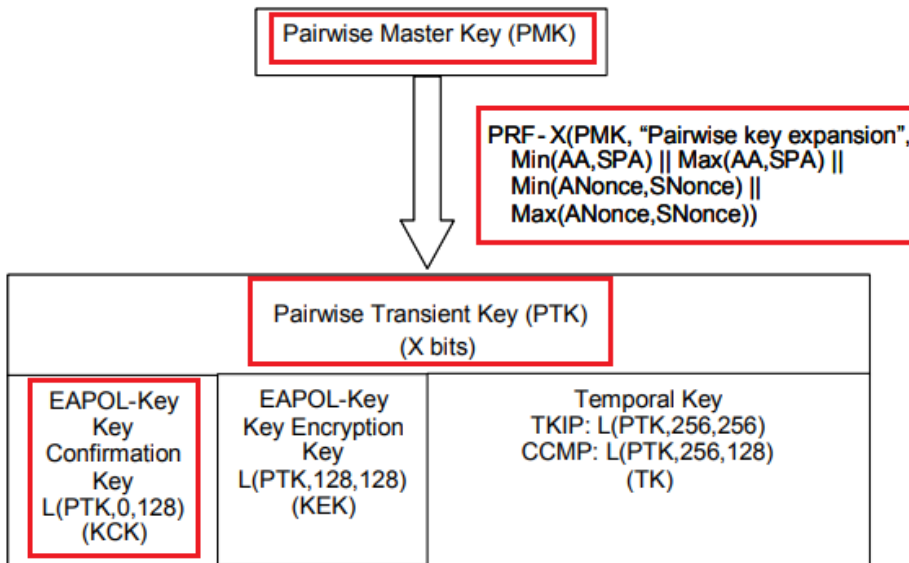

(E.g., IEEE 802.11i).

27. Defendant’s customers also infringe claim 1 of the ‘664 patent by using or performing the claimed method using the Accused Instrumentalities as described above. Furthermore, Defendant advertises, markets, and offers for sale the Accused Instrumentalities to its customers for use in a system in a manner that, as described above, infringes claim 1 of the ‘664 patent. Exemplary advertising and marketing material is cited above.

28. Plaintiff has been damaged as a result of Defendant’s infringing conduct. Defendant is thus liable to Plaintiff for damages in an amount that adequately compensates Plaintiff for such Defendant’s infringement of the ‘664 patent, *i.e.*, in an amount that by law cannot be less than would constitute a reasonable royalty for the use of the patented technology, together with interest and costs as fixed by this Court under 35 U.S.C. § 284.

29. On information and belief, Defendant has had at least constructive notice of the '664 patent by operation of law and, to the extent required, marking requirements have been complied with.

30. On information and belief, Defendant will continue its infringement of one or more claims of the '664 patent unless enjoined by the Court. Defendant's infringing conduct thus causes Plaintiff irreparable harm and will continue to cause such harm without the issuance of an injunction.

IV. JURY DEMAND

Plaintiff, under Rule 38 of the Federal Rules of Civil Procedure, requests a trial by jury of any issues so triable by right.

V. PRAYER FOR RELIEF

WHEREFORE, Plaintiff respectfully requests that the Court find in its favor and against Defendant, and that the Court grant Plaintiff the following relief:

- a. Judgment that one or more claims of United States Patent No. 7,233,664 have been infringed, either literally and/or under the doctrine of equivalents, by Defendant;
- b. Judgment that Defendant account for and pay to Plaintiff all damages to and costs incurred by Plaintiff because of Defendant's infringing activities and other conduct complained of herein;
- c. That Defendant be enjoined from future infringing activities;
- d. That Plaintiff be granted pre-judgment and post-judgment interest on the damages caused by Defendant's infringing activities and other conduct complained of herein; and
- e. That Plaintiff be granted such other and further relief as the Court may deem just and proper under the circumstances.

June 26, 2024

DIRECTION IP LAW

/s/ David R. Bennett

David R. Bennett

Direction IP Law

P.O. Box 14184

Chicago, IL 60614-0184

(312) 291-1667

dbennett@directionip.com

Attorneys for Plaintiff

Encryptawave Technologies LLC