

**IN THE UNITED STATES DISTRICT COURT
FOR THE EASTERN DISTRICT OF TEXAS
MARSHALL DIVISION**

LONGHORN AUTOMOTIVE GROUP LLC,

Plaintiff,

v.

HYUNDAI MOTOR COMPANY and KIA
CORPORATION,

Defendants.

Case No. 2:24-cv-

JURY TRIAL DEMANDED

COMPLAINT FOR PATENT INFRINGEMENT

Plaintiff Longhorn Automotive Group LLC (“LAG” or “Plaintiff”) for its Complaint for patent infringement against Defendants Hyundai Motor Company and Kia Corporation (collectively, “Hyundai” or “Defendants”) alleges as follows:

THE PARTIES

1. LAG is a limited liability company organized and existing under the laws of the State of Texas, with its principal place of business located at 104 E. Houston Street, Marshall, Texas 75670.

2. Upon information and belief, Defendant Hyundai Motor Company is a Korean corporation, with its principal place of business located at 12 Heolleung-ro Seocho-gu Seoul 06797, Republic of Korea. Upon information and belief, Hyundai Motor Company does business in Texas and in the Eastern District of Texas, directly or through intermediaries.

3. Upon information and belief, Defendant Kia Corporation is a Korean corporation, with its principal place of business located at 730-7 Mok-dong, Yangcheon-gu Seoul, Seoul, 07946

Republic of Korea. Upon information and belief, Defendant Kia Corporation does business in Texas and in the Eastern District of Texas, directly or through intermediaries.

JURISDICTION

4. This is an action for patent infringement arising under the patent laws of the United States, 35 U.S.C. §§ 1, *et seq.* This Court has jurisdiction over this action pursuant to 28 U.S.C. §§ 1331 and 1338(a).

5. This Court has personal jurisdiction over Defendants. Defendants regularly conduct business and have committed acts of patent infringement and/or have induced acts of patent infringement by others in this Judicial District and/or have contributed to patent infringement by others in this Judicial District, the State of Texas, and elsewhere in the United States.

6. Venue is proper in this Judicial District pursuant to 28 U.S.C. § 1391 because, among other things, Defendants are not residents in the United States, and thus may be sued in any judicial district pursuant to 28 U.S.C. § 1391(c)(3).

7. Defendants are subject to this Court's jurisdiction pursuant to due process and/or the Texas Long Arm Statute due at least to their substantial business in this State and Judicial District, including (a) at least part of its past infringing activities, (b) regularly doing or soliciting business in Texas, and/or (c) engaging in persistent conduct and/or deriving substantial revenue from goods and services provided to customers in Texas.

PATENTS-IN-SUIT

8. On August 19, 2014, the United States Patent and Trademark Office duly and legally issued U.S. Patent No. 8,810,803 (the "'803 Patent") entitled "Lens System". A true and

correct copy of the '803 Patent is available at:
<https://patentimages.storage.googleapis.com/b8/ee/03/9912346a786072/US8810803.pdf>.

9. On July 26, 2011, the United States Patent and Trademark Office duly and legally issued U.S. Patent No. 7,987,002 (the "'002 Patent") entitled "Arrangement for Distributed Measurement System for Measurement and Simulation in Distributed Control Systems". A true and correct copy of the '002 Patent is available at:
<https://patentimages.storage.googleapis.com/2e/7c/c3/eaf362f9a8faf3/US7987002.pdf>.

10. On April 7, 2009, the United States Patent and Trademark Office duly and legally issued U.S. Patent No. 7,513,238 (the "'238 Patent") entitled "Directly Injecting Internal Combustion Engine." A true and correct copy of the '238 Patent is available at:
<https://patentimages.storage.googleapis.com/23/6c/e0/5d3e6ec82760c9/US7513238.pdf>.

11. On September 11, 2012, the United States Patent and Trademark Office duly and legally issued U.S. Patent No. 8,265,353 (the "'353 Patent") entitled "Method of Reconstructing an Image Acquired Using Several Imagery Modes." A true and correct copy of the '353 Patent is available at:
<https://patentimages.storage.googleapis.com/c3/ee/14/9676306bcc9887/US8265353.pdf>.

12. On July 2, 2013, the United States Patent and Trademark Office duly and legally issued Reissued U.S. Patent No. RE44,331 (the '331 Patent") entitled "Vehicle Collision Detector". A true and correct copy of the '331 Patent is available at:
<https://patentimages.storage.googleapis.com/44/c0/3a/5548eb91a45bc8/USRE44331.pdf>.

13. On August 8, 2006, the United States Patent and Trademark Office duly and legally issued U.S. Patent No. 7,089,101 (the "'101 Patent") entitled "Method for Assisting a Driver When

Performing Driving Maneuvers”. A true and correct copy of the ’101 Patent is available at: <https://patentimages.storage.googleapis.com/5f/6d/df/4b65ee15a8037e/US7089101.pdf>.

14. LAG is the sole and exclusive owner of all right, title, and interest in the ’803 Patent, the ’002 Patent, the ’238 Patent, the ’353 Patent, the ’331 Patent, and the ’101 Patent, (collectively, the “Patents-in-Suit”) and holds the exclusive right to take all actions necessary to enforce its rights to the Patents-in-Suit, including the filing of this patent infringement lawsuit. LAG also has the right to recover all damages for the past, present, and future infringement of the Patents-in-Suit and to seek injunctive relief as appropriate under the law.

FACTUAL ALLEGATIONS

15. The ’803 Patent generally relates to a plurality of lenses is used for focusing and projecting the light in plurality of directions. Such patterns include those generated by systems from an emitted light source. These patterns may be analyzed by computers to identify and determine aspects of the light patterns. The technology described in the ’803 Patent was developed by inventor Matt Bell. For example, this technology is implemented in Defendants’ headlight systems included in commercial and personal vehicles, in all trims and configurations, such as the Hyundai Venue, Hyundai Kona, Hyundai Kona Electric, Hyundai Kona N, Hyundai Santa Cruz, Hyundai Tucson, Hyundai Tucson Hybrid, Hyundai Plug-in Hybrid, Hyundai Santa Fe, Hyundai Santa Fe Hybrid, Hyundai Santa Fe Plug-in Hybrid, Hyundai Palisade, Hyundai Ioniq 5, Hyundai Fuel Cell, Hyundai Ioniq 6, Hyundai Elantra, Hyundai Elantra Hybrid, Hyundai Elantra N, Hyundai Sonata, Hyundai Sonata N, Hyundai Sonata Hybrid, Hyundai Veloster, Hyundai Kona, Hyundai Creta, Kia Soul, Kia Seltos, Kia Sportage, Kia Sorento, Kia Carnival MPV, Kia Telluride, Kia Niro, Kia Sportage Hybrid, Kia Miro Plug-in Hybrid, Kia Sorento Hybrid, Hyundai Accent, Kia Sportage Plug-in Hybrid, Kia Niro EV, Kia EV6, Kia Sorento Plug-in Hybrid, Kia Rio, Kia

Rio 5-Door, Kia Forte, Kia K5, Kia Stinger, Genesis GV60, Genesis GV70, Genesis Electrified GV70, Genesis GV80, Genesis G70, Genesis G80, Genesis, Electrified G80, Genesis G90, and Genesis GV60, among other automotive vehicles (collectively, the “Accused Vehicles”).

16. The '002 Patent generally relates to a monitoring system with plurality of monitoring units communicating with a first interface in a first protocol which in turn is connected to a distributed control systems using a second protocol. The technology described in the '002 Patent was developed by inventor Lars-Berno Fredriksson. For example, this technology is implemented in Hyundai Bluelink technology, and all previous versions and iterations, included with commercial and personal vehicles, in all trims and configurations, including the Accused Vehicles.

17. The '238 Patent generally relates to novel direct injection in internal combustion engines where the shapes of the piston allow for early or late injection to optimize the direct injection. The technology described in the '238 Patent was developed by inventors Ruediger Pfaff, Martin Schnabel, and Joachim Suess at DaimlerChrysler AG. For example, this technology is implemented in Hyundai and Kia internal combustion engines included in commercial and personal vehicles, in all trims and configurations, such as the Gamma 1.6 Turbo GD Engine, including the Accused Vehicles.

18. The '353 Patent generally relates to measuring a mobile object using a plurality of imaging techniques in synchronization to provide video images of an object's state. The technology described in the '353 Patent was developed by Stéphane Bonnet and Pierre Grangeat. For example, this technology is implemented in Defendants' driver assistance systems, including Hyundai's SmartSense, and all previous versions and iterations, in all trims and configurations, including the Accused Vehicles.

19. The '331 Patent generally relates to a system and method for preventing collisions in vehicles. The technology described in the '331 Patent was developed by Göran Sjönell. For example, this technology is implemented in Hyundai-Kia's driver assistance systems, including Hyundai's SmartSense, and all previous versions and iterations, in all trims and configurations, including the Accused Vehicles.

20. The '101 Patent generally relates to a method for assisting a driver of a vehicle when performing driving maneuvers. The technology described in the '101 Patent was developed by Eckart Fischer, Helmut Keller, Jens Koehnlein, Jakob Seiler, Andreas Spieker, David Ulmer, and Andy Yap at DaimlerChrysler AG. For example, this technology is implemented in Hyundai-Kia's driver assistance systems, including Hyundai's SmartSense, and all previous versions and iterations, in all trims and configurations, including the Accused Vehicles.

21. Hyundai has infringed the Patents-in-Suit and is continuing to infringe '803 Patent, the 238 Patent, the '002 Patent, the '353 Patent, and the '331 Patent by one or more of making, using, selling, offering to sell, and/or importing, and by actively inducing others to make, use, sell, offer to sell, and/or importing commercial and personal vehicles, which are used or tested by Hyundai and its direct or indirect customers or users in the United States.

COUNT I
(Infringement of the '803 Patent)

22. Paragraphs 1 through 21 are incorporated by reference as if fully set forth herein.

23. LAG has not licensed or otherwise authorized Defendants to make, use, offer for sale, sell, or import any products that embody the inventions of the '803 Patent.

24. Defendants have and continue to directly infringe the '803 Patent, either literally or under the doctrine of equivalents, without authority and in violation of 35 U.S.C. § 271, by one or more of making, using, offering to sell, selling, and/or importing into the United States products

that satisfy each and every limitation of one or more claims of the '803 Patent. Such products include, but are not limited to, the Genesis G80, equipped with Intelligent Front-Sighting System (IFS) with Matrix Beam LED headlights, among other vehicles.

25. For example, Defendants have and continue to directly infringe at least claim 15 of the '803 Patent by making, using, offering to sell, selling, and/or importing the Accused Vehicles into the United States that include Matrix Beam LED headlights, or equivalent thereof, such as the Genesis G80, among other products.

26. For example, the Genesis G80 comprises a system for projecting a pattern of light.

The advertisement features a dark blue Genesis G80 sedan parked on a city street at night. The car's rear is visible, showing the license plate '129H 3736'. The background is a blurred city scene with streetlights and buildings. The text is arranged as follows:

- Top left: "G80 SAFETY" in small letters, followed by "INTELLIGENT DRIVING" in large, bold, white letters. Below that, in smaller white text: "GENESIS G80'S CUTTING-EDGE TECHNOLOGY REACHES NEW STANDARDS OF SAFETY".
- Bottom left: "Book a Test Drive >" in small white letters.
- Top right: "SAFETY FEATURES" in orange letters.
- Middle right: "INTELLIGENT FRONT LIGHTING SYSTEM" in large, bold, black letters.
- Bottom right: A paragraph of text: "It allows the driver to travel in the vehicle with an always-on high beam without risk of glaring in vision of oncoming traffic or any preceding vehicles. This function is achieved using LEDs with individual electronic control which are turned up or dimmed down as required."

¹ <https://www.hyundaimotorgroup.com/story/CONT0000000000003757>.

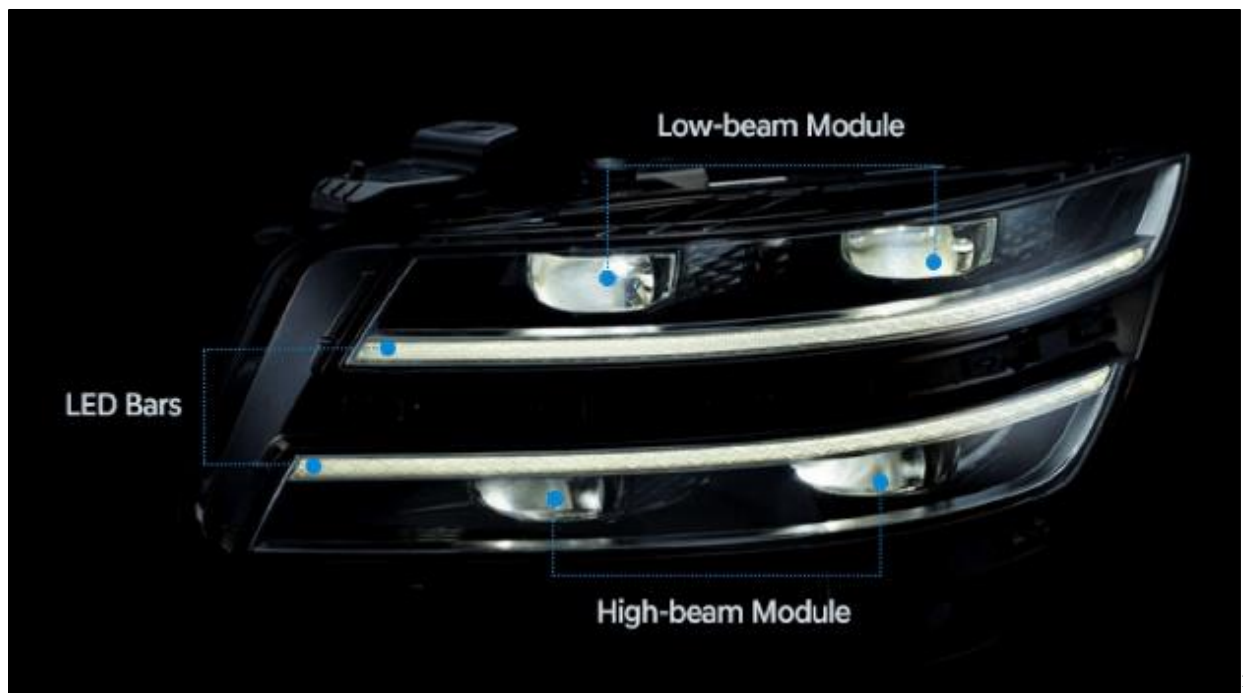

2

The IFS technology was applied to the high-beam module encased in the lower lamps. High-beams are often considered a double-edged sword: while they ensure the visibility of the driver who uses them, the added visibility often comes at a sacrifice of the driver from the oncoming car, who may be blinded by the powerful stream of light. The IFS, though, comes with the partial light control capability that prevents such dazzling effects from happening, ensuring added visibility without inconveniencing other drivers.

Each high-beam module contains a Matrix Beam LED, which aligns a whopping 8 LEDs in a row and therefore can offer high, concentrated visibility. As each headlamp contains two high-beam modules, a total of 32 LEDs collaborate to light the front. Thanks to this diversification of light sources, the IFS can precisely control the direction and the intensity of light beams.

3

² *Id.*

³ *Id.*

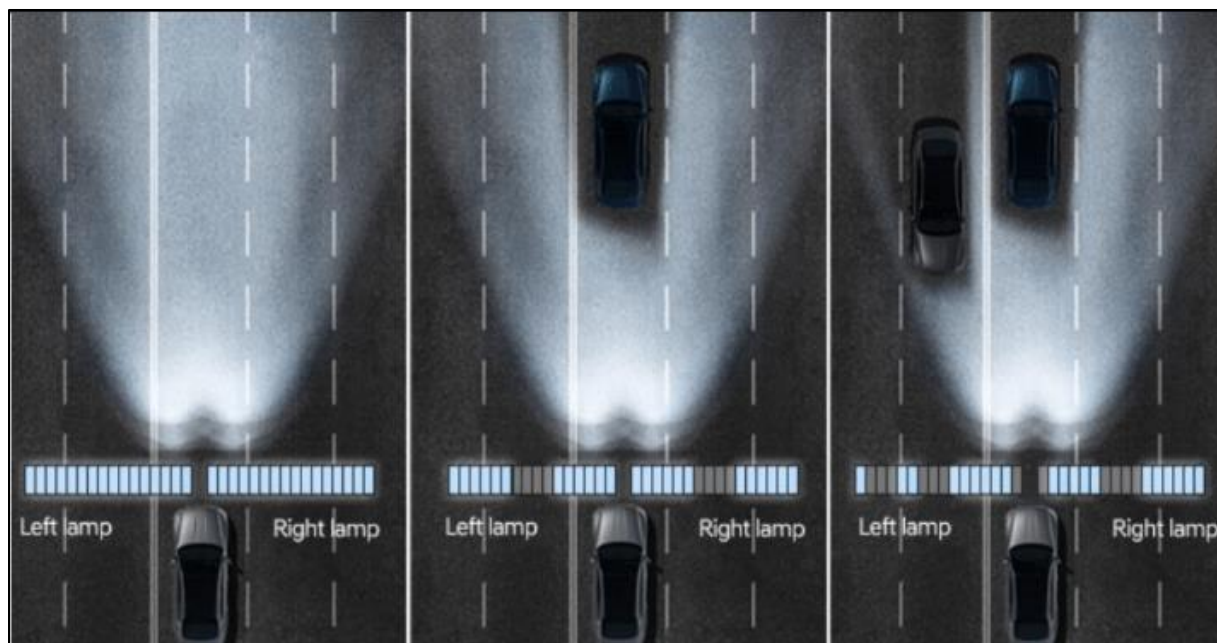

27. The Genesis G80 comprises a light source (e.g., Matrix Beam LED headlights) including a plurality of emitters configured to emit light:



⁴ *Id.*

⁵ *Id.*

Each high-beam module contains a Matrix Beam LED, which aligns a whopping 8 LEDs in a row and therefore can offer high, concentrated visibility. As each headlamp contains two high-beam modules, a total of 32 LEDs collaborate to light the front. Thanks to this diversification of light sources, the IFS can precisely control the direction and the intensity of light beams.

6

28. The Genesis G80 comprises a cluster of lenses (e.g., freeform lenses of the high beam module), each lens included in the cluster of lenses being configured to receive the emitted light from each of the plurality of emitters (e.g., each of the multiple LEDs):

The light waves generated by the Matrix Beam LED are subjected through two special lenses that control the beam patterns. The optic lens positioned directly in front of the light source creates rectangular matrix beam patterns; these patterns then go through the freeform lens, which refracts and/or diffuses the pattern. The powerful lights from the IFS's efficient LEDs would be in vain if not for the assistance from these optical structures.

7

Each high-beam module contains a Matrix Beam LED, which aligns a whopping 8 LEDs in a row and therefore can offer high, concentrated visibility. As each headlamp contains two high-beam modules, a total of 32 LEDs collaborate to light the front. Thanks to this diversification of light sources, the IFS can precisely control the direction and the intensity of light beams.

8

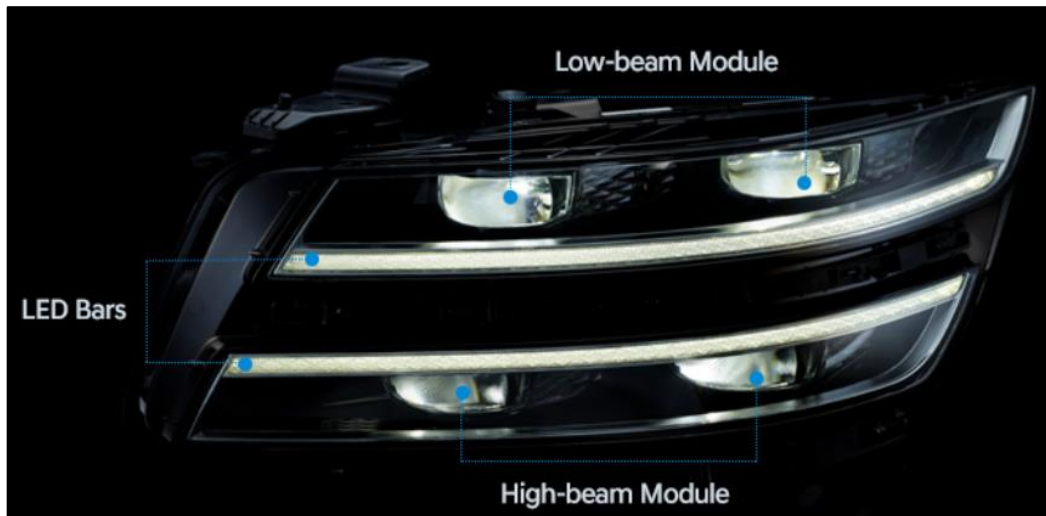

9

⁶ *Id.*

⁷ *Id.*

⁸ *Id.*

⁹ *Id.*



29. The Genesis G80 comprises a condenser lens (e.g., the optics lens) located between said light source (e.g., the Matric Beam LED) and said cluster of lenses (e.g. the freeform lenses of both the lamps of the high beam modules), the condenser lens concentrating light from each of the plurality of emitters towards a center of the cluster of lenses:

¹⁰ *Id.*

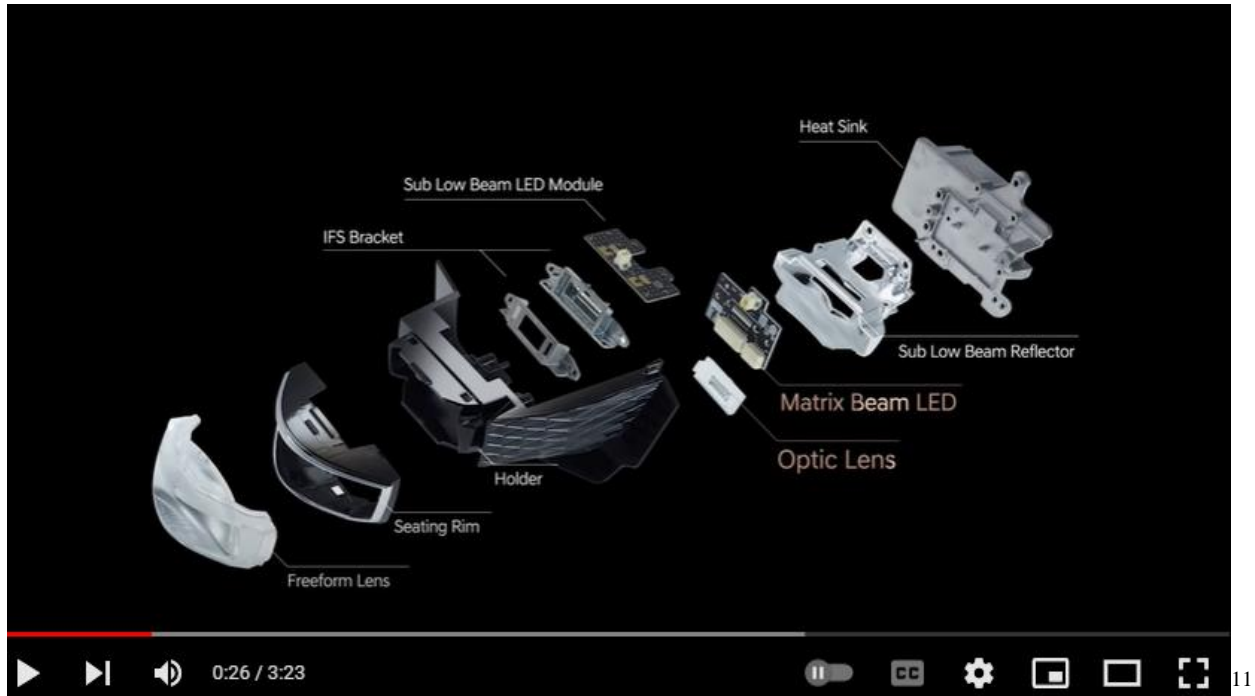

Each high-beam module contains a Matrix Beam LED, which aligns a whopping 8 LEDs in a row and therefore can offer high, concentrated visibility. As each headlamp contains two high-beam modules, a total of 32 LEDs collaborate to light the front. Thanks to this diversification of light sources, the IFS can precisely control the direction and the intensity of light beams.

12

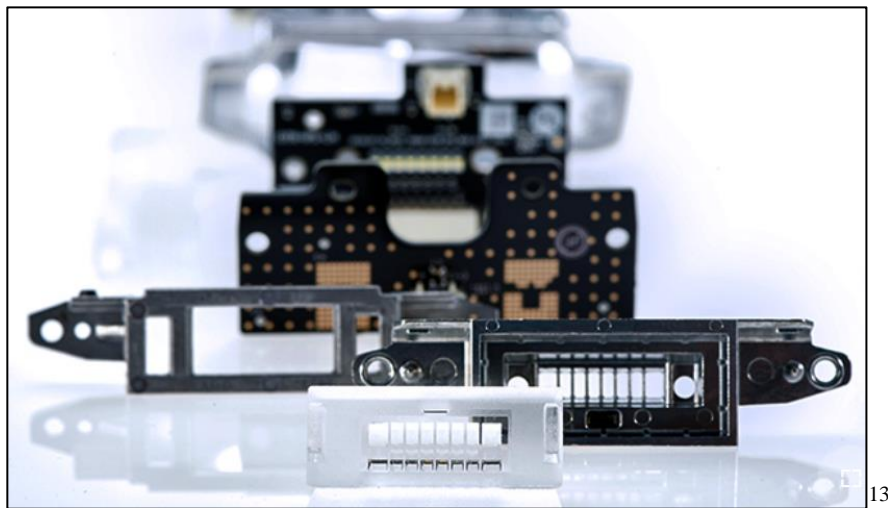

30. Defendants have and continue to indirectly infringe one or more claims of the '803

¹¹ <https://www.youtube.com/watch?v=fGwt2uA7MIM&t=1s>.

¹² <https://www.hyundaimotorgroup.com/story/CONT0000000000003757>.

¹³ *Id.*

Patent by knowingly and intentionally inducing others, including Hyundai customers and end-users, to directly infringe, either literally or under the doctrine of equivalents, by making, using, offering to sell, selling, and/or importing into the United States products that include infringing technology.

31. Defendants, with knowledge that these products, or the use thereof, infringe the '803 Patent at least as of the date of this Complaint, knowingly and intentionally induced, and continue to knowingly and intentionally induce, direct infringement of the '803 Patent by providing these products to customers and end-users for use in an infringing manner. Alternatively, on information and belief, Defendants have adopted a policy of not reviewing the patents of others, including specifically those related to Defendants' specific industry, thereby remaining willfully blind to the Patents-in-Suit at least as early as the issuance of the Patents-in-Suit.

32. Defendants have and continue to induce infringement by others, including customers and end-users, with the intent to cause infringing acts by others or, in the alternative, with the belief that there was a high probability that others, including end-users, infringe the '803 Patent, but while remaining willfully blind to the infringement. Defendants have and continue to induce infringement by their customers and end-users by supplying them with instructions on how to operate the infringing technology in an infringing manner, while also making publicly available information on the infringing technology via Defendants' website, product literature and packaging, and other publications.¹⁴

33. LAG has suffered damages as a result of Defendants' direct and indirect

¹⁴ See, e.g., Genesis Owner's Manuals, Quick Reference Guides, and other materials, available at: <https://owners.genesis.com/us/en/resources/manuals-warranties.html>.

infringement of the '803 Patent in an amount to be proved at trial.

34. LAG has suffered, and will continue to suffer, irreparable harm as a result of Defendants' infringement of the '803 Patent, for which there is no adequate remedy at law, unless Defendants' infringement is enjoined by this Court.

COUNT II
(Infringement of the '002 Patent)

35. Paragraphs 1 through 21 are incorporated by reference as if fully set forth herein.

36. LAG has not licensed or otherwise authorized Defendants to make, use, offer for sale, sell, or import any products that embody the inventions of the '002 Patent.

37. Defendants have and continue to infringe the '002 Patent, either literally or under the doctrine of equivalents, without authority and in violation of 35 U.S.C. § 271, by one or more of making, using, offering to sell, selling, and/or importing into the United States products that satisfy each and every limitation of one or more claims of the '002 Patent. Such products include, but are not limited to, the Accused Vehicles equipped with Bluelink technology, or the equivalent thereto, included in commercial and personal vehicles, in all trims and configurations.

38. For example, Defendants have and continue to directly infringe at least claim 15 of the '002 Patent by making, using, offering to sell, selling, and/or importing into the United States products that include the Bluelink system, such as the Hyundai Sonata, among other products.

39. The Hyundai Sonata comprises a monitoring system. The Hyundai Sonata includes Bluelink technology, which provides a system for remote monitoring and control services for Hyundai vehicle owners, including features like remote door lock/unlock, remote climate control, remote horn, and light control, and many more including diagnostic information:



15

¹⁵ <https://www.hyundaiusa.com/us/en/blue-link>.



Bluelink[®] is a dynamic, telematics technology that allows Hyundai vehicles to send—and receive—important and useful information. The system uses an enhanced cellular network, with automatic roaming, that optimizes connections and prioritizes emergency requests. In your vehicle, Bluelink uses voice-response technology, with the addition of GPS and a live assistance team for selected needs.

With Bluelink you get...

- Automatic emergency assistance, in the unfortunate event of a collision.
- The convenience of Destination Search by Voice, as well as the ability to remotely operate various vehicle features.
- The peace of mind that comes with in-vehicle, on-demand diagnostics, and more...

An available smart phone mobile app gives you direct access to selected Remote features such as Remote Start with Climate Control* and Remote Door Lock/Unlock.

16

Remote

- | | | |
|--|---|--|
| <ul style="list-style-type: none"> • Remote Service: <ul style="list-style-type: none"> - Remote Door Lock/Unlock - Remote Horn/Lights - Remote Start with Climate Control* - Car Finder** | <ul style="list-style-type: none"> • Vehicle Safeguard: <ul style="list-style-type: none"> - Stolen Vehicle Recovery - Stolen Vehicle - Vehicle Immobilization - Alarm Notification - Panic Notification | <ul style="list-style-type: none"> • Vehicle Safeguard Alert***: <ul style="list-style-type: none"> - Valet Alert - Geo-Fence - Speed Alert - Curfew Alert |
|--|---|--|

17

¹⁶ <https://owners.hyundaiusa.com/content/dam/hyundai/us/myhyundai/manuals/factory-warranty/2022/Bluelink-User-Manual.pdf>.

¹⁷ *Id.*

40. The Hyundai Sonata comprises a plurality of monitoring units (e.g., a mobile device with the MyHyundai App along with the Hyundai Bluelink Server) configured to communicate with at least one interface unit (e.g., the telematics control unit) using a first protocol (e.g., a cellular network), wherein the at least one interface unit is communicably connected to a distributed control system (e.g., the vehicle's electronic control modules such as Tire Pressure measuring Sensors (TPMS)), and the at least one interface unit is further configured to receive data values from the distributed control system using a second protocol (e.g., the CAN bus):



Bluelink[®] is a dynamic, telematics technology that allows Hyundai vehicles to send—and receive—important and useful information. The system uses an enhanced cellular network, with automatic roaming, that optimizes connections and prioritizes emergency requests. In your vehicle, Bluelink uses voice-response technology, with the addition of GPS and a live assistance team for selected needs.

With Bluelink you get...

- Automatic emergency assistance, in the unfortunate event of a collision.
- The convenience of Destination Search by Voice, as well as the ability to remotely operate various vehicle features.
- The peace of mind that comes with in-vehicle, on-demand diagnostics, and more...

An available smart phone mobile app gives you direct access to selected Remote features such as Remote Start with Climate Control* and Remote Door Lock/Unlock.

18

¹⁸ <https://owners.hyundaiusa.com/content/dam/hyundai/us/myhyundai/manuals/factory-warranty/2022/Bluelink-User-Manual.pdf>.

Remote		
• Remote Service:	• Vehicle Safeguard:	• Vehicle Safeguard Alert***:
- Remote Door Lock/Unlock	- Stolen Vehicle Recovery	- Valet Alert
- Remote Horn/Lights	- Stolen Vehicle	- Geo-Fence
- Remote Start with Climate Control*	- Vehicle Immobilization	- Speed Alert
- Car Finder**	- Alarm Notification	- Curfew Alert
	- Panic Notification	

19



20

¹⁹ *Id.*

²⁰ <https://www.youtube.com/watch?v=1fmGag8Nq48>.



BlueLink works with your devices. ⓘ

- BlueLink for iPhone® - OS 13.6 and above
- BlueLink for Apple Watch® - OS 2.0 and above
- Amazon Alexa
- Android™ smartphones - OS 12 and above
- Smartwatches powered with Wear OS by Google™ - OS 7.0 and above
- Tizen smartwatches - OS version 2.3 and above

21



For Remote Start Using BlueLink® to Work

The vehicle must have been started using ignition in last 4 days.
The mobile device and vehicle must have cellular reception.

HYUNDAI

2:05 / 2:45

Remote Start using Smart Key or Digital Key do not require cellular service.

22

²¹ <https://www.hyundaiusa.com/us/en/blue-link>.

²² <https://www.youtube.com/watch?v=Z6UaZSZAOA4&t=2s>.

You can change the data network settings, including Bluelink and Wi-Fi Hotspot.

1 On the All Menus screen, press **Setup** ► **Data/Network**.

The Data/Network Settings screen appears.



23

Configuring the Wi-Fi settings (if equipped)

You can change the Wi-Fi connection settings for wireless phone projection.

Depending on the vehicle model or specifications, displayed screens and available options may vary.

On the Home screen, press **All Menus** ► **Setup** ► **Wi-Fi** and select an option to change.

24

²³http://webmanual.hyundai.com/STD_GEN5W/AVNT/USA/English/010_Settings_datanetwork_2.html.

²⁴ http://webmanual.hyundai.com/DA_GEN2_V/AV/USA/English/010_Settings_wifi.html.

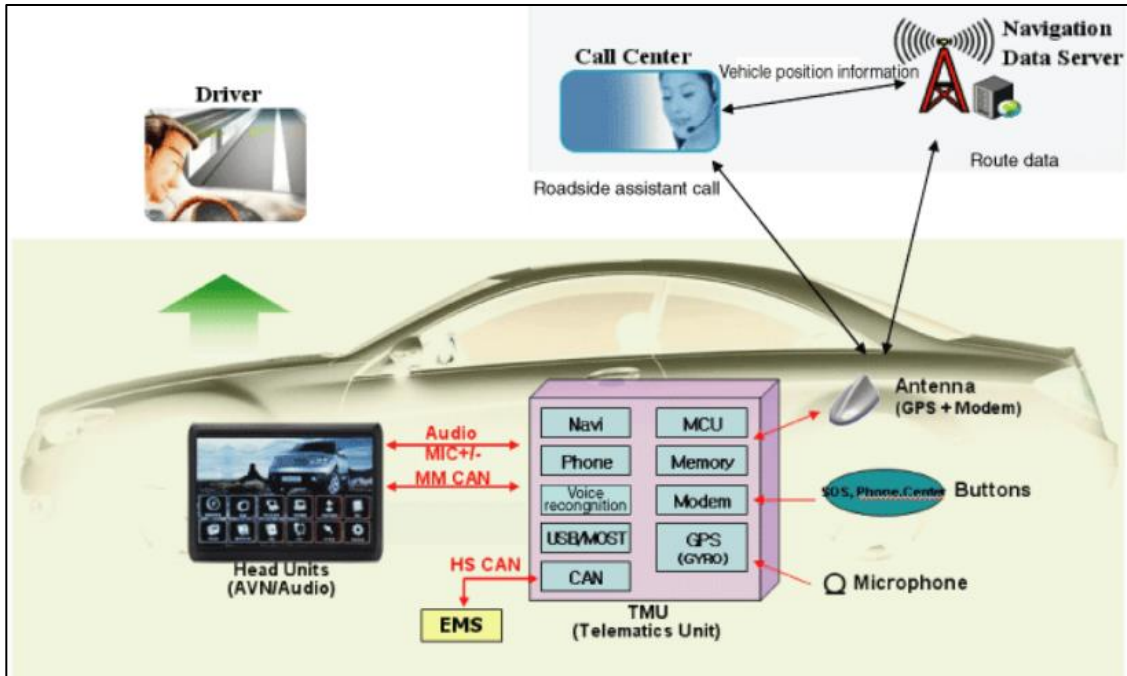

25

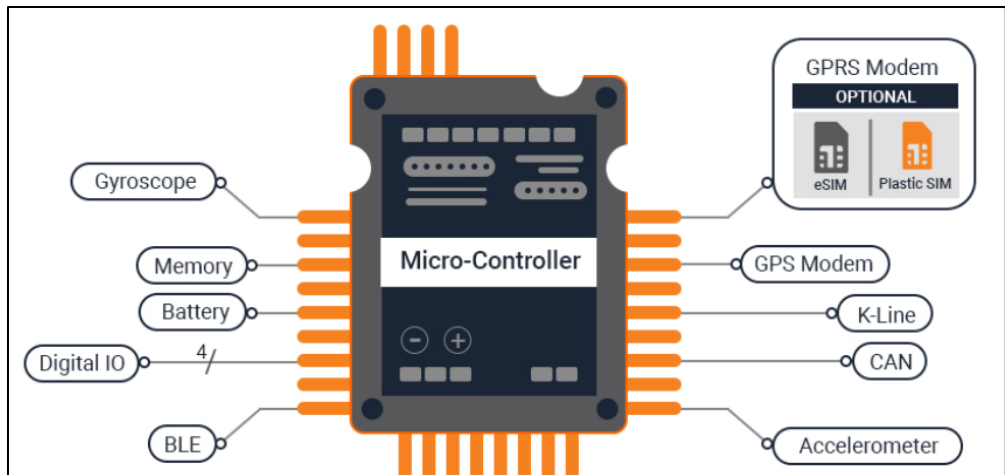

²⁵ https://www.hgmanual.com/description_and_operation-1226.html.

- A **CAN Bus** module that manages all the communication with the vehicle ECUs. Many of the commercially available telematics devices also support OBD II, MOST, LIN interfaces. The TCU communicates with the vehicle ECUs through CAN bus and fetches crucial information such as engine performance, vehicle speed, data from the Tire Pressure measuring Sensors, etc. A telematics system may also use K/Line bus to alert the user about theft (by notifying the user if the vehicle is switched on by anyone), or to enable remote locking and unlocking of the vehicle.

26

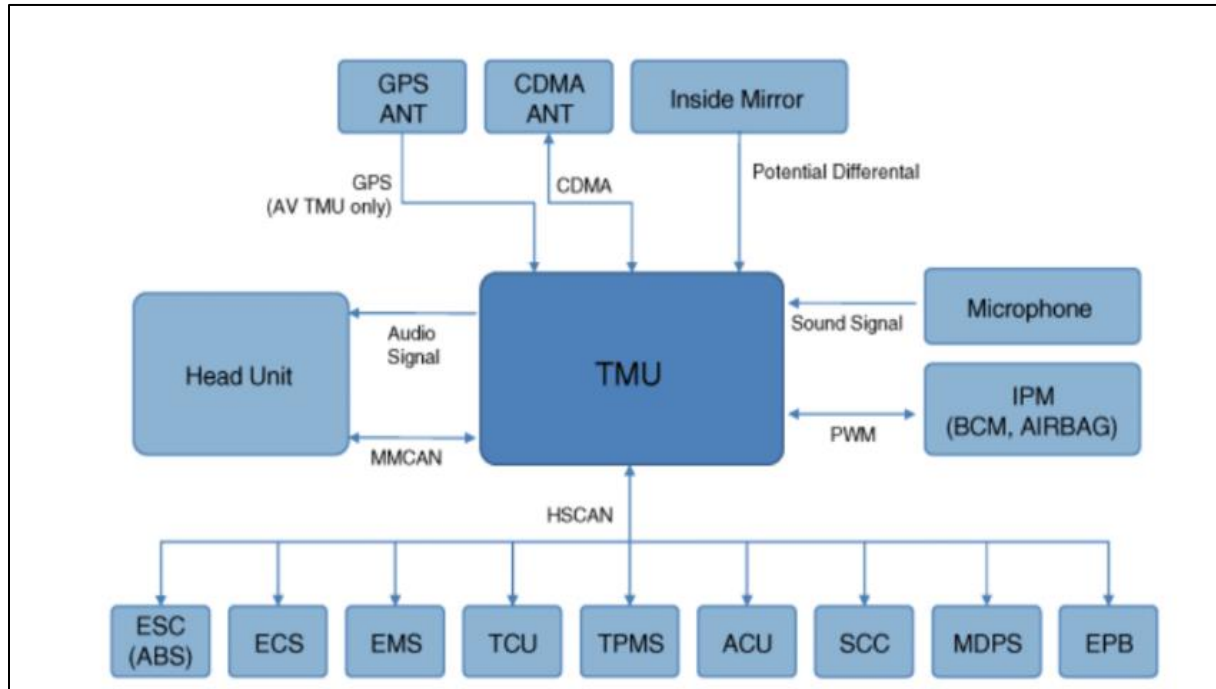

27

41. The Hyundai Sonata comprises a plurality of monitoring units wherein the plurality of monitoring units comprises at least one complex monitoring unit (e.g., the Hyundai Bluelink Server Platform) and at least one basic monitoring unit (e.g., a mobile device running the My Hyundai App with Bluelink Remote Service):

²⁶ <https://www.embitel.com/blog/embedded-blog/tech-behind-telematics-explained-how-does-a-vehicle-telematics-solution-work>.

²⁷ *Id.*

Blue Link® Mobile App Highlights

- Completely redesigned interface and navigation
- Swipe gestures allow quick access to core features
- Remotely access many Blue Link® features found on MyHyundai.com
 - Manage multiple Blue-Link-enrolled vehicles
- Remotely control vehicle functions: Door lock/unlock, horn & lights, lights-only and remote vehicle start (not available on all models)
 - Search, save and send POIs to vehicles for in-car navigation
- Innovative new features: car finder, parking meter/timer and vehicle diagnostics
 - Remotely manage Blue Link alerts and notifications

REMOTE ACCESS FEATURES

Blue Link® Essentials subscribers can access a number of key vehicle functions remotely from the mobile application without the need to be in the proximity of the vehicle. Remote Door Lock or unlock allows for remote control and convenience from virtually anywhere. Remote Horn & Lights allows the subscriber to remotely activate the horn and lights. Remote Lights allows subscriber to remotely activate the vehicle lights only. Remote Vehicle Start, which has been expanded to include more Hyundai models, allows the subscriber to remotely start their vehicle, an especially convenient feature in cold states during winter months. Vehicles equipped with push-button start and automatic or dual-clutch transmissions are supported for Remote Vehicle Start. For added security, all remote access features require the vehicle PIN to be entered prior to the command being sent.

28

42. The Hyundai Sonata comprises a plurality of monitoring units wherein the at least one complex monitoring unit (e.g., the Hyundai Bluelink server) is configured to receive a plurality of data values from the at least one interface unit using the first protocol (e.g., a cellular network) and to generate programmatic instructions (e.g., remote engine start) for the at least one basic monitoring unit (e.g., a mobile device running the My Hyundai App with Bluelink Remote Service):

²⁸ <https://www.hyundainews.com/en-us/releases/2256>.

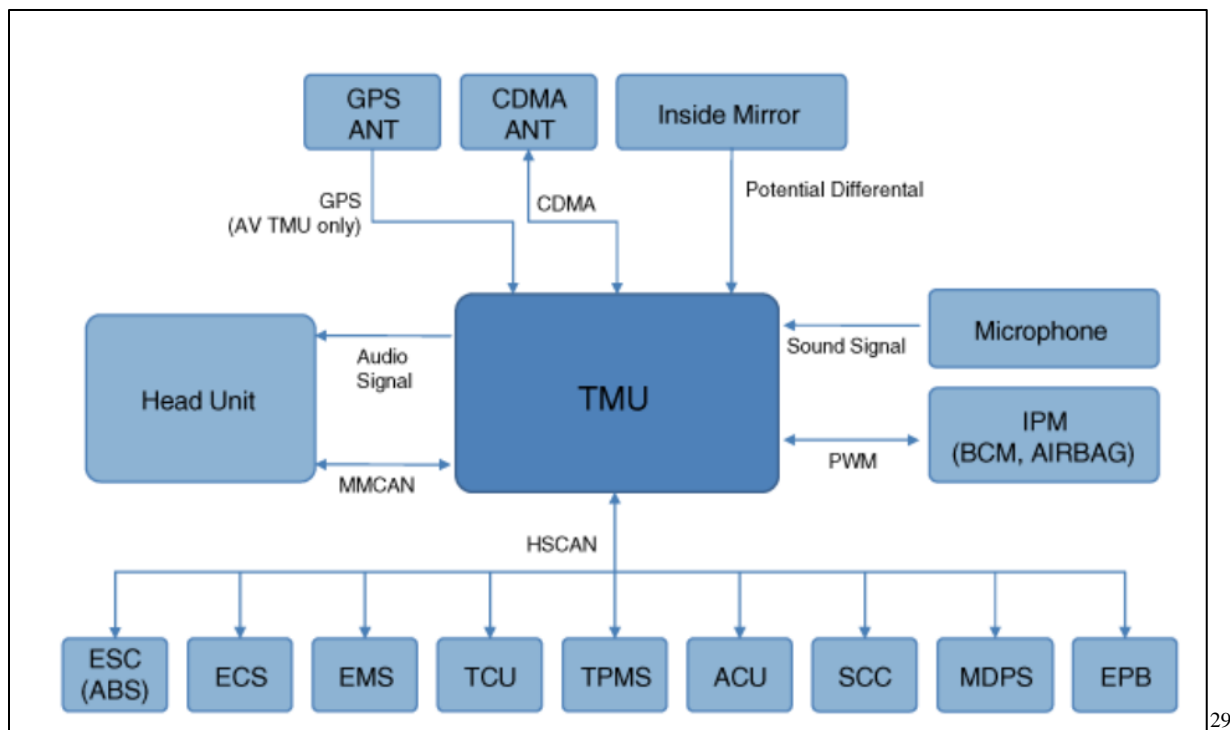

29

To Activate Remote Start with Climate Control

- **By Mobile App:** Select Remote features and REMOTE START.
 - Enter your Bluelink PIN.
 - Set engine duration and temperature control settings, if desired.
 - The engine start command will be sent to your vehicle.
- **By website:** Log on to www.MyHyundai.com, select Bluelink.
 - Select Remote Start.
 - Select Remote Start, set a desired engine duration for remote start and temperature control settings, then input your Bluelink PIN.

30

²⁹ https://www.hgmanual.com/description_and_operation-1226.html.

³⁰ <https://owners.hyundaiusa.com/content/dam/hyundai/us/myhyundai/manuals/factory-warranty/2022/Bluelink-User-Manual.pdf>.

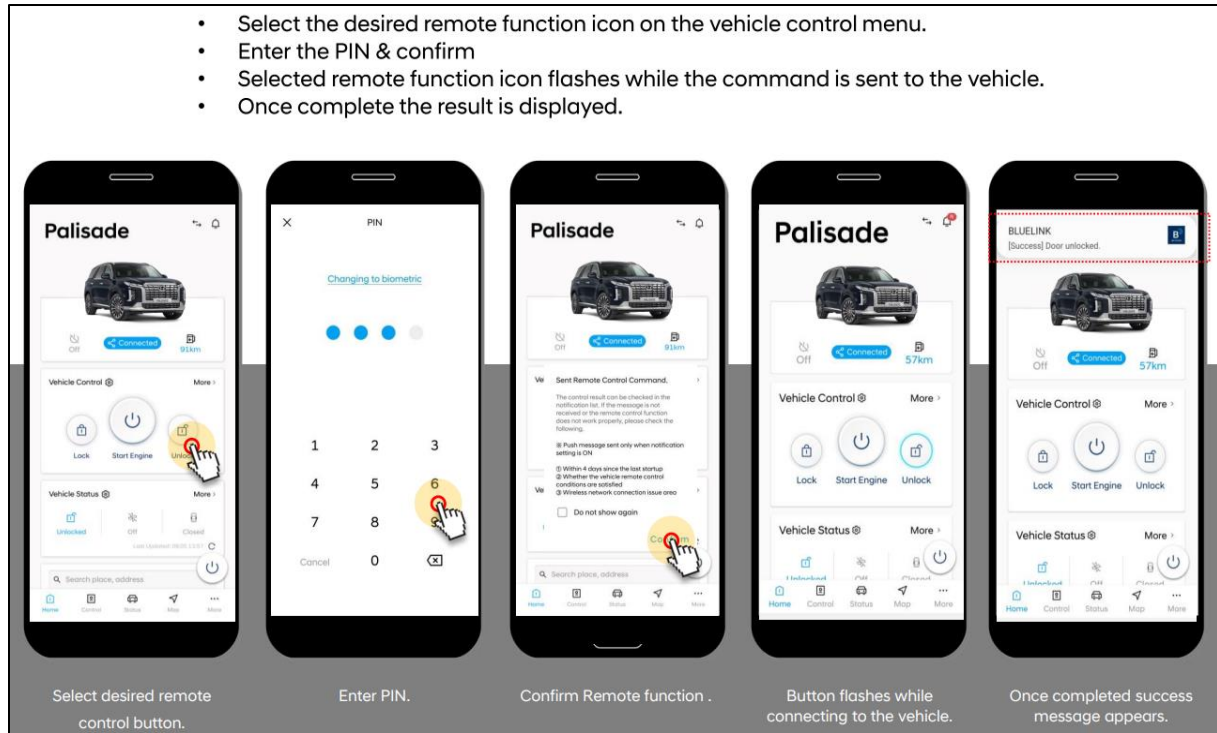

31

43. The Hyundai Sonata comprises a plurality of monitoring units wherein the at least one basic monitoring unit (e.g., a mobile device running the My Hyundai App with Bluelink Remote Service) is configured to receive the push programmatic instructions (e.g., vehicle status data) and in response thereto to receive a subset of the plurality of data values (e.g. vehicle status) from the at least one interface unit (e.g. the telematics control unit of the vehicle) using the first protocol (e.g. a cellular network):

The new home page will greet you, and in most cases, an image representing your vehicle will appear along with a quick view of your vehicle name, door lock status, fuel or battery status, and estimated range. The page provides access to these features:

- Your vehicle status information
- Remote Commands such as Start, Lock, Unlock, Stop, or Locate Vehicle
- Options to View Vehicle Status page and Start Charging (for EV vehicles)
- Driving Score (if enabled)
- Vehicle Safeguard Alerts
- Utilities Menu (three bars on the bottom left)
- Message Center (envelope icon on the bottom right)

32

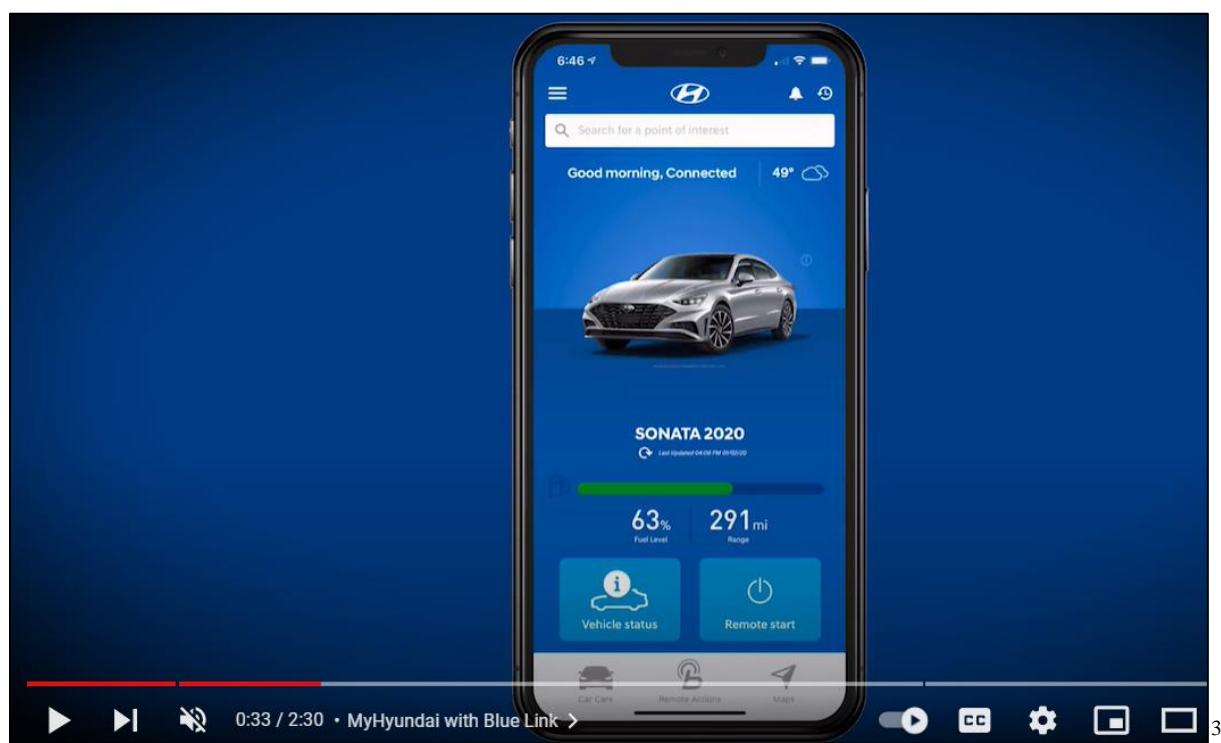

33

³² <https://owners.hyundaiusa.com/us/en/resources/technology-and-navigation/getting-to-know-the-redesigned-myhyundai-app.html>.

³³ <https://www.youtube.com/watch?v=jg3BCA6YzcY>.

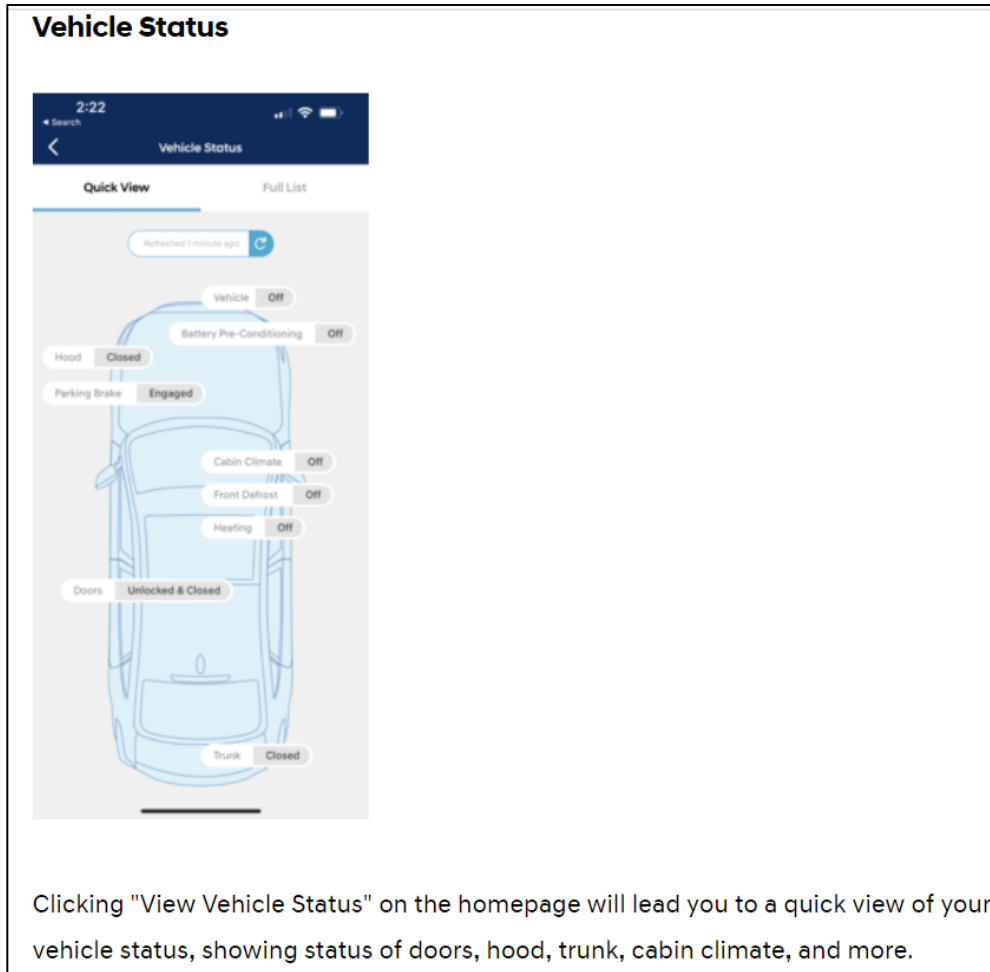

34

³⁴ <https://owners.hyundaiusa.com/us/en/resources/technology-and-navigation/getting-to-know-the-redesigned-myhyundai-app.html>.

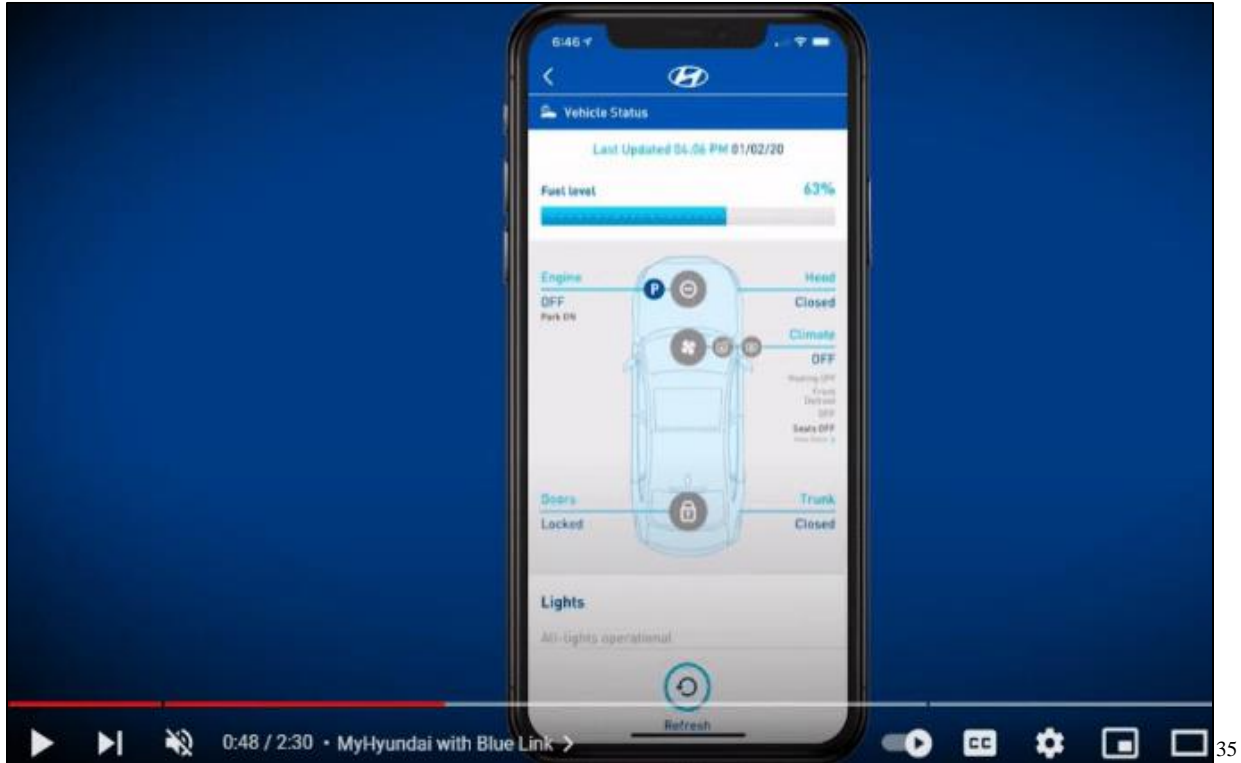

35

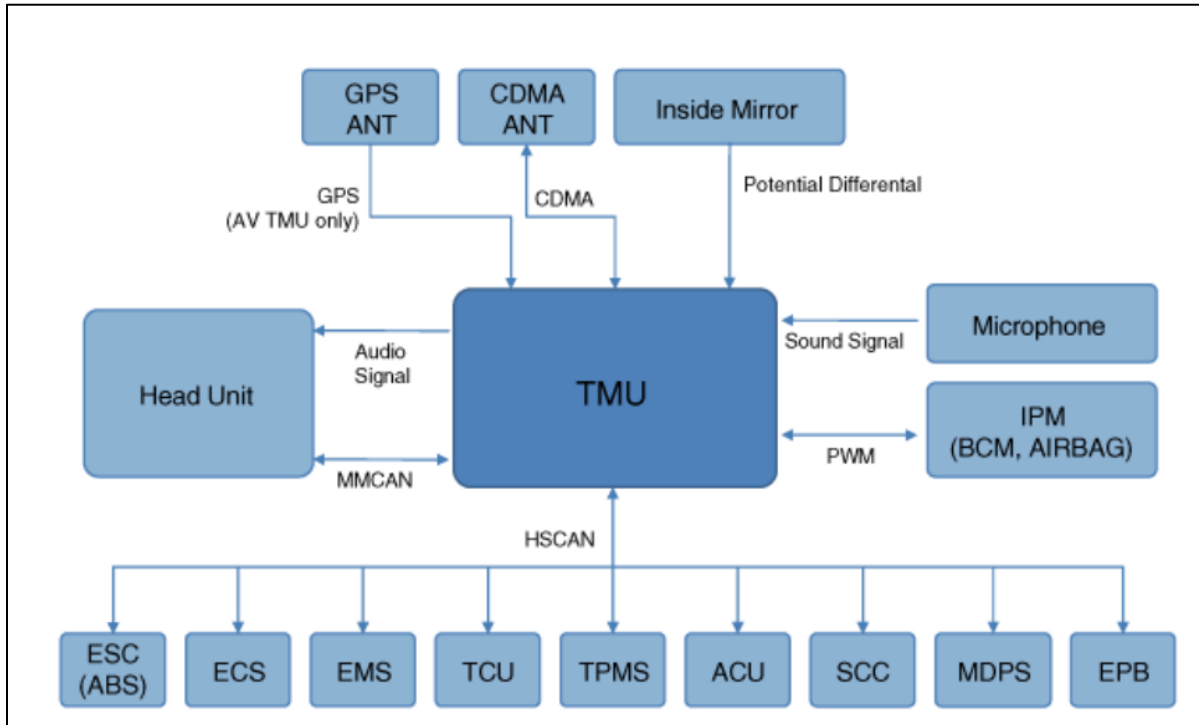

36

³⁵ <https://www.youtube.com/watch?v=jg3BCA6YzcY>.

³⁶ https://www.hgmanual.com/description_and_operation-1226.html.

44. Defendants have and continue to indirectly infringe one or more claims of the '002 Patent by knowingly and intentionally inducing others, including Hyundai customers and end-users, to directly infringe, either literally or under the doctrine of equivalents, by making, using, offering to sell, selling, and/or importing into the United States products that include infringing technology.

45. Defendants, with knowledge that these products, or the use thereof, infringe the '002 Patent at least as of the date of this Complaint, knowingly and intentionally induced, and continue to knowingly and intentionally induce, direct infringement of the '002 Patent by providing these products to customers and end-users for use in an infringing manner. Alternatively, on information and belief, Defendants have adopted a policy of not reviewing the patents of others, including specifically those related to Defendants' specific industry, thereby remaining willfully blind to the Patents-in-Suit at least as early as the issuance of the Patents-in-Suit.

46. Defendants have and continue to induce infringement by others, including customers and end-users, with the intent to cause infringing acts by others or, in the alternative, with the belief that there was a high probability that others, including end-users, infringe the '002 Patent, but while remaining willfully blind to the infringement. Defendants have and continue to induce infringement by their customers and end-users by supplying them with instructions on how to operate the infringing technology in an infringing manner, while also making publicly available information on the infringing technology via Defendants' website, product literature and packaging, and other publications.³⁷

³⁷ See, e.g., Hyundai Owner's Manuals, Quick Reference Guides, and other materials, available at: <https://owners.hyundaiusa.com/us/en/resources/manuals-warranties>.

47. LAG has suffered damages as a result of Defendants' direct and indirect infringement of the '002 Patent in an amount to be proved at trial.

48. LAG has suffered, and will continue to suffer, irreparable harm as a result of Defendants' infringement of the '002 Patent, for which there is no adequate remedy at law, unless Defendants' infringement is enjoined by this Court.

COUNT III
(Infringement of the '238 Patent)

49. Paragraphs 1 through 21 are incorporated by reference as if fully set forth herein.

50. LAG has not licensed or otherwise authorized Defendants to make, use, offer for sale, sell, or import any products that embody the inventions of the '238 Patent.

51. Defendants have and continue to infringe the '238 Patent, either literally or under the doctrine of equivalents, without authority and in violation of 35 U.S.C. § 271, by one or more of making, using, offering to sell, selling, and/or importing into the United States products that satisfy each and every limitation of one or more claims of the '238 Patent. Such products include, but are not limited to, the Accused Vehicles equipped with a direct injecting internal combustion engine, or the equivalent thereto, included in commercial and personal vehicles, in all trims and configurations.

52. For example, Defendants have and continue to directly infringe at least claim 1 of the '238 Patent by making, using, offering to sell, selling, and/or importing into the United States products that include a direct injecting internal combustion engine, such as the Gamma 1.6 Turbo GDI Engine in the Hyundai Accent, among other products.

53. The Hyundai Accent comprises a directly injecting internal combustion engine (e.g., the Gamma 1.6 Turbo GDI Engine), comprising at least one cylinder which has a combustion space:

The all-new Gamma 1.6-liter four-cylinder engine is the smallest Hyundai engine to use Gasoline Direct Injection (GDI) in the U.S., which helps deliver an estimated highway fuel economy of up to 40 mpg, lower emissions and higher reliability. Through the use of GDI technology, the Gamma 1.6-liter engine delivers a peak output of 138 horsepower at 6,300 rpm and maximum torque of 123 lb.-ft. at 4,850 rpm. However, GDI is only part of the story, as the new Gamma also features Dual Continuously Variable Valve Timing, an electronic throttle control, a roller timing chain, variable induction and innovative anti-friction coatings such as CrN Physical Vapor Deposition (PVD) coating and Diamond Like Carbon (DLC) coating.

38



39

Therefore in order to optimize the combustion system, we must optimize the design of the combustion chamber that determines the combustion speed, composition inside combustion chamber and heat transfer through the combustion chamber surfaces. For example, the shape of the intake port affects not only the in-cylinder flow and thus the combustion speed, but also controls the composition and heat transfer as well. Similarly, the shape of the piston not only affects the flow inside combustion chamber, but also the surface heat transfer. In addition the interactions between these components should also be considered.

40

54. The Hyundai Accent comprises a directly injecting internal combustion engine (e.g., the Gamma 1.6 Turbo GDI Engine), comprising at least one cylinder which has a combustion space in which a piston executes an oscillating movement (e.g., the piston moving upwards to

³⁸ <https://www.hyundai.com/worldwide/en/company/newsroom/hyundai-1.6-liter-gamma-engine-named-to-ward%25E2%2580%2599s-10-best-engines-list-0000001092>.

³⁹ <https://www.youtube.com/watch?v=8h49zmB7sos>.

⁴⁰ <https://www.scribd.com/document/553757052/1-6-Turbo-Gdi-Hyundai-Kim-e#>.

compress air-fuel mixture within the cylinder), and an injection nozzle for injection of fuel into the combustion space:

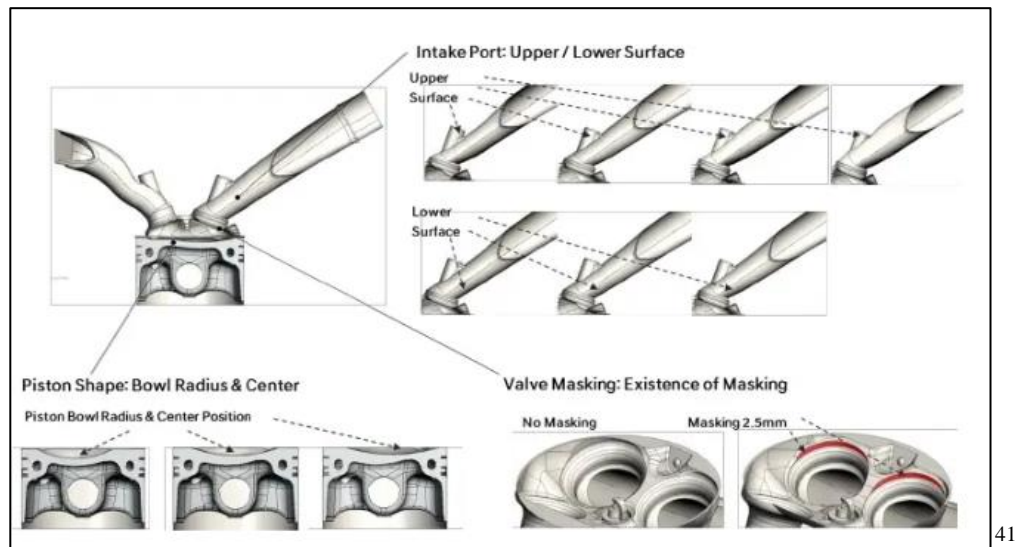

41

open during significant portion of the compression stroke, and it turns out that a large amount of the flow momentum generated during the intake stroke is lost back to the intake port when the valve mask is not existent. However if we apply a well-designed intake valve mask, we could block the flow tumble momentum going back to the intake port and preserve it inside the combustion chamber as shown in figure 6. In addition, this helps to maintain the center of the tumble near the center of the pent-roof combustion chamber which prevents the early breakdown of the flow into smaller scale turbulence.

42

⁴¹ <https://www.scribd.com/document/553757052/1-6-Turbo-Gdi-Hyundai-Kim-e#>.

⁴² *Id.*

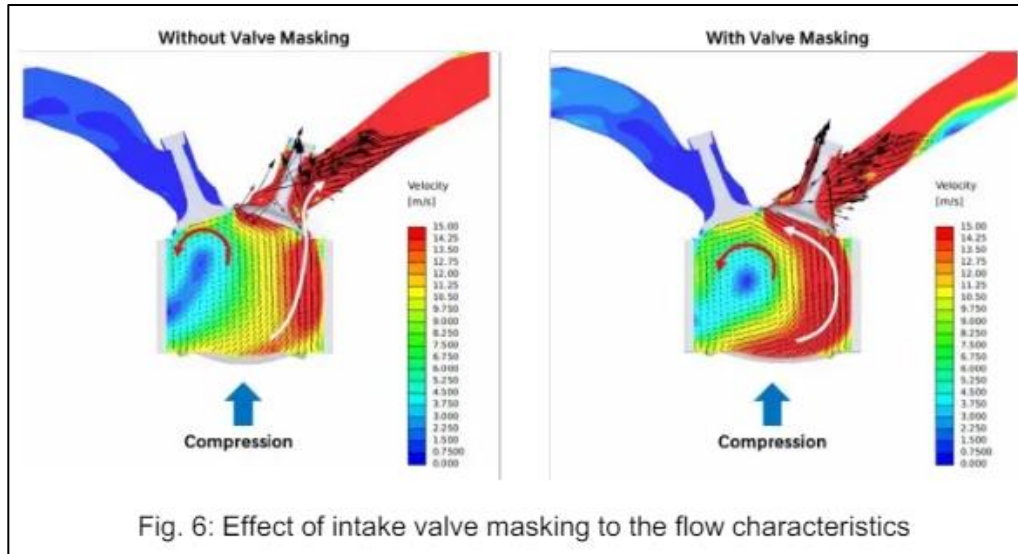

43

The injection is split into two phases to achieve optimum combustion: in the first phase, the pilot injection and ignition trigger the piston's downward power stroke. Then, in the main injection phase, during the piston's descent, more fuel is injected and is ignited. This split-injection technique reduces loading on the catalytic converter and helps lower emissions. This is particularly beneficial during cold starts when emissions are highest because the catalyst has not reached its optimal operating temperature. Split-injection enables the catalytic converter to reach the optimal operating temperature faster thus reducing emissions by 25 percent during cold starts and meet's California Air Resources Board's ULEV-2 and PZEV standards

44

In order to maximize the benefits of higher fuel pressure, newly developed next generation injectors are applied. As shown in figure 20, the HMG developed 350bar injectors have been extensively improved in terms of the nozzle structure, the dynamic fuel metering enhancement and durability in relation to increased fuel pressure.

45

⁴³ *Id.*

⁴⁴ *Id.*

⁴⁵ <https://www.scribd.com/document/553757052/1-6-Turbo-Gdi-Hyundai-Kim-e#>.

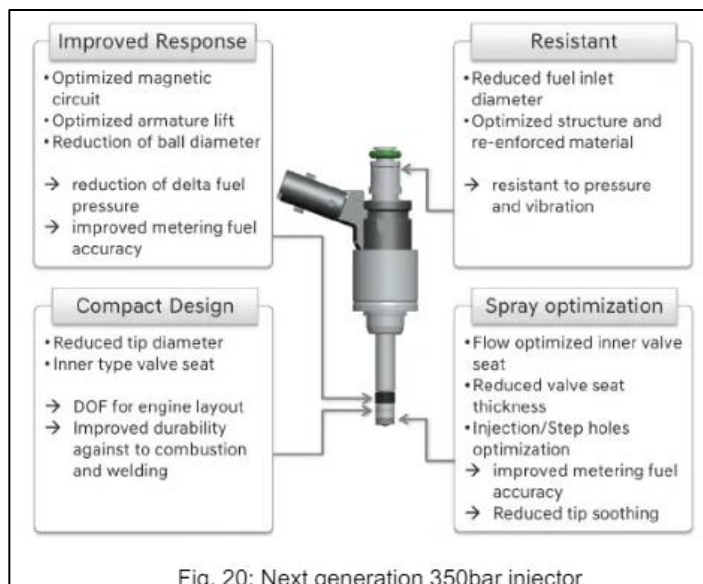

55. The Hyundai Accent comprises a directly injecting internal combustion engine (e.g., the Gamma 1.6 Turbo GDI Engine), comprising at least one cylinder which has a combustion space in which a piston executes an oscillating movement (e.g., the piston moving upwards to compress air-fuel mixture within the cylinder), and an injection nozzle for injection of fuel into the combustion space wherein the piston has a piston recess (e.g., a bowl like shape), which, in a central region thereof, has an elevation extending in a cylinder head direction, and a surface of the piston recess adjoining the elevation in a recess edge direction is connected to the elevation via a radius (e.g., the radius of the bowl shape):

To optimize the 5 parameters, 16 different DoE combustion chambers were designed as shown in figure 4. Based on the designs, we have prototyped four special engine heads with all 16 individual combustion chambers composed of the 16 DoE combustion chambers that we described above. We performed the combustion evaluation using these 4 special heads in the real firing engine. We also have performed the computational simulations for these 16 different combustion systems in order to understand the effect of the each parameter in more detail. 47

⁴⁶ *Id.*

⁴⁷ *Id.*



48



49

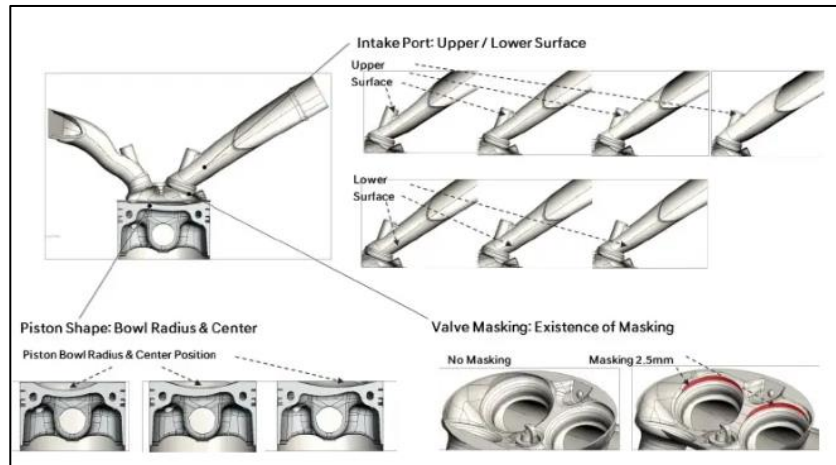

50

⁴⁸ <https://www.jepistons.com/product/je-pistons-hyundai-1-6l-gamma-turbo-gdi-piston-77-00-mm-bore-1-099-in-ch-8-20-cc/>.

⁴⁹ <https://www.youtube.com/watch?v=0n3jim7yITA>.

⁵⁰ <https://www.scribd.com/document/553757052/1-6-Turbo-Gdi-Hyundai-Kim-e#>.

To optimize this complex system, we decided to use the Design of Experiment (DoE) approach. By analyzing the system, we chose 5 important design parameters to optimize the combustion chamber. The 5 parameters are shown in figure 3, and they are intake port upper curvature, lower curvature, piston bowl position, bowl radius, and valve masking.

51

56. The Hyundai Accent comprises a directly injecting internal combustion engine (e.g., the Gamma 1.6 Turbo GDI Engine), comprising at least one cylinder which has a combustion space in which a piston executes an oscillating movement (e.g., the piston moving upwards to compress air-fuel mixture within the cylinder), and an injection nozzle for injection of fuel into the combustion space wherein the piston has a piston recess (e.g., a bowl like shape), which, in a central region thereof, has an elevation extending in a cylinder head direction, and a surface of the piston recess adjoining the elevation in a recess edge direction is connected to the elevation via a radius (e.g., the radius of the bowl shape) so that an injection jet impinging the surface and injected as early as possible is distributed both in a elevation direction and in the recess edge direction, and the surface is substantially planar and has an ascending gradient in the recess edge direction such that an injection jet injected as late as possible impinges onto the surface, the last-mentioned injection jet being distributed both in the elevation direction and in the recess edge direction:

⁵¹ *Id.*

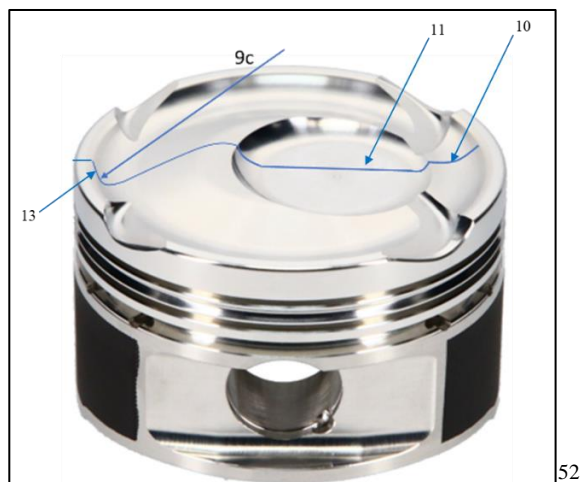

57. Defendants have and continue to indirectly infringe one or more claims of the '238 Patent by knowingly and intentionally inducing others, including Hyundai customers and end-users, to directly infringe, either literally or under the doctrine of equivalents, by making, using, offering to sell, selling, and/or importing into the United States products that include infringing technology.

58. Defendants, with knowledge that these products, or the use thereof, infringe the '238 Patent at least as of the date of this Complaint, knowingly and intentionally induced, and continue to knowingly and intentionally induce, direct infringement of the '238 Patent by providing these products to customers and end-users for use in an infringing manner. Alternatively, on information and belief, Defendants have adopted a policy of not reviewing the patents of others, including specifically those related to Defendants' specific industry, thereby remaining willfully blind to the Patents-in-Suit at least as early as the issuance of the Patents-in-Suit.

59. Defendants have and continue to induce infringement by others, including

⁵² <https://www.jepistons.com/product/je-pistons-hyundai-1-6l-gamma-turbo-gdi-piston-77-00-mm-bore-1-099-in-ch-8-20-cc/>.

customers and end-users, with the intent to cause infringing acts by others or, in the alternative, with the belief that there was a high probability that others, including end-users, infringe the '238 Patent, but while remaining willfully blind to the infringement. Defendants have and continue to induce infringement by their customers and end-users by supplying them with instructions on how to operate the infringing technology in an infringing manner, while also making publicly available information on the infringing technology via Defendants' website, product literature and packaging, and other publications.⁵³

60. LAG has suffered damages as a result of Defendants' direct and indirect infringement of the '238 Patent in an amount to be proved at trial.

61. LAG has suffered, and will continue to suffer, irreparable harm as a result of Defendants' infringement of the '238 Patent, for which there is no adequate remedy at law, unless Defendants' infringement is enjoined by this Court.

COUNT IV
(Infringement of the '353 Patent)

62. Paragraphs 1 through 21 are incorporated by reference as if fully set forth herein.

63. LAG has not licensed or otherwise authorized Defendants to make, use, offer for sale, sell, or import any products that embody the inventions of the '353 Patent.

64. Defendants have and continue to infringe the '353 Patent, either literally or under the doctrine of equivalents, without authority and in violation of 35 U.S.C. § 271, by one or more of making, using, offering to sell, selling, and/or importing into the United States products that satisfy each and every limitation of one or more claims of the '353 Patent. Such products include, but are not limited to, the Accused Vehicles equipped Hyundai's SmartSense integrated with a

⁵³ See, e.g., Hyundai Owner's Manuals, Quick Reference Guides, and other materials, available at: <https://owners.hyundaiusa.com/us/en/resources/manuals-warranties>.

communication controller, such as the Hyundai Mobis Integrated Communication Controller, or the equivalent thereto, included in commercial and personal vehicles, in all trims and configurations.

65. For example, Defendants have and continue to directly infringe at least claim 1 of the '353 Patent by making, using, offering to sell, selling, and/or importing into the United States products that include Hyundai SmartSense, such as the Hyundai Kona, among other products.

66. The Hyundai Kona performs a method of forming an image of a mobile object:

The Integrated Communication Controller, developed by Hyundai Mobis, connects various Electronic Control Units (ECU) mounted on the vehicle, e.g. the powertrain, multimedia, airbags and brake systems, through wired communication to collect and analyze various kinds of vehicle operation data in real time. It can process large amounts of data, including the data from various sensors like radars, lidars and cameras, and autonomous driving-related data.

It also communicates this information with the outside through full-time wireless network connectivity. It can also implement various connected car services, such as remote vehicle control and automatic update of the software of various systems, and functions like eCall which automatically transmits accident information in case of an emergency.



Hyundai Mobis Integrated Communication Controller

54

67. The Hyundai Kona performs the step of obtaining a plurality of first images of the mobile object using a first imaging technique (e.g., the Bird's-eye image camera processing) while obtaining a plurality of first measurements corresponding to movements of the mobile object using a first sensor system (e.g., ultrasonic sensor), the first sensor system being independent from the first imaging technique (e.g., the Bird's-eye image camera processing):

⁵⁴ <https://www.prnewswire.com/news-releases/hyundai-mobis-develops-integrated-communication-controller-the-next-generation-v2x-control-technology-for-the-first-time-in-korea-301084287.html>.



Surround View Monitor (SVM)

Shows you the bird's-eye camera views from the sides and rear of your vehicle on your touchscreen display. ⓘ

55

⁵⁵ <https://www.hyundaiusa.com/us/en/safety>.



⁵⁶ https://youtu.be/Y82vK_E6c08?si=0SYuXC3qDtSzAr5d.

⁵⁷ *Id.*



58

⁵⁸ *Id.*

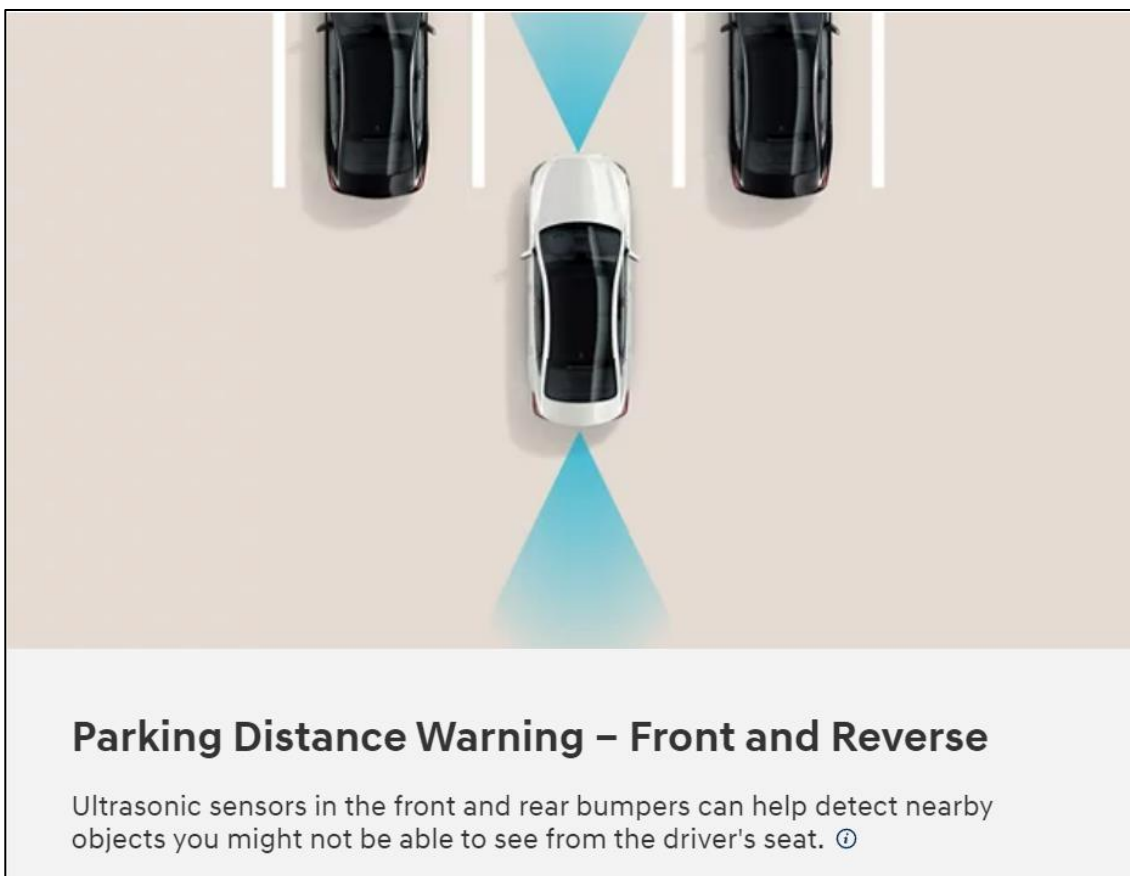

68. The Hyundai Kona performs the step of associating the plurality of first images (e.g., the Bird's-eye view) with first movement states of the mobile object using the first measurements (e.g., ultrasonic sensor data):

⁵⁹ <https://www.hyundaiusa.com/us/en/safety>.

The Integrated Communication Controller, developed by Hyundai Mobis, connects various Electronic Control Units (ECU) mounted on the vehicle, e.g. the powertrain, multimedia, airbags and brake systems, through wired communication to collect and analyze various kinds of vehicle operation data in real time. It can process large amounts of data, including the data from various sensors like radars, lidars and cameras, and autonomous driving-related data.

It also communicates this information with the outside through full-time wireless network connectivity. It can also implement various connected car services, such as remote vehicle control and automatic update of the software of various systems, and functions like eCall which automatically transmits accident information in case of an emergency.



Hyundai Mobis Integrated Communication Controller

60

⁶⁰ <https://www.prnewswire.com/news-releases/hyundai-mobis-develops-integrated-communication-controller-the-next-generation-v2x-control-technology-for-the-first-time-in-korea-301084287.html>.



Surround View Monitor (SVM)

Shows you the bird's-eye camera views from the sides and rear of your vehicle on your touchscreen display. ⓘ

61

⁶¹ <https://www.hyundaiusa.com/us/en/safety>.



⁶² https://youtu.be/Y82vK_E6c08?si=0SYuXC3qDtSzAr5d.

⁶³ *Id.*



64

⁶⁴ *Id.*



65

69. The Hyundai Kona performs the step of obtaining a plurality of second images of the mobile object using a second imaging technique (e.g., forward camera image processing) while obtaining a plurality of second measurements corresponding to movements of the mobile object using a second sensor system (e.g., radar sensors), the second sensor system being independent from the second imaging technique (e.g., forward camera image processing):

⁶⁵ <https://www.hyundaiusa.com/us/en/safety>.



Forward Collision-Avoidance Assist with Pedestrian Detection (FCA-Ped)

When the system detects a vehicle or pedestrian in your path, it warns you of a potential collision. If you don't begin stopping in time, the system may automatically apply braking. ⓘ

66

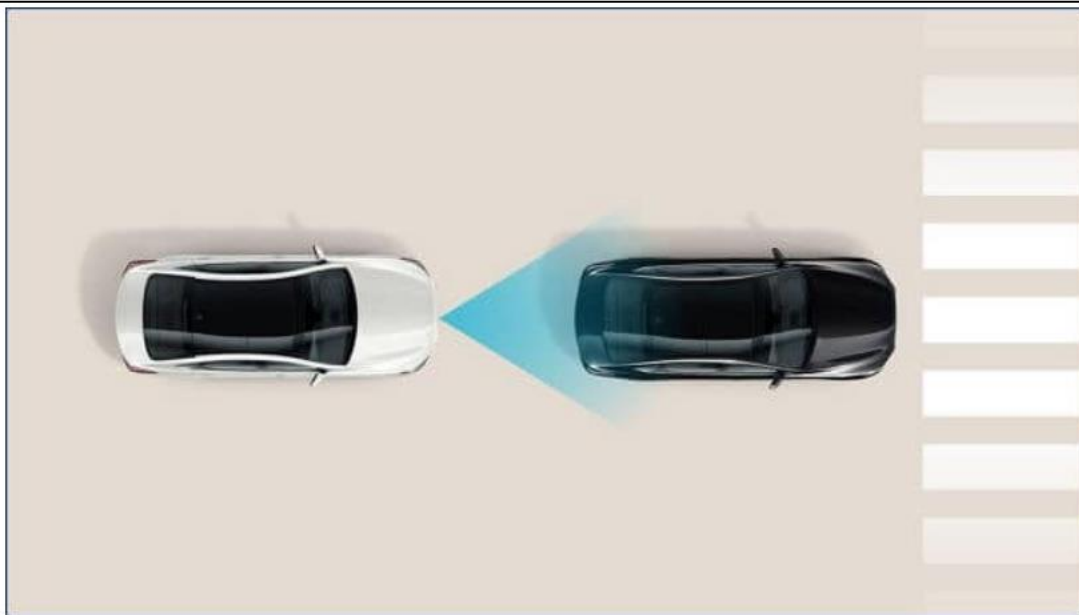

Forward Collision-Avoidance Assist with Pedestrian Detection (FCA-Ped)

Hyundai SmartSense Feature

When the forward camera and radar detect a vehicle or pedestrian in your path, FCA-Ped will warn lowa drivers of a potential collision. If you don't begin stopping in time, the system will automatically apply emergency braking.

67

⁶⁶ <https://www.hyundaiusa.com/us/en/safety>.

⁶⁷ <https://www.verneidehyundaisiouxcity.com/hyundai-smartsense-safety-pack/>.

70. The Hyundai Kona performs the step of associating the plurality of second images (e.g., images from the forward camera) with second movement states of the mobile object using the first measurements (e.g., radar sensor data using the ultrasonic sensor data):

The Integrated Communication Controller, developed by Hyundai Mobis, connects various Electronic Control Units (ECU) mounted on the vehicle, e.g. the powertrain, multimedia, airbags and brake systems, through wired communication to collect and analyze various kinds of vehicle operation data in real time. It can process large amounts of data, including the data from various sensors like radars, lidars and cameras, and autonomous driving-related data.

It also communicates this information with the outside through full-time wireless network connectivity. It can also implement various connected car services, such as remote vehicle control and automatic update of the software of various systems, and functions like eCall which automatically transmits accident information in case of an emergency.



Hyundai Mobis Integrated Communication Controller

68

⁶⁸ <https://www.prnewswire.com/news-releases/hyundai-mobis-develops-integrated-communication-controller-the-next-generation-v2x-control-technology-for-the-first-time-in-korea-301084287.html>.



Surround View Monitor (SVM)

Shows you the bird's-eye camera views from the sides and rear of your vehicle on your touchscreen display. ⓘ

69

⁶⁹ <https://www.hyundaiusa.com/us/en/safety>.



⁷⁰ https://youtu.be/Y82vK_E6c08?si=0SYuXC3qDtSzAr5d.

⁷¹ *Id.*



72

⁷² *Id.*



The diagram shows a top-down view of a white car parked in a space between two black cars. Two light blue triangular beams, representing ultrasonic sensors, extend forward from the front of the white car and backward from the rear. The background is a light beige color with white vertical lines indicating parking spaces.

Parking Distance Warning – Front and Reverse

Ultrasonic sensors in the front and rear bumpers can help detect nearby objects you might not be able to see from the driver's seat. ⓘ

73

⁷³ <https://www.hyundaiusa.com/us/en/safety>.



Forward Collision-Avoidance Assist with Pedestrian Detection (FCA-Ped)

When the system detects a vehicle or pedestrian in your path, it warns you of a potential collision. If you don't begin stopping in time, the system may automatically apply braking. ⓘ

74

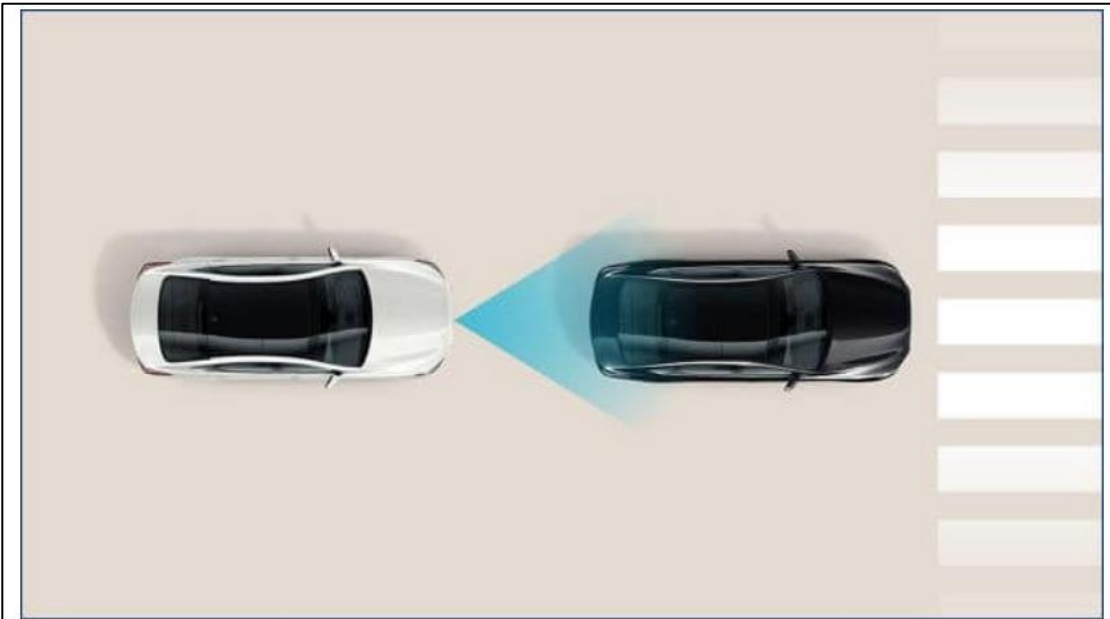

Forward Collision-Avoidance Assist with Pedestrian Detection (FCA-Ped)

Hyundai SmartSense Feature

When the forward camera and radar detect a vehicle or pedestrian in your path, FCA-Ped will warn lowa drivers of a potential collision. If you don't begin stopping in time, the system will automatically apply emergency braking.

75

⁷⁴ <https://www.hyundaiusa.com/us/en/safety>.

⁷⁵ <https://www.verneidehyundaisiouxcity.com/hyundai-smartsense-safety-pack/>.

71. The Hyundai Kona performs the step of forming an image of the mobile object based on said plurality of first images (e.g., images from the Bird's-eye view cameras), said associated plurality of first movement measurements, and said first movement states (e.g., ultrasonic sensors) and on said plurality of second images (e.g. images from the forward camera), said associated plurality of second movement measurements, and said second movement states (e.g., from the radar sensors), wherein the first imaging technique (e.g., the Bird's-eye view cameras) is different from the second imaging technique (e.g., the forward camera):

The Integrated Communication Controller, developed by Hyundai Mobis, connects various Electronic Control Units (ECU) mounted on the vehicle, e.g. the powertrain, multimedia, airbags and brake systems, through wired communication to collect and analyze various kinds of vehicle operation data in real time. It can process large amounts of data, including the data from various sensors like radars, lidars and cameras, and autonomous driving-related data.

It also communicates this information with the outside through full-time wireless network connectivity. It can also implement various connected car services, such as remote vehicle control and automatic update of the software of various systems, and functions like eCall which automatically transmits accident information in case of an emergency.



Hyundai Mobis Integrated Communication Controller

76

⁷⁶ <https://www.prnewswire.com/news-releases/hyundai-mobis-develops-integrated-communication-controller-the-next-generation-v2x-control-technology-for-the-first-time-in-korea-301084287.html>.



Surround View Monitor (SVM)

Shows you the bird's-eye camera views from the sides and rear of your vehicle on your touchscreen display. ⓘ

77

⁷⁷ <https://www.hyundaiusa.com/us/en/safety>.



⁷⁸ https://youtu.be/Y82vK_E6c08?si=0SYuXC3qDtSzAr5d.

⁷⁹ *Id.*



80

⁸⁰ *Id.*



The diagram shows a top-down view of a white car parked in a space between two black cars. Two light blue triangular beams, representing ultrasonic sensors, extend forward from the front of the white car and backward from the rear. The background is a light beige color with white vertical lines indicating parking spaces.

Parking Distance Warning – Front and Reverse

Ultrasonic sensors in the front and rear bumpers can help detect nearby objects you might not be able to see from the driver's seat. ⓘ

81

⁸¹ <https://www.hyundaiusa.com/us/en/safety>.



Forward Collision-Avoidance Assist with Pedestrian Detection (FCA-Ped)

When the system detects a vehicle or pedestrian in your path, it warns you of a potential collision. If you don't begin stopping in time, the system may automatically apply braking. ⓘ

82

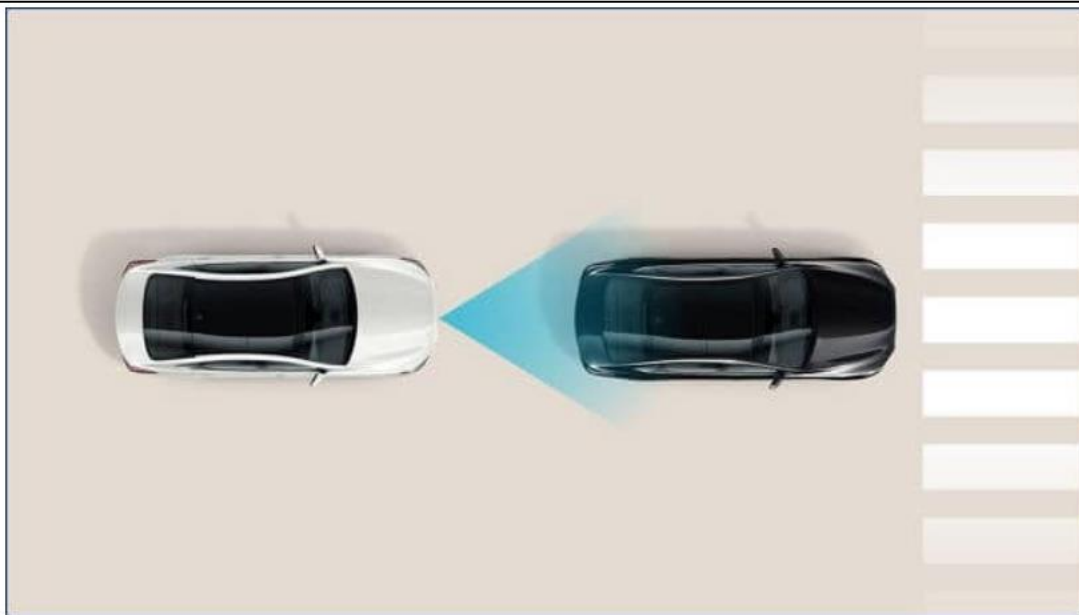

Forward Collision-Avoidance Assist with Pedestrian Detection (FCA-Ped)

Hyundai SmartSense Feature

When the forward camera and radar detect a vehicle or pedestrian in your path, FCA-Ped will warn lowa drivers of a potential collision. If you don't begin stopping in time, the system will automatically apply emergency braking.

83

⁸² <https://www.hyundaiusa.com/us/en/safety>.

⁸³ <https://www.verneidehyundaisiouxcity.com/hyundai-smartsense-safety-pack/>.

72. Defendants have and continue to indirectly infringe one or more claims of the '353 Patent by knowingly and intentionally inducing others, including Hyundai customers and end-users, to directly infringe, either literally or under the doctrine of equivalents, by making, using, offering to sell, selling, and/or importing into the United States products that include infringing technology.

73. Defendants, with knowledge that these products, or the use thereof, infringe the '353 Patent at least as of the date of this Complaint, knowingly and intentionally induced, and continue to knowingly and intentionally induce, direct infringement of the '353 Patent by providing these products to customers and end-users for use in an infringing manner. Alternatively, on information and belief, Defendants have adopted a policy of not reviewing the patents of others, including specifically those related to Defendants' specific industry, thereby remaining willfully blind to the Patents-in-Suit at least as early as the issuance of the Patents-in-Suit.

74. Defendants have and continue to induce infringement by others, including customers and end-users, with the intent to cause infringing acts by others or, in the alternative, with the belief that there was a high probability that others, including end-users, infringe the '353 Patent, but while remaining willfully blind to the infringement. Defendants have and continue to induce infringement by their customers and end-users by supplying them with instructions on how to operate the infringing technology in an infringing manner, while also making publicly available information on the infringing technology via Defendants' website, product literature and packaging, and other publications.⁸⁴

⁸⁴ See, e.g., Hyundai Owner's Manuals, Quick Reference Guides, and other materials, available at: <https://owners.hyundaiusa.com/us/en/resources/manuals-warranties>.

75. LAG has suffered damages as a result of Defendants' direct and indirect infringement of the '353 Patent in an amount to be proved at trial.

76. LAG has suffered, and will continue to suffer, irreparable harm as a result of Defendants' infringement of the '353 Patent, for which there is no adequate remedy at law, unless Defendants' infringement is enjoined by this Court.

COUNT V
(Infringement of the '331 Patent)

77. Paragraphs 1 through 21 are incorporated by reference as if fully set forth herein.

78. LAG has not licensed or otherwise authorized Defendants to make, use, offer for sale, sell, or import any products that embody the inventions of the '331 Patent.

79. Defendants have and continue to infringe the '331 Patent, either literally or under the doctrine of equivalents, without authority and in violation of 35 U.S.C. § 271, by one or more of making, using, offering to sell, selling, and/or importing into the United States products that satisfy each and every limitation of one or more claims of the '331 Patent. Such products include, but are not limited to, Accused Vehicles equipped with advanced driver assistance systems, such as Hyundai's SmartSense, or the equivalent thereto, included in commercial and personal vehicles, in all trims and configurations.

80. For example, Defendants have and continue to directly infringe at least claim 1 of the '331 Patent by making, using, offering to sell, selling, and/or importing into the United States products that include Hyundai SmartSense, such as the Hyundai Kona, among other products.

81. The Hyundai Kona comprises a collision prevention detector to be mounted on a vehicle, transmitting a sequence of transmissions of IR signals, whereby the signals are transmitted in sequences alternating between at least one at the right and to the left positioned LED, when both signals provide a return/reflected signal to an IR-receiver an object is determined as present within

an area from the point where the transmitted signals intersect/cross, whereby the sequencing of signals makes it possible to position a return signal from the object, as one of the signals has to confirm the other signal to provide a warning signal.

82. The Hyundai Kona comprises at least two sets of said LED's LEDs positioned to the right and to the left, whereby a first set detects objects in a near-field zone of the vehicle, and a second set beyond said first field in a far-field zone, wherein the at least two sets of LEDs are configured to transmit a sequence of transmissions of IR signals alternating between at least one LED to the right and at least one LED to the left.

83. The Hyundai Kona comprises at least one IR receiver configured to receive the sequence of transmissions of IR signals such that receiving both of the alternating IR signals indicates the presence of an object within an area where the transmitted signals cross.

84. The Hyundai Kona comprises a processor connected to said first and second sets for detection of the at least one IR receiver configured to detect the object in the near-field and far-field zones and being provided the vehicle speed.

85. The Hyundai Kona comprises a comparator connected to or comprised in said associated with the processor, which compares the vehicle speed with configured to compare a vehicle speed with a pre-determined loss of measured distance by measuring how fast the vehicle approaches said the object by closing in from the far-field zone to the near-field zone, whereby an alarm is given through by an indicator device mounted on said vehicle alerting a vehicle driver to pay attention to the closing in of an approaching object.

86. Defendants have and continue to indirectly infringe one or more claims of the '331 Patent by knowingly and intentionally inducing others, including Hyundai customers and end-users, to directly infringe, either literally or under the doctrine of equivalents, by making, using,

offering to sell, selling, and/or importing into the United States products that include infringing technology.

87. Defendants, with knowledge that these products, or the use thereof, infringe the '331 Patent at least as of the date of this Complaint, knowingly and intentionally induced, and continue to knowingly and intentionally induce, direct infringement of the '331 Patent by providing these products to customers and end-users for use in an infringing manner. Alternatively, on information and belief, Defendants have adopted a policy of not reviewing the patents of others, including specifically those related to Defendants' specific industry, thereby remaining willfully blind to the Patents-in-Suit at least as early as the issuance of the Patents-in-Suit.

88. Defendants have and continue to induce infringement by others, including customers and end-users, with the intent to cause infringing acts by others or, in the alternative, with the belief that there was a high probability that others, including end-users, infringe the '331 Patent, but while remaining willfully blind to the infringement. Defendants have and continue to induce infringement by their customers and end-users by supplying them with instructions on how to operate the infringing technology in an infringing manner, while also making publicly available information on the infringing technology via Defendants' website, product literature and packaging, and other publications.⁸⁵

89. LAG has suffered damages as a result of Defendants' direct and indirect infringement of the '331 Patent in an amount to be proved at trial.

90. LAG has suffered, and will continue to suffer, irreparable harm as a result of

⁸⁵ See, e.g., Hyundai Owner's Manuals, Quick Reference Guides, and other materials, available at: <https://owners.hyundaiusa.com/us/en/resources/manuals-warranties>.

Defendants' infringement of the '331 Patent, for which there is no adequate remedy at law, unless Defendants' infringement is enjoined by this Court.

COUNT VI
(Infringement of the '101 Patent)

91. Paragraphs 1 through 21 are incorporated by reference as if fully set forth herein.

92. LAG has not licensed or otherwise authorized Defendants to make, use, offer for sale, sell, or import any products that embody the inventions of the '101 Patent.

93. Defendants have infringed the '101 Patent, either literally or under the doctrine of equivalents, without authority and in violation of 35 U.S.C. § 271, by one or more of making, using, offering to sell, selling, and/or importing into the United States products that satisfy each and every limitation of one or more claims of the '101 Patent. Such products include, but are not limited to, Accused Vehicles equipped with advanced driver assistance systems, such as Hyundai's SmartSense, or the equivalent thereto, included in commercial and personal vehicles, in all trims and configurations.

94. For example, Defendants have and continue to directly infringe at least claim 1 of the '101 Patent by making, using, offering to sell, selling, and/or importing into the United States products that include Hyundai SmartSense, such as the Hyundai Kona, among other products.

95. The Hyundai Kona performs a method for assisting the driver of a vehicle when performing a driving maneuver formed by a parking or shunting maneuver, a reference trajectory corresponding to the driving maneuver being determined, along which the vehicle is to be moved, and the steering wheel position to be set in each case and controlling the vehicle along the reference trajectory being indicated to the driver during the driving maneuver, the vehicle longitudinal speed being influenced independently of the driver in the event of a steering angle deviation between the

actual steering angle actually set by the driver and the desired steering angle corresponding to the requested steering wheel position, characterized in that the vehicle longitudinal speed is influenced on the basis of the magnitude of the steering angle deviation in such a way that a greater vehicle retardation is carried out, the greater the magnitude of the steering angle deviation is.

96. Through demonstrations, testing, repairs, and instructional guidance, Hyundai has used the Accused Vehicles in a manner that directly infringes at least claim 1 of the '101 Patent.

97. Defendants have indirectly infringed one or more claims of the '101 Patent by knowingly and intentionally inducing others, including Hyundai customers and end-users, to directly infringe, either literally or under the doctrine of equivalents, by making, using, offering to sell, selling, and/or importing into the United States products that include infringing technology.

98. Defendants, with knowledge⁸⁶ that these products, or the use thereof, infringe the '101 Patent at least as of the date of this Complaint, knowingly and intentionally induced direct infringement of the '101 Patent by providing these products to customers and end-users for use in an infringing manner. Alternatively, on information and belief, Defendants have adopted a policy of not reviewing the patents of others, including specifically those related to Defendants' specific industry, thereby remaining willfully blind to the Patents-in-Suit at least as early as the issuance of the Patents-in-Suit.

99. Defendants have induced infringement by others, including customers and end-users, with the intent to cause infringing acts by others or, in the alternative, with the belief that there was a high probability that others, including end-users, infringe the '101 Patent, but while remaining willfully blind to the infringement. Defendants have induced infringement by their

⁸⁶ Defendant Hyundai Motor Company cited to the '101 Patent family in relation to its own foreign patent application KR20160072576A, which was published on June 6, 2016, and was issued as KR102326052B1 on November 15, 2021.

customers and end-users by supplying them with instructions on how to operate the infringing technology in an infringing manner, while also making publicly available information on the infringing technology via Defendants' website, product literature and packaging, and other publications.⁸⁷

100. LAG has suffered damages as a result of Defendants' direct and indirect infringement of the '101 Patent in an amount to be proved at trial.

DEMAND FOR JURY TRIAL

Plaintiff hereby demands a jury for all issues so triable.

PRAYER FOR RELIEF

WHEREFORE, LAG prays for relief against Defendants as follows:

- a. Entry of judgment declaring that Defendants have directly and/or indirectly infringed one or more claims of the Patents-in-Suit;
- b. An order pursuant to 35 U.S.C. § 283 permanently enjoining Defendants, their officers, agents, servants, employees, attorneys, and those persons in active concert or participation with them, from further acts of infringement of the '803 Patent, the '002 Patent, the '238 Patent, the '353 Patent, and the '331 Patent;
- c. An order awarding damages sufficient to compensate LAG for Defendants' infringement of the Patents-in-Suit, but in no event less than a reasonable royalty, together with interest and costs;
- d. Entry of judgment declaring that this case is exceptional and awarding LAG its costs and reasonable attorney fees under 35 U.S.C. § 285; and

⁸⁷ See, e.g., Hyundai Owner's Manuals, Quick Reference Guides, and other materials, available at: <https://owners.hyundaiusa.com/us/en/resources/manuals-warranties>.

e. Such other and further relief as the Court deems just and proper.

Dated: July 19, 2024

Respectfully submitted,

/s/ Vincent J. Rubino, III

Alfred R. Fabricant

NY Bar No. 2219392

Email: ffabricant@fabricantllp.com

Peter Lambrianakos

NY Bar No. 2894392

Email: plambrianakos@fabricantllp.com

Vincent J. Rubino, III

NY Bar No. 4557435

Email: vrubino@fabricantllp.com

FABRICANT LLP

411 Theodore Fremd Road, Suite 206 South
Rye, NY 10580

Telephone: (212) 257-5797

Facsimile: (212) 257-5796

John Andrew Rubino

NY Bar No. 5020797

Email: jarubino@rubinoip.com

Michael Mondelli III

NY Bar No. 5805114

Email: mmondelli@rubinoip.com

RUBINO IP

51 J.F.K. Parkway

Short Hills, NJ, 07079

Telephone: (201) 341-9445

Facsimile: (973) 535-0921

**ATTORNEYS FOR PLAINTIFF,
LONGHORN AUTOMOTIVE GROUP
LLC**