

IN THE UNITED STATES DISTRICT COURT  
FOR THE DISTRICT OF DELAWARE

BOSTON DYNAMICS, INC.,	)	
	)	
Plaintiff,	)	C.A. No. 24-184 (MN)
	)	
v.	)	
	)	
GHOST ROBOTICS CORPORATION,	)	
	)	<b>JURY TRIAL DEMANDED</b>
Defendant.	)	REDACTED - PUBLIC VERSION

**FIRST AMENDED COMPLAINT**

Plaintiff Boston Dynamics, Inc. (“Boston Dynamics” or “Plaintiff”), hereby alleges the following against Defendant Ghost Robotics Corporation (“Ghost Robotics” or “Defendant”):

**NATURE OF ACTION**

1. This is an action for patent infringement arising under the Patent Laws of the United States, 35 U.S.C. §§ 1, *et seq.*
2. Plaintiff has filed this lawsuit to stop Defendant’s unlawful infringement of Plaintiff’s patented inventions and to obtain damages, an injunction, and other relief.

**THE PARTIES**

3. Boston Dynamics is a corporation organized and existing under the laws of the State of Delaware with its principal place of business located at 200 Smith Street, Waltham, MA 02451.
4. On information and belief, Ghost Robotics is a corporation organized and existing under the laws of the State of Delaware, and has a place of business at 3401 Grays Ferry Ave Bldg. 197 Ste 312, Philadelphia, PA 19146.

## **JURISDICTION AND VENUE**

5. This is an action for patent infringement arising under the patent laws of the United States of America, 35 U.S.C. §§ 1, *et. seq.*, including 35 U.S.C. § 271. This Court has subject matter jurisdiction pursuant to 28 U.S.C. §§ 1331 and 1338(a).

6. This Court has personal jurisdiction over Ghost Robotics based at least on Ghost Robotics' incorporation in the State of Delaware.

7. Venue is proper in this Court under 28 U.S.C. § 1400(b) because Ghost Robotics is incorporated in, and therefore resides in, the State of Delaware.

## **FACTUAL BACKGROUND**

### ***Boston Dynamics' Early and Continued Innovations***

8. Boston Dynamics is a robotics design company founded in 1992 as a spin-off from the Massachusetts Institute of Technology. Its focus has been and continues to be “on creating robots with advanced mobility, dexterity and intelligence.”<sup>1</sup> Boston Dynamics' robots are inspired by the natural world to be able to balance and to have dynamic motion; this allows many Boston Dynamics robots to “navigate tough unstructured, unknown or antagonistic terrain with ease.”<sup>2</sup> To this effort, Boston Dynamics has invested millions of dollars in the development of its robots.

9. Boston Dynamics began developing and launching its first quadrupedal robots as early as 2005—the first robot called BigDog served as a robotic pack mule for rough terrain. Following BigDog, Boston Dynamics has continued to develop robots from 2005 to the present. Other Boston Dynamics projects include, but are not limited to, the Cheetah, LittleDog, PETMAN, LS3, Atlas, Spot®, Handle, Stretch, Wildcat, Sandflea, RHex, RiSE, and Pick.

---

<sup>1</sup> BOSTON DYNAMICS, <https://www.bostondynamics.com/about> (last visited Feb. 8, 2024).

<sup>2</sup> *Id.*

10. Boston Dynamics introduced the Spot® robot, an innovative four-legged robot designed for industrial and commercial applications. At the time, the Spot® robot was the quietest and most capable robot Boston Dynamics had ever built. Boston Dynamics' Spot® robot was honored by the Robotics Business Review Innovation Awards in 2020, 2021, and 2022 for its innovation.<sup>3</sup>

### ***The Asserted Patents***

11. Boston Dynamics, with its early roots in the robotics industry, has been and continues to be a pioneer and leading innovator in developing quadrupedal and bipedal robots. The Asserted Patents discussed below capture technology, features, and processes that reflect these innovations.

12. On March 14, 2017, the United States Patent and Trademark Office (“the USPTO”) duly and legally issued U.S. Patent No. 9,594,377 (the “’377 patent”), titled “Auto-Height Swing Adjustment.” Boston Dynamics is the owner by assignment of the ’377 patent. The application for the ’377 patent was filed with the USPTO on May 12, 2015. A true and accurate copy of the ’377 patent is attached here as Exhibit A.

13. On March 6, 2018, the USPTO duly and legally issued U.S. Patent No. 9,908,240 (the “’240 patent”), titled “Ground Plane Compensation for Legged Robots.” Boston Dynamics is the owner by assignment of the ’240 patent. The application for the ’240 patent was filed with

---

<sup>3</sup> *Boston Dynamics Hopes to Kick-Start Commercial Quadruped Market*, ROBOTICS BUSINESS REVIEW, <https://www.roboticsbusinessreview.com/rbr50-company/boston-dynamics-commercializes-spot-quadruped-robot/>; *Robot Arm Opens Doors for Boston Dynamics' Spot Quadruped*, ROBOTICS BUSINESS REVIEW, <https://www.roboticsbusinessreview.com/rbr50-company-2021/boston-dynamics/>; *Boston Dynamics' Spot Enterprise Goes the Distance*, ROBOTICS BUSINESS REVIEW, <https://www.roboticsbusinessreview.com/rbr50-company-2022/spot-enterprise-brings-the-quadruped-to-new-places/>.

the USPTO on December 21, 2016. A true and accurate copy of the '240 patent is attached here as Exhibit B.

14. On October 17, 2017, the USPTO duly and legally issued U.S. Patent No. 9,789,611 (the "'611 patent"), titled "Handling Gait Disturbances with Asynchronous Timing." Boston Dynamics is the owner by assignment of the '611 patent. The application for the '611 patent was filed with the USPTO on June 22, 2016. A true and accurate copy of the '611 patent is attached here as Exhibit C.

15. On March 29, 2022, the USPTO duly and legally issued U.S. Patent No. 11,287,819 (the "'819 patent"), titled "System and Methods for Ground Plane Estimation." Boston Dynamics is the owner by assignment of the '819 patent. The application for the '819 patent was filed with the USPTO on October 8, 2019. A true and accurate copy of the '819 patent is attached here as Exhibit D.

16. On September 12, 2023, the USPTO duly and legally issued U.S. Patent No. 11,752,645 (the "'645 patent"), titled "Non-Planar Linear Actuator." Boston Dynamics is the owner by assignment of the '645 patent. The application for the '645 patent was filed with the USPTO on February 13, 2020. A true and accurate copy of the '645 patent is attached here as Exhibit M.

***Defendant's Accused Products***

17. Upon information and belief, in or around 2019, Defendant introduced a product called the Vision 60. On information and belief, Defendant makes, uses, offers to sell, and/or sells the Vision 60 in the United States, and/or imports the Vision 60 into the United States. Provided herewith as Exhibit E is a copy of the Vision 60 website at <https://www.ghostrobotics.io/vision-60> (last visited Feb. 8, 2024); and provided herewith as Exhibit F is a copy of the Vision 60

information sheet at <https://farrwest.com/pub/media/pdf/Hero%20Products/Vision60/GRV60QUGV.pdf>.

18. Upon information and belief, in or around 2020, Defendant introduced a product called the Spirit 40 product. On information and belief, Defendant makes, uses, offers to sell, and/or sells the Spirit 40 product in the United States, and/or imports the Spirit 40 product into the United States. Provided herewith as Exhibit G is a copy of the Spirit 40 product information sheet at [https://uspto.report/ts/cd/pdfs?f=/SOU/2020/06/23/20200623125618914893-88276426-004\\_003/SPN1-3898152106-20200623124743387022\\_.\\_GR\\_Spirit\\_40-P\\_Quad\\_UGV-\\_Full\\_Spec\\_rev1.0.pdf](https://uspto.report/ts/cd/pdfs?f=/SOU/2020/06/23/20200623125618914893-88276426-004_003/SPN1-3898152106-20200623124743387022_._GR_Spirit_40-P_Quad_UGV-_Full_Spec_rev1.0.pdf).

19. Upon learning that Defendant might have entered the market and released products that it believed might practice its intellectual property, on July 7, 2020, Boston Dynamics wrote to Defendant requesting that Defendant review Boston Dynamics' published patent applications and issued patents to ensure that Ghost Robotics did not infringe Boston Dynamics' patent rights, particularly referencing the Ghost Robotics Vision 60.

20. On March 1, 2021, Boston Dynamics sent a cease and desist letter to Defendant requesting that it stop marketing robots and technology that Boston Dynamics believed infringe Boston Dynamics' intellectual property. In that letter, Boston Dynamics identified the '377, '240, and '611 patents, among others, and again referenced the Ghost Robotics Vision 60.

21. On May 9, 2022, Boston Dynamics sent Defendant another cease and desist letter, specifically calling out the similarities in morphology and operation between Ghost Robotics' quadrupedal robots (particularly the Vision 60) and Boston Dynamics' Spot® robot. Some of the similarities between the Ghost Robotics Vision 60 and Boston Dynamics Spot® robot are illustrated in the images below (Plaintiff's images on the left and Defendant's on the right):

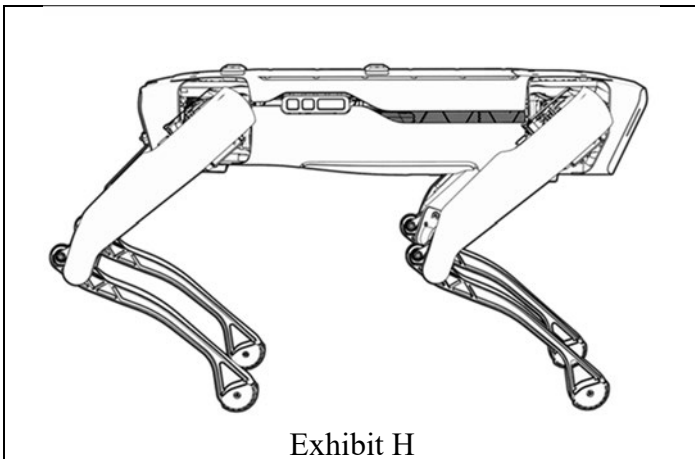

Exhibit H

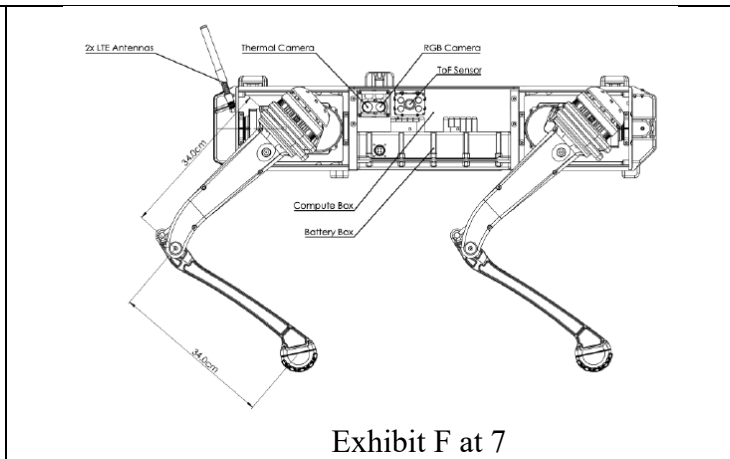

Exhibit F at 7

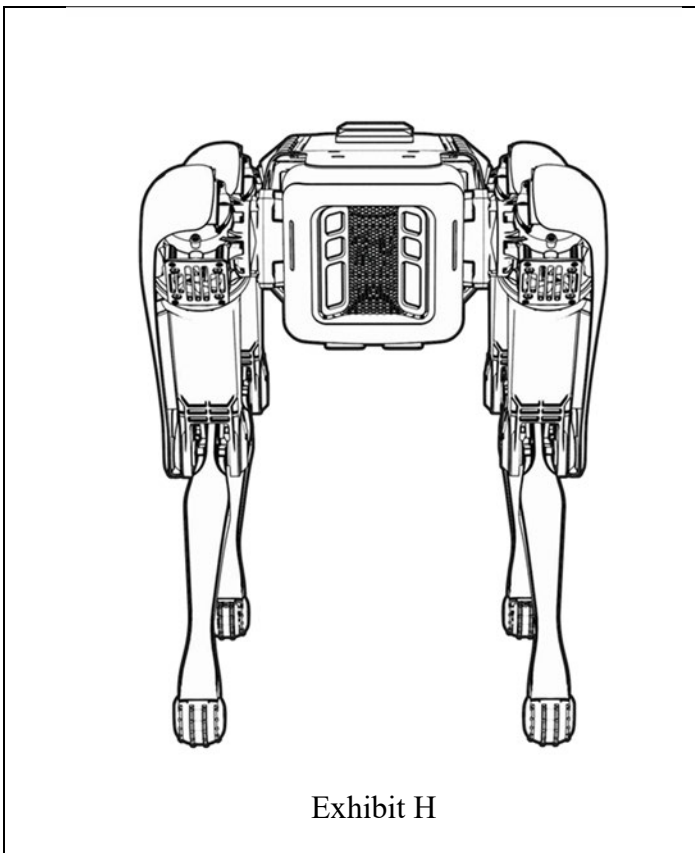

Exhibit H

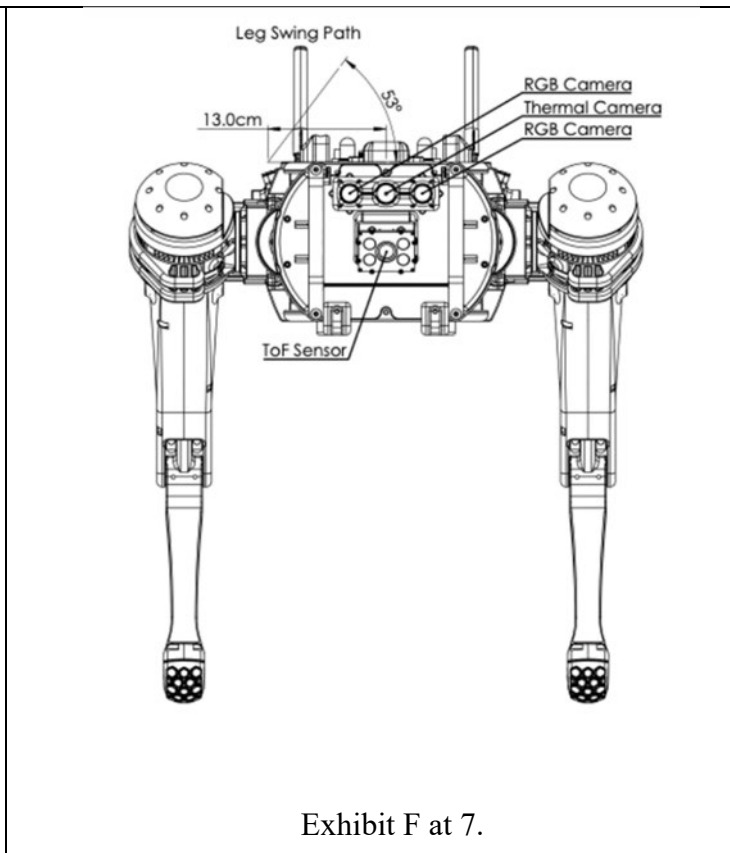

Exhibit F at 7.



Exhibit I



Exhibit J

22. In that May 9, 2022 letter, Boston Dynamics again identified the '377, '240, and '611 patents, among others.

23. On November 11, 2022, Boston Dynamics filed a lawsuit against Ghost Robotics in the District of Delaware (C.A. No. 22-1483) alleging Ghost Robotics has infringed and continues to infringe the following Boston Dynamics' patents: U.S. Patent Nos. 9,308,648, 9,662,791, 11,123,869, 9,387,588, 11,073,842, 10,253,855, and 11,131,368.

**COUNT I—INFRINGEMENT OF THE '377 PATENT**

24. The allegations in the preceding paragraphs are incorporated by reference as if fully set forth herein.

25. Defendant has directly infringed, and continues to directly infringe, at least claim 1 of the '377 patent by making, using, offering for sale, selling, and/or importing into the United States the Vision 60 and Spirit 40 products, and has induced and contributed to the infringement of the '377 patent by others.

26. For example, and without limitation, on information and belief, the Vision 60 and Spirit 40 products meet every limitation of at least independent claim 1 of the '377 patent, and Defendant's making, using, offering for sale, selling, and/or importing into the United States the Vision 60 and Spirit 40 products directly infringes claim 1 of the '377 patent under 35 U.S.C. § 271(a).

27. Claim 1 of the '377 patent recites:

1. A control system comprising:

one or more processors;

a non-transitory computer readable medium; and

program instructions stored on the non-transitory computer readable medium and executable by the one or more processors to:

receive, from a robotic device, sensor data that indicates topographical features of an environment in which the robotic device is operating;

process the sensor data into a topographical map that includes a two-dimensional matrix of cells, the cells indicating sample heights of respective portions of the environment;

determine, for a first foot of the robotic device, a first pre-planned step path extending from a first lift-off location to a first touch-down location;

identify, within the topographical map, a first scan patch of cells that encompass the first pre-planned step path;

determine that a first high point among the first scan patch of cells is greater than a threshold obstacle height; and

during a first step corresponding to the first pre-planned step path, cause the robotic device to lift the first foot to a first swing height that is higher than the determined first high point.

28. The Vision 60 is comprised of a control system. For example, Defendant's product information states that the Vision 60 has "Ghost OS and Robot Software[--] Comprehensive, low-



level core control to higher application development environment and APIs, simulation, diagnostic tools, and applications.” Ex. F at 5.

29. The Vision 60 is comprised of at least one or more processors. For example, Defendant’s product information identifies that the Vision 60 has a “NVIDIA Xavier CPU/GPU.” Exhibit F at 6.

30. The Vision 60 is comprised of a non-transitory computer readable medium. For example, Defendant’s product information identifies that the Vision 60 has “Ghost OS and Robot Software[–] Comprehensive, low-level core control to higher application development environment and APIs, simulation, diagnostic tools, and applications.” Exhibit F at 5.

31. The Vision 60 is comprised of program instructions stored on the non-transitory computer readable medium and executable by the one or more processors. For example, Defendant’s product information identifies that the Vision 60 contains a “Ghost SDK” that is able to implement or execute “Low-Level API (Behavior)” and “High-Level API (Applications).” Exhibit F at 5.

32. The Vision 60 is capable of receiving, from a robotic device, sensor data that indicates topographical features of an environment in which the robotic device is operating. The Vision 60 is also capable of processing the sensor data into a topographical map that includes a two-dimensional matrix of cells, the cells indicating sample heights of respective portions of the environment. For example, Defendant’s product information identifies that the Vision 60 contains “Operational & Task Sensors,” including but not limited to a ToF sensor, that are used to “[m]inimize[] collision risk with environmental objects under autonomous or tele-operation including stairclimbing mode.” Exhibit F at 5, 6. On information and belief, the ToF sensor is an

“Intel 435 depth sensor that lets it map the ground plane,” Exhibit K, and is located in the following illustration of the Vision 60:<sup>4</sup>

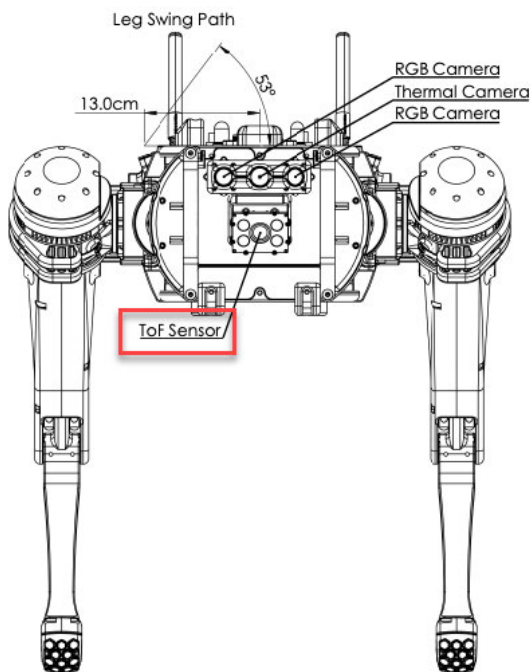

33. The Vision 60 is capable of determining, for a first foot of the robotic device, a first pre-planned step path extending from a first lift-off location to a first touch-down location. For example, as the Vision 60 approaches a raised surface, the Vision 60 is able to plan a step path that includes where to lift-off and where to touch-down.<sup>5</sup>

---

<sup>4</sup> Exhibit F at 7.

<sup>5</sup> *Ghost Robotics*, GHOST ROBOTICS (Nov. 13, 2023 at 3:49 PM EST), available at <https://vimeo.com/884142292> at 2:59-3:01.

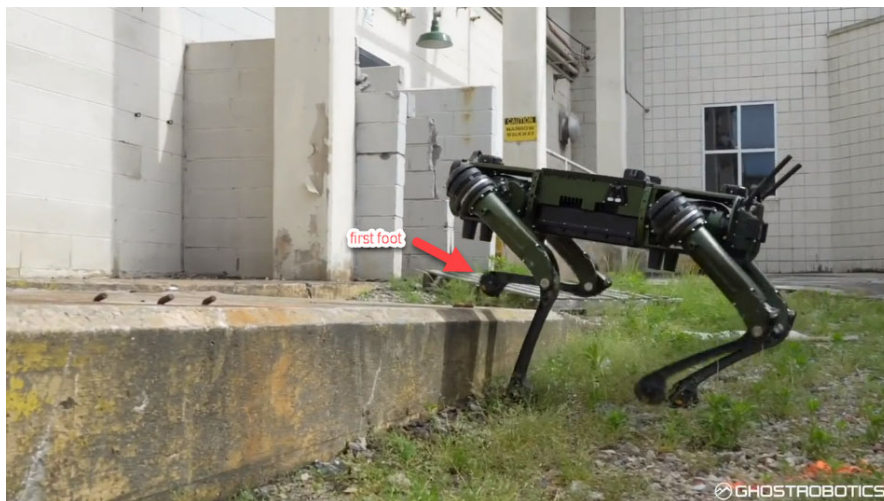

34. The Vision 60 is capable of identifying, within the topographical map, a first scan patch of cells that encompass the first pre-planned step path. For example, in planning the step path, the Vision 60 is able to detect a raised surface that will affect the step path of the first foot:<sup>6</sup>

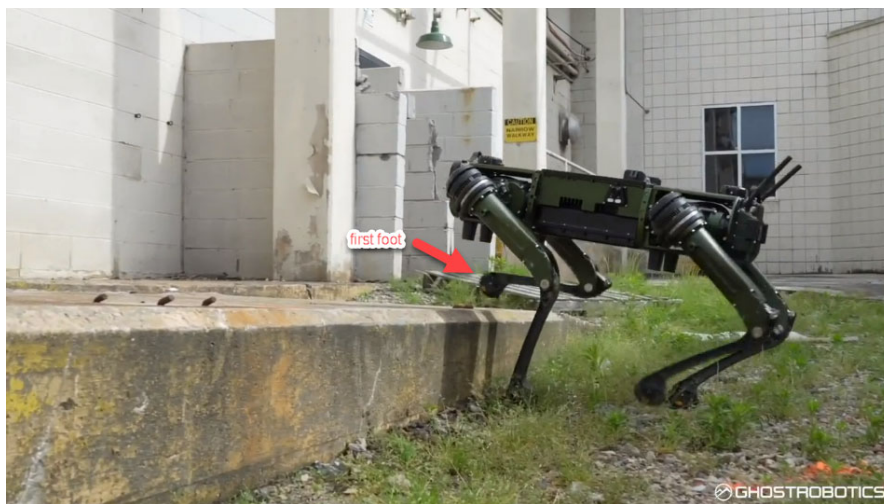

35. The Vision 60 is capable of determining that a first high point among the first scan patch of cells is greater than a threshold obstacle height. For example, the Vision 60 is able to

---

<sup>6</sup> Ghost Robotics, GHOST ROBOTICS (Nov. 13, 2023 at 3:49 PM EST), available at <https://vimeo.com/884142292> at 2:59-3:01.

determine the height of the forthcoming raised surface and what is the minimum height that the first foot needs to be raised:<sup>7</sup>

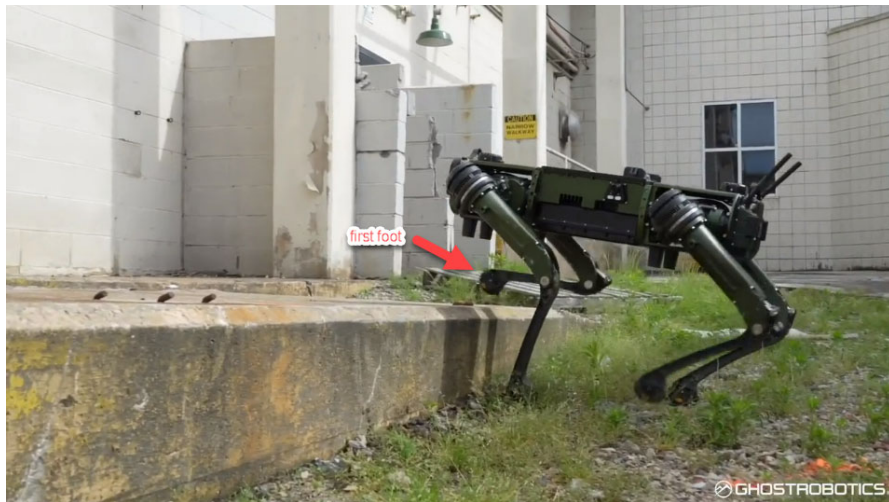

36. The Vision 60 is capable of during a first step corresponding to the first pre-planned step path, cause the robotic device to lift the first foot to a first swing height that is higher than the determined first high point. For example, the Vision 60 is able to swing the first foot to be higher than the minimum height needed to step onto the raised surface:<sup>8</sup>

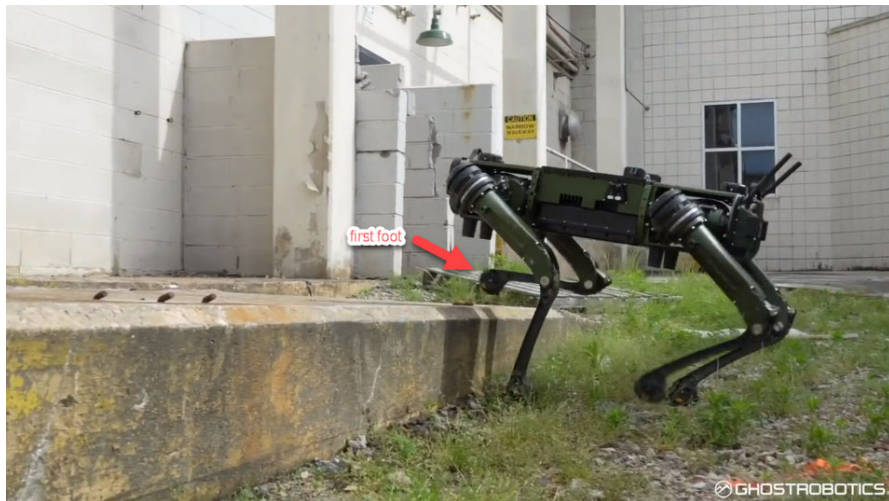

---

<sup>7</sup> *Ghost Robotics*, GHOST ROBOTICS (Nov. 13, 2023 at 3:49 PM EST), available at <https://vimeo.com/884142292> at 2:59-3:01.

<sup>8</sup> *Ghost Robotics*, GHOST ROBOTICS (Nov. 13, 2023 at 3:49 PM EST), available at <https://vimeo.com/884142292> at 2:59-3:01.



37. On information and belief, the Spirit 40 product has these same capabilities as the Vision 60, because the Spirit 40 and the Vision 60 share the same software. For example, Defendant's product information states that the Spirit 40 product is "**The Ultimate Research Robot.** Built on same software, SDK and electronics as the Vision and Wraith series Q-UGVs for enterprise and military." Exhibit G at 1. Thus, like the Vision 60, the Spirit 40 product similarly infringes at least claim 1 of the '377 patent.

38. Defendant has indirectly infringed and continues to indirectly infringe the claims of the '377 patent by inducing infringement pursuant to 35 U.S.C. § 271(b) and contributing to infringement pursuant to 35 U.S.C. § 271(c).

39. On information and belief, in violation of 35 U.S.C. § 271(b), Defendant specifically intended to induce infringement of the '377 patent by its customers and users of the Vision 60 and Spirit 40 products and had knowledge that the inducing acts would cause infringement or was willfully blind to the possibility that their inducing acts would cause infringement.

40. Defendant has known of the '377 patent since at least as early as March 1, 2021, when Boston Dynamics notified Defendant of that patent. Boston Dynamics notified Defendant

of the '377 patent again on May 9, 2022. Defendant also knew or should have known of the '377 patent because Boston Dynamics cites the patent on its website and marks its Spot® robot with the number of that patent (*see* <https://www.bostondynamics.com/patents> (last visited Feb. 8, 2024)).

41. On information and belief, Defendant's customers directly infringe the '377 patent. For example, when the Vision 60 and Spirit 40 products are sold to customers, those customers infringe at least independent claim 1 of the '377 patent through their use of the Vision 60 and Spirit 40 products.

42. On information and belief, Defendant specifically intends that its customers infringe the '377 patent. Defendant encourages infringement by customers at least by providing product support instructing users on how to use the Vision 60 and Spirit 40 products. For example, Defendant provides specification sheets. Exs. F, G. The specification sheets describe the features of the Vision 60 and Spirit 40 products, including “[t]ravers[ing] unstructured terrain,” climbing stairs, and “[s]afeguard [a]voidance.” Exhibit F at 5; Exhibit G at 3. As another example, Defendant provides support to its customers. Exhibit L at 1.

43. On information and belief, despite Defendant's knowledge of the '377 patent and knowledge that customers will necessarily infringe the '377 patent when the Vision 60 and Spirit 40 products are used as instructed, Defendant continues to encourage infringement.

44. Defendant also contributes to infringement of the '377 patent by Defendant's customers in violation of 35 U.S.C. § 271(c). On information and belief, Defendant offers to sell and sells within the United States the Vision 60 and Spirit 40 products knowing that they are especially made or especially adapted for use in infringing the '377 patent, and knowing that the

Vision 60 and Spirit 40 products are not staple articles or commodities of commerce suitable for substantial non-infringing use.

45. Defendant has committed and continues to commit all of the above acts of infringement without license or authorization.

46. Boston Dynamics has complied with the requirements of 35 U.S.C. § 287 by, among other things, marking its products with the number of the '377 patent, and giving actual notice to Defendant no later than March 1, 2021 and again no later than May 9, 2022. Defendant also knew or should have known of the '377 patent because Boston Dynamics cites the patent on its website (*see* <https://www.bostondynamics.com/patents> (last visited Feb. 8, 2024)).

47. As a result of Defendant's infringement of the '377 patent, Plaintiff has suffered damages and will continue to suffer damages.

48. On information and belief, the infringement of the '377 patent by Defendant has been and continues to be willful. Defendant has had knowledge of the '377 patent and knowledge that the Vision 60 is covered by the '377 patent since at least March 1, 2021, and Boston Dynamics notified Defendant of the '377 patent again on May 9, 2022. Defendant also knew or should have known of the '377 patent because Boston Dynamics cites the patent on its website (*see* <https://www.bostondynamics.com/patents> (last visited Feb. 8, 2024)).

49. Defendant has thus sold the Vision 60 knowing of the risk of infringement and/or in view of a risk of infringement that was sufficiently obvious that it should have been known to Defendant. Despite this risk, Defendant has deliberately continued to infringe in a wanton, malicious, and egregious manner, with reckless disregard for Boston Dynamics' patent rights. Thus, Defendant's infringing actions have been and continue to be knowingly wrongful, entitling Boston Dynamics to increased damages under 35 U.S.C. § 284.

50. Under 35 U.S.C. § 283, Boston Dynamics is entitled to a permanent injunction against further infringement. Defendant's wrongful conduct has caused and will continue to cause Boston Dynamics to suffer irreparable harm resulting from the loss of its lawful patent right to exclude others from making, using, selling, offering for sale, and/or importing Boston Dynamics' patented inventions. On information and belief, Defendant will continue to infringe the '377 patent unless permanently enjoined by the Court.

### **COUNT II—INFRINGEMENT OF THE '240 PATENT**

51. The allegations in the preceding paragraphs are incorporated by reference as if fully set forth herein.

52. Defendant has directly infringed, and continues to directly infringe, at least claim 1 of the '240 patent by making, using, offering for sale, selling, and/or importing into the United States the Vision 60 and Spirit 40 products, and has induced and contributed to the infringement of the '240 patent by others.

53. For example, and without limitation, on information and belief, the Vision 60 and Spirit 40 products meet every limitation of at least independent claim 1 of the '240 patent, and Defendant's making, using, offering for sale, selling, and/or importing into the United States the Vision 60 and Spirit 40 products directly infringes claim 1 of the '240 patent under 35 U.S.C. § 271(a).

54. Claim 1 of the '240 patent recites:

1. A control system of a robot comprising:

a processor in communication with at least one sensor; and

a non-transitory computer readable medium in communication with the processor, the non-transitory computer readable medium storing program instructions that when executed on the processor cause the processor to perform operations comprising:



determining, using sensor data obtained from the at least one sensor, a height of a particular topographical feature in a direction of travel of the robot and a distance between the robot and the particular topographical feature;

estimating a plane extending from the robot in the direction of travel toward the particular topographical feature, the estimated plane having a slope based on the height of the particular topographical feature and the distance between the robot and the particular topographical feature;

determining whether the slope of the estimated plane comprises a positive slope or a negative slope; and

when the slope of the estimated plane comprises the positive slope, controlling actuators of the robot to cause the robot to pitch a torso of the robot in the direction of travel of the robot.

55. The Vision 60 is comprised of a control system of robot. For example, Defendant's product information states that the Vision 60 has "Ghost OS and Robot Software[--] Comprehensive, low-level core control to higher application development environment and APIs, simulation, diagnostic tools, and applications." Exhibit F at 5.

56. The Vision 60 is comprised of a processor in communication with at least one sensor. For example, Defendant's product information identifies that the Vision 60 has a "NVIDIA Xavier CPU/GPU." Exhibit F at 6. In addition, Defendant's product information identifies that the Vision 60 contains "Operational & Task Sensors," including but not limited to a ToF sensor, that are used to "[m]inimize[] collision risk with environmental objects under autonomous or tele-operation including stairclimbing mode." Exhibit F at 5, 6. On information and belief, the ToF sensor is an "Intel 435 depth sensor that lets it map the ground plane," Exhibit K, and is located in the following illustration of the Vision 60:<sup>9</sup>

---

<sup>9</sup> Exhibit F at 7.

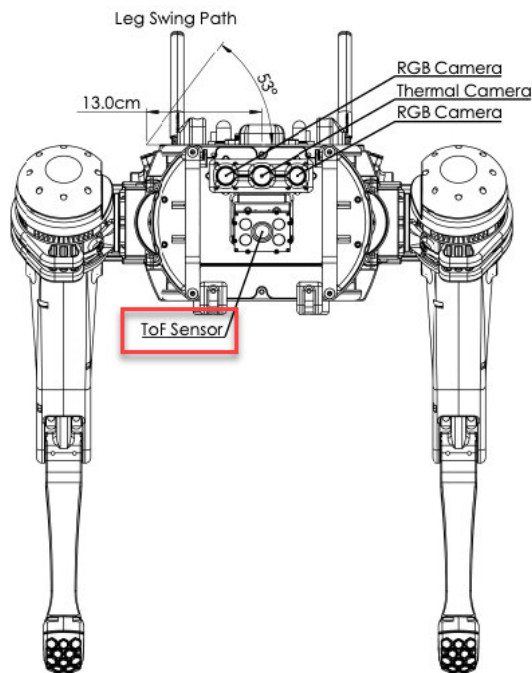

57. The Vision 60 is comprised of a non-transitory computer readable medium in communication with the processor, the non-transitory computer readable medium storing program instructions that when executed on the processor cause the processor to perform operations. For example, Defendant's product information identifies that the Vision 60 has "Ghost OS and Robot Software[--] Comprehensive, low-level core control to higher application development environment and APIs, simulation, diagnostic tools, and applications." Exhibit F at 5. In addition, Defendant's product information identifies that the Vision 60 contains a "Ghost SDK" that is able to implement or execute "Low-Level API (Behavior)" and "High-Level API (Applications)." Exhibit F at 5.

58. The Vision 60 is capable of determining, using sensor data obtained from the at least one sensor, a height of a particular topographical feature in a direction of travel of the robot and a distance between the robot and the particular topographical feature. For example, Defendant's product information identifies that the Vision 60 contains "Operational & Task

Sensors,” including but not limited to a ToF sensor, that are used to “[m]inimize[] collision risk with environmental objects under autonomous or tele-operation including stairclimbing mode.” Exhibit F at 5, 6. On information and belief, the ToF sensor is an “Intel 435 depth sensor that lets it map the ground plane,” Exhibit K, and is located in the following illustration of the Vision 60:<sup>10</sup>

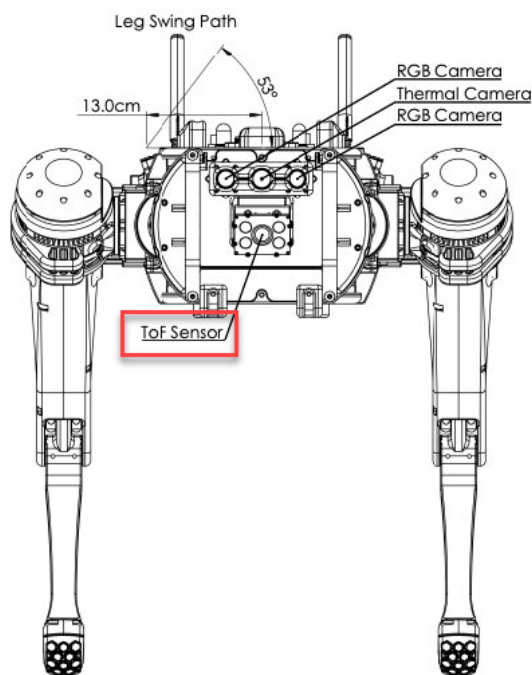

59. The Vision 60 is capable of estimating a plane extending from the robot in the direction of travel toward the particular topographical feature, the estimated plane having a slope based on the height of the particular topographical feature and the distance between the robot and the particular topographical feature. For example, the Vision 60 is able to detect the plane of a raised surface relative to its current position based on the distance and height of the raised surface prior to stepping down on the raised surface:<sup>11</sup>

<sup>10</sup> Exhibit F at 7.

<sup>11</sup> *Ghost Robotics*, GHOST ROBOTICS (Nov. 13, 2023 at 3:49 PM EST), available at <https://vimeo.com/884142292> at 2:59-3:01.



60. The Vision 60 is capable of determining whether the slope of the estimated plane comprises a positive slope or a negative slope. For example, the Vision 60 is able to determine whether the oncoming surface is on a positive or negative slope relative to its current position:<sup>12</sup>

---

<sup>12</sup> Ghost Robotics, *Perception-Based Stair Climbing & Obstacle Management*, YouTube (July 23, 2020), [https://www.youtube.com/watch?v=5sE\\_zssS4EQ](https://www.youtube.com/watch?v=5sE_zssS4EQ) at 0:00-0:40; Ghost Robotics, GHOST ROBOTICS (Nov. 13, 2023 at 3:49 PM EST), available at <https://vimeo.com/884142292> at 1:39-1:45, 2:36-2:41.

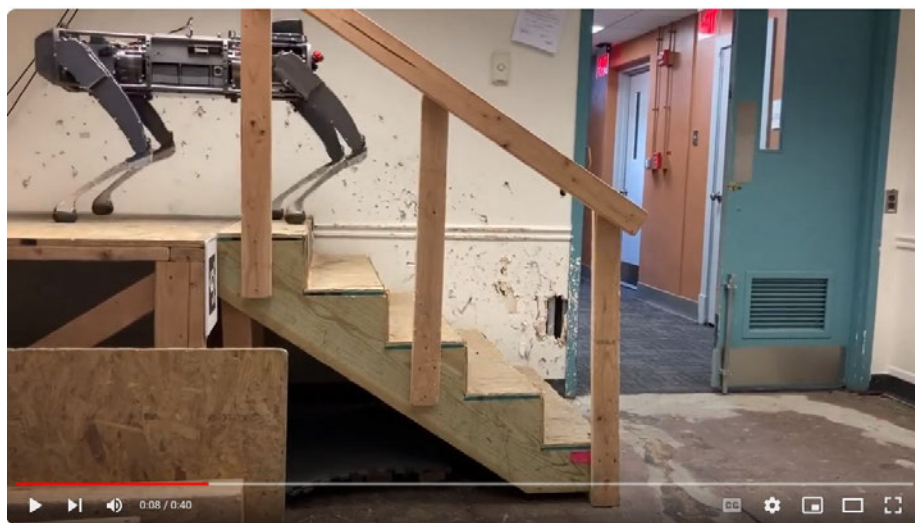
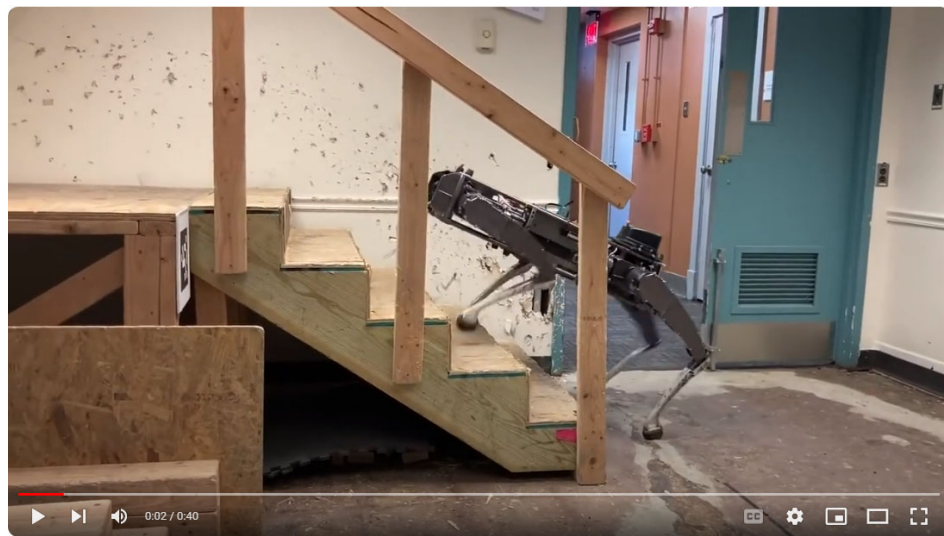
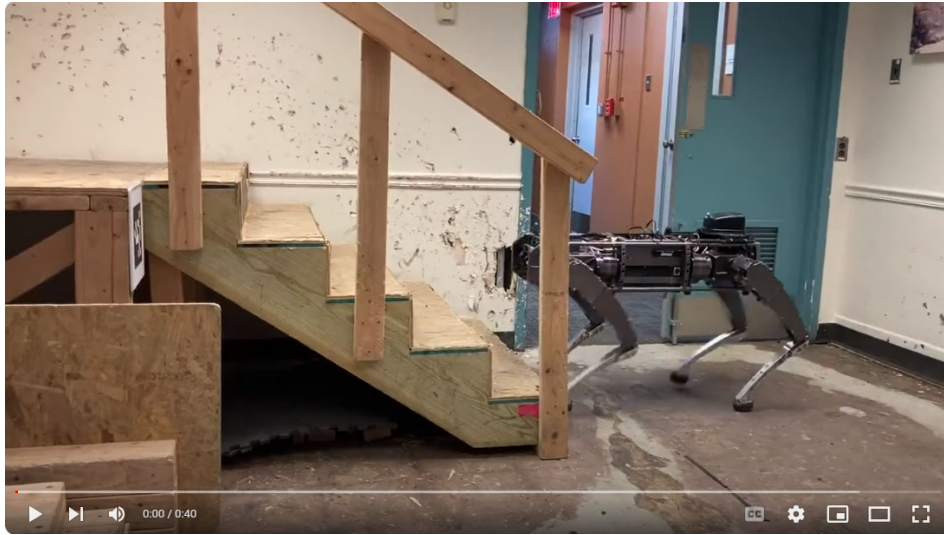



61. The Vision 60 is capable of when the slope of the estimated plane comprises the positive slope, controlling actuators of the robot to cause the robot to pitch a torso of the robot in the direction of travel of the robot. For example, the Vision 60 is able to adjust the pitch of its torso to be substantially parallel to the positive slope of the surface that it is climbing.<sup>13</sup>



<sup>13</sup> Ghost Robotics, *Perception-Based Stair Climbing & Obstacle Management*, YouTube (July 23, 2020), [https://www.youtube.com/watch?v=5sE\\_zssS4EQ](https://www.youtube.com/watch?v=5sE_zssS4EQ) at 0:00-0:40; Ghost Robotics, *GHOST ROBOTICS* (Nov. 13, 2023 at 3:49 PM EST), available at <https://vimeo.com/884142292> at 1:46-1:50.

62. On information and belief, the Spirit 40 product has these same capabilities as the Vision 60, because the Spirit 40 and the Vision 60 share the same software. For example, Defendant's product information states that the Spirit 40 product is "**The Ultimate Research Robot**. Built on same software, SDK and electronics as the Vision and Wraith series Q-UGVs for enterprise and military." Exhibit G at 1. Thus, like the Vision 60, the Spirit 40 product similarly infringes at least claim 1 of the '240 patent.

63. Defendant has indirectly infringed and continues to indirectly infringe the claims of the '240 patent by inducing infringement pursuant to 35 U.S.C. § 271(b) and contributing to infringement pursuant to 35 U.S.C. § 271(c).

64. On information and belief, in violation of 35 U.S.C. § 271(b), Defendant specifically intended to induce infringement of the '240 patent by its customers and users of the Vision 60 and Spirit 40 products and had knowledge that the inducing acts would cause infringement or was willfully blind to the possibility that their inducing acts would cause infringement.

65. Defendant has known of the '240 patent since at least as early as March 1, 2021, when Boston Dynamics notified Defendant of that patent. Boston Dynamics notified Defendant of the '240 patent again on May 9, 2022. Defendant also knew or should have known of the '240 patent because Boston Dynamics cites the patent on its website and marks its Spot® robot with the number of that patent (*see* <https://www.bostondynamics.com/patents> (last visited Feb. 8, 2024)).

66. On information and belief, Defendant's customers directly infringe the '240 patent. For example, when the Vision 60 and Spirit 40 products are sold to customers, those customers



infringe at least independent claim 1 of the '240 patent through their use of the Vision 60 and Spirit 40 products.

67. On information and belief, Defendant specifically intends that its customers infringe the '240 patent. Defendant encourages infringement by customers at least by providing product support instructing users on how to use the Vision 60 and Spirit 40 products. For example, Defendant provides specification sheets. Exs. F, G. The specification sheets describe the features of the Vision 60 and Spirit 40 products, including “[t]ravers[ing] unstructured terrain,” climbing stairs, and “[s]afeguard [a]voidance.” Exhibit F at 5; Exhibit G at 3. As another example, Defendant provides support to its customers. Exhibit L at 1.

68. On information and belief, despite Defendant’s knowledge of the '240 patent and knowledge that customers will necessarily infringe the '240 patent when the Vision 60 and Spirit 40 products are used as instructed, Defendant continues to encourage infringement.

69. Defendant also contributes to infringement of the '240 patent by Defendant’s customers in violation of 35 U.S.C. § 271(c). On information and belief, Defendant offers to sell and sells within the United States the Vision 60 and Spirit 40 products knowing that they are especially made or especially adapted for use in infringing the '240 patent, and knowing that the Vision 60 and Spirit 40 products are not staple articles or commodities of commerce suitable for substantial non-infringing use.

70. Defendant has committed and continues to commit all of the above acts of infringement without license or authorization.

71. Boston Dynamics has complied with the requirements of 35 U.S.C. § 287 by, among other things, marking its products with the number of the '240 patent, and giving actual notice to Defendant no later than March 1, 2021 and again no later than May 9, 2022. Defendant

also knew or should have known of the '240 patent because Boston Dynamics cites the patent on its website (*see* <https://www.bostondynamics.com/patents> (last visited Feb. 8, 2024)).

72. As a result of Defendant's infringement of the '240 patent, Plaintiff has suffered damages and will continue to suffer damages.

73. On information and belief, the infringement of the '240 patent by Defendant has been and continues to be willful. Defendant has had knowledge of the '240 patent and knowledge that the Vision 60 is covered by the '240 patent since at least March 1, 2021, and Boston Dynamics notified Defendant of the '240 patent again on May 9, 2022. Defendant also knew or should have known of the '240 patent because Boston Dynamics cites the patent on its website (*see* <https://www.bostondynamics.com/patents> (last visited Feb. 8, 2024)).

74. Defendant has thus sold the Vision 60 knowing of the risk of infringement and/or in view of a risk of infringement that was sufficiently obvious that it should have been known to Defendant. Despite this risk, Defendant has deliberately continued to infringe in a wanton, malicious, and egregious manner, with reckless disregard for Boston Dynamics' patent rights. Thus, Defendant's infringing actions have been and continue to be knowingly wrongful, entitling Boston Dynamics to increased damages under 35 U.S.C. § 284.

75. Under 35 U.S.C. § 283, Boston Dynamics is entitled to a permanent injunction against further infringement. Defendant's wrongful conduct has caused and will continue to cause Boston Dynamics to suffer irreparable harm resulting from the loss of its lawful patent right to exclude others from making, using, selling, offering for sale, and/or importing Boston Dynamics' patented inventions. On information and belief, Defendant will continue to infringe the '240 patent unless permanently enjoined by the Court.

**COUNT III—INFRINGEMENT OF THE '611 PATENT**

76. The allegations in the preceding paragraphs are incorporated by reference as if fully set forth herein.

77. Defendant has directly infringed, and continues to directly infringe, at least claim 8 of the '611 patent by making, using, offering for sale, selling, and/or importing into the United States the Vision 60 and Spirit 40 products, and has induced and contributed to the infringement of the '611 patent by others.

78. For example, and without limitation, on information and belief, the Vision 60 and Spirit 40 products meet every limitation of at least independent claim 8 of the '611 patent, and Defendant's making, using, offering for sale, selling, and/or importing into the United States of the Vision 60 and Spirit 40 products directly infringes claim 8 of the '611 patent under 35 U.S.C. § 271(a).

79. Claim 8 of the '611 patent recites:

8. A robot comprising:

a first leg connected to a first foot;

a second leg connected to a second foot;

a processor;

a non-transitory computer readable medium; and

program instructions stored on the non-transitory computer readable medium that, when executed by the processor, cause the robot to perform functions comprising:

causing the first foot to swing forward on a target swing trajectory;

after causing the first foot to swing forward on the target swing trajectory, causing the first foot to begin to step down to a surface;

after causing the first foot to begin to step down to the surface, detecting an indication that at least one joint of the first leg has reached a range of motion limit before the first foot has contacted the surface; and

in response to detecting the indication that the at least one joint has reached the range of motion limit before the first foot has contacted the surface, causing the second leg to reduce a ground reaction force on the second foot in contact with the surface to lower the first foot to the surface.

80. The Vision 60 is comprised of a robot for the reasons discussed below.

81. The Vision 60 is comprised of a first leg connected to a first foot and a second leg connected to a second foot. For example, the Vision 60 robot has at least two legs each connected to a foot:<sup>14</sup>



82. The Vision 60 is comprised of a processor and a non-transitory computer readable medium. For example, Defendant’s product information identifies that the Vision 60 has a “NVIDIA Xavier CPU/GPU.” Exhibit F at 6. Defendant’s product information also identifies that the Vision 60 has “Ghost OS and Robot Software[–] Comprehensive, low-level core control to higher application development environment and APIs, simulation, diagnostic tools, and applications” and a “Ghost SDK” that is able to implement or execute “Low-Level API (Behavior)” and “High-Level API (Applications).” Exhibit F at 5.

---

<sup>14</sup> Sam Eckholm, *Robotic Ghost Dog | The Future of Military Security?*, YOUTUBE (May 1, 2021), <https://www.youtube.com/watch?v=3UBIQVB7vYI> at 3:58-3:59.

83. The Vision 60 is comprised of program instructions stored on the non-transitory computer readable medium that, when executed by the processor, cause the robot to perform functions comprising causing the first foot to swing forward on a target swing trajectory. For example, the Vision 60 has a first foot that swings forward on a target swing trajectory during a swing state:<sup>15</sup>



<sup>15</sup> Sam Eckholm, *Robotic Ghost Dog | The Future of Military Security?*, YOUTUBE (May 1, 2021), <https://www.youtube.com/watch?v=3UBIQVB7vYI> at 3:58-3:59.

84. The Vision 60 is capable of after causing the first foot to swing forward on the target swing trajectory, causing the first foot to begin to step down to a surface. For example, the Vision 60 enters the step down state after performing the swing state:<sup>16</sup>



85. The Vision 60 is capable of after causing the first foot to begin to step down to the surface, detecting an indication that at least one joint of the first leg has reached a range of motion

---

<sup>16</sup> Sam Eckholm, *Robotic Ghost Dog | The Future of Military Security?*, YOUTUBE (May 1, 2021), <https://www.youtube.com/watch?v=3UBIQVB7vYI> at 3:58-3:59.

limit before the first foot has contacted the surface. For example, the Vision 60 can detect whether the first leg has fully extended and reached its limit before the first foot has made contact with a surface.<sup>17</sup>



86. In addition, the Vision 60 “can, in a sense, literally feel the ground. Every time the feet strike the ground, all its motors will get a current spike, and we can measure that current spike in combination with the onboard IMU to calculate how the robot has struck the ground, what its position is in terms of yaw and pitch, and how it’s doing in balance.” Exhibit K.

87. The Vision 60 is capable of, in response to detecting the indication that the at least one joint has reached the range of motion limit before the first foot has contacted the surface, causing the second leg to reduce a ground reaction force on the second foot in contact with the surface to lower the first foot to the surface. For example, after detecting that the joint in the first

---

<sup>17</sup> *Ghost Robotics*, GHOST ROBOTICS (Nov. 13, 2023 at 3:49 PM EST), available at <https://vimeo.com/884142292> at 2:42-2:50.

leg has not contacted a surface after fully extending, the second leg of the Vision 60 will bend to further lower the first foot so that the first foot can contact the surface.<sup>18</sup>



88. In addition, the Vision 60 “can, in a sense, literally feel the ground. Every time the feet strike the ground, all its motors will get a current spike, and we can measure that current spike

<sup>18</sup> *Ghost Robotics*, GHOST ROBOTICS (Nov. 13, 2023 at 3:49 PM EST), available at <https://vimeo.com/884142292> at 2:42-2:50.



in combination with the onboard IMU to calculate how the robot has struck the ground, what its position is in terms of yaw and pitch, and how it's doing in balance.” Exhibit K.

89. On information and belief, the Spirit 40 product has these same capabilities as the Vision 60, because the Spirit 40 and the Vision 60 share the same software. For example, Defendant's product information states that the Spirit 40 product is “**The Ultimate Research Robot**. Built on same software, SDK and electronics as the Vision and Wraith series Q-UGVs for enterprise and military.” Exhibit G at 1. Thus, like the Vision 60, the Spirit 40 product similarly infringes at least claim 1 of the '611 patent.

90. Defendant has indirectly infringed and continues to indirectly infringe the claims of the '611 patent by inducing infringement pursuant to 35 U.S.C. § 271(b) and contributing to infringement pursuant to 35 U.S.C. § 271(c).

91. On information and belief, in violation of 35 U.S.C. § 271(b), Defendant specifically intended to induce infringement of the '611 patent by its customers and users of the Vision 60 and Spirit 40 products and had knowledge that the inducing acts would cause infringement or was willfully blind to the possibility that their inducing acts would cause infringement.

92. Defendant has known of the '611 patent since at least as early as March 1, 2021, when Boston Dynamics notified Defendant of that patent. Boston Dynamics notified Defendant of the '611 patent again on May 9, 2022. Defendant also knew or should have known of the '611 patent because Boston Dynamics cites the patent on its website and marks its Spot® robot with the number of that patent (*see* <https://www.bostondynamics.com/patents> (last visited Feb. 8, 2024)).

93. On information and belief, Defendant's customers directly infringe the '611 patent. For example, when the Vision 60 and Spirit 40 products are sold to customers, those customers infringe at least independent claim 8 of the '611 patent through their use of the Vision 60 and Spirit 40 products.

94. On information and belief, Defendant specifically intends that its customers infringe the '611 patent. Defendant encourages infringement by customers at least by providing product support instructing users on how to use the Vision 60 and Spirit 40 products. For example, Defendant provides specification sheets. Exs. F, G. The specification sheets describe the features of the Vision 60 and Spirit 40 products, including "[t]ravers[ing] unstructured terrain," climbing stairs, and "[s]afeguard [a]voidance." Exhibit F at 5; Exhibit G at 3. As another example, Defendant provides support to its customers. Exhibit L at 1.

95. On information and belief, despite Defendant's knowledge of the '611 patent and knowledge that customers will necessarily infringe the '611 patent when the Vision 60 and Spirit 40 products are used as instructed, Defendant continues to encourage infringement.

96. Defendant also contributes to infringement of the '611 patent by Defendant's customers in violation of 35 U.S.C. § 271(c). On information and belief, Defendant offers to sell and sells within the United States the Vision 60 and Spirit 40 products knowing that they are especially made or especially adapted for use in infringing the '611 patent, and knowing that the Vision 60 and Spirit 40 products are not staple articles or commodities of commerce suitable for substantial non-infringing use.

97. Defendant has committed and continues to commit all of the above acts of infringement without license or authorization.

98. Boston Dynamics has complied with the requirements of 35 U.S.C. § 287 by, among other things, marking its products with the '611 patent, and giving actual notice to Defendant no later than March 1, 2021 and again no later than May 9, 2022. Defendant also knew or should have known of the '611 patent because Boston Dynamics cites the patent on its website (*see* <https://www.bostondynamics.com/patents> (last visited Feb. 8, 2024)).

99. As a result of Defendant's infringement of the '611 patent, Plaintiff has suffered damages and will continue to suffer damages.

100. On information and belief, the infringement of the '611 patent by Defendant has been and continues to be willful. Defendant has had knowledge of the '611 patent and knowledge that the Vision 60 is covered by the '611 patent since at least March 1, 2021, and Boston Dynamics notified Defendant of the '611 patent again on May 9, 2022. Defendant also knew or should have known of the '611 patent because Boston Dynamics cites the patent on its website (*see* <https://www.bostondynamics.com/patents> (last visited Feb. 8, 2024)).

101. Defendant has thus sold the Vision 60 knowing of the risk of infringement and/or in view of a risk of infringement that was sufficiently obvious that it should have been known to Defendant. Despite this risk, Defendant has deliberately continued to infringe in a wanton, malicious, and egregious manner, with reckless disregard for Boston Dynamics' patent rights. Thus, Defendant's infringing actions have been and continue to be knowingly wrongful, entitling Boston Dynamics to increased damages under 35 U.S.C. § 284.

102. Under 35 U.S.C. § 283, Boston Dynamics is entitled to a permanent injunction against further infringement. Defendant's wrongful conduct has caused and will continue to cause Boston Dynamics to suffer irreparable harm resulting from the loss of its lawful patent right to exclude others from making, using, selling, offering for sale, and/or importing Boston Dynamics'

patented inventions. On information and belief, Defendant will continue to infringe the '611 patent unless permanently enjoined by the Court.

**COUNT IV— INFRINGEMENT OF THE '819 PATENT**

103. The allegations in the preceding paragraphs are incorporated by reference as if fully set forth herein.

104. Defendant has directly infringed, and continues to directly infringe, at least claim 9 of the '819 patent by using and testing in the United States the Vision 60 and Spirit 40 products, and has induced and contributed to the infringement of the '819 patent by others.

105. For example, and without limitation, on information and belief, the Vision 60 and Spirit 40 products meet every limitation of at least independent claim 9 of the '819 patent, and Defendant's making, using, offering for sale, selling, and/or importing into the United States the Vision 60 and Spirit 40 products directly infringes claim 9 of the '819 patent under 35 U.S.C. § 271(a).

106. Claim 9 of the '819 patent recites:

9. A system comprising:

data processing hardware; and

memory hardware in communication with the data processing hardware, the memory hardware storing instructions that when executed on the data processing hardware cause the data processing hardware to perform operations comprising:

receiving a pose of a robotic device with respect to a ground surface;

receiving one or more contact points between the robotic device and the ground surface, each of the one or more contact points derived from sensor information generated by one or more sensors, each sensor of the one or more sensors associated with a respective leg of one or more legs of the robotic device;

determining a ground plane estimation of the ground surface based on the pose of the robotic device with respect to the ground surface and the one

or more contact points between the robotic device and the ground surface;  
and

commanding the robotic device to adjust the pose with respect to the ground surface based on the ground plane estimation.

107. The Vision 60 is comprised of a system for the reasons discussed below.

108. The Vision 60 is comprised of data processing hardware and memory hardware in communication with the data processing hardware, the memory hardware storing instructions that when executed on the data processing hardware cause the data processing hardware to perform operations. For example, Defendant's product information identifies that the Vision 60 has a "NVIDIA Xavier CPU/GPU" and identifies that the Vision 60 has "Ghost OS and Robot Software[--] Comprehensive, low-level core control to higher application development environment and APIs, simulation, diagnostic tools, and applications." Exhibit F at 5, 6

109. The Vision 60 is capable of receiving a pose of a robotic device with respect to a ground surface. For example, the Vision 60 can assume a pose on the ground surface prior to traversing stairs:<sup>19</sup>



<sup>19</sup> Ghost Robotics, *Perception-Based Stair Climbing & Obstacle Management*, YOUTUBE (July 23, 2020), [https://www.youtube.com/watch?v=5sE\\_zssS4EQ](https://www.youtube.com/watch?v=5sE_zssS4EQ) at 0:00-0:40.

110. The Vision 60 is capable of receiving one or more contact points between the robotic device and the ground surface, each of the one or more contact points derived from sensor information generated by one or more sensors, each sensor of the one or more sensors associated with a respective leg of one or more legs of the robotic device. For example, Defendant’s product information identifies that the Vision 60 contains “Operational & Task Sensors,” including but not limited to a ToF sensor, that are used to “[m]inimize[] collision risk with environmental objects under autonomous or tele-operation including stairclimbing mode.” Exhibit F at 5, 6. On information and belief, the ToF sensor is an “Intel 435 depth sensor that lets it map the ground plane,” Exhibit K and is located in the following illustration of the Vision 60:<sup>20</sup>

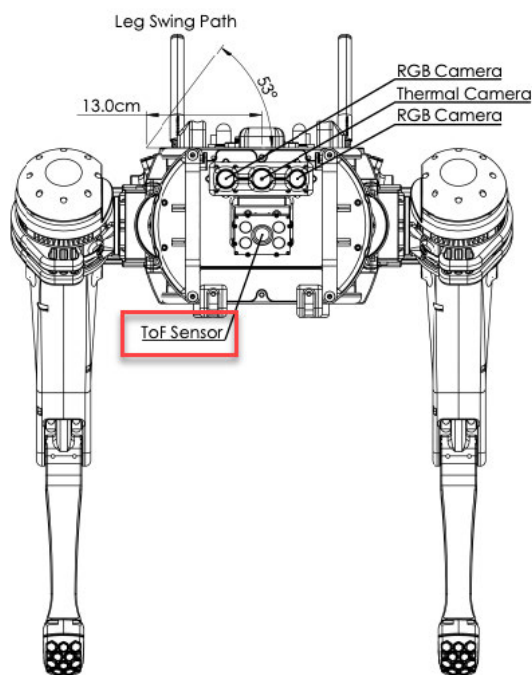

111. In addition, the Vision 60 “can, in a sense, literally feel the ground. Every time the feet strike the ground, all its motors will get a current spike, and we can measure that current spike

---

<sup>20</sup> Exhibit F at 7.

in combination with the onboard IMU to calculate how the robot has struck the ground, what its position is in terms of yaw and pitch, and how it's doing in balance.” Exhibit K.

112. The Vision 60 is capable of determining a ground plane estimation of the ground surface based on the pose of the robotic device with respect to the ground surface and the one or more contact points between the robotic device and the ground surface. For example, the Vision 60 detects the slope of the oncoming surface relative to the Vision 60's pose and location of its feet.<sup>21</sup>



---

<sup>21</sup> Ghost Robotics, *Perception-Based Stair Climbing & Obstacle Management*, YOUTUBE (July 23, 2020), [https://www.youtube.com/watch?v=5sE\\_zssS4EQ](https://www.youtube.com/watch?v=5sE_zssS4EQ) at 0:00-0:40.



The Vision 60 is capable of commanding the robotic device to adjust the pose with respect to the ground surface based on the ground plane estimation. For example, as the Vision 60 transitions from level surface to traversing up the stairs, the pitch of its body gradually increases until it matches the slope of the stairs:<sup>22</sup>

---

<sup>22</sup> Ghost Robotics, *Perception-Based Stair Climbing & Obstacle Management*, YOUTUBE (July 23, 2020), [https://www.youtube.com/watch?v=5sE\\_zssS4EQ](https://www.youtube.com/watch?v=5sE_zssS4EQ) at 0:00-0:40.



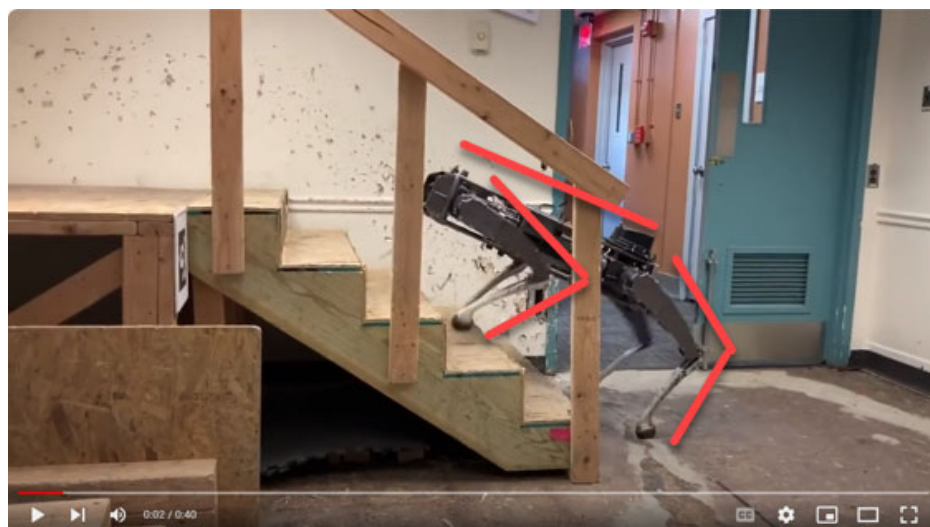

113. On information and belief, the Spirit 40 product has these same capabilities as the Vision 60, because the Spirit 40 and the Vision 60 share the same software. For example, Defendant's product information states that the Spirit 40 product is "**The Ultimate Research Robot**. Built on same software, SDK and electronics as the Vision and Wraith series Q-UGVs for enterprise and military." Exhibit G at 1. Thus, like the Vision 60, the Spirit 40 product similarly infringes at least claim 1 of the '819 patent.

114. Defendant has indirectly infringed and continues to indirectly infringe the claims of the '819 patent by inducing infringement pursuant to 35 U.S.C. § 271(b) and contributing to infringement pursuant to 35 U.S.C. § 271(c).

115. On information and belief, in violation of 35 U.S.C. § 271(b), Defendant specifically intended to induce infringement of the '819 patent by its customers and users of the Vision 60 and Spirit 40 products and had knowledge that the inducing acts would cause infringement or was willfully blind to the possibility that their inducing acts would cause infringement.

116. Defendant should have known of the '819 patent because Boston Dynamics cites the patent on its website and marks its Spot® robot with the number of that patent (*see* <https://www.bostondynamics.com/patents> (last visited Feb. 8, 2024)).

117. On information and belief, Defendant's customers directly infringe the '819 patent. For example, when the Vision 60 and Spirit 40 products are sold to customers, those customers infringe at least independent claim 9 of the '819 patent through their use of the Vision 60 and Spirit 40 products.

118. On information and belief, Defendant specifically intends that its customers infringe the '819 patent. Defendant encourages infringement by customers at least by providing

product support instructing users on how to use the Vision 60 and Spirit 40 products. For example, Defendant provides specification sheets. Exs. F; G. The specification sheets describe the features of the Vision 60 and Spirit 40 products, including “[t]ravers[ing] unstructured terrain,” climbing stairs, and “[s]afeguard [a]voidance.” Exhibit F at 5; Exhibit G at 3. As another example, Defendant provides support to its customers. Exhibit L at 1.

119. On information and belief, despite Defendant’s knowledge of the ’819 patent and knowledge that customers will necessarily infringe the ’819 patent when the Vision 60 and Spirit 40 products are used as instructed, Defendant continues to encourage infringement.

120. Defendant also contributes to infringement of the ’819 patent by Defendant’s customers in violation of 35 U.S.C. § 271(c). On information and belief, Defendant offers to sell and sells within the United States the Vision 60 and Spirit 40 products knowing that they are especially made or especially adapted for use in infringing the ’819 patent, and knowing that the Vision 60 and Spirit 40 products are not staple articles or commodities of commerce suitable for substantial non-infringing use.

121. Defendant has committed and continues to commit all of the above acts of infringement without license or authorization.

122. Boston Dynamics has complied with the requirements of 35 U.S.C. § 287 by, among other things, marking its products with the number of the ’819 patent. Defendant also knew or should have known of the ’819 patent because Boston Dynamics cites the patent on its website (*see* <https://www.bostondynamics.com/patents> (last visited Feb. 8, 2024)). Boston Dynamics will give actual notice of the ’819 patent to Defendant by service of this Complaint.

123. As a result of Defendant’s infringement of the ’819 patent, Plaintiff has suffered damages and will continue to suffer damages.

124. Under 35 U.S.C. § 283, Boston Dynamics is entitled to a permanent injunction against further infringement. Defendant's wrongful conduct has caused and will continue to cause Boston Dynamics to suffer irreparable harm resulting from the loss of its lawful patent right to exclude others from making, using, selling, offering for sale, and/or importing Boston Dynamics' patented inventions. On information and belief, Defendant will continue to infringe the '819 patent unless permanently enjoined by the Court.

**COUNT V— INFRINGEMENT OF THE '645 PATENT**

125. The allegations in the preceding paragraphs are incorporated by reference as if fully set forth herein.

126. Defendant has directly infringed, and continues to directly infringe, at least claim 1 of the '645 patent by using and testing in the United States the Vision 60 product, and has induced and contributed to the infringement of the '645 patent by others.

127. For example, and without limitation, on information and belief, the Vision 60 product meets every limitation of at least independent claim 1 of the '645 patent, and Defendant's making, using, offering for sale, selling, and/or importing into the United States the Vision 60 product directly infringes claim 1 of the '645 patent under 35 U.S.C. § 271(a).

128. Claim 1 of the '645 patent recites:

1. A drive system comprising:

a linear actuator comprising a drive shaft and having an actuation axis extending along a length of the linear actuator;

a motor assembly coupled to the drive shaft of the linear actuator and configured to rotate the drive shaft about the actuation axis of the linear actuator;

a nut attached to the drive shaft;

a carrier housing the nut;

a linkage system extending from a proximal end away from the motor assembly to a distal end, the proximal end rotatably attached to the carrier at a first proximal attachment location, the first proximal attachment location offset from the actuation axis; and

an output link rotatably coupled to a first distal attachment location on the distal end of the linkage system, the output link offset from the actuation axis, wherein a line bisecting the first proximal attachment location and the first distal attachment location converges toward the actuation axis in a direction extending from the first proximal attachment location to the first distal attachment location.

129. The Vision 60 is comprised of a drive system for the reasons discussed below.

130. The Vision 60 is comprised of a linear actuator with a drive shaft, a carrier housing a nut that is attached to the drive shaft, and an actuation axis extending along the actuator. For example, Defendant's product information states that the Vision 60 product "uses a standard drive-train with no exotic motors" and does not require "leg force sensors ... to move across unstructured environments." Ex. F at 2. It further states that the Vision 60 product uses "high-bandwidth actuators" in its legs. *Id.*

131. [REDACTED]

[REDACTED]

[REDACTED]

[REDACTED]

[REDACTED]

[REDACTED]

[REDACTED]

[REDACTED]

[REDACTED]

[REDACTED]

[REDACTED]

132. The Vision 60 product has a motor assembly that is coupled to the drive shaft of the linear actuator and rotates the drive shaft about the actuation axis. For example, Defendant’s product information states that “motors [are] located proximally [to the leg pod] to minimize inertia.” Ex. F at 6. A diagram in Defendant’s product information also shows that the motor assembly would cause the screw shaft to rotate, as shown below:

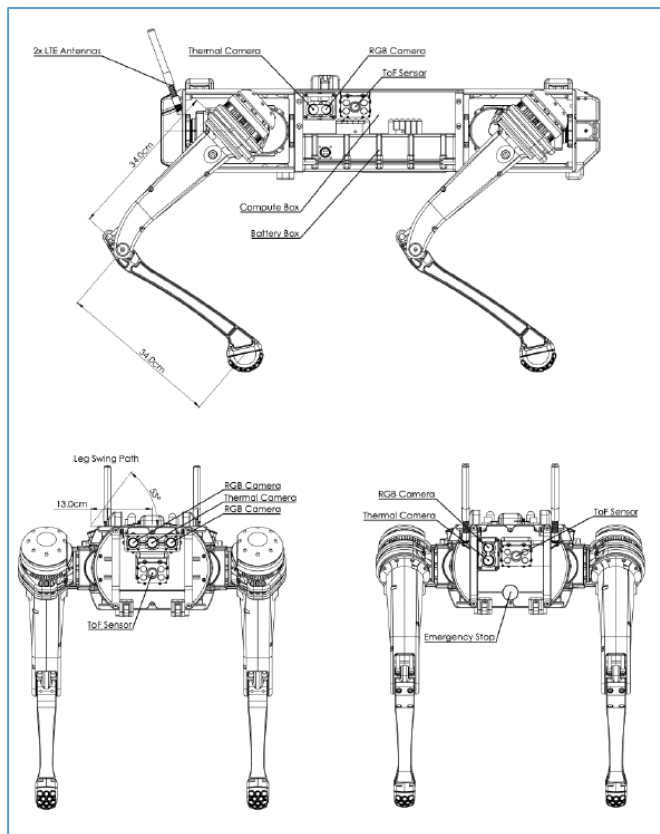

*Id.* at 7.

133. [REDACTED]

[REDACTED]

[REDACTED]

[REDACTED]

[REDACTED]

[REDACTED]

[REDACTED]



134. On information and belief, the Vision 60 product has a linkage system that extends from the proximal end away from the motor assembly to the distal end, where the proximal end is rotatably attached to the carrier at a location that is offset from the actuation axis. A diagram in Defendant's product information shows linkages extending from the proximal end of the upper leg member to the distal end:

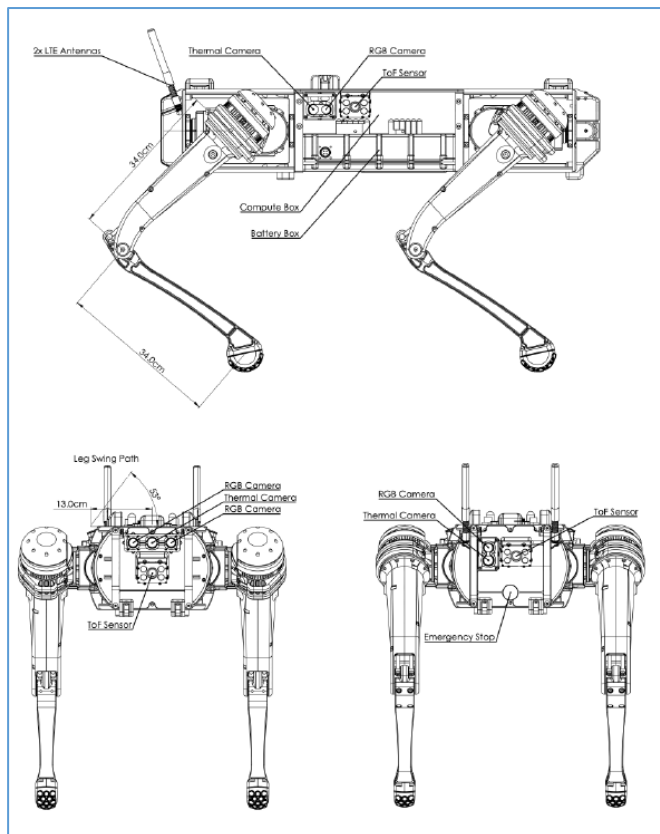

Ex. F at 7. The linkage system is rotatably attached to the carrier at a location that is offset from the actuation axis.

135. [REDACTED]

[REDACTED]

[REDACTED]

[REDACTED]

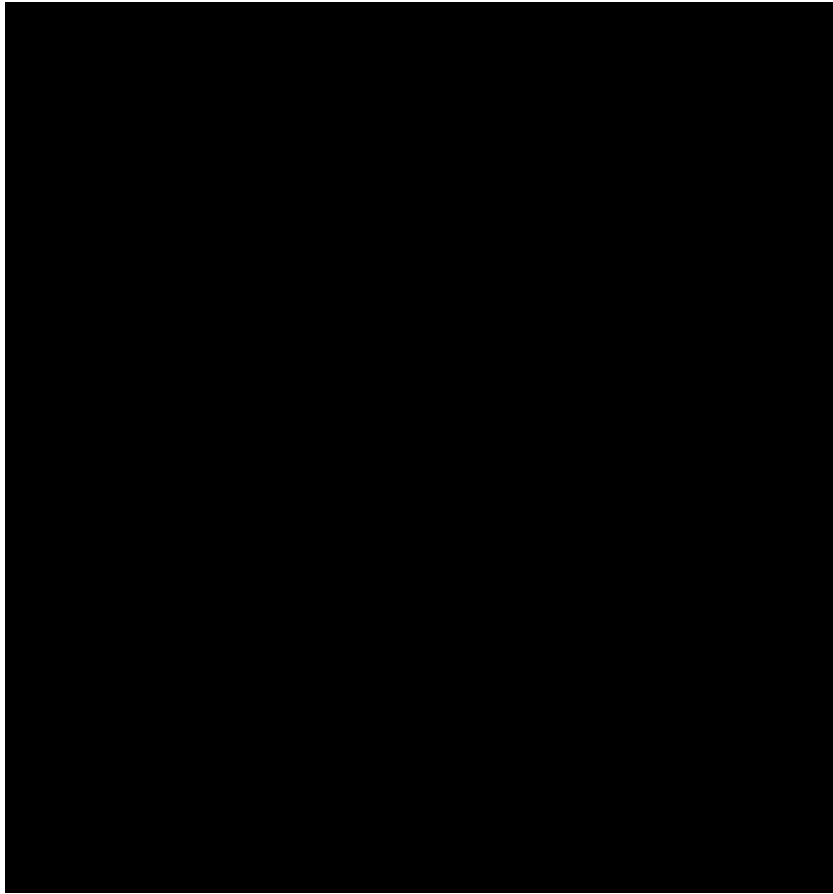

136. The Vision 60 product has an output link that is offset from the actuation axis and is rotatably coupled to the distal end of the linkage system at another location such that a line extending from the first location at the proximal end to the second location at the distal end of the linkage system converges toward the actuation axis. A diagram in Defendant's product information shows an output link that is offset from the actuation axis and rotatably coupled to the linkage system such that the connecting rods of the linkage system converge toward the actuation axis:

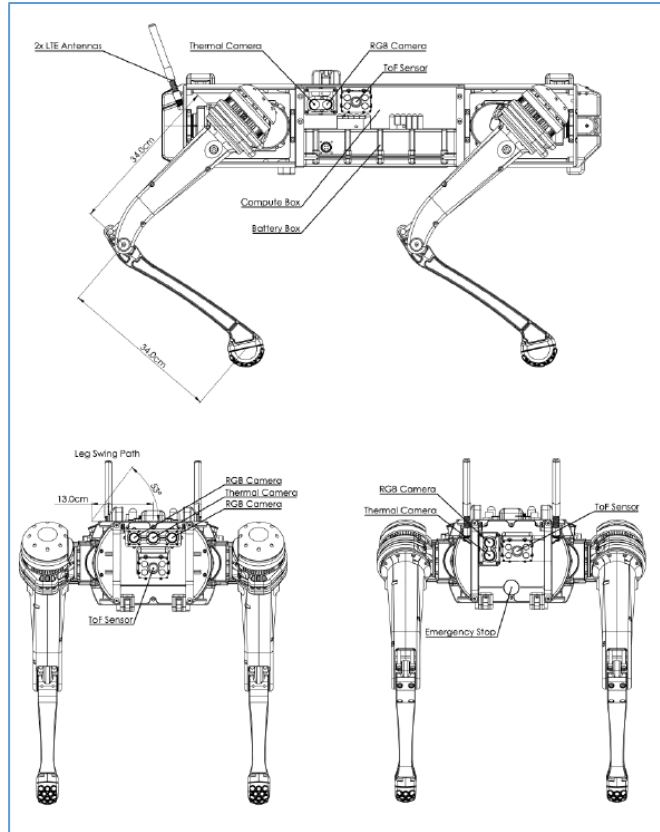

Ex. F at 7.

137.

[REDACTED]

[REDACTED]

[REDACTED]

[REDACTED]

[REDACTED]

[REDACTED]

[REDACTED]

[REDACTED]

[REDACTED]

[REDACTED]

[REDACTED]

[REDACTED]

138. On information and belief, Defendant's customers directly infringe the '645 patent. For example, when the Vision 60 product is sold to customers, those customers infringe at least independent claim 1 of the '645 patent through their use of the Vision 60 product.

139. Defendant has committed and continues to commit all of the above acts of infringement without license or authorization.

140. Boston Dynamics will give actual notice of the '645 patent to Defendant by service of this Complaint.

141. As a result of Defendant's infringement of the '645 patent, Plaintiff has suffered damages and will continue to suffer damages.

142. Under 35 U.S.C. § 283, Boston Dynamics is entitled to a permanent injunction against further infringement. Defendant's wrongful conduct has caused and will continue to cause Boston Dynamics to suffer irreparable harm resulting from the loss of its lawful patent right to exclude others from making, using, selling, offering for sale, and/or importing Boston Dynamics' patented inventions. On information and belief, Defendant will continue to infringe the '645 patent unless permanently enjoined by the Court.

#### **JURY DEMAND**

143. Pursuant to Federal Rule of Civil Procedure 38(b), Plaintiff demands a trial by jury of all issues so triable.

#### **PRAYER FOR RELIEF**

WHEREFORE, Plaintiff requests that judgment be entered in favor of Plaintiff and against Defendant as follows:

- a. A judgment that Defendant has infringed, and is currently directly and/or indirectly infringing, each of the Asserted Patents;
- b. An order awarding damages under 35 U.S.C. § 284 in an amount sufficient to compensate Plaintiff for its damages arising from infringement by Defendant,

including, but not limited to, lost profits and/or a reasonable royalty, together with pre-judgment and post-judgment interest, and costs;

- c. An order awarding treble damages for willful infringement by Defendant, pursuant to 35 U.S.C. § 284;
- d. That this Court preliminarily and permanently enjoin Defendant from infringing any of the Asserted Patents;
- e. An accounting and/or supplemental damages for all damages occurring after any discovery cutoff and through the Court's decision regarding the imposition of a permanent injunction;
- f. A judgment declaring that this case is exceptional and awarding Plaintiff its reasonable costs and attorneys' fees pursuant to 35 U.S.C. § 285; and
- g. Such other relief as this Court or a jury may deem just and proper under the circumstances.

MORRIS, NICHOLS, ARSHT & TUNNELL LLP

*/s/ Cameron P. Clark*

OF COUNSEL:

Steven C. Cherny  
QUINN EMANUEL URQUHART  
& SULLIVAN, LLP  
51 Madison Avenue, 22nd Floor  
New York, NY 10010  
(212) 849-7000

Deepa Acharya  
QUINN EMANUEL URQUHART  
& SULLIVAN, LLP  
1300 I Street, NW, Suite 900  
Washington, DC 20005  
(202) 538-8000

July 25, 2024

---

Jack B. Blumenfeld (#1014)  
Brian P. Egan (#6227)  
Cameron P. Clark (#6647)  
1201 North Market Street  
P.O. Box 1347  
Wilmington, DE 19899  
(302) 658-9200  
jblumenfeld@morrисnichols.com  
began@morrисnichols.com  
cclark@morrисnichols.com

*Attorneys for Plaintiff*