

**IN THE UNITED STATES DISTRICT COURT  
FOR THE EASTERN DISTRICT OF TEXAS  
SHERMAN DIVISION**

**ENCRYPTAWAVE TECHNOLOGIES  
LLC,**

Plaintiff,

v.

**VANTIVA SA,**

Defendant.

C.A. No. 4:24-cv-846

**JURY TRIAL DEMANDED**

**PATENT CASE**

**ORIGINAL COMPLAINT FOR PATENT INFRINGEMENT**

Plaintiff Encryptawave Technologies LLC files this Original Complaint for Patent Infringement against Vantiva SA, and would respectfully show the Court as follows:

**I. THE PARTIES**

1. Plaintiff Encryptawave Technologies LLC (“Encryptawave” or “Plaintiff”) is an Illinois limited liability company with its address at 23832 Rockfield Boulevard, Suite 170, Lake Forest, CA 92630.

2. On information and belief, Defendant Vantiva SA (“Defendant” or “Vantiva”) is a company organized and existing under the laws of France, having its place of business at 10, boulevard de Grenelle, 75015 Paris, France.

**II. JURISDICTION AND VENUE**

1. This action arises under the patent laws of the United States, Title 35 of the United States Code. This Court has subject matter jurisdiction of such action under 28 U.S.C. §§ 1331 and 1338(a).

2. On information and belief, Defendant is subject to this Court's specific and general personal jurisdiction, pursuant to due process and the Texas Long-Arm Statute, due at least to its business in this forum, including at least a portion of the infringements alleged herein.

3. Without limitation, on information and belief, within this state, Defendant has used the patented inventions thereby committing, and continuing to commit, acts of patent infringement alleged herein. In addition, on information and belief, Defendant has derived revenues from its infringing acts occurring within Texas. Further, on information and belief, Defendant is subject to the Court's general jurisdiction, including from regularly doing or soliciting business, engaging in other persistent courses of conduct, and deriving substantial revenue from goods and services provided to persons or entities in Texas. Further, on information and belief, Defendant is subject to the Court's personal jurisdiction at least due to its sale of Instrumentalities and/or services within Texas. Defendant has committed such purposeful acts and/or transactions in Texas such that it reasonably should know and expect that it could be haled into this Court as a consequence of such activity.

4. Venue is proper in this district under 28 U.S.C. § 1400(b). On information and belief, from and within this District Defendant has committed at least a portion of the infringements at issue in this case.

5. For these reasons, personal jurisdiction exists and venue is proper in this Court under 28 U.S.C. § 1400(b).

**III. COUNT I**  
**(PATENT INFRINGEMENT OF UNITED STATES PATENT NO. 7,233,664)**

6. Plaintiff incorporates the above paragraphs herein by reference.

7. On June 19, 2007, United States Patent No. 7,233,664 ("the '664 Patent") was duly and legally issued by the United States Patent and Trademark Office. The '664 Patent is titled

“Dynamic Security Authentication for Wireless Communication Networks.” A true and correct copy of the ‘664 Patent is attached hereto as Exhibit C and incorporated herein by reference.

8. Encryptawave is the assignee of all right, title and interest in the ‘664 patent, including all rights to enforce and prosecute actions for infringement and to collect damages for all relevant times against infringers of the ‘664 Patent. Accordingly, Encryptawave possesses the exclusive right and standing to prosecute the present action for infringement of the ‘664 Patent by Defendant.

9. The invention in the ‘664 Patent relates to the field of wireless communication network security, more particularly to a dynamic authentication method and system for providing secure authentication among wireless communication network nodes. (*Id.* at col. 1:18-22).

10. The objective of cryptography is to allow users to communicate securely through an insecure shared data communications channel while maintaining data integrity, privacy, and user authentication. (*Id.* at col. 1:24-27). Over the past century, cryptographic systems have been developed that require a great deal of time to break, even when using large computational power. (*Id.* at col. 1:27-30). However, once an encryption key is obtained, the encryption mechanism and likely the entire system security is compromised and a new key is required. (*Id.* at col. 1:30-33). The two most common strategies for make an encryption system difficult to penetrate are: (1) a long encryption key, and/or (2) a complex encryption function. (*Id.* at col. 1:34-37). For example, for an encryption key of length  $n$  bits, for large values of  $n$  a code breaker would need more than a lifetime to break the cipher. (*Id.* at col. 1:37-39). Simpler encryption functions, such as the logic XOR function, is easy to decipher no matter how long the key length is. (*Id.* at col. 1:39-43). For examples, a logic XOR operation is performed on one bit of data and its corresponding bit from the encryption key, one bit at a time: if the bits are the same then the result is 0 and if the bits are

different then the result is 1. (*Id.* at col. 1:43-45). The simple linearity of the XOR function allows an intruder to decipher individual key fragments using a divide-and-conquer approach and then reconstruct the entire key once all the individual fragments are obtained. (*Id.* at col. 1:47-51). A non-linear exponential encryption function, such as Rivest-Sharmi-Adelman (RSA) system, is more difficult to apply a divide-and-conquer approach to break the key. (*Id.* at col. 1:51-54).

11. At the time the patent application was filed, there were two major cryptography system philosophies: 1) symmetric systems (static or semi-dynamic key), and 2) public key systems (static key). (*Id.* at col. 1:55-57). In symmetric systems, a key is exchanged between the users (the sender and receiver) and is used to encrypt and decrypt the data. (*Id.* at col. 1:57-60). There are three main problems with the symmetric system. (*Id.* at col. 1:60-61). First, the exchange of the key between the users introduces a security loophole, which can be alleviated through encrypting the exchanged key using a secure public key cryptography system. (*Id.* at col. 1:61-64). Second, using only one static encryption key makes it easier for an intruder to have sufficient time to break the key, which can be addressed using multiple session keys that are exchanged periodically. (*Id.* at col. 1:64-66). Third, and most important, is the susceptibility to an insider attack on the key where the time window between exchanging keys might be long enough for a super user, who has super user privileges, to break in and steal the key. (*Id.* at col. 2:1-6).

12. In RSA public key cryptography system, a user generates two related keys, reveals one to the public (“public” key) to be used to encrypt any data sent and a second key that is private to the user (“private” key) that is used to decrypt received data by the user. (*Id.* at col. col. 2:7-11). The RSA cryptography system generates large random primes and multiplies them to get the public key and uses a complex encryption function such as mod and exponential operations, which

makes the technique unbreakable in a lifetime for large keys (*e.g.*, higher than 256 bits) and eliminates the problem of insecure exchange of symmetric keys. (*Id.* at col. 2:15-20). However, the huge computational time required by RSA encryption and decryption, in addition to the time to generate the keys, is not appealing to users of the Internet and is therefore mainly used as one-shot solid protection of the symmetric cryptography key exchange. (*Id.* at col. 2:20-25). This one-shot protection, however, allows an internal super user with a helper to generate its own pair of encryption keys and replace the original keys. (*Id.* at col. 2:24-25). The sender then uses the super user's public key so the super user can decrypt the cipher text, store it, re-encrypt it using the original public key to continue the data to the original recipient for decrypting using the original private key without any knowledge of the break that occurred in the middle (a "super-user-in-the-middle" attack). (*Id.* at col. 2:29-40).

13. Even though both symmetric and public key cryptography systems are secure against outside attack, they are still vulnerable to insider attacks. (*Id.* at col. 2:41-48). A common way to protect a static encryption key is to save it under a file with restricted access but this cannot prevent a person with super user privileges from accessing the static key of the host file. (*Id.* at col. 2:50-53). Various attempts have been made to circumvent intrusion by outside users, however, they are still prone to attack by super-user-in-the-middle attacks. (*Id.* at col. 2:53 – col. 3:3). The invention in the '664 patent alleviates these problems by providing continuous encryption key modification. (*Id.* at col. 4:26-29).

14. There was a need for security for wireless communications in networks, including allowing mobile communication devices to move between access ports or base stations while maintaining full, mutually secure authentication. (*Id.* at col. 3:4-12). In wireless local area networks, the Wired Equivalent Privacy (WEP) algorithm is used to protect wireless

communication from eavesdropping. (*Id.* at col. 3:33-36). WEP relies on a secret encryption key that is shared between a supplicant, such as a wireless laptop personal computer, and an access point. (*Id.* at col. 3:36-39). The secret key is used to encrypt data packets before they are transmitted, and an integrity check is used to ensure that packets are not modified in transit. (*Id.* at col. 3:39-41). The standard does not discuss how the shared key is established; however, in practice, most installations use a single key that is shared between all mobile stations and access points. (*Id.* at col. 3:41-44).

15. Ineffective WEP security lead to different types of attacks by outsiders. (*Id.* at col. 3:60-61). For example, a passive eavesdropper can intercept all wireless traffic and through known methodologies and educated guesses can narrow the field of the contents of a message and possibly determine the exact contents to of the message. (*Id.* at col. 3:45 – col. 4:6). Another type of attack when using a WEP algorithm is if an attacker knows the exact plaintext for one encrypted message, the attacker can use this knowledge to construct correct encrypted packet. (*Id.* at col. 4:7-17). Therefore, despite the WEP algorithm being part of the standard that describes communications in wireless local area networks, it fails to protect the wireless communications from eavesdropping and unauthorized access to wireless networks, primarily because it relies on a static secret key shared between the supplicant and the wireless network. (*Id.* at col. 4:18-24).

16. There are several benefits to the claimed invention. The key lifetime is too small for an intruder to break and a super-user to copy. (*Id.* at col. 4:29-31). The invention also reduces the computations overhead by breaking the complexity of the encryption function and shifting it over the dynamics of data exchange. (*Id.* at col. 4:32-35). Speed is also improved by using a simple logic encryption function. (*Id.* at col. 4:35-36). Encryption is fully automated and all

parties, the source user, destination user, and central authority, are clock-free synchronized and securely authenticated at all times. (*Id.* at col. 4:44-47).

17. The prosecution history of the '664 patent further explains the unconventional features of the claimed invention. The examiner allowed the relevant claims without rejection because the prior art of record did not teach installing a node identifier at a first network node; sending the node identifier information from a first network node to a second network node, and synchronously regenerating an authentication key at two network nodes based upon node identifier information. (Ex. B at 2).

18. **Direct Infringement.** Upon information and belief, Defendant has been directly infringing claim 1 of the '664 patent in Texas, and elsewhere in the United States, by performing actions comprising using or performing the claimed method of providing secure authentication between wireless communication network nodes by using and/or testing the Technicolor/Thomson C2000T, Technicolor/Thomson TG233, Technicolor/Thomson TD5136, Technicolor/Thomson TD5130, Technicolor/Thomson TG784n-v3, Technicolor/Thomson CGA4131, Technicolor/Thomson CGM4981, CGA4233CLP2, DGA4122, GA2131, DWA0122BLN, DGA0122LTT, DGA0122NLK, CGA4233TCH5, CGA4233TCH4, DGA2231TMX, THG3000, CGA4233DE, DGA2232PTN, DGA4231, TG789vac v3, DWA0120, FGA2130FWB, DGA2231, CGA4233STO, Vodafone H500-p Gateway, CGA4233-EU, DJA0230TLS, DJN2231TLS, TG1700dac, CGA4131TCH, DGA4132TIM, CWA0121, DGA4331TIM, OWA0130, DJA0231TLS, DGA4131FWB, FGA2233MAG, OWA0131TCH, DGA4331TIM, FGA2232, DGA0122TCS, DJA0230TLS, FGA5330TCH, FGA2230, DJA0231TLS, DGA4330, DGA0120, DJA0231TLS, FGA2110, THG3000g, CGA4233VDF, OWA0130, DGA4131FWB, CGA4131COM, CGA2121, CGA0101, Vodafone H 500-t, MWA1100, DWA0100, and

DPC3928SL2 (“Accused Instrumentalities”). The Technicolor CGA4131 as shown below is exemplary of the infringement.

19. For example, a system utilized by the Accused Instrumentalities practices a method of providing secure authentication between wireless communication (*e.g.*, Wi-Fi) network nodes (*e.g.*, the Accused Instrumentalities and accessory devices such as a Wi-Fi enabled smartphone, etc.). As shown below, the Accused Instrumentalities provides wireless connection to accessory devices and allows them to join its Wi-Fi network. The Accused Instrumentalities sets a password to secure the Wi-Fi network. The Accused Instrumentalities utilizes WPA2 security, which is based on the IEEE 802.11i standard, to set a password.

<h3>Modem Information</h3>	<h3>Highest Service Level</h3>
<ul style="list-style-type: none"><li>✓ DOCSIS 3.1 Dual Band 802.11-AC</li><li>✓ 32x8 channel bonding</li><li>✓ Compatible with future speed increases</li></ul>	<p>Cox Business Gigabit</p>
<h3>Front View</h3>	<p>After the cable modem is successfully registered on the network, a single solid white LED illuminates continuously to indicate that the cable modem is online and fully operational.</p>
	<p><b>Important:</b> After connecting the modem for the first time, wait 10-15 minutes before attempting to complete the WiFi setup or get online. Do not unplug the modem from power or factory reboot the modem during the initial 10-15 minute firmware download and modem registration process.</p>
<p><a href="#">Click to enlarge.</a></p>	

(*E.g.*, <https://www.cox.com/business/support/technicolor-cga4131.html>).



**Figure 22: Wireless Security Settings**

The screenshot displays the 'Technicolor Wireless Cable Voice Gateway' web interface. The 'Wireless' tab is selected, and the 'Security' sub-tab is active. The settings for the '2.4GHz Wireless Network' are as follows:

Setting	Value
Network Name	1101AC-2.4
Security Mode	WPA or WPA2 Personal
Encryption	AES/TKIP
Network Password	***** (with a 'Show' toggle)
Key Interval	3600 Seconds

Available settings include:

**Network Name:** The Network Name is displayed here.

**Security Mode:** Options for security settings include:

- **2.4GHz:** Open, WPA2 Personal, WPA or WPA2 Personal
- **5GHz:** Open, WPA2 Personal, WPA or WPA2 Personal

The default setting is WPA or WPA2 Personal.

(E.g., <https://www.cox.com/content/dam/cox/business/documents/internet/CBIG%204131%20User%20Guide.pdf>).

**Figure 23: WPS Settings**

technicolor Wireless (WPS) Technicolor Wireless Cable Voice Gateway

Status Connection **Wireless** Security Application Administration Diagnostic

Radio Security Advanced Guest Network MAC Control **WPS** CoS Hotspot

Wi-Fi Protected Setup (WPS)

AccessPoint PIN 31752893

Connection Method Push Button (recommended) ▼

Pair with my Wi-Fi client

**2.4GHz Wireless Network**

Network Name 1101AC-2.4

Security Mode WPA-WPA2-Personal

**5GHz Wireless Network**

Network Name 1101AC-5

Security Mode WPA-WPA2-Personal

## ***Prevent Devices from Accessing Your Wireless Network***

### **MAC Address**

A MAC (Media Access Control) address is a unique hexadecimal code that identifies a device on a network. Each network-enabled device has at least one unique MAC address.

For example, if your computer is equipped with an Ethernet and a wireless network adaptor, each of these interfaces will have its own MAC address.

(E.g., <https://www.cox.com/content/dam/cox/business/documents/internet/CBIG%204131%20User%20Guide.pdf>).



## Technicolor / Thomson C2000T

details: Wireless n VoIP Broadband Gateway with HPNA  
 hardware type: DSL Wireless Router  
 date added: 2017-08-01



Technicolor C2000T Wireless 802.11N ADSL2+ VDSL Modem Router Combo.

The C2000T features a built-in HPNA 3.1 compliant adapter that allows distribution of high-quality data and video inside the home over existing coax wires. Hence, it is ideal for IPTV deployments with minimal impact on subscribers' homes: Set-top boxes can be directly connected to the gateway over the present network infrastructure. Furthermore, the HPNA adapter enables HD streaming speeds of up to 190 Mbps and an advanced QoS.



The Technicolor firewall guarantees users the ultimate level in network security. Through integration with NAT, the firewall leverages all the Application Level Gateways (ALGs) provided in the NAT context to minimize undesired service impact. The firewall provides Stateful Packet Inspection (SPI), and an integrated Intrusion Detection and Prevention System (IDS) engine monitors a wide range of attack patterns, and logs potential security breaches to a local cache or remote server. The C2000T also supports powerful wireless security mechanisms, such as Wi-Fi Protected Access (WPA2).

(E.g., <https://www.speedguide.net/routers/technicolor-thomson-c2000t-wireless-n-voip-broadband-3985>).



## Technicolor / Thomson TG233

details: Wireless Access Point  
 hardware type: Wireless Access Point  
 date added: 2013-07-06  
 updated: 2017-02-05

Wireless	
Maximum Wireless Speed:	600 Mbps (Wi-Fi 4)
WiFi standards supported:	802.11b (Wi-Fi 1) 802.11g (Wi-Fi 3) 802.11n (Wi-Fi 4)
Wifi security/authentication:	WEP WPA (TKIP) WPA2 (AES)
WiFi modes:	Access point
Multiple SSID:	✓
WMM (QoS):	✓
WPS (Wi-Fi Protected Setup):	✓
Beamforming:	✓

(E.g., <https://www.speedguide.net/routers/technicolor-thomson-tg233-wireless-access-point-3081>).



## Technicolor / Thomson TD5136

details: Wireless-N ADSL2+ Gateway  
hardware type: DSL Wireless Router  
date added: 2013-06-30  
updated: 2015-06-25

### Wireless

Maximum Wireless Speed:	300 Mbps (Wi-Fi 4)
WiFi standards supported:	802.11b (Wi-Fi 1) 802.11g (Wi-Fi 3) 802.11n (Wi-Fi 4)
Wifi security/authentication:	WEP WPA (TKIP) WPA2 (AES)
WiFi modes:	Access point
Multiple SSID:	✓
WMM (QoS):	✓
WPS (Wi-Fi Protected Setup):	✓

(E.g., <https://www.speedguide.net/routers/technicolor-thomson-td5136-wireless-n-adsl2-gateway-3079>).



# Technicolor / Thomson TD5130

details: Wireless ADSL2+ Gateway  
hardware type: DSL Wireless Router  
date added: 2013-06-30  
updated: 2015-06-25

Wireless	
Maximum Wireless Speed:	150 Mbps (Wi-Fi 4)
WiFi standards supported:	802.11b (Wi-Fi 1) 802.11g (Wi-Fi 3) 802.11n (Wi-Fi 4)
Wifi security/authentication:	WEP WPA (TKIP) WPA2 (AES)
WiFi modes:	Access point
Multiple SSID:	✓
WMM (QoS):	✓
WPS (Wi-Fi Protected Setup):	✓

(E.g., <https://www.speedguide.net/routers/technicolor-thomson-td5130-wireless-adsl2-gateway-3078>).



# Technicolor / Thomson TG784n v3

details: Wireless-N ADSL2+ VoIP Gateway

hardware type: VoIP Gateway

date added: 2013-06-30

updated: 2015-06-26

## Wireless

Maximum Wireless Speed:	300 Mbps (Wi-Fi 4)
WiFi standards supported:	802.11b (Wi-Fi 1) 802.11g (Wi-Fi 3) 802.11n (Wi-Fi 4)
Wifi security/authentication:	WEP WPA (TKIP) WPA2 (AES)
WiFi modes:	Access point
Multiple SSID:	✓
WMM (QoS):	✓
WPS (Wi-Fi Protected Setup):	✓

(E.g., <https://www.speedguide.net/routers/technicolor-thomson-tg784n-v3-wireless-n-adsl2-3077>).

### Back View



[Click to enlarge.](#)

The Technicolor CGM4981 has the following ports and buttons.

- WPS - Located on the back of the gateway above the telephone ports, this button can be used instead of entering the WiFi password to connect wireless devices that support WPS to the gateway. WPS works only for wireless networks that use passwords encrypted with the WPA Personal or WPA2 security protocols.
  - ⚠ Pressing and holding the WPS button for 60 seconds results in a factory reset. All customized settings are lost, and all settings are set back to factory defaults.
- Telephone Ports - Connect to home telephone wiring and conventional telephones or fax machines: The telephone port on the top left side is for the first line of phone service. The top right telephone port has a plug labeled **do not remove** and can only be removed when there is a second line of phone service.
- Ethernet Ports - Ethernet ports 1, 2, 3, and 4 can connect to the 10/100/1000 Ethernet ports on your computers or other devices. It is recommended that devices be hardwired if possible. Ethernet port 4 on the bottom right is the only 2.5 Gbps ethernet port. The other three ethernet ports are 1 Gbps ethernet ports.

(E.g., <https://publish-p47652-e412724.adobeacmcloud.com/residential/support/technicolor-cgm4981.html>).

## Back View



[Click to enlarge.](#)

The Technicolor CGM4141 has the following ports and buttons.

- TEL 1 / TEL 2 – Connects to home telephone wiring and to conventional telephones or fax machines. TEL 1 is used for the first line of phone service and TEL 2 is for a second line of service.
- ETH 1 / ETH 2 – Two ports are available to connect to the 10/100/1000 Ethernet ports on your computer or other device. It is recommended that devices be hardwired if possible.
- RESET – This is recessed to prevent accidental resets and is used to restore all settings to factory defaults. Factory resets result in the loss of all settings. To restore factory defaults, press and hold the indented Reset button for more than 10 seconds or until the front panel LED flashes.
- MoCA LIGHT – When the solid white light above the coaxial input is on, MoCA is enabled and allows for connections to specific cable receivers.
- CABLE COAXIAL INPUT – Connects the coax cable to the cable wall outlet.
- POWER – Connects the power cord to the modem.
- WPS – Located on the top of the modem, this button can be used instead of entering the WiFi password to connect wireless devices that support WPS to the Technicolor CGM4141. WPS works only for wireless networks that use a password that is encrypted with the WPA Personal or **WPA2** Personal security protocols.

(E.g., <https://manuals.plus/cox/technicolor-cgm4141>).

Product Info	
Date of Certification	December 17, 2020
Company	Vantiva
Product Name	CGA4233CLP2
Product Model Variant	CGA4233CLP2
Model Number	CGA4233CLP2
Category	Routers
Sub-category	Cable, DSL or Other Broadband Gateway (Integrated Home Access Device)

Summary of Certifications	
CLASSIFICATION	CERTIFICATION
Access	Wi-Fi Protected Setup™
Connectivity	2.4 GHz Spectrum Capabilities 5 GHz Spectrum Capabilities Wi-Fi CERTIFIED™ a Wi-Fi CERTIFIED™ ac Wi-Fi CERTIFIED™ b Wi-Fi CERTIFIED™ g Wi-Fi CERTIFIED™ n
Optimization	WMM® WMM®-Power Save
Security	Protected Management Frames WPA2™-Enterprise WPA2™-Personal 2017-10

(E.g., <https://api.cert.wi-fi.org/api/certificate/download/public?variantId=98297>).



The DGA0122 also supports powerful wireless security mechanisms such as Wi-Fi Protected Access (WPA, WPA2) together with the secure and user friendly Wi-Fi Protected Setup (WPS) connection and configuration mechanism for connecting wireless clients.

In addition, the DGA0122 supports multiple wireless network (mSSID) enabling to set up independent virtual wireless access points, including controlled wireless hotspots. These additional wireless networks allow other wireless users to enjoy high performance access without any compromise on the integrity of the basic network, thus keeping the original network access limited and secure.

(E.g., <https://www.netxl.com/technicolor/docs/technicolor-dga0122-datasheet.pdf>).

## TECHNICOLOR CGA2121

### DOCSIS 3.0 WIRELESS GIGABIT-CLASS CABLE GATEWAY WITH VOICE

The CGA2121 is a EuroDOCSIS/DOCSIS 3.0 cable gateway introducing the next generation in ultrahigh-speed data services. This new cable solution offers next to 8 bonded upstream channels, 24 bonded downstream channels for wired gigabit download speeds of up to 1.2 Gbps. Operators can now offer their customers even faster broadband access as well as demanding IPTV services.



WIFI	
Full dual band concurrent WiFi access points, WiFi certified®	<ul style="list-style-type: none"> <li>• 2.4 GHz (2x2) IEEE 802.11n AP</li> <li>• 5 GHz (3x3) IEEE 802.11ac AP with IEEE 802.11ac compliant transmit beamforming</li> </ul>
WiFi Protected Setup (WPS™)	
WiFi security levels	<ul style="list-style-type: none"> <li>• WPA2™-Enterprise / WPA™-Enterprise</li> <li>• WPA2™-Personal / WPA™-Personal</li> <li>• IEEE 802.1x port-based authentication with RADIUS client</li> </ul>

(E.g., [https://www.normann-engineering.com/products/product\\_pdf/cable\\_modems/technicolor/EN\\_CGA2121.pdf](https://www.normann-engineering.com/products/product_pdf/cable_modems/technicolor/EN_CGA2121.pdf)).

## 3.2.1 Configuring WPA(2) PSK encryption

### Procedure

Proceed as follows:

- 1 Browse to the DWA0120 web interface.  
For more information, see “4.1.1 Accessing the DWA0120 web interface from your local network” on page 36.
- 2 Click **Wireless**. The **Wireless** page appears.
- 3 On the left menu, select the Wi-Fi access point that you want to configure.
- 4 In the **Security Mode** list under **Access Point**, select one of the following modes:
  - **WPA2 PSK**  
This mode provides the highest security. Choose this version if you are sure that all your Wi-Fi clients support WPA2 PSK.
  - **WPA+WPA 2 PSK**  
Choose this option if not all of your Wi-Fi clients support WPA2 PSK, or if you are not sure. Wi-Fi clients that support WPA2 PSK will use WPA2 PSK, the others will use WPA PSK.
- 5 In the **Wireless Password** box, type a the key of your choice. The key must consist of 8 to 63 alphanumeric characters.
- 6 Click **Save**.
- 7 Reconnect your Wi-Fi client(s) to your DWA0120 using the new security settings.  
For more information, see “3.1.1 Connecting to the Wi-Fi using WPS” on page 22 or “3.1.3 How to manually connect a Wi-Fi client” on page 26.

(E.g., <https://www.manualslib.com/manual/2156969/Technicolor-Dwa0120.html?page=32#manual>).

technicolor  
FEEL THE WONDER

**CGA4233**  
Wireless .11ac  
Smart Ultra-Broadband Cable Gateway with Voice  
for above Gigabit Speeds

32 x 8  
D3.1

CABLE DATA VOICE VIDEO

The CGA4233 is a DOCSIS® 3.1 capable cable gateway offering triple-play services beyond Gigabit speeds, while providing VoIP functions for residential and business markets. Thanks to its integrated wireless video bridge featuring a robust chipset and 4x4 antennas, the CGA4233 can support seamless real-time HD video streaming over next generation IEEE 802.11ac Wi-Fi without any interruption of your data traffic.

## ■ Advanced Security

The integrated firewall provides Stateful Packet Inspection (SPI), and an integrated Intrusion Detection and Prevention System (IDS) engine which monitors a wide range of attack patterns, and logs potential security breaches to a local cache or remote server.

To secure data exchange between the gateway and the cable operators' servers, BPI+ communications privacy is used.

The CGA4233 also supports powerful wireless security mechanisms, such as Wi-Fi Protected Access (WPA, **WPA2**), together with a secure and user friendly connection and configuration mechanism for connecting wireless clients (WPS).

(E.g., [https://www.normann-engineering.com/products/product\\_pdf/ccap\\_cmts\\_-\\_cable\\_modems/technicolor/DS\\_Technicolor\\_CGA4233\\_EXT\\_v01.pdf](https://www.normann-engineering.com/products/product_pdf/ccap_cmts_-_cable_modems/technicolor/DS_Technicolor_CGA4233_EXT_v01.pdf)).

Home > Technicolor > Technicolor DGA2231 Ultra-Broadband Gateway with Voice



The image shows a black Technicolor DGA2231 Ultra-Broadband Gateway with Voice. The device is a rectangular, vertically-oriented unit with a dark front panel. At the bottom of the front panel, there are several indicator lights and labels: 'MODEM', 'ETHERNET', 'PHONE', and 'Wi-Fi'. The device is centered within a white-bordered frame that includes navigation arrows on the left and right sides and a 'Click to zoom' button below it.

### Technicolor DGA2231 Ultra-Broadband Gateway with Voice

Part Number: DGA2231

**Discontinued**  
This product has been discontinued. [See similar products.](#)

 Easy Returns

The Technicolor DGA2231 is a Smart Ultra-Broadband Gateway, compatible with dual-band 11n and 11ac Wi-Fi. The DGA2231 is fully integrated ADSL/ADSL2+/VDSL2 modem and G.Fast modem. It is suitable for larger areas with more demanding workloads, and supports VoIP functions for residential and business users.



The DGA2231 Stateful Pack Inspection (SPI) firewall guarantees the ultimate network security level. Advanced smart parental controls, security audit services, access logging and monitoring are optionally available for you to create a fully personalised, time-based access control environment. The router also supports powerful wireless security mechanisms, such as Wi-Fi Protected Access (WPA, **WPA2**) together with the secure and user friendly Wi-Fi Protected Setup (WPS) connection and configuration mechanism for connecting wireless clients.

(E.g., <https://www.netxl.com/dsl-modems/technicolor-dga2231-ultra-broadband-gateway-with-voice/>).

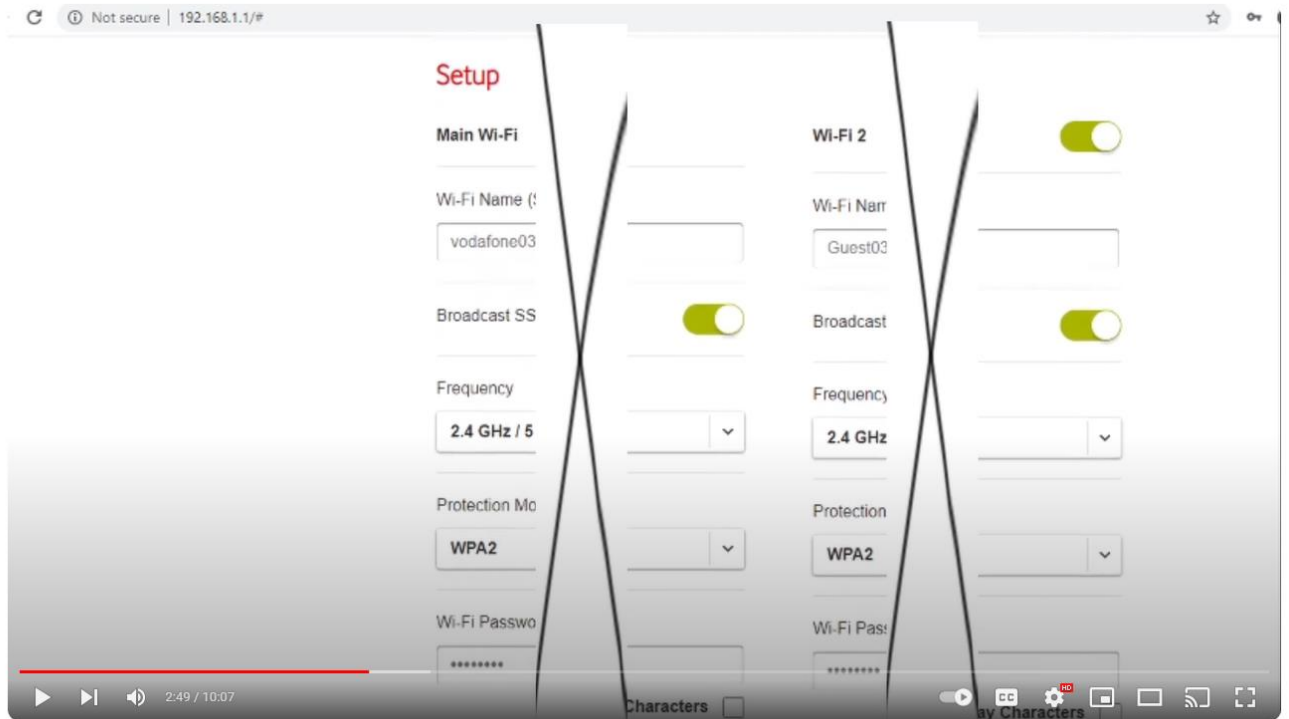

Vodafone Wi-Fi Hub THG3000 Router and web interface.

(E.g., <https://www.youtube.com/watch?v=7oYeJmJs9SM>).

## Wireless

show advanced

Interface Config Client Info Time Control

ACCESS POINTS 2.4GHZ

TNCAPF6D2CF

ACCESS POINTS 5GHZ

TNCAPF6D2CF-5G

WIRELESS DATA

Analyzer 2.4GHz

Analyzer 5GHz

### Interface

Enabled

Frequency band 2.4GHz

MAC address A4:91:B1:F6:D2:CF

Speed 130Mbps

Channel Auto

Current channel 11

### Access Point

Enabled

SSID name TNCAPF6D2CF

Security Mode WPA2 PSK

Wireless Password q9gCk4cT63cr4zxN

WPS

WPS AP PIN code 52599910

WPS Device PIN code

Set PIN code

WPS PBC Trigger

(E.g., <https://www.kcom.com/home/help/broadband/how-do-i-change-the-wireless-name-and-password-on-my-technicolor-dga4231-dga2231-or-dwa0120-router/>).

# USER MANUAL

## TG-789 Broadband Gateway

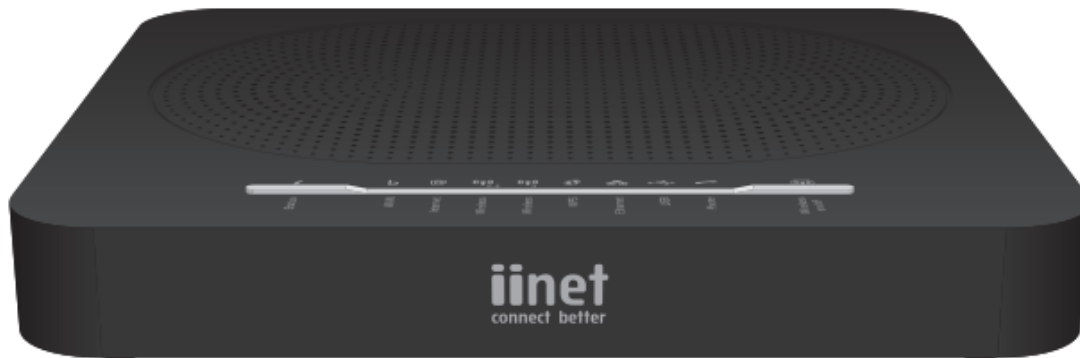

### Secure your wireless connection!

By default, the TG-789 Gateway secures your wireless data with WPA2 PSK encryption. This is the most secure encryption type that is currently available.

The wireless key used to encrypt the data is a unique sequence of ten random characters. You can find your wireless key on the bottom label of your TG-789 Gateway.

If you want to make changes to the security settings, see *"3.4 Changing the wireless security settings"* on page 24.

(E.g., [https://help.iinet.net.au/sites/default/files/2019-12/TG789\\_iiUserManual%20v2\\_0.pdf](https://help.iinet.net.au/sites/default/files/2019-12/TG789_iiUserManual%20v2_0.pdf)).

Essential		
(?)	Model name	DJA0230
(?)	Also known as	Telstra Smart Modem Gen1
(?)	RRP	\$216
(?)	Current model	✘ Replaced by the Telstra Smart Modem Gen 2

WiFi		
(?)	Default SSID	Telstraxxxxxx
(?)	Multiple SSID	✓
(?)	Access point mode	✓
(?)	Wireless client mode	N/A
(?)	Wireless bridge mode	N/A
(?)	Multipoint bridge mode	N/A
(?)	Repeater mode	N/A
(?)	WEP-64bit	N/A
(?)	WEP-128bit	N/A
(?)	WEP-256bit	N/A
(?)	WPA	✓
(?)	WPA-PSK	✓
(?)	WPA2	✓
(?)	WPA2-PSK	✓
(?)	WPS support	✓
(?)	802.11a (54 Mbps)	✓
(?)	802.11b (11 Mbps)	✓
(?)	802.11g (54 Mbps)	✓
(?)	802.11g "Super-G" (108Mbps)	✓
(?)	802.11n (2.4GHz)	✓
(?)	802.11n (5GHz)	✓
(?)	802.11ac	✓
(?)	Fastest 802.11ac supported	2133
(?)	Internal antenna(s)	4
(?)	External antenna(s)	0
(?)	External Antenna Removable?	N/A

(E.g., [https://bc.whirlpool.net.au/bc/hardware/?action=h\\_view&model\\_id=1810](https://bc.whirlpool.net.au/bc/hardware/?action=h_view&model_id=1810)).



technicolor

**MediaAccess TG1700(d)ac**  
Smart Wireless .11ac  
Integrated GPON Gateway  
with Voice

I speak  
Qeo

TELECOM  
DATA  
VOICE  
VIDEO

On the Edge with Giga-bit Speeds

## Wireless Specifications

- Full dual band concurrent Wi-Fi access points, Wi-Fi certified®
  - 2.4 GHz (2x2) IEEE 802.11n AP
  - 5.0 GHz (3x3) IEEE 802.11ac AP  
with IEEE 802.11ac compliant transmit  
beamforming
- Wi-Fi 2.4 GHz power    Standard: Up to 20dBm (100mW EIRP)  
   High Power (optional): Up to 24dBm (250mW EIRP)
- Wi-Fi Protected Setup (WPS™)
- Wi-Fi security levels    WPA2™-Enterprise / WPA™-Enterprise  
   WPA2™-Personal / WPA™-Personal  
   WEP™

(E.g.,

<https://mtc-product-specification-store->

[production.s3.amazonaws.com/1618395043882\\_TG1700%20dac.pdf](https://mtc-product-specification-store-production.s3.amazonaws.com/1618395043882_TG1700%20dac.pdf)).

# FGA5330 FGA5330TCH

## Technicolor

[device](#) > / [Wi-Fi](#) > / [WFA91325](#)

[device](#) > / [Technicolor](#) > / [FGA5330TCH](#)

XGSPON with 11ax WiFi fiber gateway

### ▼ Device Certifications

Security: Protected Management Frames	✓
Spectrum & Regulatory Features: Spectrum & Regulatory	✓
Optimization: Wi-Fi Agile Multiband™	✓
Connectivity: Wi-Fi CERTIFIED 6™	✓
Connectivity: Wi-Fi CERTIFIED™ ac	✓
Connectivity: Wi-Fi CERTIFIED™ n	✓
Optimization: WMM®	✓
Security: WPA2™-Enterprise	✓
Security: WPA2™-Personal	✓

(E.g., <https://device.report/wifi/WFA91325>).



The FGA2230TCH is a high-speed Gigabit Passive Optical Network (GPON) gateway taking advantage of the latest developments in Fiber To The Home (FTTH), while at the same time guaranteeing the highest quality of service.

(E.g., <https://fccid.io/G95FGA2230/User-Manual/User-Manual-4652062.pdf>).

## Highest Security

The FGA2230TCH Stateful Packet Inspection (SPI) firewall guarantees users the ultimate network security level. Through integration with Network Address & Port Translation (NAPT), the firewall leverages all the Application Level Gateways (ALGs) provided in the NAT context to minimize undesired service impacts.

Advanced smart parental controls, security audit services, access logging and monitoring are optionally available for home, hotspot and mobile data network users to create a fully personalized and time-based access control environment, based on individual user profiles and web usage behaviour.

The FGA2230TCH also supports powerful wireless security mechanisms, such as Wi-Fi Protected Access (WPA, WPA2) together with the secure and user friendly Wi-Fi Protected Setup (WPS) connection and configuration mechanism for connecting wireless clients.

In addition, the FGA2230TCH supports multiple wireless networks (mSSID) enabling to set up independent virtual wireless access points, including controlled wireless hotspots. These additional wireless networks allow other wireless users to enjoy high-performance access without any compromise on the integrity of the basic network, thus keeping the original network access limited and secure.

(E.g., <https://fccid.io/G95FGA2230/User-Manual/User-Manual-4652062.pdf>).



### Step 3: Configure your wireless access point

- 1 Click **Wireless**. The **Wireless** page appears.
- 2 By default, the 2.4 GHz access point is selected in the menu on the left. Change the following settings under **Access Point**:
  - a In the **SSID name** box, type the network name that you want to use for this access point (if you do not want to use the default one).
  - b In the **Security Mode** list under **Access Point**, select the security mode that you want to use for this access point. We recommend to use **WPA+WPA2-PSK**.
  - c In the **Wireless Password** box, type the wireless key that you want to use for this access point. The key must consist of 8 to 63 alphanumeric characters.
    - ! Do not use WEP or None, since they are not secure.
    - WPS will be disabled if you select WEP.
  - d Click **Save**.
- 3 In the menu on the left, click the 5 GHz access point, configure the 5 GHz wireless Access Point settings (as in step 2).
- 4 (Re)connect your wireless client(s) to the DGA4130 using the new wireless settings.

(E.g., [https://www.wind.gr/files/1/Wind\\_v2/statheri/epipleon\\_ypiresies/devices/DMS3-CTC-25-420\\_v1.0\\_public.pdf](https://www.wind.gr/files/1/Wind_v2/statheri/epipleon_ypiresies/devices/DMS3-CTC-25-420_v1.0_public.pdf)).



(E.g., <https://www.provu.co.uk/products/technicolor/DWA0120/DWA0120.pdf>).

## Highest Security

The DWA0120 Stateful Packet Inspection (SPI) firewall guarantees users the ultimate network security level. Through integration with Network Address & Port Translation (NAPT), the firewall leverages all the Application Level Gateways (ALGs) provided in the NAT context to minimize undesired service impacts.

Advanced smart parental controls, security audit services, access logging and monitoring are optionally available for home, hotspot and mobile data network users to create a fully personalized and time-based access control environment, based on individual user profiles and web usage behaviour.

The DWA0120 also supports powerful wireless security mechanisms, such as Wi-Fi Protected Access (WPA, WPA2) together with the secure and user friendly Wi-Fi Protected Setup (WPS) connection and configuration mechanism for connecting wireless clients.

In addition, the DWA0120 supports multiple wireless networks (mSSID) enabling to set up independent virtual wireless access points, including controlled wireless hotspots. These additional wireless networks allow other wireless users to enjoy high-performance access without any compromise on the integrity of the basic network, thus keeping the original network access limited and secure.

(E.g., <https://www.provu.co.uk/products/technicolor/DWA0120/DWA0120.pdf>).

## CGA0101 *Wireless Cable Gateway* Quick Installation Guide

### Check your CGA0101 Access Information

There is a label pasted to the bottom of CGA0101 case. In that label, you can obtain following information. Pls note, following label is just an example, each CGA0101 has their own label and setting value. Pls follow your label information to access and configure CGA0101. In normal case, you don't need to change anything, all setting have been set and work properly.

SSID:  
CGA0101\_8C9D

WPA2-PSK(TKIP+AES)

Web Management:  
<http://192.168.0.1>  
login: admin  
password: password

**SSID:** This is used for your CGA0101 wireless setting use, and, this setting has already been set to your CGA0101.

**WPA Pre-Shared Key:** This is the password for your wireless client when connecting to CGA0101. You will be asked to key in this password so as to connect via wireless connection.

(E.g., <https://fccid.io/RK9-CGA0101/User-Manual/Users-Manual-3398945>).

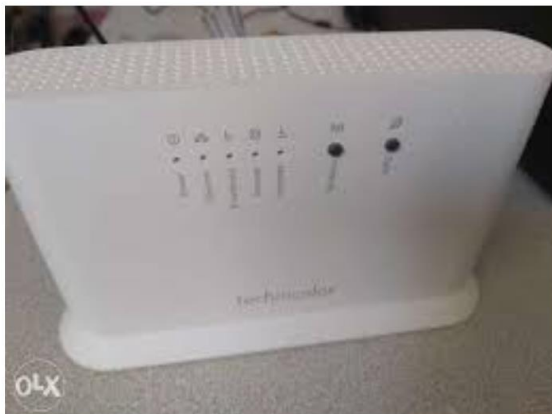

### Technicolor DWA0100 Media Access Gateway

#### Request A Quote

New © 865 Views

Sold By  
**SurpTel**

#### ABOUT THIS PRODUCT

Manufacturer Technicolor

Condition New

MPN ⓘ DWA0100

In Stock Out of Stock

0

Have Questions? ⓘ [Chat Now](#)

Technicolor Media Access Gateway. This Wireless Gateway combines the functionality of a VDSL2 / ADSL2 modem and Internet gateway in one. The various security features, such as WPS, **WPA2**, SPI, and NAT, protect your data and privacy online. The web-based utility allows you to configure your Wireless Gateway easily.

(E.g., <https://store.trustclarity.com/Technicolor-DWA0100-Media-Access-Gateway-/dp/pId=422212465085408>).



## Wi-Fi Security: WEP & WPA / WPA2

*An overview or tutorial about the IEEE 802.11 standards for Wi-Fi and WLAN applications and the associated WLAN equipment and the use of Wifi hotspots.*

---

### **WiFi IEEE 802.11 Includes:**

[Wi-Fi IEEE 802.11 introduction](#)   [Standards](#)   [Security](#)   [How to stay safe on public Wi-Fi](#)   [Wi-Fi Bands](#)  
[Router location & coverage](#)   [How to buy the best Wi-Fi router](#)   [Wi-Fi boosters, range extenders & repeaters](#)  
[Wi-Fi wired & powerline extender](#)

---

Wi-Fi network security is an issue of importance to all Wi-Fi users. It is defined under the IEEE standard 802.11i and security schemes like as WEP, WPA, WPA2 and WPA3 are widely mentioned, with keys or codes being provided for the various Wi-Fi hotspots in use.

Wi-Fi security is of significant importance because very many people use it: at home, in the office and when they are on the move. As the wireless signal can be picked up by non-authorized users, it is imperative to ensure that they cannot access the system.

Even users who legitimately gain access to a system could they try to hack other computers on the same hotspot.

(E.g., <https://www.electronics-notes.com/articles/connectivity/wifi-ieee-802-11/security-wep-wpa-wpa2.php>).

### **5.1.1.4 Interaction with other IEEE 802<sup>®</sup> layers**

IEEE Std 802.11 is required to appear to higher layers [logical link control (LLC)] as a wired IEEE 802 LAN. This requires that the IEEE 802.11 network handle STA mobility within the MAC sublayer. To meet reliability assumptions (that LLC makes about lower layers), it is necessary for IEEE Std 802.11 to incorporate functionality that is untraditional for MAC sublayers.

In a robust security network association (RSNA), IEEE Std 802.11 provides functions to protect data frames, IEEE Std 802.1X-2004 provides authentication and a Controlled Port, and IEEE Std 802.11 and IEEE Std 802.1X-2004 collaborate to provide key management. All STAs in an RSNA have a corresponding IEEE 802.1X entity that handles these services. This standard defines how an RSNA utilizes IEEE Std 802.1X-2004 to access these services.

(E.g., [https://standards.ieee.org/standard/802\\_11-2007.html](https://standards.ieee.org/standard/802_11-2007.html)).

### 5.2.3.2 RSNA

An RSNA defines a number of security features in addition to wired equivalent privacy (WEP) and IEEE 802.11 authentication. These features include the following:

- Enhanced authentication mechanisms for STAs
- Key management algorithms
- Cryptographic key establishment
- An enhanced data cryptographic encapsulation mechanism, called Counter mode with Cipher-block chaining Message authentication code Protocol (CCMP), and, optionally, Temporal Key Integrity Protocol (TKIP).

An RSNA relies on several components external to the IEEE 802.11 architecture.

The first component is an IEEE 802.1X port access entity (PAE). PAEs are present on all STAs in an RSNA and control the forwarding of data to and from the medium access control (MAC). An AP always implements the Authenticator PAE and Extensible Authentication Protocol (EAP) Authenticator roles, and a non-AP STA always implements the Supplicant PAE and EAP peer roles. In an IBSS, each STA implements both the Authenticator PAE and Supplicant PAE roles and both EAP Authenticator and EAP peer roles.

A second component is the Authentication Server (AS). The AS may authenticate the elements of the RSNA itself, i.e., the non-AP STAs; and APs may provide material that the RSNA elements can use to authenticate each other. The AS communicates through the IEEE 802.1X Authenticator with the IEEE 802.1X Supplicant on each STA, enabling the STA to be authenticated to the AS and vice versa. An RSNA depends upon the use of an EAP method that supports mutual authentication of the AS and the STA, such as those that meet the requirements in IETF RFC 4017. In certain applications, the AS may be integrated into the same physical device as the AP, or into a STA in an IBSS.

(E.g., [https://standards.ieee.org/standard/802\\_11-2007.html](https://standards.ieee.org/standard/802_11-2007.html)).

20. Upon information and belief, the system utilized by the Accused Instrumentalities practices providing a node identifier comprising an address (e.g., MAC address) and an initial authentication key (e.g., Pre-shared key or Pairwise master key). The Accused Instrumentalities provides wireless connection to accessory devices (e.g., accessory devices such as a Wi-Fi enabled smartphone, etc.) to join its Wi-Fi network. An accessory device (e.g., accessory devices such as a Wi-Fi enabled smartphone, etc.) is provided with a MAC address (i.e., address of NIC card of the accessory device) and an initial authentication key (e.g., Wi-Fi password which is a pre-shared key or pairwise master key) to join the Wi-Fi network.

## Modem Information

- ✓ DOCSIS 3.1 Dual Band 802.11-AC
- ✓ 32x8 channel bonding
- ✓ Compatible with future speed increases

## Highest Service Level

Cox Business Gigabit

## Front View



[Click to enlarge.](#)

After the cable modem is successfully registered on the network, a single solid white LED illuminates continuously to indicate that the cable modem is online and fully operational.

**Important:** After connecting the modem for the first time, wait 10-15 minutes before attempting to complete the WiFi setup or get online. Do not unplug the modem from power or factory reboot the modem during the initial 10-15 minute firmware download and modem registration process.

(E.g., <https://www.cox.com/business/support/technicolor-cga4131.html>).

**Figure 22: Wireless Security Settings**

The screenshot shows the configuration page for a Technicolor Wireless Cable Voice Gateway. The page is titled "Technicolor Wireless Cable Voice Gateway" and has a navigation menu with tabs for Status, Connection, Wireless, Security, Application, Administration, and Diagnostic. Under the "Wireless" tab, there are sub-tabs for Radio, Security, Advanced, Guest Network, MAC Control, WPS, QoS, and Hotspot. The "Security" sub-tab is selected, and the page displays settings for a "2.4GHz Wireless Network".

Network Name	1101AC-2.4
Security Mode	WPA or WPA2 Personal ▼
Encryption	AES/TKIP ▼
Network Password	***** <input type="checkbox"/> Show
Key Interval	3600 Seconds

Available settings include:

**Network Name:** The Network Name is displayed here.

**Security Mode:** Options for security settings include:

- **2.4GHz:** Open, WPA2 Personal, WPA or WPA2 Personal
- **5GHz:** Open, WPA2 Personal, WPA or WPA2 Personal

The default setting is WPA or WPA2 Personal.

(E.g., <https://www.cox.com/content/dam/cox/business/documents/internet/CBIG%204131%20User%20Guide.pdf>).

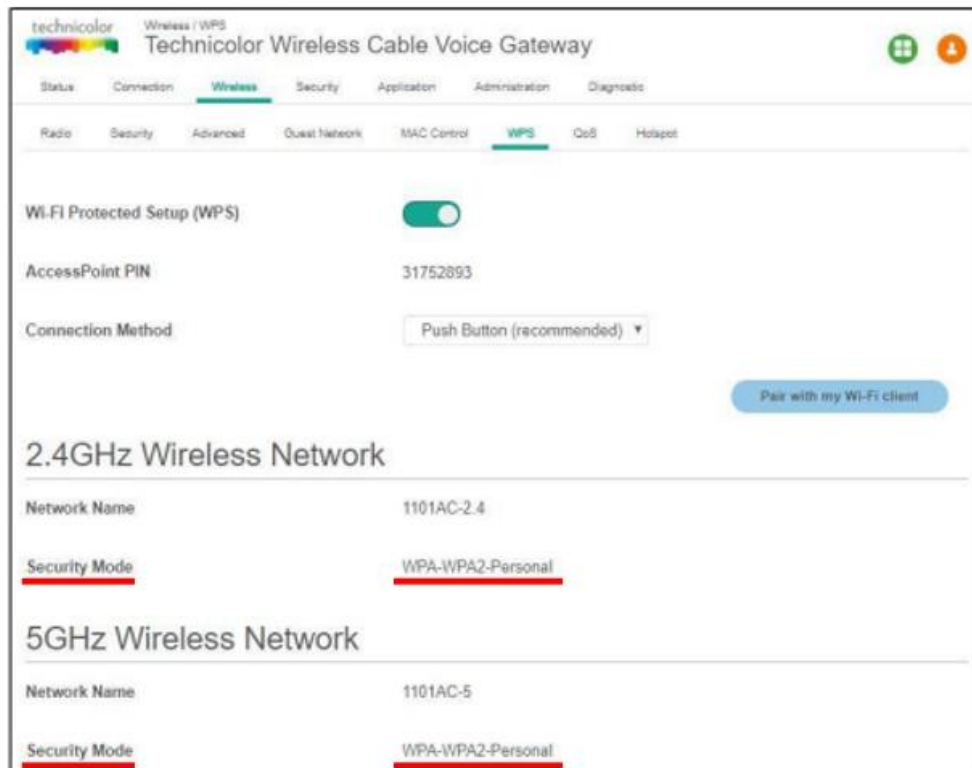
**Figure 23: WPS Settings**

## ***Prevent Devices from Accessing Your Wireless Network***

### **MAC Address**

A MAC (Media Access Control) address is a unique hexadecimal code that identifies a device on a network. Each network-enabled device has at least one unique MAC address.

For example, if your computer is equipped with an Ethernet and a wireless network adaptor, each of these interfaces will have its own MAC address.

(E.g., <https://www.cox.com/content/dam/cox/business/documents/internet/CBIG%204131%20User%20Guide.pdf>).

**Figure 24: Device Filter Settings**

technicolor Security / Device Filter  
Technicolor Wireless Cable Voice Gateway

Status Connection Wireless **Security** Application Administration Diagnostic

Firewall IP Filter **Device Filter** Access Control Service Filter VPN Email Settings Report

Device Filter

Access Type  Allow All  Block All

### Blocked Devices

Computer Name	MAC Address	When Block	Delete
+			

### Devices

Computer Name	MAC Address	Status	Operation
dinesh_g	8c:ec:4b:40:18:7d		+
iPhone	B0:19:C6:BB:3D:2D		+

(E.g., <https://www.cox.com/content/dam/cox/business/documents/internet/CBIG%204131%20User%20Guide.pdf>).

So not surprisingly, along with an IP address (which is networks software), there's also a hardware address. Typically it is tied to a key connection device in your computer called the network interface card, or NIC. The NIC is essentially a computer circuit card that makes it possible for your computer to connect to a network.

An NIC turns data into an electrical signal that can be transmitted over the network.

## Hey Nick. Meet Mac.

Every NIC has a hardware address that's known as a MAC, for Media Access Control. Where IP addresses are associated with TCP/IP (networking software), MAC addresses are linked to the hardware of network adapters.

A MAC address is given to a network adapter when it is manufactured. It is hardwired or hard-coded onto your computer's network interface card (NIC) and is unique to it. Something called the ARP (Address Resolution Protocol) translates an IP address into a MAC address. The ARP is like a passport that takes data from an IP address through an actual piece of computer hardware.

(E.g., <https://whatismyipaddress.com/mac-address>).

- 802.11 frames have up to four address fields in the MAC header.
- 802.11 frames typically use only three of the MAC address fields (4 in WDS environment).

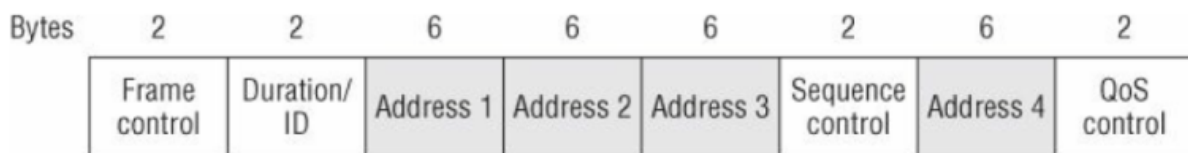

**Figure 9.3** 802.11 MAC header

(E.g., <https://dot11ap.wordpress.com/ieee-802-11-frame-format-vs-ieee-802-3-frame-format/>).

Depending on whether the 802.11 traffic is upstream or downstream, the definition of each of the four MAC address fields in the layer 2 header will change.

The five definitions are as follows:

- **Source Address (SA)** The MAC address of the original sending station is known as the SA. The source address can originate from either a wireless station or the wired network.
- **Destination Address (DA)** The MAC address that is the final destination of the layer 2 frame is known as the DA. The final destination may be a wireless station or could be a destination on the wired network such as a server or a router.

(E.g., <https://dot11ap.wordpress.com/ieee-802-11-frame-format-vs-ieee-802-3-frame-format/>).

## WPA-PSK

WPA-PSK uses this kind of key-encryption system to protect Wi-Fi networks. When you set a WPA-PSK password on the router, you are actually setting the key which the WPA standard will use to encrypt data. When users type in this matching key as their "password" their computers will be able to communicate with the router. Otherwise, they can't join the network because their computers will be incapable of understanding anything the router sends them. There is no such thing as a "default" key in key-based encryption methods. If your router is broadcasting with WPA-PSK, it means that someone with administrative access to the router enabled encryption with a key of his own choosing.

(E.g., <https://smallbusiness.chron.com/default-wpapsk-wifi-39458.html>).

IEEE 802.11 defines two authentication methods: Open System authentication and Shared Key authentication. Open System authentication admits any STA to the DS. Shared Key authentication relies on WEP to demonstrate knowledge of a WEP encryption key. The IEEE 802.11 authentication mechanism also allows definition of new authentication methods.

An RSNA also supports authentication based on IEEE 802.1X, or preshared keys (PSKs). IEEE 802.1X authentication utilizes the EAP to authenticate STAs and the AS with one another. This amendment does not specify an EAP method that is mandatory to implement. See 8.4.4 for a description of the IEEE 802.1X authentication and PSK usage within an IEEE 802.11 IBSS.

In an RSNA, IEEE 802.1X Supplicants and Authenticators exchange protocol information via the IEEE 802.1X Uncontrolled Port. The IEEE 802.1X Controlled Port is blocked from passing general data traffic between two STAs until an IEEE 802.1X authentication procedure completes successfully over the IEEE 802.1X Uncontrolled Port.

(E.g., IEEE 802.11i).



### 5.9.2.2 Operations with PSK

The following AKM operations are carried out when the PMK is a PSK:

- A STA discovers the AP's security policy through passively monitoring Beacon frames or through active probing (shown in Figure 11a). A STA associates with an AP and negotiates a security policy. The PMK is the PSK.
- The 4-Way Handshake using EAPOL-Key frames is used just as with IEEE 802.1X authentication, when an AS is present. See Figure 11c.
- The GTK and GTK sequence number are sent from the Authenticator to the Supplicant just as in the AS case. See Figure 11c and Figure 11d.

(E.g., IEEE 802.11i).

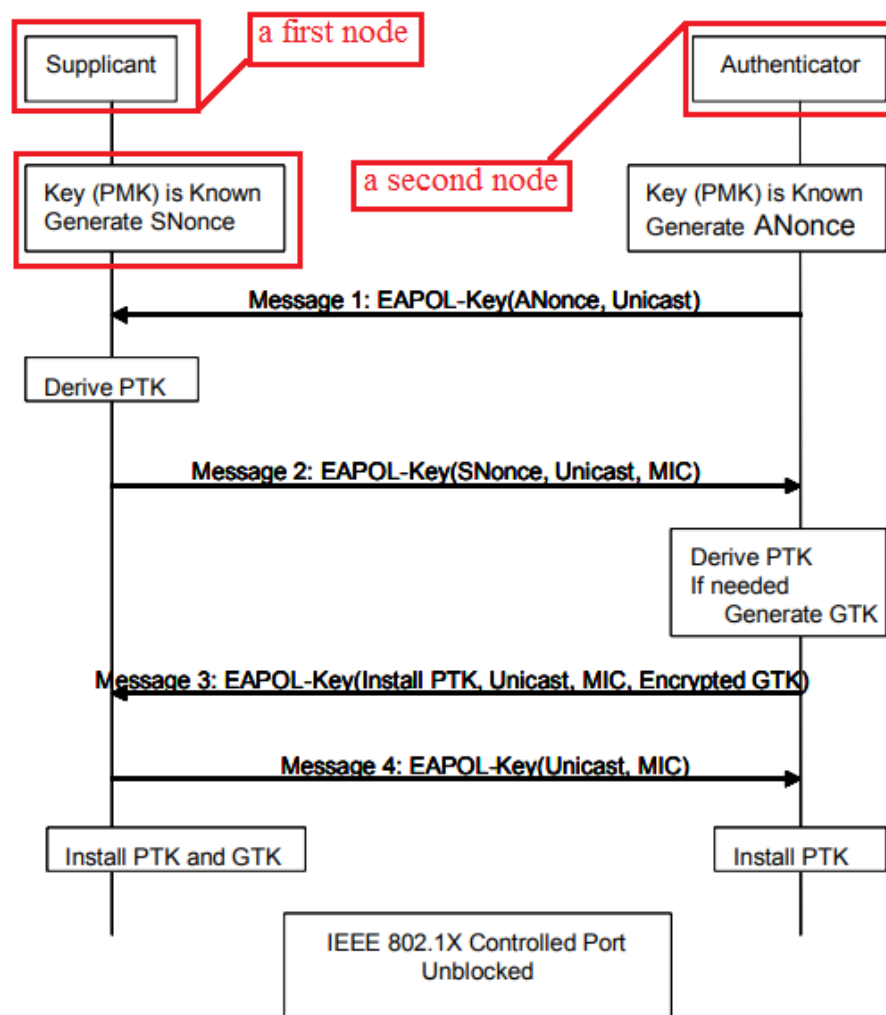

(E.g., IEEE 802.11i).

- b) If an RSNA is based on a PSK in an ESS, the STA's SME establishes an RSNA as follows:
- 1) It identifies the AP as RSNA-capable from the AP's Beacon or Probe Response frames.
  - 2) It shall invoke Open System authentication.
  - 3) It negotiates cipher suites during the association process, as described in 8.4.2 and 8.4.3.
  - 4) It establishes temporal keys by executing a key management algorithm, using the protocol defined by 8.5. It uses the PSK as the PMK.
  - 5) It protects the data link by programming the negotiated cipher suites and the established temporal key into the MAC and then invoking protection.
- c) If an RSNA is based on a PSK in an IBSS, the STA's SME executes the following sequence of procedures:
- 1) It identifies the peer as RSNA-capable from the peer's Beacon or Probe Response frames.  
  
NOTE—STAs may respond to a data MPDU from an unrecognized STA by sending a Probe Request frame to find out whether the unrecognized STA is RSNA-capable.
  - 2) It may optionally invoke Open System authentication.
  - 3) Each STA uses the procedures in 8.5, to establish temporal keys and to negotiate cipher suites. It uses a PSK as the PMK. Note that two peer STAs may follow this procedure simultaneously. See 8.4.9.
  - 4) It protects the data link by programming the negotiated cipher suites and the established temporal key and then invoking protection.

(E.g., IEEE 802.11i).

21. Upon information and belief, the system utilized by the Accused Instrumentalities practices installing the node identifier (e.g., MAC address and pre-shared key or pairwise master key) at a first network node (e.g., accessory devices such as a Wi-Fi enabled smartphone, etc.). A MAC address of an accessory device is a hardware address of a network interface card of an accessory device (e.g., accessory device such as a Wi-Fi enabled smartphone, etc.). Also, the accessory device needs to utilize a Wi-Fi password which is pre-shared key or pairwise master key (e.g., initial authentication key) of the wireless connection of the Accused Instrumentalities to join the Wi-Fi network. Upon information and belief, the accessory device enters or installs the Wi-Fi password as well as the MAC address in the Wi-Fi stack of the accessory device to initiate an association process with the Wi-Fi network of the Accused Instrumentalities.

## Modem Information

- ✓ DOCSIS 3.1 Dual Band 802.11-AC
- ✓ 32x8 channel bonding
- ✓ Compatible with future speed increases

## Highest Service Level

Cox Business Gigabit

## Front View

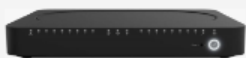

[Click to enlarge.](#)

After the cable modem is successfully registered on the network, a single solid white LED illuminates continuously to indicate that the cable modem is online and fully operational.

**Important:** After connecting the modem for the first time, wait 10-15 minutes before attempting to complete the WiFi setup or get online. Do not unplug the modem from power or factory reboot the modem during the initial 10-15 minute firmware download and modem registration process.

(E.g., <https://www.cox.com/business/support/technicolor-cga4131.html>).

**Figure 22: Wireless Security Settings**

The screenshot displays the 'Wireless / Security' configuration page for a Technicolor Wireless Cable Voice Gateway. The page is titled '2.4GHz Wireless Network' and shows the following settings:

Setting	Value
Network Name	1101AC-2.4
Security Mode	WPA or WPA2 Personal
Encryption	AES/TKIP
Network Password	***** (with a 'Show' toggle)
Key Interval	3600 Seconds

Available settings include:

**Network Name:** The Network Name is displayed here.

**Security Mode:** Options for security settings include:

- **2.4GHz:** Open, WPA2 Personal, WPA or WPA2 Personal
- **5GHz:** Open, WPA2 Personal, WPA or WPA2 Personal

The default setting is WPA or WPA2 Personal.

(E.g., <https://www.cox.com/content/dam/cox/business/documents/internet/CBIG%204131%20User%20Guide.pdf>).

**Figure 23: WPS Settings**

technicolor Wireless | WPS  
Technicolor Wireless Cable Voice Gateway

Status Connection **Wireless** Security Application Administration Diagnostic

Radio Security Advanced Guest Network MAC Control **WPS** CoS Hotspot

Wi-Fi Protected Setup (WPS)

AccessPoint PIN 31752893

Connection Method Push Button (recommended) ▼

Pair with my Wi-Fi client

**2.4GHz Wireless Network**

Network Name 1101AC-2.4

Security Mode WPA-WPA2-Personal

**5GHz Wireless Network**

Network Name 1101AC-5

Security Mode WPA-WPA2-Personal

## ***Prevent Devices from Accessing Your Wireless Network***

### **MAC Address**

A MAC (Media Access Control) address is a unique hexadecimal code that identifies a device on a network. Each network-enabled device has at least one unique MAC address.

For example, if your computer is equipped with an Ethernet and a wireless network adaptor, each of these interfaces will have its own MAC address.

(E.g., <https://www.cox.com/content/dam/cox/business/documents/internet/CBIG%204131%20User%20Guide.pdf>).

**Figure 24: Device Filter Settings**

technicolor Security / Device Filter  
Technicolor Wireless Cable Voice Gateway

Status Connection Wireless **Security** Application Administration Diagnostic

Firewall IP Filter **Device Filter** Access Control Service Filter VPN Email Settings Report

Device Filter

Access Type  Allow All  Block All

### Blocked Devices

Computer Name	MAC Address	When Block	Delete
+			

### Devices

Computer Name	MAC Address	Status	Operation
dinesh_g	8c:ec:4b:40:18:7d		+
iPhone	B0:19:C6:BB:3D:2D		+

(E.g., <https://www.cox.com/content/dam/cox/business/documents/internet/CBIG%204131%20User%20Guide.pdf>).

So not surprisingly, along with an IP address (which is networks software), there's also a hardware address. Typically it is tied to a key connection device in your computer called the network interface card, or NIC. The NIC is essentially a computer circuit card that makes it possible for your computer to connect to a network.

An NIC turns data into an electrical signal that can be transmitted over the network.

## Hey Nick. Meet Mac.

Every NIC has a hardware address that's known as a MAC, for Media Access Control. Where IP addresses are associated with TCP/IP (networking software), MAC addresses are linked to the hardware of network adapters.

A MAC address is given to a network adapter when it is manufactured. It is hardwired or hard-coded onto your computer's network interface card (NIC) and is unique to it. Something called the ARP (Address Resolution Protocol) translates an IP address into a MAC address. The ARP is like a passport that takes data from an IP address through an actual piece of computer hardware.

(E.g., <https://whatismyipaddress.com/mac-address>).

- 802.11 frames have up to four address fields in the MAC header.
- 802.11 frames typically use only three of the MAC address fields (4 in WDS environment).

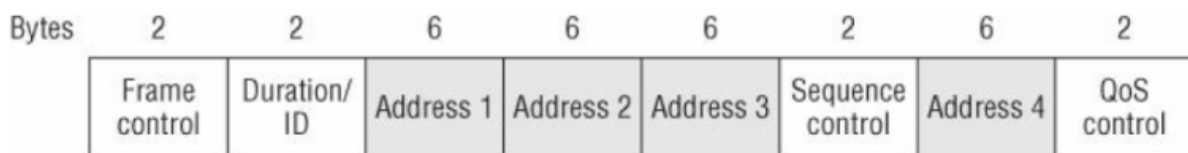

**Figure 9.3** 802.11 MAC header

(E.g., <https://dot11ap.wordpress.com/ieee-802-11-frame-format-vs-ieee-802-3-frame-format/>).

Depending on whether the 802.11 traffic is upstream or downstream, the definition of each of the four MAC address fields in the layer 2 header will change.

The five definitions are as follows:

- **Source Address (SA)** The MAC address of the original sending station is known as the SA. The source address can originate from either a wireless station or the wired network.
- **Destination Address (DA)** The MAC address that is the final destination of the layer 2 frame is known as the DA. The final destination may be a wireless station or could be a destination on the wired network such as a server or a router.

(E.g., <https://dot11ap.wordpress.com/ieee-802-11-frame-format-vs-ieee-802-3-frame-format/>).

## WPA-PSK

WPA-PSK uses this kind of key-encryption system to protect Wi-Fi networks. When you set a WPA-PSK password on the router, you are actually setting the key which the WPA standard will use to encrypt data. When users type in this matching key as their "password" their computers will be able to communicate with the router. Otherwise, they can't join the network because their computers will be incapable of understanding anything the router sends them. There is no such thing as a "default" key in key-based encryption methods. If your router is broadcasting with WPA-PSK, it means that someone with administrative access to the router enabled encryption with a key of his own choosing.

(E.g., <https://smallbusiness.chron.com/default-wpapsk-wifi-39458.html>).

IEEE 802.11 defines two authentication methods: Open System authentication and Shared Key authentication. Open System authentication admits any STA to the DS. Shared Key authentication relies on WEP to demonstrate knowledge of a WEP encryption key. The IEEE 802.11 authentication mechanism also allows definition of new authentication methods.

An RSNA also supports authentication based on IEEE 802.1X, or preshared keys (PSKs). IEEE 802.1X authentication utilizes the EAP to authenticate STAs and the AS with one another. This amendment does not specify an EAP method that is mandatory to implement. See 8.4.4 for a description of the IEEE 802.1X authentication and PSK usage within an IEEE 802.11 IBSS.

In an RSNA, IEEE 802.1X Supplicants and Authenticators exchange protocol information via the IEEE 802.1X Uncontrolled Port. The IEEE 802.1X Controlled Port is blocked from passing general data traffic between two STAs until an IEEE 802.1X authentication procedure completes successfully over the IEEE 802.1X Uncontrolled Port.

(E.g., IEEE 802.11i).



### 5.9.2.2 Operations with PSK

The following AKM operations are carried out when the PMK is a PSK:

- A STA discovers the AP's security policy through passively monitoring Beacon frames or through active probing (shown in Figure 11a). A STA associates with an AP and negotiates a security policy. The PMK is the PSK.
- The 4-Way Handshake using EAPOL-Key frames is used just as with IEEE 802.1X authentication, when an AS is present. See Figure 11c.
- The GTK and GTK sequence number are sent from the Authenticator to the Supplicant just as in the AS case. See Figure 11c and Figure 11d.

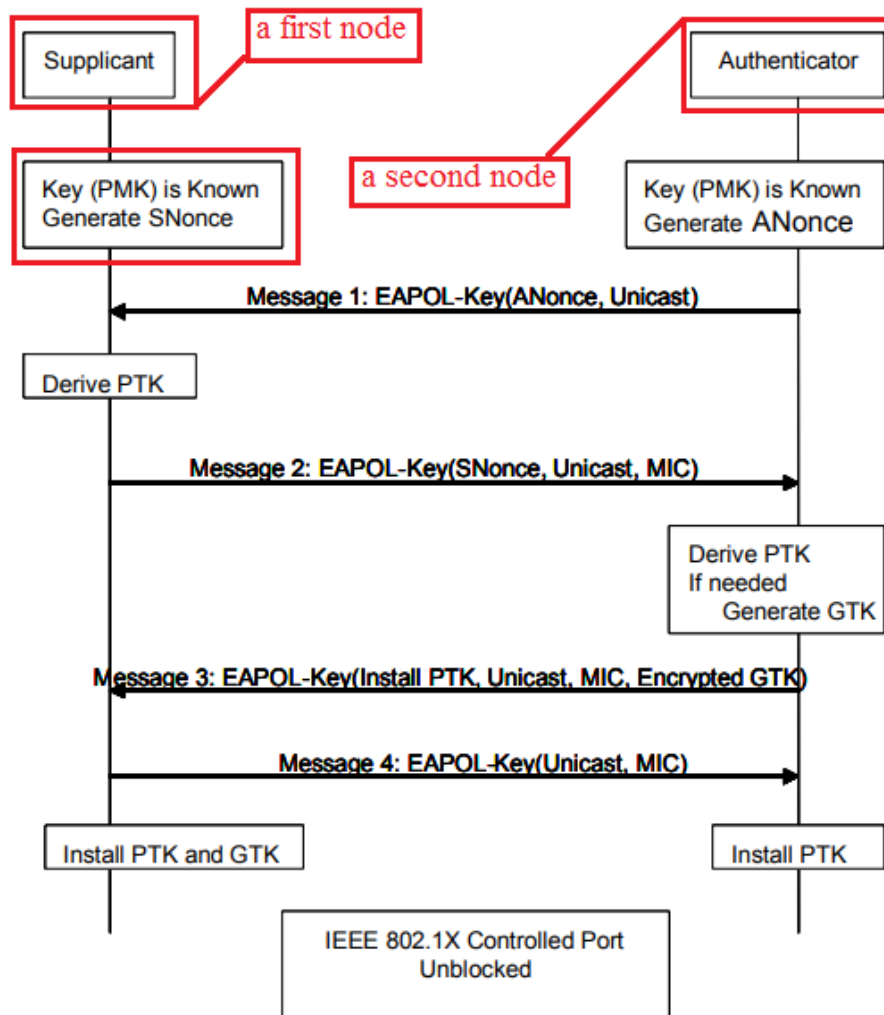

(E.g., IEEE 802.11i).

- b) If an RSNA is based on a PSK in an ESS, the STA's SME establishes an RSNA as follows:
- 1) It identifies the AP as RSNA-capable from the AP's Beacon or Probe Response frames.
  - 2) It shall invoke Open System authentication.
  - 3) It negotiates cipher suites during the association process, as described in 8.4.2 and 8.4.3.
  - 4) It establishes temporal keys by executing a key management algorithm, using the protocol defined by 8.5. It uses the PSK as the PMK.
  - 5) It protects the data link by programming the negotiated cipher suites and the established temporal key into the MAC and then invoking protection.
- c) If an RSNA is based on a PSK in an IBSS, the STA's SME executes the following sequence of procedures:
- 1) It identifies the peer as RSNA-capable from the peer's Beacon or Probe Response frames.  
  
NOTE—STAs may respond to a data MPDU from an unrecognized STA by sending a Probe Request frame to find out whether the unrecognized STA is RSNA-capable.
  - 2) It may optionally invoke Open System authentication.
  - 3) Each STA uses the procedures in 8.5, to establish temporal keys and to negotiate cipher suites. It uses a PSK as the PMK. Note that two peer STAs may follow this procedure simultaneously. See 8.4.9.
  - 4) It protects the data link by programming the negotiated cipher suites and the established temporal key and then invoking protection.

(*E.g.*, IEEE 802.11i).

22. Upon information and belief, the system utilized by the Accused Instrumentalities practices storing the node identifier (*e.g.*, MAC address of an accessory device and pre-shared key or pairwise master key) at a second network node (*e.g.*, the Accused Instrumentalities). The Accused Instrumentalities stores MAC address of an accessory device and the pre-shared key or pairwise master key. To join the Wi-Fi network of the Accused Instrumentalities, an accessory device transmits a response for a beacon transmitted by the Accused Instrumentalities or sends a probe request to the Accused Instrumentalities. A Wi-Fi header comprises MAC address of a sender. The accessory device must send its MAC address. The Accused Instrumentalities receives and stores the MAC address of the accessory device. Also, the Accused Instrumentalities stores

the Wi-Fi password which is pre-shared key or pairwise master key (e.g., initial authentication key) of its wireless personal network.

## Modem Information

- ✓ DOCSIS 3.1 Dual Band 802.11-AC
- ✓ 32x8 channel bonding
- ✓ Compatible with future speed increases

## Highest Service Level

Cox Business Gigabit

## Front View

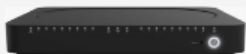

[Click to enlarge.](#)

After the cable modem is successfully registered on the network, a single solid white LED illuminates continuously to indicate that the cable modem is online and fully operational.

**Important:** After connecting the modem for the first time, wait 10-15 minutes before attempting to complete the WiFi setup or get online. Do not unplug the modem from power or factory reboot the modem during the initial 10-15 minute firmware download and modem registration process.

(E.g., <https://www.cox.com/business/support/technicolor-cga4131.html>).

**Figure 22: Wireless Security Settings**

The screenshot displays the 'Technicolor Wireless Cable Voice Gateway' configuration interface. The 'Wireless' tab is selected, and the 'Security' sub-tab is active. The settings for the '2.4GHz Wireless Network' are as follows:

Setting	Value
Network Name	1101AC-2.4
Security Mode	WPA or WPA2 Personal
Encryption	AES/TKIP
Network Password	***** (with a 'Show' toggle)
Key Interval	3600 Seconds

Available settings include:

**Network Name:** The Network Name is displayed here.

**Security Mode:** Options for security settings include:

- **2.4GHz:** Open, WPA2 Personal, WPA or WPA2 Personal
- **5GHz:** Open, WPA2 Personal, WPA or WPA2 Personal

The default setting is WPA or WPA2 Personal.

(E.g., <https://www.cox.com/content/dam/cox/business/documents/internet/CBIG%204131%20User%20Guide.pdf>).

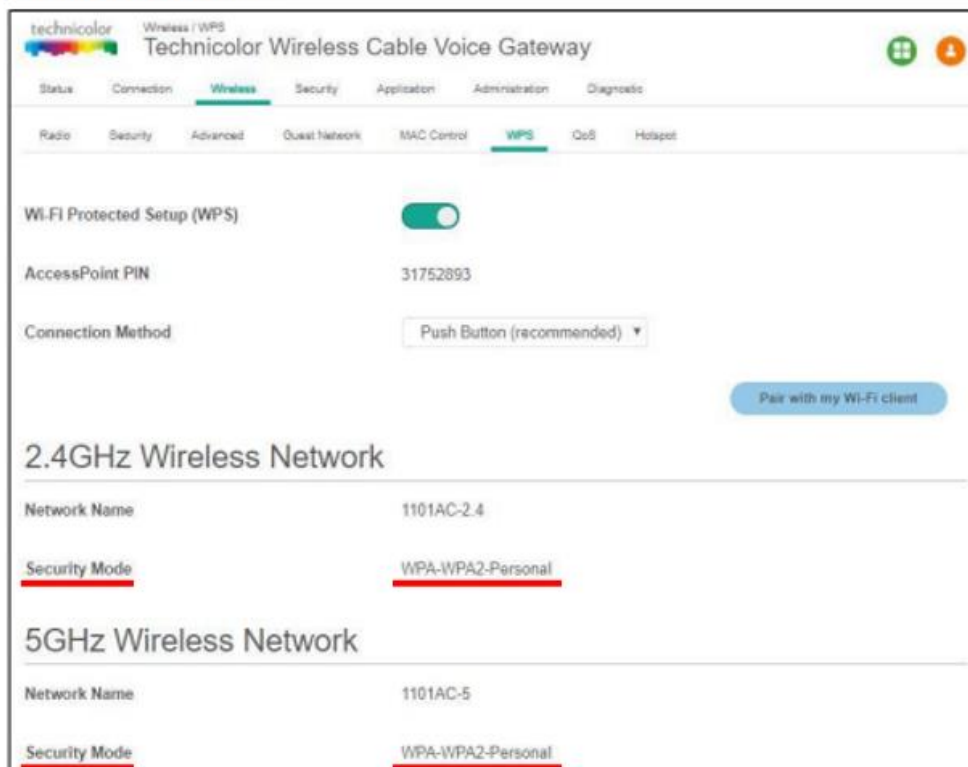
**Figure 23: WPS Settings**

## ***Prevent Devices from Accessing Your Wireless Network***

### **MAC Address**

A MAC (Media Access Control) address is a unique hexadecimal code that identifies a device on a network. Each network-enabled device has at least one unique MAC address.

For example, if your computer is equipped with an Ethernet and a wireless network adaptor, each of these interfaces will have its own MAC address.

(E.g., <https://www.cox.com/content/dam/cox/business/documents/internet/CBIG%204131%20User%20Guide.pdf>).

**Figure 24: Device Filter Settings**

technicolor Security / Device Filter  
Technicolor Wireless Cable Voice Gateway

Status Connection Wireless **Security** Application Administration Diagnostic

Firewall IP Filter **Device Filter** Access Control Service Filter VPN Email Settings Report

Device Filter

Access Type  Allow All  Block All

### Blocked Devices

Computer Name	MAC Address	When Block	Delete
+			

### Devices

Computer Name	MAC Address	Status	Operation
dinesh_g	8c:ec:4b:40:18:7d		+
iPhone	B0:19:C6:BB:3D:2D		+

(E.g., <https://www.cox.com/content/dam/cox/business/documents/internet/CBIG%204131%20User%20Guide.pdf>).

So not surprisingly, along with an IP address (which is networks software), there's also a hardware address. Typically it is tied to a key connection device in your computer called the network interface card, or NIC. The NIC is essentially a computer circuit card that makes it possible for your computer to connect to a network.

An NIC turns data into an electrical signal that can be transmitted over the network.

## Hey Nick. Meet Mac.

Every NIC has a hardware address that's known as a MAC, for Media Access Control. Where IP addresses are associated with TCP/IP (networking software), MAC addresses are linked to the hardware of network adapters.

A MAC address is given to a network adapter when it is manufactured. It is hardwired or hard-coded onto your computer's network interface card (NIC) and is unique to it. Something called the ARP (Address Resolution Protocol) translates an IP address into a MAC address. The ARP is like a passport that takes data from an IP address through an actual piece of computer hardware.

(E.g., <https://whatismyipaddress.com/mac-address>).

### 5.9.2.2 Operations with PSK

The following AKM operations are carried out when the PMK is a PSK:

- A STA discovers the AP's security policy through passively monitoring Beacon frames or through active probing (shown in Figure 11a). A STA associates with an AP and negotiates a security policy. The PMK is the PSK.
- The 4-Way Handshake using EAPOL-Key frames is used just as with IEEE 802.1X authentication, when an AS is present. See Figure 11c.
- The GTK and GTK sequence number are sent from the Authenticator to the Supplicant just as in the AS case. See Figure 11c and Figure 11d.

(E.g., IEEE 802.11i).

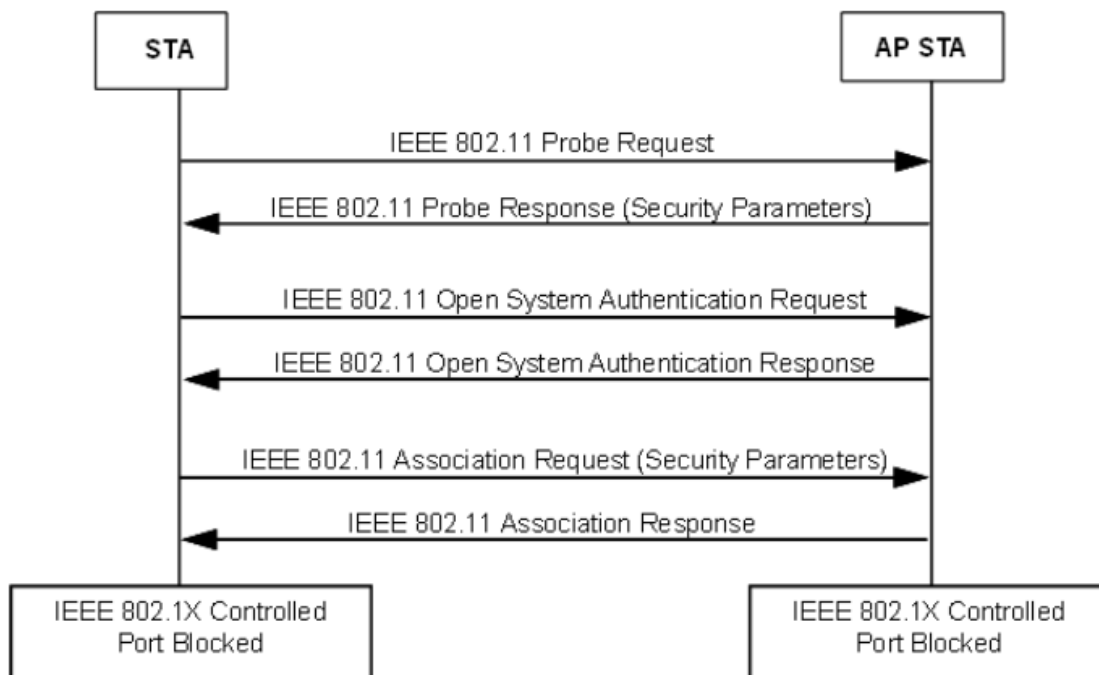

(E.g., IEEE 802.11i).

- 802.11 frames have up to four address fields in the MAC header.
- 802.11 frames typically use only three of the MAC address fields (4 in WDS environment).

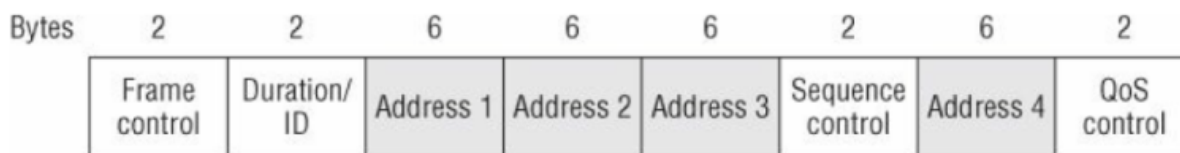

**Figure 9.3** 802.11 MAC header

(E.g., <https://dot11ap.wordpress.com/ieee-802-11-frame-format-vs-ieee-802-3-frame-format/>).



Depending on whether the 802.11 traffic is upstream or downstream, the definition of each of the four MAC address fields in the layer 2 header will change.

The five definitions are as follows:

- **Source Address (SA)** The MAC address of the original sending station is known as the SA. The source address can originate from either a wireless station or the wired network.
- **Destination Address (DA)** The MAC address that is the final destination of the layer 2 frame is known as the DA. The final destination may be a wireless station or could be a destination on the wired network such as a server or a router.

(E.g., <https://dot11ap.wordpress.com/ieee-802-11-frame-format-vs-ieee-802-3-frame-format/>).

## WPA-PSK

WPA-PSK uses this kind of key-encryption system to protect Wi-Fi networks. When you set a WPA-PSK password on the router, you are actually setting the key which the WPA standard will use to encrypt data. When users type in this matching key as their "password" their computers will be able to communicate with the router. Otherwise, they can't join the network because their computers will be incapable of understanding anything the router sends them. There is no such thing as a "default" key in key-based encryption methods. If your router is broadcasting with WPA-PSK, it means that someone with administrative access to the router enabled encryption with a key of his own choosing.

(E.g., <https://smallbusiness.chron.com/default-wpapsk-wifi-39458.html>).

IEEE 802.11 defines two authentication methods: Open System authentication and Shared Key authentication. Open System authentication admits any STA to the DS. Shared Key authentication relies on WEP to demonstrate knowledge of a WEP encryption key. The IEEE 802.11 authentication mechanism also allows definition of new authentication methods.

An RSNA also supports authentication based on IEEE 802.1X, or preshared keys (PSKs). IEEE 802.1X authentication utilizes the EAP to authenticate STAs and the AS with one another. This amendment does not specify an EAP method that is mandatory to implement. See 8.4.4 for a description of the IEEE 802.1X authentication and PSK usage within an IEEE 802.11 IBSS.

In an RSNA, IEEE 802.1X Supplicants and Authenticators exchange protocol information via the IEEE 802.1X Uncontrolled Port. The IEEE 802.1X Controlled Port is blocked from passing general data traffic between two STAs until an IEEE 802.1X authentication procedure completes successfully over the IEEE 802.1X Uncontrolled Port.

(E.g., IEEE 802.11i).

### 5.9.2.2 Operations with PSK

The following AKM operations are carried out when the PMK is a PSK:

- A STA discovers the AP's security policy through passively monitoring Beacon frames or through active probing (shown in Figure 11a). A STA associates with an AP and negotiates a security policy. The PMK is the PSK.
- The 4-Way Handshake using EAPOL-Key frames is used just as with IEEE 802.1X authentication, when an AS is present. See Figure 11c.
- The GTK and GTK sequence number are sent from the Authenticator to the Supplicant just as in the AS case. See Figure 11c and Figure 11d.

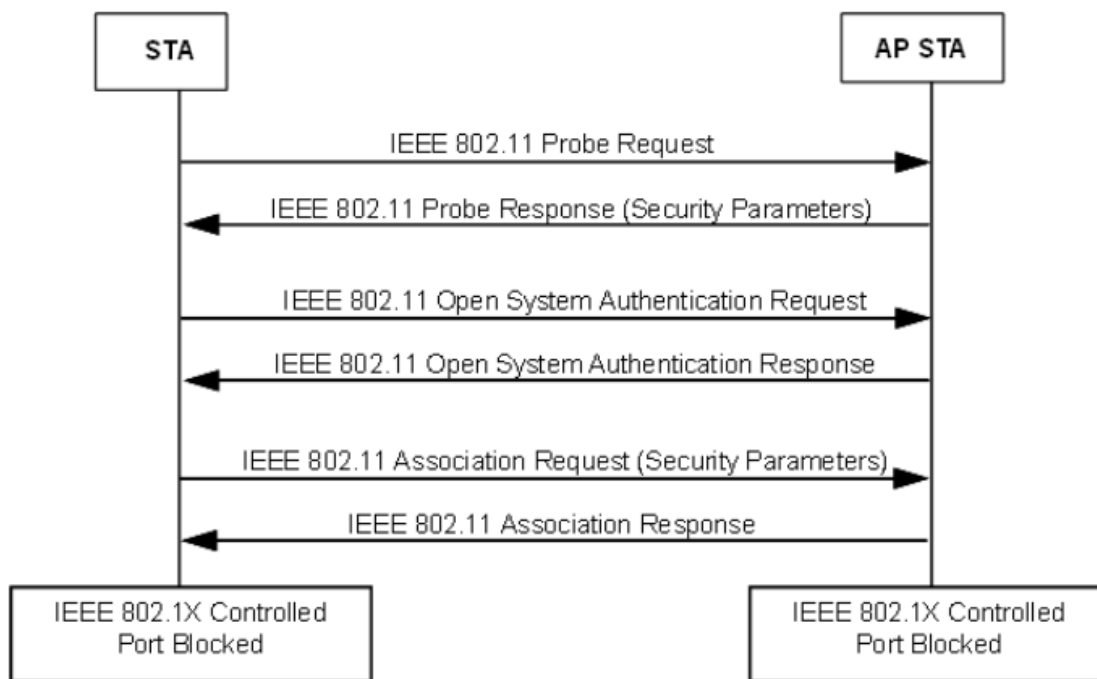

(E.g., IEEE 802.11i).

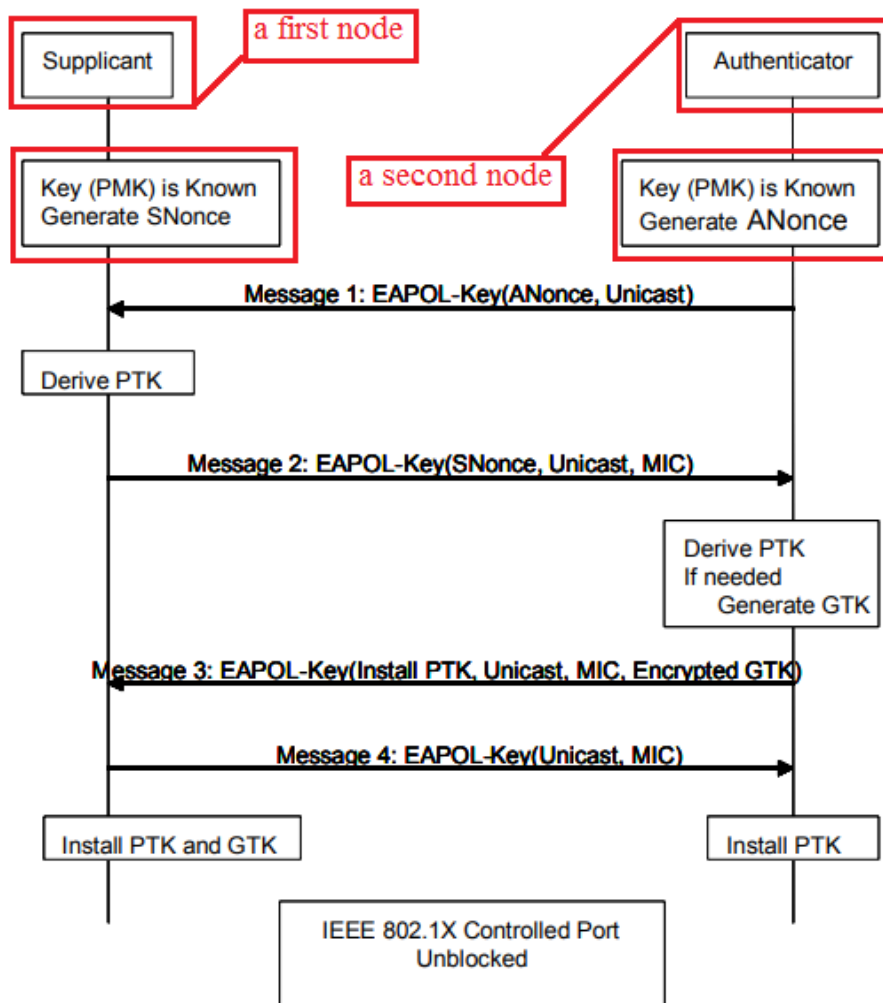

(E.g., IEEE 802.11i).

- b) If an RSNA is based on a PSK in an ESS, the STA's SME establishes an RSNA as follows:
- 1) It identifies the AP as RSNA-capable from the AP's Beacon or Probe Response frames.
  - 2) It shall invoke Open System authentication.
  - 3) It negotiates cipher suites during the association process, as described in 8.4.2 and 8.4.3.
  - 4) It establishes temporal keys by executing a key management algorithm, using the protocol defined by 8.5. It uses the PSK as the PMK.
  - 5) It protects the data link by programming the negotiated cipher suites and the established temporal key into the MAC and then invoking protection.
- c) If an RSNA is based on a PSK in an IBSS, the STA's SME executes the following sequence of procedures:
- 1) It identifies the peer as RSNA-capable from the peer's Beacon or Probe Response frames.  
  
NOTE—STAs may respond to a data MPDU from an unrecognized STA by sending a Probe Request frame to find out whether the unrecognized STA is RSNA-capable.
  - 2) It may optionally invoke Open System authentication.
  - 3) Each STA uses the procedures in 8.5, to establish temporal keys and to negotiate cipher suites. It uses a PSK as the PMK. Note that two peer STAs may follow this procedure simultaneously. See 8.4.9.
  - 4) It protects the data link by programming the negotiated cipher suites and the established temporal key and then invoking protection.

(*E.g.*, IEEE 802.11i).

23. Upon information and belief, the system utilized by the Accused Instrumentalities practices sending node identifier information (*e.g.*, MAC address of an accessory device and pre-shared key or pairwise master key) from a first network node (*e.g.*, an accessory device such as a Wi-Fi enabled smartphone, etc.) to a second network node (*e.g.*, the Accused Instrumentalities). The accessory device sends its MAC address (*e.g.*, address) as well as a key value derived from the pre-shared key or pairwise master key (*e.g.*, initial authentication key) to the Accused Instrumentalities for authentication to connect to Wi-Fi network of the Accused Instrumentalities. A pairwise temporal key is derived from the pre-shared key or pairwise master key (*e.g.*, initial authentication key). The pairwise temporal key has two parts KCK and KEK. In the authentication process, the accessory device acts as a supplicant. As shown below, the accessory device transfers a key value derived from KCK in the EAPOL-message 2 to the Accused Instrumentalities.

## Modem Information

- ✓ DOCSIS 3.1 Dual Band 802.11-AC
- ✓ 32x8 channel bonding
- ✓ Compatible with future speed increases

## Highest Service Level

Cox Business Gigabit

## Front View

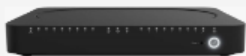

[Click to enlarge.](#)

After the cable modem is successfully registered on the network, a single solid white LED illuminates continuously to indicate that the cable modem is online and fully operational.

**Important:** After connecting the modem for the first time, wait 10-15 minutes before attempting to complete the WiFi setup or get online. Do not unplug the modem from power or factory reboot the modem during the initial 10-15 minute firmware download and modem registration process.

(E.g., <https://www.cox.com/business/support/technicolor-cga4131.html>).

**Figure 22: Wireless Security Settings**

The screenshot shows the 'Technicolor Wireless Cable Voice Gateway' configuration interface. The 'Wireless' tab is selected, and the 'Security' sub-tab is active. The settings for the '2.4GHz Wireless Network' are as follows:

Setting	Value
Network Name	1101AC-2.4
Security Mode	WPA or WPA2 Personal
Encryption	AES/TKIP
Network Password	***** (with a 'Show' toggle)
Key Interval	3600 Seconds

Available settings include:

**Network Name:** The Network Name is displayed here.

**Security Mode:** Options for security settings include:

- **2.4GHz:** Open, WPA2 Personal, WPA or WPA2 Personal
- **5GHz:** Open, WPA2 Personal, WPA or WPA2 Personal

The default setting is WPA or WPA2 Personal.

(E.g., <https://www.cox.com/content/dam/cox/business/documents/internet/CBIG%204131%20User%20Guide.pdf>).

**Figure 23: WPS Settings**

technicolor Wireless (WPS) Technicolor Wireless Cable Voice Gateway

Status Connection **Wireless** Security Application Administration Diagnostic

Radio Security Advanced Guest Network MAC Control **WPS** CoS Hotspot

Wi-Fi Protected Setup (WPS)

AccessPoint PIN 31752893

Connection Method Push Button (recommended) ▼

Pair with my Wi-Fi client

### 2.4GHz Wireless Network

Network Name 1101AC-2.4

Security Mode WPA-WPA2-Personal

### 5GHz Wireless Network

Network Name 1101AC-5

Security Mode WPA-WPA2-Personal

## ***Prevent Devices from Accessing Your Wireless Network***

### **MAC Address**

A MAC (Media Access Control) address is a unique hexadecimal code that identifies a device on a network. Each network-enabled device has at least one unique MAC address.

For example, if your computer is equipped with an Ethernet and a wireless network adaptor, each of these interfaces will have its own MAC address.

(E.g., <https://www.cox.com/content/dam/cox/business/documents/internet/CBIG%204131%20User%20Guide.pdf>).

IEEE 802.11 defines two authentication methods: Open System authentication and Shared Key authentication. Open System authentication admits any STA to the DS. Shared Key authentication relies on WEP to demonstrate knowledge of a WEP encryption key. The IEEE 802.11 authentication mechanism also allows definition of new authentication methods.

An RSNA also supports authentication based on IEEE 802.1X, or preshared keys (PSKs). IEEE 802.1X authentication utilizes the EAP to authenticate STAs and the AS with one another. This amendment does not specify an EAP method that is mandatory to implement. See 8.4.4 for a description of the IEEE 802.1X authentication and PSK usage within an IEEE 802.11 IBSS.

In an RSNA, IEEE 802.1X Supplicants and Authenticators exchange protocol information via the IEEE 802.1X Uncontrolled Port. The IEEE 802.1X Controlled Port is blocked from passing general data traffic between two STAs until an IEEE 802.1X authentication procedure completes successfully over the IEEE 802.1X Uncontrolled Port.

### **5.9.2.2 Operations with PSK**

The following AKM operations are carried out when the PMK is a PSK:

- A STA discovers the AP's security policy through passively monitoring Beacon frames or through active probing (shown in Figure 11a). A STA associates with an AP and negotiates a security policy. The PMK is the PSK.
- The 4-Way Handshake using EAPOL-Key frames is used just as with IEEE 802.1X authentication, when an AS is present. See Figure 11c.
- The GTK and GTK sequence number are sent from the Authenticator to the Supplicant just as in the AS case. See Figure 11c and Figure 11d.

(E.g., IEEE 802.11i).



- b) If an RSNA is based on a PSK in an ESS, the STA's SME establishes an RSNA as follows:
- 1) It identifies the AP as RSNA-capable from the AP's Beacon or Probe Response frames.
  - 2) It shall invoke Open System authentication.
  - 3) It negotiates cipher suites during the association process, as described in 8.4.2 and 8.4.3.
  - 4) It establishes temporal keys by executing a key management algorithm, using the protocol defined by 8.5. It uses the PSK as the PMK.
  - 5) It protects the data link by programming the negotiated cipher suites and the established temporal key into the MAC and then invoking protection.
- c) If an RSNA is based on a PSK in an IBSS, the STA's SME executes the following sequence of procedures:
- 1) It identifies the peer as RSNA-capable from the peer's Beacon or Probe Response frames.  
  
NOTE—STAs may respond to a data MPDU from an unrecognized STA by sending a Probe Request frame to find out whether the unrecognized STA is RSNA-capable.
  - 2) It may optionally invoke Open System authentication.
  - 3) Each STA uses the procedures in 8.5, to establish temporal keys and to negotiate cipher suites. It uses a PSK as the PMK. Note that two peer STAs may follow this procedure simultaneously. See 8.4.9.
  - 4) It protects the data link by programming the negotiated cipher suites and the established temporal key and then invoking protection.

(E.g., IEEE 802.11i).

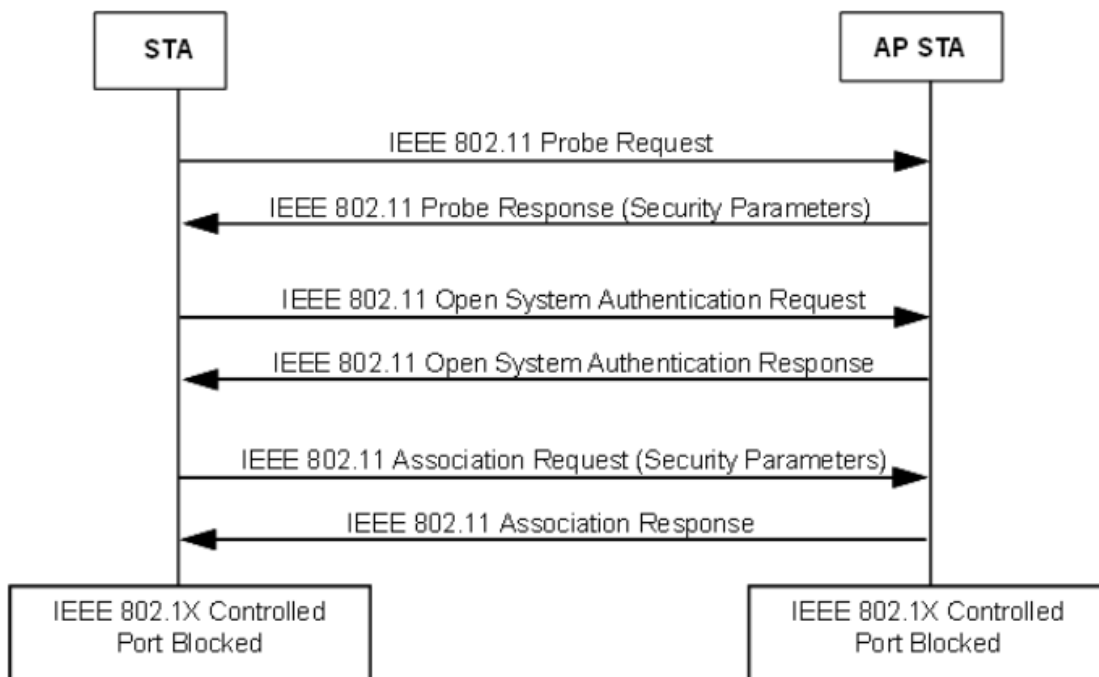

(E.g., IEEE 802.11i).

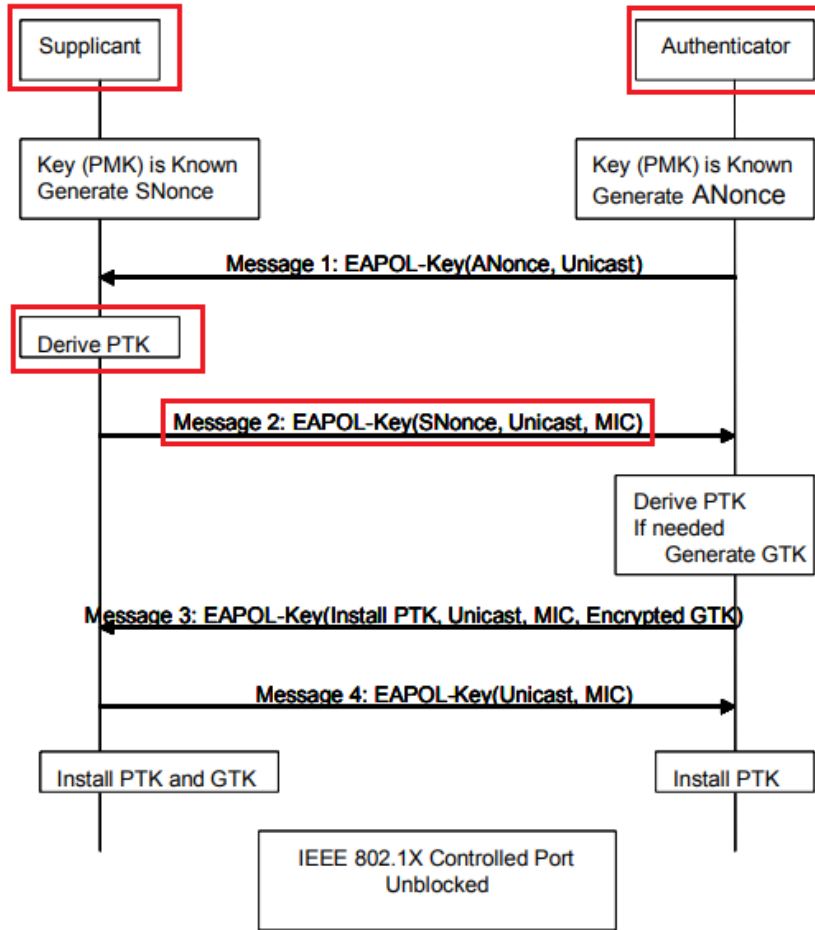

Descriptor Type – 1 octet	
Key Information – 2 octets	Key Length – 2 octets
Key Replay Counter – 8 octets	
Key Nonce – 32 octets	
EAPOL-Key IV – 16 octets	
Key RSC – 8 octets	
Reserved - 8 octets	
Key MIC – 16 octets	
Key Data Length – 2 octets	Key Data – n octets

**Figure 43u—EAPOL-Key frame**

(E.g., IEEE 802.11i).

**3.97 pairwise transient key (PTK):** A value that is derived from the pairwise master key (PMK), Authenticator address (AA), Supplicant address (SPA), Authenticator nonce (ANonce), and Supplicant nonce (SNonce) using the pseudo-random function (PRF) and that is split up into as many as five keys, i.e., temporal encryption key, two temporal message integrity code (MIC) keys, EAPOL-Key encryption key (KEK), EAPOL-Key confirmation key (KCK).

The pairwise key hierarchy utilizes PRF-384 or PRF-512 to derive session-specific keys from a PMK, as depicted in Figure 43s. The PMK shall be 256 bits. The pairwise key hierarchy takes a PMK and generates a PTK. The PTK is partitioned into KCK and KEK, and temporal keys used by the MAC to protect unicast communication between the Authenticator's and Supplicant's respective STAs. PTKs are used between a single Supplicant and a single Authenticator.

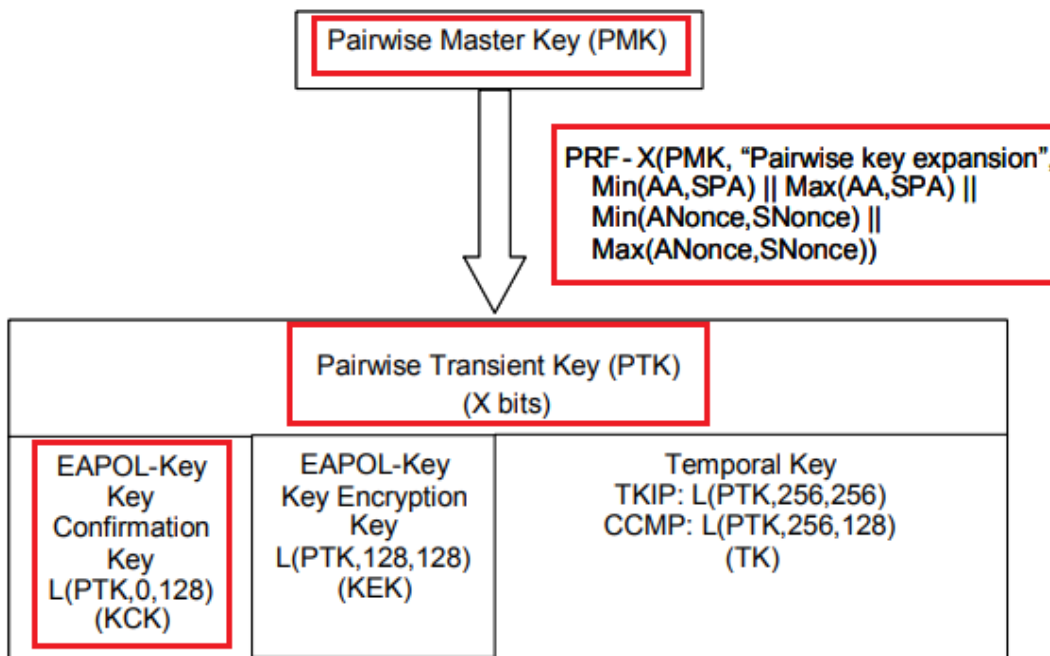

**3.117 Supplicant address (SPA):** The Supplicant's medium access control (MAC) address.

(E.g., IEEE 802.11i).

### 8.5.3.2 4-Way Handshake Message 2

Message 2 uses the following values for each of the EAPOL-Key frame fields:

Descriptor Type =  $N$  – see 8.5.2

Key Information:

Key Descriptor Version = 1 (RC4 encryption with HMAC-MD5) or 2 (NIST AES key wrap with HMAC-SHA1-128) – same as Message 1

Key Type = 1 (Pairwise) – same as Message 1

Install = 0

Key Ack = 0

Key MIC = 1

Secure = 0 – same as Message 1

Error = 0 – same as Message 1

Request = 0 – same as Message 1

Encrypted Key Data = 0

Reserved = 0 – unused by this protocol version

Key Length = 0

Key Replay Counter =  $n$  – to let the Authenticator know to which Message 1 this corresponds

Key Nonce = SNonce

EAPOL-Key IV = 0

Key RSC = 0

Key MIC = MIC(KCK, EAPOL) – MIC computed over the body of this EAPOL-Key frame with the Key MIC field first initialized to 0

Key Data Length = length in octets of included RSN information element

Key Data = included RSN information element – the sending STA's RSN information element

(*E.g.*, IEEE 802.11i).

24. Upon information and belief, the system utilized by the Accused Instrumentalities practices synchronously regenerating an authentication key (*e.g.*, temporal keys) at two network nodes (*e.g.*, the Accused Instrumentalities and an accessory device such as a Wi-Fi enabled smartphone, etc.) based upon node identifier information. As shown below, the accessory device sends its MAC address (*e.g.*, address) as well as a key value derived from the pre-shared key or pairwise master key (*e.g.*, initial authentication key) to the Accused Instrumentalities for authentication prior to connecting to the Wi-Fi network of the Accused Instrumentalities. The Accused Instrumentalities and the accessory device both regenerate temporal keys each time the devices get connected to each other. The Accused Instrumentalities and the accessory device, both

synchronously install temporal keys (i.e. a pairwise temporal key) with the help of a 4-way handshake message transfer having the node identifier information for establishing secured wireless communication.

## Modem Information

- ✓ DOCSIS 3.1 Dual Band 802.11-AC
- ✓ 32x8 channel bonding
- ✓ Compatible with future speed increases

## Highest Service Level

Cox Business Gigabit

## Front View



[Click to enlarge.](#)

After the cable modem is successfully registered on the network, a single solid white LED illuminates continuously to indicate that the cable modem is online and fully operational.

**Important:** After connecting the modem for the first time, wait 10-15 minutes before attempting to complete the WiFi setup or get online. Do not unplug the modem from power or factory reboot the modem during the initial 10-15 minute firmware download and modem registration process.

(E.g., <https://www.cox.com/business/support/technicolor-cga4131.html>).

**Figure 22: Wireless Security Settings**

The screenshot shows the 'Wireless / Security' configuration page for a Technicolor Wireless Cable Voice Gateway. The page is titled '2.4GHz Wireless Network' and displays the following settings:

Network Name	1101AC-2.4
Security Mode	WPA or WPA2 Personal
Encryption	AES/TKIP
Network Password	***** <input type="button" value="Show"/>
Key Interval	3600 Seconds

Available settings include:

**Network Name:** The Network Name is displayed here.

**Security Mode:** Options for security settings include:

- **2.4GHz:** Open, WPA2 Personal, WPA or WPA2 Personal
- **5GHz:** Open, WPA2 Personal, WPA or WPA2 Personal

The default setting is WPA or WPA2 Personal.

(E.g., <https://www.cox.com/content/dam/cox/business/documents/internet/CBIG%204131%20User%20Guide.pdf>).

**Figure 23: WPS Settings**

technicolor Wireless (WPS) Technicolor Wireless Cable Voice Gateway

Status Connection **Wireless** Security Application Administration Diagnostic

Radio Security Advanced Guest Network MAC Control **WPS** CoS Hotspot

Wi-Fi Protected Setup (WPS)

AccessPoint PIN 31752893

Connection Method Push Button (recommended) ▼

Pair with my Wi-Fi client

**2.4GHz Wireless Network**

Network Name 1101AC-2.4

Security Mode WPA-WPA2-Personal

**5GHz Wireless Network**

Network Name 1101AC-5

Security Mode WPA-WPA2-Personal

## ***Prevent Devices from Accessing Your Wireless Network***

### **MAC Address**

A MAC (Media Access Control) address is a unique hexadecimal code that identifies a device on a network. Each network-enabled device has at least one unique MAC address.

For example, if your computer is equipped with an Ethernet and a wireless network adaptor, each of these interfaces will have its own MAC address.

(E.g., <https://www.cox.com/content/dam/cox/business/documents/internet/CBIG%204131%20User%20Guide.pdf>).



#### 8.4.8 RSNA key management in an ESS

When the IEEE 802.1X authentication completes successfully, this amendment assumes that the STA's IEEE 802.1X Supplicant and the IEEE 802.1X AS will share a secret, called a PMK. The AS transfers the PMK, within the AAA key, to the AP, using a technique that is outside the scope of this amendment; the derivation of the PMK from the MSK is EAP-method-specific. With the PMK in place, the AP initiates a key confirmation handshake with the STA. The key confirmation handshake sets the IEEE 802.1X state variable portValid (as described in IEEE P802.1X-REV) to TRUE.

The key confirmation handshake is implemented by the 4-Way Handshake. The purposes of the 4-Way Handshake are as follows:

- a) Confirm the existence of the PMK at the peer.
- b) Ensure that the security association keys are fresh.
- c) Synchronize the installation of temporal keys into the MAC.
- d) Transfer the GTK from the Authenticator to the Supplicant.

(E.g., IEEE 802.11i).

These are referred to as the temporal keys because they are recomputed every time a mobile device associates to the access point. The collection of all four keys together is referred to as the pairwise transient key (PTK). For RSN/TKIP and WPA, each of these keys must be 128 bits long so that the PTK is a total of 512 bits long.

The first two temporal keys sound familiar. They are the ones used to encrypt the data and protect it from modification. The second two we have not seen before. These are used to protect the communications between the access point and mobile device during the initial handshake.<sup>[2]</sup> For the moment, just accept that these EAPOL keys are needed; we will discuss them again shortly.

<sup>[2]</sup> And for various notifications after the handshake.

Because the temporal keys are recomputed each time a mobile device connects, there has to be something that changes when the computation is done; otherwise, you'd end up with the same temporal keys every time. This is called adding liveness to the keys, ensuring that old keys no longer work. Liveness is achieved by including a couple of special values called nonces in the computation. The value of the nonce is quite arbitrary except in one respect: a nonce value is never used twice<sup>[3]</sup> with the same key. The word "nonce" can be thought of as "N ? once"?in other words, a value (N) only used once.<sup>[4]</sup> They say lightning never strikes in the same place twice (which is not true) and similarly nonces never come up with the same value twice (which should be true by design).

(E.g., <http://etutorials.org/Networking/802.11+security.+wi-fi+protected+access+and+802.11i/Part+II+The+Design+of+Wi-Fi+Security/Chapter+10.+WPA+and+RSN+Key+Hierarchy/Pairwise+Key+Hierarchy/>).

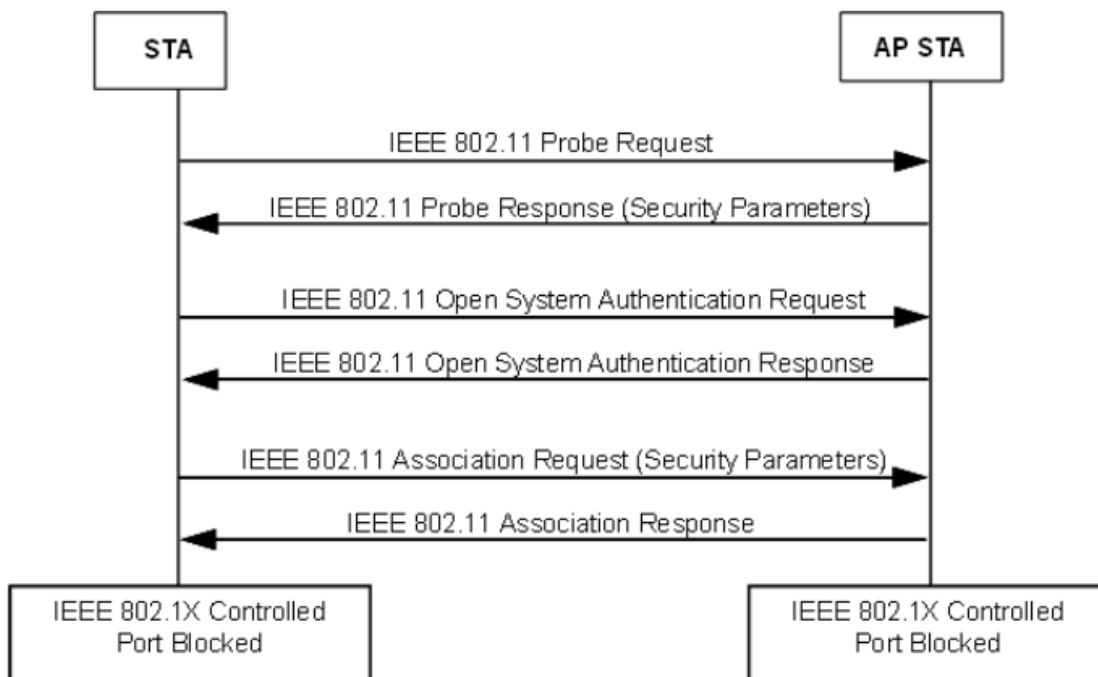

(E.g., IEEE 802.11i).

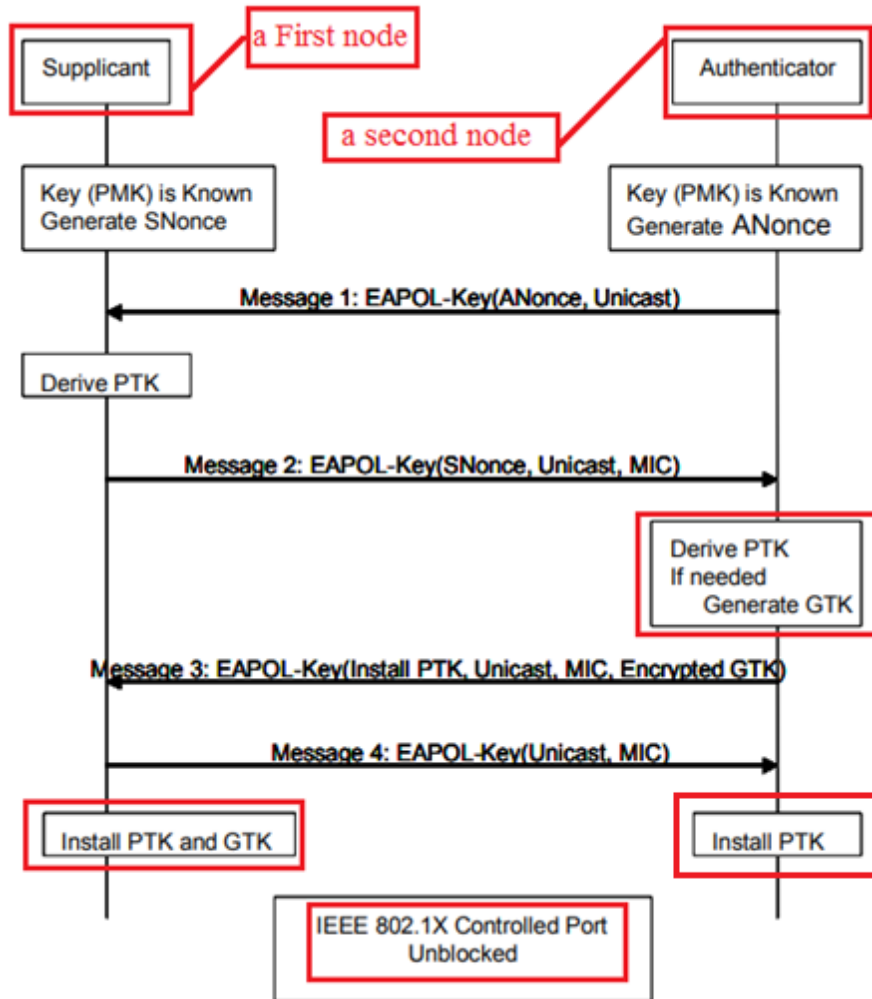

**3.97 pairwise transient key (PTK):** A value that is derived from the pairwise master key (PMK), Authenticator address (AA), Supplicant address (SPA), Authenticator nonce (ANonce), and Supplicant nonce (SNonce) using the pseudo-random function (PRF) and that is split up into as many as five keys, i.e., temporal encryption key, two temporal message integrity code (MIC) keys, EAPOL-Key encryption key (KEK), EAPOL-Key confirmation key (KCK).

(E.g., IEEE 802.11i).

The pairwise key hierarchy utilizes PRF-384 or PRF-512 to derive session-specific keys from a PMK, as depicted in Figure 43s. The PMK shall be 256 bits. The pairwise key hierarchy takes a PMK and generates a PTK. The PTK is partitioned into KCK and KEK, and temporal keys used by the MAC to protect unicast communication between the Authenticator's and Supplicant's respective STAs. PTKs are used between a single Supplicant and a single Authenticator.

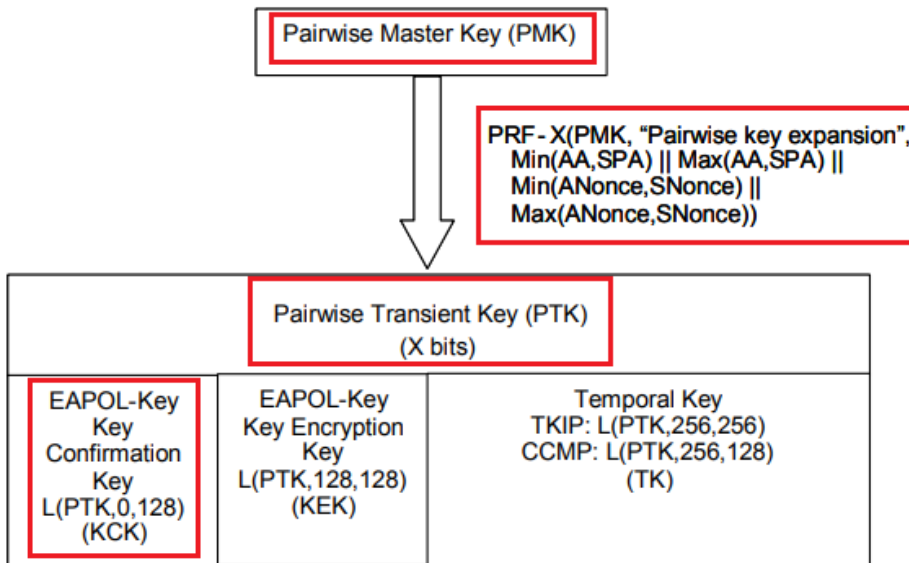

(E.g., IEEE 802.11i).

25. Defendant's customers also infringe claim 1 of the '664 patent by using or performing the claimed method using the Accused Instrumentalities as described above. Furthermore, Defendant advertises, markets, and offers for sale the Accused Instrumentalities to its customers for use in a system in a manner that, as described above, infringes claim 1 of the '664 patent. Exemplary advertising and marketing material is cited above.

26. Plaintiff has been damaged as a result of Defendant's infringing conduct. Defendant is thus liable to Plaintiff for damages in an amount that adequately compensates Plaintiff for such Defendant's infringement of the '664 patent, *i.e.*, in an amount that by law cannot be less than would constitute a reasonable royalty for the use of the patented technology, together with interest and costs as fixed by this Court under 35 U.S.C. § 284.

27. On information and belief, Defendant has had at least constructive notice of the '664 patent by operation of law and, to the extent required, marking requirements have been complied with.

28. On information and belief, Defendant will continue its infringement of one or more claims of the '664 patent unless enjoined by the Court. Defendant's infringing conduct thus causes Plaintiff irreparable harm and will continue to cause such harm without the issuance of an injunction.

#### **IV. JURY DEMAND**

Plaintiff, under Rule 38 of the Federal Rules of Civil Procedure, requests a trial by jury of any issues so triable by right.

#### **V. PRAYER FOR RELIEF**

WHEREFORE, Plaintiff respectfully requests that the Court find in its favor and against Defendant, and that the Court grant Plaintiff the following relief:

- a. Judgment that one or more claims of United States Patent No. 7,233,664 have been infringed, either literally and/or under the doctrine of equivalents, by Defendant;
- b. Judgment that Defendant account for and pay to Plaintiff all damages to and costs incurred by Plaintiff because of Defendant's infringing activities and other conduct complained of herein;
- c. That Defendant be enjoined from future infringing activities;
- d. That Plaintiff be granted pre-judgment and post-judgment interest on the damages caused by Defendant's infringing activities and other conduct complained of herein; and
- e. That Plaintiff be granted such other and further relief as the Court may deem just and proper under the circumstances.

September 23, 2024

DIRECTION IP LAW

/s/ David R. Bennett

David R. Bennett

Steven G. Kalberg

Direction IP Law

P.O. Box 14184

Chicago, IL 60614-0184

(312) 291-1667

dbennett@directionip.com

skalberg@directionip.com

*Attorneys for Plaintiff*

*Encryptawave Technologies LLC*