

1 Sean A. O'Brien, Bar No. 133154
2 sao@paynefears.com
3 Benjamin A. Nix, Bar No. 138258
4 ban@paynefears.com
5 PAYNE & FEARS LLP
6 4 Park Plaza, Suite 1100
7 Irvine, CA 92614
8 Telephone: (949) 851-1100
9 Facsimile: (949) 851-1212

10 Robert R. Brunelli (to be admitted *pro hac vice*)
11 rbrunelli@sheridanross.com
12 Scott R. Bialecki (to be admitted *pro hac vice*)
13 sbialecki@sheridanross.com
14 Tristan D. Lewis (to be admitted *pro hac vice*)
15 tlewis@sheridanross.com
16 SHERIDAN ROSS P.C.
17 1560 Broadway, Suite 1200
18 Denver, CO 80202
19 Telephone: (303) 863-9700
20 Facsimile: (303) 863-0223
21 litigation@sheridanross.com

22 *Attorneys for Plaintiff K.Mizra LLC*

23 **UNITED STATES DISTRICT COURT**
24 **CENTRAL DISTRICT OF CALIFORNIA**

25 K.MIZRA LLC,
26
27 Plaintiff,
28 v.
29 EPSON AMERICA, INC., and
30 SEIKO EPSON CORPORATION
31
32 Defendants.

Case No.: 8:25-cv-00027

**COMPLAINT FOR PATENT
INFRINGEMENT**

DEMAND FOR JURY TRIAL

1 Plaintiff K.Mizra LLC ("Plaintiff" or "K.Mizra"), for its Complaint for Patent
2 Infringement and Demand for Jury Trial against Defendants Seiko Epson Corporation
3 and Epson America, Inc. (collectively, "Defendants" or "Epson"), alleging, based on
4 its own knowledge as to itself and its own actions, and based on information and belief
5 as to all other matters, states as follows:

6 **I. INTRODUCTION**

7 **A. Sharp And Its Innovations**

8 1. Sharp Corporation ("Sharp") is a Japanese multinational company that
9 has for more than a century conceived, designed, manufactured, and sold, first in
10 Japan and then worldwide, various innovative products. Indeed, the company was
11 founded in 1912 in Tokyo and takes its name from one of its founders' first inventions,
12 the Ever-Sharp mechanical pencil. Sharp currently employs more than 50,000 people
13 worldwide and has been inventing the future in numerous existing and emerging
14 product categories for decades.

15 2. For more than sixty years now, Sharp has been heavily involved in the
16 electronics products business, developing the first Japanese-produced televisions in
17 1953. In 2000, its Mobile Communications Division created the world's first camera
18 phone. Sharp also invested heavily in its document product and solutions division,
19 earning high praise and prestigious awards from various industry publications and
20 insiders for innovations in printer, copier, and facsimile technologies it was
21 developing and introducing to the market. Indeed, many of these innovations changed
22 these product categories forever and helped to establish multifunction printers, *i.e.*,
23 all-in-one copier, printing, faxing and scanning devices ("MFPs"), as a mainstay of
24 the modern office. These products take many forms, with one such Sharp device being
25 shown below:

26
27
28



1
2
3
4
5
6
7
8
9
10
11
12
13
14
15

16 3. Sharp's MFPs were precision engineered to make device setup easier and
17 faster than previously available and to provide easy-to-use, efficient and effective
18 multi-level document production and assembly functionality to the modern and
19 typical office worker. Sharp's integrated product design and engineering approach to
20 developing these state-of-the-art MFPs resulted in providing office workers with
21 increased workflow efficiency, exceptional image quality and an industry standard
22 ease of product operation, control, management, and maintenance, helping to take
23 each customer's business to the next level of productivity and performance.

24 4. Given its culture of innovation, and recognition that its industry changing
25 concepts often were emulated by "Johnny-come-lately" competitors, Sharp took pains
26 to document and protect its various MFP-focused inventions. These took the form of,
27 among other things, filing and prosecuting to issuance many patents covering various
28 aspects of the technologies it had developed and incorporated over time into its

1 various MFP products. These patents were issued in many countries, including the
2 United States, Germany, and Japan. As is too often the case, though, these protections
3 were not self-policing in the MFP industry, with many of Sharp's competitors having
4 taken its patented technologies for themselves and incorporated them into their
5 commercial MFP offerings, without providing Sharp the economic credit deserved
6 for its many, many efforts and advancements. This case concerns just such a situation.

7 **B. K.Mizra And This Action**

8 5. K.Mizra is a patent licensing company run by experienced management.
9 The company focuses on high value, high quality patents with a global reach and owns
10 patent portfolios originating with a wide array of inventors, including portfolios
11 developed by well-known multinationals such as IBM, Panasonic and ZTE and from
12 research institutes such as National Chiao Tung University and Nederlandse
13 Organisatie voor Toegepast Natuurwetenschappelijk Onderzoek (Netherlands
14 Organization for Applied Scientific Research). By focusing on high quality patents,
15 K.Mizra provides a secondary market for inventors to recoup their research and
16 development investments and to continue their innovations. K.Mizra offers licenses
17 to its patents on reasonable terms and in this way plays a part in the development of
18 the technologies that improve our lives.

19 6. Sharp transferred its MFP-focused patents to K.Mizra, which now brings
20 this action to enforce these valid and subsisting United States patent rights. K.Mizra
21 is the owner by assignment of all rights, title, and interests in and to all the patents
22 discussed below.

23 **II. PARTIES**

24 7. Plaintiff is a limited liability company organized and existing under the
25 laws of the state of Delaware and maintains a business address at 777 Brickell
26 Avenue, #500-96031, Miami, Florida 33131.

27
28

1 8. Defendant Seiko Epson Corporation is a company organized and existing
2 under the laws of Japan having a principal place of business at 3-3-5 Owa Suwa-Shi
3 Nagano-Ken, 392-8502, Japan ("SEC").

4 9. Defendant Epson America, Inc. is a company organized and existing
5 under the laws of the state of California having a principal place of business at
6 3131 Katella Avenue, Los Alamitos, California 90720 ("EAI"). EAI may be served
7 via its registered agent, CSC–Lawyers Incorporating Service, 2710 Gateway Oaks
8 Drive, Suite 150N, Sacramento, California 95833. On information and belief, EAI is
9 a wholly owned subsidiary of SEC and with these entities being collectively referred
10 to herein as "Epson" or "Defendants" unless separately identified.

11 10. EAI is a general manager for SEC in the state of California. On
12 information and belief, EAI is headquartered in California to conduct SEC's business
13 in California and the rest of the United States. *See, e.g.*, Mot. to Transfer Venue 19,
14 ECF No. 16, Dec. 21, 2021, *American Patents LLC v. Seiko Epson Corp.*, No. 4:21-
15 cv-00718-ALM (E.D. Tex.) ("the Central District of California is home to Epson
16 America, the Epson entity responsible for marketing and sales of the accused products
17 in the United States"). On information and belief, EAI's responsibilities specifically
18 include selling SEC's products, providing a warranty service for SEC's products,
19 providing English owner manuals for SEC's products, testing SEC's products,
20 marketing SEC's products, receiving complaints about SEC's products, and acting as
21 a distributor for SEC's products in California and the rest of the United States. *See,*
22 *e.g., id.* at 2 ("So there is no doubt [Plaintiff] is aware of Epson America and its role
23 as the importer, seller, marketer, and distributor of the accused products."). Further,
24 on information and belief the relationship between EAI and SEC provides SEC with
25 the business advantages that it would enjoy if it conducted its business through its
26 own offices or paid agents in California because EAI acts as the exclusive seller of
27 SEC products in the United States, including California. *See id.* at 14 ("all U.S. sales
28 of Epson products fall within the purview of Epson America").

1 11. Defendants have acted in concert with respect to the conduct complained
2 of herein such that any action of one is attributable to all.

3 **III. JURISDICTION AND VENUE**

4 12. This is an action for patent infringement under the patent laws of the
5 United States, namely, 35 U.S.C. §§ 101 *et seq.*, 271, 281, and 284, among others.
6 This Court has original subject matter jurisdiction over this dispute pursuant to 28
7 U.S.C. §§ 1331 and 1338(a).

8 13. This Court has personal jurisdiction over EAI for at least the following
9 reasons: (1) EAI maintains its principal place of business in this District; and (2) EAI
10 resides in this District.

11 14. This Court has personal jurisdiction over SEC because SEC has regular,
12 systematic, and continuous contacts with California. On information and belief, SEC
13 either directly or through EAI, imported, manufactured, used, offered for sale, and/or
14 sold in California, and within this District, printer/copier/scanner-related products,
15 software, and systems that infringe the Asserted Patents (further defined below).
16 Further, on information and belief, EAI is a wholly owned subsidiary of SEC, and
17 acts as the exclusive licensee and distributor of SEC products. *See, e.g.*, Def.
18 Corporate Disclosure Statement, ECF No. 43, Feb. 25, 2014, *Technology Properties*
19 *Limited, LLC v. Canon, Inc., et al.*, No. 6:12-cv-00202-MHS (E.D. Tex.) ("Epson
20 America, Inc. discloses that it is 100% owned by U.S. Epson, Inc. U.S. Epson, Inc. is
21 100% owned by Seiko Epson Corporation") (emphasis original).

22 15. Alternatively, and if SEC is not subject to jurisdiction in any state court
23 of general jurisdiction, upon information and belief, SEC has intentionally and
24 purposefully availed itself of the privilege of doing business in the state of California
25 and this District by placing its products into the stream of commerce with both the
26 knowledge and intent that the products be sold in California and this District. *See,*
27 *e.g.*, Compl. ¶ 8, ECF No. 1, Apr. 10, 2023, *Seiko Epson Corp. v. Planet Green*
28 *Cartridges*, No. 2:23-cv-02692 (C.D. Cal.) ("[Epson America Inc is] the North

1 American sales, marketing, and customer service affiliate of Seiko Epson"). Plaintiff's
2 claim arises out of SEC, either directly or through EAI, importing, manufacturing,
3 using, offering for sale, or selling infringing products within California and this
4 District. Finally, it would be fair and reasonable for SEC to be subject to personal
5 jurisdiction in this Court.

6 16. Indeed, SEC has also routinely acted as a plaintiff in California,
7 voluntarily subjecting itself to personal jurisdiction in this District. *See e.g., Seiko*
8 *Epson Corp. v. Audoormatics USA, Inc.*, No. 2:20-cv-11148 (C.D. Cal.); *Seiko Epson*
9 *Corp. v. RJ International Group, Inc.*, No. 2:22-cv-01122 (C.D. Cal.); *Seiko Epson*
10 *Corp. v. Vintrick, Inc.*, No. 2:19-cv-10697 (C.D. Cal.). In addition, SEC has
11 specifically admitted that any evidence relating to its products is located in California.
12 *See, e.g.,* Mot. to Transfer Venue 16, ECF No. 16, Dec. 21, 2021, *American Patents*
13 *LLC v. Seiko Epson Corp.*, No. 4:21-cv-00718-ALM (E.D. Tex.) ("Any evidence
14 relating to the accused products is in California (and Japan).").

15 17. Alternatively, and if SEC is not subject to jurisdiction in any state court
16 of general jurisdiction, upon information and belief, SEC has purposefully availed
17 itself of the privilege of conducting business activities and causing a consequence
18 throughout the United States by advertising and regularly selling infringing products
19 to consumers through its highly interactive commercial website. These activities in
20 their aggregate subject SEC to jurisdiction of this Court pursuant to Fed. R. Civ. P.
21 4(k)(2), and exercising such jurisdiction is consistent with the United States
22 Constitution and laws.

23 18. Venue is proper in this judicial district pursuant to 28 U.S.C. § 1391(b)
24 and (c), and 28 U.S.C. § 1400(b) because Defendants have a regular and established
25 place of business in this District and Defendants have committed acts of infringement
26 in this District. In addition, venue is proper with regard to SEC as it is subject to this
27 Court's personal jurisdiction as demonstrated above. In fact, SEC has sought to
28 transfer similar actions to this District in the past. *See, e.g., Seiko Epson Corp.*, Mot.

1 to Transfer Venue 19, ECF No. 16, Dec. 21, 2021, *American Patents LLC v. Seiko*
2 *Epson Corp.*, No. 4:21-cv-00718-ALM (E.D. Tex.) (SEC arguing that "the Central
3 District of California is home to Epson America, the Epson entity responsible for
4 marketing and sales of the accused products in the United States"); Compl. ¶ 8, ECF
5 No. 1, Apr. 10, 2023, *Seiko Epson Corp. v. Planet Green Cartridges*, No. 2:23-cv-
6 02692 (C.D. Cal.) As noted above, SEC has taken advantage of being a plaintiff in
7 this District on numerous occasions.

8 **IV. FACTUAL ALLEGATIONS**

9 **A. The Asserted Patents**

10 **1. U.S. Patent No. 7,568,170**

11 19. On July 28, 2009, the United States Patent and Trademark Office
12 ("USPTO") duly and legally issued U.S. Patent No. 7,568,170 ("the '170 Patent")
13 entitled "Data Processing Setting Apparatus, Data Processing Setting Method, Data
14 Processing Setting Program, and Computer Readable Recording Medium Recording
15 the Program" to Sharp. Sharp assigned the '170 Patent to K.Mizra, and that
16 Assignment is recorded beginning at Reel/Frame No. 054223/0499 of the USPTO
17 Assignment database. A true and correct copy of the '170 Patent is attached hereto as
18 Exhibit 1, page 34, and incorporated herein in its entirety by reference.

19 20. The '170 Patent is directed to the user interface of a data setting device,
20 wherein the interface allows the user to select a desired function from a plurality of
21 information processing functions and shows an image display preview displaying the
22 chosen functionality of the plurality of possible functions. For example, in a printing
23 preference interface, a user may select from several possible functions for the printer
24 to staple and punch the print job. The interface will then display in a separate area of
25 the screen an image previewing the selected functions.

26 21. Claim 1 of the '170 Patent addresses at least some of these concepts and
27 states:

28 A data processing setting apparatus comprising:

1 display control section for displaying plural kinds of
2 function information on a setting screen image for setting
3 a data processing, each of the plural kinds of function
4 information indicating a function of the data processing
5 and being able to be identified by the function;
6 function setting [section]¹ for (i) selecting the function
7 corresponding to the function information selected, in
8 response to an input instruction, from plural pieces of
9 function information among the plural kinds of function
10 information, the plural pieces of function information
11 being displayed on the setting screen image, and (ii)
12 setting the selected function;
13 set information display processing section for displaying
14 set information in a region of the setting screen image, not
15 in a region in which the plural kinds of function
16 information are displayed by said display control section,
17 the set information corresponding to the function set by
18 said function setting section and indicating that the
19 function has already been set; and
20 resulting image display processing section for displaying
21 a resulting image in a region of the setting screen image,
22 not in the region in which the plural kinds of function
23 information are displayed by said display control section
24 or in the region in which the set information is displayed
25 by said set information display processing section, the
26

27
28 ¹As corrected by the July 28, 2009 Certificate of Correction, which reads "Column 38,
in Claim 1, line 48: the word 'means' should read --section--." (See Ex. 1, p. 96.)

1 resulting image showing a result of the data processing
2 using the function set by said function setting section;
3 wherein, when said function setting section sets a plurality
4 of functions, said resulting image display processing
5 section synthesizes a plurality of resulting images
6 corresponding to the plurality of functions, and displays
7 the synthesized image.

8 (Ex. 1, pp. 94-95, 38:42-67–39:1-8.)

9 22. Epson MFPs and related printer drivers may meet all limitations of
10 Claim 1 of the '170 Patent. However, Epson is exclusively in possession of the
11 information (*e.g.*, source code and/or encrypted signal-related information) necessary
12 to confirm Epson's infringing activity. As such, K.Mizra intends to issue discovery to
13 Epson seeking that information to confirm its suspicions of Epson's infringement. In
14 addition to the information relevant to the currently Accused Patents herein, Epson
15 must also preserve all relevant information relating to at least the following Epson
16 products, which utilize printer drivers that may, and likely do, infringe the '170 Patent:
17 WorkForce Enterprise WF-M21000, WorkForce Enterprise WF-M20590F,
18 WorkForce Enterprise WF-M20590, WorkForce Enterprise WF-C21000, WorkForce
19 Enterprise WF-C20590, WorkForce Enterprise WF-C17590, WorkForce Enterprise
20 WF-C20750, WorkForce Enterprise WF-C20600, WorkForce Enterprise AM-C400,
21 WorkForce Enterprise AM-C500, Workforce Enterprise AM-C4000, WorkForce
22 Enterprise AM-C5000, and WorkForce Enterprise AM-C6000.

23 **2. U.S. Patent No. 7,570,400**

24 23. On August 4, 2009, the USPTO duly and legally issued U.S. Patent
25 No. 7,570,400 ("the '400 Patent") entitled "Document Reading Device" to Sharp.
26 Sharp assigned the '400 Patent to K.Mizra, and that Assignment is recorded beginning
27 at Reel/Frame No. 054223/0499 of the USPTO Assignment database. A true and
28

1 correct copy of the '400 Patent is attached hereto as Exhibit 2, page 97, and
2 incorporated herein in its entirety by reference.

3 24. The '400 Patent claims inventions over automatic document feeders
4 included with printer devices and is directed to an arrangement where there is a
5 movable member on the bottom side of the document feeder that pivots perpendicular
6 to the paper transport path and covers a portion of the paper transport path. The
7 movable member allows access to the transport path to remove jammed paper. The
8 bottom side of the feeder also contains a flexible sheet to hold paper onto the copying
9 surface. This flexible sheet is anchored away from the pivot point of the movable
10 member to avoid creasing the flexible sheet over time. Claim 1 of the '400 Patent is
11 directed to at least some of these concepts and states:

12 A document reading device configured to read an image
13 of an original document placed on a document platen,
14 comprising:

15 a document tray for an original document to be stacked
16 thereon;

17 an output tray for receiving the original document that is
18 output after an image thereof is read;

19 a document transport path on which the original document
20 is transported, the original transport path leading from the
21 document tray through an image reading area to the output
22 tray;

23 a movable member that serves as part of a bottom surface
24 of the document reading device, the movable member
25 being supported pivotably around a pivot axis that is
26 perpendicular to a document transport direction on the
27 document transport path, and the movable member having
28 a free end and a pivotal end; and

1 a document holder that includes a flexible sheet, the
2 document holder being positioned so as to extend over the
3 whole length and breadth of the document platen,
4 wherein the movable member is pivotable from a position
5 to cover a portion of the document transport path to a
6 position to expose the portion toward the document platen,
7 and
8 wherein the document holder is fixed at portions other than
9 a portion that is positioned immediately below the pivot
10 axis, to the bottom surface of the document reading device.

11 (Ex. 2, p. 107, 8:4-31.)

12 25. Multiple Epson MFPs meet all limitations of at least Claim 1 of the '400
13 Patent. (*See* '400 Patent Preliminary Claim Chart, attached as Exhibit 3, page 108, and
14 incorporated herein in its entirety by reference.) For example, the Epson MFP model
15 WorkForce Enterprise WF-C17590 is a document reading device, *i.e.*, scanner,
16 configured to read images of documents. The WorkForce Enterprise WF-C17590
17 contains a flatbed scanner with the claimed document platen, where an original
18 document can be placed. The WorkForce Enterprise WF-C17590 also contains an
19 automatic document feeder ("ADF") with a tray where original documents can be
20 stacked to be scanned, as shown below:

21
22
23
24
25
26
27
28

1
2
3
4
5
6
7
8
9
10
11
12
13
14
15
16
17
18
19
20
21
22
23
24
25
26
27
28

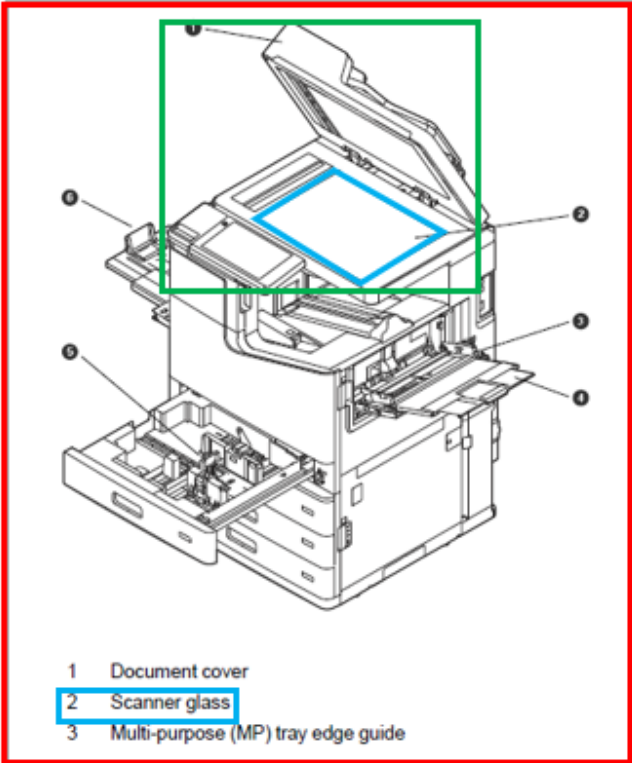
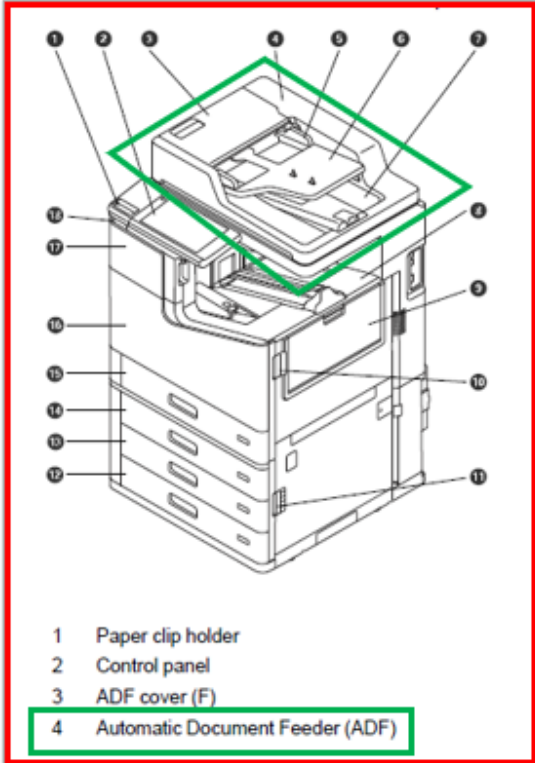

(Ex. 3, p. 112.)

26. The ADF also has an ADF bin that receives the original documents output after scanning. The WorkForce Enterprise WF-C17590 pulls documents to be scanned along a set path by a series of rollers from the ADF tray, through an area where they are read by the ADF Charge-Coupled Device ("CCD") and output to the ADF bin, all as disclosed and claimed by the '400 Patent.

27. The ADF of the WorkForce Enterprise WF-C17590 printer also contains a movable ADF bottom cover at its base, opposite the flatbed scanner platen. That cover is attached pivotably to the ADF by a hinge along its side next to the ADF bin and perpendicular to the flow of documents. The other end of the ADF bottom cover moves freely and can swing open exposing the usually hidden rollers located along the document transport path that flows over the ADF bottom cover.

28. On the bottom of the WorkForce Enterprise WF-C17590's ADF, there is a flexible white sheet of material that acts to hold documents in place on the flatbed scanner and acts as a neutral background for document reading. The document-

1 holding sheet is attached to the flat bottom surface of the ADF and the base of the
2 ADF bottom cover at several fixed points. These fixed points are not immediately
3 below the pivot axis of the ADF bottom cover, as claimed in Claim 1.

4 3. Lift the edge of the document cover as shown and use a soft, dry cloth to clean the glass strip
5 beneath the ADF.

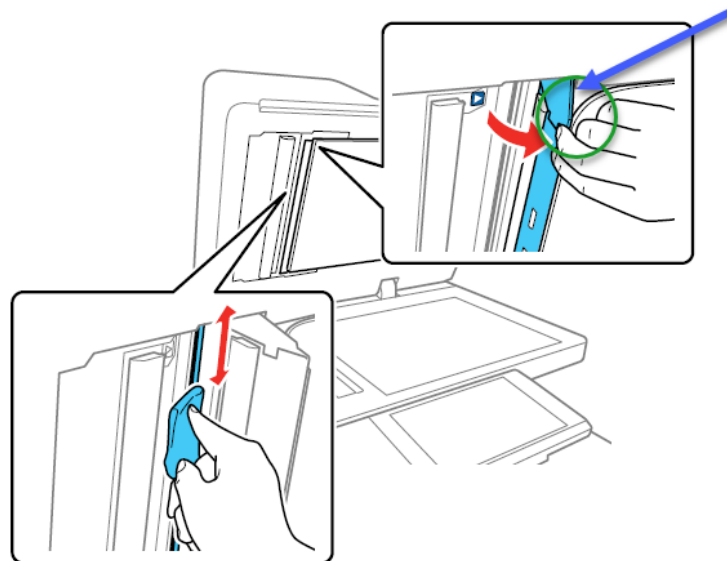

6
7
8
9
10
11
12
13
14
15 4. Close the scanner cover.

16 (Ex. 3, pp. 129-30.)

17 29. On information and belief, the WorkForce Enterprise WF-C17590 is
18 representative of other Epson products that infringe or have infringed the '400 Patent,
19 including without limitation the following model numbers: WorkForce Pro
20 WF-C879R, WorkForce Enterprise WF-M21000, WorkForce Enterprise
21 WF-M20590F, WorkForce Enterprise WF-M20590, WorkForce Enterprise
22 WF-C21000, WorkForce Enterprise WF-C20590, WorkForce Enterprise
23 WF-C20750, WorkForce Enterprise WF-C20600, WorkForce EC-C7000, WorkForce
24 Enterprise AM-C4000, WorkForce Enterprise AM-C5000, and WorkForce Enterprise
25 AM-C6000 (collectively, "the '400 Patent Accused Products").

26 30. K.Mizra provided Epson with notice of its infringement of the '400
27 Patent by letter dated at least as early as March 30, 2021.

28

1 31. On August 15, 2022, another then-accused infringer and current licensee
2 of K.Mizra ("Petitioner") filed an *Inter Partes* Review ("IPR") Petition with the U.S.
3 Patent Trial and Appeal Board ("PTAB"), alleging that the following references - (1)
4 JP 2002-278174; (2) 2004-254202; and (3) JP 2003-261242 (collectively "Prior Art")
5 - allegedly invalidated the '400 Patent under 35 U.S.C. §§ 102(a) and (b), and 103(a).
6 On March 2, 2023, the PTAB held that the Petitioner had failed to demonstrate a
7 reasonable likelihood that it would prevail as to at least one claim of the '400 Patent
8 and as such, it denied institution of the IPR.

9 **3. U.S. Patent No. 9,769,342**

10 32. On September 19, 2017, the USPTO duly and legally issued U.S. Patent
11 No. 9,769,342 ("the '342 Patent") entitled "Electric Apparatus" to Sharp. Sharp
12 assigned the '342 Patent to K.Mizra and that Assignment is recorded beginning at
13 Reel/Frame No. 054223/0499 of the USPTO Assignment database. A true and correct
14 copy of the '342 Patent is attached hereto as Exhibit 4, page 131, and incorporated
15 herein in its entirety by reference.

16 33. The '342 Patent is directed to an electric apparatus that has a control
17 panel user interface that can exist in both active and power save states. The '342 Patent
18 discloses a device that, *inter alia*, "wakes" the electrical device from a power save
19 state if the device is in hibernation or sleep mode or initiates some user function if the
20 device is already in its operational state.

21 34. Claim 1 of the '342 Patent is directed to at least some of these concepts
22 and states:

23 An electric equipment including a reception unit
24 configured to receive an instruction relating to functions
25 of the electric equipment by an operation of a user and
26 having operation states of a power conserving state in
27 which power required for performing the functions thereof
28

1 is limited and a normal state in which the power is not
2 limited, the electric equipment comprising:
3 a signal output unit configured to output signals of
4 different levels depending on the operation state when the
5 reception unit receives the instruction from the user; and
6 a control signal unit configured to selectively output a
7 return signal relating to a return to the normal state or an
8 execution signal relating to an execution of a function
9 corresponding to the instruction received by the reception
10 unit, based on the signal output from the signal output unit.

11 (Ex. 4, p. 141, 8:29-45.)

12 35. Multiple Epson MFPs meet all limitations of at least Claim 1 of the '342
13 Patent. (See '342 Patent Preliminary Claim Chart, attached as Exhibit 5, page 142, and
14 incorporated herein in its entirety by reference.) For example, the Epson MFP model
15 WorkForce Pro WF-4720 is an electronic device having a control panel capable of
16 receiving instructions related to functions of the MFP and has both power
17 conservation and normal power operating states. The control panel has a plurality of
18 physical buttons through which it may receive instructions:

19
20
21
22
23
24
25
26
27
28

1
2
3
4
5
6
7
8
9
10
11
12
13
14
15
16
17
18
19
20
21
22
23
24
25
26
27
28

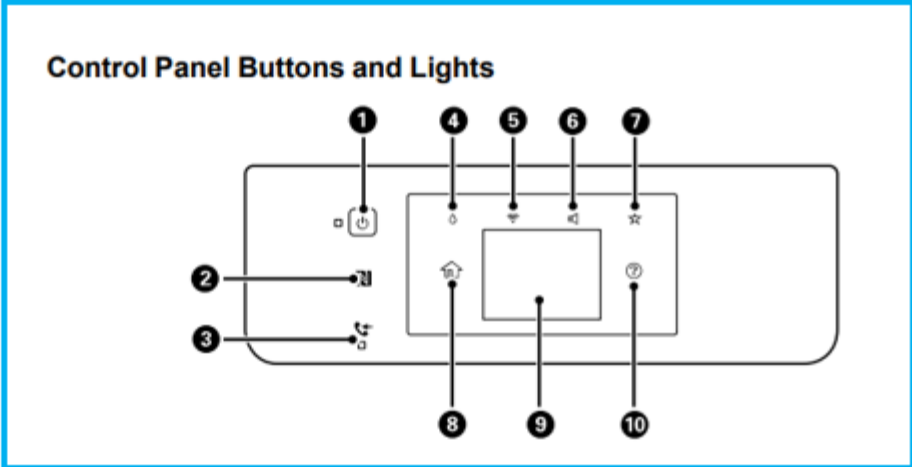

Control Panel Buttons and Lights

- 1 power button and light
- 2 NFC (Near Field Communication) tag
- 3 received fax light
- 4 supply status button
- 5 network status button
- 6 sound button
- 7 preset button
- 8 home button
- 9 LCD screen
- 10 help button

(Ex. 5, pp. 144-45.)

1 36. When the unit is in a low power state – such as sleep or hibernate –
 2 pressing the LCD screen returns the unit to the normal operating power state.
 3 However, when the unit is in the normal operating state, pressing the LCD screen has
 4 various function execution purposes, such as entering characters or viewing or
 5 changing current network settings:





6 **Status Icon Information**

7 Your product displays status icons on the LCD screen for certain product status conditions. Press the
 8  icon to view or change the current network settings.

9 **Entering Characters on the LCD Screen**

10 Follow these guidelines to enter characters for passwords and other settings.



- 11 • To move the cursor, select the left or right arrows.
- 12 • To change the case of letters, select .
- 13 • To delete the previous character, select .
- 14 • To enter numbers or symbols, select .
- 15 • To enter a space, select .

16 Parent topic: [Using the Control Panel](#)

17 **Note:** If the screen is dark, press the screen to wake the product from sleep mode.

18 (Ex. 5, pp. 150-51.)

19 37. On information and belief, the WorkForce Pro WF-4720 is
 20 representative of other Epson products that infringe or have infringed the '342 Patent,
 21 including without limitation the following model numbers: WorkForce WF-7720,
 22 WorkForce WF-7710, WorkForce WF-7620, WorkForce WF-7610, WorkForce
 23 WF-7210, WorkForce WF-7110, WorkForce WF-3640, WorkForce WF-3620,
 24 WorkForce WF-2850, WorkForce WF-2830, WorkForce Pro WF-M5799,
 25 WorkForce Pro WF-M5694, WorkForce Pro WF-M5299, WorkForce Pro WF-
 26 M5194, WorkForce Pro WF-C879R, WorkForce Pro WF-C878R, WorkForce Pro
 27 WF-C8690, WorkForce Pro WF-C8190, WorkForce Pro WF-C579R, WorkForce Pro
 28 WF-C5790, WorkForce Pro WF-C5710, WorkForce Pro WF-C529R, WorkForce Pro

1 WF-C5290, WorkForce Pro WF-C5210, WorkForce Pro WF-8590, WorkForce Pro
2 WF-8090, WorkForce Pro WF-7840, WorkForce Pro WF-7820, WorkForce Pro
3 WF-7310, WorkForce Pro WF-6590, WorkForce Pro WF-6530, WorkForce Pro
4 WF-6090, WorkForce Pro WF-5690, WorkForce Pro WF-5620, WorkForce Pro
5 WF-5110, WorkForce Pro WF-5190, WorkForce Pro WF-4834, WorkForce Pro
6 WF-4830, WorkForce Pro WF-4820, WorkForce Pro WF-4740, WorkForce Pro
7 WF-4734, WorkForce Pro WF-4730, WorkForce Pro WF-3730, WorkForce Pro WF-
8 4640, WorkForce Pro WF-4630, WorkForce Pro WF-3820, WorkForce Pro WF-
9 3720, WorkForce Pro WF-2630, WorkForce Pro WF-R8590, WorkForce Pro WF-
10 R5690, WorkForce Pro WF-R5190, WorkForce Pro WF-R4640, WorkForce Pro EC-
11 4040, WorkForce Pro EC-4030, WorkForce Pro EC-4020, WorkForce Pro WP-4530,
12 WorkForce Pro WP-4540, WorkForce Enterprise WF-M21000, WorkForce
13 Enterprise WF-M20590F, WorkForce Enterprise WF-M20590, WorkForce
14 Enterprise WF-C21000, WorkForce Enterprise WF-C20590, WorkForce Enterprise
15 WF-C17590, WorkForce Enterprise WF-C20750, WorkForce Enterprise
16 WF-C20600, WorkForce EC-C7000, WorkForce EC-C110, EcoTank Pro ET-5880,
17 EcoTank Pro ET-5850, EcoTank Pro ET-5800, EcoTank Pro ET-5170, EcoTank Pro
18 ET-5150, EcoTank Pro ET-5180, EcoTank Pro ET-16650, EcoTank Pro ET-16600,
19 EcoTank Pro ET-16500, WorkForce Pro WF-3733, WorkForce Pro WF-3730,
20 SureColor P900, SureColor P800, SureColor P700, SureColor P600, SureColor P400,
21 Expression Premium XP-7100, Expression Premium XP-6100, Expression Premium
22 XP-6000, Expression Premium XP-830, Expression Premium XP-820, Expression
23 Premium XP-640, Expression Premium XP-630, Expression Premium XP-620,
24 Expression Premium XP-520, Expression Photo XP-970, Expression Photo XP-960,
25 Expression Photo XP-950, Expression Photo XP-860, Expression Photo XP-850,
26 Expression Photo XP-8600, Expression Photo XP-8500 and Expression Photo HD
27 XP-15000 (collectively, "the '342 Patent Accused Products").

28

1 38. K.Mizra provided Epson with notice of its infringement of the '342
2 Patent by email dated July 2, 2021.

3 **4. U.S. Patent No. 10,018,938**

4 39. On July 10, 2018, the USPTO duly and legally issued U.S. Patent
5 No. 10,018,938 ("the '938 Patent"), entitled "Network System Comprising Customer
6 Replaceable Unit" to Sharp. Sharp assigned the '938 Patent to K.Mizra, and that
7 Assignment is recorded beginning at Reel/Frame No. 054223/0499 of the USPTO
8 Assignment database. A true and correct copy of the '938 Patent is attached hereto as
9 Exhibit 6, page 152, and incorporated herein in its entirety by reference.

10 40. The '938 Patent is directed to a server connected to a networked
11 multifunction printer having a consumable replaceable unit, such as a printer
12 cartridge. When the server obtains operation information from the printer, it can
13 determine the remaining level of toner in the printer and can automatically send toner
14 reorder information when the remaining toner reaches a set threshold.

15 41. Claim 3 of the '938 Patent is directed to at least some of these concepts
16 and states:

17 A system comprising:

18 an accumulation portion configured to accumulate an
19 operation performance for calculating an amount of
20 remaining toner held in a toner supply container of a
21 developing device attached to an image forming
22 apparatus;

23 a calculation portion configured to calculate the amount of
24 remaining toner held in the toner supply container based
25 on the operation performance accumulated by the
26 accumulation portion;

27 a determination portion configured to determine whether
28 the amount of remaining toner reaches a threshold; and

1 a sending portion configured to send order information
2 when it is determined that the amount of remaining toner
3 reaches the threshold.

4 (Ex. 6, p. 165, 12:28-41.)

5 42. Epson's systems comprising compatible Epson MFPs and related
6 software to provide Epson's ReadyInk service meet all limitations of Claim 3 of the
7 '938 Patent. (See '938 Patent Preliminary Claim Chart, attached as Exhibit 7, page
8 166, and incorporated herein in its entirety by reference.) For example, Epson's
9 ReadyInk service allows Epson to monitor its customers' supplies of ink² in their
10 Epson MFPs and automatically initiate replenishment orders, as shown below:

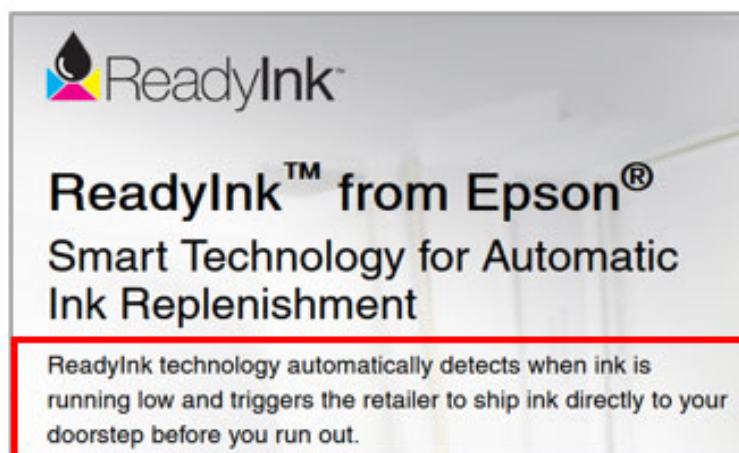

11
12
13
14
15
16
17
18
19 (Ex. 7, p. 167.)

20 43. To enable ReadyInk, Epson collects information from Epson MFPs
21 about device usage and supplies and exchanges such information over a network with
22 Epson:

23
24
25
26

27 ²To the extent "toner" is not construed to encompass ink, Epson infringes Claim 3 of
28 the '938 Patent under the doctrine of equivalents as explained in the '938 Patent
Preliminary Claim Chart. (Ex. 7, p. 173.)

1
2
3
4
5
6
7
8
9
10
11
12
13
14
15
16
17
18
19
20
21
22
23
24
25
26
27
28

HOME ▶ **Epson ReadyInk Terms and Conditions**

1. Collection and Sharing of Information from Your Printer

The Software will detect the ink volume of the Epson cartridge that is inserted into your Epson printer, among other information about use of your Epson printer such as print quantities, and will send that information to Epson, through your internet connection. Epson's proprietary measurement system measures the ink level in your printer and will signal your Retailer to re-order ink when your ink reaches a predetermined threshold established by the Retailer (or you, if your Retailer allows you to set the threshold level). You are fully responsible for obtaining and maintaining your internet connection in order for Epson to continue collecting this information.

Epson will send ink usage information collected by the Software to the Retailer you authorized to provide you with ink replenishment services. **Upon receipt of such data, the Retailer will be solely responsible for providing the replacement ink cartridge(s) for your printer pursuant to your service agreement with Retailer.** In order for the third party ink replenishment service to work, Epson will need your printer serial number, confirmation from the Retailer regarding your enrollment, information regarding your operating system and browser. Any subsequent use of this information by Retailer would be subject to the terms of its privacy policy and/or service agreement with you, if any.

The kind of information that will be automatically collected and transmitted to Epson through the internet after your activation of the Software and enrollment in Epson's ink replenishment service includes data such as your country and region, print quantities, consumption/capacity of ink, serial numbers and other Epson product information, and/or data regarding machine performance. This information will be used, and Epson may contact you regarding, service or technical issues related to your Epson product and/or any of the services set forth herein, and analysis for research and development functions utilized by Epson.

(Ex. 7, pp. 173-74.)

44. Each ReadyInk-compatible Epson MFP is an image forming device that, using ink, executes print jobs through an image forming apparatus and has a controller board that manages internal operations. Recording ink usage through the device's sensor and control, the Epson MFP collects and reports up-to-date information to Epson as the information accumulates. Epson receives data about Epson MFP's operation and calculates the amount of remaining ink supply. Epson is then able to determine when the amount of remaining ink reaches a threshold at which resupply will become necessary:

What does the Epson ReadyInk Agent do?

- It monitors how much ink is in the product's ink cartridges. When an ink cartridge reaches a low threshold, the software sends a message to Epson and a replacement cartridge is sent to you.

Disclaimers:

- Epson's proprietary measurement system measures the ink level in your printer and will signal Best Buy to re-order when 26-29% of ink remains for a given color
- Due to varying printing habits of each consumer and potential for variation in ink level measurements, you may run out of ink before the new ink shipment arrives or you may not need the new ink cartridges for a period of time when they do arrive
- For accurate ink level reporting, your printer must be connected to your PC or Mac and to the Internet

(Ex. 7, p. 178.)

45. When a device's supply level reaches that threshold, it triggers the ReadyInk Agent to submit a replenishment order to Epson. The technology necessary for Epson's ReadyInk service to occur – the accumulation and calculation of usage data, and the server's ability to initiate the proper workflow in response to this data – is disclosed in and claimed by at least Claim 3 of the '938 Patent.

46. K.Mizra provided Epson with notice of its infringement of the '938 Patent by email dated July 2, 2021.

47. The claims of the '938 Patent are not directed to an abstract idea. Rather, the '938 Patent presents a technical solution to a hardware problem. The '938 Patent is directed to previously existing problems with toner cartridges used in MFPs. The hardware environment relevant to the '938 Patent includes several physical components, as illustrated in Figure 5 from the '938 Patent:

FIG. 5 PRIOR ART

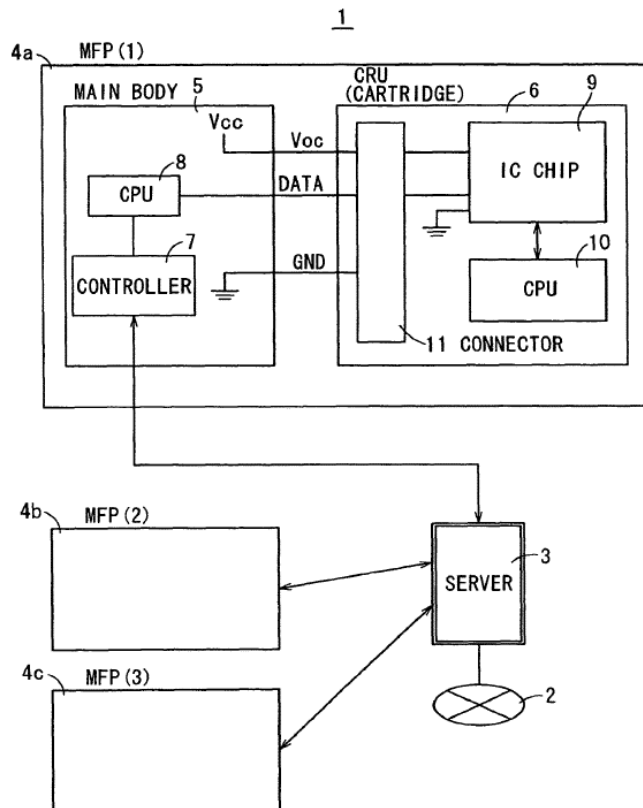

(Ex. 6, p. 159.) These include one or more MFPs having one or more toner cartridges, identified as "CRUs" (customer replaceable units). The CRUs are electronic devices that include CPUs and IC chips that are in communication with the main body of an MFP, which in turn is connected to a server. The logic within the CRU is stored on a CRU memory, referred to as a "CRUM." (Ex. 6, p. 160, 1:29-32.)

48. The '938 Patent is directed towards improvements in the performance and security of the system depicted in Figure 5. In particular, the '938 Patent recognizes the limitations of prior art approaches for "stor[ing] information on ordering into a CRUM in advance and, when a CRU reaches the limits of use through operation, provid[ing] the order information" to a user, as well as "stor[ing] a software code upgrade into a CRUM in advance so that the operator can update a software code without the need for calling a field engineer or the like." (Ex. 6, p. 160, 2:19-32.) Letting the prior art CRUM store the information created a security risk that

1 counterfeit products could be manufactured by analyzing and reproducing the
2 information stored in the prior art CRUM. (Ex. 6, p. 160, 2:34-41.) The '938 Patent
3 also recognized that memory storage limits on local CRUMs may create difficulties
4 in storing large amounts of information. (Ex. 6, p. 160, 2:41-45.)

5 49. The solution to these problems, as described and claimed by the '938
6 Patent, involves migrating the functions of the CRUM to a remote server, thereby
7 enhancing the operational efficiency and security of the network. As the '938 Patent
8 explains:

9 An object of the invention is to provide a network system
10 comprising a customer replaceable unit having an
11 excellent security function for operation information
12 which system can realize improvement of the use
13 efficiency of operation information for making a customer
14 replaceable unit operate and reduction in costs.

15 (Ex. 6, p. 160, 2:49-54.) The '938 Patent goes on to explain how the server performs
16 the function of calculating when a CRU should be replaced. For example, the
17 specification states:

18 In the server 22, the amount of remaining toner held in the
19 toner supply container is calculated from the accumulated
20 operation performance, namely, the number of rotations of
21 the toner supply roller, and it is determined whether the
22 operation performance has reached the first and second
23 threshold values or not.

24 (Ex. 6, p. 163, 8:30-36.) The '938 Patent's specification also highlights how this
25 improves the security of the system and the operation of the CRUM:

26 According to the invention, in response to the detection
27 result of the end of communication between the main-
28 body communicating portion and the unit communicating

1 portion 45 by the communication end detecting portion,
2 that is, when an operation of the apparatus main body and
3 the customer replaceable unit based on information
4 communication ends, the operation information of the
5 customer replaceable unit stored in the main-body storing
6 portion is erased by the information erasing means.
7 Consequently, the operation information necessary for the
8 operation of the customer replaceable unit does not remain
9 in either the apparatus main body or the customer
10 replaceable unit, but remains only in the server. Therefore,
11 it is possible to prevent information leakage, and exhibit a
12 high security function.

13 (Ex. 6, p. 161, 3:43-56.) In other words, because operational information is
14 maintained only in a remote server, the risk of improperly accessing and using the
15 information previously housed on a remote CRUM, *e.g.*, to manufacture counterfeit
16 products, is minimized.

17 50. In sum, the '938 Patent describes a technical solution (calculation and
18 storage of information at a server rather than a local device) to a hardware problem
19 (securely and efficiently maintaining appropriate toner levels in an MFP).
20 Accordingly, the '938 Patent is not directed to an abstract idea.

21 51. The claims of the '938 Patent also contain an inventive concept and thus
22 the claimed invention is not well-known, routine, or conventional. The claims of the
23 '938 Patent do not recite generic components, but rather non-generic features such as
24 an image forming apparatus containing a CRU, neither of which are components of a
25 generic computer. The claims of the '938 Patent are tied to specific machines – MFPs
26 containing CRUs – and are thus not properly considered generic.

27 52. Indeed, the USPTO acknowledged the eligibility of the claimed
28 invention of the '938 Patent. During prosecution of U.S. Patent Application

1 No. 11/506,082 ("the '082 Application"), the parent application of the '938 Patent, the
2 Examiner determined that claims including the main body, CRU, server, and network
3 were ineligible under 35 U.S.C. § 101 ("Section 101"). The file history of the '082
4 Application is attached and incorporated herein in its entirety as Exhibit 8, page 182.
5 The Examiner initially asserted that the invention was "directed to an abstract idea
6 including a method of organizing human activities using a generic computer without
7 reciting significantly more than the abstract idea." (Ex. 8, p. 234.) In response, the
8 Applicant explained why the Examiner's conclusion was incorrect.

9 53. First, the Applicant stated that the claimed invention includes "a server,
10 an imaging forming apparatus, and a customer replaceable unit (CRU)," and thus is
11 "unequivocally not a method of organizing human activities." (Ex. 8, p. 234.) The
12 Applicant also refuted the Examiner's assertion that the invention was mere "data
13 gathering," explaining that this improperly described the invention "at a high level of
14 abstraction while ignoring [claimed] limitation[s]." (Ex. 8, p. 234.) Rather, the
15 Applicant explained that the "recited network system, method, and apparatus include
16 an image forming apparatus containing a customer replaceable unit (CRU), neither of
17 which are components of a generic computer." (Ex. 8, p. 234.) The Applicant then
18 referenced the specification's description of "the unique advantages and benefits
19 achieved by Applicant's claimed invention." (Ex. 8, pp. 234-35.) In response, the
20 Examiner deemed the Applicant's arguments "persuasive" and withdrew the rejection
21 under Section 101. (Ex. 8, p. 222.)³

22 54. Although the claims of the '938 Patent are different from the claims at
23 issue in the parent application, they nonetheless recite a "server" and an "image
24 forming apparatus" as in the '082 Application, as well as the critical CRU. The
25 specifications are also the same. Thus, the Applicant's arguments from the '082
26

27
28 ³The Examiner maintained additional grounds of rejection and the '082 Application
was abandoned.

1 Application, and the Examiner's conclusion as to Section 101 eligibility, apply with
2 equal force to the '938 Patent.

3 **V. FIRST CLAIM FOR RELIEF**

4 **(Count I – Patent Infringement of U.S. Patent No. 7,570,400)**

5 55. Plaintiff repeats and re-alleges the allegations above in Paragraphs
6 23 – 31 as if fully set forth herein.

7 56. The '400 Patent includes four claims. Epson directly infringes one or
8 more of these claims without the authority of Plaintiff by importing, manufacturing,
9 using, offering for sale, and selling products and systems.

10 57. More specifically and without limitation, Epson has been and is directly
11 infringing, either literally or under the doctrine of equivalents, at least Claim 1 of the
12 '400 Patent by importing, manufacturing, using, offering for sale, and/or selling the
13 '400 Patent Accused Products, including but not limited to, the WorkForce Enterprise
14 WF-C17590, as shown in the '400 Patent Preliminary Claim Chart (Ex. 3, p. 108).

15 58. On information and belief, Epson is also liable for inducing infringement
16 of the '400 Patent under 35 U.S.C. § 271(b) by having knowledge of the '400 Patent
17 and knowingly causing or intending to cause, and continuing to knowingly cause or
18 intend to cause, direct infringement of the '400 Patent, with specific intent, by its
19 customers. Specifically, Epson induces infringement of the '400 Patent by promotion
20 and/or sales of the '400 Patent Accused Products. Upon information and belief,
21 Epson's customers of the '400 Patent Accused Products also directly infringe the '400
22 Patent by using the '400 Patent Accused Products as instructed by Epson. (*See, e.g.,*
23 *Ex. 3 for examples from Epson's manuals and/or advertising.*)

24 59. As alleged above, Epson had prior knowledge of the '400 Patent at least
25 as early as March of 2021 and knew, should have known, or was willfully blind to the
26 fact of Epson's infringement of the '400 Patent prior to the filing of this Complaint.
27 Despite knowing that its actions constitute induced infringement of the '400 Patent
28 and/or despite knowing that there was a high likelihood that its actions constitute

1 induced infringement of the '400 Patent, Epson nevertheless continues its infringing
2 actions, and continues to make, use, sell and/or offer for sale the '400 Patent Accused
3 Products.

4 60. Epson is thus liable for infringement of the '400 Patent pursuant to 35
5 U.S.C. § 271.

6 61. Epson's infringement of the '400 Patent has been and continues to be
7 willful.

8 62. Epson is liable to Plaintiff in an amount that adequately compensates it
9 for its infringement in an amount that is not less than a reasonable royalty, together
10 with interest and costs as fixed by this Court under 35 U.S.C. § 284.

11 **VI. SECOND CLAIM FOR RELIEF**

12 **(Count II – Patent Infringement of U.S. Patent No. 9,769,342)**

13 63. Plaintiff repeats and re-alleges the allegations above in Paragraphs
14 32 – 38 as if fully set forth herein.

15 64. The '342 Patent includes three claims. Epson directly infringes one or
16 more of these claims without the authority of Plaintiff by importing, manufacturing,
17 using, offering for sale, and selling products and systems.

18 65. More specifically and without limitation, Epson has been and is directly
19 infringing, either literally or under the doctrine of equivalents, at least Claim 1 of the
20 '342 Patent by importing, manufacturing, using, offering for sale, and/or selling the
21 '342 Patent Accused Products, including but not limited to, the WorkForce Pro WF-
22 4720 as shown in the '342 Patent Preliminary Claim Chart (Ex. 5, p. 142).

23 66. On information and belief, Epson is also liable for inducing infringement
24 of the '342 Patent under 35 U.S.C. § 271(b) by having knowledge of the '342 Patent
25 and knowingly causing or intending to cause, and continuing to knowingly cause or
26 intend to cause, direct infringement of the '342 Patent, with specific intent, by its
27 customers. Specifically, Epson induces infringement of the '342 Patent by promotion
28 and/or sales of the '342 Patent Accused Products. Upon information and belief,

1 Epson's customers of the '342 Patent Accused Products also directly infringe the '342
2 Patent by using the '342 Patent Accused Products as instructed by Epson. (*See, e.g.,*
3 Ex. 5 for examples from Epson's manuals and/or advertising.)

4 67. As alleged above, Epson had prior knowledge of the '342 Patent at least
5 as early as July of 2021 and knew, should have known, or was willfully blind to the
6 fact of Epson's infringement of the '342 Patent prior to the filing of this Complaint.
7 Despite knowing that its actions constitute induced infringement of the '342 Patent
8 and/or despite knowing that there was a high likelihood that its actions constitute
9 induced infringement of the '342 Patent, Epson nevertheless continues its infringing
10 actions, and continues to make, use, sell and/or offer for sale the '342 Patent Accused
11 Products.

12 68. Epson is thus liable for infringement of the '342 Patent pursuant to 35
13 U.S.C. § 271.

14 69. Epson's infringement of the '342 Patent has been and continues to be
15 willful.

16 70. Epson is liable to Plaintiff in an amount that adequately compensates it
17 for their infringement in an amount that is not less than a reasonable royalty, together
18 with interest and costs as fixed by this Court under 35 U.S.C. § 284.

19 **VII. THIRD CLAIM FOR RELIEF**

20 **(Count III – Patent Infringement of U.S. Patent No. 10,018,938)**

21 71. Plaintiff repeats and re-alleges the allegations above in Paragraphs
22 39 – 54 as if fully set forth herein.

23 72. The '938 Patent includes four claims. Epson directly infringes one or
24 more of these claims without the authority of Plaintiff by importing, manufacturing,
25 using, offering for sale, and selling products and systems.

26 73. More specifically and without limitation, Epson has been and is directly
27 infringing, either literally or under the doctrine of equivalents, at least Claim 3 of the
28 '938 Patent by importing, manufacturing, using, offering for sale, and/or selling

1 infringing systems, including but not limited to, those implementing its ReadyInk
2 service, as shown in the '938 Patent Preliminary Claim Chart (Ex. 7, p. 166)
3 (collectively, "the '938 Patent Accused Products".)

4 74. On information and belief, Epson is also liable for inducing infringement
5 of the '938 Patent under 35 U.S.C. § 271(b) by having knowledge of the '938 Patent
6 and knowingly causing or intending to cause, and continuing to knowingly cause or
7 intend to cause, direct infringement of the '938 Patent, with specific intent, by its
8 customers. Specifically, Epson induces infringement of the '938 Patent by promotion
9 and/or sales of the '938 Patent Accused Products. Upon information and belief,
10 Epson's customers of the '938 Patent Accused Products also directly infringe the '938
11 Patent by using the '938 Patent Accused Products as instructed by Epson. (*See, e.g.,*
12 Ex. 7 for examples from Epson's manuals and/or advertising.)

13 75. As alleged above, Epson had prior knowledge of the '938 Patent at least
14 as early as July of 2021 and knew, should have known, or was willfully blind to the
15 fact of Epson's infringement of the '938 Patent prior to the filing of this Complaint.
16 Despite knowing that its actions constitute induced infringement of the '938 Patent
17 and/or despite knowing that there was a high likelihood that its actions constitute
18 induced infringement of the '938 Patent, Epson nevertheless continues its infringing
19 actions, and continues to make, use, sell and/or offer for sale the '938 Patent Accused
20 Products.

21 76. Epson is thus liable for infringement of the '938 Patent pursuant to 35
22 U.S.C. § 271.

23 77. Epson's infringement of the '938 Patent has been and continues to be
24 willful.

25 78. Epson is liable to Plaintiff in an amount that adequately compensates it
26 for Epson's infringement in an amount that is not less than a reasonable royalty,
27 together with interest and costs as fixed by this Court under 35 U.S.C. § 284.

28

1
2
3
4
5
6
7
8
9
10
11
12
13
14
15
16
17
18
19
20
21
22
23
24
25
26
27
28

VIII. PRAYER FOR RELIEF

K.Mizra requests that the Court find in its favor and against Defendants, and that the Court grant K.Mizra the following relief:

A. Judgment that one or more claims of the '400, '342 and '938 Patents ("Asserted Patents") have been infringed, either literally and/or under the doctrine of equivalents, by Defendants;

B. Declaring that the Asserted Patents are valid and enforceable;

C. Awarding damages in an amount to be proven at trial, but in no event less than a reasonable royalty, for Defendants' infringement, including entry of a judgment that Defendants account for and pay to K.Mizra all damages to, including a reasonable royalty, and costs incurred by K.Mizra because of Defendants' infringing activities and other conduct complained of herein, including an award of all increased damages to which K.Mizra is entitled under 35 U.S.C. § 284 since at least as early as when Defendants received actual notice of their infringement;

D. Declaring this an exceptional case for at least its willful infringement and awarding K.Mizra its attorneys' fees and costs in accordance with 35 U.S.C. § 285;

E. Pre-judgment and post-judgment interest on the damages caused to K.Mizra by reason of Defendants' infringing activities and other conduct complained of herein; and

F. Such other and further relief as the Court may deem just and proper under the circumstances.

IX. DEMAND FOR JURY TRIAL

K.Mizra requests a trial by jury pursuant to Fed. R. Civ. P. 38.

1 Dated: January 7, 2025

Respectfully submitted,

2 By: /s/ Sean A. O'Brien

3 Sean A. O'Brien, Bar No. 133154

4 sao@paynefears.com

Benjamin A. Nix, Bar No. 138258

5 ban@paynefears.com

6 PAYNE & FEARS LLP

4 Park Plaza, Suite 1100

7 Irvine, CA 92614

8 Telephone: (949) 851-1100

9 Facsimile: (949) 851-1212

10 Robert R. Brunelli

(to be admitted *pro hac vice*)

11 rbrunelli@sheridanross.com

12 Scott R. Bialecki

(to be admitted *pro hac vice*)

13 sbialecki@sheridanross.com

14 Tristan D. Lewis

(to be admitted *pro hac vice*)

15 tlewis@sheridanross.com

16 SHERIDAN ROSS P.C.

1560 Broadway, Suite 1200

17 Denver, CO 80202

18 Telephone: (303) 863-9700

19 Facsimile: (303) 863-0223

litigation@sheridanross.com

20 *Attorneys for Plaintiff K.Mizra LLC*

21 4923-9913-4989.1

22
23
24
25
26
27
28