

**IN THE UNITED STATES DISTRICT COURT
FOR THE WESTERN DISTRICT OF TEXAS
AUSTIN DIVISION**

SILICONARTS TECHNOLOGY US INC.,

Plaintiff,

v.

**NVIDIA CORPORATION, and
NVIDIA SINGAPORE PTE. LTD.,**

Defendants.

Civil Action No. 1:25-cv-431

JURY TRIAL DEMANDED

COMPLAINT FOR PATENT INFRINGEMENT

Plaintiff SiliconArts Technology US Inc. (“Plaintiff” or “SiliconArts Technology”) files this Complaint against Defendants NVIDIA Corporation and NVIDIA Singapore Pte. Ltd. and alleges as follows:

NATURE OF SUIT

1. This is a claim for patent infringement arising under the patent laws of the United States, Title 35 of the United States Code.

THE PARTIES

I. SILICONARTS TECHNOLOGY

2. SiliconArts Technology is a corporation duly organized and existing under the laws of the State of Texas, having a place of business located at 7215 Bosque Boulevard, Suite 211, Waco, Texas, 76710.

3. SiliconArts Technology is the current owner of all rights, title, and interest in and to U.S. Patent No. 9,965,889 (the “’889 Patent,” “Asserted Patent,” or “Patent-in-Suit”), including the right to sue for past damages.

4. The technological developments covered by the Patent-in-Suit have now become a cornerstone of modern ray tracing graphics processing units (“GPUs”)—especially hardware-accelerated, real-time ray tracing cores, chips, and processors—in the United States, including within this District.

5. Such developments in ray tracing are an essential element for realizing realistic graphics in visual effects, animation, film editing, video games, and other applications where processing times have previously limited or prohibited the use of ray tracing and, instead, less desirable and/or less computationally intensive graphic processing techniques such as rasterization have been used.¹

6. The technologies of the Patent-in-Suit have been praised for advancing the field of real-time ray tracing GPU technology—including receiving multiple technology awards.

7. Not surprisingly, NVIDIA has exploited the patented technology, incorporating it into their products and services.

II. NVIDIA

8. Defendant NVIDIA Corporation is a Delaware corporation. NVIDIA Corporation is registered with the State of Texas and may be served with process through its registered agent, Corporation Service Company d/b/a CSC-Lawyers Incorporating Service Company, 211 E. 7th Street, Suite 620, Austin, Texas 78701. NVIDIA maintains a physical facility within this District at 11001 Lakeline Boulevard, Suite #100 Building 2, Austin, Texas 78717.

9. Defendant NVIDIA Singapore Pte. Ltd. (“NVIDIA Singapore”) is an entity organized under the laws of Singapore with a place of business located at 3/F Harbour View 1,

¹ See, e.g., <https://blogs.nvidia.com/blog/whats-difference-between-ray-tracing-rasterization/> for a brief comparison of ray tracing and rasterization.

No. 12 Science Park East Avenue, HK Science Park, Shatin, Hong Kong. NVIDIA Singapore Pte. Ltd. is a wholly owned subsidiary of NVIDIA International, Inc. On information and belief, NVIDIA Singapore may be served at its registered office located at 6001 Beach Road, #15-01, Golden Mile Tower, Singapore 199589, or through an officer or a managing or general agent located in the United States.

10. On information and belief, Defendants NVIDIA Corporation and NVIDIA Singapore (collectively, “NVIDIA” or “Defendants”) make, use, offer for sale, sell in the United States, and/or import into the United States, certain NVIDIA GPUs with RT cores, including at least NVIDIA Turing GPUs (e.g., TU102 and TU106), Ampere GPUs (e.g., GA102 and GA107), Ada Lovelace GPUs (e.g., AD102 and AD107), Blackwell GPUs (e.g., B102), GeForce RTX® 20, 30, 40, and 50 Series GPU products (e.g., GeForce RTX 4060), RTX® GPU products (e.g., RTX 1000 Ada Laptop GPU and RTX 4000 Ada Generation), Quadro™ GPU products (e.g., Quadro RTX 6000), and GPU data center products (e.g., L40, L40S, L4 Tensor Core, A2 Tensor Core, A10 Tensor Core, A40 Tensor Core, A60 Tensor Core, T4), among other substantially similar GPUs and products using the same (e.g., laptops, tablets, desktop computers, servers, mobile devices, etc.) (collectively, the “Accused Products”).

11. NVIDIA offers for sale and sells the Accused Products to numerous customers in the United States, including to customers in this District.

12. Additionally, NVIDIA GPUs with RT cores are employed by NVIDIA servers located in the United States to host NVIDIA cloud services like GeForce NOW for gaming and Omniverse Cloud for professional applications. Thus, NVIDIA also uses the Accused Products in the United States to provide services to customers in the United States, including in this District.

JURISDICTION AND VENUE

13. This Court has subject matter jurisdiction over patent infringement claims pursuant to 28 U.S.C. §§ 1331 and 1338, as those claims arise under the patent laws of the United States (35 U.S.C. §§ 1 *et seq.*).

I. NVIDIA CORPORATION

14. NVIDIA Corporation is subject to this Court’s personal jurisdiction consistent with the principles of due process and/or the Texas Long Arm Statute. Personal jurisdiction exists generally over NVIDIA Corporation because NVIDIA Corporation has sufficient minimum contacts and/or has engaged in continuous and systematic activities in the forum as a result of business conducted within Texas, including in the Western District of Texas. For example, on information and belief, NVIDIA Corporation has committed, and continues to commit the tort of patent infringement in the State of Texas and this District; NVIDIA Corporation purposefully availed itself of the privileges of conducting business in the State of Texas and this District; and NVIDIA Corporation regularly conducts and solicits business—including substantial marketing and sales of products—within the State of Texas and this District.

15. Personal jurisdiction also exists over NVIDIA Corporation because NVIDIA Corporation, directly or through subsidiaries, agents, representatives, or intermediaries makes, uses, sells, offers for sale, imports, advertises, makes available, and/or markets products and/or services within Texas, including in the Western District of Texas, that infringe one or more claims of the Asserted Patent. Further, on information and belief, NVIDIA Corporation has placed or contributed to placing infringing products and/or services into the stream of commerce knowing or understanding that such products and/or services would be sold and used in this District.

16. For fiscal year 2024, NVIDIA Corporation reported \$26.966 billion USD in revenue from sales to customers in the United States. A substantial portion of NVIDIA’s business is the sale of GPUs, including the Accused Products.

17. For example, NVIDIA Corporation offers for sale and/or sells the Accused Products directly to customers in the United States, including in this District, through its official online marketplace, marketplace.nvidia.com, which allows consumers, businesses, and other end users throughout the United States and this District to purchase the Accused Products, including infringing GPUs.

18. NVIDIA Corporation lists at least some of the Accused Products, such as the NVIDIA GeForce RTX 4060 Ti, for purchase through its U.S. Marketplace.

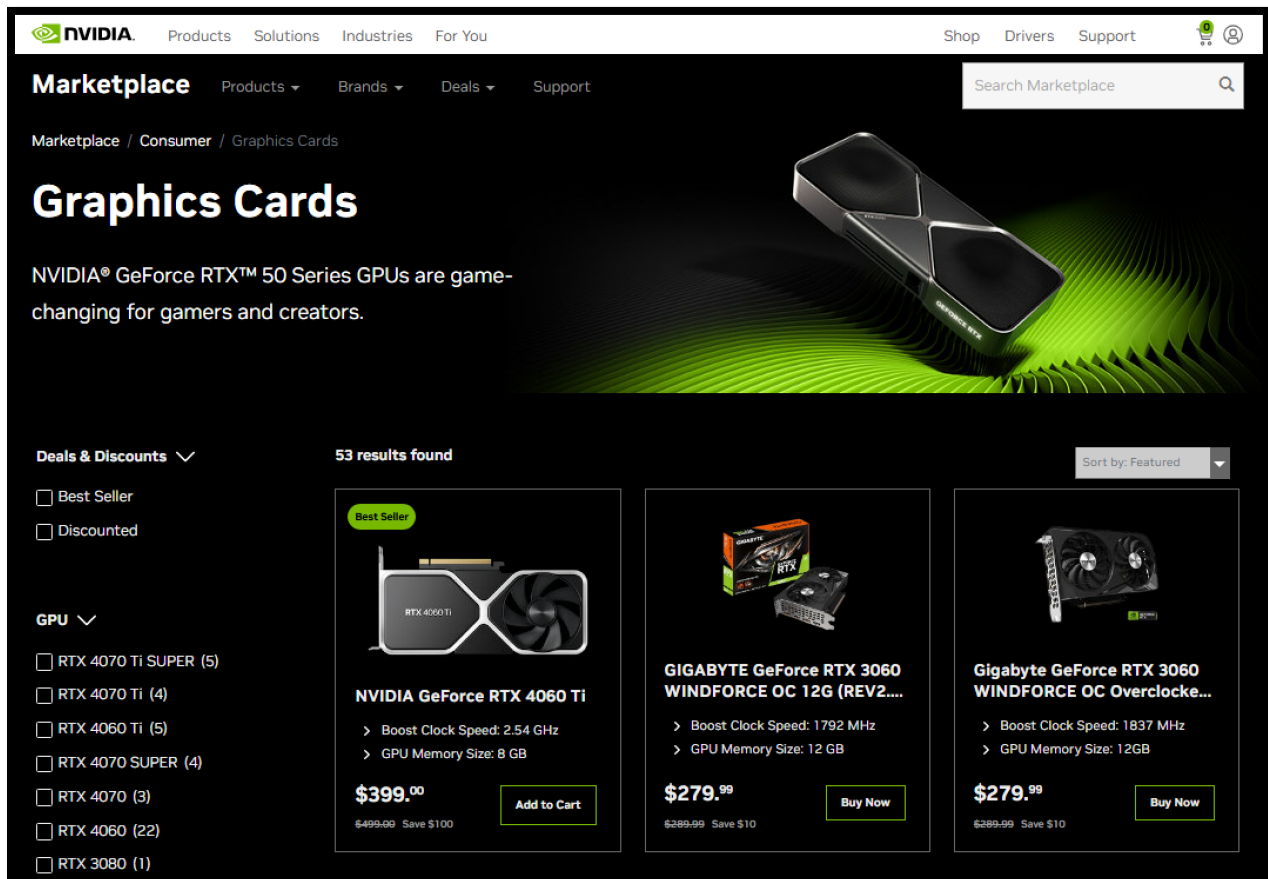

Screenshot of NVIDIA Marketplace US

19. NVIDIA Corporation collects payment from customers for products sold through the Marketplace.

NVIDIA

CART AND BILLING INFO > REVIEW ORDER > ORDER SUBMITTED

CHECKOUT AS GUEST

Have an account? [Sign-in](#)

BILLING ADDRESS

*First Name *Last Name

*Phone Number *Email Address

*Verify Email Address *Address

*City Select State

*Zip/Postal Code United States

Shipping address is different than billing.

SHIPPING METHOD

Free Ground Shipping (5-7 Business Days) \$0.00

ORDER SUMMARY

 NVIDIA GEFORCE RTX 4060 Ti \$399.00
Limit 1 per customer
[Remove](#)

Promo Code [Apply](#)

Shipping (Free Ground Shipping (5-7 Business Days)): Included

Subtotal (tax not included): \$399.00

Screenshot of NVIDIA Marketplace US Shopping Cart

20. NVIDIA Corporation has direct customers, such as add-in board (“AIB”) manufacturers, distributors, original device manufacturers (“ODMs”), original equipment manufacturers (“OEMs”), and system integrators, who purchase products directly from NVIDIA Corporation. On information and belief, at least some of NVIDIA Corporation’s direct customers reside and/or operate within the United States, including within this District.

21. NVIDIA Corporation also has certain customers that may purchase products directly from NVIDIA Corporation and may use either internal resources or third-party system integrators to complete their build. For example, PNY Technologies, Inc. is a New Jersey-based AIB manufacturer of graphics cards, such as the PNY – NVIDIA GeForce RTX 4060 Ti depicted below.



PNY - NVIDIA GeForce RTX 4060 Ti 8GB OC GDDR6 PCIe Gen 4 x16 Graphics Card with Dual Fan – Black

22. At least some of NVIDIA Corporation’s customers purchase indirectly through multiple OEMs, ODMs, system integrators, distributors, and other channel partners.

23. NVIDIA partners with OEMs, ODMs, system integrators, and distributors to help bring NVIDIA products to market. For example, NVIDIA partners with direct customers like PNY to ensure that the Accused Products are available to end customers in the United States, including in this District. For example, the above accused PNY GeForce RTX graphics card was in stock and available to purchase at a Best Buy located at 1201 Barbara Jordan Boulevard, Suite 100, Austin, Texas 78723 in this District.

Best Buy Website Showing NVIDIA GeForce RTX Graphics Cards in Stock in Austin, Texas

24. On information and belief, NVIDIA supports its board partners with extensive co-marketing programs. On further information and belief, NVIDIA and Best Buy have a comprehensive partnership that encourages PC gamers to visit Best Buy stores to purchase products with NVIDIA GPUs.

25. On information and belief, NVIDIA Corporation also has indirect customers, who purchase products through NVIDIA’s direct customers. Indirect customers include cloud service providers, consumer internet companies, enterprises, and public sector entities.

26. As an example, the world's leading cloud service providers and consumer internet companies use NVIDIA Corporation's data center-scale accelerated computing platforms to enable, accelerate or enrich the services they deliver to billions of end users. Some of NVIDIA Corporation's cloud service provider customers in the United States include Amazon Web Services, Google Cloud, Microsoft Azure, Oracle Cloud, and IBM Cloud.

27. On information and belief, NVIDIA also owns and operates GeForce NOW servers physically located in Texas that include Accused Products. Indeed, NVIDIA provides users in this District with live status updates indicating whether such servers (e.g., NP-DAL-04 [RTX 4080]) are, for example, online, offline, or down for maintenance.² These products are operated and marketed by NVIDIA to individual customers in this District who access them for ray tracing technology at issue in this suit. For example, NVIDIA partnered with Google Fiber to host a GeForce NOW event in the Google Fiber Space in Austin, Texas to help promote the GeForce NOW on-demand cloud gaming service.

28. On information and belief, NVIDIA's other cloud services (e.g., NVIDIA's Omniverse Cloud platform) also contribute to infringement within this District. These services utilize NVIDIA GPUs in data centers that provide gaming and AI processing to end-users in this District. NVIDIA encourages and facilitates end-users to access its cloud platforms, knowing these services involve the infringing use of the patented technology. NVIDIA's intentional targeting of users within Texas through these cloud offerings further establishes its direct and indirect infringement within this District.

29. Furthermore, personal jurisdiction over NVIDIA Corporation in this action comports with due process such that an exercise of personal jurisdiction over NVIDIA Corporation

² <https://status.geforcenow.com> (listing NP-DAL-04 [RTX 4080] in US Central region).

would not offend traditional notions of fair play and substantial justice. For example, NVIDIA Corporation has conducted and regularly conducts business within this District; NVIDIA Corporation has purposefully availed itself of the privileges of conducting business in this District; and NVIDIA Corporation has sought protection and benefit from the laws of the State of Texas by placing infringing products into the stream of commerce through an established distribution channel with the awareness and/or intent that they will be purchased by consumers in this District. Having purposefully availed itself of the privilege of conducting business within this District, NVIDIA Corporation should reasonably and fairly anticipate being brought into court here.

30. Accordingly, NVIDIA Corporation has repeatedly acknowledged that this Court has personal jurisdiction over it. *See, e.g., Vantage Micro LLC v. NVIDIA Corp.*, No. 6:19-cv-00582-RP, Dkt. 22 (W.D. Tex., Jan. 4, 2020) (admitting to personal jurisdiction); *Ocean Semiconductor LLC v. NVIDIA Corp.*, No. 6:20-cv-01211-ADA, Dkt. 14 (W.D. Tex., Mar. 12, 2021) (same). Further, NVIDIA has admitted “it is subject to this Court’s general personal jurisdiction.” *E.g., Ocean Semiconductor LLC*, Dkt. 14 at ¶ 27.

31. Venue is proper in the Western District of Texas pursuant to 28 U.S.C. §§ 1391(b)-(c) and/or 1400(b), including but not limited to because NVIDIA Corporation has committed acts of infringement in this District and has a regular and established place of business in this District.

32. On information and belief, NVIDIA Corporation owns and operates Accused Products with ray tracing capabilities in this District, including at 7100 Metropolis Drive, Austin, Texas, 78744.

33. As shown in the photograph below, NVIDIA Corporation maintains a physical office in this District located at 11001 Lakeline Blvd., Suite #100 Bldg. 2, Austin, Texas 78717.

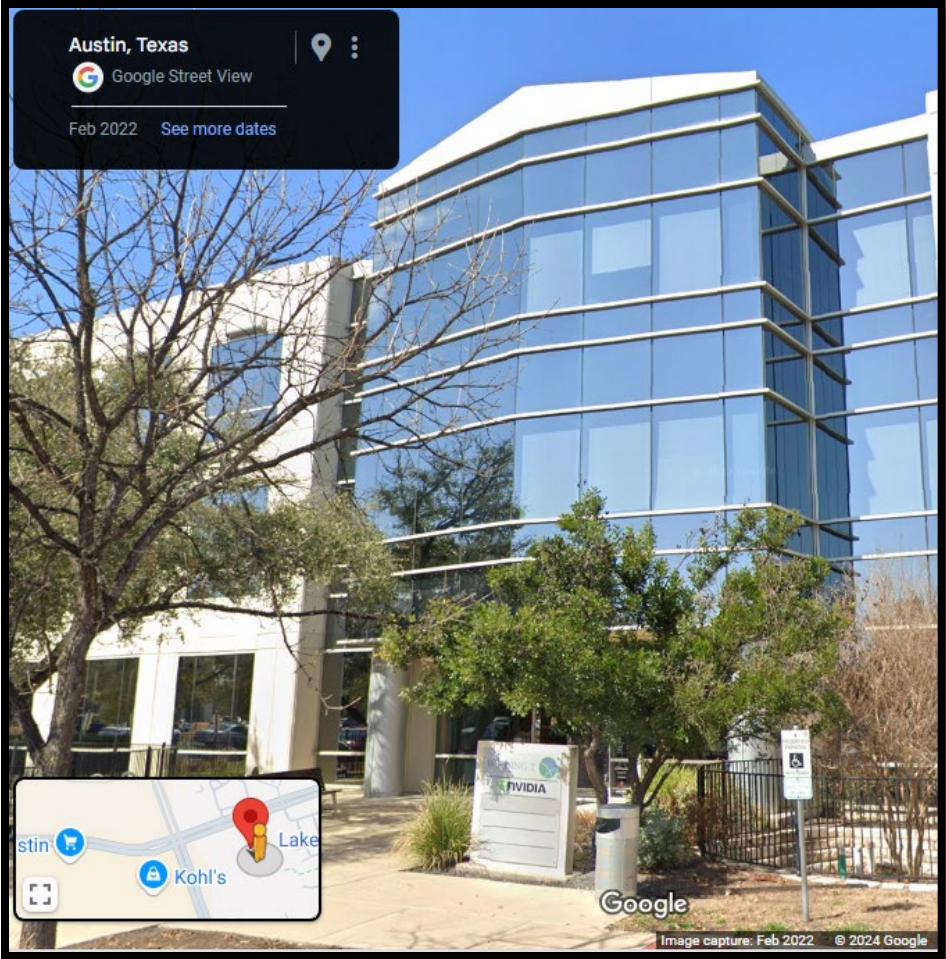

Image of NVIDIA Austin, Texas Office obtained via Google Maps

34. NVIDIA’s office features commercial signage inside and out.



Interior Photograph of NVIDIA's Austin Office³

35. NVIDIA Corporation owns, and pays taxes on, at least its location at 11001 Lakeline Blvd., Suite #100 Bldg. 2, Austin, Texas 78717 identified above.

36. On information and belief, NVIDIA also has an office at 10801 North Mopac Expressway, Austin, Texas 78759.

37. NVIDIA's one or more Austin offices are physical, geographical locations in this District from which NVIDIA carries out its business.

38. On information and belief, NVIDIA employees in this District design, develop, market, sell, and/or support the Accused Products, including from NVIDIA's offices in Austin.

³ <https://kiddgrp.com/project/nvidia-corporation/>

39. NVIDIA's locations in this District are regular and established places of business under 28 U.S.C. § 1391, 28 U.S.C. § 1400(b), and *In re Cray, Inc.*, 871 F.3d 1355, 1360 (Fed. Cir. 2017).

40. In addition, NVIDIA Corporation has not disputed that venue is proper in this District in cases filed against it in this District. *See, e.g., Vantage Micro LLC v. NVIDIA Corp.*, No. 6:19-cv-00582, Dkt. No. 22; *Ocean Semiconductor LLC v. NVIDIA Corp.*, No. 6:20-cv-01211-ADA, Dkt. 14; *Polaris Innovations Ltd. v. Dell Inc. et al.*, No. 5:16-cv-00451, Dkt. No. 19; *Cirrus Logic, Inc. v. ATI Techs., et al.*, No. 1:03-cv-00302, Dkt. No. 6.

II. NVIDIA SINGAPORE

41. NVIDIA Singapore is subject to this Court's personal jurisdiction consistent with the principles of due process and/or the Texas Long Arm Statute. Personal jurisdiction exists over NVIDIA Singapore because NVIDIA Singapore, directly or through parents, subsidiaries, agents, representatives, or intermediaries, makes, uses, sells, offers for sale, imports, advertises, makes available, and/or markets products and/or services within Texas, including in the Western District of Texas, that infringe one or more claims of the Asserted Patent. Further, on information and belief, NVIDIA Singapore has placed or contributed to placing infringing products and/or services into the stream of commerce knowing or understanding that such products and/or services would be sold and used in this District.

42. Furthermore, personal jurisdiction over NVIDIA Singapore in this action comports with due process such that an exercise of personal jurisdiction over NVIDIA Singapore would not offend traditional notions of fair play and substantial justice. For example, NVIDIA Singapore has purposefully availed itself of the privileges of conducting business in this District; and NVIDIA Singapore has sought protection and benefit from the laws of the State of Texas by placing infringing products into the stream of commerce through an established distribution channel with

the awareness and/or intent that they will be purchased by consumers in this District. Having purposefully availed itself of the privilege of conducting business within this District, NVIDIA Singapore should reasonably and fairly anticipate being brought into court here.

43. On information and belief, the principal activity of NVIDIA Singapore consists of sales of graphics processors and media and communication devices. NVIDIA Singapore has purposefully directed its activities at the United States, including Texas.

44. In Fiscal Year 2024, NVIDIA Corporation reported \$60.922 billion USD of revenue. NVIDIA Corporation claims that revenue from sales to customers outside of the United States accounted for 56% and 69% of total revenue for fiscal years 2024 and 2023, respectively. However, on information and belief, at least a portion of revenue from sales to customers that NVIDIA classifies as outside of the United States is nevertheless attributable to indirect customers who reside in the United States.

45. During FY2024, NVIDIA Singapore reported \$43.2 billion USD of revenue from sales of graphics processors and related media and communication devices. NVIDIA Singapore also reported \$43.1 billion USD in expenses from purchase of inventories, including \$39.8 billion USD in inventory purchased from its parent, NVIDIA International, Inc., an indirect, wholly owned subsidiary of NVIDIA Corporation. In addition, NVIDIA Singapore reported \$3.45 billion USD in inventory purchased from a fellow subsidiary.

46. On information and belief, NVIDIA Singapore's inventory purchases reflect approximately 70.7% of NVIDIA Corporation's total revenue for FY2024. However, if NVIDIA claims that only 56% of its total revenue for FY2024 came from sales to customers outside of the United States, then at least a portion of NVIDIA Singapore's revenues must come from sales to customers within the United States.

47. In fact, on information and belief, NVIDIA underestimates the amount of sales made to customers within the United States because its accounting practices rely on “bill to” instead of “ship to” location. For example, NVIDIA Corporation reported quarterly revenue of \$7.697 billion USD associated with Singapore for the period ended October 27, 2024. On information and belief, revenue by geographic region is designated based on the billing location even if the revenue may be attributable to indirect customers, such as enterprises and gamers in a different location.

48. In fact, on information and belief, most shipments associated with Singapore revenue were to locations other than Singapore and shipments to Singapore were insignificant. On information and belief, many of NVIDIA’s customers have business entities in Singapore and use those entities for products destined for the U.S. and the West.

49. On information and belief, during the time period relevant to this lawsuit, including from at least 2019, NVIDIA Singapore intended to serve the United States market with the Accused Products.

50. On information and belief, NVIDIA Singapore’s intent to serve the United States market, including Texas, is demonstrated by the fact that from at least 2019 NVIDIA Singapore supplied Accused Products to direct or indirect customers in the United States.

51. NVIDIA Singapore has not sought to exclude any portion of the United States that includes Texas from its efforts to sell and ship products to the United States, including the Accused Products.

52. The litigation results from injuries that arise out of or relate to those activities.

53. Venue is proper in the Western District of Texas pursuant to 28 U.S.C. § 1391(c)(3) because NVIDIA Singapore is a foreign defendant that may be sued in any judicial district.

FACTUAL ALLEGATIONS

I. ASSERTED PATENT

54. The '889 Patent is entitled "Ray Tracing Core and Ray Tracing Chip Having the Same." The United States Patent and Trademark Office duly and legally issued the '889 Patent on May 8, 2018, from U.S. Patent Application No. 15/078,643, filed on March 23, 2016.

55. The '889 Patent is a Continuation of U.S. Patent Application No. 13/375,112 filed on November 29, 2011, which is a National Stage Application under 35 U.S.C. § 371 of PCT International Patent Application No. PCT/KR2010/003173 filed on May 19, 2010, which claims priority to Korean Application No. KR 10-2009-0046909 filed on May 28, 2009.

56. A true and correct copy of the '889 Patent is attached hereto as **Exhibit A** and is incorporated by reference herein.

57. The '889 Patent generally relates to 3D graphic processing technology, including a ray tracing core and ray tracing chip having the same. For example, a ray tracing core includes a ray tracing generation unit and a plurality of Traversal & Intersection ("T&I") units with Multiple Instruction stream Multiple Data stream ("MIMD") architecture. The ray generation unit generates at least one eye ray based on an eye ray generation information. The eye ray generation information includes, for example, a screen coordinate value. Each of the plurality of T&I units receives the at least one eye ray and checks whether there exists a triangle intersected with the received at least one eye ray. The triangle configures a space.

II. SILICONARTS TECHNOLOGY'S RAY TRACING TECHNOLOGY

58. Traditionally, graphics processing techniques have been "very computationally intensive" and techniques have been generally selected for various applications based on the time

and resources available to render the areas or objects in a scene.⁴ For example, two key graphics techniques include rasterization and ray tracing. “Real-time computer graphics have long used ... rasterization to display three-dimensional objects on a two-dimensional screen” because “[i]t’s fast” ... “even if it’s still not always as good as what ray tracing can do.” *Id.* On the other hand, ray tracing is often limited to applications where more computational resources and longer render times are available, which explains why “ray tracing has gone on to conquer modern moviemaking” where “movie makers rely on vast numbers of servers, or rendering farms,” that “can take days, even weeks, to render complex special effects.” *Id.*

59. “With rasterization, objects on the screen are created from a mesh of virtual triangles, or polygons, that create 3D models of objects. In this virtual mesh, the corners of each triangle — known as vertices — intersect with the vertices of other triangles of different sizes and shapes. A lot of information is associated with each vertex, including its position in space, as well as information about color, texture and its “normal,” which is used to determine the way the surface of an object is facing.” *Id.* Rasterization then converts the polygons of the 3D models into pixels on a 2D screen and further processes the pixels to account for shading and finishing features before generating the final pixel image.

60. Ray tracing, on the other hand, attempts to generate graphics by rendering the effects that real-world light photons experience when they bounce from one object to another before reaching the viewer’s eyes. By working backwards, ray tracing follows the path of a light ray through each pixel on a 2D viewing surface out into a 3D model of a scene. Each time a light ray encounters an object, the point of impact on the object’s surface contributes to color,

⁴ <https://blogs.nvidia.com/blog/whats-difference-between-ray-tracing-rasterization/>

illumination level—resulting in “computer-generated images that capture shadows, reflections and refractions in ways that can be indistinguishable from photographs or video of the real world.” *Id.*

61. While both techniques are computationally intensive, ray tracing is generally considered to be more computationally intensive such that rasterization has been traditionally used in applications where computational power and/or time is limited. For example, ray tracing has been practical when generating realistic graphics for movies scenes and for applications in cinema. However, this application of ray tracing is possible because movie makers can take as long as they like to render a single frame. Accordingly, such ray tracing occurs in offline render farms with the benefit of extensive computational power and ample time to wait for a scene to render.

62. Given the high computational tax and time-intensive nature of ray tracing, rasterization has historically been the primary technique used for generating graphics in applications such as video games—where frames, areas, scenes, and other objects must be generated and rendered in real time (e.g., rendering as the viewer is observing/interacting with the media). While rasterization has yielded acceptable results for rendering some aspects of three-dimensional graphics, ray tracing techniques are widely considered to be superior (e.g., more realistic, more inclusive of reflections/shadows/light, etc.).

63. The ray tracing core and/or ray tracing chip described in the '889 are particularly useful for generating images and graphical effects including realistic reflection, refraction, shadows, and/or shading in real time. The '889 Patent provides devices for hardware accelerated ray-tracing, which is a foundational technique for realizing realistic graphics in content such as movies, games, and simulations. For example, Claim 1 of the '889 Patent is directed to:

1. A ray tracing core comprising:

a ray generation unit configured to generate an eye ray based on eye ray generation information and to generate a shading ray according to a shading ray type based on shading

information, the shading information having a priority over the eye ray generation information and the eye ray generation information including a screen coordinate value;

a plurality of T&I (Traversal & Intersection) units with MIMD (Multiple Instruction stream Multiple Data stream) architecture, each of the plurality of T&I units configured to independently and concurrently process a ray with a corresponding ray type and to check whether there exists a triangle intersected with the received at least one eye ray, the triangle configuring a space in an AS (Acceleration Structure),

wherein for a ray-triangle hit point in the intersected triangle, the shading information is generated for a secondary ray according to material information in the intersected triangle or for a shadow ray for light source, and

wherein each of the plurality of T&I units includes an L1 cache and the ray tracing core includes a common L2 cache for the L1 caches in the plurality of T & I units, and when an L1 cache miss occurs in a current ray, a requirement for an L2 cache access is inputted to L1 Addr (Address) FIFO (First in First Out) and when the L2 cache access is hit, an address and data is inputted to an L1 Addr/Data (Address and Data) FIFO and otherwise, other requirement for an external memory is inputted to an L2 Addr FIFO.

64. The '889 patent solves a technological problem relating to real-time ray tracing, including solving performance limitations of graphics rendering hardware. As the '889 Patent explains, ray tracing technologies generate realistic images by simulating the behavior of light rays but have traditionally suffered from performance issues due to, for example, the large amounts of computations required and inefficiencies inherent in existing architectures. For example, some ray tracing architectures and techniques suffered from pipeline stall time due to cache memory misses, leading to latency and inefficient hardware utilization.

65. To overcome these shortcomings, the '889 Patent claims a specialized ray tracing core with improved features for more effectively performing ray tracing. For example, a ray tracing core of the '889 Patent may support MIMD architecture, allowing the system to independently and

concurrently process a ray with a corresponding ray type, thus significantly reducing processing bottlenecks. Additionally, the ray tracing core may adopt a “unified pipeline architecture” or “unified single pipeline” for traversal and intersection tests, eliminating inefficiencies, such as load imbalance issues, that arose from separate hardware pipelines. Further, the inventions of the ’889 Patent mitigate memory latency issues by employing improved cache management techniques designed to minimize pipeline stall time.

66. Systems, products, processors, and other Accused Products that employ the patented accelerated ray tracing techniques enable rapid, high-performance graphics rendering and processing that generate higher quality graphics than other systems. Further, the technology provides these benefits at lower power and operational costs. The patented inventions significantly reduce the time and/or computational intensity of generating graphics via ray tracing while achieving renderings that account for realistic light, reflections, shadows, refractions, and other illumination phenomena. These improvements are a quantum leap forward from prior systems and bring realistic, cinema-style graphics to media forms where such benefits were previously prohibited by cost and/or time.

67. As noted by tech magazine APAC CIO Outlook:

SiliconArts, a Korean tech startup, developed RayCore, the real-time ray tracing graphics processor (GPU) for the first time in graphics hardware history. RayCore is the next-generation GPU that is used in rendering high-quality 3D graphics whose graphics performance surpasses that of rasterization GPU approach. RayCore, developed by SiliconArts, is a hardware that has overcome the limitations of the existing ray tracing approach, applying all of the benefits of ray tracing to its product that can render cinema-quality 3D graphics effects on real-time basis. Particularly, RayCore is designed to consume the industry’s lowest

power level in order to implement both User Interface and User Experience on mobile platforms and smartphones.⁵

68. The patented accelerated ray tracing technology achieves a leap in graphics quality that eluded the industry for over a decade and that also increases system power optimization and performance. Rather than remaining an unobtainable goal with limited applications, thanks to the patented accelerated ray tracing technology, real-time ray tracing has become practical with newfound applicability to the gaming, entertainment, and graphics processing industries, among others.

III. DEFENDANTS' USE OF SILICONARTS TECHNOLOGY'S PATENTED DEVELOPMENTS

69. As further discussed below, Defendants directly and indirectly infringed—and continue to directly and indirectly infringe—the Asserted Patent under 35 U.S.C. § 271(a)–(c) by making, using, selling, and/or offering for sale in the United States, and/or importing into the United States the Accused Products and by inducing and/or contributing to the direct infringement by third parties (including, for example, NVIDIA's customers in this District and elsewhere in the United States) of at least one claim of the Asserted Patent.

70. Under typical configurations, the Accused Products provide real-time ray tracing while enjoying other benefits of the patented technology, such as a lower latency from the hardware stack of the Accused Products.

71. Hardware accelerated real-time ray tracing provides greatly enhanced visual graphics that account for illumination, shadows, reflection, and light refraction without sacrificing power usage and at greatly reduced computational cost. Such real-time ray tracing makes

⁵ <https://hpc.apacciooutlook.com/vendors/top-10-hpc-companies-2019-rid-266.html>

previously unachievable cinema-quality graphics available for digital media such as movies, video games, virtual simulation applications, and other media.

72. Certain of the Accused Products, such as NVIDIA's Turing GPUs released years after the priority date of the Patent-in-Suit, provide "a new core GPU architecture that enables major advances in efficiency and performance for PC gaming, professional graphics applications, and deep learning inferencing."⁶ Specifically, the Turing architecture uses "hardware-based accelerators and a Hybrid Rendering approach" to provide "rasterization, real-time ray tracing, AI, and simulation to enable incredible realism in PC games, amazing new effects powered by neural networks, cinematic-quality interactive experiences, and fluid interactivity when creating or navigating complex 3D models."⁷ The Turing GPU architecture implements hardware accelerated ray tracing that "sav[es] the [streaming multiprocessor] from spending the thousands of instruction slots per ray" as shown in the graphic below:

⁶ See, e.g., <https://developer.nvidia.com/blog/nvidia-turing-architecture-in-depth/>.

⁷ *Id.*

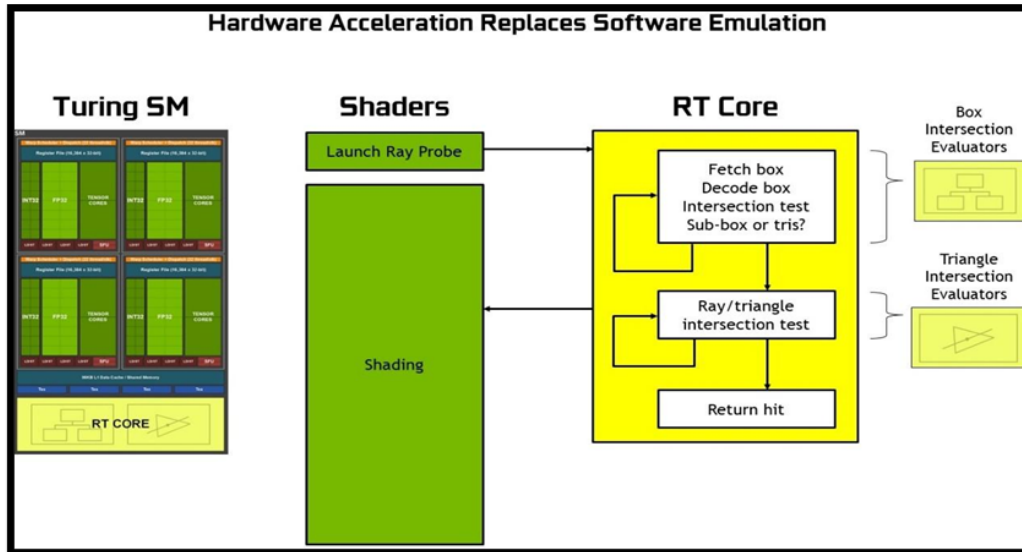

NVIDIA Figure showing Turing Ray Tracing with RT Cores⁸

73. NVIDIA has stated that “the key enablers for Turing’s significant boost in graphics performance are a new GPU processor (streaming multiprocessor—SM) architecture with improved shader execution efficiency, and a new memory system architecture that includes support for the latest GDDR6 memory technology.”⁹ On information and belief, one or more of these key enablers are elements of and/or are covered by the scope of the Patent-in-Suit.

74. NVIDIA values the technology associated with the Accused Products, and products incorporating the Accused Products, and has openly characterized the subject matter of the Asserted Patent as “[t]he long-sought after holy-grail of computer graphics rendering.” *Id.* Further, NVIDIA explains that this “holy grail of computer graphics rendering—real-time ray tracing—is now reality in single-GPU systems with the NVIDIA Turing GPU architecture.”¹⁰

⁸ *Id.*

⁹ *Id.*

¹⁰ *Id.*

75. NVIDIA advertises the Accused Products on its website and specifically calls out the Accused Products' "Ray Tracing" capabilities to incentivize purchases and raise consumer interest.¹¹

COUNT I: INFRINGEMENT OF THE '889 PATENT

76. SiliconArts Technology incorporates by reference the preceding paragraphs as though fully set forth herein.

I. DIRECT INFRINGEMENT

77. In violation of 35 U.S.C. § 271(a), Defendants have directly infringed, and continue to infringe, one or more claims of the Asserted Patent, including at least Claim 1, by making, using, selling, offering for sale, and/or importing the Accused Products in the United States, including within the Western District of Texas, without authorization.

78. By facilitating these sales and deliveries in the United States, including in this District, Defendants engage in infringing acts within the meaning of 35 U.S.C. § 271(a).

79. Defendants are infringing claims of the '889 Patent, including at least Claim 1, literally and/or pursuant to the doctrine of equivalents.

80. Claim 1 of the '889 Patent is directed to:

1. A ray tracing core comprising:

a ray generation unit configured to generate an eye ray based on eye ray generation information and to generate a shading ray according to a shading ray type based on shading information, the shading information having a priority over the eye ray generation information and the eye ray generation information including a screen coordinate value;

a plurality of T&I (Traversal & Intersection) units with MIMD (Multiple Instruction stream Multiple Data stream) architecture, each of the plurality of T&I units configured to independently and concurrently process a ray with a

¹¹ <https://www.nvidia.com/en-us/geforce/graphics-cards/40-series/rtx-4090/>

corresponding ray type and to check whether there exists a triangle intersected with the received at least one eye ray, the triangle configuring a space in an AS (Acceleration Structure),

wherein for a ray-triangle hit point in the intersected triangle, the shading information is generated for a secondary ray according to material information in the intersected triangle or for a shadow ray for light source, and

wherein each of the plurality of T&I units includes an L1 cache and the ray tracing core includes a common L2 cache for the L1 caches in the plurality of T & I units, and when an L1 cache miss occurs in a current ray, a requirement for an L2 cache access is inputted to L1 Addr (Address) FIFO (First in First Out) and when the L2 cache access is hit, an address and data is inputted to an L1 Addr/Data (Address and Data) FIFO and otherwise, other requirement for an external memory is inputted to an L2 Addr FIFO.

81. The Accused Products practice every element of one or more claims of the '889 Patent, including at least Claim 1.

82. The Accused Products have a ray tracing core. For example, the Turing, Ampere, Ada, and Blackwell products include, for example, at least one graphics processing cluster (“GPC”) and a shared L2 Cache:



AD102 GPU with Multiple GPCs¹²

83. In the Accused Products, each GPC includes one or more streaming multiprocessors (“SM”):

¹² <https://images.nvidia.com/aem-dam/Solutions/geforce/ada/nvidia-ada-gpu-architecture.pdf> at 7.

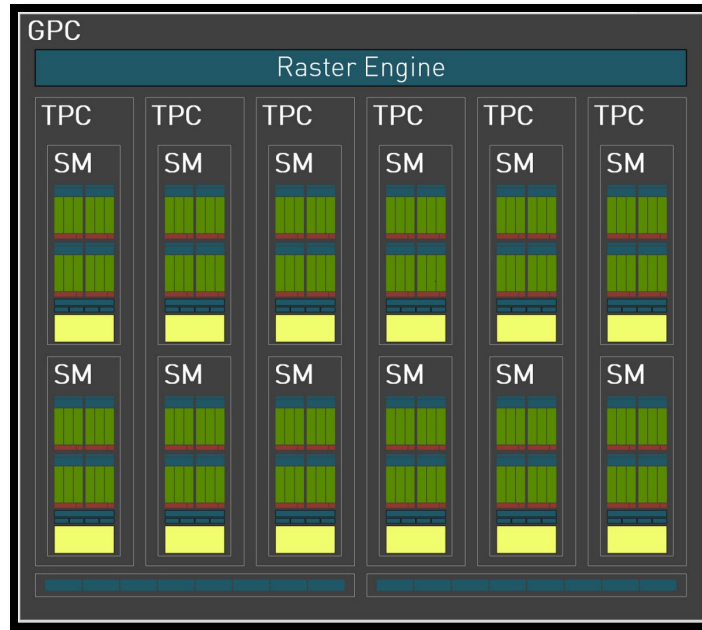

One of the GPCs in the AD102 GPU¹³

84. The Accused Products include at least one ray generation unit such as a central processing core within the SM. For example, each SM in the AD10x GPUs contains 128 CUDA Cores (e.g., “Programmable Shading Cores” or “Shaders”):

¹³ <https://images.nvidia.com/aem-dam/Solutions/geforce/ada/nvidia-ada-gpu-architecture.pdf> at 8.

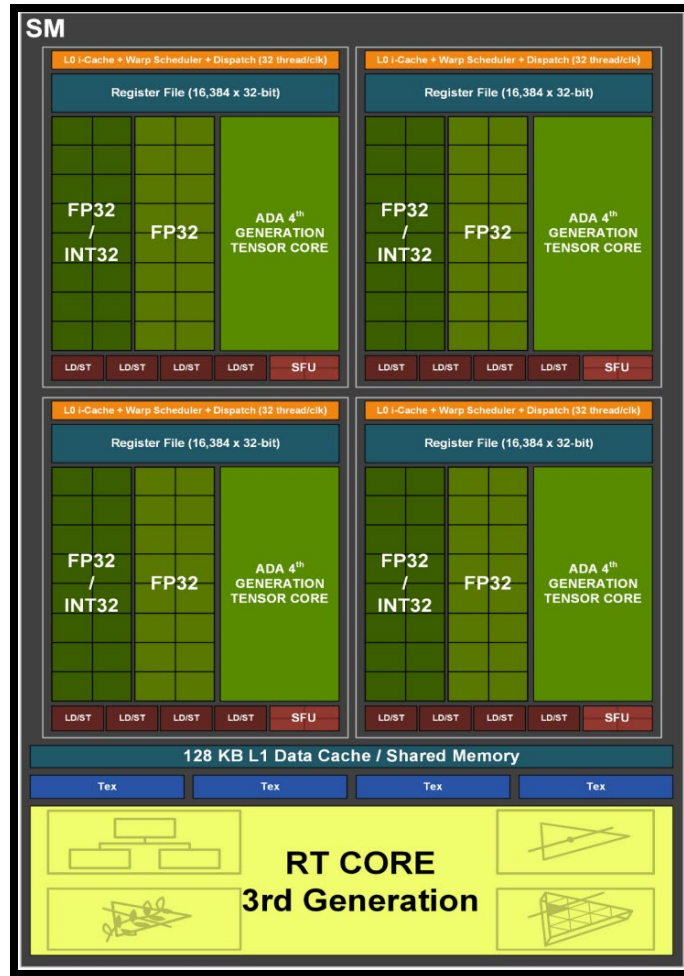

AD10x SM includes FP32 CUDA Cores¹⁴

85. On information and belief, CUDA Cores/Shader and/or other features in the Accused Products include a ray generation unit configured by NVIDIA to generate an eye ray based on eye ray generation information and to generate a shading ray according to a shading ray type based on shading information.¹⁵

¹⁴ <https://images.nvidia.com/aem-dam/Solutions/geforce/ada/nvidia-ada-gpu-architecture.pdf> at 11.

¹⁵ See, e.g., <https://images.nvidia.com/aem-dam/Solutions/geforce/ada/nvidia-ada-gpu-architecture.pdf> at 10 (noting that each partition contains “16 CUDA Cores that are dedicated for processing FP32 operations (up to 16 FP32 operations per clock)”).

86. In the Accused Products, a CUDA Core implements a shader which performs various kinds of shading operations such as vertex shading, pixel shading, and geometry shading. Generating an eye ray (e.g., a primary ray or a view ray) is also one of the shading operations.

87. In the Accused Products, shading information has a priority over the eye ray generation information. For example, when calculating a reflection from a floor, the Accused Products generate a reflection ray after shading, rather than immediately generating a new eye ray, which means shading information at the hit point has a higher priority than eye ray generation information as recited in Claim 1.

88. Additionally, the Accused Products include a ray generation unit configured to generate an eye ray based on eye ray generation information where “the eye ray generation information includ[es] a screen coordinate value” as recited in at least Claim 1. For example, as illustrated by the cited NVIDIA programming guide, the variables eye, U, V, and W allow the host API to specify the position and orientation of the camera.¹⁶ A variable “direction” for eye ray generation is derived by normalizing the camera’s orientation (U, V, W) relative to the screen coordinates and this variable indicates where the ray is projected onto the screen from the eye.

89. Further, on information and belief, the Accused Products include “a plurality of T&I (Traversal & Intersection) units with MIMD (Multiple Instruction stream Multiple Data stream) architecture, each of the plurality of T&I units configured to independently and concurrently process a ray with a corresponding ray type” as recited in Claim 1. As explained in NVIDIA’s Ampere GA102 GPU Architecture:¹⁷

¹⁶ NVIDIA OptiX 6.0 Programming Guide 51–54, https://github.com/CSE168sp20/CSE-168-OptiX-Tutorial/blob/master/OptiX_Programming_Guide_6.5.0.pdf.

¹⁷ <https://images.nvidia.com/aem-dam/en-zz/Solutions/geforce/ampere/pdf/NVIDIA-ampere-GA102-GPU-Architecture-Whitepaper-V1.pdf> at 21.

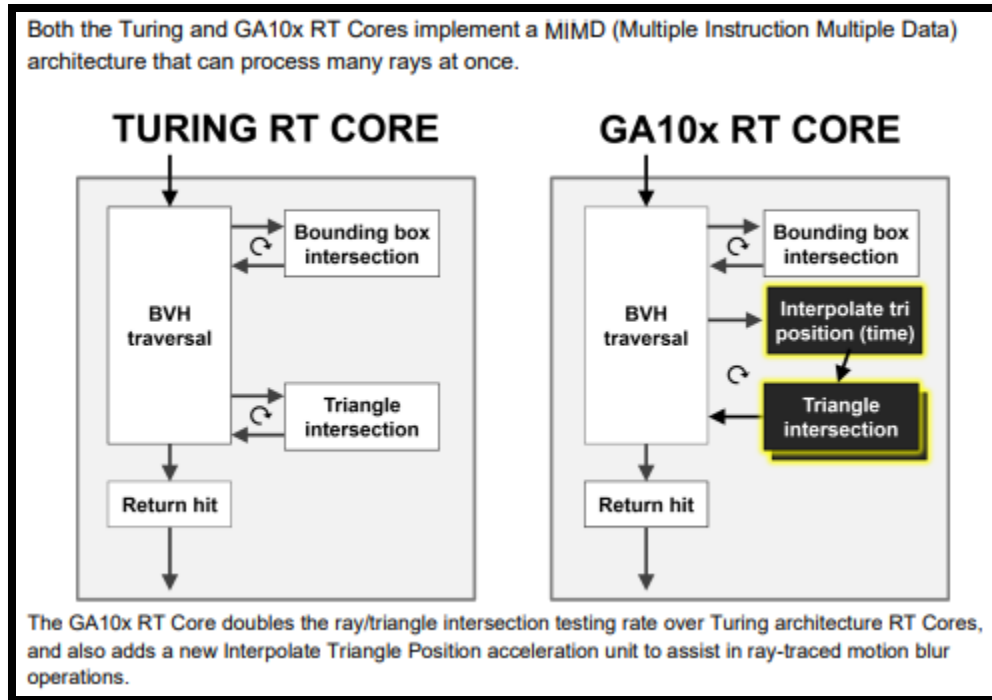

90. The SM, in Turing and Ampere architectures for example, processes thousands of generated ray threads independently and concurrently with a corresponding ray type. A particular type of shader (e.g., any hit shader, closest hit shader) takes that type into account when processing a ray.

91. As an additional example, “each of the plurality of T&I units [is] configured to independently and concurrently process a ray with a corresponding ray type and to check whether there exists a triangle intersected with the received at least one eye ray, the triangle configuring a space in an AS (Acceleration Structure)” as recited in Claim 1. NVIDIA’s Turing GPU Architecture illustrates examples of such elements:

The RT Cores in Turing can process all the BVH traversal and ray-triangle intersection testing, saving the SM from spending the *thousands of instruction slots per ray*, which could be an enormous amount of instructions for an entire scene. *The RT Core includes two specialized units. The first unit does bounding box tests, and the second unit does ray-triangle intersection tests.* The SM only has to launch a ray probe, and the RT core does the BVH traversal

and ray-triangle tests, and return a hit or no hit to the SM. *The SM is largely freed up to do other graphics or compute work.*¹⁸

92. As a further example, “each of the plurality of T&I units [is] configured to” “check whether there exists a triangle intersected with the received at least one eye ray, the triangle configuring a space in an AS (Acceleration Structure),” as recited in at least Claim 1. As discussed in the NVIDIA Turing Architecture Whitepaper, the Accused Products use “a tree-based acceleration structure that contains multiple hierarchically-arranged bounding boxes (bounding volumes) that encompass or surround different amounts of scene geometry.”¹⁹ The below figure illustrates one such ray-tracing acceleration structure in the Accused Products:

¹⁸ <https://images.nvidia.com/aem-dam/en-zz/Solutions/design-visualization/technologies/turing-architecture/NVIDIA-Turing-Architecture-Whitepaper.pdf> at 30 (emphasis added).

¹⁹ <https://images.nvidia.com/aem-dam/en-zz/Solutions/design-visualization/technologies/turing-architecture/NVIDIA-Turing-Architecture-Whitepaper.pdf> at 70.

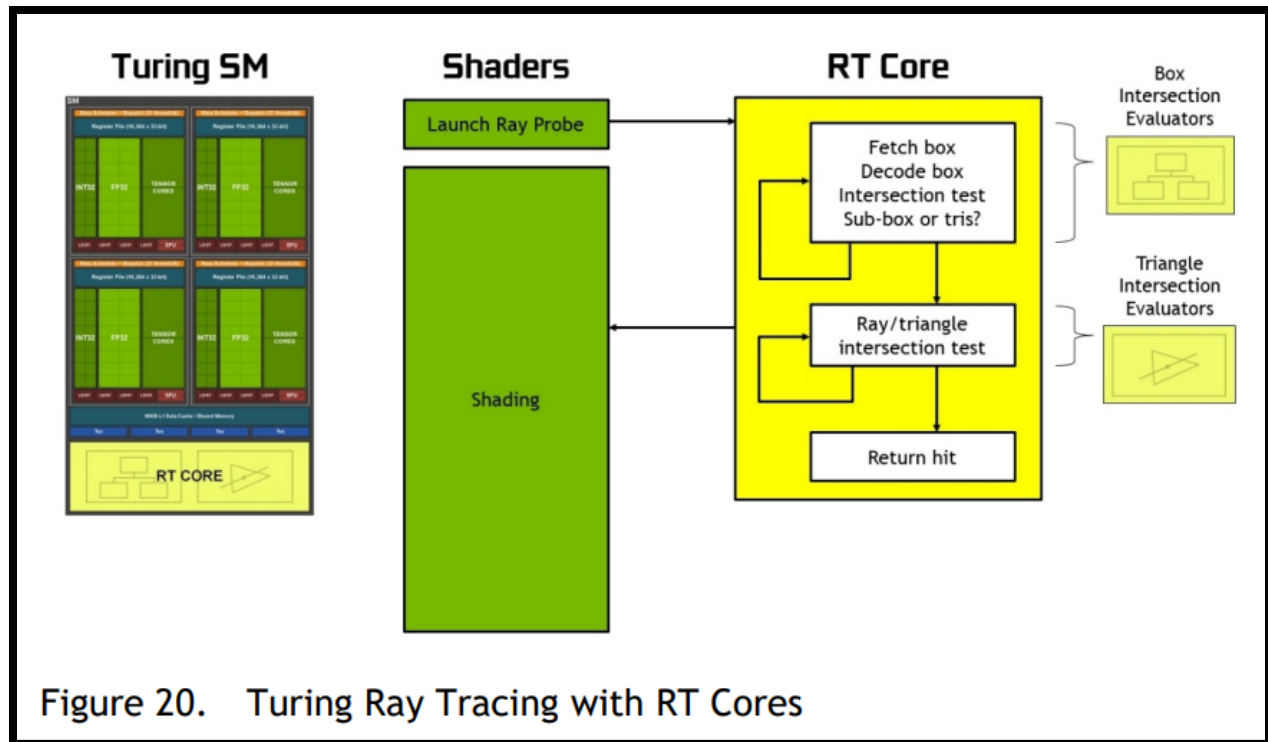

Showing acceleration structure of an Accused NVIDIA Product²⁰

93. The Accused Products also comprise a ray tracing core “wherein for a ray-triangle hit point in the intersected triangle, the shading information is generated for a secondary ray according to material information in the intersected triangle or for a shadow ray for light source,” as recited in at least Claim 1 of the Asserted Patent. For example, the Accused Products are capable of supporting a closest hit shader that can perform material shading at the hit point in the intersected triangle. Specifically, when an RT Core performs the Traversal & Intersection test to find the hit point, shading information necessary to generate a next ray (i.e., a secondary ray and a shadow ray) by the SM is generated.

²⁰ See <https://images.nvidia.com/aem-dam/en-zz/Solutions/design-visualization/technologies/turing-architecture/NVIDIA-Turing-Architecture-Whitepaper.pdf> at 31.

94. The ray generation unit is further configured “to generate a shading ray according to a shading ray type based on shading information” wherein “the shading information is generated for a secondary ray according to material information in the intersected triangle or for a shadow ray for light source” as recited in Claim 1. The Accused Products are capable of supporting different types of rays with different processing purposes, for example, rays to compute color values at the hit point and shadow rays to determine visibility of light sources.²¹

95. Additionally, each of the plurality of T&I units in the Accused Products includes an L1 cache, and the ray tracing core includes a common L2 cache for the L1 caches in the plurality of T&I units. Each RT Core is coupled to an L1 cache and has a common L2 cache for the L1 caches, as shown in the following teardown of an RTX 4060:

²¹ See NVIDIA OptiX 6.0 Programming Guide at 10, 56, 58, https://github.com/CSE168sp20/CSE-168-OptiX-Tutorial/blob/master/OptiX_Programming_Guide_6.5.0.pdf.

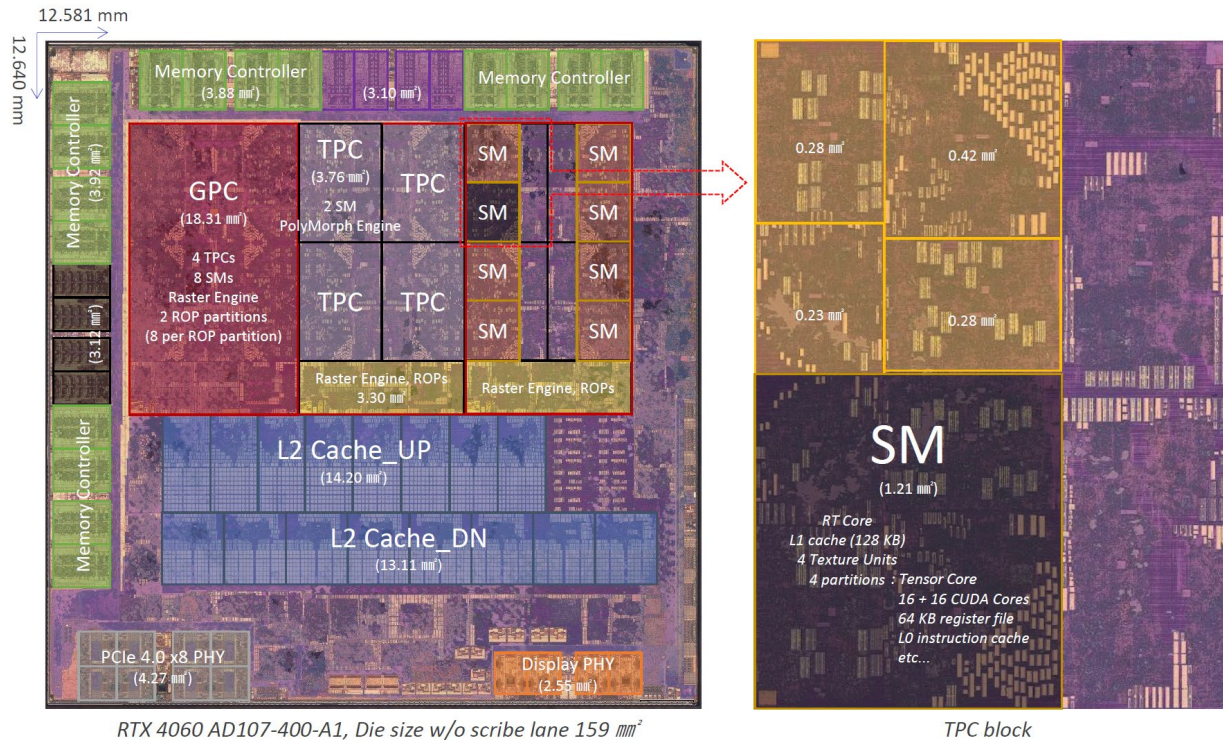

96. The Accused Products also comprise a ray tracing core wherein, “when an L1 cache miss occurs in a current ray, a requirement for an L2 cache access is inputted to L1 Addr (Address) FIFO (First in First Out) and when the L2 cache access is hit, an address and data is inputted to an L1 Addr/Data (Address and Data) FIFO and otherwise, other requirement for an external memory is inputted to an L2 Addr FIFO,” as recited in at least Claim 1.

97. For example, NVIDIA’s Kernel Profiling Guide discloses cache model architectures for GA100 (Ampere, RTX 30 Series) and RTX 2080 Ti (Turing) Accused Products. According to the Kernel Guide, there is a Load Store Unit (LSU) for “pipeline” data process and Miss Stages for each of L1 and L2 caches.²² Additionally, NVIDIA has explained that its “pipelines” operate in FIFO (First in First Out) order:²³

²² <https://docs.nvidia.com/nsight-compute/2022.3/ProfilingGuide/index.html#memory-tables-11>

²³ <https://docs.nvidia.com/cuda/cuda-c-programming-guide/index.html#pipeline-interface>

A `pipeline object` is a double-ended queue with a *head* and a *tail*, and is used to process work in a first-in first-out (FIFO) order. Producer threads commit work to the pipeline's head, while consumer threads pull work from the pipeline's tail. In the example above, all threads are both producer and consumer threads. The threads first `commit memcpy_async` operations to fetch the *next* batch while they *wait* on the *previous* batch of `memcpy_async` operations to complete.

98. By facilitating these sales and deliveries in the United States, including in this District, NVIDIA engages in infringing acts within the meaning of 35 U.S.C. § 271(a).

99. On information and belief, NVIDIA imports Accused Products into the United States for sale via its U.S. website and/or offers for sale the accused infringing products discussed above directly to individuals in the United States, including in this District, through its U.S. website.

100. On information and belief, NVIDIA further directly infringed, and continues to infringe, one or more claims of the Asserted Patent by importing into the United States and/or using Accused Products within the United States via operation of NVIDIA cloud computing infrastructure in the United States that includes Accused Products.

101. As an example, NVIDIA operates a cloud gaming service marketed as GeForce NOW that enables subscribers to stream PC games “directly from GeForce RTX GPUs” to experience incredibly realistic effects with “*Real-Time Ray Tracing* with RTX On.”²⁴

102. On information and belief, NVIDIA owns and operates GeForce NOW servers physically located in Texas that include Accused NVIDIA Products. Indeed, NVIDIA provides users in this District with live status updates indicating whether such servers (e.g., NP-DAL-04 [RTX 4080]) are online, offline, down for maintenance.²⁵

²⁴ <https://www.nvidia.com/en-us/geforce-now/> (emphasis added).

²⁵ <https://status.geforcenow.com> (listing NP-DAL-04 [RTX 4080] in the US Central region).

103. In addition, NVIDIA operates Omniverse Cloud, which enables users to collaboratively create, simulate, and render 3D content in real-time, leveraging its GPUs' ray tracing capabilities through NVIDIA-operated infrastructure and data centers in the United States. NVIDIA's Graphics Distribution Network ("GDN") further supports these activities by delivering high-fidelity, interactive 3D experiences to end-users, relying on Accused Products to process and render 3D content via cloud infrastructure. By deploying, operating, and offering these services to users in the United States, including within this District, NVIDIA engages in acts of making, using, offering for sale, and selling patented systems.

104. Additionally, NVIDIA owns and operates the NVIDIA GDN as part of Omniverse Cloud. As stated by NVIDIA's CEO, Jensen Huang, NVIDIA's GDN and its use of the Accused Products is so extensive that, "[t]hrough GeForce NOW, [NVIDIA has] built a global GDN, a Graphics Delivery Network that reaches 100 regions with super-fast and responsive RTX graphics."²⁶

105. Further, according to NVIDIA, "[t]he backbone of GDN is [the accused infringing] NVIDIA L40 series GPUs based on the NVIDIA Ada Lovelace architecture, including NVIDIA L40 and L40S."²⁷ These products include "third-generation RT Cores that enhance [and provide] real-time ray tracing capabilities" at issue in this suit.

II. INDIRECT INFRINGEMENT

106. NVIDIA has actual knowledge of the '899 Patent, and its infringement thereof described above, at least as of the date of filing of this Complaint.

²⁶ <https://www.youtube.com/watch?v=PWcNIRI00jo> (GTC Sept 2022 Keynote with NVIDIA CEO Jensen Huang).

²⁷ <https://developer.nvidia.com/blog/revolutionizing-cloud-gaming-and-graphics-rendering-with-nvidia-gdn/>.

107. In violation of 35 U.S.C. § 271(b), NVIDIA is and has been infringing one or more of the '889 Patent's claims, including at least Claim 1, indirectly by inducing the direct infringement committed by others, such as NVIDIA's customers and end-users, in this District and elsewhere in the United States. For example, NVIDIA's customers and/or end-users directly infringe via their use of the Accused Products and/or their manufacture, use, sales, and/or offers for sale in the United States and/or importation into the United States of other products that incorporate the Accused Products in manners that infringe the '889 Patent, including at least Claim 1.

108. On information and belief, NVIDIA furnishes instructive materials, technical support, and information concerning the operation and use of the Accused Products and markets and advertises such products on its website, in videos, at conferences, and elsewhere to induce third parties, including NVIDIA's customers and/or end-users to use the Accused Products, and/or to make, use, sell, and/or offer for sale in the United States and/or import into the United States other products incorporating the Accused Products in manners that would infringe one or more of the claims of the '889 Patent, including at least Claim 1.

109. NVIDIA further has indirectly infringed, and continues to infringe, the Asserted Patent within the Western District of Texas by inducing infringement by its retail partners, distributors, and system-integrators located in this District.

110. NVIDIA encourages sales of the Accused Products by advertising the products on its U.S. marketplace. For example, NVIDIA's U.S. marketplace includes a range of infringing NVIDIA-partner products featuring GPUs with ray tracing capabilities. These include GeForce RTX graphics cards, such as the ZOTAC Gaming GeForce RTX 4060 Ti Twin Edge OC White Edition, which support advanced graphics performance. The marketplace also offers gaming

laptops, including models like the Razer Blade 18 with an RTX 4090 Laptop GPU, and gaming desktops such as the CyberPowerPC SLCAI6800CPG with an RTX 4070 SUPER GPU. Studio laptops and desktops, such as the ASUS ZenBook Pro 16X with an RTX 4070 GPU, are available for creative professionals engaging in tasks like video editing and 3D rendering.

111. NVIDIA directs consumers how to purchase these products from retail partners, such as Best Buy, Amazon, Microcenter, and Newegg. For example, NVIDIA lists sales information about the Accused Products, including price, advertised discounts, and whether the product is out of stock. NVIDIA also provides buttons labeled “Buy Now” that link directly to partner product pages where the sale can be completed for a selected item.

112. NVIDIA encourages its retail partners to import, offer for sale, and/or sell Accused Products to customers in the United States. On information and belief, NVIDIA provides marketing materials and technical documentation to these retailers to facilitate their sales efforts, knowing that the resulting transactions involve infringing use of the patented technology by customers in the United States, including in this District.

113. At a minimum, NVIDIA has had actual notice of the ’889 Patent since the filing of this Complaint, yet continues to induce infringement of at least Claim 1 of the ’889 Patent by its customers and end-users.

114. In violation of 35 U.S.C. § 271(c), NVIDIA is and has been infringing one or more of the ’889 Patent’s claims, including at least Claim 1, indirectly by contributing to the direct infringement committed by others, such as NVIDIA’s customers and end-users, in this District and elsewhere in the United States. For example, NVIDIA’s customers and/or end-users directly infringe via their use of the Accused Products in the United States, and/or their manufacture, use, sales, and/or offers for sale in the United States and/or importation into the United States of other

products that incorporate the Accused Products in manners that infringe the '889 Patent, including at least Claim 1.

115. NVIDIA makes and sells hardware and/or software components especially made or especially adapted to practice the invention claimed in the '889 Patent, including at least Claim 1, and that (i) is a material part of the invention and (ii) is not a staple article or commodity of commerce suitable for substantial non-infringing use at least because it is specifically designed to perform the claimed functionality. Any other use of such hardware and/or software would be unusual, far-fetched, illusory, impractical, occasional, aberrant, or experimental.

116. On information and belief, NVIDIA supplies hardware, firmware, and/or software, including software drivers, that are especially made or especially adapted to practice the inventions claimed in the '889 Patent, including at least Claim 1, to induce third parties, including for example NVIDIA's customers and/or end-users, to use the Accused Products in the United States, and/or to make, use, sell, and/or offer for sale in the United States and/or import into the United States other products incorporating the Accused Products in manners that would infringe one or more of the claims of the '889 Patent, including at least Claim 1.

117. As an example, NVIDIA contributes to infringement by enabling OEMs and system integrators located in the United States, including in this District, such as Dell Technologies (based in Round Rock, Texas) and BOXX Technologies LLC (based in Austin, Texas), to sell and/or operate products incorporating the Accused Products in manners that infringe the '889 Patent, including at least Claim 1.

118. Dell and BOXX incorporate Accused Products, including infringing GPUs and corresponding software drivers, into their computer systems, which are offered for sale and sold to customers in Austin and other parts of this District. By supplying these specially designed

components, NVIDIA has provided the means to directly infringe the Asserted Patent, knowing that such infringement would occur.

119. The incorporation of Accused Products into Dell's computing systems makes those computing systems more valuable to Dell's customers.

120. The incorporation of Accused Products into BOXX's computing systems makes those computing systems more valuable to BOXX's customers.

121. Therefore, NVIDIA has contributed to the infringement by others of one or more of the claims of the '889 Patent, including at least Claim 1.

III. WILLFUL INFRINGEMENT

122. At a minimum, Defendants have had actual notice of the '889 Patent, and their infringement thereof, at least as of the filing of this Complaint, yet continue to infringe the '889 Patent, including at least Claim 1.

123. Therefore, on information and belief, Defendants' infringement of the '889 Patent has been and continues to be willful, wanton, malicious, bad-faith, deliberate, consciously wrongful, flagrant, or characteristic of a pirate, entitling SiliconArts Technology to increased damages pursuant to 35 U.S.C. § 284 and to attorneys' fees and costs incurred in prosecuting this action pursuant to 35 U.S.C. § 285.

DAMAGES

124. Defendants' acts of infringement have caused damages to SiliconArts Technology, and SiliconArts Technology is entitled to recover from Defendants the damages sustained by SiliconArts Technology as a result of Defendants' wrongful acts in an amount to be determined at trial.

125. SiliconArts Technology is entitled to, and now seeks to, recover damages in an amount not less than the maximum amount permitted by law caused by Defendants' acts of infringement, including for damages arising before the filing of the complaint.

126. As a result of Defendants' acts of infringement, SiliconArts Technology has suffered actual and consequential damages. To the fullest extent permitted by law, SiliconArts Technology seeks recovery of damages in an amount to compensate for Defendants' infringement. SiliconArts Technology further seeks any other damages to which SiliconArts Technology would be entitled to in law or in equity.

ATTORNEYS' FEES

127. SiliconArts Technology is entitled to recover reasonable and necessary attorneys' fees under applicable law.

DEMAND FOR JURY TRIAL

128. Pursuant to Rule 38 of the Federal Rules of Civil Procedure, SiliconArts Technology demands a trial by jury on all issues so triable.

PRAYER FOR RELIEF

WHEREFORE, SiliconArts Technology prays for judgment and requests that the Court find in its favor and against Defendants. SiliconArts Technology respectfully requests that the Court enter preliminary and final orders, declarations, and judgments against Defendants as are necessary to provide SiliconArts Technology with the following relief:

- a. A judgment that Defendants' have infringed and/or are infringing one or more claims of the Asserted Patent, literally or under the doctrine of equivalents, and directly or indirectly, as alleged above;
- b. A judgment that Defendants' infringement of the claims of the Asserted Patent has been willful;

- c. An award for all damages and costs arising out of Defendants' infringement, to adequately compensate SiliconArts Technology for Defendants' infringement of the Asserted Patent, but in no event less than a reasonable royalty, including an accounting of damages up to any verdict as well as supplemental damages for any continuing post-verdict infringement up until entry of the final judgment, with an accounting, as needed;
- d. Pre-judgment and post-judgment interest, jointly and severally, in an amount according to proof;
- e. Treble damages based on Defendants' willful infringement;
- f. An accounting of damages and any future compensation due to SiliconArts Technology for Defendants' infringement (past, present, or future) not specifically accounted for in a damages award (or other relief), and/or permanent injunctive relief;
- g. A judgment that this case is exceptional and an award of reasonable attorneys' fees as provided by 35 U.S.C. § 285 and enhanced damages as provided by 35 U.S.C. § 284;
- h. An award of costs of suit;
- i. All further relief in law or in equity as the Court may deem just and proper.

DATED: March 21, 2025

Respectfully submitted,

/s/ Austin C. Teng

Max Ciccarelli

State Bar No. 00787242

CICCARELLI LAW FIRM

100 N. 6th Street, Suite 503

Waco, Texas 76701

Telephone: 214-444-8869

Email: max@ciccarellilawfirm.com

Austin C. Teng

State Bar No. 24093247

Nadia E. Haghghatian

State Bar No. 24087652

Daniel S. Shuminer

State Bar No. 24124688

WINSTEAD PC

600 W. 5th Street, Suite 900

Austin, Texas 78701

Tel.: (512) 370-2800

Fax: (512) 370-2850

Email: ateng@winstead.com

nhaghghatian@winstead.com

dshuminer@winstead.com

Jamie H. McDole

State Bar No. 24082049

Phillip Philbin

State Bar No. 15909020

Michael D. Karson

State Bar No. 24090198

Cody M. Carter

State Bar No. 24131091

WINSTEAD PC

2728 N. Harwood Street, Suite 500

Dallas, Texas 75201

Tel.: (214) 745-5400

Fax: (214) 745-5390

Email: jmcdole@winstead.com

pphilbin@winstead.com

mkarson@winstead.com

ccarter@winstead.com

Attorneys for Plaintiff

SiliconArts Technology US Inc.