



Fee Paid
SI
14

1
2
3
4
5
6
7
8
9
10
11
12
13
14
15
16
17
18
19
20
21
22
23
24
25
26
27
28

David M. Barkan (#160825/barkan@fr.com)
FISH & RICHARDSON P.C.
500 Arguello St., Suite 500
Redwood City, CA 94063
Telephone: (650) 839-5070
Facsimile: (650) 839-5071

E-FILING

Filed

NOV 05 2007

Barry K. Shelton (#199307; shelton@fr.com)
FISH & RICHARDSON P.C.
111 Congress Avenue, Suite 810
Austin, Texas 78701
Telephone: (512) 472-5070
Facsimile: (512) 320-8935

ADR

RICHARD W. WIEKING
CLERK, U.S. DISTRICT COURT
NORTHERN DISTRICT OF CALIFORNIA
SAN JOSE

Attorneys for Plaintiff
MARVELL SEMICONDUCTOR, INC.

UNITED STATES DISTRICT COURT
NORTHERN DISTRICT OF CALIFORNIA

C07 05626 WDB

CV 07-570

MARVELL SEMICONDUCTOR, INC., a
California corporation,

Plaintiff,

v.

WI-LAN, INC., a Canadian corporation,

Defendant

CASE NO.

COMPLAINT FOR DECLARATORY
RELIEF;

DEMAND FOR JURY TRIAL

ORIGINAL

COMPLAINT AND JURY DEMAND

1
2 Plaintiff Marvell Semiconductor, Inc. (“Marvell”), for its complaint against defendant Wi-
3 LAN, Inc. (“Wi-LAN”) alleges:

4 **I. THE PARTIES**

5 1. Marvell is a corporation organized under the laws of the state of California.
6 Marvell’s principal place of business is 5488 Marvell Lane, Santa Clara, California 95054.

7 2. Upon information and belief, Wi-LAN is a corporation organized under the
8 Business Corporations Act (Alberta), in Canada. Upon information and belief, Wi-LAN’s
9 principal place of business is 11 Holland Avenue, Suite 608, Ottawa, Ontario, K1Y 4S1.

10 **II. JURISDICTION AND VENUE**

11 3. This action arises under the Federal Declaratory Judgments Act, 28 U.S.C. §§ 2201
12 and 2202, and the patent laws of the United States, 35 U.S.C. § 1 *et seq.* An actual, substantial
13 and continuing justiciable controversy exists between Plaintiff and Wi-LAN that requires a
14 declaration of rights by this Court.

15 4. The Court has subject mater jurisdiction pursuant to 28 U.S.C. §§ 1331, 1337, and
16 1338.

17 5. The Court has personal jurisdiction over Wi-LAN by virtue of Wi-LAN’s
18 purposeful and repeated contacts in this district, including, *inter alia*, the dispatching of agents in
19 this district in an attempt to license U.S. Reissued Patent No. RE37,802 (“the ’802 patent”), U.S.
20 Patent No. 6,192,068 (“the ’068 patent”), and U.S. Patent No. 6,320,897 (“the ’897 patent”) to
21 Plaintiff and to other companies in this district; and Wi-LAN’s threats to enforce the ’802, ’068,
22 and ’897 patents against companies with principal places in this district.

23 6. Upon information and belief, Wi-LAN has engaged in a campaign to license the
24 ’802, ’068, and ’897 patents to a number of companies located in northern California, including
25 Marvell and others. On numerous occasions, Wi-LAN has participated in face-to-face meetings
26 with a number of said companies in northern California and demanded that they take a license to
27 the ’802, ’068, and ’897 patents.

28 7. Venue is proper in this judicial district pursuant to 28 U.S.C. §§ 1391 and 1400.

1 **III. FACTUAL BACKGROUND**

2 8. U.S. Reissued Patent No. RE37,802, entitled “Multicode Direct Sequence Spread
3 Spectrum,” was filed on September 10, 1998 and reissued on July 23, 2002. The ’802 was
4 reissued from U.S. Patent No. 5,555,268, which was filed on January 24, 1994 and issued on
5 September 10, 1996. The ’802 names as inventors Michel Fattouche and Hatim Zaghoul. The
6 ’802 patent is attached as Exhibit A.

7 9. U.S. Patent No. 6,192,068, entitled “Multicode Spread Spectrum Communications
8 System,” was filed on October 3, 1996 and issued on February 20, 2001. The ’068 names as
9 inventors Michel Fattouche, Hatim Zaghoul, Paul Milligan, and David Snell. The ’068 patent is
10 attached as Exhibit B.

11 10. U.S. Patent No. 6,320,897, entitled “Multicode Spread Spectrum Communications
12 System,” was filed on September 3, 1999 and issued on November 20, 2001. The ’897 patent was
13 a continuation of the application that issued as the ’068 patent. The ’897 names as inventors
14 Michel Fattouche, Hatim Zaghoul, Paul Milligan, and David Snell. The ’897 patent is attached as
15 Exhibit C.

16 **A. Wi-LAN Demands that Marvell License the ’802, ’068, and ’897**
17 **Patents**

18 11. On or about December 15, 2006, Mr. William Middleton, Vice President, General
19 Counsel & Secretary of Wi-LAN, sent an email to Mr. Matthew Gloss at Marvell identifying the
20 ’802, ’068, and ’897 patents and asserting that the patents covered Marvell’s PxA90x
21 communications processor integrated circuit family.

22 12. On or about December 21, 2006, Mr. Middleton reiterated in a letter to Mr. Gloss
23 Wi-LAN’s assertion that the manufacture and sale of the identified Marvell products infringed the
24 ’802, ’068, and ’897 patents and that the products “require a license” to the these patents.

25 13. On or about December 29, 2006, Mr. Michael Molano of Mayer, Brown, Rowe &
26 Maw LLP, outside counsel to Marvell, responded by letter to Mr. Middleton’s communications,
27 and requested that Wi-LAN provide Marvell with infringement claim charts and the file histories
28 for the ’802, ’068, and ’897 patents. Wi-LAN never responded to Mr. Molano’s letter.

1 32. Plaintiff denies Wi-LAN's allegation with respect to infringement by Plaintiff or
2 Plaintiff's respective customers. Neither Plaintiff nor its respective customers directly infringe,
3 either literally or under the doctrine of equivalents, or induce or contribute to the infringement of,
4 any valid claim of the '068 patent.

5 33. Accordingly, there exists an actual, justiciable controversy between Plaintiff and
6 Wi-LAN relating to whether Plaintiff or its respective customers infringe the claims of the '068
7 patent.

8 34. Plaintiff desires and requests a judicial determination and declaration of the
9 respective rights and duties of the parties based on the disputes recited in this complaint.

10 **THIRD COUNT**

11 **DECLARATORY JUDGMENT – NONINFRINGEMENT OF THE '897 PATENT**

12 35. Plaintiff incorporates by reference the allegations in paragraphs 1 through 34,
13 inclusive.

14 36. This is an action for declaratory judgment of noninfringement of any and all valid
15 claims of the '897 patent.

16 37. Plaintiff has an objectively reasonable apprehension that Wi-LAN will bring a
17 patent infringement action on the '897 patent against Plaintiff and/or Plaintiff's respective
18 customers.

19 38. Wi-LAN has alleged that it "holds all rights and interest in the '897 patent."

20 39. Wi-LAN has alleged and continues to allege that Plaintiff has directly infringed,
21 and induced and/or contributed to the infringement of the '897 patent.

22 40. Plaintiff denies Wi-LAN's allegation with respect to infringement by it or its
23 respective customers. Neither Plaintiff nor its respective customers directly infringe, either
24 literally or under the doctrine of equivalents, or induce or contribute to the infringement of, any
25 valid claim of the '897 patent.

26 41. Accordingly, there exists an actual, justiciable controversy between Plaintiff and
27 Wi-LAN relating to whether Plaintiff or its respective customers infringe the claims of the '897
28 patent.

1 42. Plaintiff desires and requests a judicial determination and declaration of the
2 respective rights and duties of the parties based on the disputes recited in this complaint.

3 **FOURTH COUNT**

4 **DECLARATORY JUDGMENT – INVALIDITY OF THE '802 PATENT**

5 43. Plaintiff incorporates by reference the allegations in paragraphs 1 through 42,
6 inclusive.

7 44. This is an action for declaratory judgment of invalidity of any and all claims of the
8 '802 patent.

9 45. Plaintiff has an objectively reasonable apprehension that Wi-LAN will bring a
10 patent infringement action on the '802 patent against Plaintiff and/or Plaintiff's customers.

11 46. The claims of the '802 patent are invalid because they fail to comply with the
12 conditions and requirements for patentability set forth in 35 U.S.C. § 1 et seq., including but not
13 limited to 35 U.S.C. §§ 101, 102, 103, 112, 115, 116, 118, 132, and 256.

14 47. Accordingly, there exists an actual, justiciable controversy between Plaintiff and
15 Wi-LAN relating to whether the claims of the '802 patent are invalid.

16 48. Plaintiff desires and requests a judicial determination and declaration of the
17 respective rights and duties of the parties based on the disputes recited in this complaint.

18 **FIFTH COUNT**

19 **DECLARATORY JUDGMENT – INVALIDITY OF THE '068 PATENT**

20 49. Plaintiff incorporates by reference the allegations in paragraphs 1 through 48,
21 inclusive.

22 50. This is an action for declaratory judgment of invalidity of any and all claims of the
23 '068 patent.

24 51. Plaintiff has an objectively reasonable apprehension that Wi-LAN will bring a
25 patent infringement action on the '068 patent against Plaintiff and/or Plaintiff's customers.

26 52. The claims of the '068 patent are invalid because they fail to comply with the
27 conditions and requirements for patentability set forth in 35 U.S.C. § 1 et seq., including but not
28 limited to 35 U.S.C. §§ 101, 102, 103, 112, 115, 116, 118, 132, and 256.

1 53. Accordingly, there exists an actual, justiciable controversy between Plaintiff and
2 Wi-LAN relating to whether the claims of the '068 patent are invalid.

3 54. Plaintiff desires and requests a judicial determination and declaration of the
4 respective rights and duties of the parties based on the disputes recited in this complaint.

5 **SIXTH COUNT**

6 **DECLARATORY JUDGMENT – INVALIDITY OF THE '897 PATENT**

7 55. Plaintiff incorporates by reference the allegations in paragraphs 1 through 54,
8 inclusive.

9 56. This is an action for declaratory judgment of invalidity of any and all claims of the
10 '897 patent.

11 57. Plaintiff has an objectively reasonable apprehension that Wi-LAN will bring a
12 patent infringement action on the '897 patent against Plaintiff and/or Plaintiff's customers.

13 58. The claims of the '897 patent are invalid because they fail to comply with the
14 conditions and requirements for patentability set forth in 35 U.S.C. § 1 et seq., including but not
15 limited to 35 U.S.C. §§ 101, 102, 103, 112, 115, 116, 118, 132, and 256.

16 59. Accordingly, there exists an actual, justiciable controversy between Plaintiff and
17 Wi-LAN relating to whether the claims of the '897 patent are invalid.

18 60. Plaintiff desires and requests a judicial determination and declaration of the
19 respective rights and duties of the parties based on the disputes recited in this complaint.

20 **SEVENTH COUNT**

21 **DECLARATORY JUDGMENT – PATENT MISUSE ('802 PATENT)**

22 61. Plaintiff incorporates by reference the allegations in paragraphs 1 through 60,
23 inclusive.

24 62. The '802 patent is unenforceable for patent misuse, due to Wi-LAN's continuing
25 unlawful attempts to enforce the '802 patent as alleged in this complaint.

26 63. On information and belief, despite Wi-LAN's knowledge and awareness that the
27 '802 patent is invalid and unenforceable, as alleged herein, Wi-LAN has attempted and continues
28

1 to attempt to improperly obtain the economic advantage of injunctive relief and/or monetary
2 damages against Plaintiff and its respective customers.

3 64. Accordingly, there exists an actual, justiciable controversy between Plaintiff and
4 Wi-LAN concerning whether the claims of the '802 patent are unenforceable due to patent misuse.

5 65. Plaintiff desires and requests a judicial determination and declaration of the
6 respective rights and duties of the parties based on the disputes recited in this complaint.

7 **EIGHTH COUNT**

8 **DECLARATORY JUDGMENT – PATENT MISUSE ('068 PATENT)**

9 66. Plaintiff incorporates by reference the allegations in paragraphs 1 through 65,
10 inclusive.

11 67. The '068 patent is unenforceable for patent misuse, due to Wi-LAN's continuing
12 unlawful attempts to enforce the '068 patent as alleged in this complaint.

13 68. On information and belief, despite Wi-LAN's knowledge and awareness that the
14 '068 patent is invalid and unenforceable, as alleged herein, Wi-LAN has attempted and continues
15 to attempt to improperly obtain the economic advantage of injunctive relief and/or monetary
16 damages against Plaintiff and its respective customers.

17 69. Accordingly, there exists an actual, justiciable controversy between Plaintiff and
18 Wi-LAN concerning whether the claims of the '068 patent are unenforceable due to patent misuse.

19 70. Plaintiff desires and requests a judicial determination and declaration of the
20 respective rights and duties of the parties based on the disputes recited in this complaint.

21 **NINTH COUNT**

22 **DECLARATORY JUDGMENT – PATENT MISUSE ('897 PATENT)**

23 71. Plaintiff incorporates by reference the allegations in paragraphs 1 through 70,
24 inclusive.

25 72. The '897 patent is unenforceable for patent misuse, due to Wi-LAN's continuing
26 unlawful attempts to enforce the '897 patent as alleged in this complaint.

27 73. On information and belief, despite Wi-LAN's knowledge and awareness that the
28 '897 patent is invalid and unenforceable, as alleged herein, Wi-LAN has attempted and continues

1 to attempt to improperly obtain the economic advantage of injunctive relief and/or monetary
2 damages against Plaintiff and its respective customers.

3 74. Accordingly, there exists an actual, justiciable controversy between Plaintiff and
4 Wi-LAN concerning whether the claims of the '897 patent are unenforceable due to patent misuse.

5 75. Plaintiff desires and requests a judicial determination and declaration of the
6 respective rights and duties of the parties based on the disputes recited in this complaint.

7 **PRAYER FOR RELIEF**

8 A. A judgment declaring that the Plaintiff has not infringed and does not infringe in
9 any manner any valid claim of the '802 patent;

10 B. A judgment declaring that the Plaintiff has not infringed and does not infringe in
11 any manner any valid claim of the '068 patent;

12 C. A judgment declaring that the Plaintiff has not infringed and does not infringe in
13 any manner any valid claim of the '897 patent;

14 D. A judgment declaring that each claim of the '802 patent is invalid;

15 E. A judgment declaring that each claim of the '068 patent is invalid;

16 F. A judgment declaring that each claim of the '897 patent is invalid;

17 G. A judgment declaring that the '802 patent is unenforceable and therefore without
18 any force or effect against Plaintiff, its respective officers, agents, employees and customers;

19 H. A judgment declaring that the '068 patent is unenforceable and therefore without
20 any force or effect against Plaintiff, its respective officers, agents, employees and customers;

21 I. A judgment declaring that the '897 patent is unenforceable and therefore without
22 any force or effect against Plaintiff, its respective officers, agents, employees and customers;

23 J. A judgment determining this to be an "exceptional" case within the meaning of 35
24 U.S.C. § 285, entitling Plaintiff to an award of its reasonable attorneys' fees, expenses, and costs
25 in this action; and

26 K. For such other and further relief, in law or in equity, as this Court deems just.
27
28

JURY TRIAL DEMAND

Plaintiff demands a trial by jury as to all issues and causes of action so triable herein,
pursuant to Federal Rule of Civil Procedure 38.

Dated: November 5, 2007

FISH & RICHARDSON P.C.

By: 
David M. Barkan

Attorneys for Plaintiff
MARVELL SEMICONDUCTOR, INC.

50446887.doc

1
2
3
4
5
6
7
8
9
10
11
12
13
14
15
16
17
18
19
20
21
22
23
24
25
26
27
28

EXHIBIT A



US00RE37802E

(19) **United States**
 (12) **Reissued Patent**
Fattouche et al.

(10) **Patent Number: US RE37,802 E**
 (45) **Date of Reissued Patent: Jul. 23, 2002**

(54) **MULTICODE DIRECT SEQUENCE SPREAD SPECTRUM**

FOREIGN PATENT DOCUMENTS

(75) Inventors: **Michel T. Fattouche; Hatim Zaghoul,**
 both of Calgary (CA)

CA	1 203 576	8/1977
EP	0 562 868 A2	9/1993
EP	0 567 771 A2	11/1993
GB	2 146 875 A	4/1985

(73) Assignee: **Wi-LAN Inc.,** Calgary (CA)

OTHER PUBLICATIONS

(21) Appl. No.: **09/151,604**

(22) Filed: **Sep. 10, 1998**

Jinkang Zhu, Hongbin Zhang, Yucong Gu, Principle and Performance of Variable Rate Multi-code CDMA Method, 1995 Fourth IEEE International Conference on Universal Personal Communications. Record. Gateway to the 21st Century (Cat. No. 95TH8128). IEEE, pp. 256-259, New York, NY, USA, 1995.

Related U.S. Patent Documents

Reissue of:

(64) Patent No.: **5,555,268**
 Issued: **Sep. 10, 1996**
 Appl. No.: **08/186,784**
 Filed: **Jan. 24, 1994**

(List continued on next page.)

(51) **Int. Cl.⁷ H04B 1/707; H04B 1/69**

(52) **U.S. Cl. 375/141; 370/209; 375/146;**
 375/147; 380/34

(58) **Field of Search 375/200, 201,**
 375/202, 203, 204, 206, 207, 208, 209,
 210, 130-153, 271, 279, 280, 322, 329,
 332; 380/34, 46; 370/203, 204, 205, 206,
 207, 208, 209, 210, 211; 364/717.01, 717.02,
 717.03, 717.04, 717.05, 717.06, 717.07;
 331/78; 714/746, 752, 778, 781, 782

Primary Examiner—Bernarr E. Gregory

(74) *Attorney, Agent, or Firm*—Christensen O'Connor Johnson Kindness PLLC

(57) **ABSTRACT**

In this patent, we present MultiCode Direct Sequence Spread Spectrum (MC-DSSS) which is a modulation scheme that assigns up to N DSSS codes to an individual user where N is the number of chips per DSSS code. When viewed as DSSS, MC-DSSS requires up to N correlators (or equivalently up to N Matched Filters) at the receiver with a complexity of the order of N² operations. In addition, a non ideal communication channel can cause InterCode Interference (ICI), i.e., interference between the N DSSS codes. In this patent, we introduce new DSSS codes, which we refer to as the "MC" codes. Such codes allow the information in a MC-DSSS signal to be decoded in a sequence of low complexity parallel operations which reduce the ICI. In addition to low complexity decoding and reduced ICI. MC-DSSS using the MC codes has the following advantages: (1) it does not require the stringent synchronization DSSS requires, (2) it does not require the stringent carrier recovery DSSS requires and (3) it is spectrally efficient.

(56) **References Cited**

U.S. PATENT DOCUMENTS

3,485,949 A	12/1969	De Haas
3,789,149 A	1/1974	Clark
3,956,619 A	5/1976	Mundy et al.
3,987,374 A	10/1976	Jones, Jr.
4,092,491 A	5/1978	Frazer
4,164,628 A	8/1979	Ward et al.
4,306,308 A	12/1981	Nossen
4,457,004 A	6/1984	Gersho et al.
4,520,490 A	5/1985	Wei
4,601,005 A	7/1986	Kilvington
4,601,045 A	7/1986	Lubarsky
4,615,040 A	9/1986	Mojoli et al.
4,623,980 A	11/1986	Vary

(List continued on next page.)

40 Claims, 20 Drawing Sheets

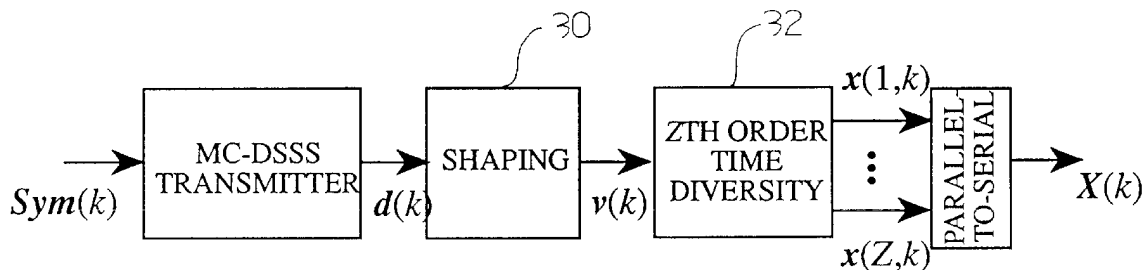

US RE37,802 E

Page 2

U.S. PATENT DOCUMENTS

4,641,318	A	2/1987	Addeo	
4,660,215	A	4/1987	Horiike et al.	
4,694,466	A	9/1987	Kadin	
4,713,817	A	12/1987	Wei	
4,731,816	A	3/1988	Hughes-Hartogs	
4,799,214	A	1/1989	Kaku	
4,809,299	A	2/1989	Ho	
4,829,540	A	5/1989	Waggener, Sr. et al.	
4,868,874	A	9/1989	Takatori et al.	
4,881,241	A	11/1989	Pommier et al.	
4,893,266	A	1/1990	Deem	
4,901,307	A	2/1990	Gilhousen et al.	
4,914,699	A	4/1990	Dunn et al.	
4,928,310	A	* 5/1990	Goutzoulis et al.	380/46
4,933,952	A	* 6/1990	Albrieux et al.	375/200
4,944,009	A	* 7/1990	Micali et al.	380/46
4,979,183	A	12/1990	Cowart	
5,029,180	A	7/1991	Cowart	
5,034,911	A	7/1991	Rachels	
5,063,560	A	11/1991	Yerbury et al.	
5,063,574	A	11/1991	Moose	
5,073,899	A	12/1991	Collier et al.	
5,089,982	A	2/1992	Gran et al.	
5,103,459	A	4/1992	Gilhousen et al.	
5,128,964	A	7/1992	Mallory	
5,134,464	A	7/1992	Basile et al.	
5,151,919	A	9/1992	Dent	
5,157,686	A	10/1992	Omura et al.	
5,166,924	A	11/1992	Moose	
5,166,951	A	11/1992	Schilling	
5,193,094	A	3/1993	Viterbi	
5,210,770	A	5/1993	Rice	
5,228,025	A	7/1993	Le Floch et al.	
5,235,614	A	* 8/1993	Bruckert et al.	370/209
5,268,926	A	12/1993	Sebilet	
5,274,629	A	12/1993	Helard et al.	
5,278,844	A	* 1/1994	Murphy et al.	714/778
5,285,474	A	2/1994	Chow et al.	
5,291,515	A	3/1994	Uchida et al.	
5,307,376	A	4/1994	Castelain et al.	
5,309,474	A	5/1994	Gilhousen et al.	
5,345,440	A	9/1994	Gledhill et al.	
5,357,541	A	10/1994	Cowart	
5,373,502	A	12/1994	Turban	
5,375,140	A	12/1994	Bustamante et al.	
5,414,734	A	5/1995	Marchetto et al.	
5,416,797	A	5/1995	Gilhousen et al.	
5,442,625	A	8/1995	Gitlin et al.	
5,467,367	A	11/1995	Izumi et al.	
5,469,469	A	11/1995	Haines	
5,479,447	A	12/1995	Chow et al.	
5,487,069	A	1/1996	O'Sullivan et al.	
5,550,812	A	8/1996	Philips	
5,596,601	A	1/1997	Bar-David	
5,615,209	A	3/1997	Bottomley	
5,623,511	A	4/1997	Bar-David et al.	
5,715,236	A	2/1998	Gilhousen et al.	
5,960,032	A	9/1999	Letaief et al.	

OTHER PUBLICATIONS

Proakis, J.G., *Digital Communication*, 2d ed., 1991, Chap. 8, "Spread Spectrum Signals for Digital Communications," pp. 800-891.

Gledhill, J.J., et al., "The Transmission of Digital Television In The UHF Band Using Orthogonal Frequency Division Multiplexing," pp. 175-180, No Date.

Duch, Krzysztof M., "Baseband Signal Processing," *Network Magazine*, pp. 39-43; Nov. 1991.

Ananasso, Fulvio, et al., "Clock Synchronous Multicarrier Demodulator For Multi-Frequency TDMA Communication Satellites," pp. 1059-1063; 1990.

Saito, Masafumi, et al., "A Digital Modulation Method For Terrestrial Digital TV Broadcasting Using Trellis Coded OFDM And Its Performance," pp. 1694-1698; Globecom '92 Conference; 1992.

Alard, M., et al., "A New System Of Sound Broadcasting To Mobile Receivers," pp. 416-420; 1988.

Chow, Jacky S., et al., "A Discrete Multitone Tranceiver System for HDSL Applications," pp. 895-908; "IEEE Journal on Selected Areas In Communications"; Aug. 1991.

Chow, Peter S., et al., "Performance Evaluation of a Multichannel Transceiver System for ADSL and VHDSL Services," pp. 909-919; IEEE Journal on Selected Areas in Communications; Aug. 1991.

Pupolin, Silvano, et al., "Performance Analysis Of Digital Radio Links With Nonlinear Transmit Amplifier And Data Predistorter With Memory," pp. 9.6.1-9.6.5; 1989.

Bingham, J.A.C.; "Multicarrier Modulation for Data Transmission: An Idea Whose Time Has Come", *IEEE Communications Magazine*, pp. 5-14, May 1990.

Spracklen, C.T. and C. Smythe, "The Application of Code Division Multiplexing Techniques to Local Area Networks," pp. 767-770, May 1987.

Scott L. Miller and Weerakhan Tantiphaibontana, Code Division Multiplexing—Efficient Modulation for High Data Rate Transmission Over Wireless Channels, Proceedings of 2000 IEEE International Conference on Communications, pp. 1487-1491.

Shigenobu Sasaki, Jinkang Zhu, and Gen Marubayashi, Performance of Parallel Combinatory Spread Spectrum Multiple Access Communication Systems, Proceedings of 1991 IEEE International Symposium on Personal, Indoor and Mobile Radio Communications (PIMRC), pp. 204-208.

Jinkang Zhu and Gen Marubayashi, Properties and Application of Parallel Combinatory SS Communication System, IEEE Second International Symposium on Spread Spectrum Techniques and Applications (ISSSTA '92), Yokohama, Japan, pp. 227-230, Nov. 29-Dec. 2, 1992.

K. Ben Letaief, J. C-I Chuang, and R.D. Murch, Multicode High-Speed Transmission for Wireless Mobile Communications, Proceedings of the 1995 IEEE Global Telecommunications Conference GLOBEOM'95, Singapore, pp. 1835-1839, Nov. 14-16, 1995.

Reduction of Multipath Fading Effects in Single Variable Modulations, M.A. Poletti and R.G. Vaughan, ISSPA 90 Signal Processing Theories, Implementations and Applications, Gold Coast, Australia Aug. 27-31, 1990, 672-676.

OFDM for Data Communication over Mobile Radio FM Channels; Part I: Analysis and Experimental Results, E.F. Casas and C. Leung, IEEE Transactions on Communications, vol. 39, No. 5, May 1991.

US RE37,802 E

Page 3

- OFDM for Data Communication over Mobile Radio FM Radio Channels; Part II: Performance Improvement*, E.F. Casas and C. Leung, Dept. of Electrical Engineering, University of British Columbia, Vancouver, BC, Canada, 1991.
- Performance of an RCPC-Coded OFDM-Based Digital Audio Broadcasting (DAB) System, P. Hoher, J. Hagenauer, E. Offer, Ch. Rapp, H. Schulze, Globecom '91, CH 2980-1/91/0000-0040, pp. 0040-0046.
- The Multitone Channel, Irving Kalet, IEEE Transactions on Communications, vol. 37, No. 2, Feb. 1989.
- Optimized Decision Feedback Equalization Versus Optimized Orthogonal Frequency Division Multiplexing for High-Speed Data Transmission Over the Local Cable Network, Nikolaos A. Zervos and Irving Kalet, CH2655-9/89/0000-1989 IEEE, pp. 1080-1085.
- Advanced Groupband Data Modem Using Orthogonally Multiplexed QAM Technique, Botaro Hirosaki, Satoshi Hasegawa and Akio Sabato, IEEE Transactions on Communications, vol. Com-34, No. 6, Jun. 1996, pp. 587-592.
- A 19.2 kbps Voiceband Data Modem Based on Orthogonally Multiplexed QAM Techniques, B. Hirosaki, A. Yoshida, O. Tanaka, S. Hasegawa, K. Inoue and K. Watanabe, CH2175-8/85/0000-0661 IEEE, pp. 661-665.
- Analysis and Stimulation of a Digital Mobile Channel Using Orthogonal Frequency Division Multiplexing, Leonard J. Cimini, Jr., IEEE Transactions on Communications, vol. Comm-33, No. 7, Jul. 1985, pp. 665-675.
- An Orthogonally Multiplexed QAM System Using the Discrete Fourier Transform, Botaro Hirosaki, IEEE Transactions on Communications, vol. Com-29, No. 7, Jul. 1981, pp. 982-989.
- An Analysis of Automatic Equalizers of Orthogonally Multiplexed QAM Systems, Botaro Hirosaki, IEEE Transactions on Communications, vol. Com-28, No. 1, Jan. 1980, pp. 73-83.
- An Improved Method for Digital SSB-FDM Modulation and Demodulation, Rikio Maruta and Atsushi Tomozawa, IEEE Transactions on Communications, vol. Com-26, No. 5, May 1978, pp. 720-725.
- Data Transmission by Frequency-Division Multiplexing Using the Discrete Fourier Transform, S.B. Weinstein and Paul M. Ebert, IEEE Transactions on Communications, vol. Com-19, No. 5, Oct. 1971, pp. 628-634.
- Performance of an Efficient Parallel Data Transmission System, Burton R. Saltzberg, IEEE Transactions on Communication Technology, vol. Com-15, No. 6, Dec. 1967, pp. 805-811.
- A Theoretical Study of Performance of an Orthogonal Multiplexing Data Transmission Scheme, Robert W. Chang and Richard A. Gibby, IEEE Transactions on Communication Technology, vol. Com-16, No. 4, Aug. 1968, pp. 529-540.
- Synthesis of Band-Limited Orthogonal Signals for Multichannel Data Transmission, Robert W. Chang, The Bell System Technical Journal, Dec. 1966, pp. 1775-1796.

* cited by examiner

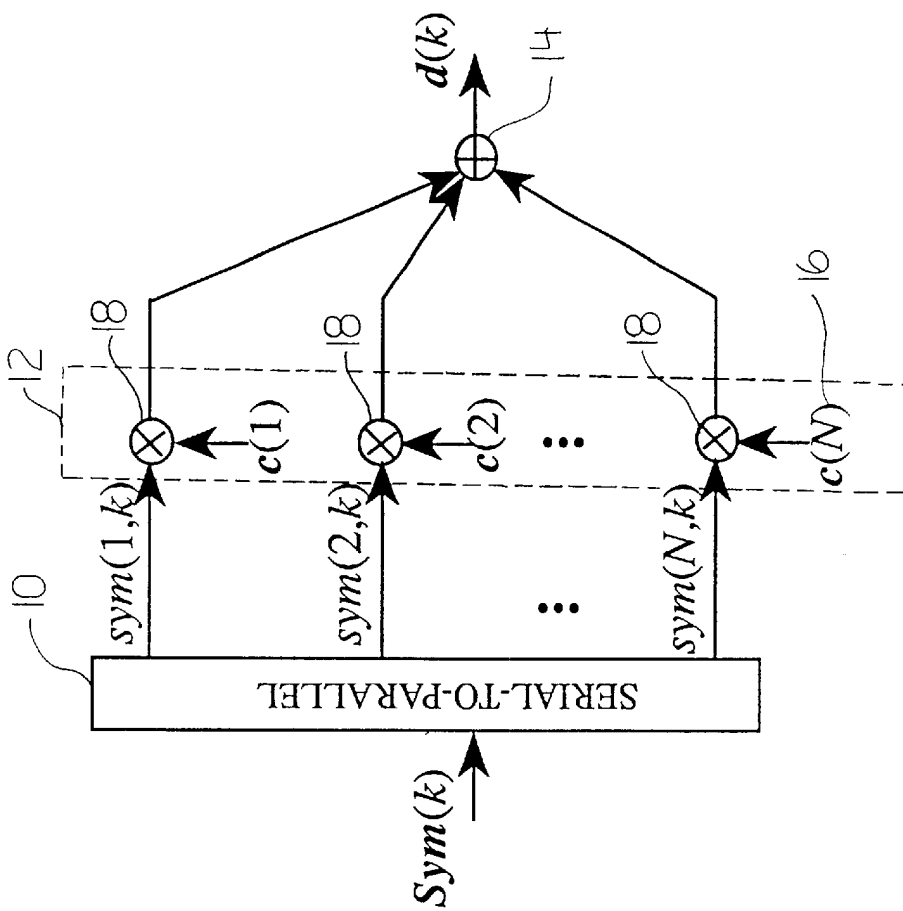

FIGURE 1

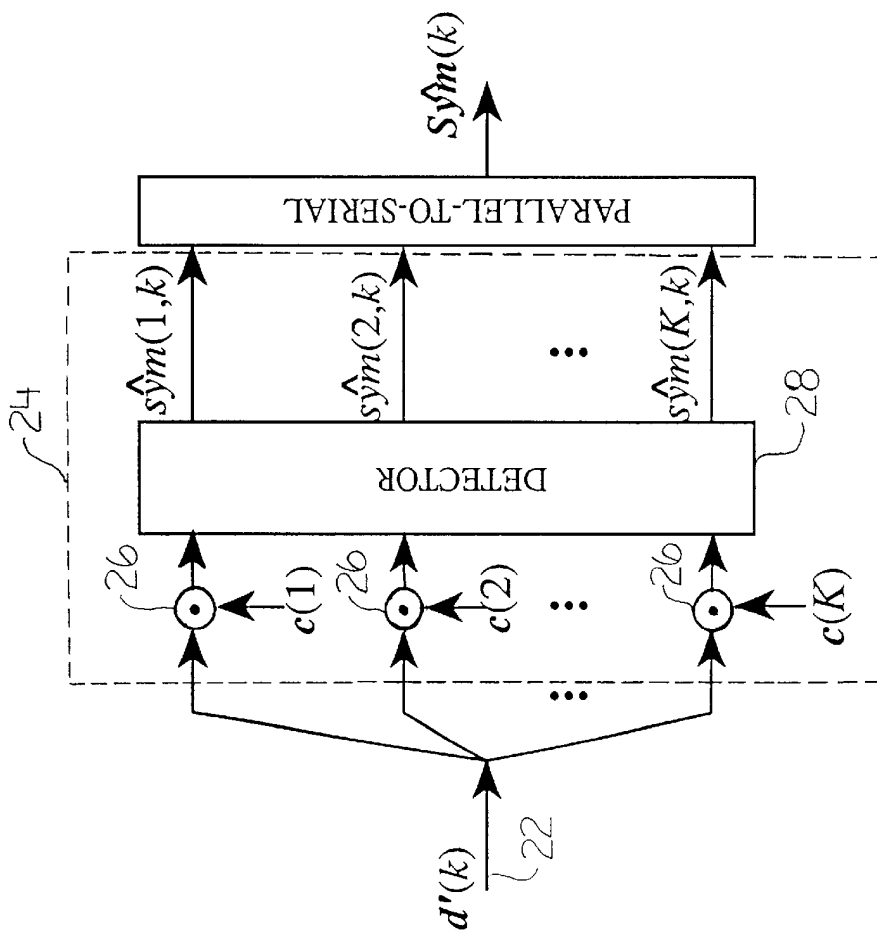

FIGURE 2

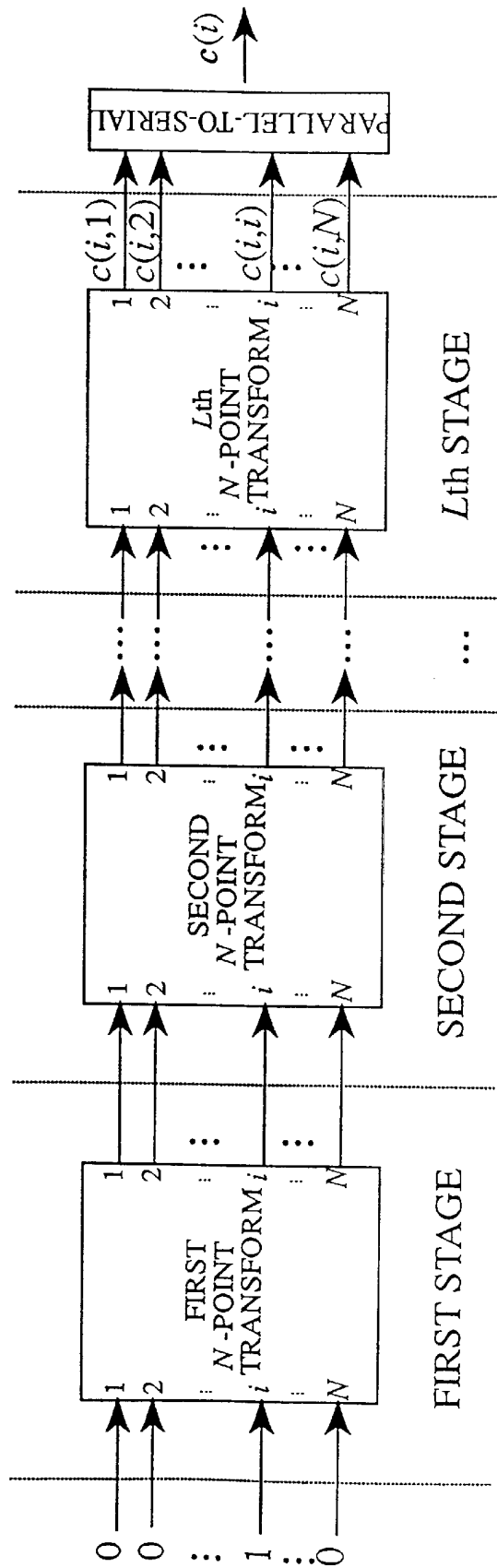

FIGURE 3

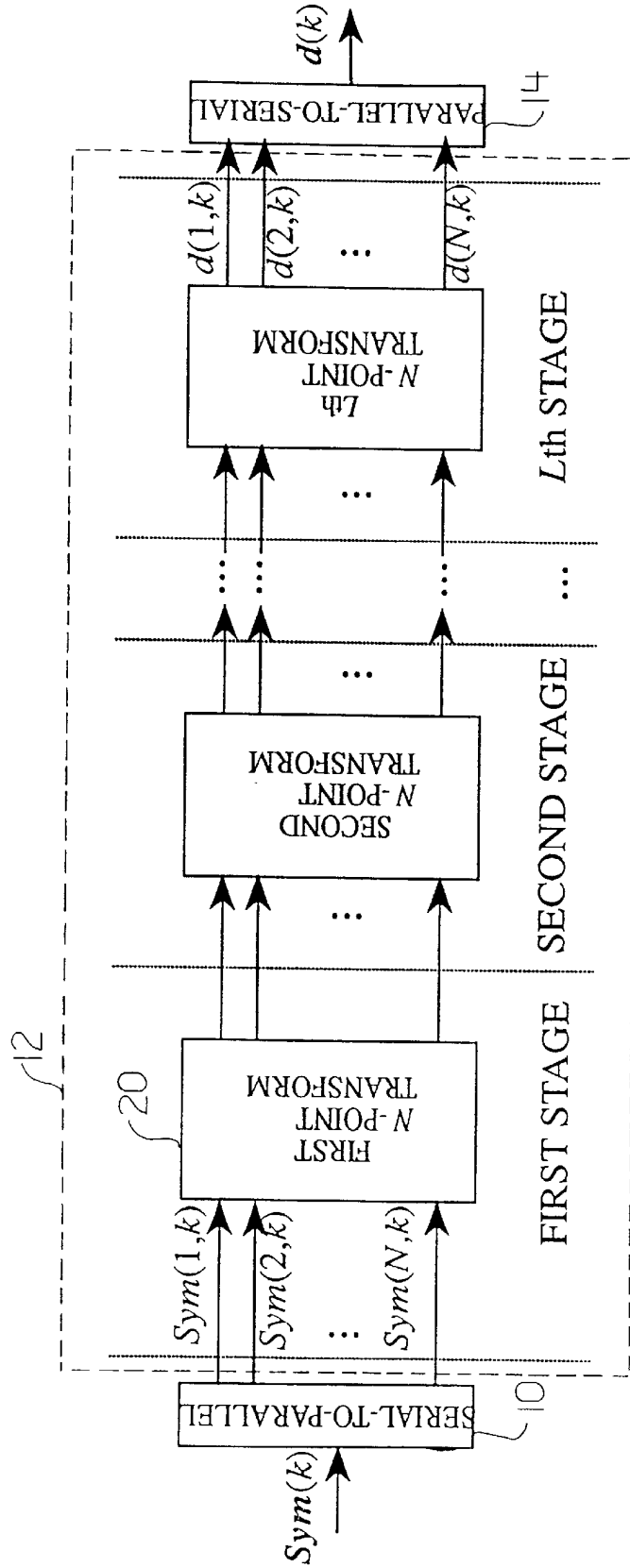

FIGURE 4

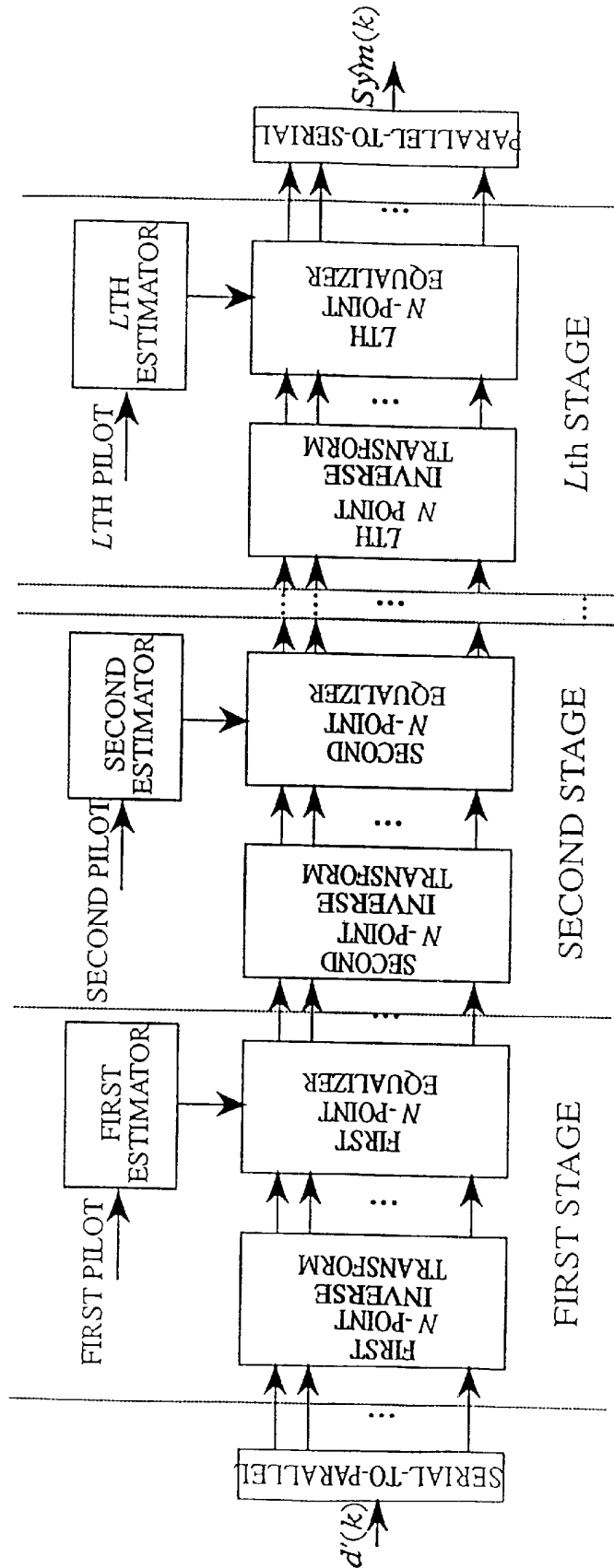

FIGURE 5

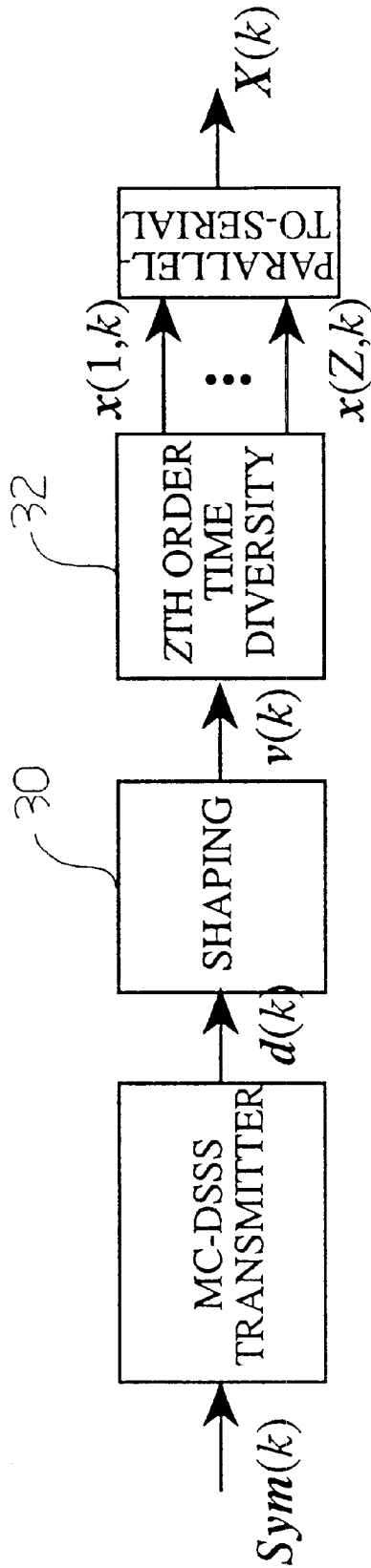

FIGURE 6

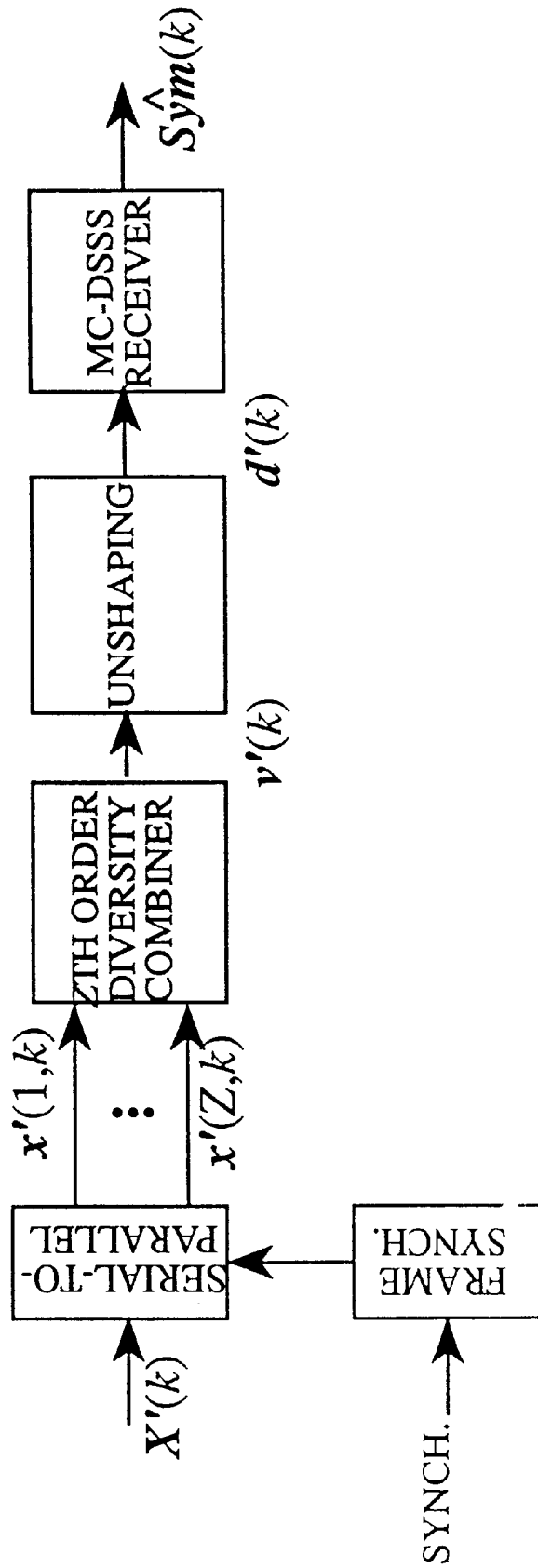

FIGURE 7

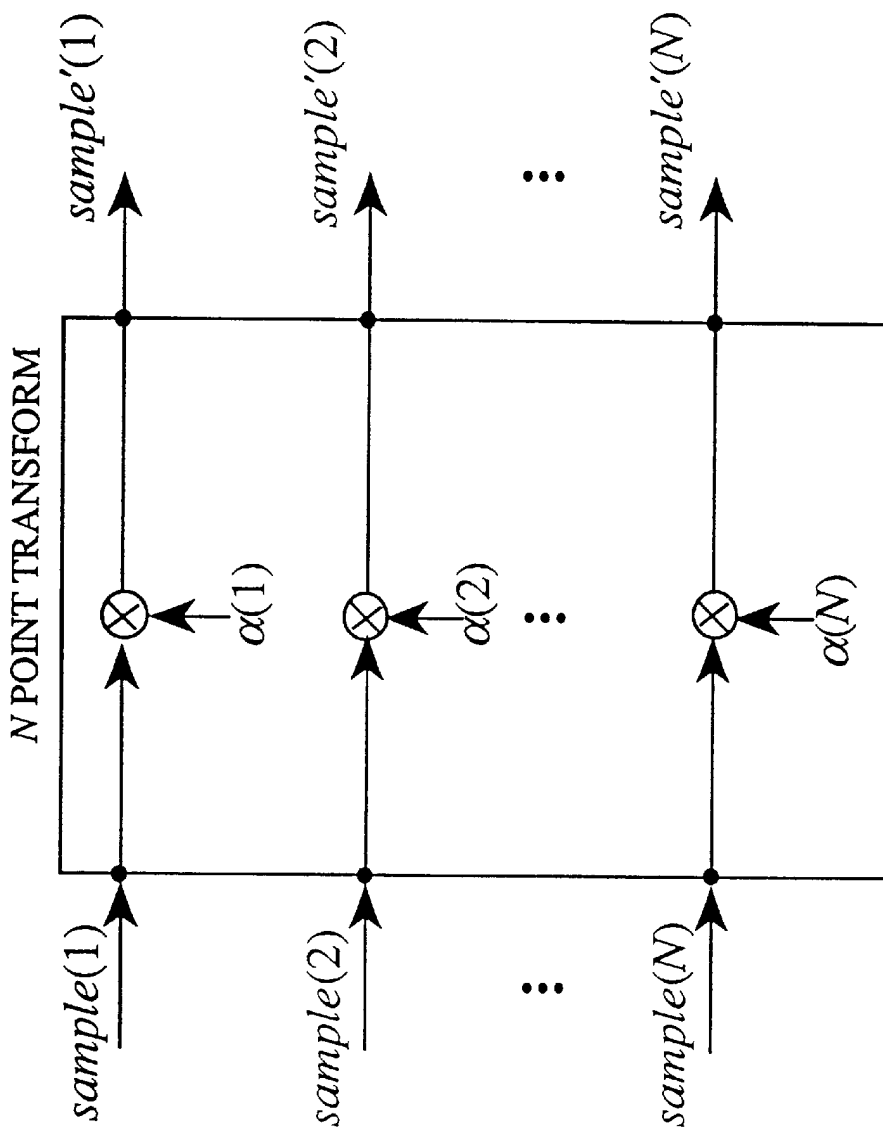

FIGURE 8

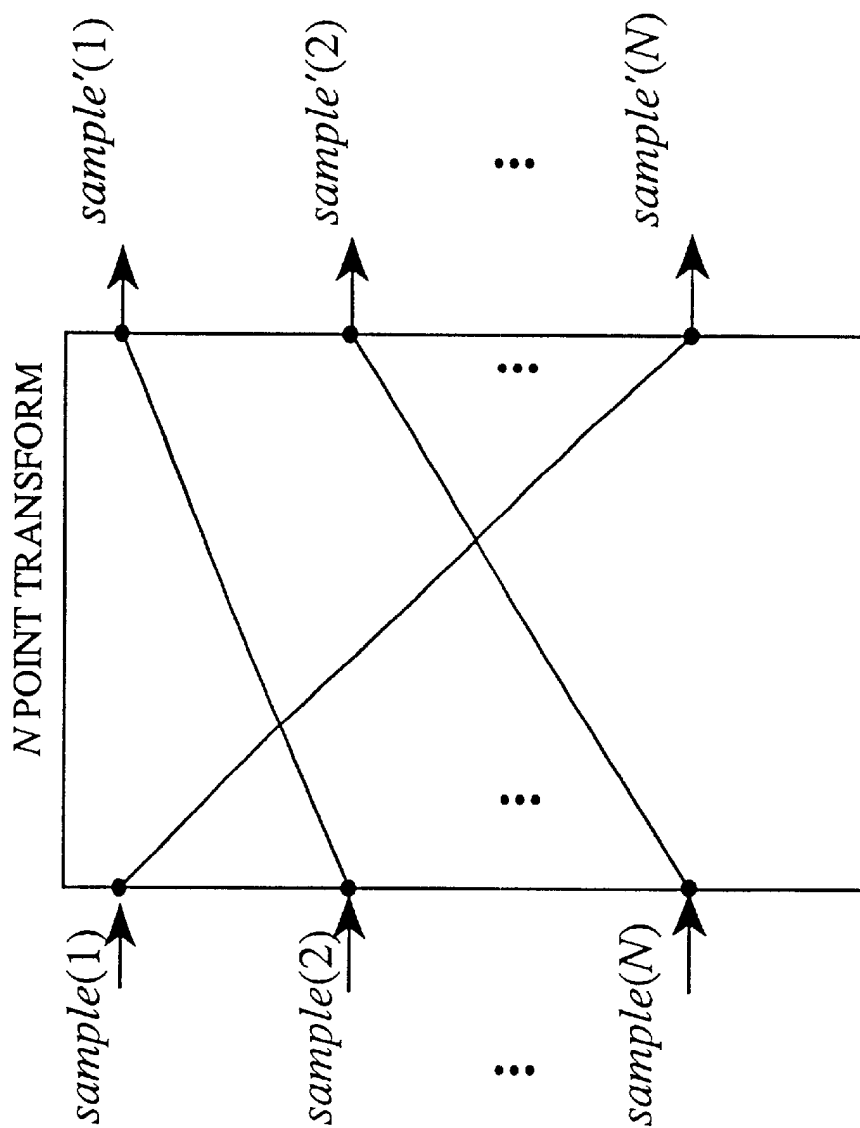

FIGURE 9

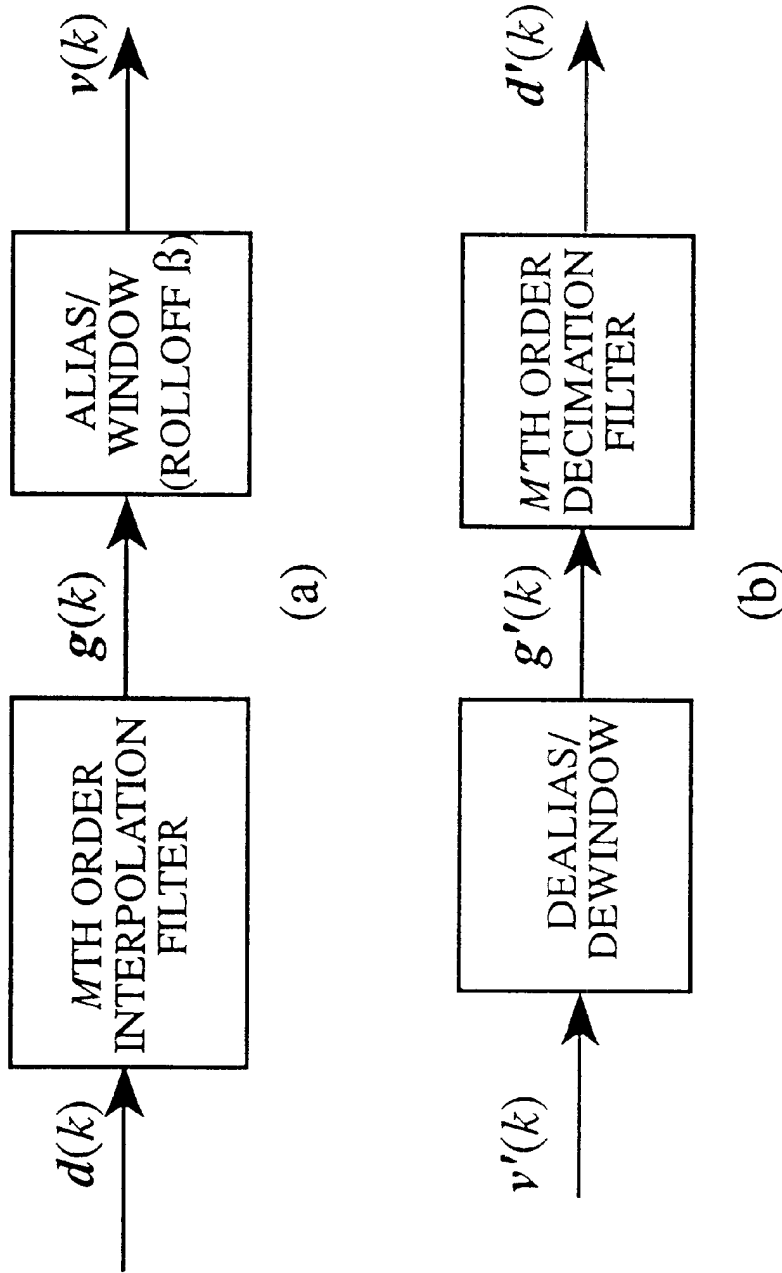

FIGURE 10

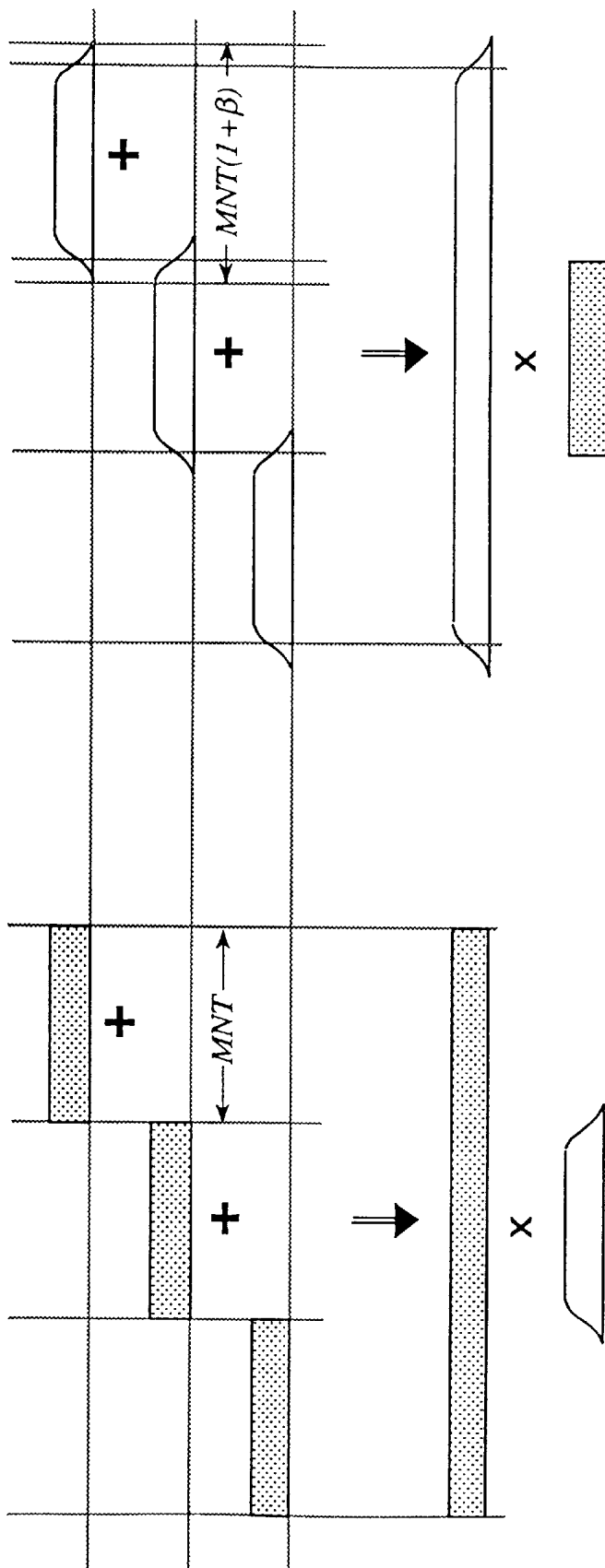

FIGURE 11

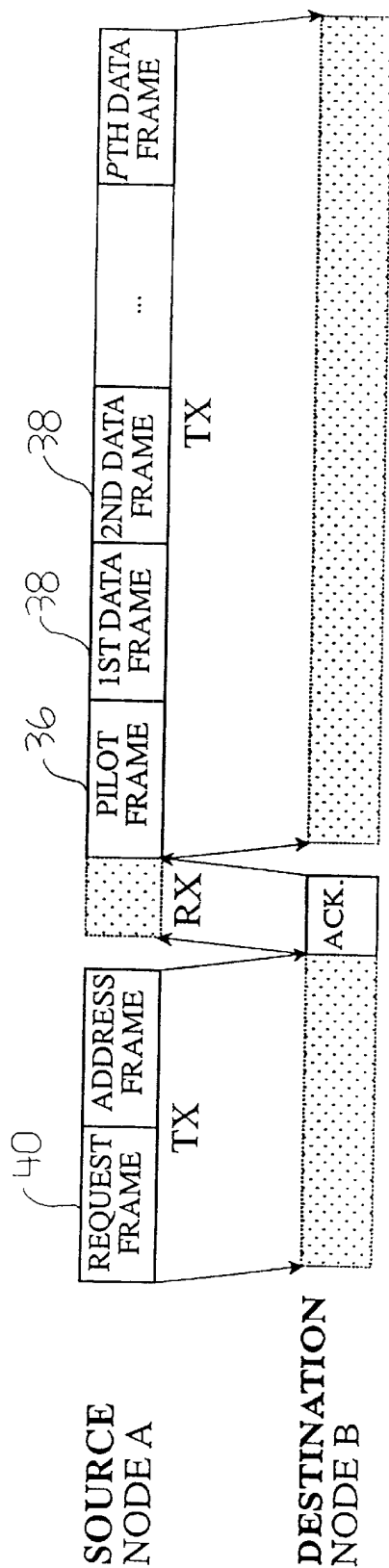

FIGURE 12

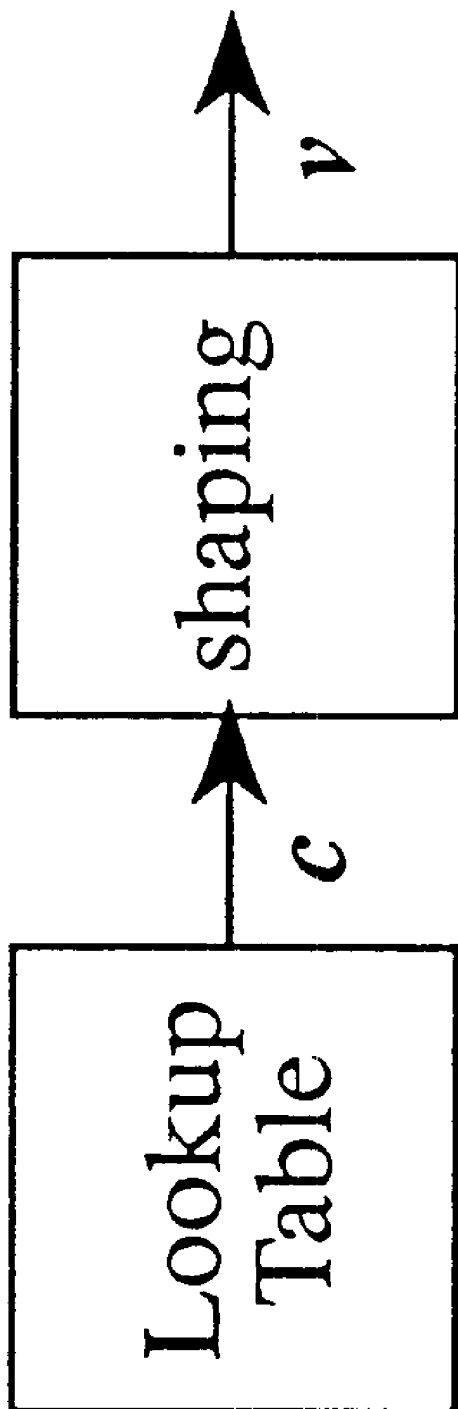

FIGURE 13

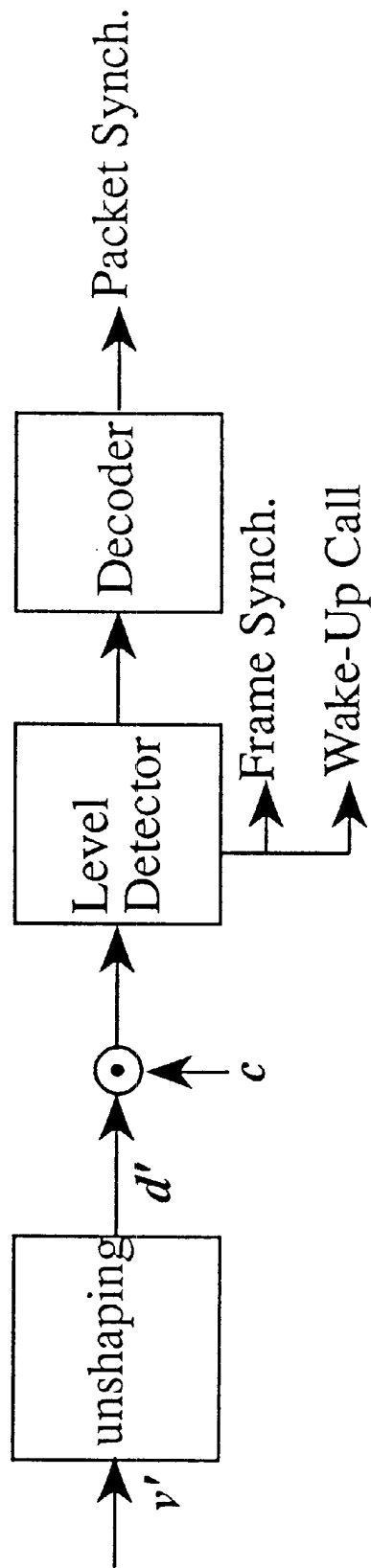

FIGURE 14

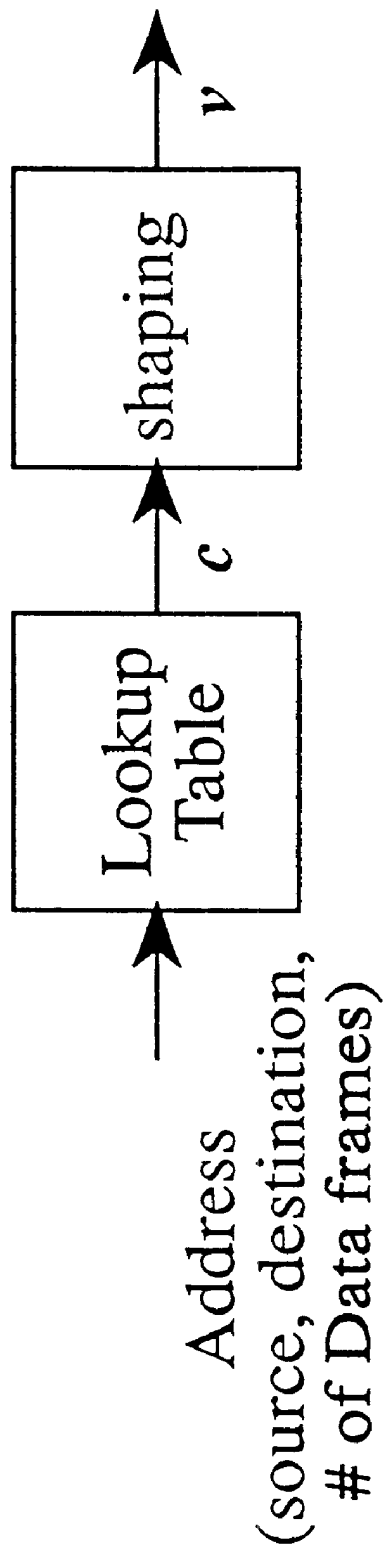

FIGURE 15

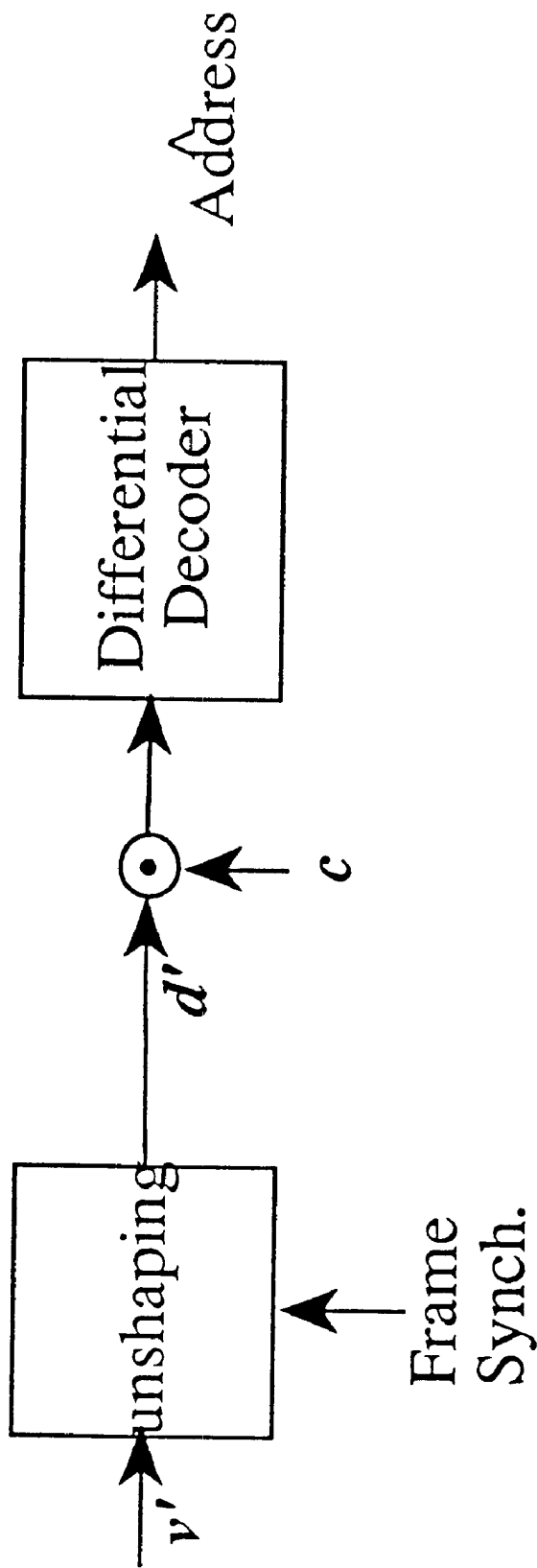

FIGURE 16

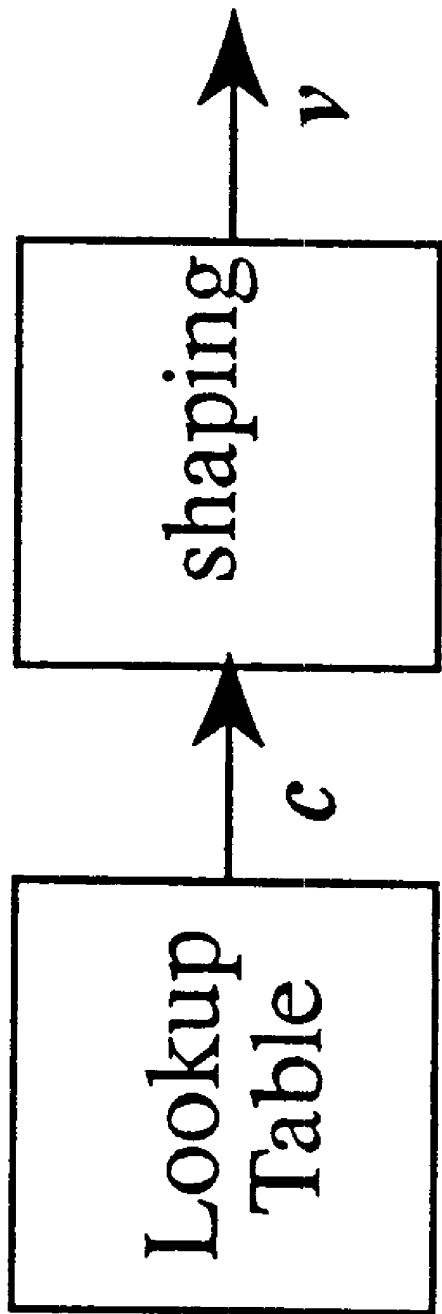

FIGURE 17

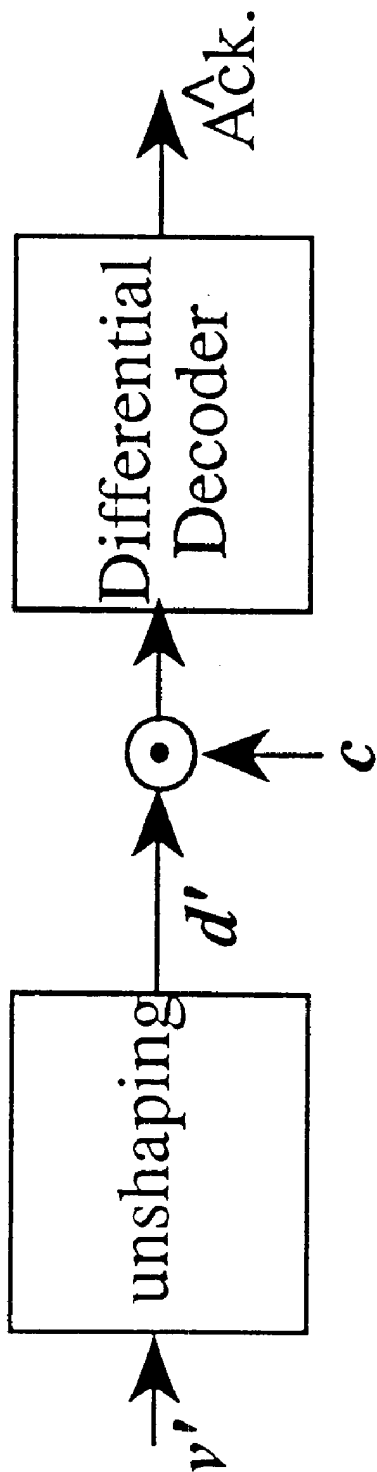

FIGURE 18

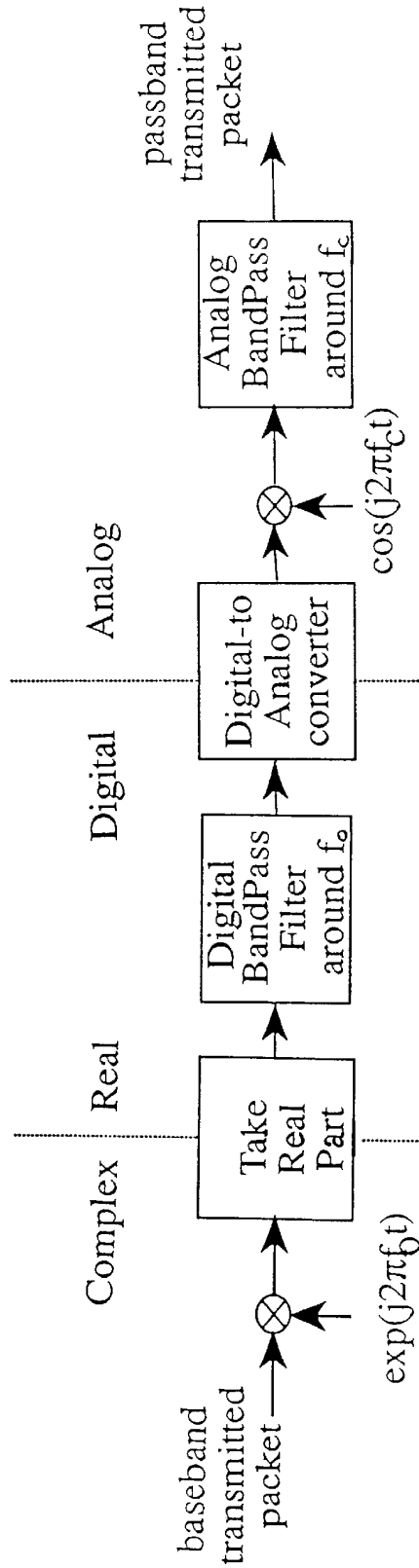

FIGURE 19

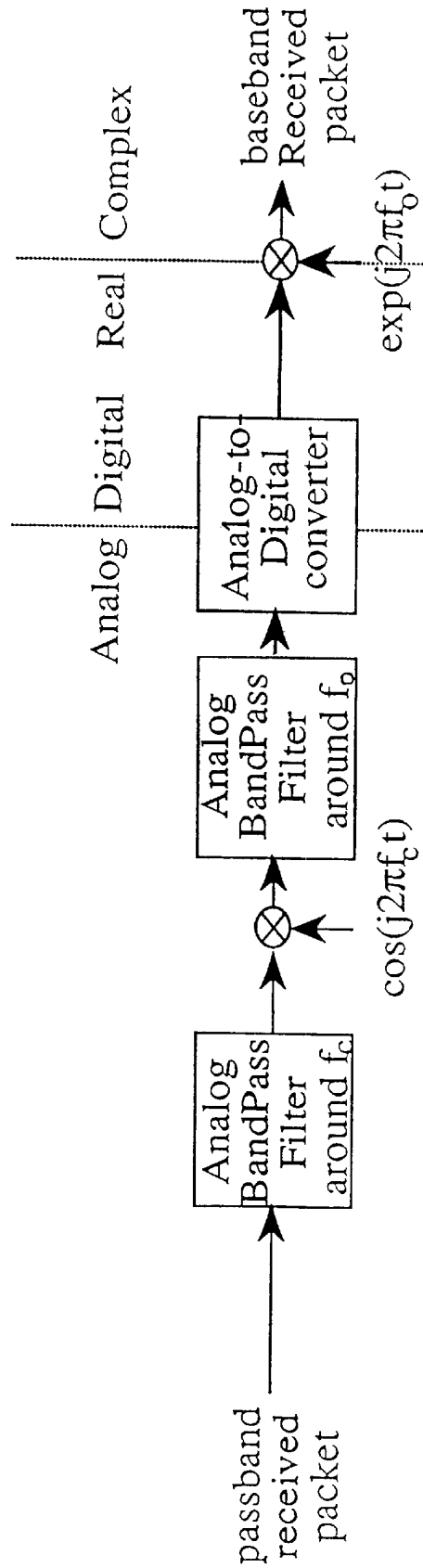

FIGURE 20

MULTICODE DIRECT SEQUENCE SPREAD SPECTRUM

Matter enclosed in heavy brackets [] appears in the original patent but forms no part of this reissue specification; matter printed in italics indicates the additions made by reissue.

This application is a REISSUE of Ser. No. 08/186,784 filed Jan. 24, 1994 is a continuation-in-part of U.S. application Ser. No. 07/861,725 filed Mar. 31, 1992, now U.S. Pat. No. 5,282,222, the benefit of the filing date of which is hereby claimed under 35 U.S.C. §120.

FIELD OF THE INVENTION

The invention deals with the field of multiple access communications using Spread Spectrum modulation. Multiple access can be classified as either random access, polling, TDMA, FDMA, CDMA or any combination thereof. Spread Spectrum can be classified as Direct Sequence, Frequency-Hopping or a combination of the two.

BACKGROUND OF THE INVENTION

Commonly used spread spectrum techniques are Direct Sequence Spread Spectrum (DSSS) and Code Division Multiple Access (CDMA) as explained in Chapter 8 of "Digital Communication" by J. G. Proakis, Second Edition, 1991, McGraw Hill, DSSS is a communication scheme in which information bits are spread over code bits (generally called chips). It is customary to use noise-like codes called pseudo random noise (PN) sequences. These PN sequences have the property that their auto-correlation is almost a delta function and their cross-correlation with other codes is almost null. The advantages of this information spreading are:

1. The transmitted signal can be buried in noise and thus has a low probability of intercept.
2. The receiver can recover the signal from interferers (such as other transmitted codes) with a jamming margin that is proportional to the spreading code length.
3. DSSS codes of duration longer than the delay spread of the propagation channel can lead to multipath diversity implementable using a Rake receiver.
4. The FCC and the DOC have allowed the use of unlicensed low power DSSS systems of code lengths greater than or equal to 10 in some frequency bands (the ISM bands).

It is the last advantage (i.e., advantage 4. above) that has given much interest recently to DSSS.

An obvious limitation of DSSS systems is the limited throughput they can offer. In any given bandwidth, B, a code of length N will reduce the effective bandwidth to B/N. To increase the overall bandwidth efficiency, system designers introduced Code Division Multiple Access (CDMA) where multiple DSSS communication links can be established simultaneously over the same frequency band provided each link uses a unique code that is noise-like. CDMA problems are:

1. The near-far problem: a transmitter "near" the receiver sending a different code than the receiver's desired code produces in the receiver a signal comparable with that of a "far" transmitter sending the desired code.
2. Synchronization of the receiver and the transmitter is complex (especially) if the receiver does not know in advance which code is being transmitted.

SUMMARY OF THE INVENTION

We have recognized that low power DSSS systems complying with the FCC and the DOC regulations for the ISM

bands would be ideal communicators provided the problems of CDMA could be resolved and the throughput could be enhanced. To enhance the throughput, we allow a single link (i.e., a single transceiver) to use more than one code at the same time. To avoid the near-far problem only one transceiver transmits at a time. In this patent, we present Multi-Code Direct Sequence Spread Spectrum (MC-DSSS) which is a modulation scheme that assigns up to N codes to an individual transceiver where N is the number of chips per DSSS code. When viewed as DSSS, MC-DSSS requires up to N correlators (or equivalently up to N Matched Filters) at the receiver with a complexity of the order of N² operations. When N is large, this complexity is prohibitive. In addition, a nonideal communication channel can cause InterCode Interference (ICI), i.e., interference between the N DSSS codes at the receiver. In this patent, we introduce new codes, which we refer to as "MC" codes. Such codes allow the information in a MC-DSSS signal to be decoded in a sequence of low complexity parallel operations while reducing the ICI. In addition to low complexity decoding and ICI reduction, our implementation of MC-DSSS using the MC codes has the following advantages:

1. It does not require the stringent synchronization DSSS requires. Conventional DSSS systems requires synchronization to within a fraction of a chip whereas MC-DSSS using the MC codes requires synchronization to within two chips.
2. It does not require the stringent carrier recovery DSSS requires. Conventional DSSS requires the carrier at the receiver to be phase locked to the received signal whereas MC-DSSS using the MC codes does not require phase locking the carriers. Commercially available crystals have sufficient stability for MC-DSSS.
3. It is spectrally efficient.

BRIEF DESCRIPTION OF THE DRAWINGS

FIG. 1 is a schematic showing for the Baseband Transmitter for the xth MC-DSSS frame: $d(k)=[d(1,x) d(2,x) \dots d(N,k)]$ where $c(i)=[c(1,i) c(2,i)]$ is the ith code and $Sym(k)=[sym(1,k) sym(N,k)]$ is the kth information-bearing vector containing N symbols.

FIG. 2 is a schematic showing a Baseband Receiver for the kth received MC-DSSS frame: $d'(k)=[d'(1,k) d'(2,k) \dots d'(N,k)]$ where $c(i)=[c(1,i) c(2,i) \dots c(N,i)]$ is the ith code, $Sym\hat{(k)}=[sym\hat{(1,k)} sym\hat{(2,k)} \dots sym\hat{(N,k)}]$ is the estimate of the Kth information-bearing vector $Sym(k)$ and

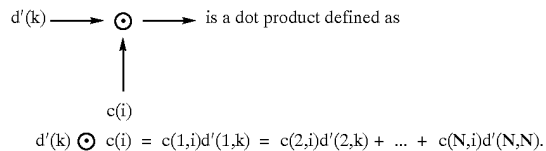

FIG. 3 is a schematic showing of the ith MC code $c(i)=[c(i,1) c(i,2) \dots c(i,NO)]$ where i can take one of the N values: 1,2, . . . N corresponding to the position of the single '1' at the input of the first N-point transform.

FIG. 4 is a schematic showing the alternate transmitter for the kth MC-DSSS frame: $d(k)=[d(1,k) d(2,k) \dots d(N,k)]$ using the MC codes generated in FIG. 3 where $Sym(k)=[Sym(1,k)Sym(2k) \dots Sym(N,k)]$ is the kth information-bearing vector contacting N symbols.

FIG. 5 is the alternate receiver for the kth received MC-DSSS frame $d'(k)=[d'(1k)d'(2,K) \dots d'(N,k)]$ using MC codes generated in FIG. 3 where $Sym\hat{(k)}=[sym\hat{(1,k)} sym\hat{(2k)} \dots sym\hat{(N,k)}]$ is the estimate of the information-bearing vector $Sym(k)$.

FIG. 6 is a schematic showing the Baseband Transmitter of the kth Data Frame $X(k)$ where $\text{Sym}(N)=[\text{sym}(1,k) \text{sym}(2,k) \dots \text{sym}(N,k)]$ is the kth information-bearing vector $d(k)=[d(1,k) d(2,k) \dots d(N,k)]$ is the kth MC-DSSS frame $v(k)=[v(1,k) v(2,k) \dots v((1+\beta)MN,k)]$, $\beta \in (0,1)$, $M=1,2,3 \dots$ and $X(k)=[x(1k) x(2,k)]$, $Z=Z=1, 2, 3, \dots$

FIG. 7 is a schematic showing the Baseband Receiver for the kth received Data Frame $X'(k)$ where $\text{Sym}(N)=[\text{sym}'(1,k) \text{sym}'(2,k) \dots \text{sym}'(N,k)]$ is the estimate of the kth information-bearing vector $d'(k)=[d'(1,k) d'(2,k) \dots d'(N,k)]$ is the kth received MC-DSSS frame $v'(k)=[v'(1,k) v'(2,k) \dots v'((1+\beta)MN,k)]$, $\beta \in (0,1)$, $M=1,2,3, \dots$ and $X'(k)=[x'(1,k) x'(2,k) \dots x'(Z,k)]$, $Z=1,2,3 \dots$

FIG. 8 is a schematic showing the Randomizer Transform (RT) where a (1) a (2) . . . a (N) are complex constants chosen randomly.

FIG. 9 is a schematic showing the Permutation Transform (PT).

FIG. 10 is a schematic showing (a) the shaping of a MC-DSSS frame and (b) the unshaping of a MC-DSSS frame where $d(k)=[d(1,k) d(2,k) \dots d(N,k)]$ is the kth MC-DSSS frame $g(k)=[g(1,k) g(2,k) \dots g(MN,k)]$, $M=1,2,3, \dots$, $v(k)=[v(1,k) v(2,k) \dots v((1+\beta)MN,k)]$, $\beta \in (0,1)$ $d'(k)=[d'(1,k) d'(2,k) \dots d'(N,k)]$ is the kth received MC-DSSS frame $g'(k)=[g'(1,k) g'(2,k) \dots g'(MN,k)]$ and $v'(k)=[v'(1,k) v'(2,k) \dots v'((1+\beta)MN,k)]$, $M=1,2,3, \dots$

FIG. 11 is a schematic showing (a) Description of the alias/window operation (b) Description of dealias/dewindow operation, where $1/T$ is the symbol rate.

FIG. 12 is a schematic showing the frame structure for data transmission from source (Node A) to destination (Node B).

FIG. 13 is a schematic showing the baseband transmitter for one request frame v where $c=[c(1) c(2) \dots c(1)]$ is the DSSS code, $v=[v(1) v(2) \dots v((1+\beta)MI)]$, $\beta \in (0,1)$, $M=1,2, \dots$ and I is the length of the DSSS code.

FIG. 14 is a schematic showing the baseband receiver for the received request frame where $c=[c(1) c(2) \dots c(1)]$ is the DSSS code for the request frame, $d'=[d'(1) d'(2) \dots d'(1)]$ is the received request frame, $v'=[v'(1) v'((1+\beta)MI)]$, $\beta \in (0,1)$, $M=1,2, \dots$ and I is the length of the DSSS code.

FIG. 15 is a schematic showing the baseband transmitter for one address frame where $c=[c(1) c(2) \dots c(1)]$ is the CDMA code for the address frame, $v=[v(1) v(2) \dots v((1+\beta)MI)]$, $\beta \in (0,1)$, $M=1,2, \dots$ and I' is the length of the CDMA code.

FIG. 16 is a schematic showing the baseband receiver the address where $c=[c(1) c(2) \dots c(I')]$ is the CDMA code for the address frame, $d'=[d'(1) d'(2) \dots d'(I)]$ is the received address frame, $v'=[v'(1) v'(2) \dots v'((1+\beta)MI')]$, $\beta \in (0,1)$, $M=1,2, \dots$ and I' is the length of the CDMA code.

FIG. 17 is a schematic showing the baseband transmitter for Ack. Frame where $c=[c(1) c(2) \dots c(I'')]$ is the DSSS code for the Ack. frame, $v=[v(1) v(2) \dots v((1+\beta)MI'')]$, $\beta \in (0,1)$, $M=1,2,3, \dots$ and I'' is the length of the DSSS code.

FIG. 18 is a schematic showing the baseband receiver for the ack. frame where $c=[c(1) c(2) \dots c(I'')]$ is the DSSS code for the Ack. frame, $d'=[d'(1) d'(2) \dots d'(I'')]$ is the received Ack. frame, $v'=[v'(1) v'(2) \dots v'((1+\beta)MI'')]$, $\beta \in (0,1)$, $M=1,2, \dots$ and I'' is the length of the DSSS code.

FIG. 19 is a schematic showing the passband transmitter for a packet where f_o is the IF frequency and f_o+f_c is the RF frequency.

FIG. 20 is a schematic showing the passband receiver for a packet where f_o is the IF frequency and f_o+f_c is the RF frequency.

DETAILED DESCRIPTION OF THE PREFERRED EMBODIMENTS OF THE INVENTION

FIG. 1 illustrates the transmitter of the MC-DSSS modulation technique generating the kth MC-DSSS frame bearing N symbols of information. The symbols can be either analog or digital.

A converter 10 converts a stream of data symbols into plural sets of N data symbols each. A computing means 12 operates on the plural sets of N data symbols to produce modulated data symbols corresponding to an invertible randomized spreading of the stream of data symbols. A combiner 14 combines the modulated data symbols for transmission. The computing means shown in FIG. 1 includes a source 16 of N direct sequence spread spectrum code symbols and a modulator 18 to modulate each ith data symbol from each set of N data symbols with the I code symbol from the N code symbol to generate N modulated data symbols, and thereby spread each I data symbol over a separate code symbol.

FIG. 2 illustrates the receiver of the MC-DSSS modulation techniques accepting the kth MC-DSSS frame and generating estimates for the corresponding N symbols of information. The dot product in FIG. 2 can be implemented as a correlator. The detector can make either hard decisions or soft decisions.

A sequence of modulated data symbols is received at 22 in which the sequence of modulated data symbols has been generated by the transmitter such as is shown in FIG. 1 or 4. A second computing means 24 operates on the sequence of modulated data symbols to produce an estimate of the second string of data symbols. The computing means 24 shown in FIG. 2 includes a correlator 26 for correlating each I modulated data symbol from the received sequence of modulated data symbols with the I code symbol from the set of N code symbols and a detector 28 for detecting an estimate of the data symbols from output of the correlator 26.

FIG. 3 illustrates the code generator of the MC codes. Any one of the P N-point transforms in FIG. 3 consists of a reversible transform to the extent of the available arithmetic precision. In other words, with finite precision arithmetic, the transforms are allowed to add a limited amount of irreversible error.

One can use the MC-DSSS transmitter in FIG. 1 and the MC-DSSS receiver in FIG. 2 together with the MC codes generated using the code generator in FIG. 3 in order to implement MC-DSSS using the MC codes.

An alternative transmitter to the one in FIG. 1 using the MC codes in FIG. 3 is shown in FIG. 4.

The alternative transmitter shown in FIG. 4 includes a transformer 20 for operating on each set of N data symbols to generate N modulated data symbols as output. A series of transforms are shown.

An alternative receiver to the one in FIG. 2 using the MC codes in FIG. 3 is shown in FIG. 5. L pilots are required in FIG. 5 for equalization.

Both transmitters in FIGS. 1 and 4 allow using shaper 30 in diversity module 32 shaping and time diversity of the MC-DSSS signal as shown in FIG. 6. We will refer to the MC-DSSS frame with shaping and time diversity as a Data frame.

Both receivers in FIGS. 2 and 5 allow diversity combining followed by the unshaping of the Data frame as shown in FIG. 7. A Synch. is required in FIG. 7 for frame synchronization.

In addition to the Data frames, we need to transmit (1) all of the L pilots used in FIG. 5 to estimate and equalize for the various types of channel distortions, (2) the Synch. signal used in FIG. 7 for frame synchronization, and (3) depending on the access technique employed, the source address, destination address and number of Data frames. We will refer to the combination of all transmitted frames as a packet.

PREFERRED EMBODIMENTS OF THE INVENTION

Examples of the N-point transforms in FIG. 3 are a Discrete Fourier Transform (DFT), a Fast Fourier Transform

5

(FFT), a Walsh Transform (WT), a Hilbert Transform (HT), a Randomizer Transform (RT) as the one illustrated in FIG. 8, a Permutator Transform (PT) as the one illustrated in FIG. 9, an Inverse DFT (IDFT), an Inverse FFT (IFFT), an Inverse WT (IWT), an Inverse HT (IHT), an Inverse RT (IRT), an Inverse PT (IPT), and any other reversible transform. When $L=2$ with the first N -point transform being a DFT and the second being a RT, we have a system identical to the patent: "Method and Apparatus for Multiple Access between Transceivers in Wireless Communications using OFDM Spread Spectrum" by M. Fattouche and H. Zaghoul, filed in the U.S. Pat Office in Mar. 31, 1992, Ser. No. 07/861,725.

Preferred shaping in FIG. 6 consists of an M th order interpolation filter followed by an alias/window operation as shown in FIG. 10a. The Alias/window operation is described in FIG. 11a where a raised-cosine pulse of rolloff β is applied. The interpolation filter in FIG. 10a can be implemented as an FIR filter or as an NM -point IDFT where the first $N(M-1)/2$ points and the last $N(M-1)/2$ points at the input of the IDFT are zero. Preferred values of M are 1,2,3 and 4.

Preferred unshaping in FIG. 7 consists of a dealias/dewindow operation followed by a decimation filter as shown in FIG. 10b. The dealias/dewindow operation is described in FIG. 11b.

Time Diversity in FIG. 6 can consist of repeating the MC-DSSS frame several times. It can also consist of repeating the frame several times then complex conjugating some of the replicas, or shifting some of the replicas in the frequency domain in a cyclic manner.

Diversity combining in FIG. 7 can consist of co-phasing, selective combining, Maximal Ratio combining or equal gain combining.

In FIG. 5, L pilots are used to equalize the effects of the channel on each information-bearing data frame. The pilot frames can consist of Data frames of known information symbols to be sent either before, during or after the data, or of a number of samples of known values inserted within two transformations in FIG. 4. A preferred embodiment of the pilots is to have the first pilot consisting of a number of frames of known information symbols. The remaining pilots can consist of a number of known information symbols between two transforms. The L estimators can consist of averaging of the pilots followed by either a parametric estimation or a nonparametric one similar to the channel estimator in the patent: "Method and Apparatus for Multiple Access between Transceivers in Wireless Communications using OFDM Spread Spectrum" by M. Fattouche and H. Zaghoul, filed in the U.S. Pat Office in Mar. 31, 1992, Ser. No. 07/861,725.

When Node A intends to transmit information to Node B, a preferred embodiment of a packet is illustrated in FIG. 12: a Request frame 40, an Address frame, an Ack. frame, a Pilot frame 36 and a number of Data frames 38. The Request frame is used (1) as a wake-up call for all the receivers in the band, (2) for frame synchronization and (3) for packet synchronization. It can consist of a DSSS signal using one PN code repeated a number of times and ending with the same PN code with a negative polarity. FIGS. 13 and 14 illustrate the transmitter and the receiver for the Request frame respectively. In FIG. 14, the dot product operation can be implemented as a correlator with either hard or soft decision (or equivalently as a filter matched to the PN code followed by a sample/hold circuit). The Request frame receiver is constantly generating a signal out of the correlator. When the signal is above a certain threshold using the level detector, (1) a wake-up call signal is conveyed to the portion of the receiver responsible for the Address frame and (2) the frames are synchronized to the wake-up call. The

6

packet is then synchronized to the negative differential correlation between the last two PN codes in the Request frame using a decoder as shown in FIG. 14.

The Address frame can consist of a CDMA signal where one out of a number of codes is used at a time. The code consists of a number of chips that indicate the destination address, the source address and/or the number of Data frames. FIGS. 15 and 16 illustrate the transmitter and the receiver for the Address frame respectively. Each receiver differentially detects the received Address frame, then correlates the outcome with its own code. If the output of the correlator is above a certain threshold, the receiver instructs its transmitter to transmit an Ack. Otherwise, the receiver returns to its initial (idle) state.

The Ack. frame is a PN code reflecting the status of the receiver, i.e. whether it is busy or idle. When it is busy, Node A aborts its transmission and retries some time later. When it is idle, Node A proceeds with transmitting the Pilot frame and the Data frames. FIGS. 17 and 18 illustrate the transmitter and the receiver for the Address frame respectively.

An extension to the MC-DSSS modulation technique consists of passband modulation where the packet is up-converted from baseband to RF in the transmitter and later down-converted from RF to baseband in the receiver. Passband modulation can be implemented using IF sampling which consists of implementing quadrature modulation/demodulation in an intermediate Frequency between baseband and RF, digitally as shown in FIGS. 19 and 20 which illustrate the transmitter and the receiver respectively. IF sampling trades complexity of the analog RF components (at either the transmitter, the receiver or both) with complexity of the digital components. Furthermore, in passband systems carrier feed-through is often a problem implying that the transmitter has to ensure a zero dc component. Such a component reduces the usable bandwidth of the channel. In IF sampling the usable band of the channel does not include dc and therefore the dc component is not a concern.

A further extension to the MC-DSSS modulation technique consists of using antenna Diversity in order to improve the Signal-to-Ratio level at the receiver. A preferred combining technique is maximal selection combining based on the level of the Request frame at the receiver.

We claim:

1. A transceiver for transmitting a first stream of data symbols, the transceiver comprising:
 - a converter for converting the first stream of data symbols into plural sets of N data symbols each;
 - first computing means for operating on the plural sets of N data symbols to produce modulated data symbols corresponding to an invertible randomized spreading of the first stream of data symbols; and
 - means to combine the modulated data symbols for transmission.
2. The transceiver of claim 1 in which the first computing means [includes] comprises:
 - a source of $[N]$ more than one and up to M direct sequence spread spectrum [code symbols] codes, where M is the number of chips per direct sequence spread spectrum code; and
 - a modulator to modulate each [ith] data symbol from each set of $[N]$ data symbols with [the ith] a code [symbol] from the $[N]$ code symbol] up to M direct sequence spread spectrum codes to generate $[N]$ modulated data symbols, and thereby spread each [ith data symbol] set of data symbols over a separate code [symbol].
3. The transceiver of claim 2 in which the [code symbols] direct sequence spread spectrum codes are generated by operation of a non-trivial $[N]$ point] transform on a sequence of input signals.

7

4. The transceiver of claim 1 in which the first computing means [includes] *comprises*:

a transformer for operating on each set of N data symbols to generate [N] modulated data symbols as output, the [N] modulated data symbols corresponding to spreading of each [ith] data symbol over a separate code [symbol] *selected from a set of more than one and up to M codes, where M is the number of chips per code; and*

means to combine the modulated data symbols for transmission.

5. The transceiver of claim 4 in which the transformer effectively applies a first transform selected from the group [comprising] *consisting of* a Fourier transform and a Walsh transform to the N data symbols.

6. The transceiver of claim 5 in which the first transform is a Fourier transform and it is followed by a randomizing transform.

7. The transceiver of claim 6 in which the first transform is a Fourier transform and it is followed by a randomizing transform and a second transform selected from the group [comprising] *consisting of* a Fourier transform and a Walsh transform.

8. The transceiver of claim 4 in which the transformer effectively applies a first inverse transform selected from the group [comprising] *consisting of* a randomizer transform, a Fourier transform and a Walsh transform to the N data symbols, followed by a first equalizer and a second inverse transform selected from the group [comprising] *consisting of* a Fourier transform and a Walsh transform.

9. The transceiver of claim 8 in which the second transform is followed by a second equalizer.

10. The transceiver of claim 1 further [including] *comprising*:

means for receiving a sequence of modulated data symbols, the modulated data symbols having been generated by invertible randomized spreading of a second stream of data symbols; *and*

second computing means for operating on the sequence of modulated data symbols to produce an estimate of the second stream of data symbols.

11. The transceiver of claim 10 further [including] *comprising* means to apply diversity to the modulated data symbols before transmission, and means to combine received diversity signals.

12. The transceiver of claim 10 in which the second computing means [includes] *comprises*:

a correlator for correlating each [ith] modulated data symbol from the received sequence of modulated data symbols with [the ith code symbol] *a code* from [the] *a set of [N code symbols] more than one and up to M codes, where M is the number of chips per code; and*

a detector for detecting an estimate of the data symbols from output of the correlator.

13. The transceiver of claim 10 in which the second computing means [includes] *comprises* an inverse transformer for regenerating an estimate of the [N] data symbols.

14. The transceiver of claim 1 further [including] *comprising* a shaper for shaping the combined modulated data symbols for transmission.

15. The transceiver of claim 1 further [including] *comprising* means to apply diversity to the combined modulated data symbols before transmission.

16. The transceiver of claim 1 in which the [N] data symbols include a pilot frame and a number of data frames, and is preceded by a request frame, wherein the request frame is used to wake up receiving transceivers, synchronize reception of the [N] data symbols and convey protocol information.

8

17. A transceiver for transmitting a first stream of data symbols and receiving a second stream of data symbols, the transceiver comprising:

a converter for converting the first stream of data symbols into plural sets of N data symbols each;

first computing means for operating on the plural sets of N data symbols to produce sets of [N] modulated data symbols corresponding to an invertible randomized spreading of each set of N data symbols over [N code symbols] *more than one and up to M direct sequence spread spectrum codes;*

means to combine the modulated data symbols for transmission;

means for receiving a sequence of modulated data symbols, the modulated data symbols having been generated by an invertible randomized spreading of a second stream of data symbols over [N code symbols] *more than one and up to M direct sequence spread spectrum codes;*

second computing means for operating on the sequence of modulated data symbols to produce an estimate of the second stream of data symbols; and

means to combine output from the second computing means.

18. The transceiver of claim 17 in which the first computing means [includes] *comprises*:

a source of [N] *the* direct sequence spread spectrum [code symbols] *codes; and*

a modulator to modulate each [ith] data symbol from each set of N data symbols with [the ith code symbol] *a code* from the [N code symbol] *up to M direct sequence spread spectrum codes* to generate [N] modulated data symbols, and thereby spread each [ith] data symbol over a separate *direct sequence spread spectrum code [symbol].*

19. The transceiver of claim 18 in which the [code symbols] *direct sequence spread spectrum codes* are generated by operation of plural non-trivial [N point] transforms on a random sequence of input signals.

20. The transceiver of claim 17 in which the first computing means [includes] *comprises*:

a transformer for operating on each set of N data symbols to generate [N] modulated data symbols as output, the [N] modulated data symbols corresponding to spreading of each [ith] data symbol over a separate code [symbol].

21. The transceiver of claim 17 in which the second computing means [includes] *comprises*:

a correlator for correlating each [ith] modulated data symbol from the received sequence of modulated data symbols with [the ith code symbol] *a code* from the [set of N code symbols] *up to M direct sequence spread spectrum codes; and*

a detector for detecting an estimate of the data symbols from the output of the correlator.

22. The transceiver of claim 17 in which the second computing means [includes] *comprises* an inverse transformer for regenerating an estimate of the N data symbols.

23. A method of exchanging data streams between a plurality of transceivers, the method comprising the steps of: converting a first stream of data symbols into plural sets of N data symbols each;

operating on the plural sets of N data symbols to produce modulated data symbols corresponding to a spreading of the first stream of data symbols over [N code symbols] *more than one and up to M direct sequence spread spectrum codes;*

9

combining the modulated data symbols for transmission;
and

transmitting the modulated data symbols from a first
transceiver at a time when no other of the plurality of
transceivers is transmitting.

24. The method of claim 23 in which the spreading is an
invertible randomized spreading and operating on the plural
sets of N data symbols [includes] *comprises* modulating
each [ith] data symbol from each set of N data symbols with
[the ith code symbol] *a code* from the [N code symbols] *up*
to M direct sequence spread spectrum codes to generate [N]
modulated data symbols, and thereby spread each [ith] data
symbol over a separate code [symbol].

25. The method of claim 23 in which the spreading is an
invertible randomized spreading and operating on the plural
sets of N data symbols [includes] *comprises*:

transforming, by application of a transform, each set of N
data symbols to generate [N] modulated data symbols
as output.

26. The method of claim 25 in which transforming each
set of N data symbols [includes] *comprises* applying to each
set of N data symbols a randomizing transform and a
transform selected from the group [comprising] *consisting of*
a Fourier transform and a Walsh transform.

27. The method of claim 25 in which transforming each
set of N data symbols [includes] *comprises* applying to each
set of N data symbols a Fourier transform, a randomizing
transform and a transform selected from the group [com-
prising] *consisting of* a Fourier transform and a Walsh
transform.

28. The method of claim 25 in which transforming each
set of N data symbols [includes] *comprises* applying to each
set of N data symbols a first transform selected from the
group [comprising] *consisting of* a Fourier transform and a
Walsh transform, a randomizing transform and a second
transform selected from the group [comprising] *consisting of*
a Fourier transform and a Walsh transform.

29. The method of claim 23 further [including] *compris-*
ing the step of:

receiving, at a transceiver distinct from the first
transceiver, the sequence of modulated data symbols;
and

operating on the sequence of modulated data symbols to
produce an estimate of the first stream of data symbols.

30. The method of claim 29 in which operating on the
sequence of modulated data symbols [includes] *comprises*
the steps of:

correlating each [ith] modulated data symbol from the
received sequence of modulated data symbols with [the
ith code symbol from the set of N code symbols] *a code*
from the up to M direct sequence spread spectrum
codes; and

detecting an estimate of the first stream of data symbols
from output of the correlator.

10

31. The method of claim 23 further [including] *compris-*
ing the step of shaping the modulated data symbols before
transmission.

32. The method of claim 23 further [including] *compris-*
ing the step of applying diversity to the modulated data
symbols before transmission.

33. A transceiver for transmitting a first stream of data
symbols, the transceiver comprising:

a converter for converting the first stream of data symbols
into plural sets of data symbols each;

first computing means for operating on the plural sets of
data symbols to produce modulated data symbols cor-
responding to an invertible randomized spreading of
the first stream of data symbols over more than one and
up to M direct sequence spread spectrum codes, where
each direct sequence spread spectrum code has M
chips; and

means to combine the modulated data symbols for trans-
mission.

34. The transceiver of claim 33 further comprising:

means for receiving a sequence of modulated data
symbols, the modulated data symbols having been
generated by invertible randomized spreading of a
second stream of data symbols; and

second computing means for operating on the sequence of
modulated data symbols to produce an estimate of the
second stream of data symbols.

35. The transceiver of claim 34 further comprising means
to apply diversity to the modulated data symbols before
transmission, and means to combine received diversity sig-
nals.

36. The transceiver of claim 34 in which the second
computing means comprises:

a correlator for correlating each modulated data symbol
from the received sequence of modulated data symbols
with a code from the set of up to M direct sequence
spread spectrum codes; and

a detector for detecting an estimate of the data symbols
from output of the correlator.

37. The transceiver of claim 34 in which the second
computing means comprises an inverse transformer for
regenerating an estimate of the data symbols.

38. The transceiver of claim 33 further comprising a
shaper for shaping the combined modulated data symbols
for transmission.

39. The transceiver of claim 33 further comprising means
to apply diversity to the combined modulated data symbols
before transmission.

40. The transceiver of claim 33 in which the data symbols
include a pilot frame and a number of data frames, and is
preceded by a request frame, wherein the request frame is
used to wake up receiving transceivers, synchronize recep-
tion of the data symbols and convey protocol information.

* * * * *

UNITED STATES PATENT AND TRADEMARK OFFICE

CERTIFICATE OF CORRECTION

PATENT NO. : RE 37,802 E
DATED : July 23, 2002
INVENTOR(S) : M.T. Fattouche et al.

Page 1 of 1

It is certified that error appears in the above-identified patent and that said Letters Patent is hereby corrected as shown below:

Title page.

Item [63], **Related U.S. Application Data**, insert in appropriate order

-- **Related U.S. Application Data**

[63] Continuation-in-part of U.S. application
No. 07/861,725, filed on Mar. 31, 1992, now Pat.
No. 5,282,222 --

Signed and Sealed this

Eleventh Day of March, 2003

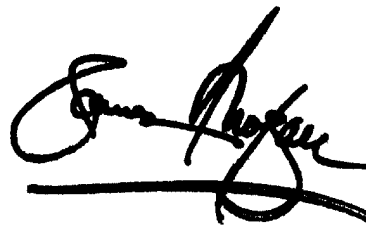
A handwritten signature in black ink, appearing to read "James E. Rogan", written over a horizontal line.

JAMES E. ROGAN
Director of the United States Patent and Trademark Office

EXHIBIT B



US006192068B1

(12) **United States Patent**
Fattouche et al.

(10) **Patent No.:** US 6,192,068 B1
 (45) **Date of Patent:** *Feb. 20, 2001

(54) **MULTICODE SPREAD SPECTRUM COMMUNICATIONS SYSTEM**

(75) Inventors: **Michel T. Fattouche; Hatim Zaghoul; Paul R. Milligan; David L. Snell**, all of Calgary (CA)

(73) Assignee: **Wi-Lan Inc.**, Alberta (CA)

(*) Notice: This patent issued on a continued prosecution application filed under 37 CFR 1.53(d), and is subject to the twenty year patent term provisions of 35 U.S.C. 154(a)(2).

Under 35 U.S.C. 154(b), the term of this patent shall be extended for 0 days.

(21) Appl. No.: **08/725,556**

(22) Filed: **Oct. 3, 1996**

(51) **Int. Cl.**⁷ **H04B 15/00**

(52) **U.S. Cl.** **375/200**

(58) **Field of Search** 375/200, 206, 375/208, 204, 219; 370/342, 468, 335

(56) **References Cited**

U.S. PATENT DOCUMENTS

3,789,149	1/1974	Clark .	
3,956,619	5/1976	Mundy et al. .	
4,164,628	8/1979	Ward et al.	375/208

(List continued on next page.)

FOREIGN PATENT DOCUMENTS

1 203 576	4/1986	(CA) .
0 562 868 A2	9/1993	(EP) .
0 567 771 A2	11/1993	(EP) .
0 605 955 A2	7/1994	(EP) .
2 146 875	4/1985	(GB) .

OTHER PUBLICATIONS

Poletti, M.A. and R.G. Vaughan, "Reduction of Multipath Fading Effects in Single Variable Modulations," *ISSPA 90 Signal Processing Theories, Implementations and Applications*, Gold Coast, Australia, pp. 672-676, Aug. 1990.

Casas, E.F. and C. Leung, "OFDM for Data Communication over Mobile Radio FM Channels; Part II: Performance Improvement," University of British Columbia, 13 pages, 1991.

Casas, E.F. and C. Leung, "OFDM for Data Communication over Mobile Radio FM Channels; Part I: Analysis and Experimental Results," *IEEE Transactions on Communications*, 39(5):783-793, May 1991.

(List continued on next page.)

Primary Examiner—Chi H. Pham

Assistant Examiner—Khai Tran

(74) *Attorney, Agent, or Firm*—Christensen O'Connor Johnson Kindness PLLC

(57) **ABSTRACT**

MultiCode Spread Spectrum (MCSS) is a modulation scheme that assigns a number N of Spread Spectrum (SS) codes to an individual user where the number of chips per SS code is M. When viewed as Direct Sequence Spread Spectrum, MCSS requires up to N correlators (or equivalently up to N Matched Filters) at the receiver with a complexity of the order of NM operations. In addition, a non ideal communication channel can cause InterCode Interference (ICI), i.e. interference between the N SS codes. In this patent, we introduce three new types of MCSS. MCSS Type I allows the information in a MCSS signal to be detected using a sequence of partial correlations with a combined complexity of the order of M operations. MCSS Type II allows the information in a MCSS signal to be detected in a sequence of low complexity parallel operations which reduce the ICI. MCSS Type III allows the information in a MCSS signal to be detected using a filter suitable for ASIC implementation or on Digital Signal Processor, which reduces the effect of multipath. In addition to low complexity detection and reduced ICI, MCSS has the added advantage that it is spectrally efficient.

11 Claims, 22 Drawing Sheets

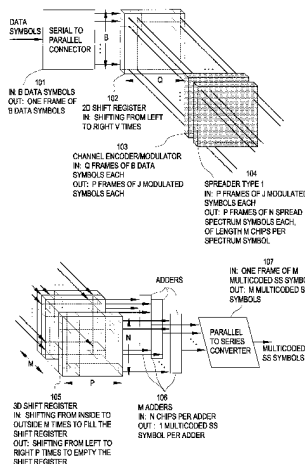

US 6,192,068 B1

Page 2

U.S. PATENT DOCUMENTS

4,601,005	7/1986	Kilvington	364/602
4,615,040	9/1986	Mojoli et al. .	
4,623,980	11/1986	Vary	364/724.1
4,641,318	2/1987	Addeo .	
4,694,466	9/1987	Kadin	375/202
4,829,540	5/1989	Waggener, Sr. et al.	375/202
4,881,241	11/1989	Pommier et al. .	
4,893,266	1/1990	Deem	364/726.03
4,901,307	2/1990	Gilhousen et al. .	
4,914,699	4/1990	Dunn et al.	380/34
4,928,310	5/1990	Goutzoulis et al.	380/46
4,933,952	6/1990	Albrieux et al.	375/200
4,944,009	7/1990	Micali et al.	380/46
4,979,183	12/1990	Cowart	375/206
5,029,180	7/1991	Cowart	375/206
5,034,911	7/1991	Rachels	364/726.01
5,063,560	11/1991	Yerbury et al.	370/335
5,063,574	11/1991	Moose .	
5,073,899	12/1991	Collier et al. .	
5,089,982	2/1992	Gran et al.	364/725.02
5,103,459	4/1992	Gilhousen et al.	370/209
5,128,964	7/1992	Mallory .	
5,134,464	7/1992	Basile et al. .	
5,151,919	9/1992	Dent	370/209
5,157,686	10/1992	Omura et al.	375/200
5,166,924	11/1992	Moose .	
5,166,951	11/1992	Schilling .	
5,193,094	3/1993	Viterbi	375/341
5,210,770	5/1993	Rice	375/200
5,235,614	8/1993	Bruckert et al.	370/209
5,268,926	12/1993	Sebilet	375/200
5,278,844	1/1994	Murphy et al.	714/778
5,282,222	1/1994	Fattouche et al.	375/200
5,285,474	2/1994	Chow et al. .	
5,291,515	3/1994	Uchida et al. .	
5,307,376	4/1994	Castelain et al. .	
5,309,474	5/1994	Gilhousen et al.	370/209
5,357,541	10/1994	Cowart	375/206
5,373,502	12/1994	Turban .	
5,375,140	12/1994	Bustamente et al. .	
5,414,734	5/1995	Marchetto et al. .	
5,416,797	5/1995	Gilhousen et al.	370/209
5,442,625	8/1995	Gitlin et al.	370/342
5,467,367 *	11/1995	Izumi et al.	375/206
5,469,469	11/1995	Haines	375/201
5,479,447	12/1995	Chow et al. .	
5,487,069	1/1996	O'Sullivan et al. .	
5,555,268	9/1996	Fattouche et al.	375/206
5,596,601	1/1997	Bar-David .	
5,615,209 *	3/1997	Bottomley et al.	370/342
5,623,511	4/1997	Bar-David et al. .	
5,715,236	2/1998	Gilhousen et al. .	
5,761,429 *	6/1998	Thompson	395/200.54
5,960,032	9/1999	Lataief et al. .	

OTHER PUBLICATIONS

Hoehner, P., J. Hagenauer, E. Offer, Ch. Rapp, H. Schulze, "Performance of an RCPC-Coded OFDM-based Digital Audio Broadcasting (DAB) System," *Globecom '91*, CH2980-1/91/0000-0040, pp. 0040-0046, 1991.

Kalet, I., "The Multitone Channel," *IEEE Transactions on Communications*, 37(2):119-124, Feb. 1989.

Zervos, N.A. and I. Kalat, "Optimized Decision Feedback Equalization versus Optimized Orthogonal Frequency Division Multiplexing for High-Speed Data Transmission Over the Local Cable Network," *IEEE*, CH2655-9/89/0000-1980, pp. 1080-1085, 1989.

Hirosaki, B., S. Hasegawa, and A. Sabato, "Advanced Groupband Data Modem Using Orthogonally Multiplexed QAM Technique," *IEEE Transactions on Communications*, vol. Com-34, No. 6, pp. 587-592, Jun. 1986.

Hirosaki, B., A. Yoshida, O. Tanaka, S. Hasegawa, K. Inoue, and K. Watanabe, "A 19.2 Kpbs Voiceband Data Modem Based on Orthogonally Multiplexed QAM Techniques," *IEEE*, CH2175-8/85/0000-0661, pp. 661-665, 1985.

Cimini, L.J. Jr., "Analysis and Simulation of a Digital Mobile Channel Using Orthogonal Frequency Division Multiplexing," *IEEE Transactions on Communications*, vol. Com-33, No. 7, pp. 665-675, Jul. 1985.

Hirosaki, B., "An Orthogonally Multiplexed QAM System Using the Discrete Fourier Transform," *IEEE Transactions on Communications*, vol. Com-294, No. 7, pp. 982-989, Jul. 1981.

Hirosaki, B., "Analysis of Automatic Equalizers for Orthogonally Multiplexed QAM Systems," *IEEE Transactions on Communications*, vol. Com-28, No. 1, pp. 73-83, Jan. 1980.

Maruta, R. and A. Tomozawa, "An Improved Method for Digital SSB-FDM Modulation and Demodulation," *IEEE Transactions on Communications*, vol. Com-26, No. 5, pp. 720-725, May 1978.

Weinstein, S.B., and P.M. Ebert, "Data Transmission by Frequency-Division Multiplexing Using the Discrete Fourier Transform," *IEEE Transactions on Communication Technology*, vol. Com-19, No. 5, pp. 628-634, Oct. 1971.

Saltzberg, B.R., "Performance of an Efficient Parallel Data Transmission System," *IEEE Transactions on Communication Technology*, vol. Com-15, No. 6, pp. 805-811, Dec. 1967.

Chang, R.W. and R.A. Gibby, "A Theoretical Study of Performance of an Orthogonal Multiplexing Data Transmission Scheme," *IEEE Transactions on Communication Technology*, vol. Com-16, No. 4, pp. 529-540, Aug. 1968.

Chang, R.W., "Synthesis of Band-Limited Orthogonal Signals for Multichannel Data Transmission," *The Bell System Technical Journal*, pp. 1775-1796, Dec. 1966.

Gledhill, J.J., et al., "The Transmission of Digital Television In The UHF Band Using Orthogonal Frequency Division Multiplexing," pp. 175-180.

Duch, Krzysztof M., "Baseband Signal Processing," *Network Magazine*, pp. 39-43.

Ananasso, Fulvio, et al., "Clock Synchronous Multicarrier Demodulator For Multi-Frequency TDMA Communication Satellites," pp. 1059-1063.

Saito, Masafumi, et al., "A Digital Modulation Method For Terrestrial Digital TV Broadcasting Using Trellis Coded OEDM And Its Performance," pp. 1694-1698.

Alard, M., et al., "A New System Of Sound Broadcasting To Mobile Receivers," pp. 416-420.

Chow, Jacky S., et al., "A Discrete Multitone Transceiver System For HDSL Applications," pp. 895-908.

Chow, Peter S., et al., "Performance Evaluation of a Multichannel Transceiver System for ADSL and VHDSL Services," pp. 909-919.

Pupolin, Silvao, et al., "Performance Analysis Of Digital Radio Links With Nonlinear Transmit Amplifier And Data Predistorter With Memory," pp. 9.6.1-9.6.5.

Bingham, J.A.C., "Multicarrier Modulation for Data Transmission: An Idea Whose Time Has Come", *IEEE Communications Magazine*, pp. 5-14, May 1990.

Spracklen, C.T. and C. Smythe, "The Application of Code Division Multiplexing Techniques to Local Area Networks," pp. 767-770, May 1987.

* cited by examiner

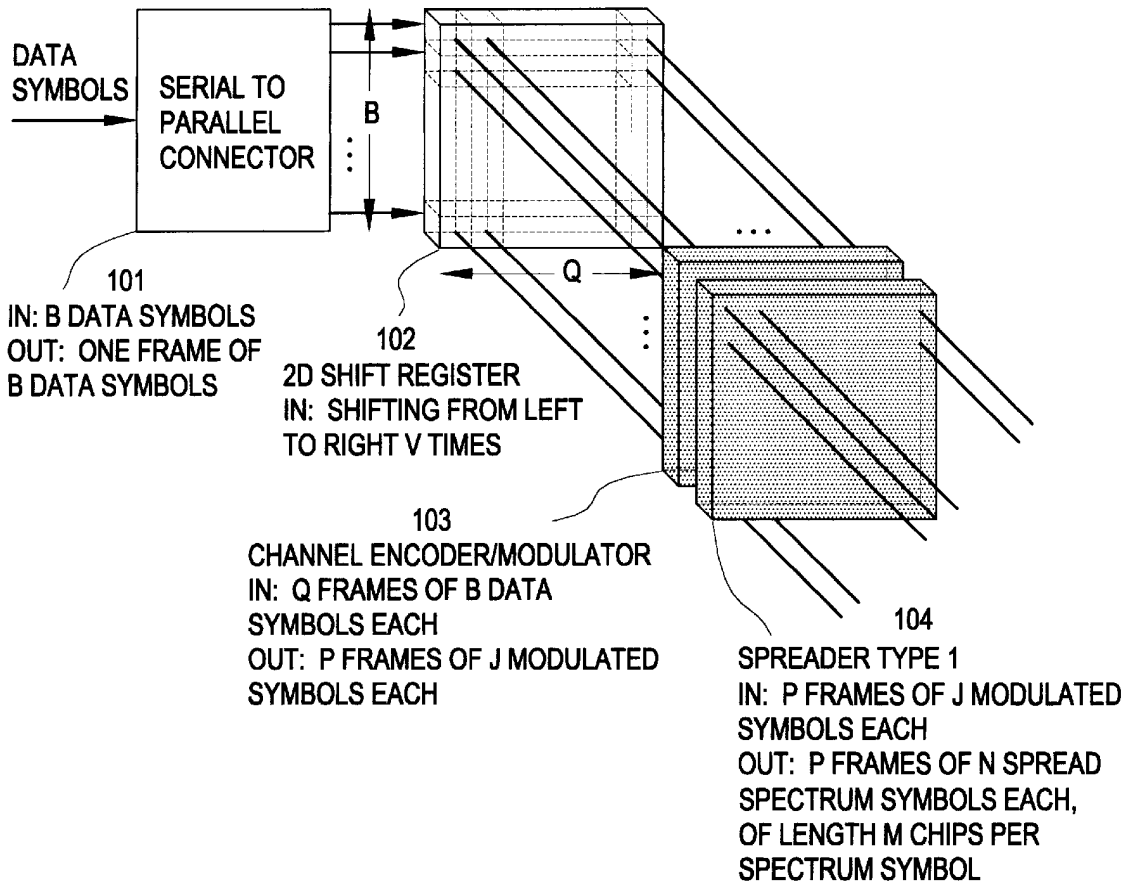
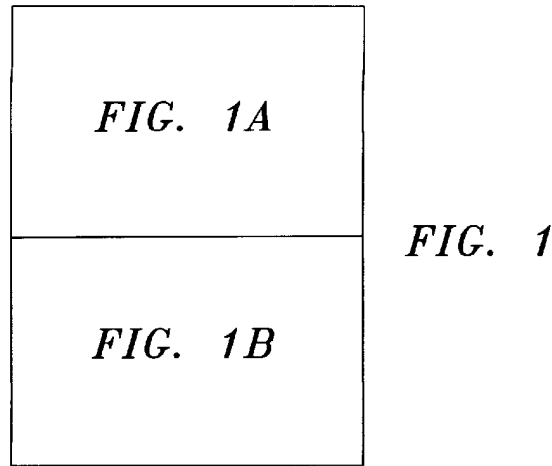
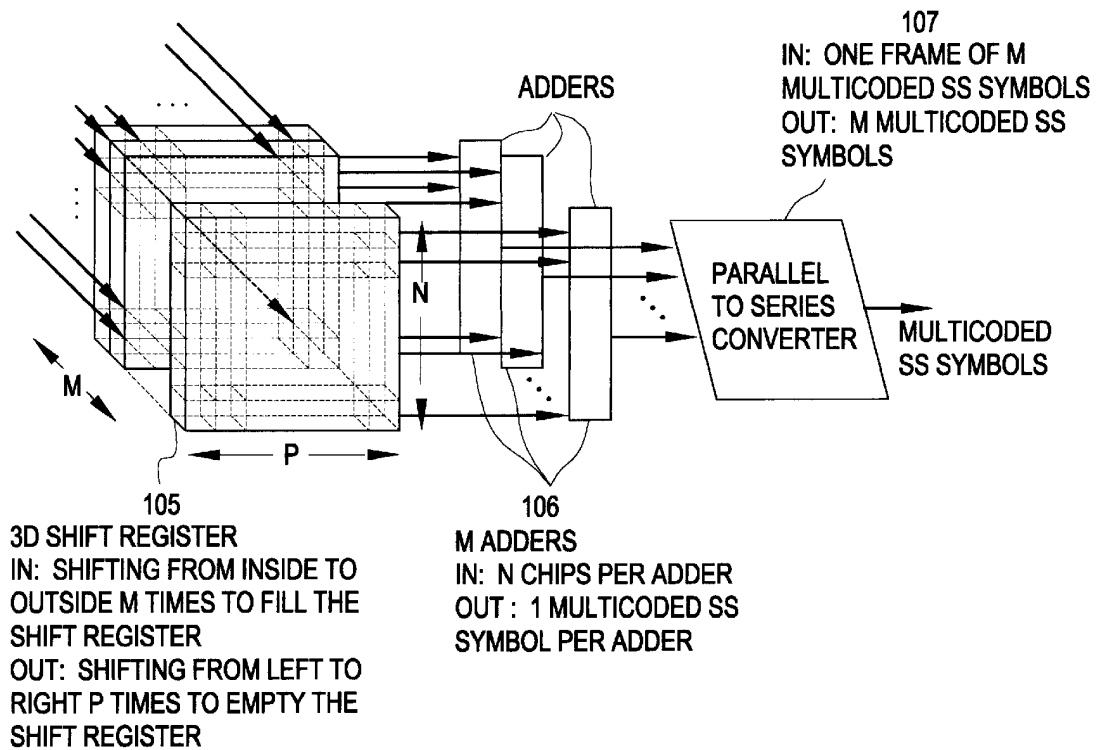

FIG. 1A

FIG. 1B



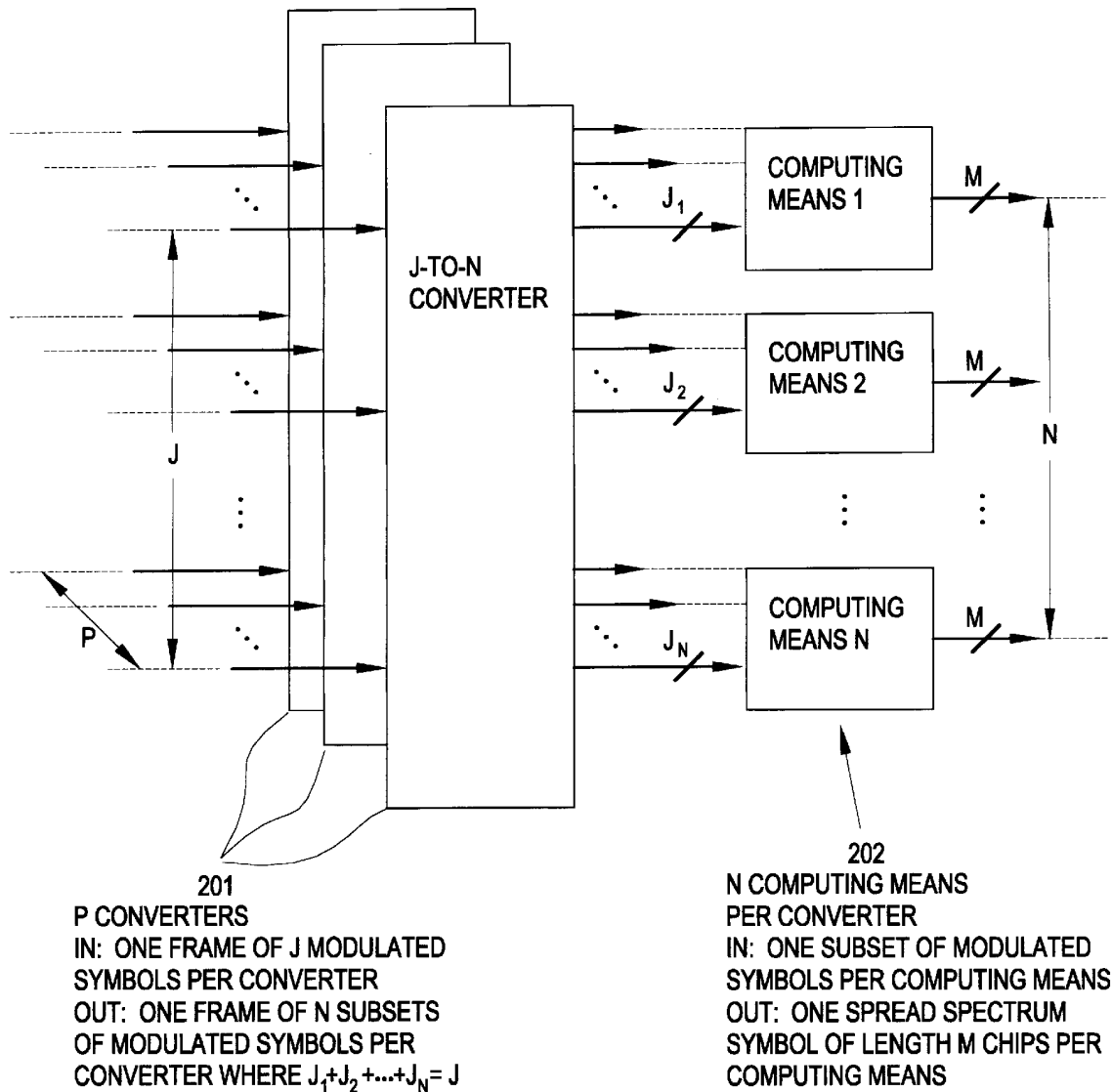
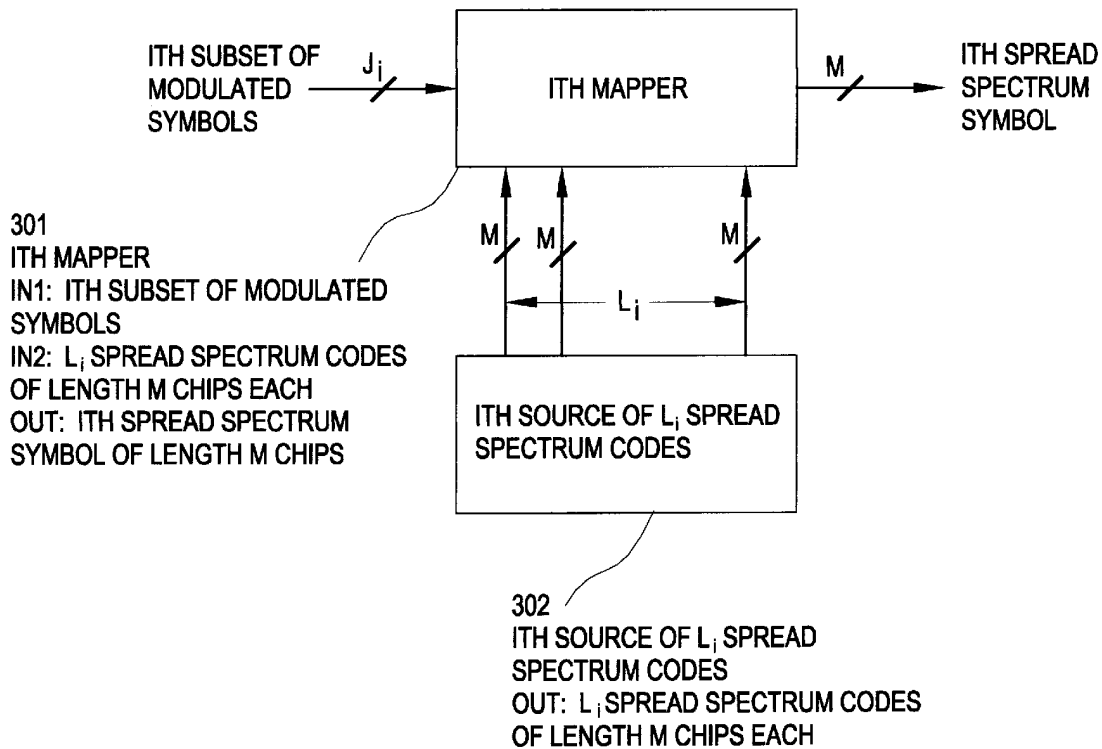

FIG. 2

FIG. 3



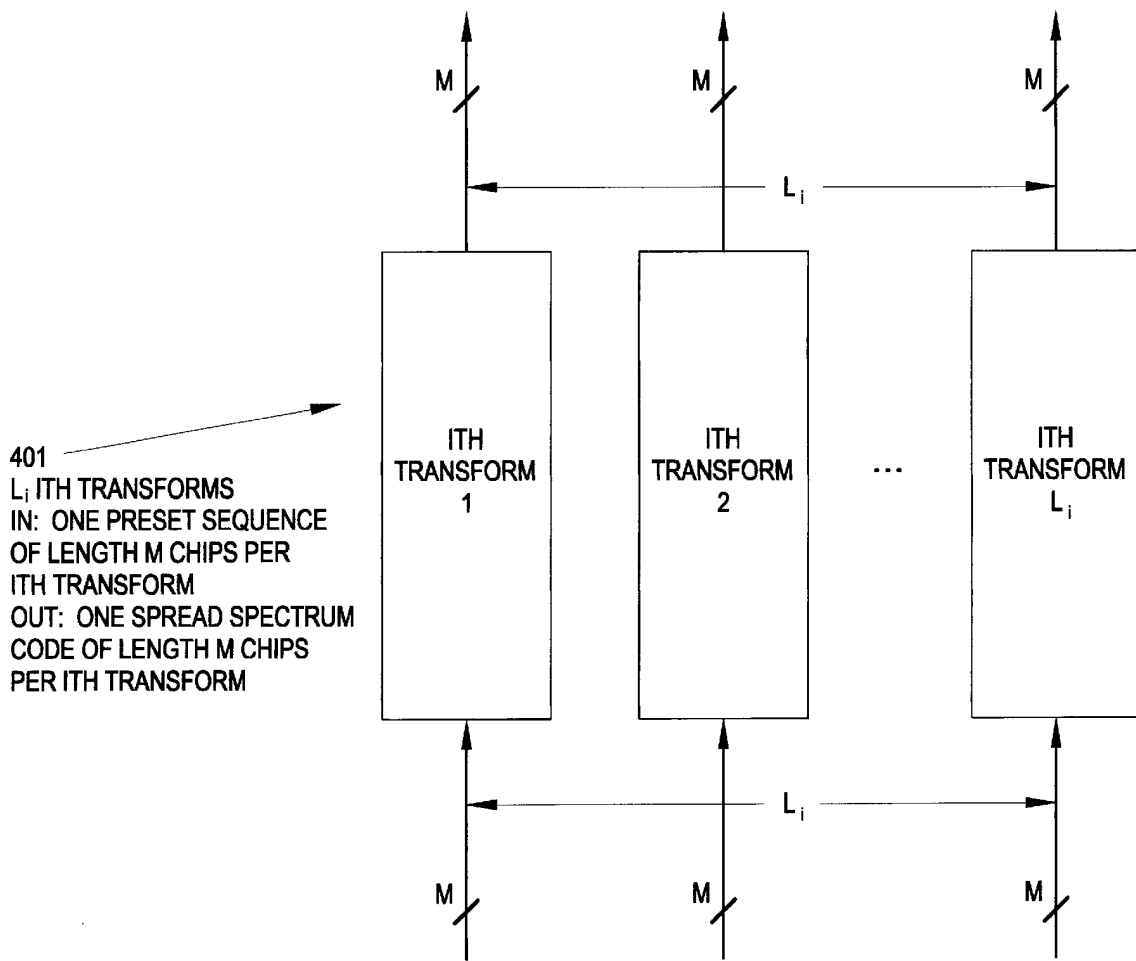
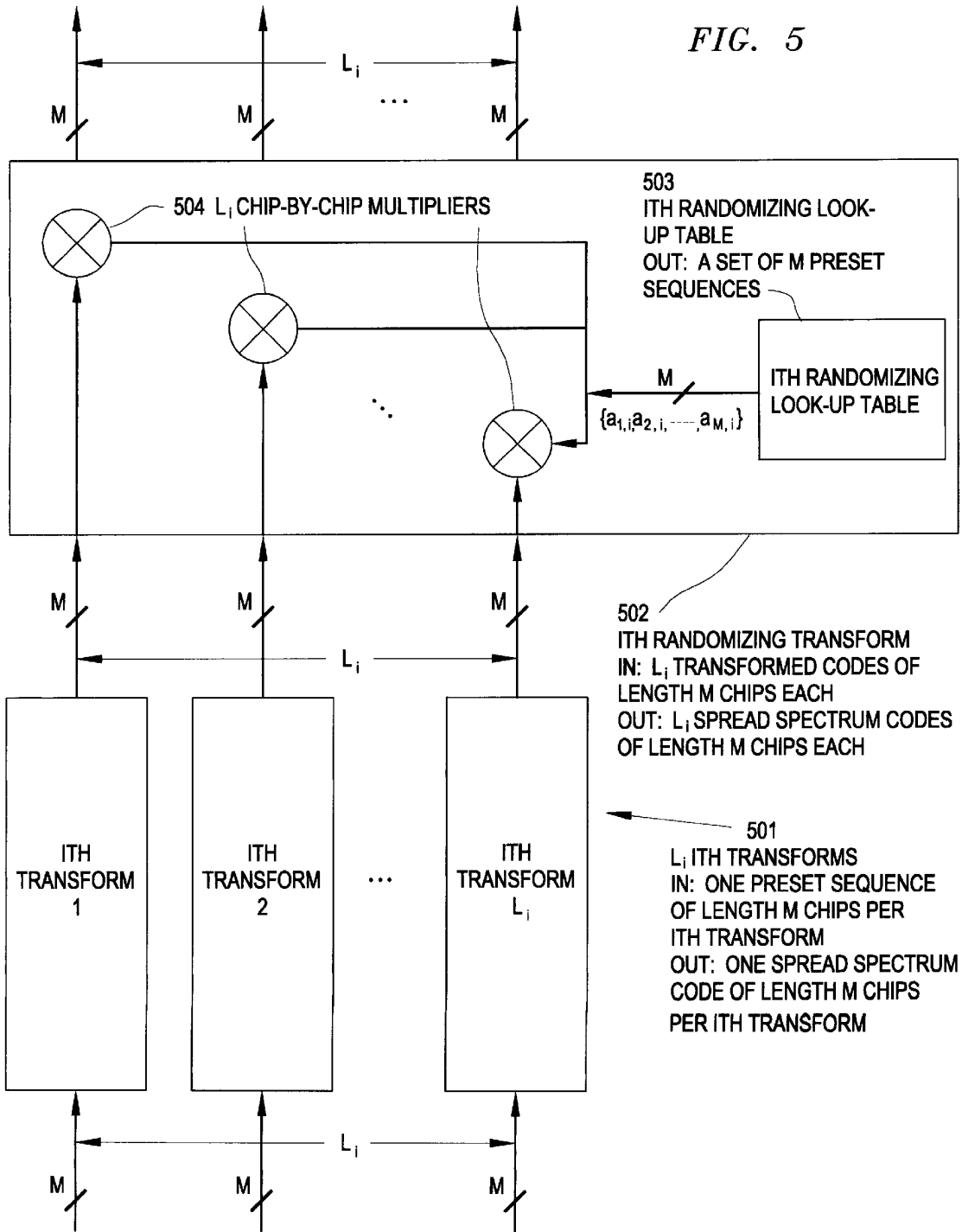

FIG. 4

FIG. 5



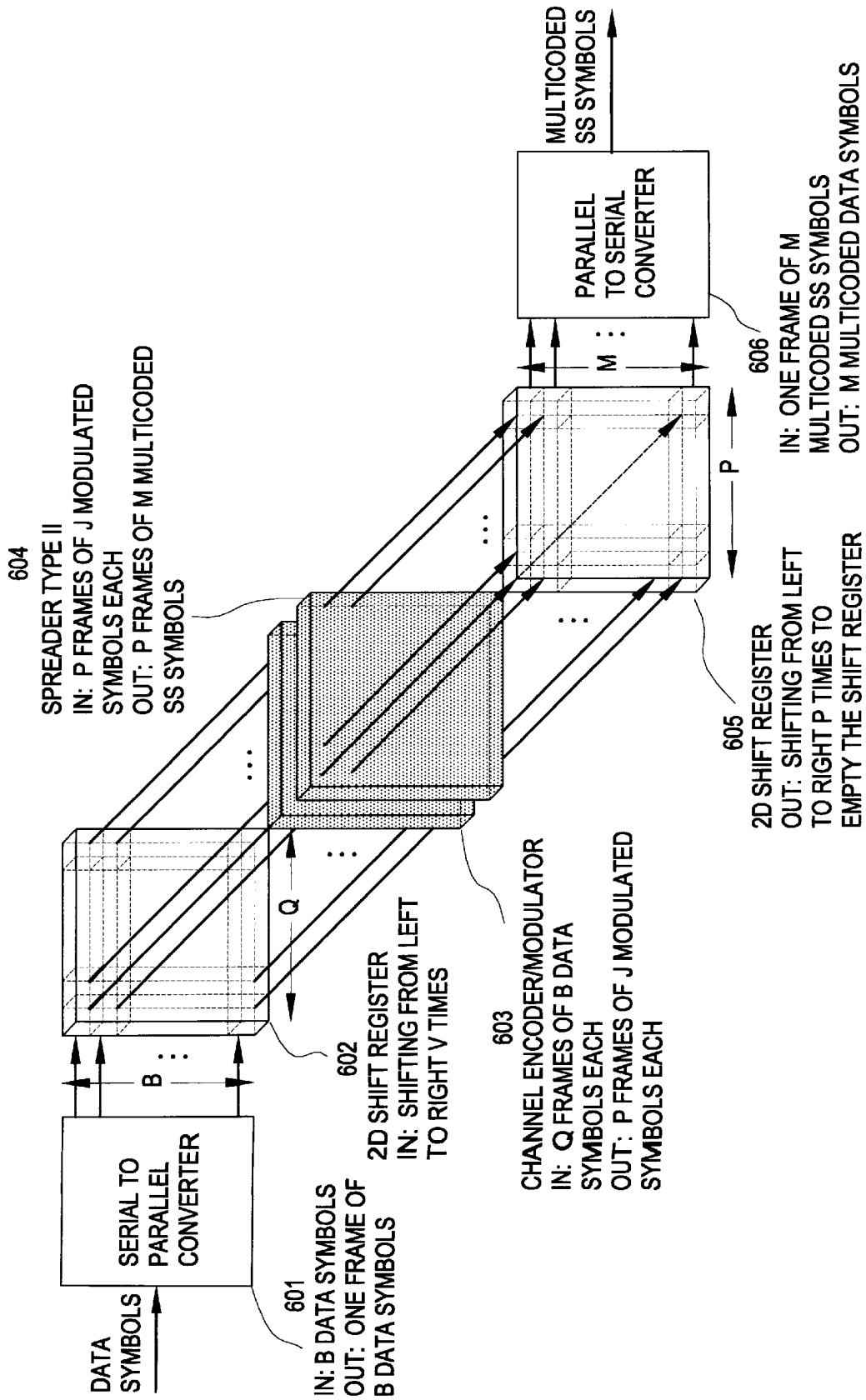

FIG. 6

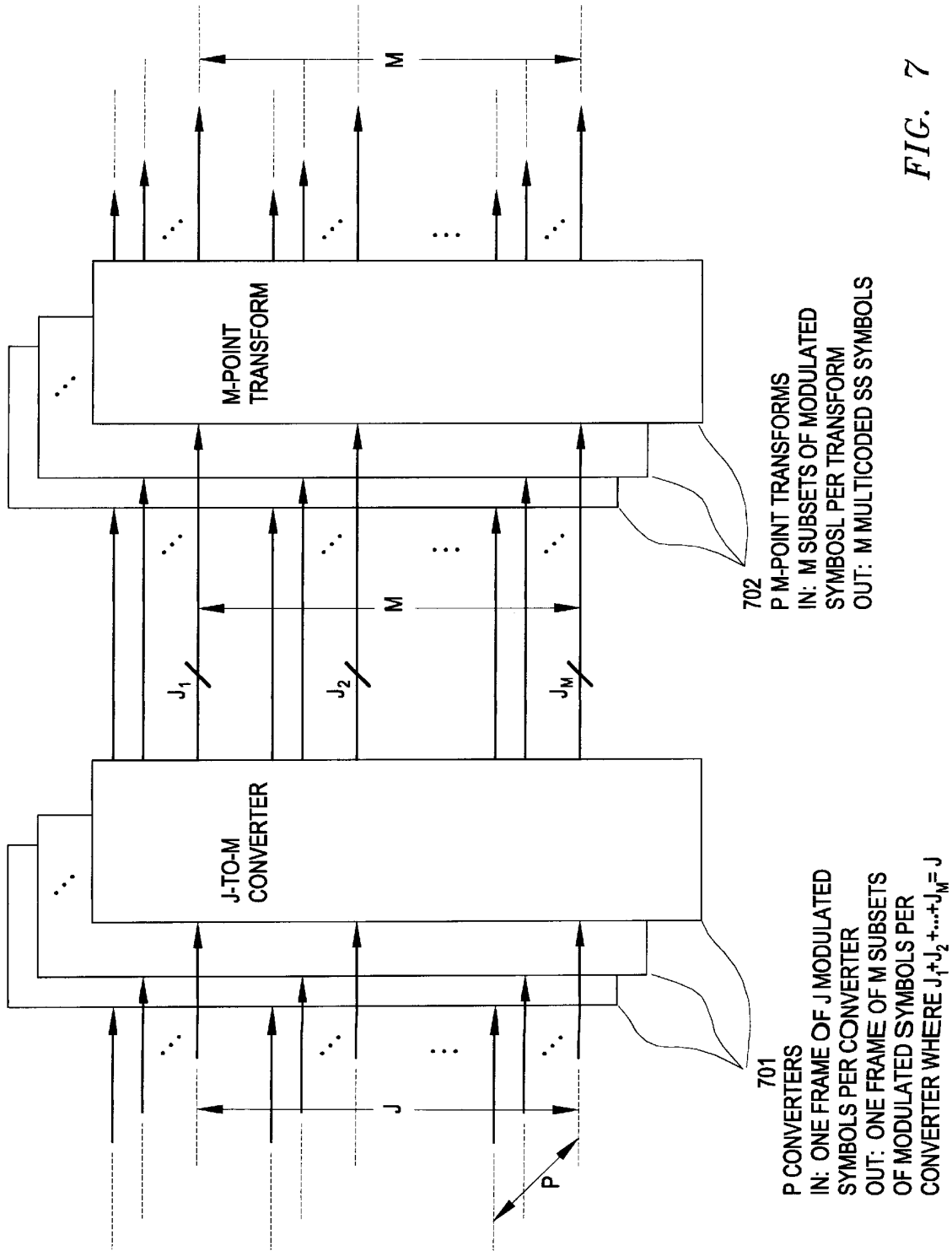
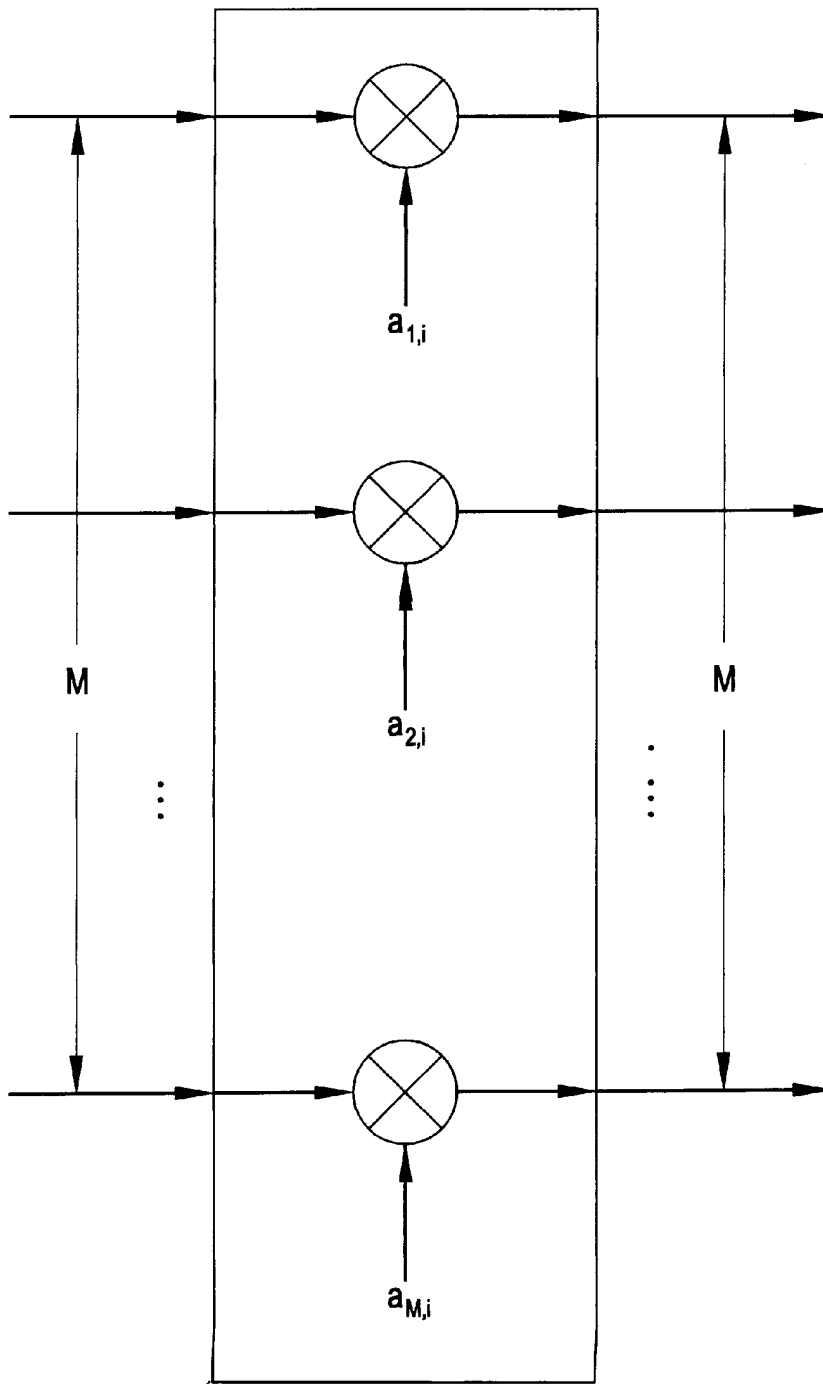

FIG. 8



801

ITH M-POINT RANDOMIZING TRANSFORM
IN: M SUBSETS OF MODULATED SYMBOLS
OUT: M MULTICODED SS SYMBOLS

FIG. 9

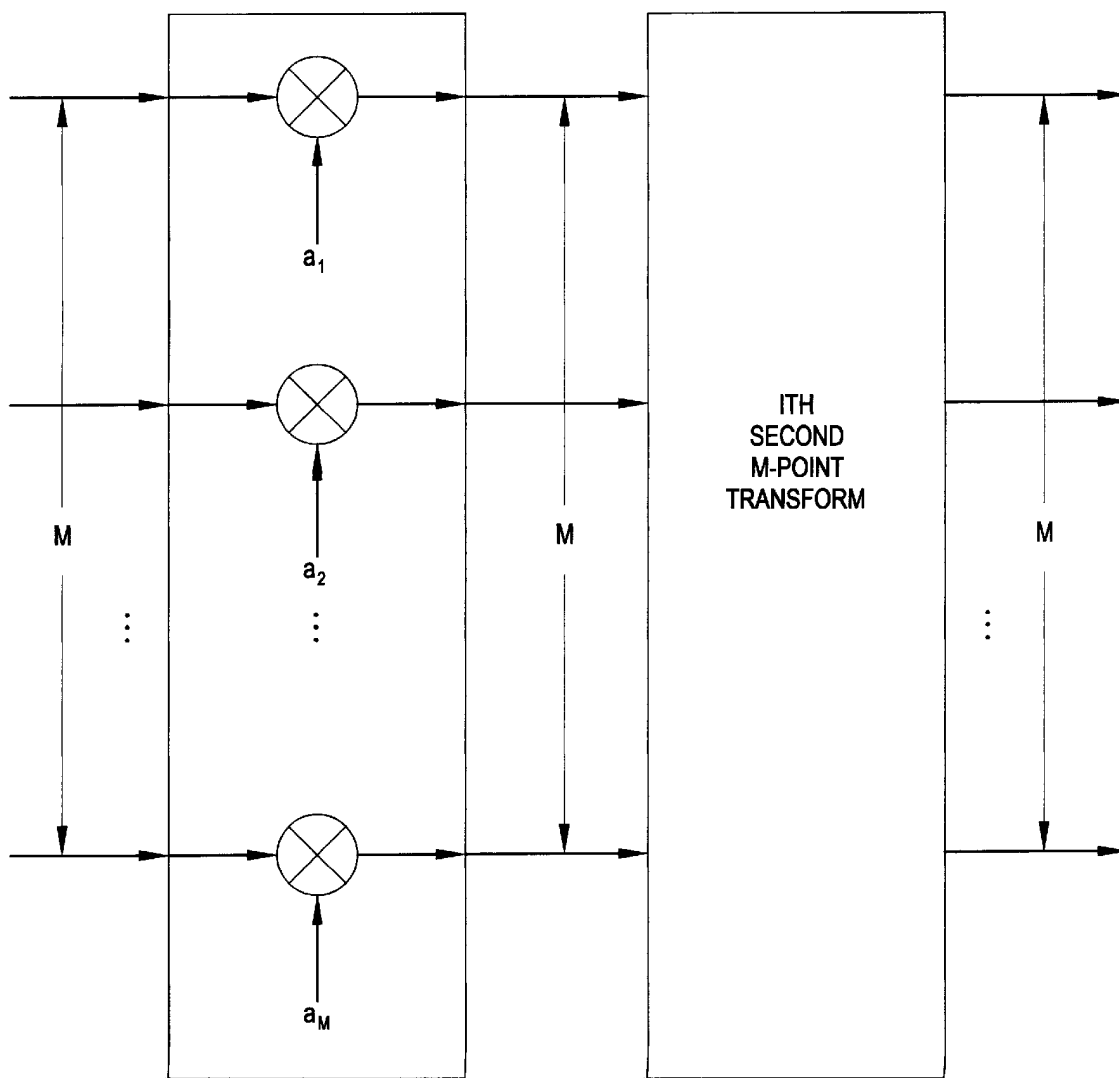

901
 ITH M-POINT RANDOMIZING TRANSFORM
 IN: M SUBSETS OF MODULATED SYMBOLS
 OUT: M TRANSFORMED SYMBOLS

902
 ITH SECOND M-POINT TRANSFORM
 IN: M TRANSFORMED SYMBOLS
 OUT: M MULTICODED SS SYMBOLS

FIG. 10

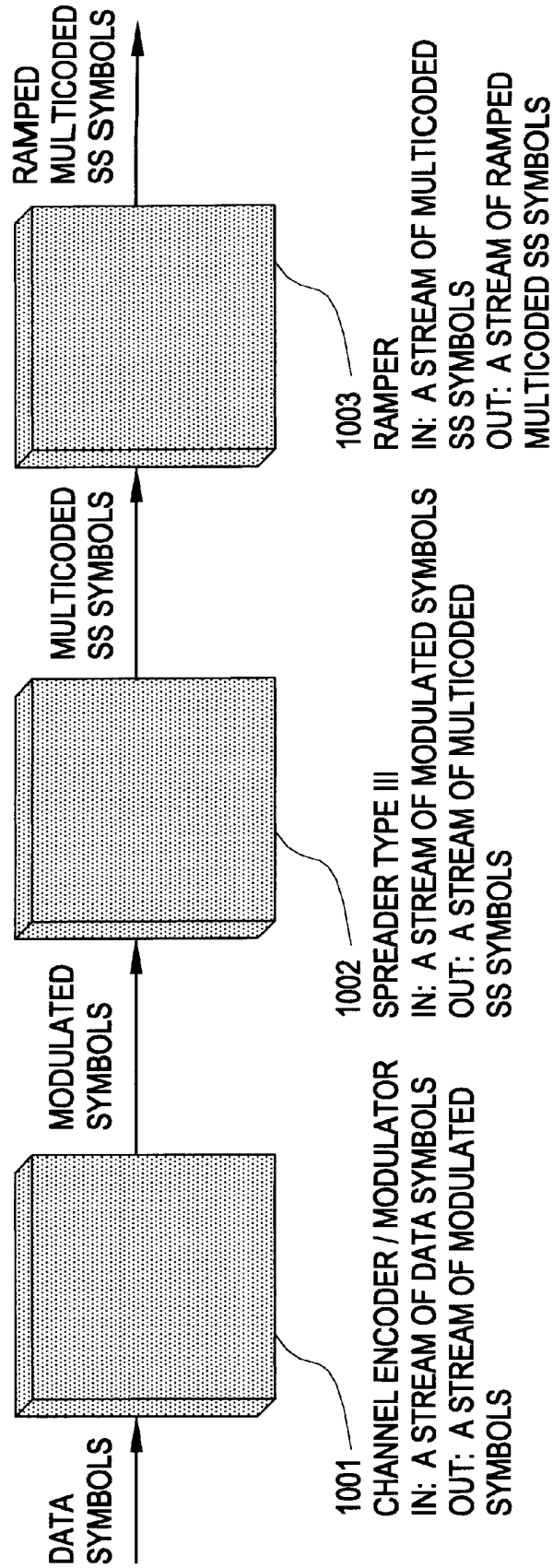

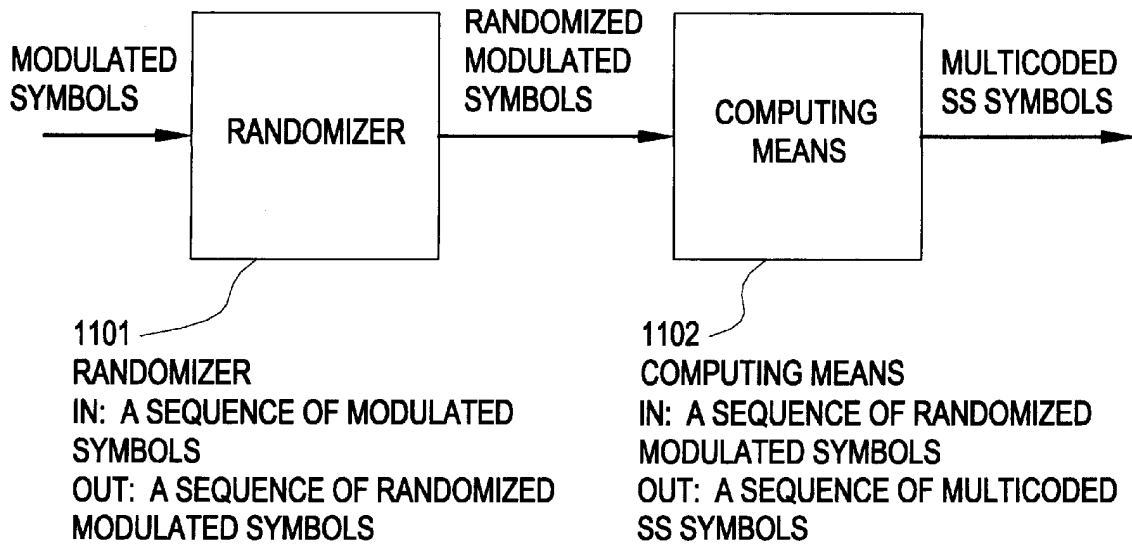

FIG. 11

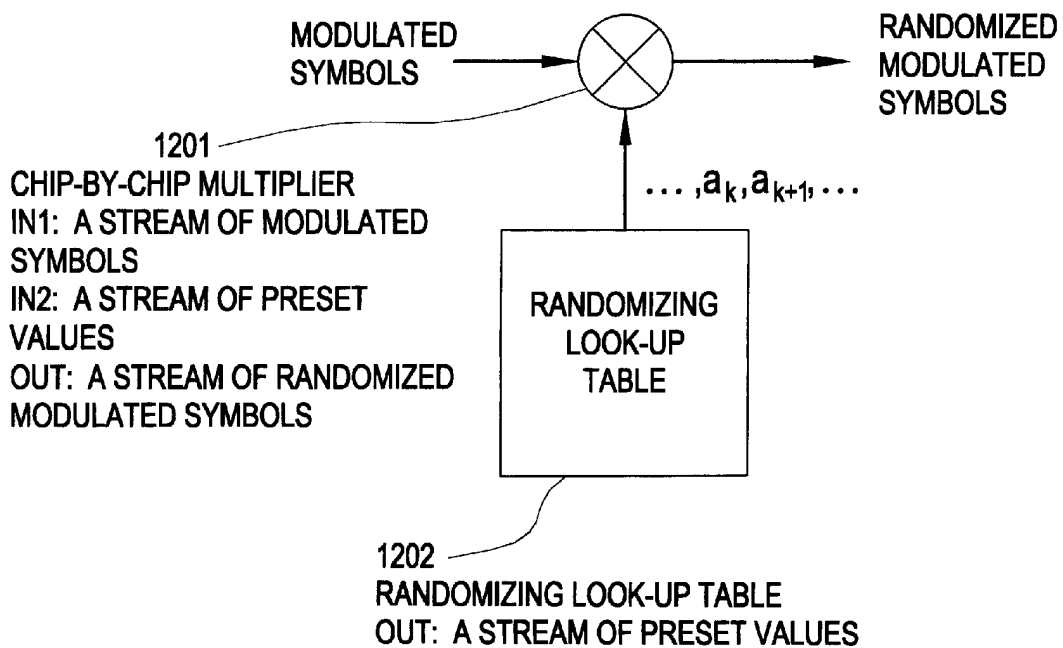

FIG. 12

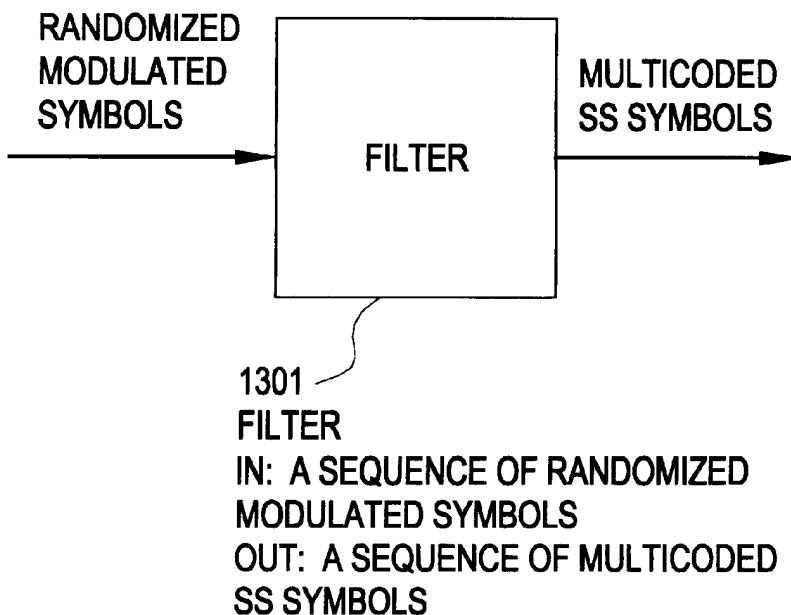

FIG. 13

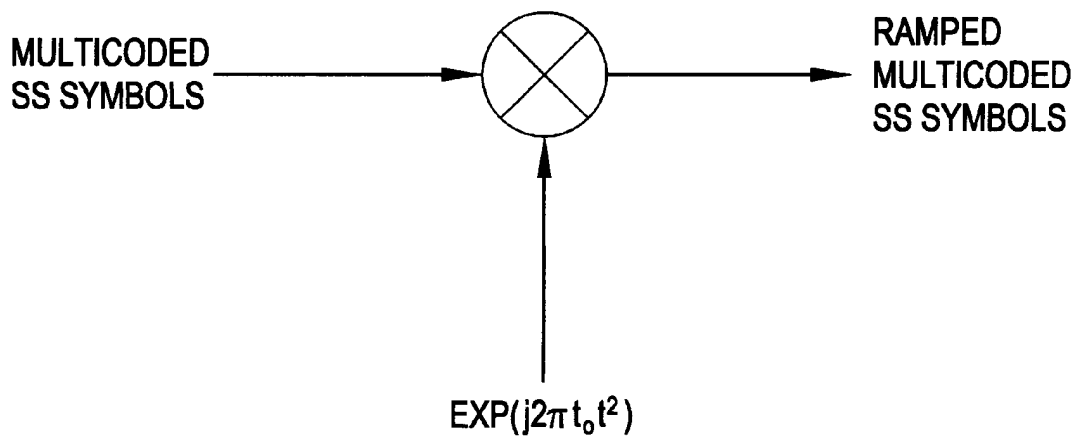

FIG. 14

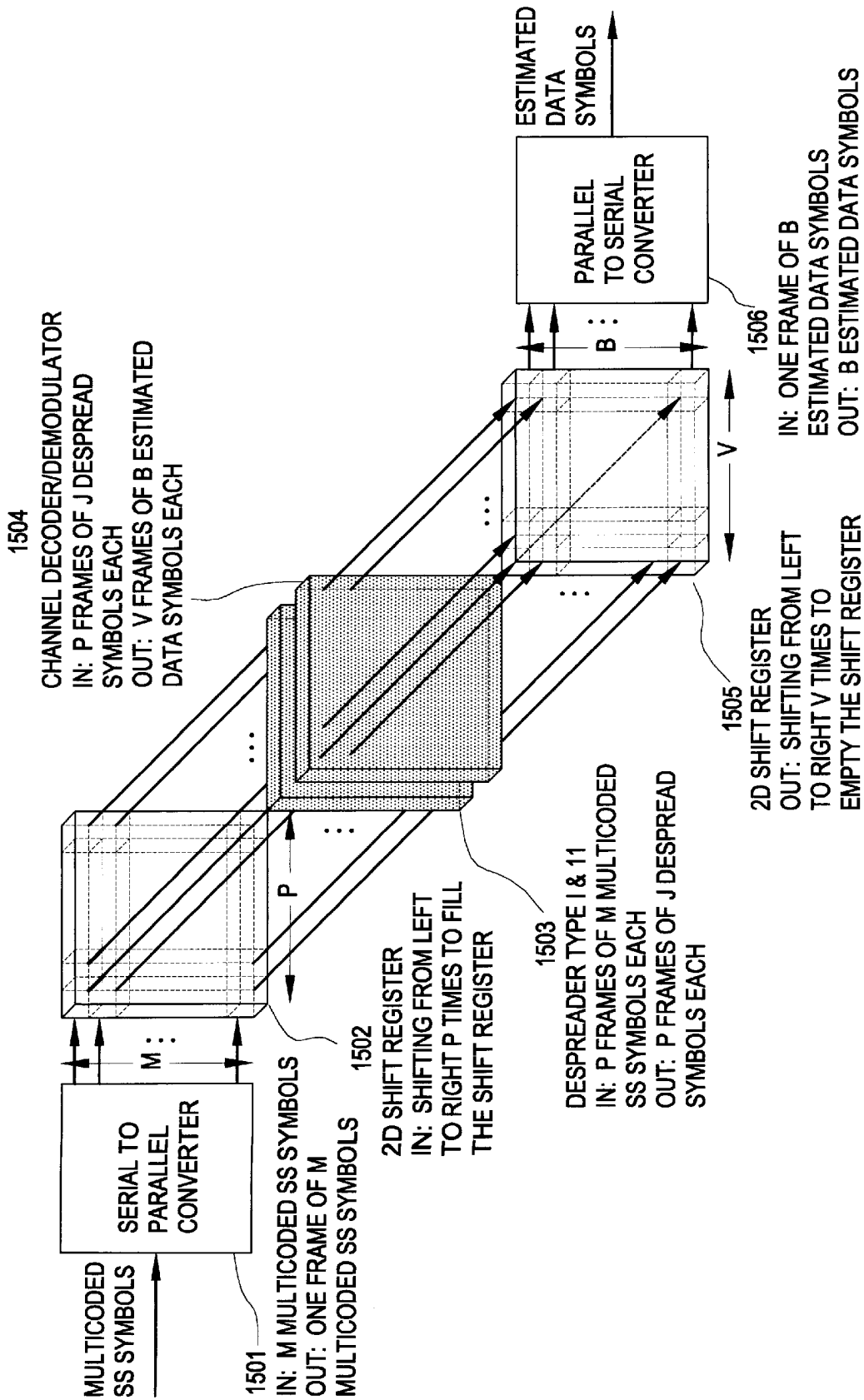

FIG. 15