

# ORIGINAL

**IN THE UNITED STATES DISTRICT COURT  
FOR THE NORTHERN DISTRICT OF GEORGIA**

FILED IN CLERK'S OFFICE  
Atlanta  
APR 29 2005  
By [Signature] U.S. Clerk  
Deputy Clerk

**Elster Electricity LLC,**

**Plaintiff,**

**v.**

**IPCO, LLC,**

**Defendant.**

)  
)  
)  
)  
)  
)  
)  
)  
)  
)  
)  
)

Civil Action No.: **1 05 - CV 1138**

**JURY TRIAL DEMANDED**

**CC**

### **COMPLAINT**

Plaintiff Elster Electricity LLC hereby complains and alleges against Defendant IPCO, LLC as follows

#### **PARTIES**

1 Elster Electricity LLC ("Elster") is Delaware corporation having its principal place of business at 208 South Rogers Lane, Raleigh, NC 27610 Elster is in the business of developing, manufacturing and selling electricity metering products and metering automation systems

2 On information and belief, IPCO, LLC ("IPCO") has its principal place of business at 200 Galleria Parkway, Suite 1820, Atlanta, GA 30339 On information and belief, IPCO has no business other than licensing and enforcing patents

3  
2  
1  
TS

**JURISDICTION**

3 This is a civil action for patent infringement arising under the patent laws of the  
United States. Title 35 of the United States Code The Court has jurisdiction over the subject  
matter of this action under 28 U S C §§ 1331, 1338(a), 2201 and 2202

4 Venue is proper in this District under 28 U S C §§ 1391(b) & (c) and 1400(b)

**FACTUAL BACKGROUND**

**U.S. Patent No. 6,249,516**

5 On June 19, 2001, the United States Patent and Trademark Office issued U S  
Patent No 6,249,516 (“the 516 patent”). entitled “Wireless Network Gateway and Method for  
Providing Same” (attached hereto as Exhibit 1) The 516 patent purports to be directed to a  
server having a digital controller, a network interface, and a radio modem that provides a  
gateway between two networks. one of which is a wireless network

6 On information and belief, the 516 patent was assigned from CommUnique, LLC  
to defendant IPCO on December 11, 2004

**Facts Relating to Declaratory Judgment Jurisdiction**

7 There is an actual controversy between the parties, namely a disputed claim of  
patent infringement, and a direct threat of litigation by IPCO, for patent infringement against  
Elster

8 Outside counsel for IPCO initiated contact with Elster by letter of April 7, 2005  
(attached hereto as Exhibit 2) In the letter, counsel for IPCO alleged that “Elster’s EnergyAxis  
System infringes one or more claims of U S Patent No 6,249,516 ” Counsel further stated that  
“[g]iven the extent of Elster’s manufacturing, our client is quite concerned about the  
infringement of its intellectual property rights ” Counsel also threatened Elster with litigation.

stating that “[i]f we do not hear from you by the close of business on Monday, April 18, 2005, we will initiate litigation against Elster for infringement of the ‘516 patent ”

9 Elster responded in a letter dated April 15, 2005 (attached hereto as Exhibit 3) In the letter, Elster informed IPCO that it was currently studying the 516 patent and requested that IPCO give Elster until June of 2005 to complete the study to assess the 516 patent and IPCO’s charge of patent infringement

10 By letter of April 18, 2005 (attached hereto as Exhibit 4), outside counsel for IPCO responded that it was “unwilling to wait until June to address this matter,” but agreed to “forego filing litigation for an additional week, until April 28, 2005 ”

11 Elster met with representatives of IPCO in Raleigh, North Carolina on April 28, 2005 During the meeting, IPCO again contended that Elster’s EnergyAxis System infringed its 516 patent and offered Elster a license to the patent The terms of the license offered by IPCO were unacceptable to Elster The meeting concluded without any resolution of the dispute nor any indication from IPCO that it would further postpone the litigation that it has threatened

12 Based on IPCO’s statements that Elster’s EnergyAxis System infringes the 516 patent and IPCO’s stated intention to file a lawsuit against Elster, Elster has a reasonable apprehension that it will be sued by IPCO for patent infringement related to its EnergyAxis System

13 The threat of suit by IPCO is imminent because the parties have terminated licensing negotiations and IPCO has provided no indication that it is willing to further postpone filing suit

**REQUESTED RELIEF**

**Claim I – Declaratory Judgment of Noninfringement**

14 Elster hereby incorporates the allegations contained in paragraphs 1-13 of this  
Complaint and further allege as follows

15 An actual, live and justiciable controversy exists between Elster and IPCO as to  
the infringement of the 516 patent

16 Elster's EnergyAxis System does not literally infringe any claim of the 516  
patent

17 Elster's EnergyAxis System does not infringe any claim of the 516 patent under  
the doctrine of equivalents

18 Elster is entitled to a judgment declaring that the EnergyAxis System does not  
infringe, literally or under the doctrine of equivalents, any claim of the 516 patent

**Claim II – Declaratory Judgment of Invalidity**

19 Elster hereby incorporates the allegations contained in paragraphs 1-18 of this  
Complaint and further alleges as follows

20 An actual controversy exists as to whether the claims of the 516 patent are invalid  
under 35 U S C §§ 102, 103 and 112

21 The 516 patent is invalid under one or more of 35 U S C §§ 102, 103 and 112

22 Elster is entitled to a judgment declaring that each claim of the 516 patent is  
invalid

**PRAYER FOR RELIEF**

WHEREFORE, Elster prays that this Court enter judgment as follows

a Declaring that Elster's EnergyAxis System does not infringe, literally or under the  
doctrine of equivalents, any claim of the 516 patent,

b Declaring that each of the claims of the 516 patent is invalid and that IPCO is without any right or authority to enforce or threaten to enforce any claim of the 516 patent against Elster or any other party.

c Granting Elster all monetary relief appropriate, including Elster's reasonable attorneys' fees and costs incurred in this action, and

d Granting Elster such other and further relief, either in equity or law, as the Court deems appropriate under the circumstances of this case

Elster respectfully demands a trial by jury on all issues so triable

Dated this 29<sup>th</sup> day of April 2005

Respectfully submitted,

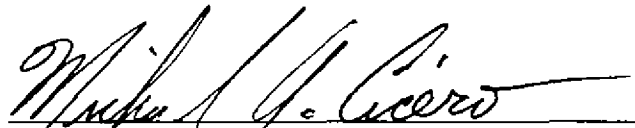
  
Michael A. Cicero (GA Bar No. 125688)  
WOMBLE CARLYLE SANDRIDGE & RICE, PLLC  
1201 W Peachtree Street  
Suite 3500  
Atlanta, Georgia 30309  
Phone (404) 872-700  
Facsimile (404) 870-8170  
E-mail mcicero@wcsr.com

ATTORNEYS FOR PLAINTIFF

Of Counsel  
Steven J. Rocci  
Steven B. Samuels  
WOODCOCK WASHBURN LLP  
One Liberty Place – 46<sup>th</sup> Floor  
Philadelphia PA. 19103  
(215) 568-3100 (phone)  
(215) 568-3439 (fax)

# **EXHIBIT 1**



US006249516B1

(12) **United States Patent**  
**Brownrigg et al.**

(10) **Patent No.:** **US 6,249,516 B1**  
 (45) **Date of Patent:** **Jun. 19, 2001**

(54) **WIRELESS NETWORK GATEWAY AND METHOD FOR PROVIDING SAME**

(76) **Inventors** **Edwin B. Brownrigg**, 328 King Rd., Roseville, CA (US) 95678, **Thomas W. Wilson**, 139 Avington Rd., Alameda, CA (US) 94502

(\*) **Notice** Subject to any disclaimer, the term of this patent is extended or adjusted under 35 U.S.C. 154(b) by 0 days

(21) **Appl No** **09/492,930**

(22) **Filed** **Jan 27, 2000**

**Related U.S. Application Data**

(62) Division of application No. 08/760,895 filed on Dec 6 1995, now Pat. No. 6,044,062

(51) **Int. Cl.** **H04L 12/66**

(52) **U.S. Cl.** **370/338; 370/401**

(58) **Field of Search** **370/338; 349, 370/352, 353, 354, 355, 356, 400, 401, 466, 467, 328, 351, 241, 455:11**

(56) **References Cited**

**U.S. PATENT DOCUMENTS**

5,282,204	*	1-1994	Shpancer et al	
5,592,491	*	1-1997	Dinkins et al	455:111
5,732,078	*	3/1998	Arango	370:355
5,757,783	*	5/1998	Eng et al	370:349
5,790,938	*	8/1998	Talarico	455:111

**OTHER PUBLICATIONS**

Franke, Michael S., "Packet Radios Provide Link for Distributed, Survivable CS in Post-Attack Scenarios," MSN Jun 1983

Lauer, Greg et al., "Communications in the Information Age," IEEE 1984, pp 1511-1514

Westcott, Jill A., "Issues in Distributed Routing for Mobile Packet Radio Network," IEEE 1982, pp 233-238

Westcott, Jill et al., "A Distributed Routing Design for a Broadcast Environment," IEEE 1982, pp 104-110 4-5

Kahn, Robert E., "Advances in Packet Radio Technology," IEEE Nov 1978, vol. 66, No. 11, pp 1468-1496

Kahn, Robert E., 'The Organization of Computer Resources into a Packet Radio Network,' IEEE Jan 1977, vol Com-25, No 1, pp 169-178

MacGregor, William et al., 'Multiple Control Stations in Packet Radio Network,' IEEE 1982, pp 103-110 3-5

Shacham, Nachum et al., 'Future Directions in Packet Radio Technology,' IEEE 1985, pp 93-98

Jubir, John, 'Current Packet Radio Network Protocols,' IEEE 1985, pp 86-92

Gower, Neil et al., 'Congestion Control Using Pacing in a Packet Radio Network,' IEEE 1982, pp 231-231-6

\* cited by examiner

*Primary Examiner*—Hvy D Vu

(74) *Attorney Agent, or Firm*—Oppenheimer Wolff & Donnelly LLP

(57) **ABSTRACT**

A wireless network system includes a server having a server controller and a server radio modem, and a number of clients each including a client controller and a client radio modem. The server controller implements a server process that includes the receipt and the transmission of data packets via the radio modem. The client controllers of each of the clients implements a client process that includes the receipt and transmission of data packets via the client radio modem. The client process of each of the clients initiates, selects, and maintains a radio transmission path to the server that is either a direct path to the server, or is an indirect path or "link" to the server through at least one of the remainder of the clients. A method for providing wireless network communication includes providing a server implementing a server process including receiving data packets via a radio modem, sending data packets via the server radio modem, communicating with the network, and performing house-keeping functions, and further includes providing a number of clients, each implementing a client process sending and receiving data packets via a client radio modem, maintaining a send/receive data buffer, and selecting a radio transmission path to the server. The radio transmission path or "link" is either a direct path to the server, or an indirect path to the server through at least one of the remainder of the clients. The process preferably optimizes the link to minimize the number of "hops" to the server.

**19 Claims, 42 Drawing Sheets**

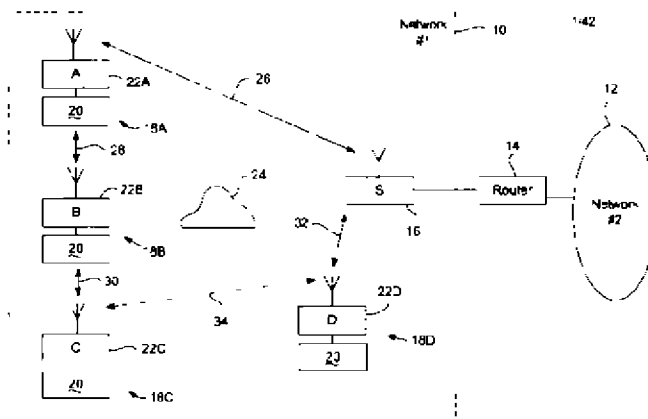

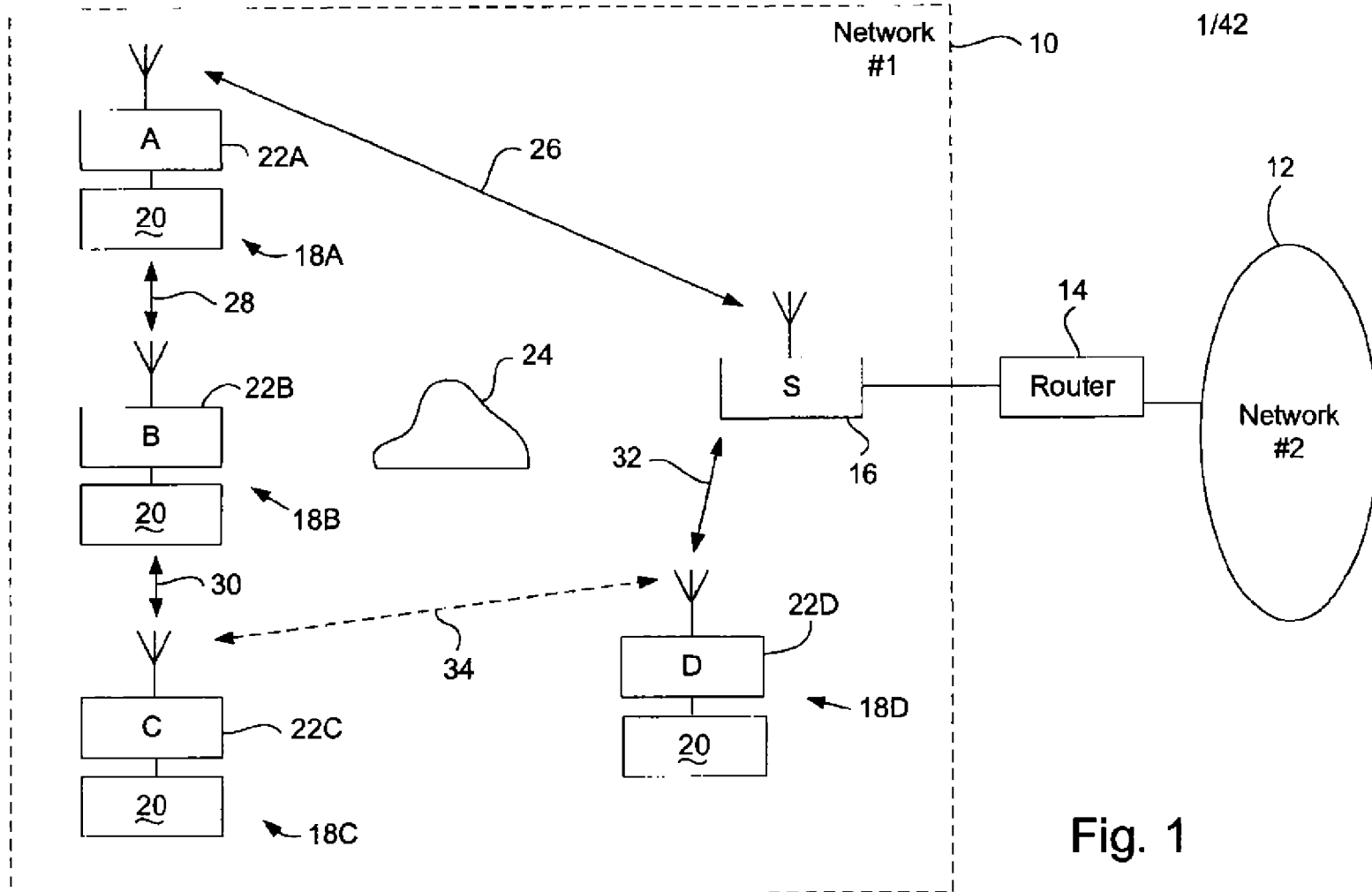
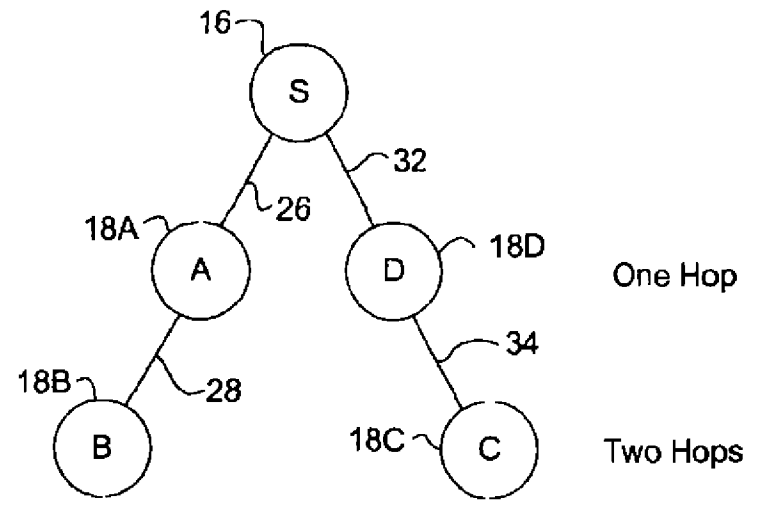
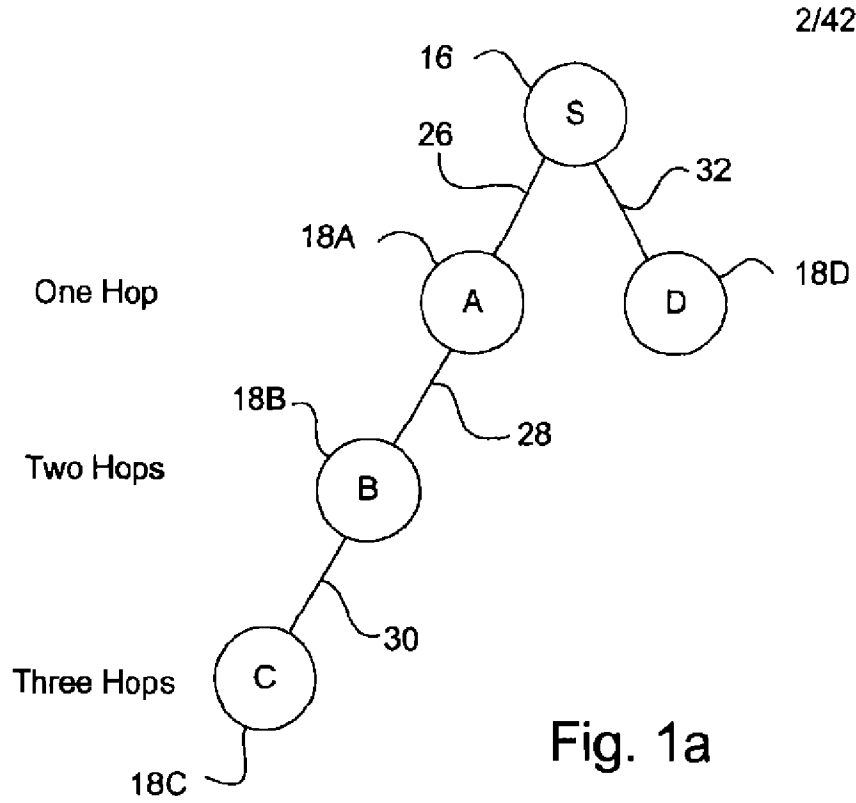

Fig. 1





**U.S. Patent**

Jun. 19, 2001

Sheet 3 of 42

**US 6,249,516 B1**

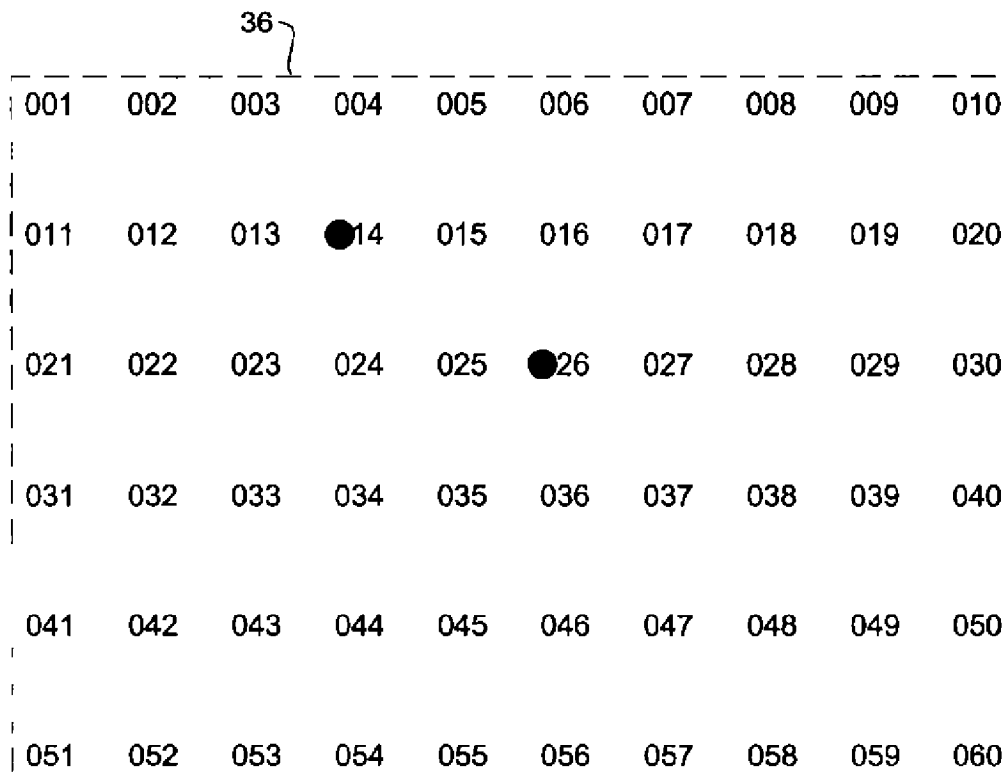
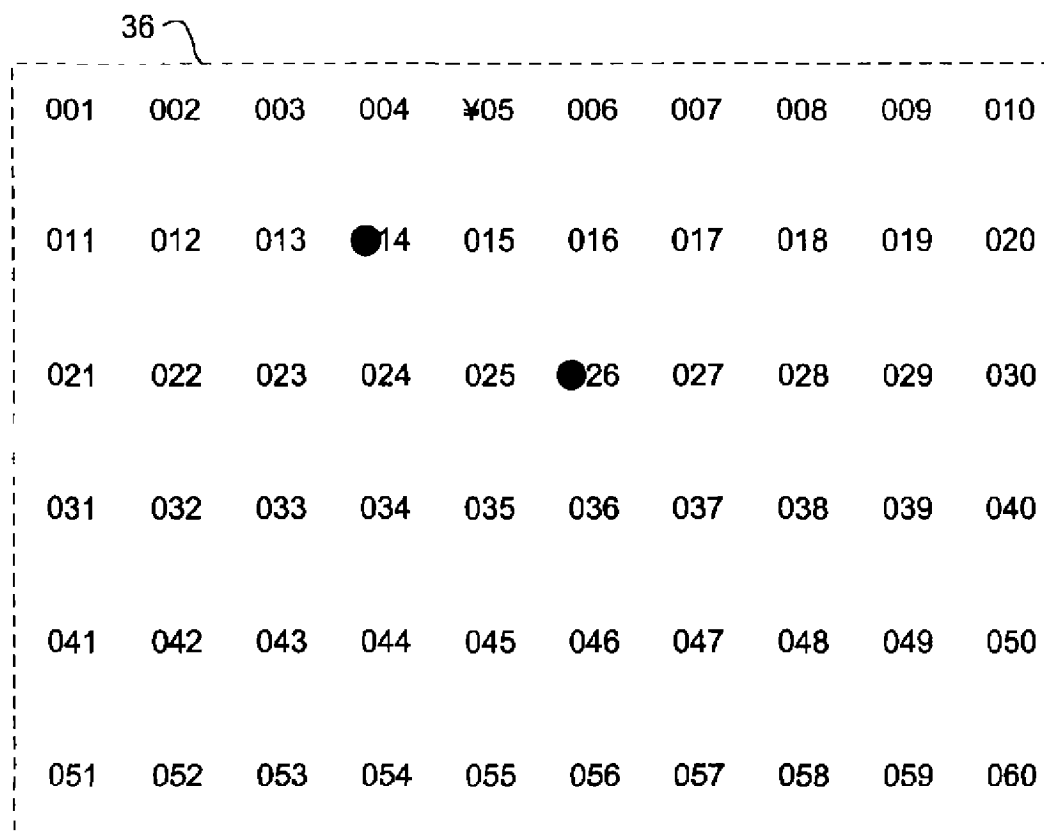

Fig. 2a

**U.S. Patent**

Jun. 19, 2001

Sheet 4 of 42

**US 6,249,516 B1**

There is only one Internet server in range of client 5.

5 will issue an "I am alive" packet seeking a route to the Internet

Internet server 14 will respond and add user client 5 to its routing table as its left son.

The updated routing table of Internet server 14 is 14(05).

The route from user client 5 to the Internet is 05>14

**Fig. 2b**

**U.S. Patent**

Jun. 19, 2001

Sheet 5 of 42

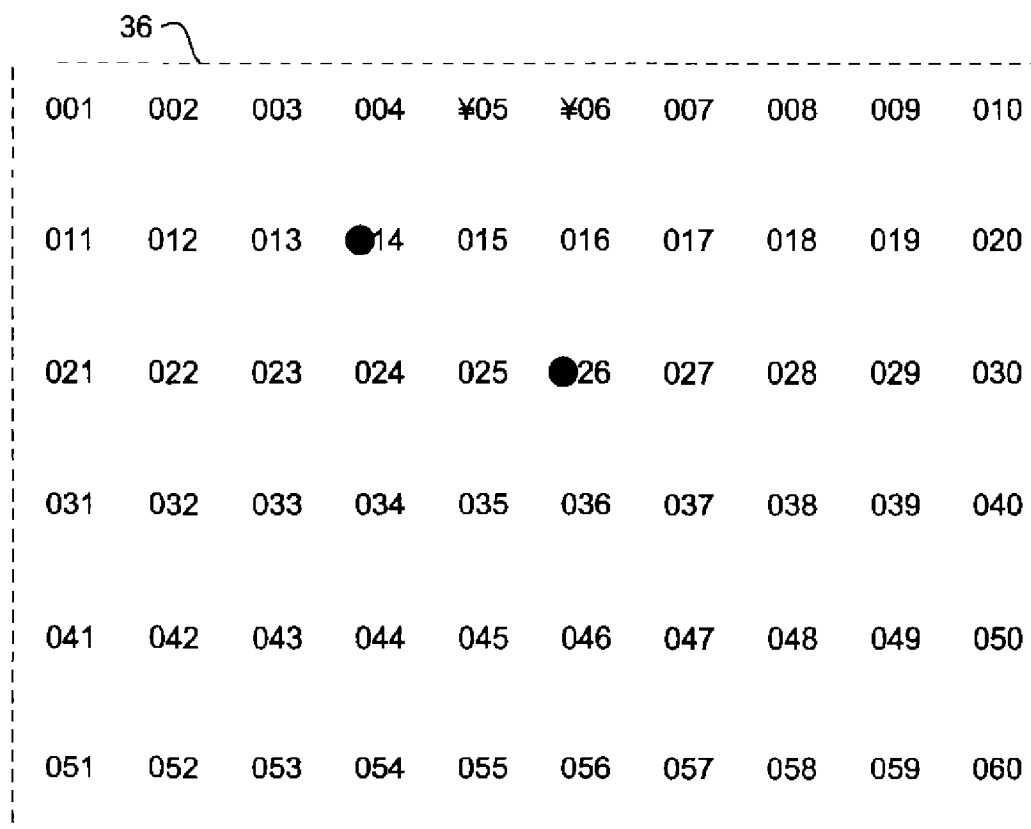
**US 6,249,516 B1**

There is only one user client in range of client 6

6 will issue an "I am alive" packet seeking a client repeater route to the Internet

5 will respond and add 6 to its routing table as its left son

The updated routing table of Internet server 14 is.  
14(05(06))

The route from user client 6 to the Internet is 06>05>14

**Fig. 2c**

**U.S. Patent**

Jun. 19, 2001

Sheet 6 of 42

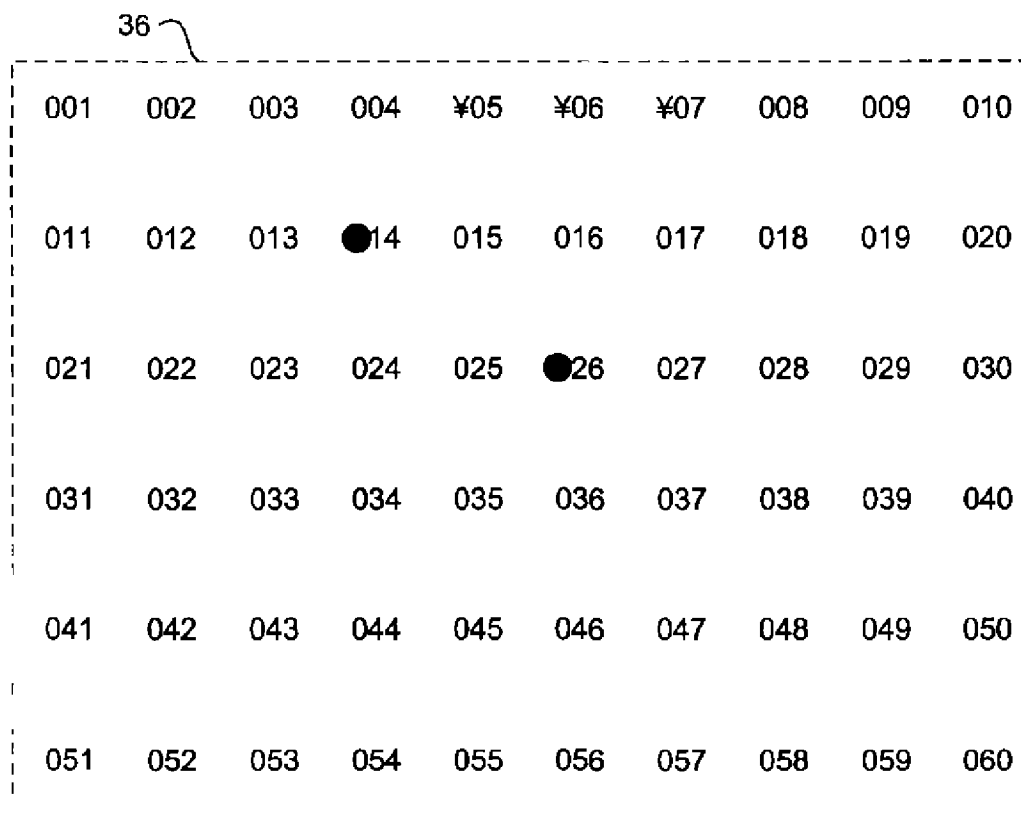
**US 6,249,516 B1**

There is only one user client in range of client 7

7 will issue an "I am alive" packet seeking a client repeater route to the Internet

6 will respond and add 7 to its routing table as its left son

The updated routing table of Internet server 14 is:  
14(05(06(07))).

The route from user client 7 to the Internet is: 07>06>05>14

**Fig. 2d**

**U.S. Patent**

Jun. 19, 2001

Sheet 7 of 42

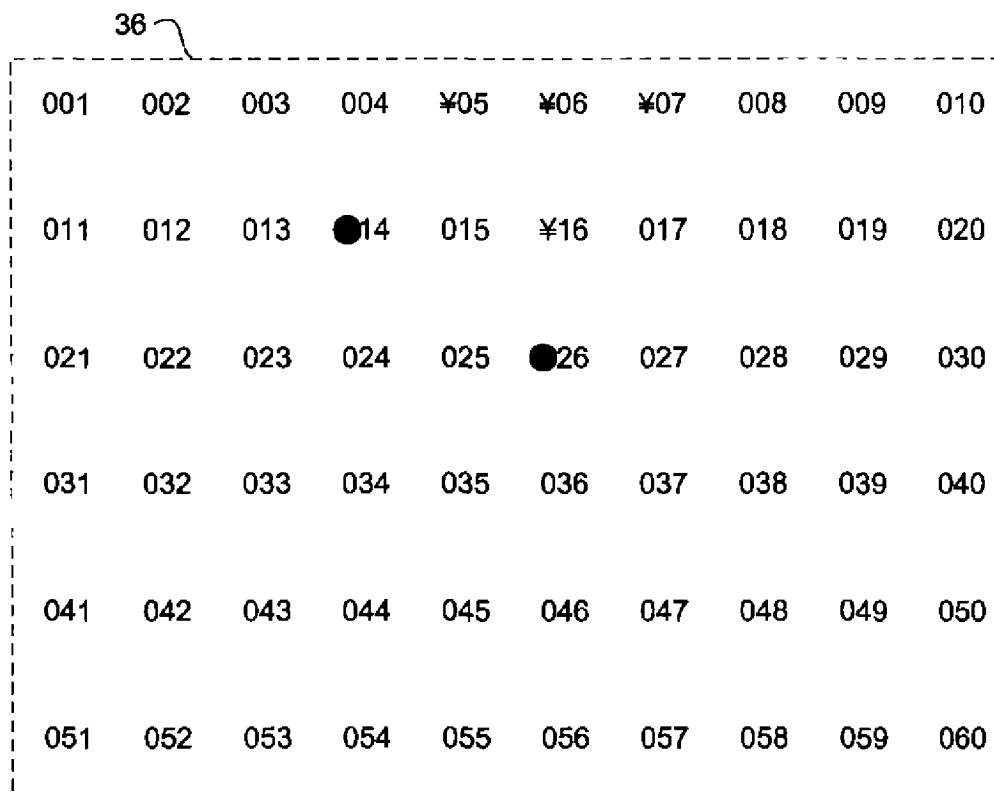
**US 6,249,516 B1**

There is only one Internet server in range of client 16

16 will issue an "I am alive" packet seeking a route to the Internet.

Internet server 26 will respond and add user client 16 to its routing table as its left son

The updated routing table of Internet server 26 is 26(16).

The route from user client 16 to the Internet is. 16>26

Fig. 2e

**U.S. Patent**

**Jun. 19, 2001**

**Sheet 8 of 42**

**US 6,249,516 B1**

Server 14 = 14(05(06))

Server 26 = 26(16(07))

Client 05 = 05(06); >14

Client 06 = 06; >05>14

Client 07 = 07; >16>26

Client 16 = 16(07); >26

In a universe of 6 nodes, of which 2 are servers, the average hop distance from a client to an Internet server is 1.5.

**Fig. 2f**

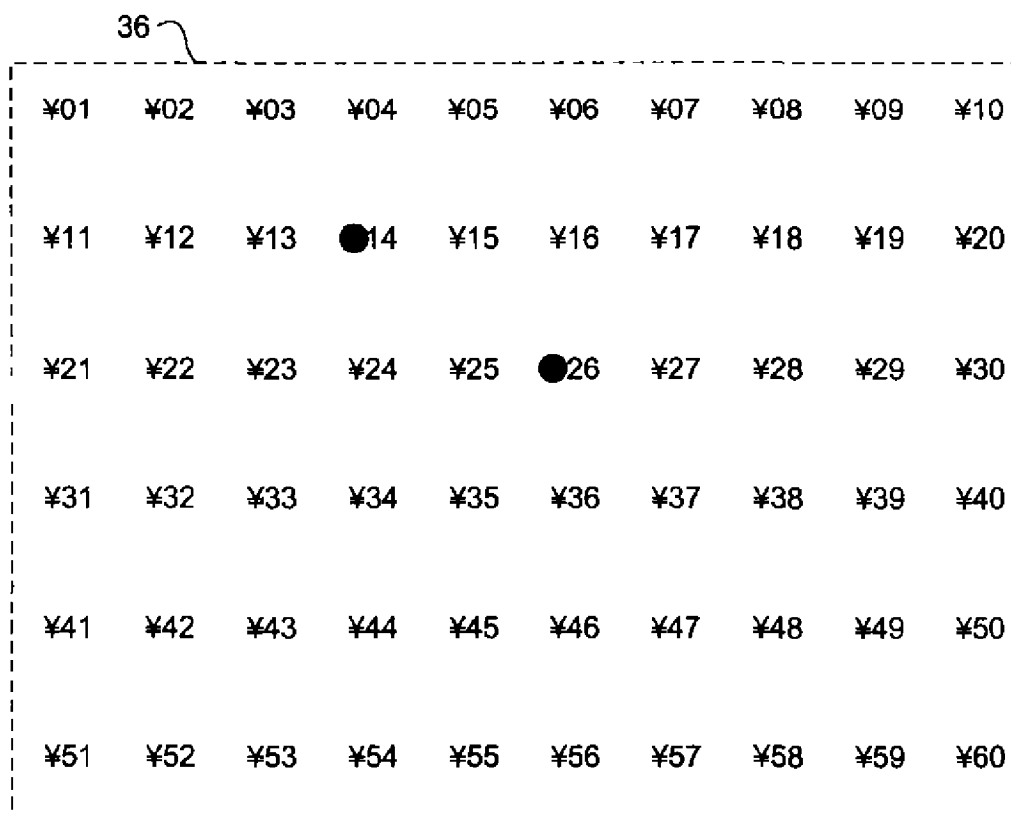

**Fig. 2g**



**U.S. Patent**

**Jun. 19, 2001**

**Sheet 10 of 42**

**US 6,249,516 B1**

Server 14 =

14(24(34),23(32(41(51),42(52)),33(43)),13(22(31)),05(06),  
04,03(02(11),12(01,21)))

Server 26 =

26(37(48(59(60),49(50),58),38(39(40)),28(29(30)),47(57)),  
36(46(56)),35(44(53,54),45(55)),27(18(19(20))),25,  
17(08(09(10)),07),16,15)

Client 01 = 01; >12>03>14

Client 02 = 02(11), >03>14

Client 03 = 03(02(11),12(01,21)); >14

Client 04 = 04; >14

Client 05 = 05(06); >14

Client 06 = 06; >05>14

Client 07 = 07; >17>26

Client 08 = 08(09(10)), >17>26

Client 09 = 09(10); >08>17>26

Client 10 = 10; >09>08>17>26

Client 11 = 11; >02>03>14

Client 12 = 12(01,21); >03>14

Client 13 = 13(22(31)); >14

Client 15 = 15; >26

Client 16 = 16, >26

Client 17 = 17(08(09(10)),07); >26

Client 18 = 18(19(20)), >27>26

Client 19 = 19(20), >18>27>26

Client 20 = 20; >19>18>27>26

Client 21 = 21, >12>03>14

Client 22 = 22(31); >13>14

Client 23 = 23(32(41(51),42(52)),33(43)); >14

Client 24 = 24(34); >14

Client 25 = 25; >26

Client 27 = 27(18(19(20))), >26

Client 28 = 28(29(30)),>37>26

Client 29 = 29(30);>28>37>26

Client 30 = 30,>29>28>37>26

Client 31 = 31;>22>13>14

**Fig. 2h'**

**U.S. Patent**

Jun. 19, 2001

Sheet 11 of 42

**US 6,249,516 B1**

Client 32 = 32(41(51),42(52)); >23>14  
Client 33 = 33(43);>23>14  
Client 34 = 34;>24>14  
Client 35 = 35(44(53,54),45(55));>26  
Client 36 = 36(46(56));>26  
Client 37 = 37(48(59(60),49(50),58),38(39(40)),  
28(29(30)),47(57));>26  
Client 38 = 38(39(40));>37>26  
Client 39 = 39(40);>38>37>26  
Client 40 = 40;>39>38>37>26  
Client 41 = 41(51);>32>23>14  
Client 42 = 42(52);>32>23>14  
Client 43 = 43;>33>23>14  
Client 44 = 44(53,54);>35>26  
Client 45 = 45(55);>35>26  
Client 46 = 46(56);>36>26  
Client 47 = 47(57);>37>26  
Client 48 = 48(59(60),49(50),58);>37>26  
Client 49 = 49(50);>48>37>26  
Client 50 = 50;>49>48>37>26  
Client 51 = 51;>41>32>23>14  
Client 52 = 52;>42>32>23>14  
Client 53 = 53;>44>35>26  
Client 54 = 54;>44>35>26  
Client 55 = 55;>45>35>26  
Client 56 = 56;>46>36>26  
Client 57 = 57;>47>37>26  
Client 58 = 58;>48>37>26  
Client 59 = 59(60);>48>37>26  
Client 60 = 60;>59>48>37>26

In a universe of 60 nodes, of which 2 are servers, the average hop distance from a client to an Internet server is 2 36206897.

**Fig. 2h"**

**U.S. Patent**

**Jun. 19, 2001**

**Sheet 12 of 42**

**US 6,249,516 B1**

Traversing user client universe

User client, 9, has 5 user client neighbors.

User client, 9, will probe each for the shortest route to the Internet.  
9's current route to the Internet is: nonexistent.

9 is now probing 10.

User client, 9, has no Internet server  
9's current route to the Internet is: nonexistent.

9 is now probing 20.

User client, 9, has no Internet server.  
9's current route to the Internet is: nonexistent.

9 is now probing 19.

User client, 9, has no Internet server.  
9's current route to the Internet is: nonexistent

9 is now probing 18.

User client, 9, has no Internet server.  
9's current route to the Internet is: nonexistent.

9 is now probing 8

User client 8 will add 9 to its routing table as its left son

The updated routing table of Internet server 14 is:  
14(05(06(07(08(09))))),04,03).

The route from user client 9 to the Internet is:  
09>08>07>06>05>14.

**Fig. 2i**

**U.S. Patent**

Jun. 19, 2001

Sheet 13 of 42

**US 6,249,516 B1**

Traversing user client universe .

User client, 29, has 8 user client neighbors.

User client, 29, will probe each for the shortest route to the Internet.  
29's current route to the Internet is: nonexistent.

29 is now probing 19

User client 19 will add 29 to its routing table as its left son.

The updated routing table of Internet server 14 is.

14(24,23,13,05(06(07(08(18(28),09(19(29),10(20)))))),  
04,03(12(22,21)))

The route from user client 29 to the Internet is:

29>19>09>08>07>06>05>14.

**Fig. 2j**

**U.S. Patent**

Jun. 19, 2001

Sheet 14 of 42

**US 6,249,516 B1**

Traversing user client universe . . .

User client, 7, has 5 user client neighbors.

User client, 7, will probe each for the shortest route to the Internet  
7's current route to the Internet is: 07>06>05>14

7 is now probing 8.

7's current route to the Internet is: 07>06>05>14

7 is now probing 18.

7's current route to the Internet is: 07>06>05>14

7 is now probing 17

User client, 7, has probed its neighbor, user client, 17, and found a shorter path to the Internet.

The old routing table of Internet server, 14, is.

14(24(34(44(54))),23(33(43(53))),13,05(06(07(08(18(28(38(48(58)))))),  
09(19(29(39(49(59))))),10(20(30(40(50(60)))))))))04,03(02,12(01,  
22(32(42(52))),21(31(41(51))))))

The updated routing table of Internet server, 26, is:

26(37(47(57)),36(46(56)),35(45(55)),27,25,17(07(08(18(28(38  
(48(58))))),09(19(29(39(49(59))))),10(20(30(40(50(60)))))))))16,15).

The route from user client, 7, to the Internet is: 07>17>26.

7's current route to the Internet is 07>17>26.

7 is now probing 16.

7's current route to the Internet is: 07>17>26.

7 is now probing 6.

7's final route is 07>17>26

**Fig. 2k**

Traversing user client universe . . .

User client, 8, has 5 user client neighbors.

User client, 8, will probe each for the shortest route to the Internet.  
8's current route to the Internet is 08>07>17>26.

8 is now probing 9.  
8's current route to the Internet is: 08>07>17>26

8 is now probing 19.  
8's current route to the Internet is. 08>07>17>26

8 is now probing 18.  
8's current route to the Internet is. 08>07>17>26.

8 is now probing 17.  
User client, 8, has probed its neighbor, user client, 17, and found a shorter path to the Internet.

The old routing table of Internet server, 26, is.  
26(37(47(57)),36(46(56)),35(45(55)),27,25,17(07(08(18(28(38(48(58))))),09(19(29(39(49(59))))),10(20(30(40(50(60))))))))) ,16,15).

The updated routing table of Internet server, 26, is  
26(37(47(57)),36(46(56)),35(45(55)),27,25,17(08(18(28(38(48(58))))),09(19(29(39(49(59))))),10(20(30(40(50(60))))))))) ,07,16,15).

The route from user client, 8, to the Internet is 08>17>26.  
8's current route to the Internet is: 08>17>26.

8 is now probing 7.  
8's final route is 08>17>26.

**Fig. 2I**

**U.S. Patent**

Jun. 19, 2001

Sheet 16 of 42

**US 6,249,516 B1**

Traversing user client universe .

User client, 18, has 8 user client neighbors

User client, 18, will probe each for the shortest route to the Internet.  
18's current route to the Internet is: 18>08>17>26.

18 is now probing 8

18's current route to the Internet is 18>08>17>26

18 is now probing 9.

18's current route to the Internet is: 18>08>17>26.

18 is now probing 19.

18's current route to the Internet is: 18>08>17>26.

18 is now probing 29.

18's current route to the Internet is: 18>08>17>26

18 is now probing 28.

18's current route to the Internet is: 18>08>17>26.

18 is now probing 27.

User client, 18, has probed its neighbor, user client, 27, and found a shorter path to the Internet

The old routing table of Internet server, 26, is.

26(37(47(57)),36(46(56)),35(45(55)),27,25,17(08(18(28(38(48(58))))),09(19(29(39(49(59))))),10(20(30(40(50(60))))))))) ,07),16,15)

The updated routing table of Internet server, 26, is

26(37(47(57)),36(46(56)),35(45(55)),27(18(28(38(48(58))))),25,17(08(09(19(29(39(49(59))))),10(20(30(40(50(60))))))))) ,07),16,15).

The route from user client, 18, to the Internet is: 18>27>26.

18's current route to the Internet is 18>27>26.

18 is now probing . . .

18's final route is 18>27>26.

**Fig. 2m**

User client, 29, has 8 user client neighbors

User client, 29, will probe each for the shortest route to the Internet  
29's current route to the Internet is 29>19>18>27>26

29 is now probing 19  
29's current route to the Internet is 29>19>18>27>26.

29 is now probing 20  
29's current route to the Internet is: 29>19>18>27>26.

29 is now probing 30.  
29's current route to the Internet is: 29>19>18>27>26

29 is now probing 40  
29's current route to the Internet is: 29>19>18>27>26.

29 is now probing 39.  
29's current route to the Internet is 29>19>18>27>26.

29 is now probing 38.  
29's current route to the Internet is: 29>19>18>27>26

29 is now probing 28.  
User client, 29, has probed its neighbor, user client, 28, and found a shorter path to the Internet  
The old routing table of Internet server, 26, is.  
26(37(28(38(48(58))),47(57)),36(46(56)),35(45(55)),27(18(19(20(30(40(50(60))))),29(39(49(59)))))),25,17(08(09(10)),07),16,15)

The updated routing table of Internet server, 26, is:  
26(37(28(29(39(49(59))),38(48(58))),47(57)),36(46(56)),35(45(55)),27(18(19(20(30(40(50(60)))))),25,17(08(09(10)),07),16,15).

The route from user client, 29, to the Internet is' 29>28>37>26.  
29's current route to the Internet is. 29>28>37>26.

29 is now probing 18.  
29's final route is 29>28>37>26.

**Fig. 2n**



Traversing user client universe . . .

User client, 44, has 8 user client neighbors.

User client, 44, will probe each for the shortest route to the Internet  
44's current route to the Internet is: 44>34>24>14.

44 is now probing 34

44's current route to the Internet is: 44>34>24>14

44 is now probing 35

User client, 44, has probed its neighbor, user client, 35, and found a shorter path to the Internet.

The old routing table of Internet server, 14, is:

14(24(34(44(54))),23(32(41(51),42(52)),33(43(53))),13(22(31)),  
05(06),04,03(02,12(01(11),21))).

The updated routing table of Internet server, 14, is:

14(24(34),23(32(41(51),42(52)),33(43(53))),13(22(31)),05(06),04,  
03(02,12(01(11),21))).

The updated routing table of Internet server, 26, is:

26(37(38(39(40(50(60)),49(59)),48(58)),28(29(30)),47(57)),36(46  
(56)),35(44(54),45(55)),27(18(19(20))),25,17(08(09(10)),07),16,15).

The route from user client, 44, to the Internet is: 44>35>26

44's current route to the Internet is: 44>28>37>26.

44 is now probing . . .

.

.

44's final route is 44>35>26.

**Fig. 2o**

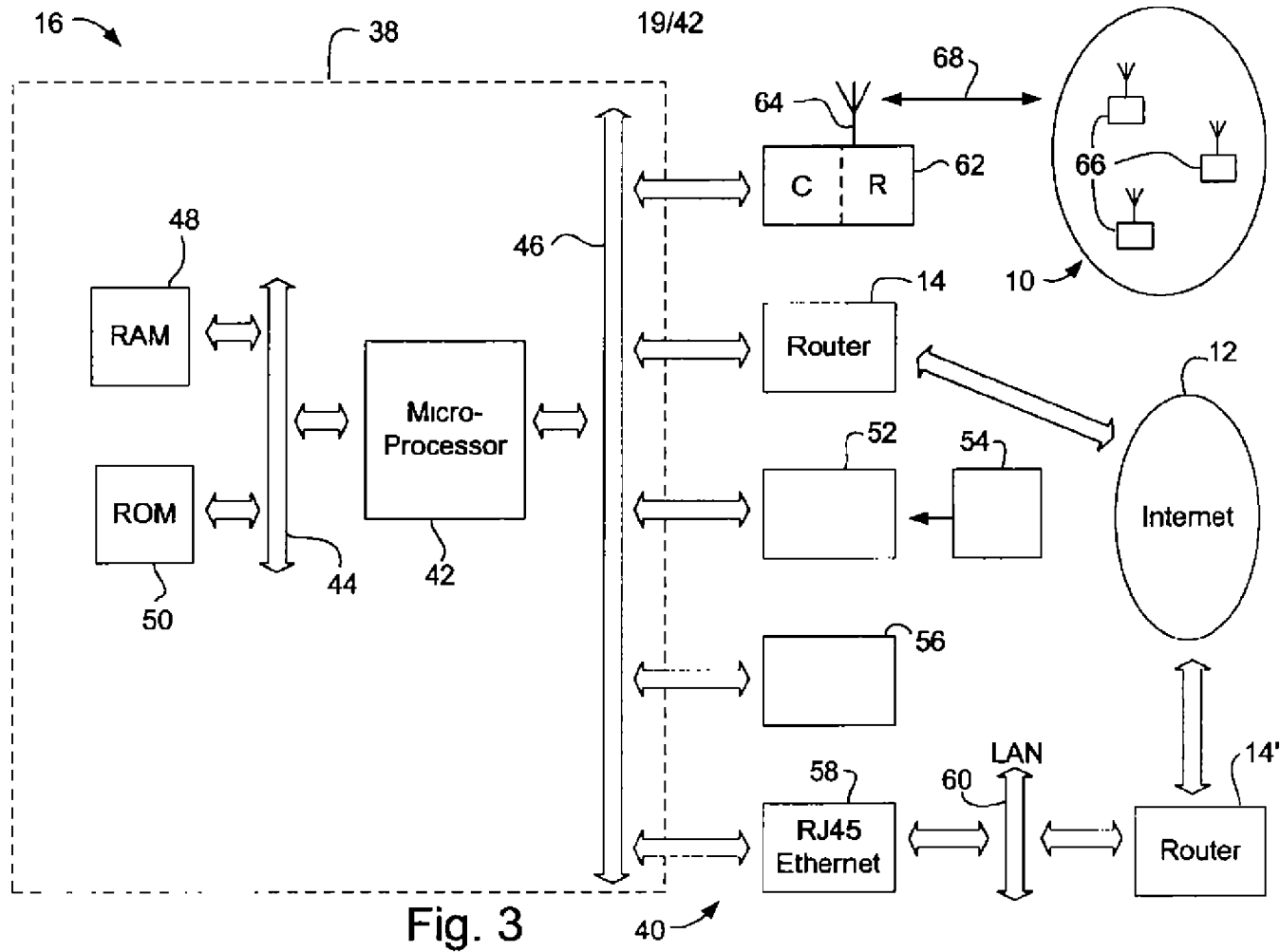

Fig. 3

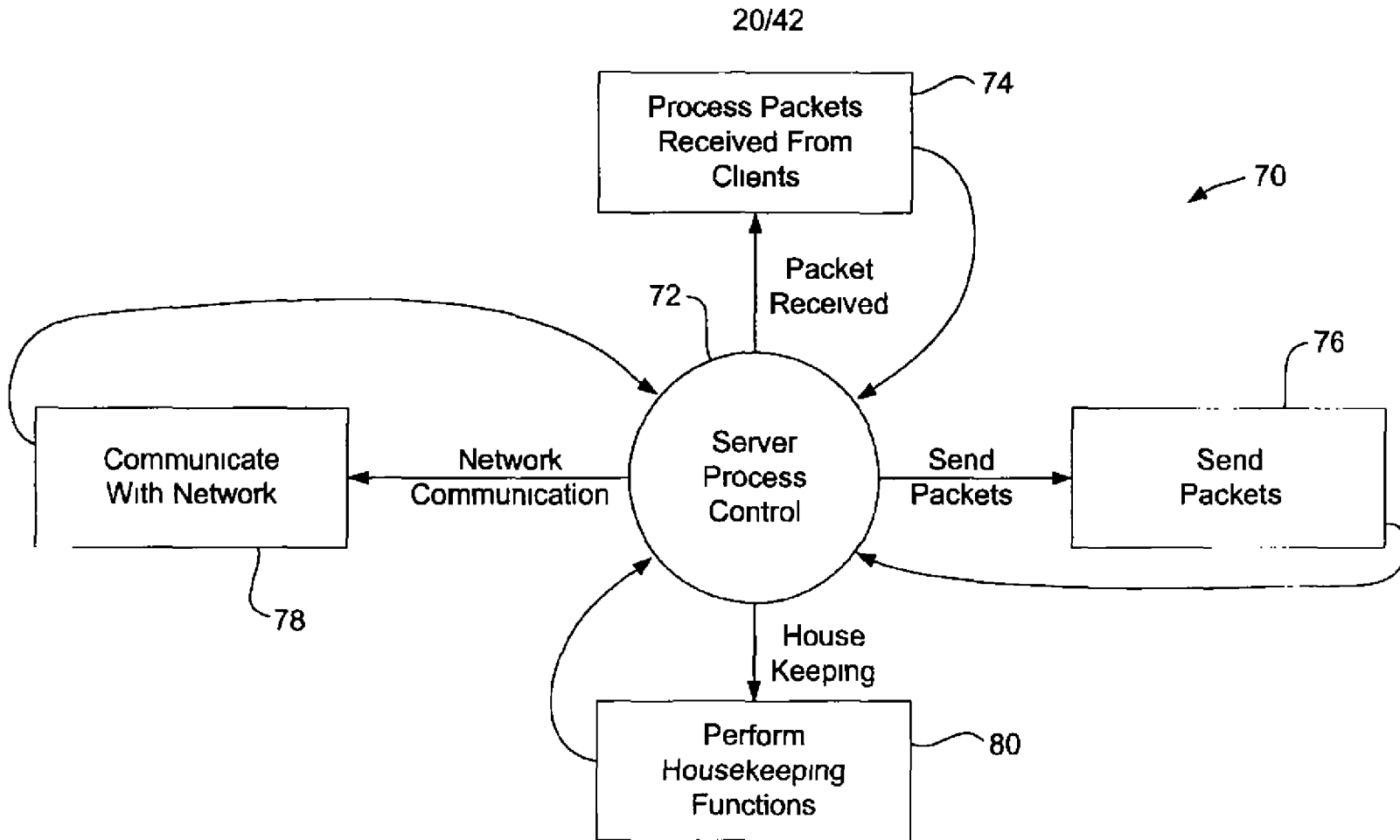

Fig. 4

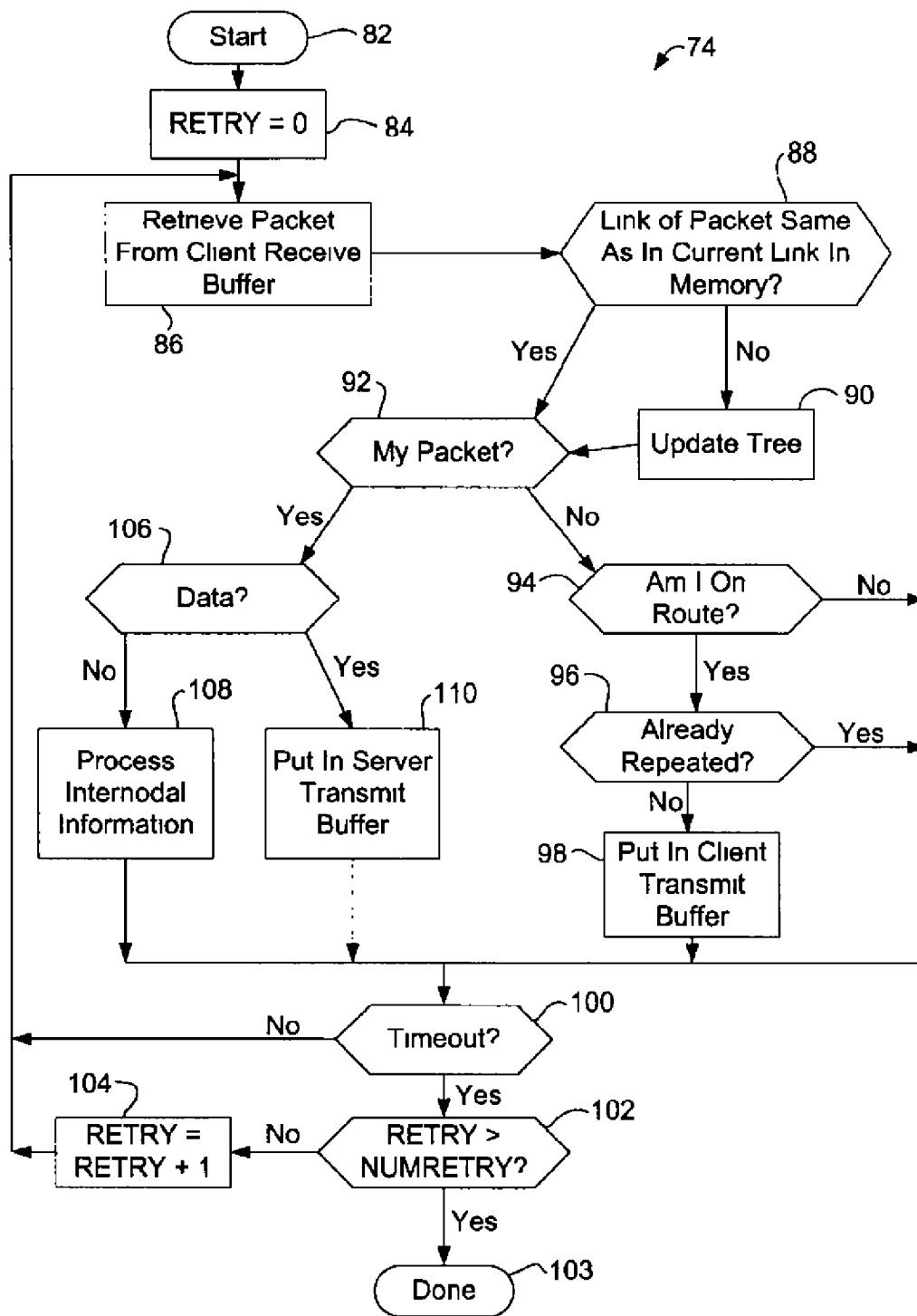

Fig. 5

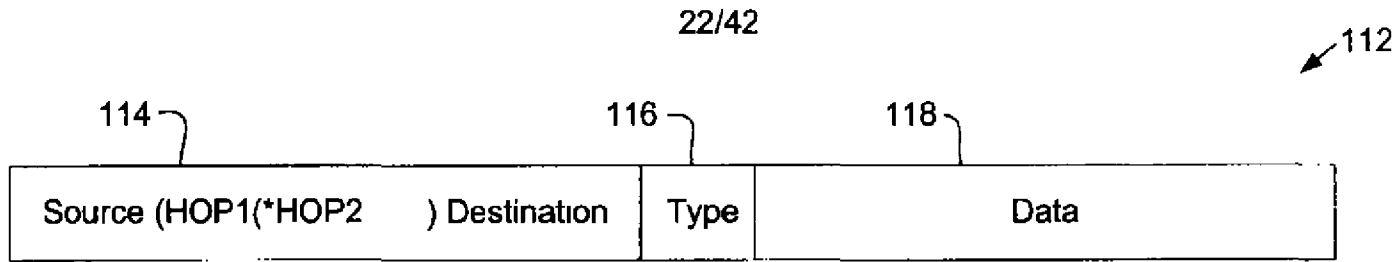

Fig. 5a

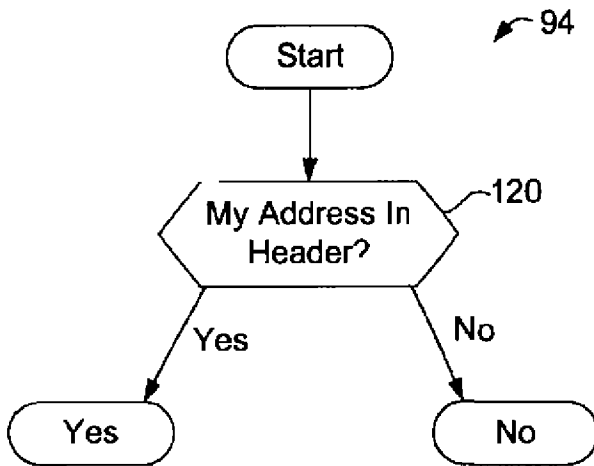

Fig. 5b

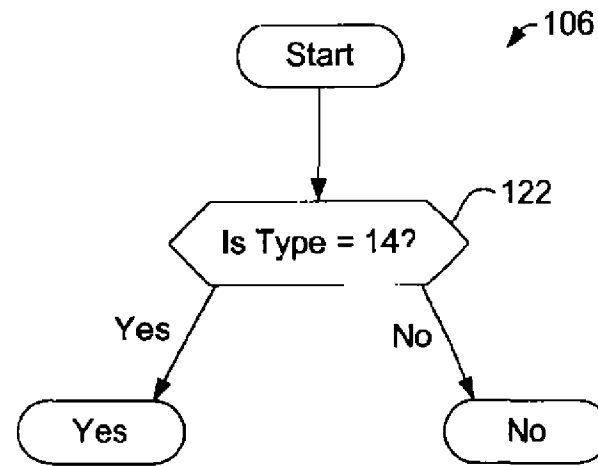

Fig. 5c

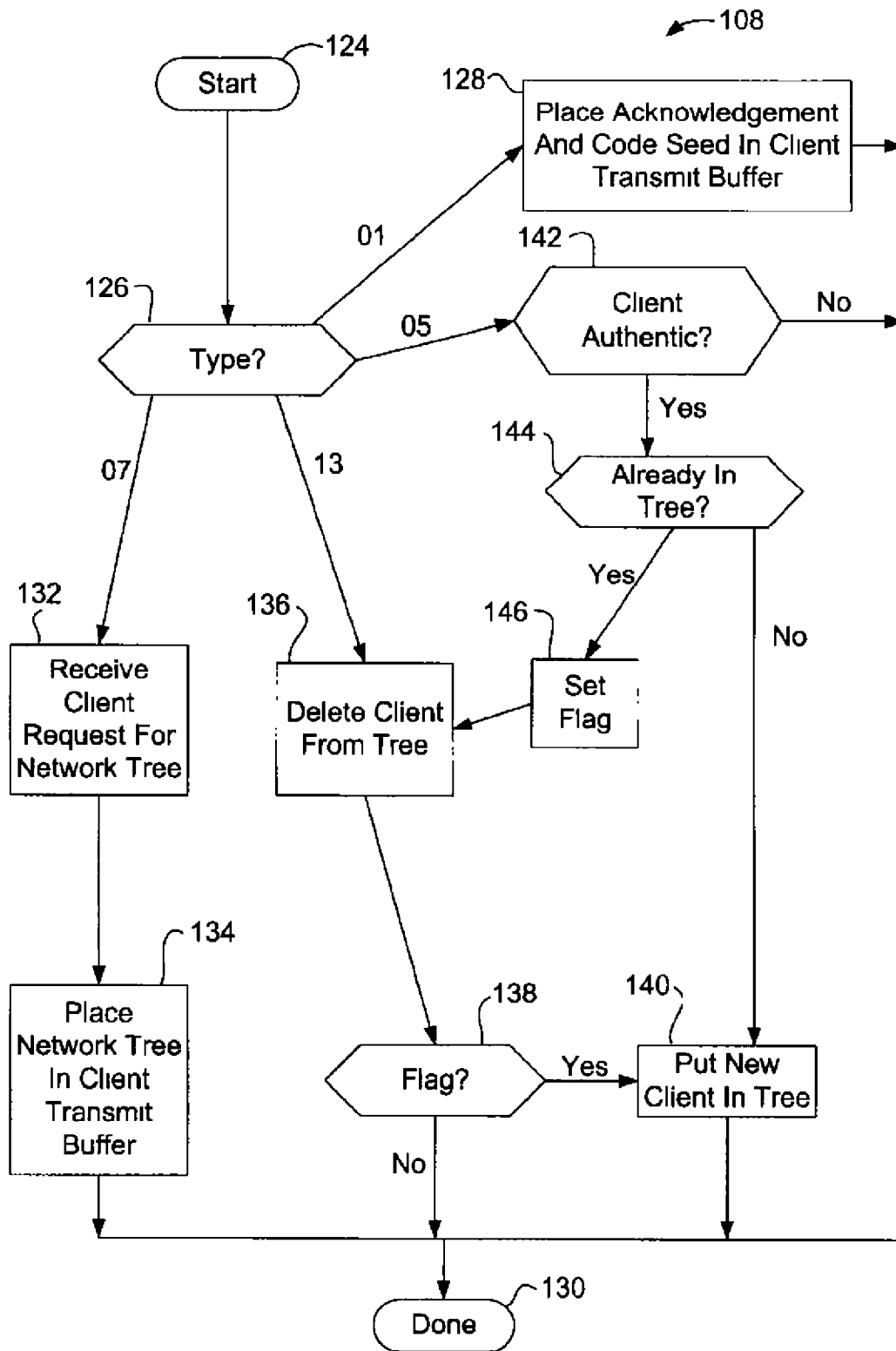

Fig. 6

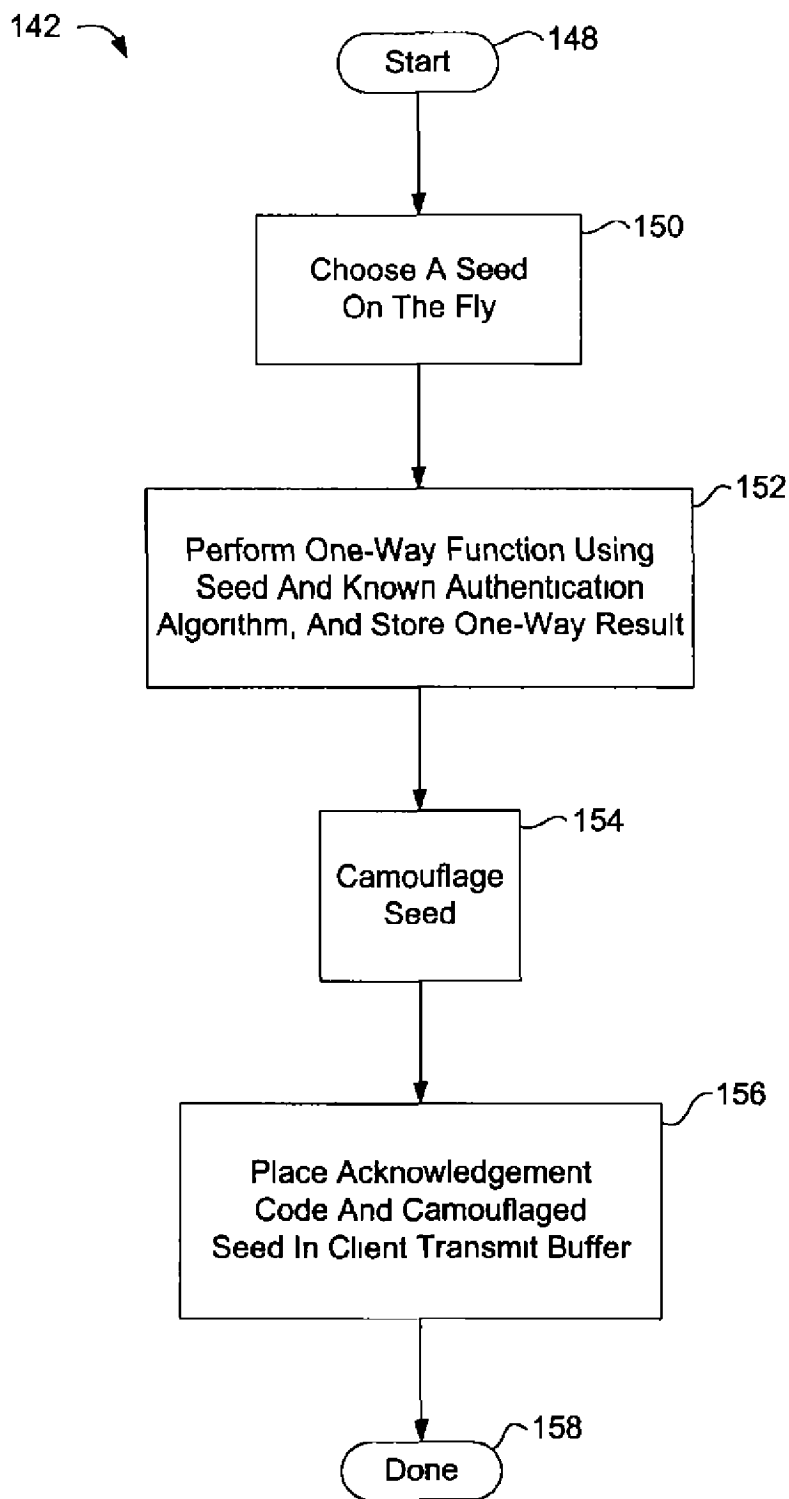

Fig. 6a

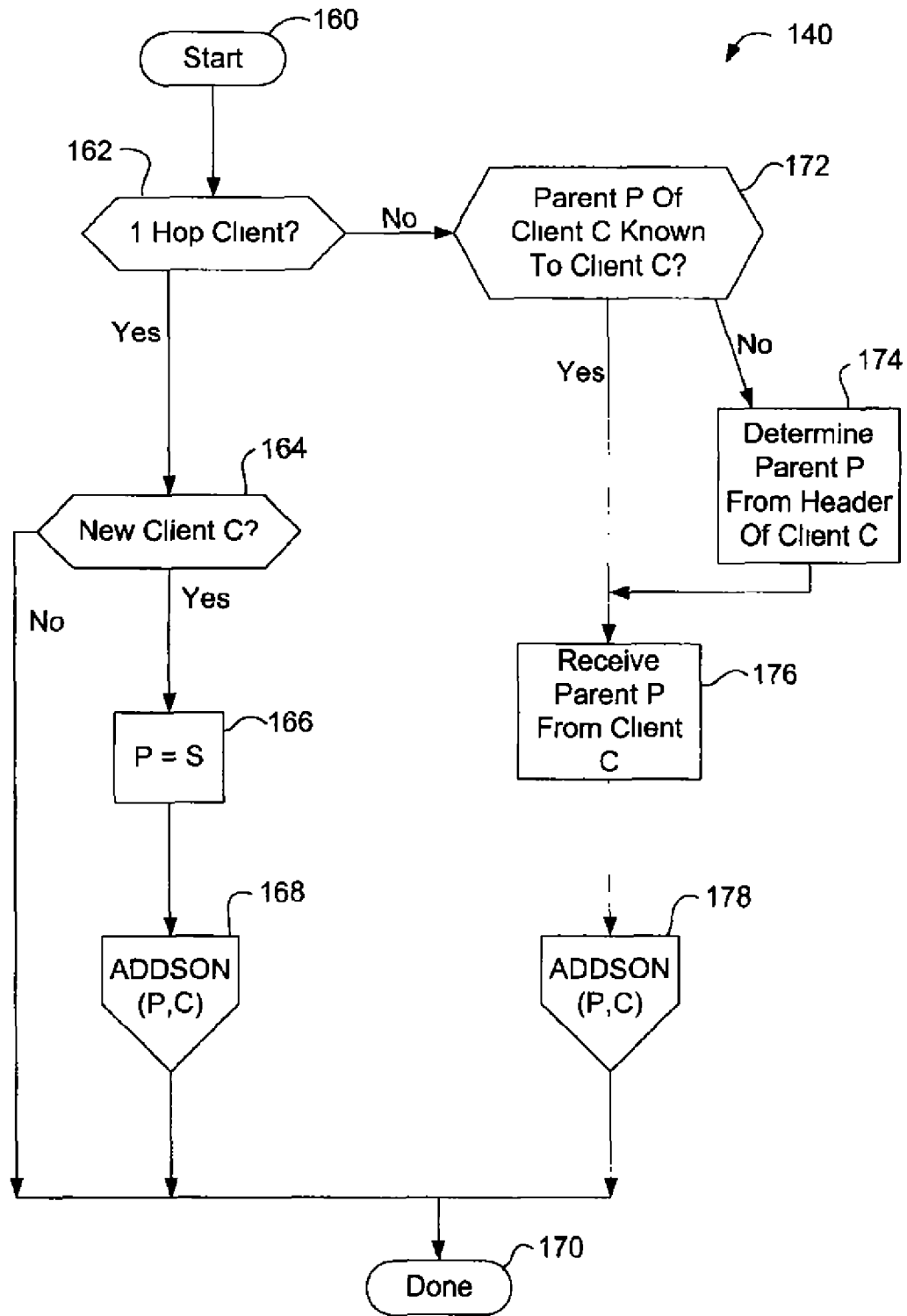

Fig. 6b



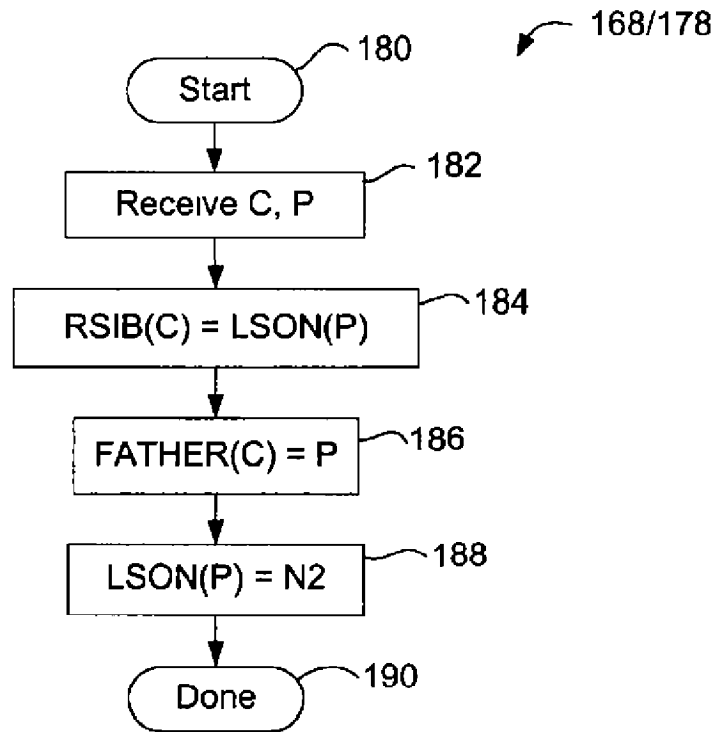

Fig. 7

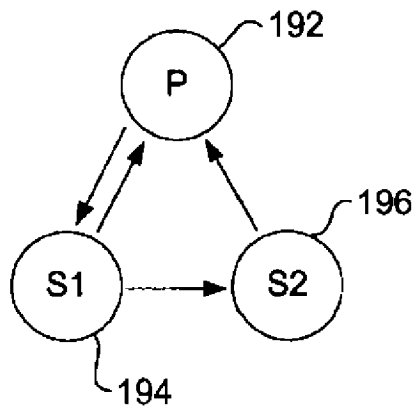

Fig. 7a

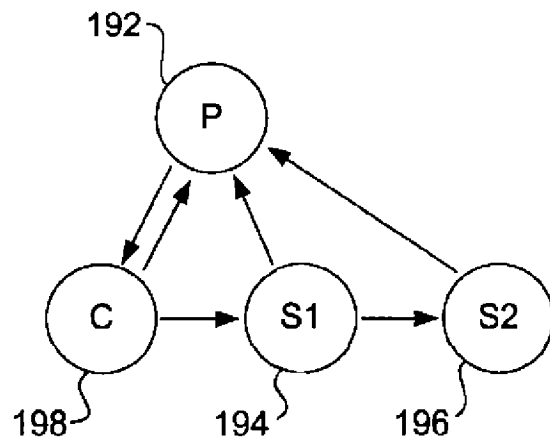

Fig. 7b

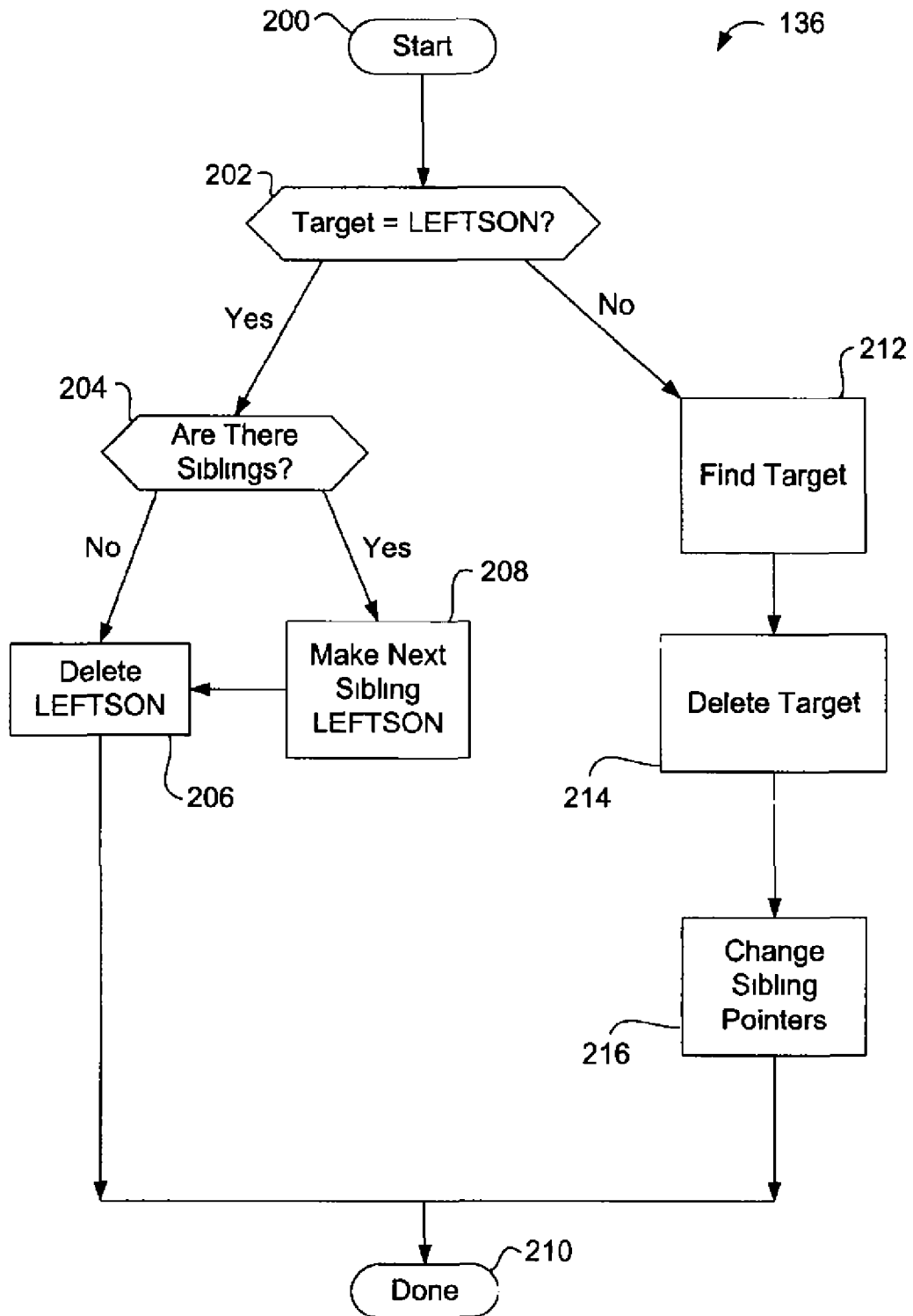

Fig. 8