

FILED

Wh

IN THE UNITED STATES DISTRICT COURT  
FOR THE MIDDLE DISTRICT OF FLORIDA  
ORLANDO DIVISION

03 DEC -5 PM 2: 51

CLERK OF DISTRICT COURT  
MIDDLE DISTRICT OF FLORIDA  
ORLANDO, FLORIDA

LAUGHLIN PRODUCTS, INC., §  
§  
Plaintiff, §  
§  
v. §  
§  
BERNICE W. ANDERSON, §  
d/b/a Tiki Tanning, §  
§  
Defendant. §

CIVIL ACTION NO. 6:03cv1743-DN-19 KRS

**ORIGINAL COMPLAINT**

Plaintiff, LAUGHLIN PRODUCTS, INC., alleges:

1. This is an action for patent infringement, brought under the patent laws of the United States, 35 U.S.C. § 271 *et seq.*

**PARTIES**

2. Plaintiff, Laughlin Products, Inc., is a Texas corporation having its principal place of business at 3506 Blueberry Hill, Grapevine, Texas 76051.

3. Defendant, Bernice W. Anderson, d/b/a Tiki Tanning, is an individual doing business at 4119 Neptune Road, St. Coud, Florida 34769, where she can be served.

**JURISDICTION AND VENUE**

4. This is an action for patent infringement brought under the patent laws of the United States, 35 U.S.C. § 271 *et seq.* Jurisdiction of the patent infringement claims is conferred on this Court under 28 U.S.C. §§ 1331 and 1338 (a).

5. This Court has personal jurisdiction over Defendant under Fed. R. Civ. P. 4 (k) (1)

1

(A).

6. Venue is proper in this district under 28 U.S.C. § 1391 in that the unlawful activities herein alleged were performed in whole or in part in this district and in that Defendant resides in and does business in this district.

COUNT ONE - PATENT INFRINGEMENT of U.S. PATENT NO. 5,922,333

7. Plaintiff is the owner of U.S. Patent No. 5,922,333 (“the ‘333 patent”) titled “System for Automatically Coating the Human Body.” The ‘333 patent describes and claims a system for spray applying self-tanning solutions and other compositions onto the human body. Plaintiff licenses others to manufacture and sell the system of the ‘333 patent to businesses and individuals. A true and correct copy of the ‘333 patent is attached hereto as Exhibit A.

8. On information and belief, Defendant operates within this district a system for spray applying self-tanning solutions and other compositions onto the human body (“The System”). Defendant’s use of The System constitutes infringement of the ‘333 patent under 35 U.S.C. § 271.

9. Plaintiff has suffered damages as a direct result of Defendant’s infringement. Under 35 U.S.C. § 284, Plaintiff is entitled to damages adequate to compensate for the infringement, including lost profits, but not less than a reasonable royalty.

10. On information and belief, Defendant’s infringement of the ‘333 patent is willful. Plaintiff is therefore entitled to enhanced damages under 35 U.S.C. § 284. Plaintiff also requests that the Court hold this to be an exceptional case.

COUNT TWO - PATENT INFRINGEMENT of U.S. PATENT NO. 6,298,862

11. Plaintiff is the owner of U.S. Patent No. 6,298,862 (“the ‘862 patent”) titled “Method of and Apparatus for Automatically Coating the Human Body: Fogging Technology.” The ‘862

patent describes and claims a method and apparatus for spray applying self-tanning solutions and other compositions onto the human body. Plaintiff licenses others to manufacture and sell the system of the '862 patent to businesses and individuals. A true and correct copy of the '862 patent is attached hereto as Exhibit B.

12. On information and belief, Defendant operates within this district a system for spray applying self-tanning solutions and other compositions onto the human body ("The System"). Defendant's use of The System constitutes infringement of the '862 patent under 35 U.S.C. § 271.

13. Plaintiff has suffered damages as a direct result of Defendant's infringement. Under 35 U.S.C. § 284, Plaintiff is entitled to damages adequate to compensate for the infringement, including lost profits, but not less than a reasonable royalty.

14. On information and belief, Defendant's infringement of the '862 patent is willful. Plaintiff is therefore entitled to enhanced damages under 35 U.S.C. § 284. Plaintiff also requests that the Court hold this to be an exceptional case.

**COUNT THREE - PATENT INFRINGEMENT of U.S. PATENT NO. 6,474,343**

15. Plaintiff is the owner of U.S. Patent No. 6,474,343 ("the '343 patent") titled "Method of and Apparatus for Automatically Coating the Human Body." The '343 patent describes and claims a method and apparatus for spray applying self-tanning solutions and other compositions onto the human body. Plaintiff licenses others to manufacture and sell the system of the '343 patent to businesses and individuals. A true and correct copy of the '343 patent is attached hereto as Exhibit C.

16. On information and belief, Defendant operates within this district a system for spray applying self-tanning solutions and other compositions onto the human body ("The System").

Defendant's use of The System constitutes infringement of the '343 patent under 35 U.S.C. § 271.

17. Plaintiff has suffered damages as a direct result of Defendant's infringement. Under 35 U.S.C. § 284, Plaintiff is entitled to damages adequate to compensate for the infringement, including lost profits, but not less than a reasonable royalty.

18. On information and belief, Defendant's infringement of the '343 patent is willful. Plaintiff is therefore entitled to enhanced damages under 35 U.S.C. § 284. Plaintiff also requests that the Court hold this to be an exceptional case.

#### COUNT FOUR - INJUNCTIVE RELIEF

19. Plaintiff reasserts the foregoing paragraphs 7 through 18.

20. Plaintiff will be irreparably harmed if Defendant's patent infringement continues. The balance of equities favors a preliminary injunction in favor of Plaintiff. Plaintiff therefore requests a preliminary injunction prohibiting Defendant and anyone else in active concert with her, from using the system or taking any other actions that would infringe the '333, the '862, or the '343 patent.

#### JURY DEMAND

21. Plaintiff requests a jury trial of all issues in this action so triable.

WHEREFORE, Plaintiff respectfully requests that this Court enter a judgment:

- A. that Defendant has infringed the '333 patent;
- B. that Defendant has infringed the '862 patent;
- C. that Defendant has infringed the '343 patent;
- D. entering a preliminary and, ultimately, a permanent injunction as requested above restraining Defendant and anyone else in active concert with her, from using the

infringing system or taking any other actions that would directly or indirectly infringe the '333, the '862, or the '343 patent;

- E. entering an award of enhanced damages under 35 U.S.C. § 284;
- F. that this case is exceptional, and that Plaintiff therefore recover reasonable costs, expenses, and attorney's fees, under 35 U.S.C. § 285;
- F. that Plaintiff recover such other and further relief as this court may deem appropriate.

Dated: \_\_\_\_\_

*12/4/03*

By: \_\_\_\_\_

*[Handwritten Signature]*

John W. Bolanovich, Esq.  
BOGIN, MUNNS & MUNNS  
2601 Technology Drive  
P.O. Box 2807  
Orlando, Florida 32804  
Phone: 407/578-1334  
Fax: 407/578-2347

*[Handwritten Signature]*

Michael A. O'Neil  
State Bar No. 15285000  
Kevin Nash  
State Bar No. 14811100  
Justin B. Kimble  
State Bar No. 24036909  
Michael A. O'Neil, P.C.  
5949 Sherry Lane, Suite 820  
Dallas, Texas 75225  
(214) 739-0088 (telephone)  
(214) 739-8284 (fax)



US005922333A

**United States Patent** [19]  
**Laughlin**

[11] **Patent Number:** **5,922,333**  
[45] **Date of Patent:** **Jul. 13, 1999**

- [54] **SYSTEM FOR AUTOMATICALLY COATING THE HUMAN BODY**
- [75] **Inventor:** Thomas J. Laughlin, Grapevine, Tex.
- [73] **Assignee:** Laughlin Products, Inc., Grapevine, Tex.
- [21] **Appl. No.:** 08/946,764
- [22] **Filed:** Oct. 8, 1997

**Related U.S. Application Data**

- [60] Provisional application No. 60/039,489, Feb. 28, 1997, and provisional application No. 60/052,498, Jul. 14, 1997.
- [51] **Int. Cl.<sup>6</sup>** ..... A61K 6/00; A61K 7/00; A61K 7/42; A61K 31/74
- [52] **U.S. Cl.** ..... 424/401; 424/59; 424/78.02; 424/78.03; 424/78.06
- [58] **Field of Search** ..... 424/59, 78.02, 424/78.03, 78.06, 401, 62, 405, 63, 404; 426/72; 514/847, 906, 919, 886, 887

**References Cited**

**U.S. PATENT DOCUMENTS**

3,932,151	1/1976	Lau	.....	55/229
4,231,289	11/1980	Domicent	.....	98/115 SB
4,832,943	5/1989	Grollier et al.	.....	424/59
5,089,269	2/1992	Noda et al.	.....	424/456
5,102,660	4/1992	Forestier et al.	.....	424/401
5,153,174	10/1992	Band et al.	.....	514/12
5,268,166	12/1993	Barnett et al.	.....	424/47

**FOREIGN PATENT DOCUMENTS**

WO 94/12146 6/1994 WIPO ..... A61K 7/021

**OTHER PUBLICATIONS**

Non-Carcinogenicity of Dihydroxyacetone by Skin Painting, Frank J. Akin & Edward Marlowe, *Journal of Environmental Pathology and Toxicology*, 5:No. 5, pp. 349-351, 1984.  
 Color Additive: Dihydroxyacetone, *Federal Register*, 38: No. 148, p. 20615, Aug. 2, 1973.  
 Theory & Practice of Artificial Tanning Literature & Patent Survey, E. Futterer, *Cosmetics and perfumes*, 88:No. 8, pp. 31-33, 1973.  
 Persistence of Skin Color and Fluorescence after Treatment with Dihydroxyacetone, J. A. Johnson & R. M. Fusaro, *Dermatology* 188: pp. 247, 1994.  
 Formulating Effective Self-Tanners with DHA, T. Kurz, *Cosmetics and Toiletries*, 109: No. 11, pp. 55-60, 1994.  
 Dihydroxyacetone-containing sunless or self-tanning lotions, Stanley B. Levy, *Journal of the American Academy of Dermatology*, 27:No. 6, pp. 989-993, 1992.  
*Spray Application Processes*, Binks Training Division, TD49-2R-4, Aug. 1995.

*Primary Examiner*—Thurman K. Page  
*Assistant Examiner*—Sharon Howard  
*Attorney, Agent, or Firm*—Michael A. O'Neil

**ABSTRACT**

[57] In a system for coating human skin, a chemical composition, such as a cosmetic or medical formulation, is uniformly coated over the entire body or selected parts of the body of the person being coated. The system includes atomization of the coating composition, containment of the atomized spray, and residual recovery which together yield a novel method for applying chemical compositions.

**40 Claims, 4 Drawing Sheets**

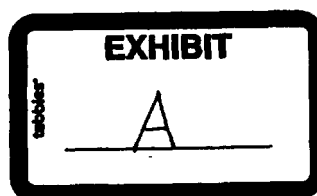
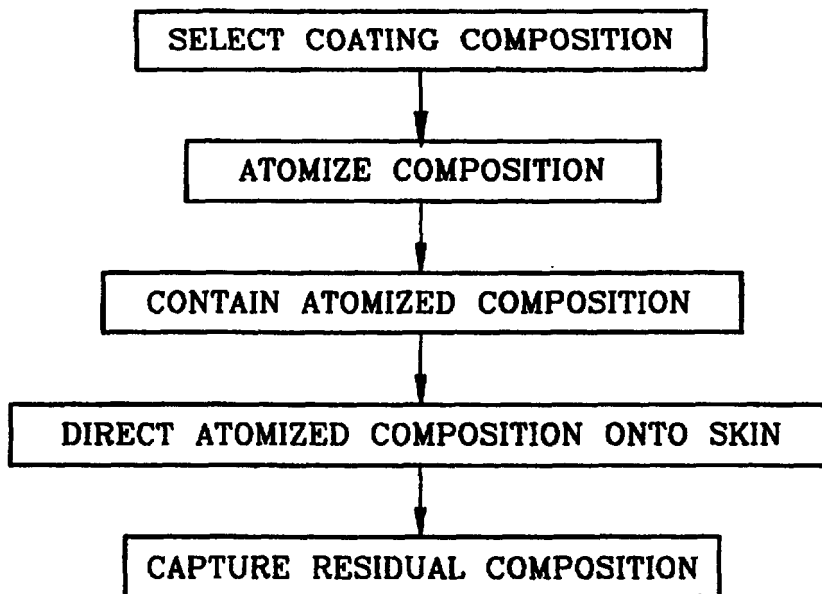

U.S. Patent

Jul. 13, 1999

Sheet 1 of 4

5,922,333

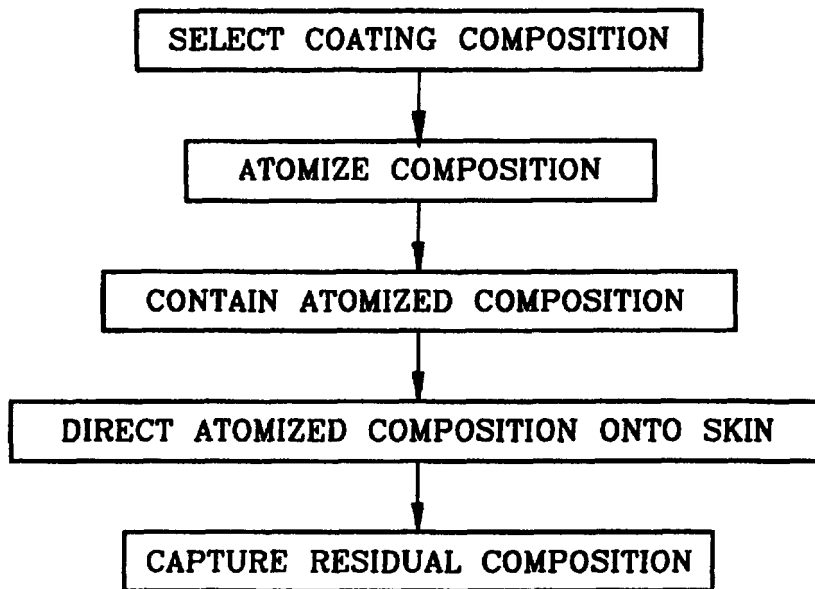

FIG. 1

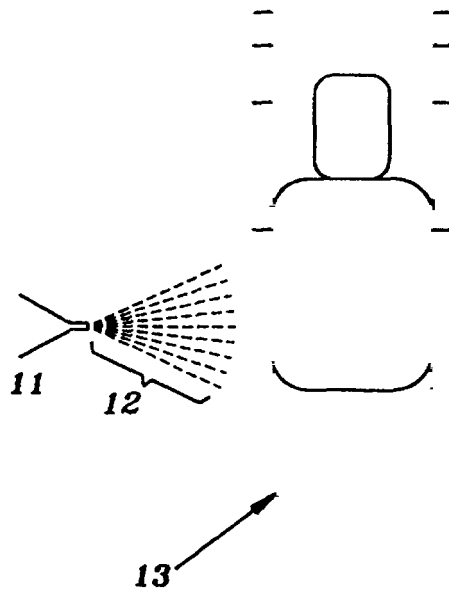

FIG. 2

U.S. Patent

Jul. 13, 1999

Sheet 2 of 4

5,922,333

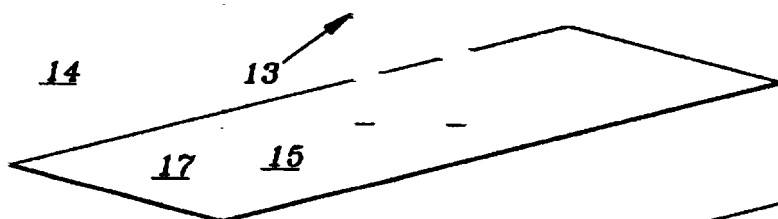
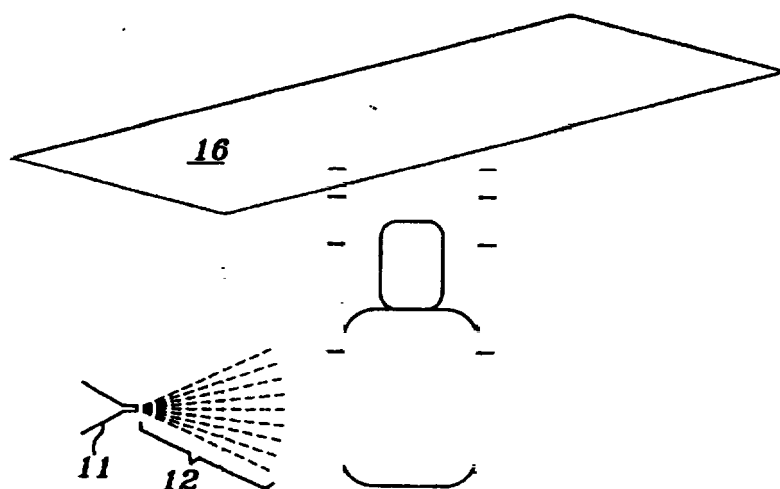

FIG. 3

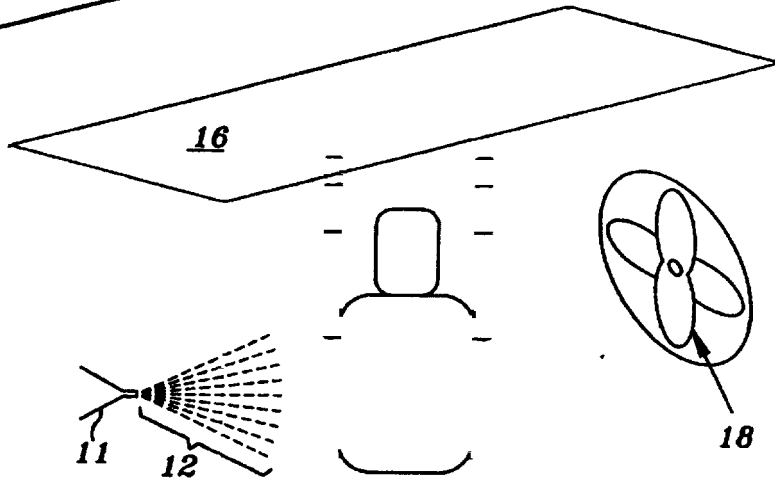
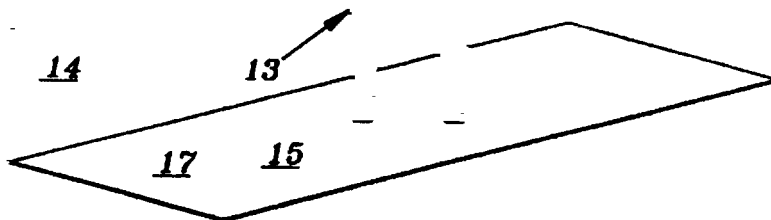

FIG. 4





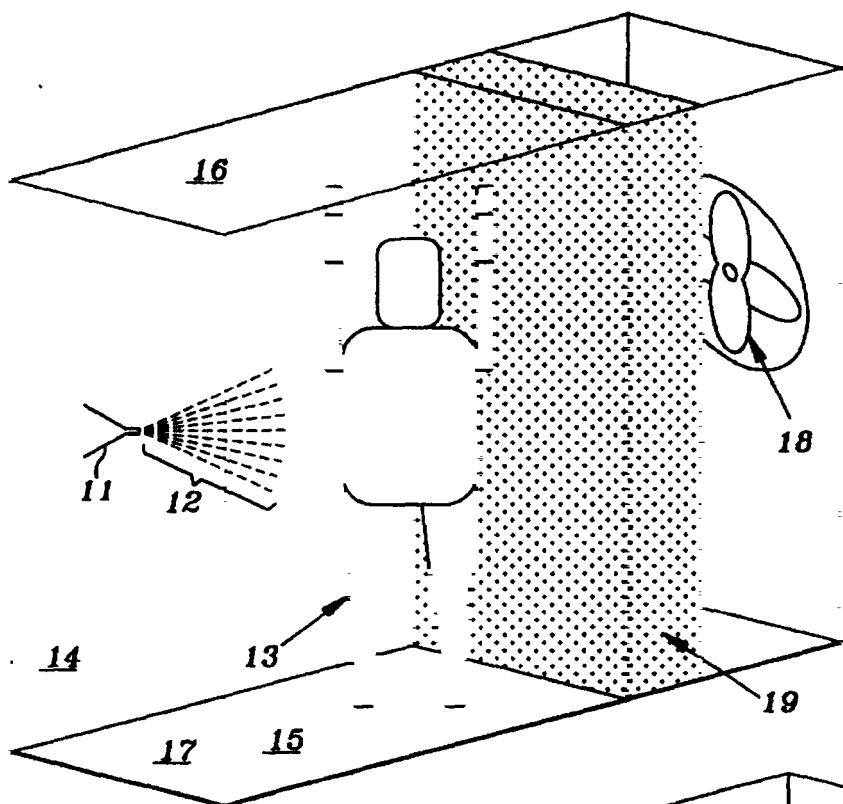

FIG. 5

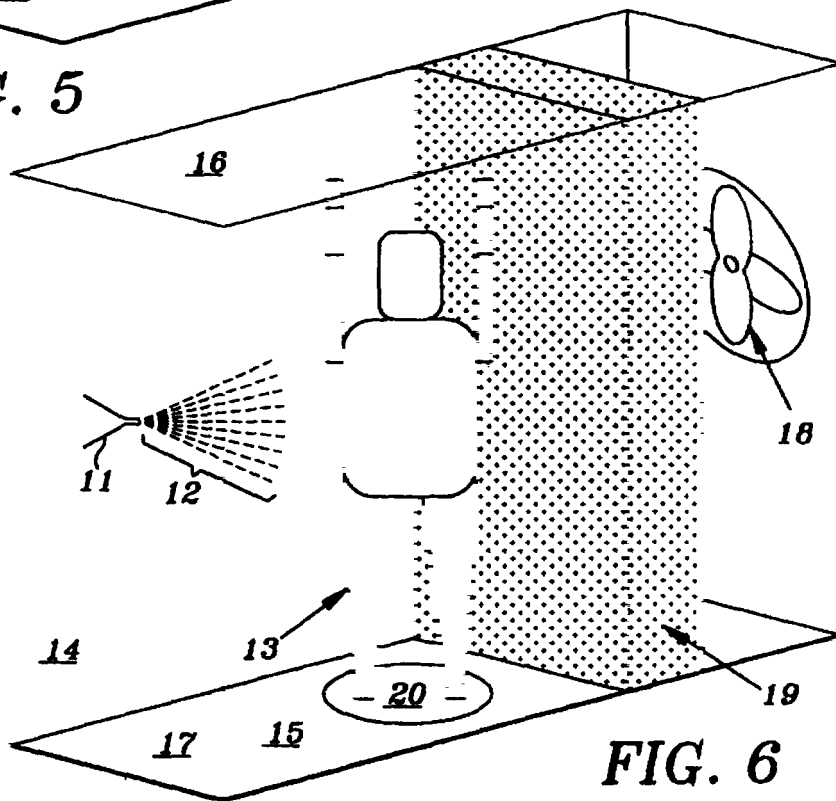

FIG. 6

U.S. Patent

Jul. 13, 1999

Sheet 4 of 4

5,922,333

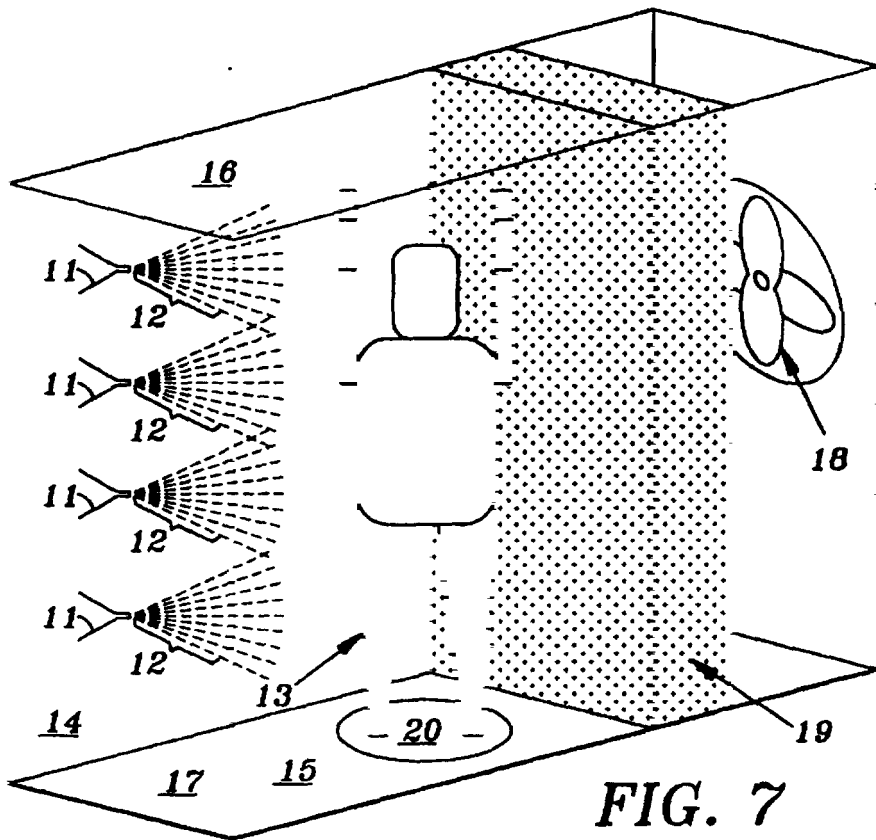

FIG. 7

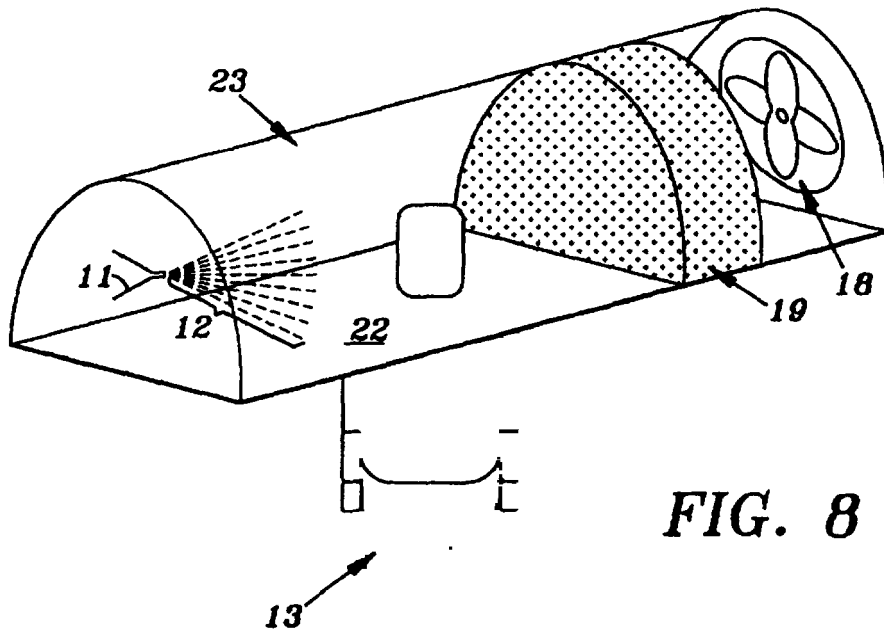

FIG. 8

5,922,333

1

**SYSTEM FOR AUTOMATICALLY COATING  
THE HUMAN BODY**

**RELATED APPLICATIONS**

This application claims priority from Provisional Application Ser. No. 60/039,489 filed on Feb. 28, 1997, and No. 60/052,498 filed on Jul. 14, 1997.

**TECHNICAL FIELD**

The present invention relates generally to systems for automatically coating the human body or selected parts thereof with predetermined fluids. More particularly, the invention relates to an automated self-tanning system.

**BACKGROUND OF THE INVENTION**

The application of various fluids to all or selected parts of the human body has been known literally for centuries. However, despite the long standing and wide spread practice of coating the human body with various fluids, there has never been a successful way of automatically coating the human body. Therefore, prior to the present invention, it has been necessary to apply fluids to the body manually.

Manual application of fluids to the human body results in numerous disadvantages. First, it is almost impossible to uniformly coat the human body with fluids using manual application techniques. This is true even in the case of fluids that are provided in aerosol or spray form because such fluids must be rubbed in after application. Second, the application of fluids to certain parts of the human body, for example, the back, require the availability of an assistant in order that proper manual application can be attempted.

The foregoing difficulties are particularly apparent in the case of artificial tanning processes. Artificial tanning has been known for more than 40 years, with artificial tanning products appearing on the U.S. market as early as 1959. The two key types of tanning processes are by colorants and bronzers.

Tanning by colorants is based on the color reaction which occurs between components of the skin and the colorant. The most commonly used chemical for artificial tanning is dihydroxyacetone (DHA). It is widely used in commercial artificial tanning products, and is recognized as safe and effective by the U.S. Food and Drug Administration (FDA). DHA reacts solely with the stratum corneum. It interacts with amines, peptides and free amino acids to generate a Maillard reaction. The resulting products are cyclic and linear polymers that have a yellow or brown color.

Two common bronzers are juglone and lawsone. Both are naphthoquinones. When applied to skin, lawsone produces an orange hue and juglone produces a greenish-brown tan. They are sometimes used in combination with DHA to modify the color or hue of the tan or to intensify the color.

Numerous forms of artificial tanning products are now on the market. They include:

- lotions,
- creams,
- gels,
- oils,
- sprays.

These products are mixtures of a chemically-active skin colorant or a bronzer with combinations of the following:

- moisturizers,
- preservatives,

2

- antimicrobials,
- thickeners,
- solvents,
- emulsifiers,
- 5 fragrances,
- surfactants,
- stabilizers,
- sun-screens,
- 10 pH adjusters
- anti-caking agents,
- ingredients to alter the color reaction.
- 15 Users of these products often experience significant problems associated with the current methods for applying artificial tanning formations to skin. These problems include the following.
- If not properly dried, the formulation will streak or form blotches with time. The net result is a very non-uniform tan, with light or dark streaks or blotches.
- 20 Certain parts of the body will stain more intensely when the formulation is spread manually. This differential staining is due to enhance absorption of certain skin tissue and the tendency of certain tissue to retain more formulation. The result is that as the formulation is being spread manually, certain tissue absorb or trap more formulation (e.g., the wrinkles in the elbows and knees and the dense tissue in the palms).
- Most products designed for manual application require components such as thickeners and polymers, which often inhibit the efficacy of DHA.
- Current formulations typically take about 20 minutes to dry to the touch, and about 1 hour before not transferring from skin to textiles.
- Application of artificial tanning products is additionally complicated by the tendency of these formulations to stain materials containing amine molecules, including certain fabrics, certain types of carpet, and certain wall coverings and paint.
- 25 In spite of all of these problems, artificial tanning is becoming increasingly popular. It is apparent that a need exists for a superior application system which solves the foregoing problems.
- There is also a need for a superior applications system for many other applications, including but not limited to:
- self-tanning formulations,
- sunscreens,
- suntan lotions,
- 30 tanning accelerators,
- sunburn treatments,
- insect repellants,
- skin toners,
- skin bleaches,
- skin lighteners,
- anti-microbial compositions,
- moisturizers,
- 35 exfoliants,
- nutriments or vitamins,
- massage aides,
- muscle relaxants,
- skin treatment agents,
- burn treatment agents,
- 40 decontamination agents,

5,922,333

3

cosmetics,

wrinkle treatments or removers.

There are specific and significant problems with the manual coating of each of these products. The artificial tanning application provides a good illustration of the types of problems normally encountered when manually coating these products. Artificial tanning is also one of the most demanding applications in that uniformity of the coating is critical to assure uniform tanning.

#### SUMMARY OF THE INVENTION

The present invention comprises a system for automatically coating the human body, including a method of and apparatus for uniformly and rapidly coating all or selected parts of the human body. The system includes apparatus which atomizes (also referred to as aerosolization, nebulization, mist generation, fog generation or spray generation) a chemical composition and deposits it uniformly over all or selected parts of the human body. It is not necessary for the individual receiving the treatment nor anyone else to manually apply any of the formulation. Also, a containment system is provided which restrains and collects residue from the application process. The system can optionally recycle the materials used.

There are several major advantages resulting from the use of the invention:

- Uniform application minimizes or eliminates streaking,
- No assistant is required for applying the composition,
- The entire skin surface receives the same exposure to the composition, so the uniformity of the coating is greatly enhanced over manual application,
- The optimal formulation for atomization is very simple, and does not require the addition of components which may inhibit the efficacy of the applied material,
- The application time can be as quick as a few seconds, and complete drying can occur in just a few minutes,
- The containment system drastically reduces the unwanted environmental impact,
- Multiple applications can be used to better control the amount of material applied per unit area, and additional substances can be applied in separate applications.

#### REFERENCES

- U.S. patent documents
- 3,932,151 1/1976 Lau 55/229
- 4,231,289 11/1980 Domicent 98/115
- 5,268,166 12/1993 Barnett 424/047
- Foreign patent documents
- WO 94/12146 6/1994 PCT Int'l Appl.
- Other publications
- Akins, F. J. and Marlowe, E., "Non-Carcinogenicity of Dihydroxyacetone by Skin Painting," *Journal of Environmental Pathology and Toxicology*, 5: No. 5, pp. 349-351 (1984).
- Federal Register, "Color Additive Dihydroxyacetone" 38: No. 148, p. 21615, Aug. 2, 1973.
- Futterer, E., "Theory and Practice of Artificial Tanning: Literature and Patent Survey," *Cosmetics and Perfumes*, 88: No. 8, pp. 31-33 (1973).
- Johnson, J. A. and Fusaro, R. M., "Persistence of Skin Color and Fluorescence after Treatment with Dihydroxyacetone," *Dermatology* 188: pp. 247 (1994).
- Kurz, T., "Formulating Effective Self-Tanners with DHA," *Cosmetics and Toiletries*, 109: No. 11, starting p. 55 (1994).

4

Levy, S. B., "Dihydroxyacetone-Containing Sunless or Self-tanning Lotions," *Journal of the American Academy of Dermatology*, 27: No. 6, pp. 989-993 (1992).

"Spray Application Processes," BINKS training brochure TD49-2R-4, August, 1995, BINKS Manufacturing Company, Franklin, Ill.

#### BRIEF DESCRIPTION OF THE DRAWINGS

A more complete understanding of the invention may be had by reference to the following Detailed Description when taken in conjunction with accompanying Drawings, wherein:

FIG. 1 is a flow chart illustrating the invention;

FIG. 2 is a diagrammatic illustration of the system for automatically coating the human body of the present invention comprising the minimum requirements thereof;

FIG. 3 is an illustration similar to FIG. 2 wherein the system of the present invention is further provided with containment apparatus;

FIG. 4 is an illustration similar to FIG. 3 wherein the system of the present invention is further provided with an air ventilation apparatus;

FIG. 5 is an illustration similar to FIG. 4 wherein the system of the present invention is further provided with collection apparatus for residual spray;

FIG. 6 is an illustration similar to FIG. 5 wherein the system of the present invention is further provided with apparatus to effect rotation of the human body being coated;

FIG. 7 is an illustration similar to FIG. 6 wherein the system of the present invention is further provided with multiple discharge nozzles; and

FIG. 8 is an illustration similar to FIG. 5 wherein the system of the present invention is adapted to the coating of a selected part of the human body.

#### DETAILED DESCRIPTION OF THE INVENTION

Referring now to the Drawings, and particularly to FIG. 1, the system for automatically coating the human body of the present invention may comprise an automated coating system for numerous types of formulations, including but not limited to the application of:

- self-tanning formulations,
- sunscreens,
- suntan lotions,
- tanning accelerators,
- sun-burn treatments,
- insect repellants,
- skin toners,
- skin bleaches,
- skin lighteners,
- anti-microbial compositions,
- moisturizers,
- exfoliants,
- nutriments or vitamins,
- massage aides,
- muscle relaxants,
- skin treatment agents,
- burn treatment agents,
- decontamination agents,
- cosmetics,
- wrinkle treatments or removers.

5,922,333

5

The first component of such a system is the chemical composition. The suitability of a composition for coating is strongly influenced by its viscosity, with the preferred viscosity being close to that of water (1 centipoise). Compositions with viscosities in the 1 to 10 centipoise range generally atomize well, and viscosities in the 10 to 100 range can be atomized, but the resulting spray is not as fine. Higher viscosities can be atomized, and will work, but the spray is not as fine. Most currently marketed compositions of the aforementioned applications can be made suitable for atomization either as is or with appropriate dilution.

By way of example, a more detailed description of functional compositions for use in practice of the invention will be based on artificial tanning compositions. Four such compositions are given in Compositions 1, 2, 3 and 4. Individuals skilled in this art can create other compositions.

Ingredient	%
<b>COMPOSITION 1</b>	
Dihydroxyacetone	3
Water	97
<b>COMPOSITION 2</b>	
Dihydroxyacetone	3.0
Denatured Ethanol	20.0
Water	77.0
<b>COMPOSITION 3</b>	
Dihydroxyacetone	12.0
Denature Ethanol	20.0
Water	68.0
<b>COMPOSITION 4</b>	
Dihydroxyacetone	10.0
Commercial Sunless-Tanning Lotion	15.0
Water	75.0

By way of example, suitable commercial preparations include Coppertone® Oil-Free Sunless Tanner (Schering-Plough, Memphis, Tenn.), Neutrogena® Glow Sunless Tanning Lotion for Face and Body (Neutrogena, Los Angeles, Calif.), and Kroger® Sunless Tanning Cream (Kroger, Cincinnati, Ohio).

Compositions 1, 2 and 3 are greatly simplified versions of the formulations now on the market or reported in the past. This simplification is possible due to the use of the present invention for applying compositions to skin. These simplified compositions have several advantages over more complex formulations, including:

- faster drying,
- less potential inhibition of DHA efficacy,
- less potential for irritation from chemical components (because there are fewer components),
- less residue on the skin,
- less expensive,
- more environmentally friendly.

Composition 4 illustrates how a commercial formulation not particularly well suited for atomization can be diluted, effectively atomized and uniformly coated on human skin. Similar dilutions of products representing the other aforementioned applications can be effectively atomized and coated on human skin.

A preferred colorant is DHA. DHA is available from Rona (Hawthorne, N.Y.). It is effective, safe, and approved by the FDA for this application. The preferred DHA concentration is 0.5% to 20%, with a more preferred range of 3.0% to

6

15.0%, and a most preferred range of 5% to 12%. Numerous other colorants can also be used. Those agents include, but are not limited to:

- crotonaldehyde
- pyruvaldehyde
- glycolaldehyde
- glutaraldehyde
- ortho-phthaldehyde
- sorbose
- fructose
- erythrose
- methylvinylketone
- food coloring

Various dyes and UV blocking agents can be covalently linked to the colorant or can be mixed into the composition with the colorant.

Bronzers can also be used in combination with or as an alternative to DHA. Bronzers which can be used include, but are not limited to, lawsone and juglone. Combinations of DHA and bronzers can also be used, and can be used to modify the resulting color (hue) and intensity of the tan. The preferred range for lawsone and juglone is 0.5% to 10.0% with the more preferred range of 1.0% to 5.0%. There is no pH adjustment required for these compositions, although the pH can be adjusted to alter the hue of the resulting tan and to alter the dihydroxyacetone stability. The optimal tanning occurs with DHA at a pH of below 6.0, preferably with the solution at pH 3.0 to 4.0. Unbuffered DHA has a pH of about 5.5. The pH on the surface of human skin is also about 5.5. Nonetheless, these formulations can be used over a wide pH range, and buffers or pH adjusters can be added.

Alcohol can be added to the composition to accelerate the rate of drying. Denatured ethanol (USP grade, commodity chemical) works well in this capacity. The preferred range for alcohol concentration is from 1.0% to 50.0%, with a more preferred range from 10.0% to 30.0%, and a most preferred concentration of 20.0%.

Other potential additives include:

- moisturizers,
- preservatives,
- antimicrobials,
- thickeners,
- solvents,
- emulsifiers,
- fragrances,
- stabilizers,
- sun-screens,
- surfactants,
- pH adjusters,
- anti-caking agents,
- ingredients to alter the color reaction.

It typically requires about 100 ml of a 5.0% DHA composition to obtain a medium to dark tan over an entire adult body (about 2 square meters of skin). A single application of about 150 ml of a 12% dihydroxyacetone composition over an entire adult human body will result in a very dark tan. The exact amount of dihydroxyacetone required depends on the skin type and intensity of tan desired. The tan can last for about 2 to 7 days, but usually lasts for 3 to 4 days. Multiple applications will darken the tan.

The second component of the invention is the atomization of the composition. The required atomization can be obtained by a host of ways, most of which involve passing

5,922,333

7

the composition through an orifice under pressure. Methods now used to atomize solutions include the use of the following systems:

- air atomization
  - siphon feed
  - gravity feed
  - pressure feed
    - internal atomization
    - external atomization
    - low pressure low volume
    - high volume low pressure
- airless atomization
  - pressurized through small orifices
- air-assisted
  - air-assisted heated
  - electrostatic
    - using charged particles
    - heated charged particles
    - high speed rotational atomizers
  - ultrasonic

These forms of atomization are the basis for most methods of producing atomized sprays, including misting and nebulization.

Using a single airless sprayer with a tip orifice of 0.6 mm, with a circular spray pattern of 12 inches at 12 inches from the tip, and with a flow rate of approximately 400 ml/min. the entire body (excluding the bottom of the feet) of an average-sized person can be coated with solution in 5 to 15 seconds. In practice, the underside of the feet usually get slightly tanned also from exposure to small quantities of residual artificial tanning composition on the floor of application area. The use of a single airless sprayer to apply a composition to human skin is illustrated in FIG. 2. In this figure and subsequent figures, 11 designates the orifice for atomization of the composition, 12 designates the atomized spray, and 13 designates the subject being sprayed. In this configuration, an operator must direct the flow of the spray. The configuration illustrated in FIG. 2 would also work for any of the other atomization methods aforementioned, and for any of the applications aforementioned. The preferred atomization method is the pressure-fee air-atomization system, with an internal or external atomization configuration.

For a person to be coated as illustrated in FIG. 2 with an artificial tanning composition (or any composition of the applications aforementioned), several precautions should be taken. First, the person should hold their breath during the application and during the time required for the spray to clear. If this process is done in an open area, the coating should take about 5 to 15 seconds and the clearing of residues should take 1 to 10 seconds. Thus, the person would need to hold their breath for 6 to 25 seconds. Alternatively, they could wear a filter over their mouth, have a filter inside of their mouth, or use a breathing tube. They can also wear nose plugs or filters. Second, the eyes should be protected even though most of these formulations are not likely to injure the eye. The simplest and most effective protection is to keep the eyes closed. Goggles or patches also work well, although they leave uncoated areas that must be subsequently coated manually. Next, precautions need to be taken if one wants to avoid the exposure of scalp hair. Scalp hair can be protected with a shower cap or any other similar protective covering impervious to the coating compositions. Also, hair can be coated with a water insoluble material such as petroleum jelly. Similar protection can be used to protect hair on any other parts of the body. Next, if atomization is

8

from a single source, it is recommended that the person being coated turn while being coated, or that the coating apparatus be moved around the person being coated, or there be a combination of these movements. Finally, care must be taken that the nozzle remain at least several inches from the person being coated to prevent any possible injection of composition into the person. Generally, spray injection occurs at pressures greater than 500 psi with the person actually contacting the atomization orifice. The pressures here are less than 80 psi, and more typically 10 to 40 psi, and the person being coated should be a foot or more from the orifice.

The issue of what to wear during coating is usually of great concern to the person being coated. In the case of coating with artificial tanning solution, the selection of what to wear is a matter of preference for the person being coated. The subject can be coated nude, with underwear, with a bikini or a bathing suit, or with some form of pasties covering their private parts.

The third component of the invention is containment of the spray. Containment is illustrated in FIG. 3. In this figure and subsequent figures, 14 and 15 designate side panels and 16 and 17 designate the top and bottom panels, respectively. This type of containment is similar to the containment of spray paint using paint booths in automobile refinishing. Alternatively, spray containment can be obtained using electrostatic forces, where the atomized spray is charged and the residual charged spray is removed by activating charged collection plates. Of course, precautions must be taken so that the person being sprayed and the operator are isolated from the charged plates.

Containment of the spray is very important for several reasons. These reasons include but are not limited to:

- reducing waste,
- avoiding spray getting onto and staining items in the immediate surroundings,
- facilitating capture and recovery processes,
- better control of air flow,
- better control of temperature and humidity.

This type containment facilitates the use of this invention in enclosed areas such as stores or medical facilities.

Control of air and spray flow is very important to the quality of the skin coating. It is highly preferable to have an exhaust fan drawing the spray towards the person being coated, and the residual composition out of the booth. In FIG. 4 is shown the addition of an exhaust fan 18. The fan offers several significant advantages to the invention. These advantages include but are not limited to:

- better control of air flow
- shorter exposure to residue spray, requiring less time to hold breath or breathe through filter or air line
- faster drying of the coated composition on skin
- better quality coating

The fan 18 should have a flow of 10 to 5000 cubic feet per minute per square foot of opening, preferably 50 to 1000 cubic feet per minute per square foot, and most preferably 100 to 400 cubic feet per minute per square foot. At flow rates of below 100 cubic feet per minute per square foot, the air movement is sufficient to guide the atomized spray through the containment area. At flow rates of 100 to 400 cubic feet per minute per square foot, the atomized spray is being actively drawn through the containment area and the application and drying process is enhanced. At rates above 400 cubic feet per minute per square foot, the atomized spray is being accelerated and the exhaust flow plays a much more prominent role in the application process. The flow

5,922,333

9

rate of the air through the containment area is therefore a major parameter which can be varied to modify the characteristics of the coating of the artificial tanning composition to the skin. The drying time for the composition deposited on skin is also effected by flow rate, with drying time decreasing as flow rates increase. At rates above 100 cubic feet per minute per square foot, the drying time (to the point of no transfer to other surfaces upon contact) is less than 5 minutes.

At any flow rate above 10 cubic feet per minute per square foot, the residual atomized spray is completely removed from the containment area within one second. This rapid removal is important to minimize the time the person being tanned is exposed to spray and has the potential to inhale this spray. In the absence of this air flow, the residual spray lingers in the area for several minutes, and traces can be detected hours later. This vigorous flow also protects any individuals or operators near the atomizing orifices from back spray.

The final element of this invention is recovery, or filtering, of residual composition. This feature greatly enhances the utility of the invention because it allows the system to be self-contained in an indoor environment and promotes a more environmentally friendly process. Without a recovery system, there is a potential for the exhausted residue to stain anything it contacts. Also, there could be an accumulation of residue with time. One configuration of the recovery system is shown in FIG. 5. In this figure and subsequent figures, the recovery system or filter is denoted as 19. Recovery of both particulates and solvents is possible. Potential filters include a high-efficiency filter such as Binks' (Franklin Park, Ill.) Paint Pockets or Columbus Industries' (Ashville, Ohio) High-Capacity Supra Mini-Mesh, a form of a carbon filter, a water-wash filter, or an exchange-type resin. The efficiency of particulate and solvent removal should be greater than 99%. As an alternative to high-efficiency filtering, the spray residuals could be vented to the outside environment.

Additional features adding to the utility of the invention are shown in FIG. 6 and FIG. 7. In FIG. 6 there is shown the addition of a motorized turntable 20. This turntable 20 will rotate the person being coated, eliminating rotation by the individual as a possible source of error or problems. It also is a major convenience for the person being coated. The preferred rate of rotation is in the range of 1 to 60 rpm, with a more preferred range of 5 to 20 rpm, with a most preferred rate of rotation of 12 rpm.

In FIG. 7 there is shown the use of multiple atomizing orifices. The use of multiple orifices facilitates the automation of this process, and reduces operator effort and potential error. It also reduces the time required to fully coat an individual. The typical round spray pattern is about 12 inches wide at 8 to 12 inches from the orifices, so a preferred spacing of multiple orifices will be 8 to 12 inches apart, but could be positioned from 1 to 48 inches apart. Fan patterns from wide-angle nozzles at 18 inches are typically 24 inches long and 9 inches wide. Using the preferred configuration, an individual can be coated in 5 seconds or less. In FIG. 7, the orifices are aligned in a vertical pattern. The coverage of more area at one time could also be obtained by rapidly moving one or more orifices along a track or by rapidly altering the angle of the orifice. Other patterns are possible, including combinations of vertical and horizontally aligned orifices. Orifices could also be aligned radially, with the subject being sprayed with orifices aligned from 0 to 360°. Another alignment is a horizontal ring containing orifices that surround the body. By vertically raising and lowering the horizontal ring, the entire body or selected parts of the body could be coated.

10

In an open environment, such as a beach or a park, a modified version of configuration illustrated in FIG. 7 could be used to rapidly coat an individual. It would even be possible to have a walk-through coating system. An atomized spray could be produced from multiple nozzles arranged in a single line (as shown in FIG. 7), in two single lines facing one another and about 36 to about 48 inches apart, or multiple lines of nozzles. The preferred configuration is multiple lines, with 4 lines being adequate. The atomized spray results in an area of intense atomized solution, which would coat an individual standing in that area. The residual spray would then be dissipated into the surrounding environment. A fan could be used to accelerate the removal of the residuals from the coating area.

FIG. 8 illustrates how the system of the present invention can be used to tan a selected part of the body. In this case, just the face is being tanned. In this figure the bottom panel of the apparatus 22 contains an opening through which one can insert his or her head. The top panel 23 is arched. The high-efficiency filter is 19. The fan and back panel is 15. Alternately, the setup as shown in FIGS. 2-7 could be used to tan only a select part of the body by protecting the area not desired to be tanned with appropriate barrier apparel or by screens between the atomized spray and the regions of the skin not to be coated. The barrier apparel could be any material impervious to the atomized coating composition. For example, materials appropriate for use with the aforementioned coating compositions include vinyl, polyurethane, and latex rubber. The screens can be sheets composed of any material impervious to the atomized artificial tanning compositions, including most metals or plastics. A preferred screening material is foam with an impervious aluminum foil backing. The foam is aligned with the backing away from the atomizing orifice. The foam is preferred because it absorbs much of the atomized spray, reducing back deflection.

Although preferred embodiments of the invention are illustrated in the Drawings and described in the Detailed Description, it will be understood that the invention is not limited to the embodiments disclosed, but is capable of numerous modifications and rearrangements of parts and elements without departing from the spirit of the invention.

What is claimed is:

1. A method of coating human skin including the steps of:
  - a. providing a predetermined human skin coating composition;
  - b. atomizing the human skin tanning composition at a predetermined rate;
  - c. directing the atomized composition onto at least predetermined portions of the body of the person to be coated;
  - d. containing the atomized spray; and
  - e. capturing the portion of the atomized spray not deposited on the body of the person being coated.
2. The method for artificially coating human skin according to claim 1 wherein the predetermined human skin coating composition comprises dihydroxyacetone in a concentration of between about 0.5% and about 20%, with the balance of the composition comprising water.
3. The method for artificially coating human skin according to claim 1 wherein the predetermined human skin coating composition comprises a naphthoquinone in a concentration of between about 0.5% and about 10%, with the balance of the composition comprising water.
4. The method of artificially coating human skin according to claim 1 wherein the predetermined human skin

5,922,333

11

coating composition comprises dihydroxyacetone in a concentration of between about 0.5% and about 20%, a naphthoquinone in a concentration of between about 0.5% and about 10%, with the balance of the composition comprising water.

5. The method of artificially coating human skin according to claim 2 wherein the predetermined human skin coating composition further includes an alcohol in a concentration of between about 1% and about 50%.

6. The method of artificially coating human skin according to claim 3 wherein the predetermined human skin coating composition further includes an alcohol in a concentration of between about 1% and about 50%.

7. The method of artificially coating human skin according to claim 4 wherein the predetermined human skin coating composition further includes an alcohol in a concentration of between about 1% and about 50%.

8. The method of artificially coating human skin according to claim 2 wherein the predetermined human skin coating composition further includes a predetermined artificial tanning cream or lotion in a concentration of between about 5% and about 20%.

9. The method for coating human skin according to claim 1 wherein the coating composition is a predetermined sunscreen composition.

10. The method for coating human skin according to claim 1 wherein the coating composition is a predetermined suntanning composition.

11. The method for coating human skin according to claim 1 wherein the coating composition is a predetermined tanning accelerator composition.

12. The method for coating human skin according to claim 1 wherein the coating composition is a predetermined sunburn treatment composition.

13. The method for coating human skin according to claim 1 wherein the coating composition is a predetermined insect repellent composition.

14. The method for coating human skin according to claim 1 wherein the coating composition is a predetermined skin toner composition.

15. The method for coating human skin according to claim 1 wherein the coating composition is a predetermined skin bleach composition.

16. The method for coating human skin according to claim 1 wherein the coating composition is a predetermined skin lightening composition.

17. The method for coating human skin according to claim 1 wherein the coating composition is a predetermined anti-microbial composition.

18. The method for coating human skin according to claim 1 wherein the coating composition is a predetermined moisturizer composition.

19. The method for coating human skin according to claim 1 wherein the coating composition is a predetermined exfoliant composition.

20. The method for coating human skin according to claim 1 wherein the coating composition is a predetermined nutrient and vitamin composition.

21. The method for coating human skin according to claim 1 wherein the coating composition is a predetermined massaging aide composition.

22. The method for coating human skin according to claim 1 wherein the coating composition is a predetermined muscle relaxant composition.

23. The method for coating human skin according to claim 1 wherein the coating composition is a predetermined medicated skin treatment composition.

12

24. The method for coating human skin according to claim 1 wherein the coating composition is a predetermined burn treatment composition.

25. The method for coating human skin according to claim 1 wherein the coating composition is a predetermined decontamination composition.

26. The method for coating human skin according to claim 1 wherein the coating composition is a predetermined cosmetic composition.

27. The method for coating human skin according to claim 1 wherein the coating composition is a predetermined wrinkle treatment composition.

28. The method of coating human skin according to claim 1 wherein the step of atomizing the coating composition comprises forcing the composition through a small diameter orifice and producing an atomized spray.

29. The method of coating human skin according to claim 1 wherein the step of directing the atomized spray of coating composition onto the body of the person to be coated includes the step of directing a flow of air containing the atomized composition pass the body of the person being coated at a rate of between about 10 cubic feet a minute and about 5000 cubic feet a minute per square foot.

30. The method of coating human skin according to claim 1 further includes the step of rotating the body of the person to be coated around a vertical axis during the application of the atomized coating composition.

31. The method of coating human skin according to claim 1 wherein the step of atomizing the coating composition is further characterized by forcing the predetermined coating composition through a plurality of small diameter orifices.

32. A method of coating human skin according to claim 1 wherein the steps for containing the atomized spray and for capturing the portion of atomized spray not deposited on the body of the person being coated are carried out by dissipating the uncoated atomized spray into the surrounding environment.

33. The method of coating human skin according to claim 1 wherein the step of capturing the portion of the atomized spray not deposited on the body of the person being coated is accomplished by the use of electrostatic plates which draw the charged residual spray from the area where the person is being coated to one or more adjacent areas containing the charged electrostatic plates.

34. A method of coating human skin including the steps of;

- a. providing a predetermined human skin coating composition;
- b. atomizing the human skin tanning composition at a predetermined rate;
- c. directing the atomized human skin tanning composition onto at least predetermined portions of the body of a person to be tanned;
- d. containing the atomized spray; and
- e. capturing the portion of the atomized spray which is not deposited on the body of the person being tanned.

35. The method for artificially coating human skin according to claim 34 wherein the predetermined human skin coating composition comprises dihydroxyacetone in a concentration of between about 0.5% and about 20%, with the balance of the composition comprising water.

36. The method of artificially coating human skin according to claim 34 wherein the predetermined human skin coating composition comprises a naphthoquinone in a concentration of between about 0.5% and about 10%, with the balance of the composition comprising water.



5,922,333

13

37. The method of artificially coating human skin according to claim 34 wherein the predetermined human skin coating composition comprises dihydroxyacetone in a concentration of between about 0.5% and about 20%, a naphthoquinone in a concentration of between about 0.5% and about 10%, with the balance of the composition comprising water.

38. The method of artificially coating human skin according to claim 35 wherein the predetermined human skin coating composition further includes an alcohol in a concentration of between about 1% and about 50%.

14

39. The method of artificially coating human skin according to claim 36 wherein the predetermined human skin coating composition further includes an alcohol in a concentration of between about 1% and about 50%.

40. The method of artificially coating human skin according to claim 37 wherein the predetermined human skin coating composition further includes an alcohol in a concentration of between about 1% and about 50%.

\* \* \* \* \*



US006298862B1

(12) **United States Patent**  
Laughlin

(10) Patent No.: **US 6,298,862 B1**  
(45) Date of Patent: **\*Oct. 9, 2001**

(54) **METHOD OF AND APPARATUS FOR AUTOMATICALLY COATING THE HUMAN BODY: FOGGING TECHNOLOGY**

(52) U.S. Cl. .... 132/200; 132/333; 424/401  
(58) Field of Search ..... 132/333, 200; 424/401, 59, 78.02, 78.03, 78.06

(75) Inventor: **Thomas J. Laughlin, Grapevine, TX (US)**

(56) **References Cited**

(73) Assignee: **Laughlin Products, Inc., Grapevine, TX (US)**

**U.S. PATENT DOCUMENTS**

(\* ) Notice: Subject to any disclaimer, the term of this patent is extended or adjusted under 35 U.S.C. 154(b) by 0 days.

5,273,214 \* 12/1993 Huffstutler ..... 239/279  
5,664,593 \* 9/1997 McClain ..... 132/333  
5,922,333 \* 7/1999 Laughlin ..... 424/401

\* cited by examiner

This patent is subject to a terminal disclaimer.

*Primary Examiner*—John J. Wilson  
*Assistant Examiner*—Robyn Kieu Doan  
(74) *Attorney, Agent, or Firm*—Michael A. O'Neil

(21) Appl. No.: **09/663,023**

(57) **ABSTRACT**

(22) Filed: **Sep. 15, 2000**

In a system for coating human skin, a chemical composition, such as a cosmetic or medical formulation, is uniformly coated over the entire body or selected parts of the body of the person being coated. The system includes atomization of the coating composition, containment of the atomized spray, and residual recovery which together yield a novel method for applying chemical compositions.

**Related U.S. Application Data**

(63) Continuation-in-part of application No. 09/294,689, filed on Apr. 19, 1999, which is a continuation-in-part of application No. 08/946,764, filed on Oct. 8, 1997, now Pat. No. 5,922,333.

(51) Int. Cl.<sup>7</sup> ..... A45D 24/00; A45D 44/00; A61K 6/00

**20 Claims, 10 Drawing Sheets**

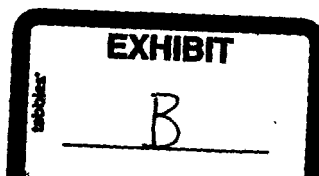
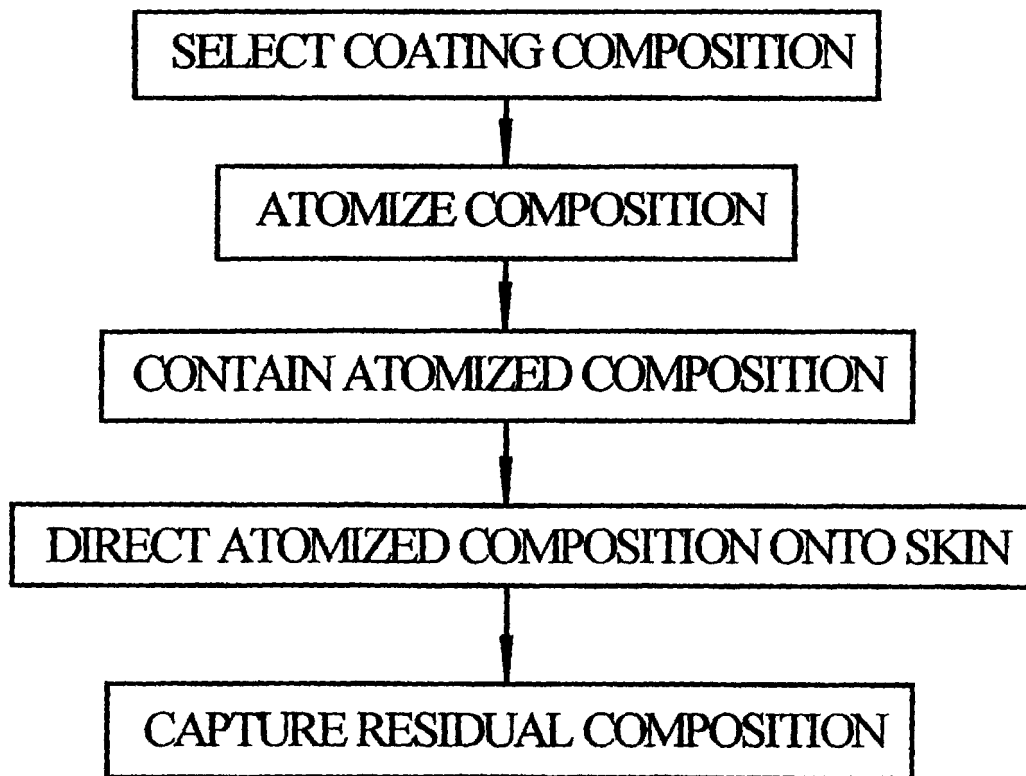

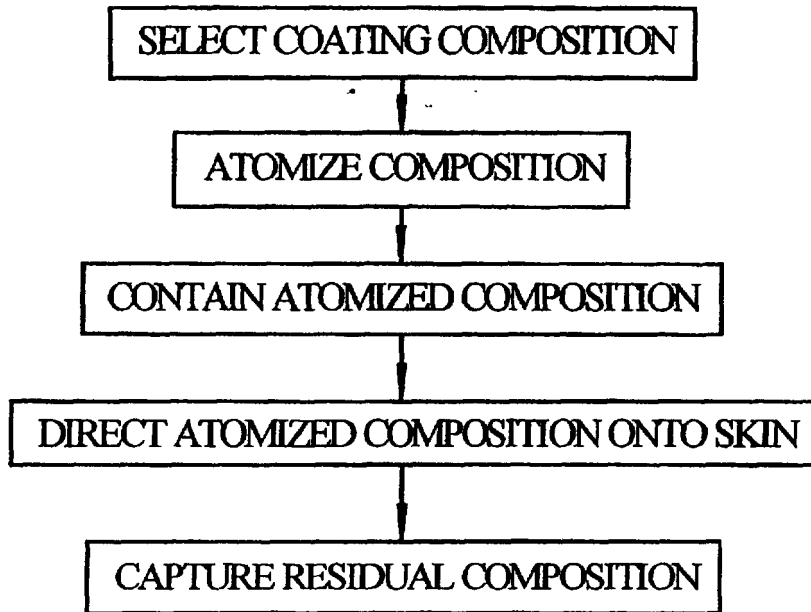

*Fig. 1*

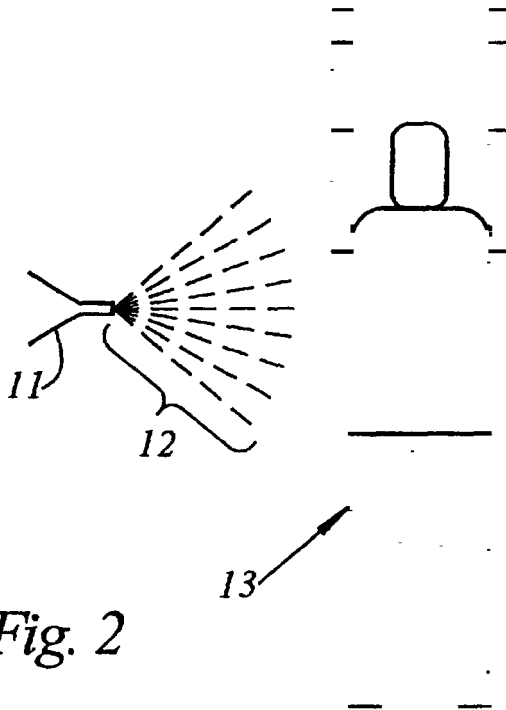

*Fig. 2*

U.S. Patent

Oct. 9, 2001

Sheet 2 of 10

US 6,298,862 B1

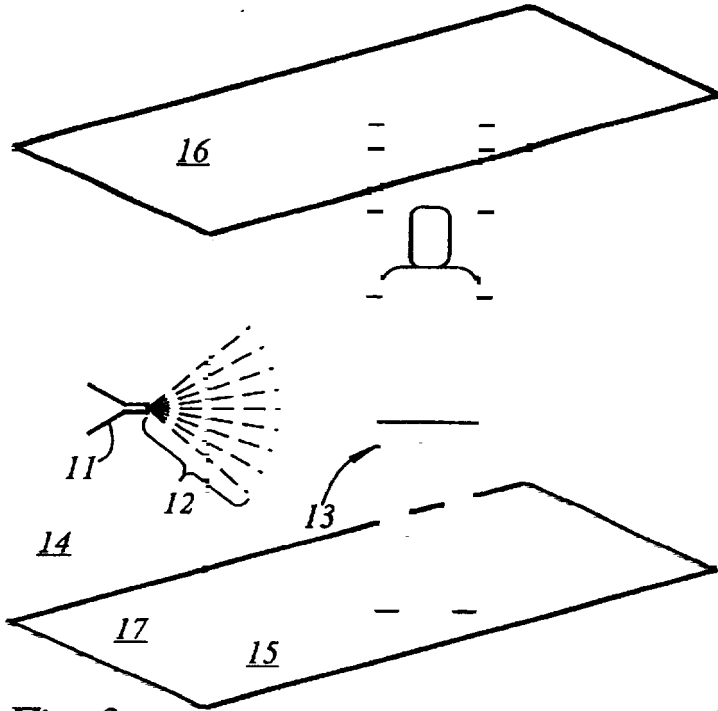

Fig. 3

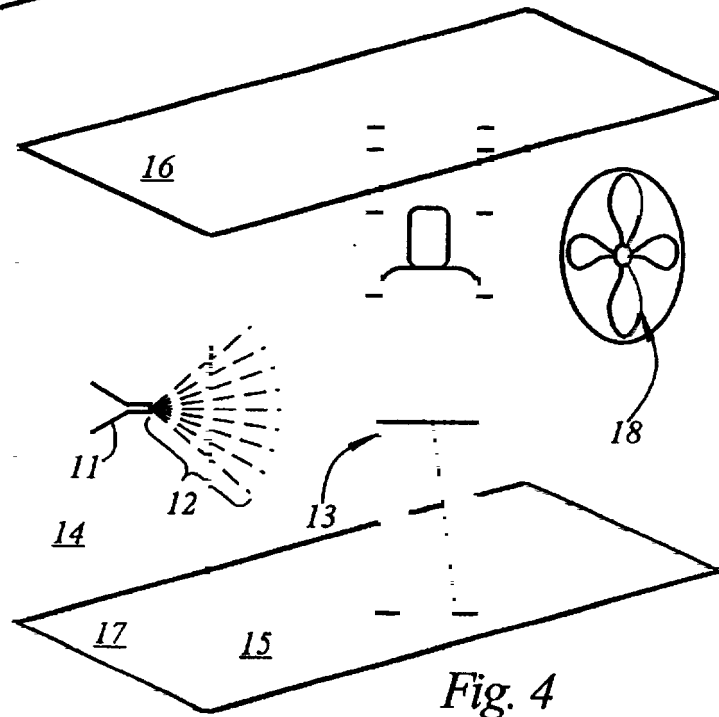

Fig. 4

**U.S. Patent**

**Oct. 9, 2001**

**Sheet 3 of 10**

**US 6,298,862 B1**

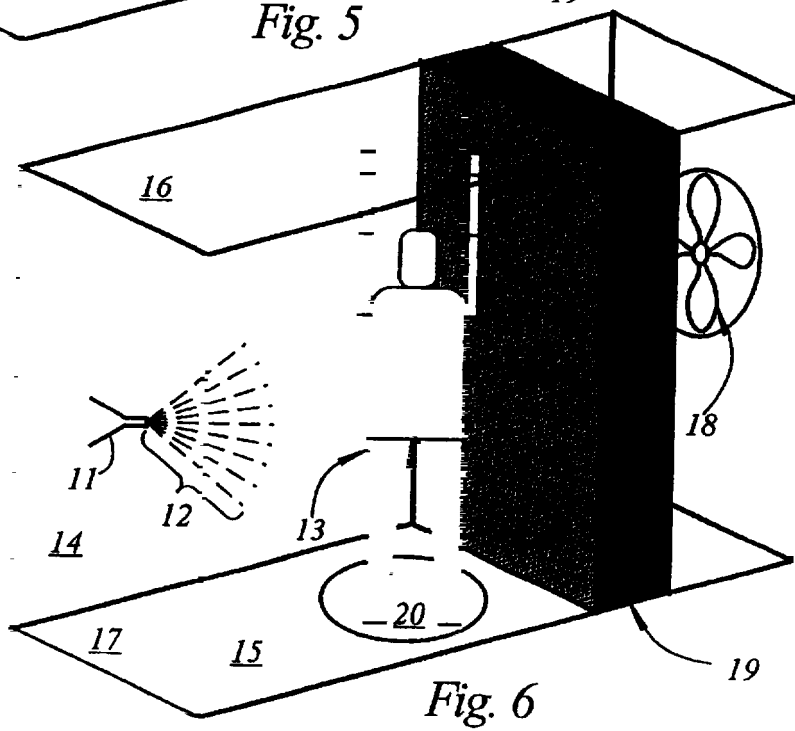
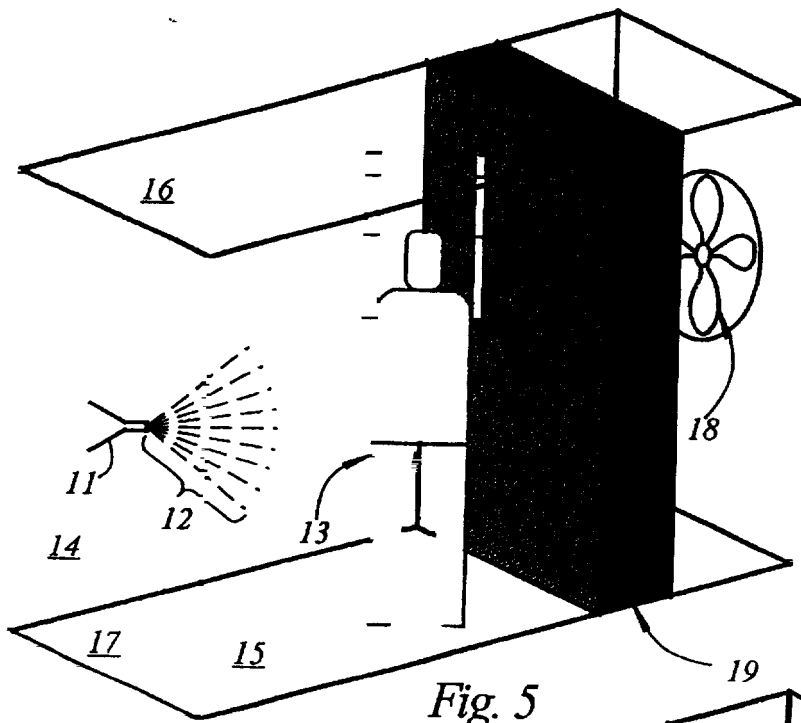

U.S. Patent

Oct. 9, 2001

Sheet 4 of 10

US 6,298,862 B1

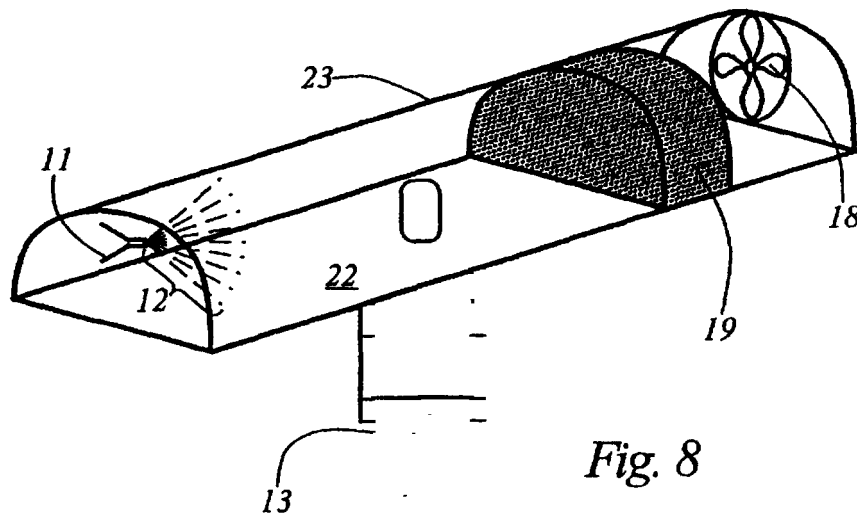
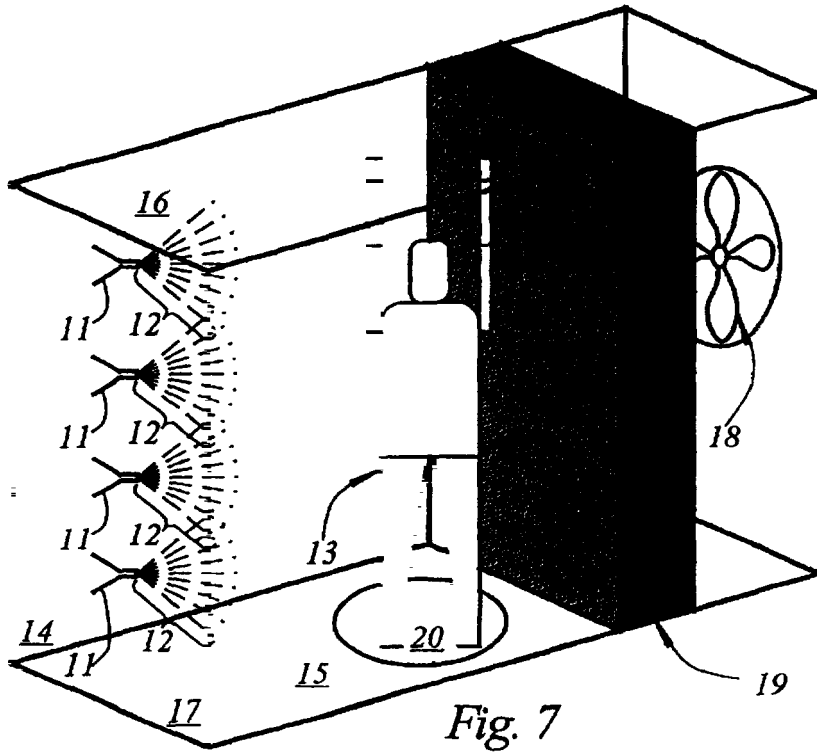

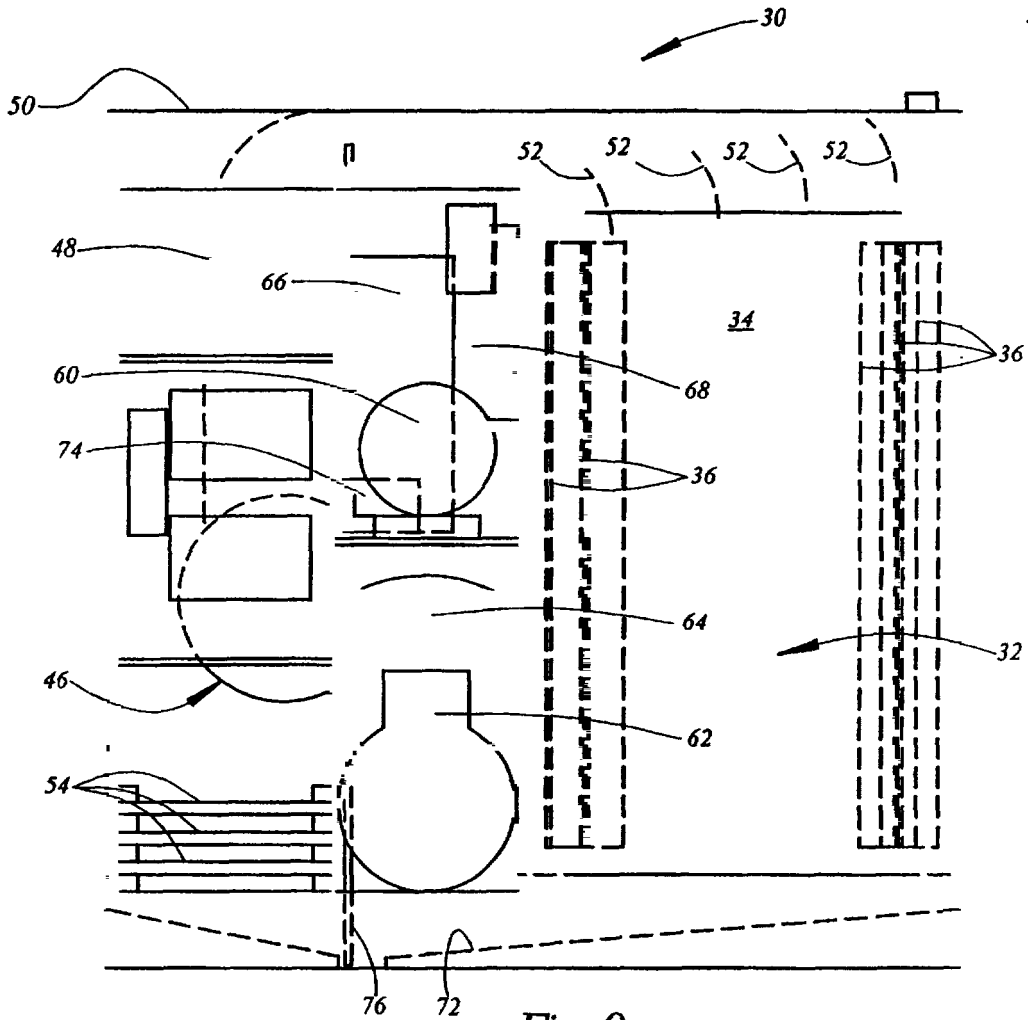

Fig. 9

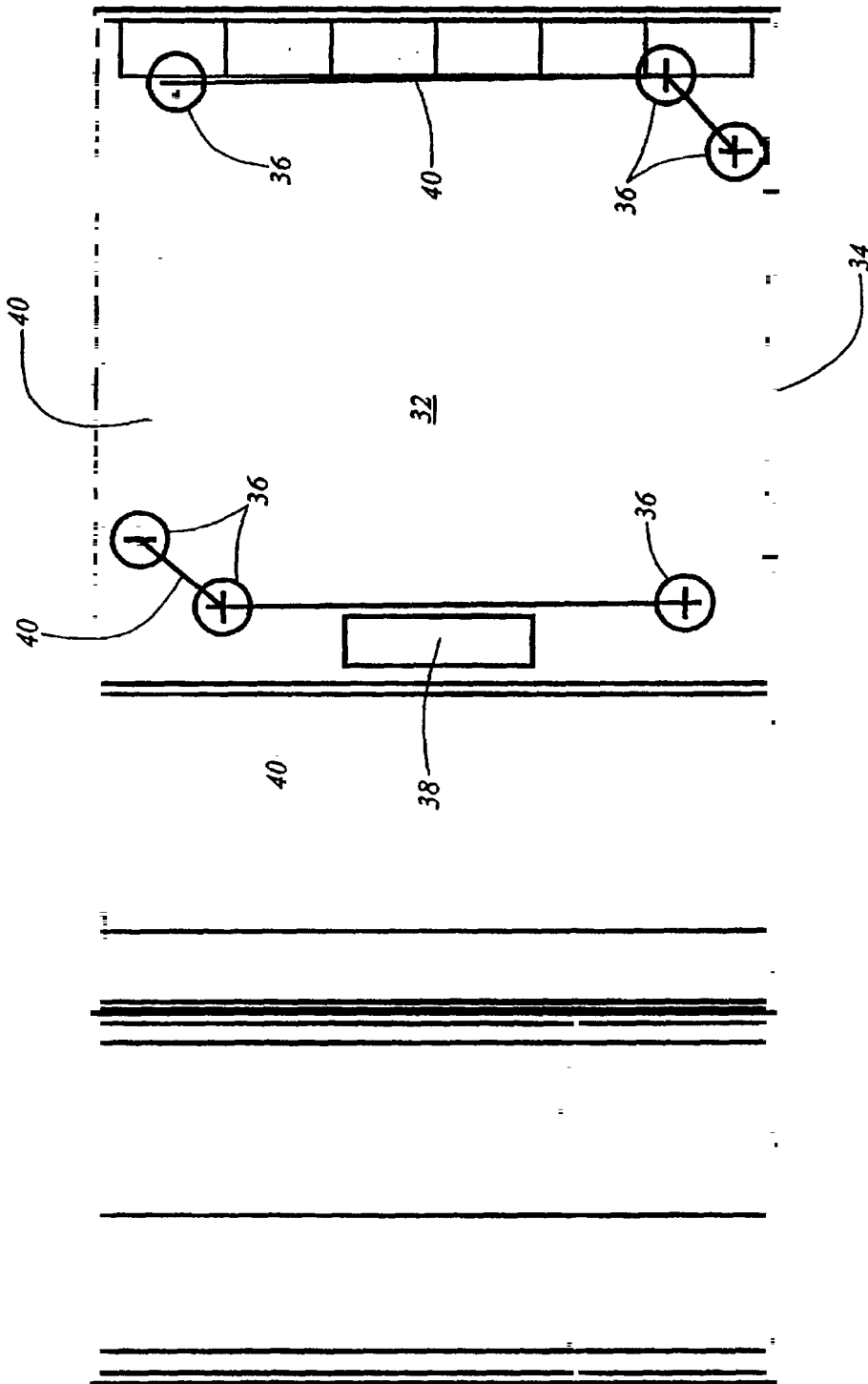

Fig. 10



U.S. Patent

Oct. 9, 2001

Sheet 7 of 10

US 6,298,862 B1

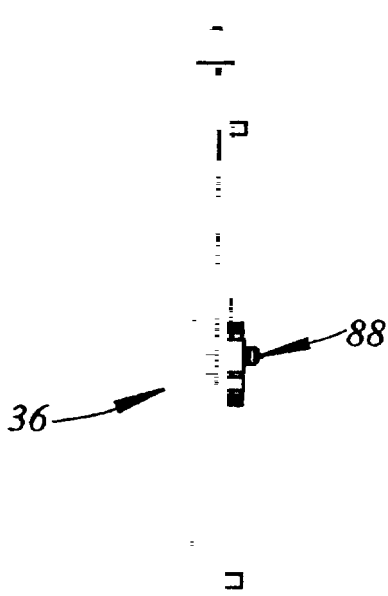

Fig. 11

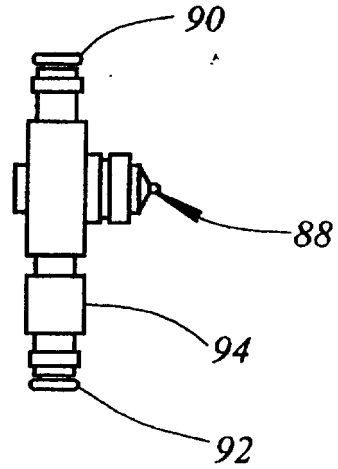
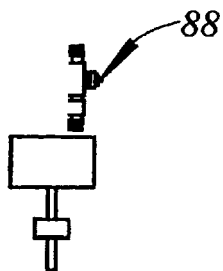

Fig. 12

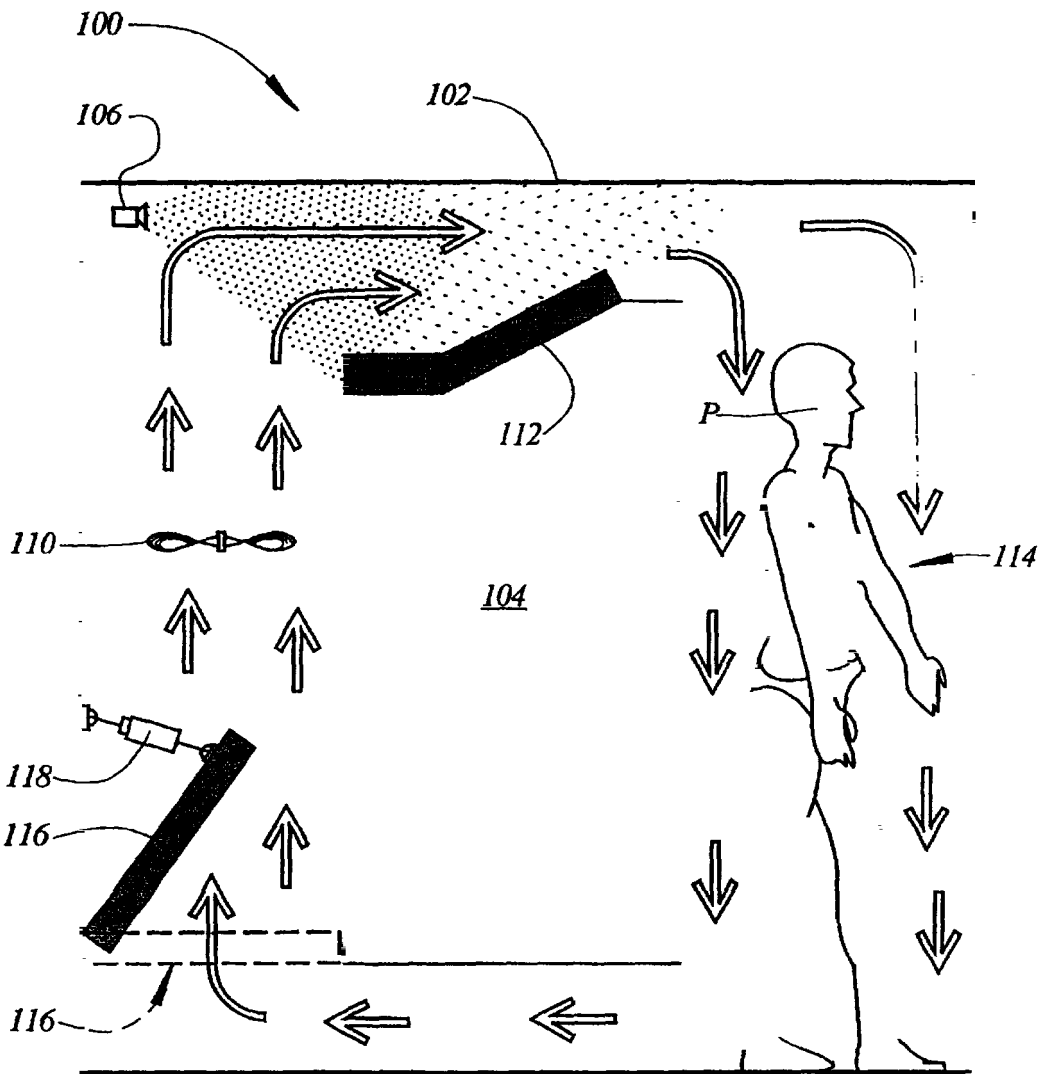

Fig. 13

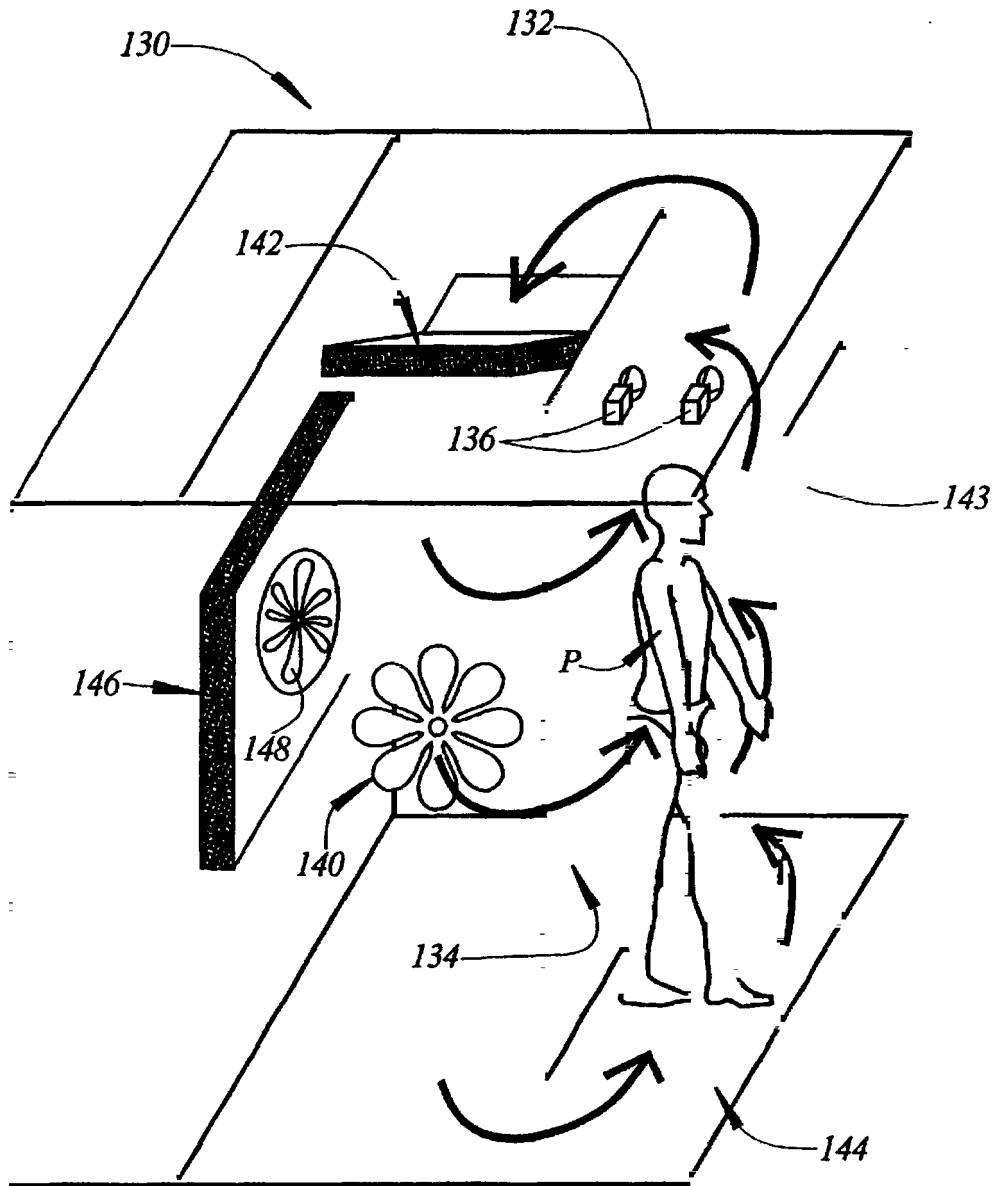

Fig. 14

U.S. Patent

Oct. 9, 2001

Sheet 10 of 10

US 6,298,862 B1

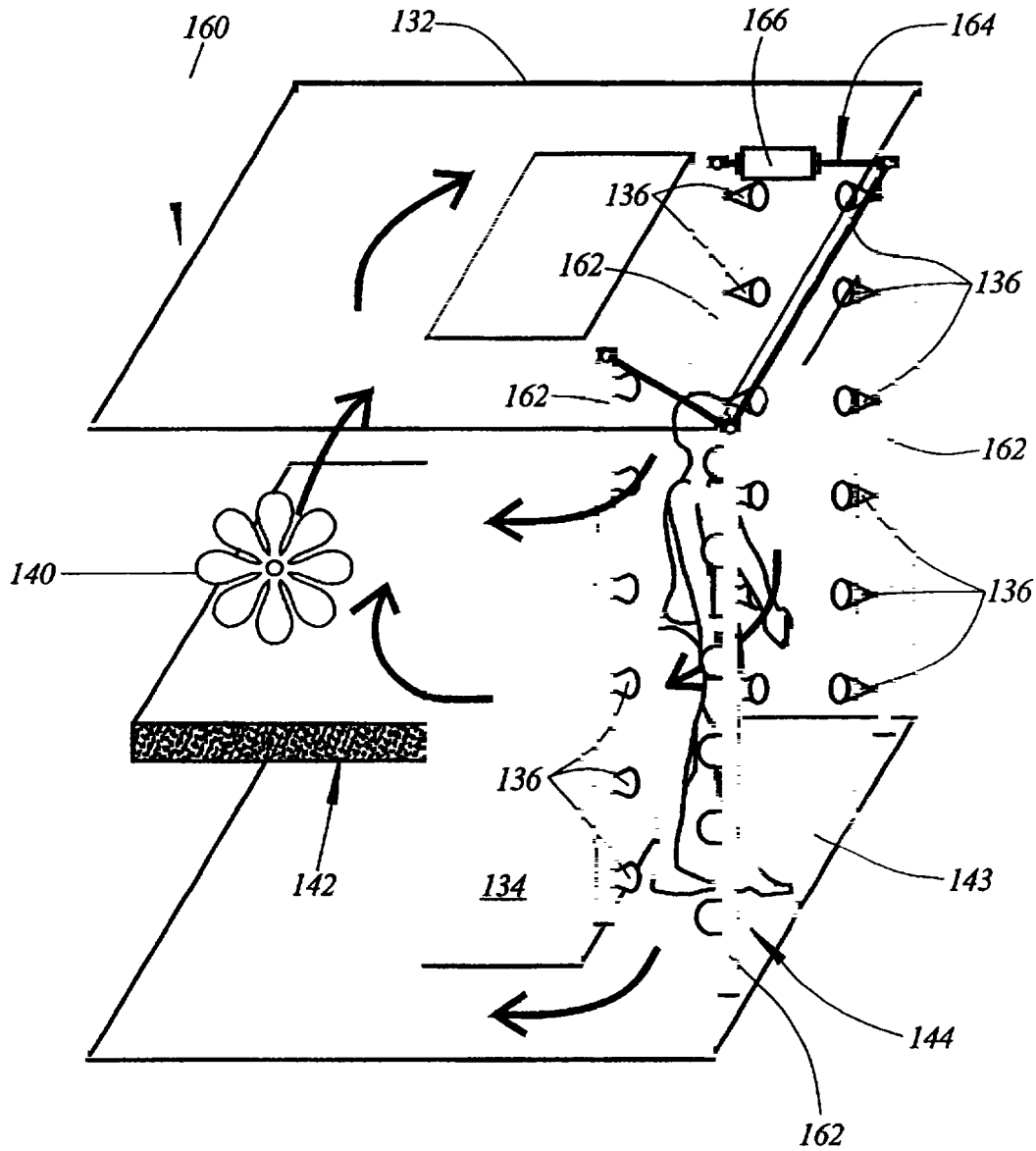

Fig. 15

US 6,298,862 B1

1

**METHOD OF AND APPARATUS FOR  
AUTOMATICALLY COATING THE HUMAN  
BODY: FOGGING TECHNOLOGY**

**CROSS-REFERENCE TO RELATED  
APPLICATION**

This application is a continuation-in-part of application Ser. No. 09/294,689, filed Apr. 19, 1999, currently pending, which is a continuation-in-part of Application Ser. No. 08/946,764, filed Oct. 8, 1997, now U.S. Pat. No. 5,922,333.

**CLAIM OF PRIORITY**

Applicant claims priority based on provisional patent application Ser. No. 60/154,684, filed Sep. 21, 1999.

**TECHNICAL FIELD**

The present invention relates generally to systems for automatically coating the human body or selected parts thereof with predetermined fluids. More particularly, the invention relates to an automated system that coats the body using a fog of composition contained in a defined area.

**BACKGROUND OF THE INVENTION**

The application of various fluids to all or selected parts of the human body has been known literally for centuries. However, despite the long-standing and widespread practice of coating the human body with various fluids, there has never been a successful way of automatically coating the human body. Therefore, prior to the present invention, it has been necessary to apply fluids to the body manually.

Manual application of fluids to the human body results in numerous disadvantages. First, it is almost impossible to uniformly coat the human body with fluids using manual application techniques. This is true even in the case of fluids that are provided in aerosol or spray form because such fluids must be rubbed in after application. Second, the application of fluids to certain parts of the human body, for example, the back, require the availability of an assistant in order that proper manual application can be attempted.

The foregoing difficulties are particularly apparent in the case of artificial tanning processes. Artificial tanning has been known for more than 40 years, with artificial tanning products appearing on the U.S. market as early as 1959. The two key types of tanning processes are by colorants and bronzers.

Tanning by colorants is based on the color reaction which occurs between components of the skin and the colorant. The most commonly used chemical for artificial tanning is dihydroxyacetone (DHA). It is widely used in commercial artificial tanning products, and is recognized as safe and effective by the U.S. Food and Drug Administration (FDA). DHA reacts solely with the stratum comeum. It interacts with amines, peptides and free amino acids to generate a Maillard reaction. The resulting products are cyclic and linear polymers that have a yellow or brown color.

Two common bronzers are juglone and lawsone. Both are naphthoquinones. When applied to skin, lawsone produces an orange hue and juglone produces a greenish-brown tan. They are sometimes used in combination with DHA to modify the color or hue of the tan or to intensify the color.

Numerous forms of artificial tanning products are now on the market. They include:

- lotions,
- creams,

2

- gels,
- oils,
- sprays.

These products are mixtures of a chemically-active skin colorant or a bronzer with combinations of the following:

- moisturizers,
- preservatives,
- anti-microbials,
- thickeners,
- solvents,
- emulsifiers,
- fragrances,
- surfactants,
- stabilizers,
- sunscreens,
- pH adjusters,
- anti-caking agents,
- ingredients to alter the color reaction.

Users of these products often experience significant problems associated with the current methods for applying artificial tanning formations to skin. These problems include the following.

If not properly dried, the formulation will streak or form blotches with time. The net result is a very nonuniform tan, with light or dark streaks or blotches.

Certain parts of the body will stain more intensely when the formulation is spread manually. This differential staining is due to enhanced absorption of certain skin tissue and the tendency of certain tissue to retain more formulation. The result is that as the formulation is being spread manually, certain tissue absorb or trap more formulation (e.g., the wrinkles in the elbows and knees and the dense tissue in the palms).

Most products designed for manual application require components such as thickeners and polymers, which often inhibit the efficacy of DHA.

Current formulations typically take about 20 minutes to dry to the touch, and about 1 hour before not transferring from skin to textiles.

Application of artificial tanning products is additionally complicated by the tendency of these formulations to stain materials containing amine molecules, including certain fabrics, certain types of carpet, and certain wall coverings and paint.

In spite of all of these problems, artificial tanning is becoming increasingly popular. It is apparent that a need exists for a superior application system which solves the foregoing problems.

There is also a need for a superior applications system for many other applications, including but not limited to:

- self-tanning formulations,
- sunscreens,
- suntan lotions,
- tanning accelerators,
- sunburn treatments,
- insect repellants,
- skin toners,
- skin bleaches,
- skin lighteners,
- anti-microbial compositions,
- moisturizers,

US 6,298,862 B1

3

exfoliants,  
 nutriments or vitamins,  
 massage aides,  
 muscle relaxants,  
 skin treatment agents,  
 burn treatment agents,  
 decontamination agents,  
 cosmetics,  
 wrinkle treatments or removers.

There are specific and significant problems with the manual coating of each of these products. The artificial tanning application provides a good illustration of the types of problems normally encountered when manually coating with these products. Artificial tanning is also one of the most demanding applications in that uniformity of the coating is critical to assure uniform tanning.

SUMMARY OF THE INVENTION

The present invention comprises a system for automatically coating the human body, including a method of and apparatus for uniformly and rapidly coating all or selected parts of the human body. The system includes apparatus which atomizes (also referred to as aerosolization, nebulization, mist generation, fog generation or spray generation) a chemical composition and deposits it uniformly over all or selected parts of the human body. It is not necessary for the individual receiving the treatment nor anyone else to manually apply any of the formulation. Also, a containment system is provided which restrains and collects residue from the application process. The system can optionally recycle the materials used.

There are several major advantages resulting from the use of the invention:

- Uniform application minimizes or eliminates streaking, No assistant is required for applying the composition,
- The entire skin surface receives the same exposure to the composition, so the uniformity of the coating is greatly enhanced over manual application,
- The optimal formulation for atomization is very simple, and does not require the addition of components which may inhibit the efficacy of the applied material,
- The application time can be as quick as a few seconds, and complete drying can occur in just a few minutes,
- The containment system drastically reduces the unwanted environmental impact,
- Multiple applications can be used to better control the amount of material applied per unit area, and additional substances can be applied in separate applications.

The invention may be practiced utilizing a unitary construction including both a coating chamber and apparatus for coating a person situated within the coating chamber. A door provides ingress to and egress from the coating chamber which is provided with strategically located spray discharging nozzles situated inside the chamber or in an adjacent area. A blower circulates air through the coating chamber to effect drying following the coating procedure and to aid in containment of excess spray. An air compressor supplies liquid for coating and compressed air for spraying the coating liquid to the nozzles situated within the coating chamber.

4

REFERENCES

U.S. Pat. Nos.

3,932,151	1/1976	Lau	55/229
4,231,289	11/1980	Domicent	98/115
5,268,166	12/1993	Barnett	424/047

Foreign patent documents

WO 94/12146 6/1994	PCT Int'l Appl.
--------------------	-----------------

Other publications

- Akins, F. J. and Marlowe, E., "Non-Carcinogenicity of Dihydroxyacetone by Skin Painting," *Journal of Environmental Pathology and Toxicology*, 5: No. 5, pp. 349-351 (1984).
- Federal Register, "Color Additive Dihydroxyacetone"38: No. 148, p. 21615, Aug. 2, 1973.
- Futterer, E., "Theory and Practice of Artificial Tanning: Literature and Patent Survey," *Cosmetics and Perfumes*, 88: No. 8, pp. 31-33 (1973).
- Johnson, J. A. and Fusaro, R. M., "Persistence of Skin Color and Fluorescence after Treatment with Dihydroxyacetone," *Dermatology* 188: pp. 247 (1994).
- Kurz, T., "Formulating Effective Self-Tanners with DHA," *Cosmetics and Toiletries*, 109: No. 11, starting p. 55 (1994).
- Levy, S. B., "Dihydroxyacetone-Containing Sunless or Self-tanning Lotions," *Journal of the American Academy of Dermatology*, 27: No. 6, pp. 989-993 (1992).
- "Spray Application Processes," BINKS training brochure TD49-2R-4, August, 1995, BINKS Manufacturing Company, Franklin, Ill.

BRIEF DESCRIPTION OF THE DRAWINGS

A more complete understanding of the invention may be had by reference to the following Detailed Description when taken in conjunction with accompanied Drawings, wherein:

- FIG. 1 is a flow chart illustrating the invention;
- FIG. 2 is a nagrammatic illustration of the system for automatically coating the human body of the present invention comprising the minimum requirements thereof;
- FIG. 3 is an illustration similar to FIG. 2 wherein the system of the present invention is further provided with containment apparatus;
- FIG. 4 is an illustration similar to FIG. 3 wherein the system of the present invention is further provided with an air ventilation apparatus;
- FIG. 5 is an illustration similar to FIG. 4 wherein the system of the present invention is further provided with collection apparatus for residual spray;
- FIG. 6 is an illustration similar to FIG. 5 wherein the system of the present invention is further provided with apparatus to effect rotation of the human body being coated;
- FIG. 7 is an illustration similar to FIG. 6 wherein the system of the present invention is further provided with multiple discharge nozzles;
- FIG. 8 is an illustration similar to FIG. 5 wherein the system of the present invention is adapted to the coating of a selected part of the human body;

US 6,298,862 B1

5

FIG. 9 is a front view of an apparatus useful in the practice of the invention;

FIG. 10 is a top view of the apparatus of FIG. 9;

FIG. 11 is an illustration of one of the spray columns of the apparatus of FIG. 9;

FIG. 12 is an enlarged view illustrating the nozzle assemblies utilized in the spray columns of the apparatus of FIG. 9;

FIG. 13 is a diagrammatic illustration of an alternative apparatus useful in the practice of the invention;

FIG. 14 is a diagrammatic illustration of a first variation of the apparatus of FIG. 13; and

FIG. 15 is a diagrammatic illustration of a second variation of the apparatus of FIG. 13.

DETAILED DESCRIPTION OF THE INVENTION

Referring now to the Drawings, and particularly to FIG. 1, the system for automatically coating the human body of the present invention may comprise an automated coating system for numerous types of formulations, including but not limited to the application of:

- self-tanning formulations,
- sunscreens,
- suntan lotions,
- tanning accelerators,
- sunburn treatments,
- insect repellants,
- skin toners,
- skin bleaches,
- skin lighteners,
- anti-microbial compositions,
- moisturizers,
- exfoliants,
- nutriments or vitamins,
- massage aides,
- muscle relaxants,
- skin treatment agents,
- burn treatment agents,
- decontamination agents,
- cosmetics,
- wrinkle treatments or removers.

The first component of such a system is the chemical composition. The suitability of a composition for coating is strongly influenced by its viscosity, with the preferred viscosity being close to that of water (1centipoise). Compositions with viscosities in the 1 to 10 centipoise range generally atomize well, and viscosities in the 10 to 100 range can be atomized, but the resulting spray is not as fine. Higher viscosities can be atomized, and will work, but the spray is not as fine. Most currently marketed compositions of the aforementioned applications can be made suitable for atomization either as is or with appropriate dilution.

By way of example, a more detailed description of functional compositions for use in practice of the invention

6

will be based on artificial tanning compositions. Six such compositions are given in Compositions 1, 2, 3, 4, 5, and 6. Individuals skilled in this art can create other compositions.

Ingredient	%
<u>COMPOSITION 1</u>	
Dihydroxyacetone	3
Water	97
<u>COMPOSITION 2</u>	
Dihydroxyacetone	3.0
Denatured Ethanol	20.0
Water	77.0
<u>COMPOSITION 3</u>	
Dihydroxyacetone	12.0
Denature Ethanol	20.0
Water	68.0
<u>COMPOSITION 4</u>	
Dihydroxyacetone	10.0
Commercial Sunless-Thinning Lotion	15.0
Water	75.0
<u>COMPOSITION 5</u>	
Dihydroxyacetone	9.0
Commercial moisturizer	20.0
Citric acid	0.3
Commercial bath product	0.6
Bronzer	6.0
Water	64.1

By way of example, a suitable commercial moisturizer would include Vaseline Brand Intensive Care Aloe and Naturals lotion (Chesebrough-Ponds, Greenwich, Conn.), and a suitable commercial bath product would include Vaseline Brand Intensive Care Foaming Creme Bath (Chesebrough-Ponds, Greenwich, Conn.). The bronzer is a combination of FD&C dyes that yield a golden brown color.

Ingredient	%
<u>COMPOSITION 6</u>	
Bronzer	8.0
Commercial moisturizer	20.0
Commercial bath product	0.6
Ethoxydiglycol	2.0
Water	69.4

By way of example, a suitable commercial moisturizer would include Vaseline Brand Intensive Care Aloe and Naturals lotion (Chesebrough-Ponds, Greenwich, Conn.), and a suitable commercial bath product would include Vaseline Brand Intensive Care Foaming Creme Bath (Chesebrough-Ponds, Greenwich, Conn.). The bronzer is a combination of FD&C dyes that yield a golden brown color.

By way of example, suitable commercial preparations include Coppertone® Oil-Free Sunless Tanner (Schering-Plough, Memphis, Tenn.), Neutrogena® Glow Sunless Tanning Lotion for Face and Body (Neutrogena, Los Angeles, Calif.), and Kroger® Sunless Tanning Cream (Kroger, Cincinnati, Ohio).

Compositions 1, 2 and 3 are greatly simplified versions of the formulations now on the market or reported in the past. This simplification is possible due to the use of the present invention for applying compositions to skin. These simplified compositions have several advantages over more complex formulations, including:

US 6,298,862 B1

7

faster drying,  
 less potential inhibition of DHA efficacy,  
 less potential for irritation from chemical components  
 (because there are fewer components),  
 less residue on the skin,  
 less expensive,  
 more environmentally friendly.

Compositions 4 and 5 illustrate how a commercial formulation not particularly well suited for atomization can be diluted, effectively atomized and uniformly coated on human skin. Similar dilutions of products representing the other aforementioned applications can be effectively atomized and coated on human skin.

There is no pH adjustment required for these compositions, although the pH can be adjusted to alter the hue of the resulting tan and to alter the dihydroxyacetone stability. The optimal tanning occurs with DHA at a pH of below 6.0, preferably with the solution at a pH of 3.0 to 4.0. Unbuffered DHA has a pH of about 5.5. The pH on the surface of human skin is also about 5.5. Nonetheless, these formulations can be used over a wide pH range, and buffers or pH adjusters can be added.

A preferred colorant is DHA. DHA is available from Rona (Hawthorne, N.Y.). It is effective, safe, and approved by the FDA for this application. The preferred DHA concentration is 0.5% to 20%, with a more preferred range of 3.0% to 15.0%, and a most preferred range of 5% to 12%.

Numerous other colorants can also be used. Those agents include, but are not limited to:

crotonaldehyde  
 pyruvaldehyde  
 glycolaldehyde  
 glutaraldehyde  
 ortho-phthaldehyde  
 sorbose  
 fructose  
 erythulose  
 methylvinylketone  
 food coloring

Various dyes and UV blocking agents can be covalently linked to the colorant or can be mixed into the composition with the colorant.

Bronzers can also be used in combination with or as an alternative to DHA. Bronzers which can be used include, but are not limited to, lawsone and juglone. Combinations of DHA and bronzers can also be used, and can be used to modify the resulting color (hue) and intensity of the tan. The preferred range for lawsone, juglone, and FD&C dyes is 0.5% to 10.0% with the more preferred range of 1.0% to 5.0%.

Composition 6 is an example of a formulation containing only bronzers (no DHA). The preferred range of FD&C dyes in commercially formulated liquid form (e.g., food coloring by Adams Extract Co., Austin, Tex.) is 1% to 50%, with a more preferred range of 4% to 12%. Ethoxydiglycol is added to enhance the penetration of the dyes into the skin, to reduce transfer to clothing, and to assist in the stabilization of the formulation. The preferred ethoxydiglycol range is 1% to 20%, with a more preferred range of 2% to 10%.

Alcohol can be added to the composition to accelerate the rate of drying. Denatured ethanol (USP grade, commodity chemical) works well in this capacity. The preferred range for alcohol concentration is from 1.0% to 50.0%, with a more preferred range from 10.0% to 30.0%, and a most preferred concentration of 20.0%.

8

Other potential additives include:

moisturizers,  
 preservatives,  
 anti-microbials,  
 thickeners,  
 solvents,  
 emulsifiers,  
 fragrances,  
 stabilizers,  
 sunscreens,  
 surfactants,  
 pH adjusters,  
 anti-caking agents,  
 ingredients to alter the color reaction.

It typically requires about 100 ml of a 5.0% DHA composition to obtain a medium to dark tan over an entire adult body (about 2 square meters of skin). A single application of about 250 ml of a 9% dihydroxyacetone composition over an entire adult human body will result in a very dark tan. The exact amount of dihydroxyacetone required depends on the skin type and intensity of tan desired. The tan can last for about 2 to 7 days, but usually lasts for 3 to 4 days. Multiple applications will darken the tan.

The second component of the invention is the atomization of the composition. The required atomization can be obtained by a host of ways, most of which involve passing the composition through an orifice under pressure. Methods now used to atomize solutions include the use of the following systems:

air atomization  
 siphon feed  
 gravity feed  
 pressure feed  
 internal atomization  
 external atomization  
 low pressure low volume  
 high volume low pressure  
 airless atomization  
 pressurized through small orifices  
 air-assisted  
 air-assisted heated  
 electrostatic  
 using charged particles  
 heated charged particles  
 high speed rotational atomizers

ultrasonic  
 These forms of atomization are the basis for most methods of producing atomized sprays, including misting and nebulization.

Using a single airless sprayer with a tip orifice of 0.6 mm, with a circular spray pattern of 12 inches at 12 inches from the tip, and with a flow rate of approximately 400 ml/min. the entire body (excluding the bottom of the feet) of an average-sized person can be coated with solution in 5 to 15 seconds. In practice, the underside of the feet usually get slightly tanned also from exposure to small quantities of residual artificial tanning composition on the floor of the application area. The use of a single airless sprayer to apply a composition to human skin is illustrated in FIG. 2. In this figure and subsequent FIGS. 11 designates the orifice for atomization of the composition, 12 designates the atomized spray, and 13 designates the subject being sprayed. In this configuration, an operator must direct the flow of the spray. The configuration illustrated in FIG. 2 would also work for



US 6,298,862 B1

9

any of the other atomization methods aforementioned, and for any of the applications aforementioned. The preferred atomization method is the pressure-free air-atomization system, with an internal or external atomization configuration. For a person to be coated as illustrated in FIG. 2 with an artificial tanning composition (or any composition of the applications aforementioned), several precautions should be taken. First, the person should hold their breath during the application and during the time required for the spray to clear. If this process is done in an open area, the coating should take about 5 to 15 seconds and the clearing of residues should take 1 to 10 seconds. Thus, the person would need to hold their breath for 6 to 25 seconds. Alternatively, they could wear a filter over their mouth, have a filter inside of their mouth, or use a breathing tube. They can also wear nose plugs or filters. Second, the eyes should be protected even though most of these formulations are not likely to injure the eye. The simplest and most effective protection is to keep the eyes closed. Goggles or patches also work well, although they leave uncoated areas that must be subsequently coated manually. Next, precautions need to be taken if one wants to avoid the exposure of scalp hair. Scalp hair can be protected with a shower cap or any other similar protective covering impervious to the coating compositions. Also, hair can be coated with a water insoluble material such as petroleum jelly. Similar protection can be used to protect hair on any other parts of the body. Next, if atomization is from a single source, it is recommended that the person being coated turn while being coated, or that the coating apparatus be moved around the person being coated, or there be a combination of these movements. Finally, care must be taken that the nozzle remain at least several inches from the person being coated to prevent any possible injection of composition into the person. Generally, spray injection occurs at pressures greater than 500 psi with the person actually contacting the atomization orifice. The pressures here are less than 80 psi, and more typically 10 to 40 psi, and the person being coated should be a foot or more from the orifice.

The issue of what to wear during coating is usually of great concern to the person being coated. In the case of coating with artificial tanning solution, the selection of what to wear is a matter of preference for the person being coated. The subject can be coated nude, with underwear, with a bikini or a bathing suit, or with some form of pasties covering their private parts.

The third component of the invention is containment of the spray. Containment is illustrated in FIG. 3. In this figure and subsequent FIGS. 14 and 15 designate side panels and 16 and 17 designate the top and bottom panels, respectively. This type of containment is similar to the containment of spray paint using paint booths in automobile refinishing. Alternatively, spray containment can be obtained using electrostatic forces, where the atomized spray is charged and the residual charged spray is removed by activating charged collection plates. Of course, precautions must be taken so that the person being sprayed and the operator are isolated from the charged plates.

Containment of the spray is very important for several reasons. These reasons include but are not limited to:

- reducing waste,
- avoiding spray getting onto and staining items in the immediate surroundings,
- facilitating capture and recovery processes,
- better control of air flow,
- better control of temperature and humidity.

10

This type of containment facilitates the use of this invention in enclosed areas such as stores or medical facilities.

Control of air and spray flow is very important to the quality of the skin coating. It is highly preferable to have an exhaust fan drawing the spray towards the person being coated, and the residual composition out of the booth. In FIG. 4 is shown the addition of an exhaust fan 18. The fan offers several significant advantages to the invention. These advantages include but are not limited to:

- better control of air flow
- shorter exposure to residue spray, requiring less time to hold breath or breathe through filter or air line
- faster drying of the coated composition on skin
- better quality coating

The fan 18 should have a flow of 10 to 5000 cubic feet per minute per square foot of opening, preferably 50 to 1000 cubic feet per minute per square foot, and most preferably 100 to 400 cubic feet per minute per square foot. At flow rates of below 100 cubic feet per minute per square foot, the air movement is sufficient to guide the atomized spray through the containment area. At flow rates of 100 to 400 cubic feet per minute per square foot, the atomized spray is being actively drawn through the containment area and the application and drying process is enhanced. At rates above 400 cubic feet per minute per square foot, the atomized spray is being accelerated and the exhaust flow plays a much more prominent role in the application process. The flow rate of the air through the containment area is therefore a major parameter which can be varied to modify the characteristics of the coating of the artificial tanning composition to the skin. The drying time for the composition deposited on skin is also affected by flow rate, with drying time decreasing as flow rates increase. At rates above 100 cubic feet per minute per square foot, the drying time (to the point of no transfer to other surfaces upon contact) is less than 5 minutes.

At any flow rate above 10 cubic feet per minute per square foot, the residual atomized spray is completely removed from the containment area within one second. This rapid removal is important to minimize the time the person being tanned is exposed to spray and has the potential to inhale this spray. In the absence of this air flow, the residual spray lingers in the area for several minutes, and traces can be detected hours later. This vigorous flow also protects any individuals or operators near the atomizing orifices from back spray.

The final element of this invention is recovery, or filtering, of residual composition. This feature greatly enhances the utility of the invention because it allows the system to be self-contained in an indoor environment and promotes a more environmentally friendly process. Without a recovery system, there is a potential for the exhausted residue to stain anything it contacts. Also, there could be an accumulation of residue with time. One configuration of the recovery system is shown in FIG. 5. In this figure and subsequent figures, the recovery system or filter is denoted as 19. Recovery of both particulates and solvents is possible. Potential filters include a high-efficiency filter such as Binks' (Franklin Park, Ill.) Paint Pockets or Columbus Industries' (Ashville, Ohio) High-Capacity Supra Mini-Mesh, a form of a carbon filter, a water-wash filter, or an exchange-type resin. The efficiency of particulate and solvent removal should be greater than 99%. As an alternative to high-efficiency filtering, the spray residuals could be vented to the outside environment.

Additional features adding to the utility of the invention are shown in FIG. 6 and FIG. 7. In FIG. 6 there is shown the addition of a motorized turntable 20. This turntable 20 will

## US 6,298,862 B1

11

rotate the person being coated, eliminating rotation by the individual as a possible source of error or problems. It also is a major convenience for the person being coated. The preferred rate of rotation is in the range of 1 to 60 rpm, with a more preferred range of 5 to 20 rpm, with a most preferred rate of rotation of 12 rpm.

In FIG. 7 there is shown the use of multiple atomizing orifices. The use of multiple orifices facilitates the automation of this process, and reduces operator effort and potential error. It also reduces the time required to fully coat an individual. The typical round spray pattern is about 12 inches wide at 8 to 12 inches from the orifices, so a preferred spacing of multiple orifices will be 8 to 12 inches apart, but could be positioned from 1 to 48 inches apart. Fan patterns from wide-angle nozzles at 18 inches are typically 24 inches long and 9 inches wide. Using the preferred configuration, an individual can be coated in 5 seconds or less. In FIG. 7, the orifices are aligned in a vertical pattern. The coverage of more area at one time could also be obtained by rapidly moving one or more orifices along a track or by rapidly altering the angle of the orifice. Other patterns are possible, including combinations of vertical and horizontally aligned orifices. Orifices could also be aligned radially, with the subject being sprayed with orifices aligned from 0 to 360°. Another alignment is a horizontal ring containing orifices that surround the body. By vertically raising and lowering the horizontal ring, the entire body or selected parts of the body could be coated.

In an open environment, such as a beach or a park, a modified version of configuration illustrated in FIG. 7 could be used to rapidly coat an individual. It would even be possible to have a walk-through coating system. An atomized spray could be produced from multiple nozzles arranged in a single line (as shown in FIG. 7), in two single lines facing one another and about 36 to about 48 inches apart, or multiple lines of nozzles. The preferred configuration is multiple lines, with 4 lines being adequate. The atomized spray results in an area of intense atomized solution, which would coat an individual standing in that area. The residual spray would then be dissipated into the surrounding environment. A fan could be used to accelerate the removal of the residuals from the coating area.

FIG. 8 illustrates how the system of the present invention can be used to tan a selected part of the body. In this case, just the face is being tanned. In this figure the bottom panel of the apparatus 22 contains an opening through which one can insert his or her head. The top panel 23 is arched. The high-efficiency filter is 19. The fan and back panel is 18. Alternately, the setup as shown in FIGS. 2-7 could be used to tan only a select part of the body by protecting the area not desired to be tanned with appropriate barrier apparel or by screens between the atomized spray and the regions of the skin not to be coated. The barrier apparel could be any material impervious to the atomized coating composition. For example, materials appropriate for use with the aforementioned coating compositions include vinyl, polyurethane, and latex rubber. The screens can be sheets composed of any material impervious to the atomized artificial tanning compositions, including most metals or plastics. A preferred screening material is foam with an impervious aluminum foil backing. The foam is aligned with the backing away from the atomizing orifice. The foam is preferred because it absorbs much of the atomized spray, reducing back deflection.

FIGS. 9, 10, 11, and 12 illustrate an apparatus which may be utilized in the practice of the invention. The apparatus 30 comprises a unitary construction which includes both a

12

coating chamber 32 adapted to receive a person to be coated with a predetermined substance and various components utilized to effect spraying of the predetermined substance onto the person situated within the coating chamber 32.

The coating chamber 32 includes a door 34 which affords ingress to and egress from the coating chamber. The coating chamber 32 is further provided with a plurality of spray columns 36. As is best shown in FIG. 10, the spray columns 36 are located at spaced apart points around the periphery of the chamber 32. Those skilled in the art will appreciate the fact that neither the number nor the precise location of the spray columns 36 is critical to the practice of the invention, and that other spray column arrangements may be utilized in the practice of the invention, if desired.

The spray columns 36 are preferably supported for pivotal movement through predetermined arcs under the action of a pneumatic cylinder 38. In this manner the predetermined material is discharged from the spray columns 36 in such a way as to assure uniform coating of the predetermined material on a person situated within the coating chamber 32. The pneumatic cylinder 38 is connected to the pivoting mechanism of each of the spray columns 36 through a plurality of links 40.

Referring again to FIG. 9, there is further included a blower 46 which directs a flow of air upwardly along an air guide 48 and then laterally along a top panel 50 into engagement with a plurality of baffles 52. The baffles 52 direct the air from the blower 46 downwardly through the coating chamber 32, whereby the flowing air effects drying of the sprayed material and aids in recovery of the sprayed material for reuse. From the coating chamber 32 the air is directed through a plurality of filters 54 and is returned to the blower 46.

The predetermined material which is to be coated onto a person situated within the coating chamber 32 is preferably provided in the form of a liquid which is received in a reservoir 60. The interior of the reservoir 60 is pressurized by compressed air which is received from an air compressor 62 through an air tank 64. Compressed air from the air compressor 62 in the tank 64 is also directed to an air tank 66 and to a manifold 68. The air tank 66 provides compressed air for operating the pneumatic cylinder (FIG. 10). The manifold 68 directs compressed air to the spray columns 36.

Ideally, all of the liquid from the reservoir 60 which is discharged from the spray columns 36 would be received on the body of the person within the coating chamber 32. In actual practice, it is not possible to obtain 100% efficiency in the coating procedure. Excess liquid which is discharged from the spray columns moves downwardly under the action of gravity onto a drain ramp 72. A drain pump 74 receives the excess liquid through a suction pipe 76 and delivers it to an appropriate drain.

Referring to FIGS. 11 and 12, each spray column 36 includes an inner tubular passageway 84 which receives liquid from the reservoir 60 under the action of compressed air supplied by the air compressor 62 through the tank 64 and an outer tubular passageway 86 which receives compressed air from the manifold 68. Each spray column 36 is provided with a plurality of nozzles 88. Each nozzle 88 receives compressed air from the outer tubular passageway 86 through a quick disconnect 90 and receives liquid from the inner tubular passageway 84 through a quick disconnect 92. A check valve 94 prevents reverse flow of liquid back through the quick disconnect 92.

Features Contributing Significantly to the Successful Operation of an Automated Coating System for the Human Body Incorporating the Invention

Formula

The following formula is a combination of water, dihydroxyacetone, bronzer, moisturizer, surfactant, and penetration enhancer. The formula is:

		Range	Preferred
water	base	16%-65%	41.7%
dihydroxyacetone	self-tanning	3%-15%	10.0%
bronzer*	cosmetic colorant	0%-10%	8.0%
ethoxy diglycol commercial moisturizer lotion**	penetration enhancer	0%-10%	5.0%
commercial bath product***	film former, viscosity	10%-25%	15.0%
citric acid	surfactant	0%-2%	0.6%
10x aloe vera concentrate	pH adjustment	0.1%-1.0%	0.2%
isopropyl alcohol with methyl salicylate	moisturizer, tan enhancer	1%-5%	2.5%
Trivisol®	solvent, penetration enhancer emulsifier	5%-25%	15%
		5%-10%	2%

\*By way of example, a suitable bronzer would be a combination of the following food dyes provided by Adams Extract Company, Austin Texas: 4 parts red, 2 parts yellow, 1 part green, and 3 parts purple.

\*\*By way of example, a suitable commercial moisturizer lotion includes Vaseline Intensive Care Lotion (Aloe Vera Triple Action Formula, Chesebrough-Ponds, Greenwich, CT).

\*\*\*By way of example, a suitable commercial bath product includes Vaseline Intensive Care Foaming Cream Bath (Chesebrough-Ponds, Greenwich, CT).

Foot Shields

The feet are one of the most difficult parts of the body to coat uniformly. This difficulty is due in large part to the irregular structure of feet. Also, the downward motion of the atomized mist, both by gravity and from air currents, tends to cause the mist to settle on the tops of the feet. Therefore, the feet are provided with shields to assure a more uniform coating of the feet. The shields may take the form of a large, bottomless shoe. The shields produce a silhouette effect from the top of the feet to the toes. Holes and openings are provided in the shields which are located 0.25 to 2 inches from the feet, allowing the mist to result in a silhouette effect rather than defined lines.

Air Shield to Deflect Air Away From the Feet

To reduce the amount of mist settling on the feet, a plastic shield shaped like a figure eight is placed between the fleximat flooring the user stands on and the metal grating supporting the fleximat. Dimensions of the figure eight are two 18 inch diameter overlapping circles with a total width of 26 inches. The total width can vary from 18 inches to 36 inches, and the circle diameters can vary from 12 inches to 20 inches.

Toweling Buffing After Coating

After coating it is advantageous to use a towel rub to buff over the entire body to yield a more uniform coating and to remove any areas of excess. The toweling yields a more cosmetically pleasing result and reduces transfer to clothing. It is preferred to towel using long, light strokes. A cotton bath towel 16 inches by 32 inches may be used. The towel could vary from a hand cloth (8"x8") to a large beach towel (18"x48). Care must be taken not to rub so hard or too much as to rub off the coating (or tan). Basically, the weight of the preferred towel is adequate, without additional pressure.

Stance During Coating

The stance used during the coating is important. After trial and evaluation of numerous methods, it has been discovered

that the "ballerina stance" seems to work best. Key elements of the stance are:

- hands over the head
- preferred 2 inches
- lower limit—hands touching head
- upper limit—arms extended fully up
- hands parallel to the floor
- hands could be, but not recommended to be, perpendicular to floor in a praying stance, or facing downwardly
- feet separated about 12 inches
- to allow mist to coat inside of legs
- feet are flat on flooring
- use of feet shields as described above

Hair Net

Although the above-described self-tanning solution does not turn hair orange, it may accumulate on hair. To avoid this accumulation, the user can wear a hair net or bouffant. Preferred compositions for the hair net include a cloth or plastic mesh or a continuous plastic sheet.

Barrier Cream

It has been discovered that the commercial barrier cream produced by GoJo blocks the tanning solution from the skin. During the coating process, this lotion can be used to prevent tanning of specific areas, such as the palms of the hands.

High Efficiency Filter

The use of high efficiency filters to remove excess mist is important. Preferably, a Binks high-efficiency paint-pockets filter is used.

Recharging of Filter

It has been discovered that the tanning solution trapped in the filter can be removed with a water rinse. The solution, which is water soluble, is flushed out using water that is backwashed (water applied to the top surface opposite of the surface facing the solution) or water, preferably under moderate (greater than 60 psi) pressure, that is bosed on the filtered surface.

Uniform Air Flow

Uniformity of air flow is very important to assure that the mist continues to be applied uniformly over the body even after the pressurized spray stops. Air flow parameters are, in the downward motion:

most preferred	100 cfm
next preferred	50 cfm to 200 cfm
next preferred	25 cfm to 300 cfm

Warming of Air

Atomization of liquids as done here by the nozzles results in a significant reduction in liquid temperature (as much as 20° F.). To keep the temperature to a warm, pleasant experience, four halogen lamps (250 watts each) can be added to the system to provide both illumination and heat. A coating chamber temperature of 80° F. to 110° F. is preferred, with 90° F. to 100° F. being more preferred. Other heating devices include infrared lamps and electrical heating elements.

EXAMPLES

Example 1

A twenty year old female of type III skin tanned by this process. She first applied a heart shaped sticker on her right arm. She covered her hair with a nylon mesh hair net and applied barrier cream over the palms of her hands. She

## US 6,298,862 B1

15

tanned in the coating chamber. The formula above was coated for 7 seconds. About 300 grams of solution was applied during such time. There was a subsequent 7 second period in which the mist was circulated in the booth. The residual mist was removed from the booth and the subject dried for about 45 seconds. The subject then removed any excess lotion with a towel. The final result was that the subject was 1 to 2 shades darker after tanning. This difference was especially apparent when comparing the area under the sticker with the area with no sticker. The initial color was mainly from the bronzer, and is a deep brown color. Color was much more intense the next day, when the color was at least two shades darker than before tanning. After the subject showered, the intensity was dropped to about 1 shade darker than prior to tanning. This color, which was mainly from the dihydroxyacetone, was goldenbrown. The color persisted about 1 shade darker for 3-4 days, and noticeable color was present for 7 days.

## Example 2

A forty-seven year old male with type II skin tanned by this process. He first applied a heart shaped sticker on his right arm. He covered his hair with a nylon mesh hair net and applied barrier cream over the palms of his hands and the bottoms of his feet. He tanned in the coating chamber. The formula above was coated for 7 seconds. About 300 grams of solution was applied during time. There was a subsequent 7 second period in which the mist was circulated in the booth. The residual mist was removed from the booth and the subject dried for about 45 seconds. The subject then removed any excess lotion with a towel. The final result was that the subject was about 1 shade darker after tanning. This difference was especially apparent when comparing the area under the sticker with the area with no sticker. The initial color was mainly from the bronzer, and is a deep brown color. Color was much more intense the next day, when the color was one to two shades darker than before tanning. After the subject showered, the intensity was dropped to about 1 shade darker than prior to tanning. This color, which was mainly from the dihydroxyacetone, was goldenbrown. The subject repeated the tanning process again later the second day. This time, the initial tan from the combination of previous tan and new bronzer was about 2 shades darker than before. Even after showering the next day, the tan was about two shades darker than prior to initially tanning. The color persisted about 2 shades darker for 3-4 days, and noticeable color was present for 10 days.

## Example 3

A 24 year old female with type II skin tanned as described in examples 1 and 2 for five consecutive days. The results were a highly uniform, very dark tan. Her skin color was about 3 shades darker by the end of the week. The color was golden brown. The color remained 2 to 3 shades darker for about 4 days, and some color (about 1 shade) was observed after 7 days.

## DISCOVERIES

## Very Fast Drying

Traditional sunless tanning products require 20 minutes or more to dry. The sunless tanning composition of the present invention dries within a minute after use.

## Less Transfer to Clothing Than Expected

16

Traditional sunless tanning products do not contain bronzers because bronzers transfer to clothing and other fabrics. The present invention exhibits almost no such transfer.

## Tan Hue Less Orange Than Expected

The combination of bronzers, tan enhancers, and a super application process produces a long lasting, golden brown color.

## Hair is Not Turned Orange

Self-tanning lotions have been reported to turn body hair orange. The formulation and application of the present invention do not cause the hair to turn orange. First, the formulation does not penetrate the hair, but rather beads up on it. Next, it is applied in a very thin coat. The net result is that the hair does not turn orange.

## Produces a Very Uniform Tan

The present invention facilitates the application of a thin, uniform film over the entire body. Streaking and spotting are rarely observed. Consequently, the resulting coating and tan is far superior to manual application methods.

## Bronzer Tends to Last Longer Than Expected

The bronzer provides immediate color and a method for observing the uniformity of the tan. The uniformity of the bronzer application is greatly enhanced because it is applied in a uniform thin film and its substantivity is enhanced because of deeper penetration into skin with the presence of a penetration enhancer.

## Use of Ethoxy Diglycol as a Penetration Enhancer Makes the Tan Last Longer and More Uniform

With the use of ethoxy diglycol, the duration of uniform intense tan has increased from an average of about 2 days to an average of about 4 days, and some color persists for up to 14 days.

Referring to FIG. 13, there is shown an apparatus for coating the human body 100 which may be utilized in the practice of the invention in lieu of the apparatus shown in FIGS. 9-12, inclusive. The apparatus 100 comprises an enclosure 102 having a barrier 104 disposed therein. One or more fogging nozzles 106 are utilized to generate a fog comprising a composition to be coated on all or part of the human body. As used herein, the term "fog" means liquid droplets which are small enough in size and light enough in weight to be entrained in and transported by moving air.

The fogging nozzles 106 are conventional in construction and operation. The fog generated by the fogging nozzles is similar to the insecticide fog which is generated by commercially available insect foggers. Other types and kinds of fogging devices are also well known and may be used in the practice of the invention.

The apparatus 100 further comprises a fan 110. The fan 110 causes air to flow within the enclosure 102 in a circular path around the barrier 104. The fog generated by the fogging nozzles 106 is entrained in the moving air and is transported thereby in the circular path as defined by the arrows in FIG. 13. Any droplets emanating from the fogging nozzles 106 which are too big and/or too heavy to be entrained in the moving air fall onto and are retained by an absorbent filter 112.

The enclosure 102 defines a coating zone 114 situated on the opposite side of the barrier 104 from the fan 110. A person P to be coated stands within the coating zone 114. Upon operation of the fan 110 and the fogging nozzles 106,

US 6,298,862 B1

17

the fog comprising the composition to be coated envelopes the person P and is uniformly deposited on all or part of the body of the person P.

A filter 116 is normally positioned as shown in full lines in FIG. 13. This allows air and fog entrained therein to move around the circular path as identified by the arrows in FIG. 13 under the action of the fan 110. Whenever a particular coating operation has been completed, a fluid powered cylinder 118 is actuated to pivot the filter 116 into the position illustrated in dashed lines in FIG. 13. The fan 110 continues to operate thereby causing the fog entrained in the moving air to be captured by the filter 116. After all of the fog has been captured by the filter 116, the apparatus 100 is ready for a subsequent coating operation.

Referring to FIG. 14, there is shown an apparatus for coating all or part of the human body 130 comprising the variation of the apparatus 100 shown in FIG. 13 and described hereinabove in connection therewith. The apparatus 130 comprises a housing 132 having a barrier 134 disposed therein. One or more fogging nozzles 136 are positioned in the upper portion of the housing 132. In use, the fogging nozzles 136 function to generate a fog comprising a composition to be coated on all or part of the human body.

A fan is positioned within the housing 132 and functions to cause air to flow through the housing 132 and around the barrier 134 in the direction of the arrows shown in FIG. 14. The fog comprising the composition to be coated which is generated by the fogging nozzles 136 is entrained in the moving air and is transported thereby through the housing 132 in the direction of the arrows. Any droplets emanating from the fogging nozzles 136 which are too large and/or too heavy for entrainment in the moving air are captured by an absorbent filter 142.

A door 143 provides access to a coating zone 144 situated within the housing 132. The fog comprising the composition to be coated passes through the coating zone 114 under the action of the fan 140, thereby completely enveloping the body of a person P situated within the coating zone. In this manner, the composition comprising the fog generated by the fogging nozzles 136 is uniformly distributed over all or part of the body of the person P situated within the coating zone 144.

At the end of a coating session, excess fog, that is, coating composition which was not received on the body of the person P, is directed into an absorbent filter 146 under the action of an exhaust fan 148. After the interior of the housing 132 has been cleared of excess coating composition, the apparatus 130 is ready for a subsequent coating operation.

Referring to FIG. 15, there is shown an apparatus for coating all or part of a human body 160. The apparatus 160 incorporates numerous component parts which are substantially identical in construction and function to component parts of the apparatus 130 illustrated in FIG. 14 and described hereinabove in conjunction therewith. Such identical component parts are designated in FIG. 15 with the same reference numerals utilized above in the description of the apparatus 130.

The apparatus 160 differs from the apparatus 130 in that the fogging nozzles 136 of the apparatus 160 are mounted on vertically oriented tubular columns 162. The columns 162

18

are supported for pivotal movement about vertical axes, and are interconnected by a linkage 164. The linkage 164 is operated by an actuator 166 which functions to continuously pivot the columns 162 and the fogging nozzles 136 carried thereby back and forth about their respective vertical axes. Thus, the actuator 166 and the linkage 164 operate similar to the cylinder 38 and the linkage 40 of FIG. 10.

In the operation of the apparatus 160, the fan 140 circulates air through the housing 132 and around the barrier 134 in the direction of the arrows of FIG. 15. The fogging nozzles 136 function to generate a fog comprising a composition to be coated on all or part of the human body. The fog is entrained in the moving air and is transported thereby through the housing 132.

As the fogging nozzles 136 function to generate a fog from the coating composition, the fogging nozzles 136 are pivoted in horizontal planes by the actuator 166, the linkage 164, and the vertically disposed columns 162. In this manner the initial distribution of the fog generated by the fogging nozzles 136 is turbulent rather than linear. Turbulence of the fog within the coating zone 144 of the housing 132 is beneficial in that it further assures a uniform distribution of the coating composition over all or part of the body of a person situated within the coating chamber.

Although preferred embodiments of the invention are illustrated in the Drawings and described in the Detailed Description, it will be understood that the invention is not limited to the embodiments disclosed, but is capable of numerous modifications and rearrangements of parts and elements without departing from the spirit of the invention.

What is claimed is:

1. An apparatus for coating at least a portion of the human body with a predetermined coating composition comprising: an enclosed coating chamber for receiving a person to be coated; at least one fan for directing a flow of air through the coating chamber; at least one fogging nozzle for forming the predetermined coating composition into a fog comprising droplets sufficiently small in size and light in weight for entrainment in the air flow caused by the fan and for circulation by the flowing air through the coating chamber and onto the skin of a person situated therein; and at least one filter for capturing fog generated by the fogging nozzle which is not received on the skin of the person situated within the coating chamber.
2. The apparatus according to claim 1 further including an absorbent filter positioned to receive droplets emanating from the fogging nozzle which are too large for entrainment in the flowing air.
3. The apparatus according to claim 1 wherein the coating composition is a predetermined suntanning composition.
4. The apparatus according to claim 1 wherein the coating composition is a predetermined tanning accelerator composition.
5. The apparatus according to claim 1 wherein the coating composition is a predetermined sunburn treatment composition.
6. The apparatus according to claim 1 wherein the coating composition is a predetermined insect repellent composition.
7. The apparatus according to claim 1 wherein the coating composition is a predetermined skin toner composition.

US 6,298,862 B1

19

8. The apparatus according to claim 1 wherein the coating composition is a predetermined skin bleach composition.

9. The apparatus according to claim 1 wherein the coating composition is a predetermined skin lightening composition.

10. The apparatus according to claim 1 wherein the coating composition is a predetermined anti-microbial composition.

11. The apparatus according to claim 1 wherein the coating composition is a predetermined moisturizer composition.

12. The apparatus according to claim 1 wherein the coating composition is a predetermined exfoliant composition.

13. The apparatus according to claim 1 wherein the coating composition is a predetermined nutrient and vitamin composition.

14. The apparatus according to claim 1 wherein the coating composition is a predetermined massaging aide composition.

20

15. The apparatus according to claim 1 wherein the coating composition is a predetermined muscle relaxant composition.

16. The apparatus according to claim 1 wherein the coating composition is a predetermined medicated skin treatment composition.

17. The apparatus according to claim 1 wherein the coating composition is a predetermined burn treatment composition.

18. The apparatus according to claim 1 wherein the coating composition is a predetermined decontamination composition.

19. The apparatus according to claim 1 wherein the coating composition is a predetermined cosmetic composition.

20. The apparatus according to claim 1 wherein the coating composition is a predetermined wrinkle treatment composition.

\* \* \* \* \*



US006474343B2

(12) **United States Patent**  
**Laughlin**

(10) Patent No.: **US 6,474,343 B2**  
(45) Date of Patent: **\*Nov. 5, 2002**

(54) **METHOD OF AND APPARATUS FOR AUTOMATICALLY COATING THE HUMAN BODY**

(58) Field of Search ..... 132/200, 333;  
424/401, 59, 78.02, 78.03, 78.06

(75) Inventor: **Thomas J. Laughlin, Grapevine, TX (US)**

(56) **References Cited**

(73) Assignee: **Laughlin Products, Inc., Grapevine, TX (US)**

**U.S. PATENT DOCUMENTS**

(\*) Notice: Subject to any disclaimer, the term of this patent is extended or adjusted under 35 U.S.C. 154(b) by 0 days.

This patent is subject to a terminal disclaimer.

870,766 A	11/1907	Eaton	
1,262,638 A	4/1918	Class	
1,982,509 A	11/1934	Frank	128/1
2,700,384 A	1/1955	Ivory	128/204
2,949,403 A	8/1960	Andreadis et al.	167/90
3,868,950 A	3/1975	Kato	128/66
4,749,130 A	6/1988	Utzing	239/543
4,832,943 A	5/1989	Grolier et al.	424/59
5,460,192 A	10/1995	McClain	132/333
5,664,593 A	9/1997	McClain	132/333
6,199,557 B1 *	3/2001	Laughlin	132/200
6,298,862 B1 *	10/2001	Laughlin	132/200

(21) Appl. No.: **09/976,382**

(22) Filed: **Oct. 11, 2001**

(65) **Prior Publication Data**

US 2002/0040721 A1 Apr. 11, 2002

**Related U.S. Application Data**

(63) Continuation of application No. 09/874,466, filed on Jun. 4, 2001, which is a continuation of application No. 09/751,752, filed on Dec. 29, 2000, now Pat. No. 6,305,384, which is a continuation of application No. 09/294,689, filed on Apr. 19, 1999, now Pat. No. 6,199,557, which is a continuation-in-part of application No. 08/946,764, filed on Oct. 8, 1997, now Pat. No. 5,922,333.

(51) Int. Cl.<sup>7</sup> ..... **A45D 24/00; A45D 44/00; A61K 6/00; A61K 7/42**

(52) U.S. Cl. .... **132/200; 132/333; 424/401; 424/59; 424/78.02; 424/78.03**

\* cited by examiner

*Primary Examiner*—John J. Wilson  
*Assistant Examiner*—Robyn Kieu Doan  
(74) *Attorney, Agent, or Firm*—Michael A. O'Neil

(57) **ABSTRACT**

In a system for coating human skin, a chemical composition, such as a cosmetic or medical formulation, is uniformly coated over the entire body or selected parts of the body of the person being coated. The system includes atomization of the coating composition, containment of the atomized spray, and residual recovery which together yield a novel method for applying chemical compositions.

**6 Claims, 7 Drawing Sheets**

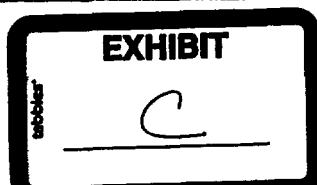
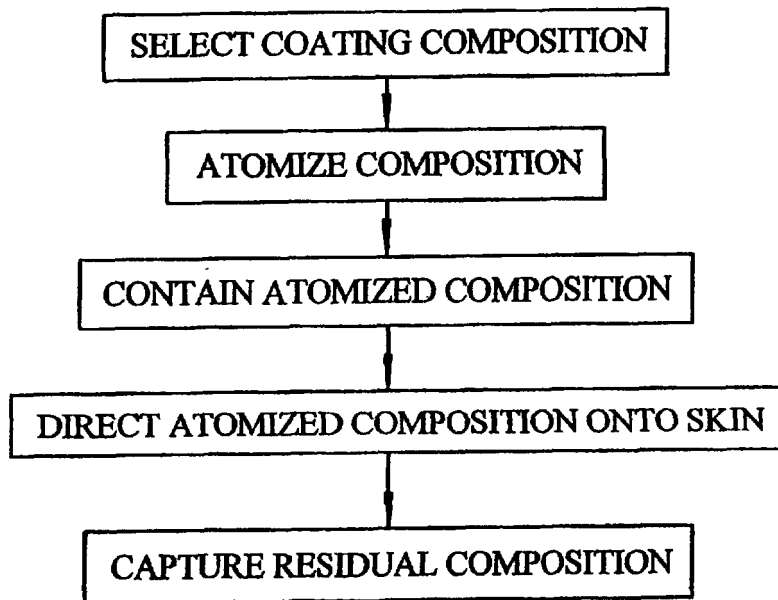

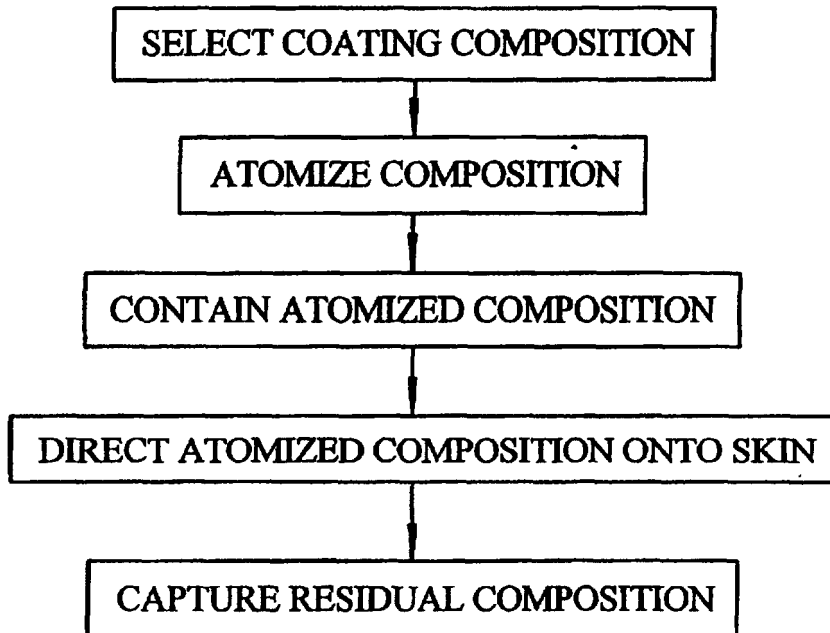

*Fig. 1*

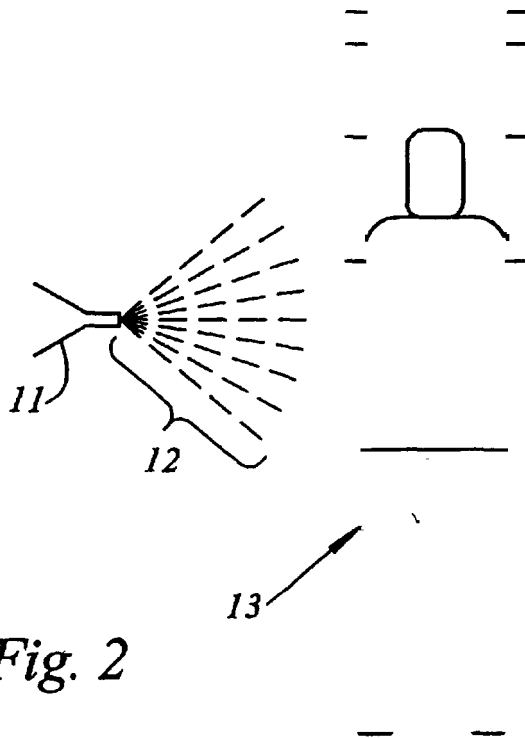

*Fig. 2*



**U.S. Patent**

**Nov. 5, 2002**

**Sheet 2 of 7**

**US 6,474,343 B2**

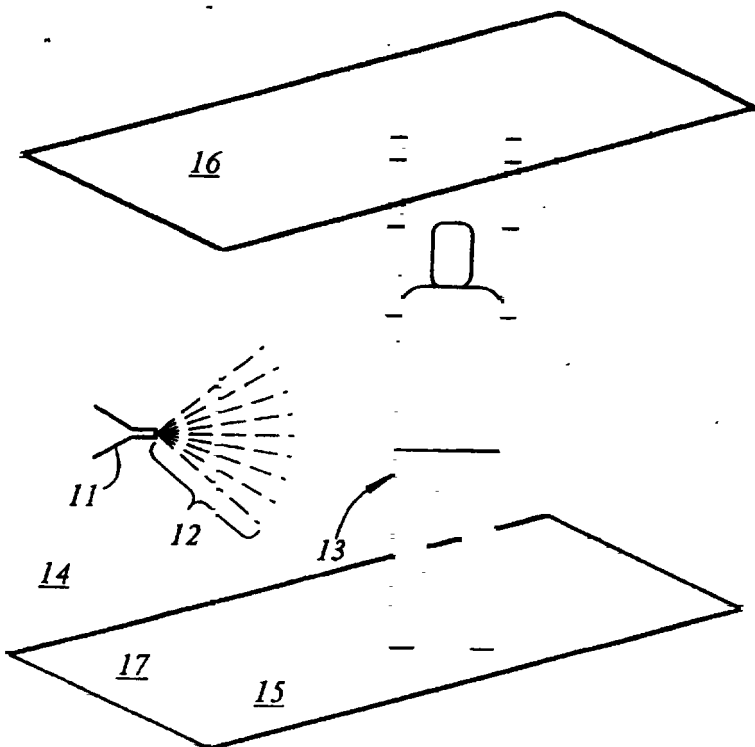

*Fig. 3*

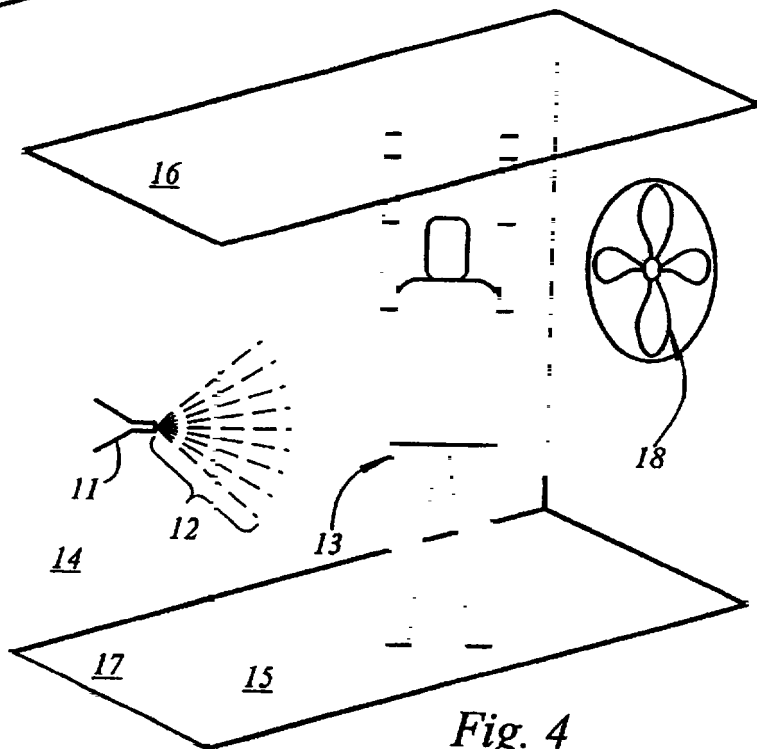

*Fig. 4*

**U.S. Patent**

Nov. 5, 2002

Sheet 3 of 7

**US 6,474,343 B2**

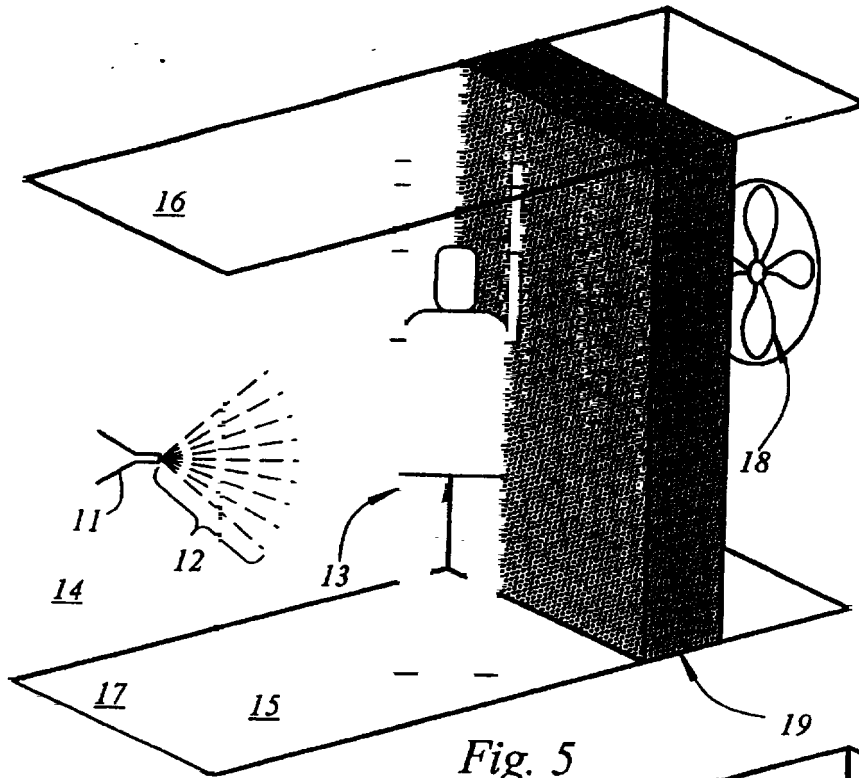

*Fig. 5*

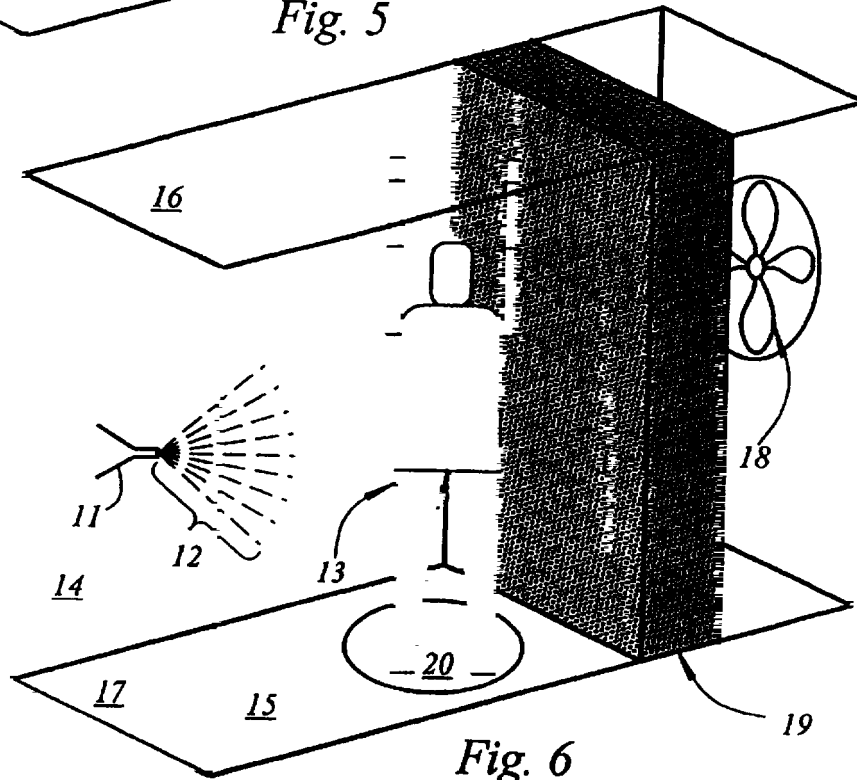

*Fig. 6*

U.S. Patent

Nov. 5, 2002

Sheet 4 of 7

US 6,474,343 B2

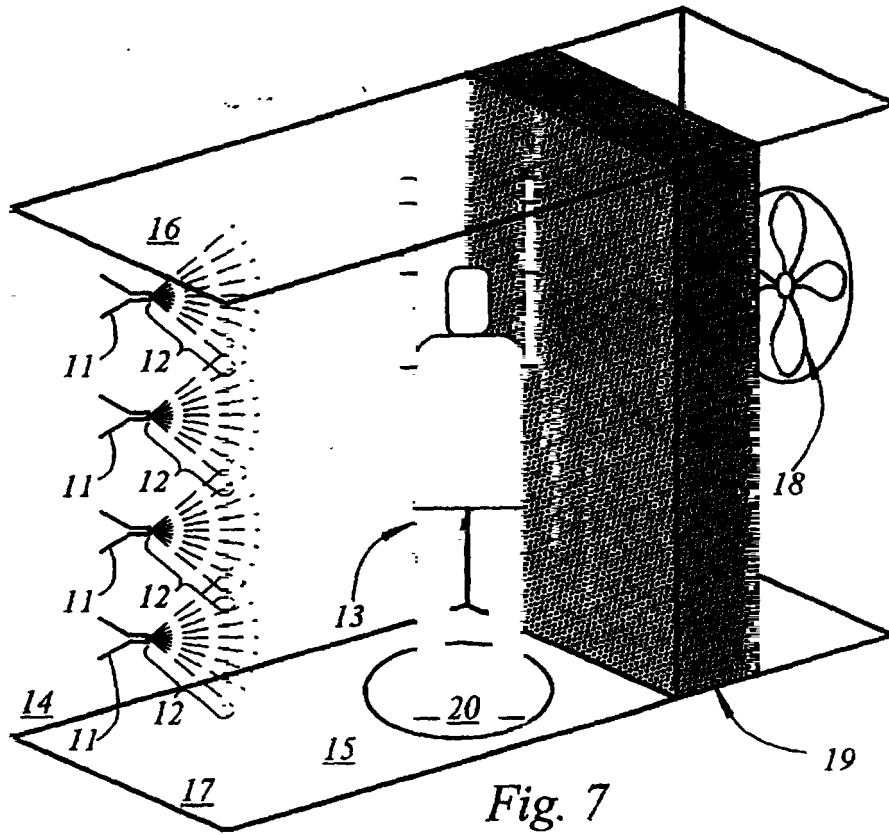

Fig. 7

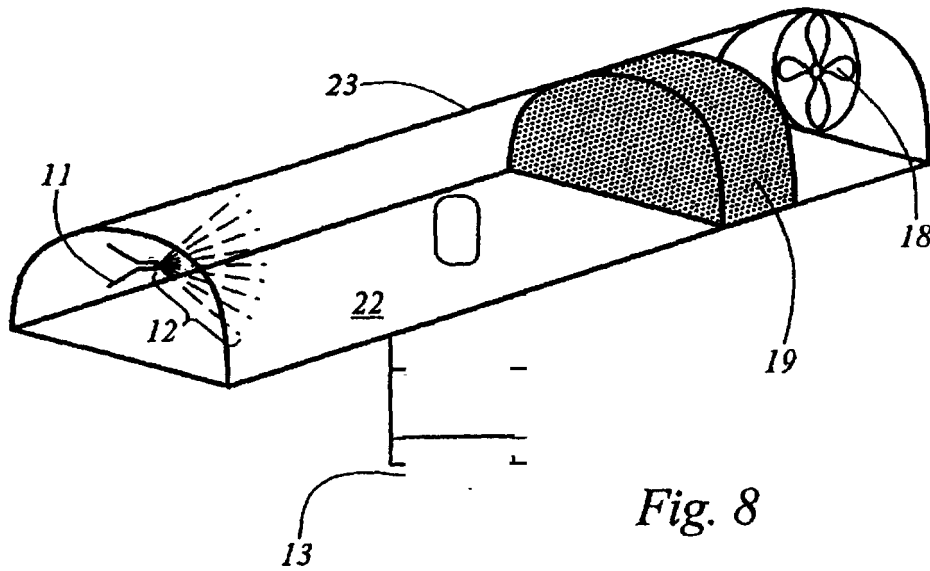

Fig. 8

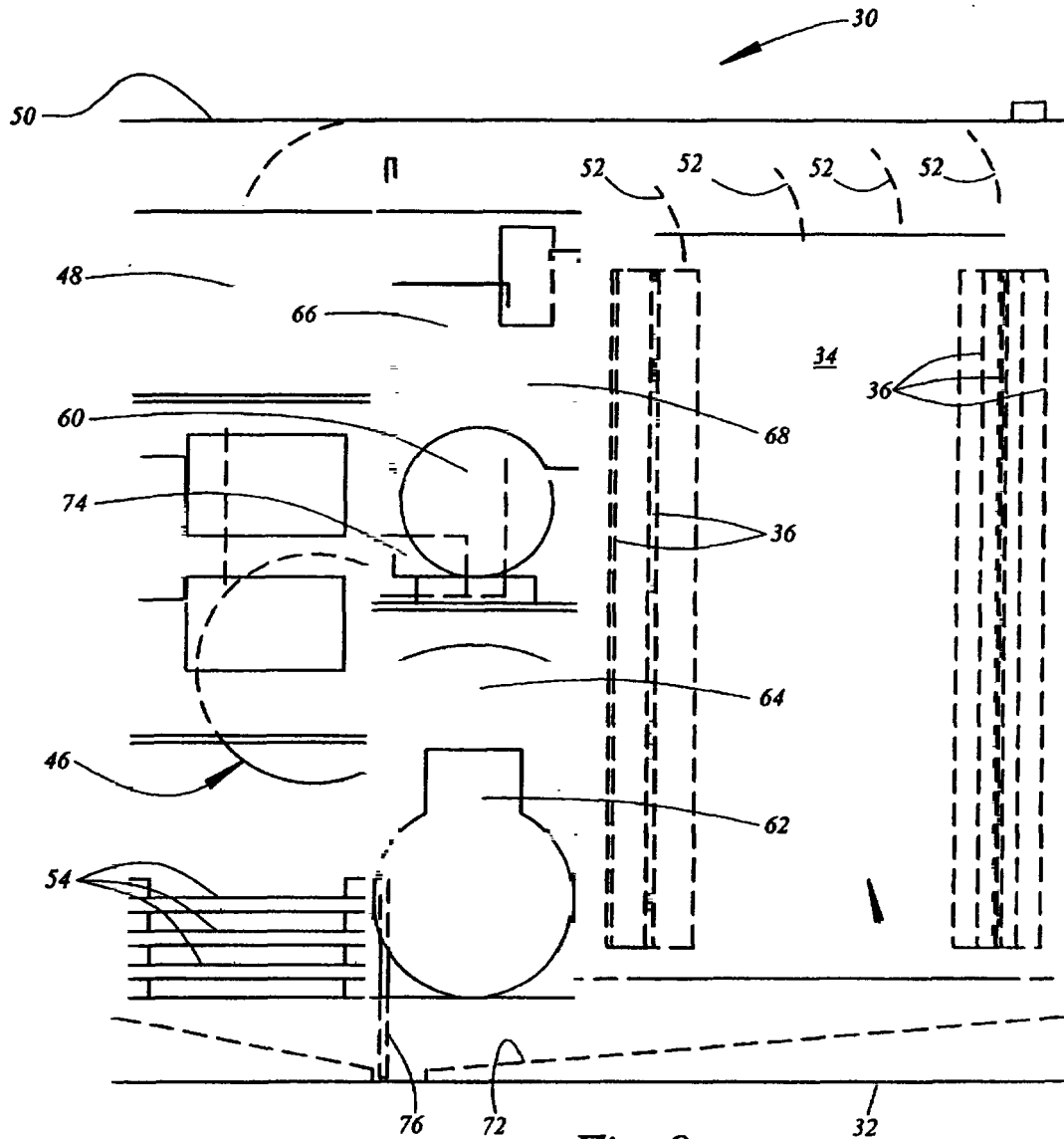

Fig. 9

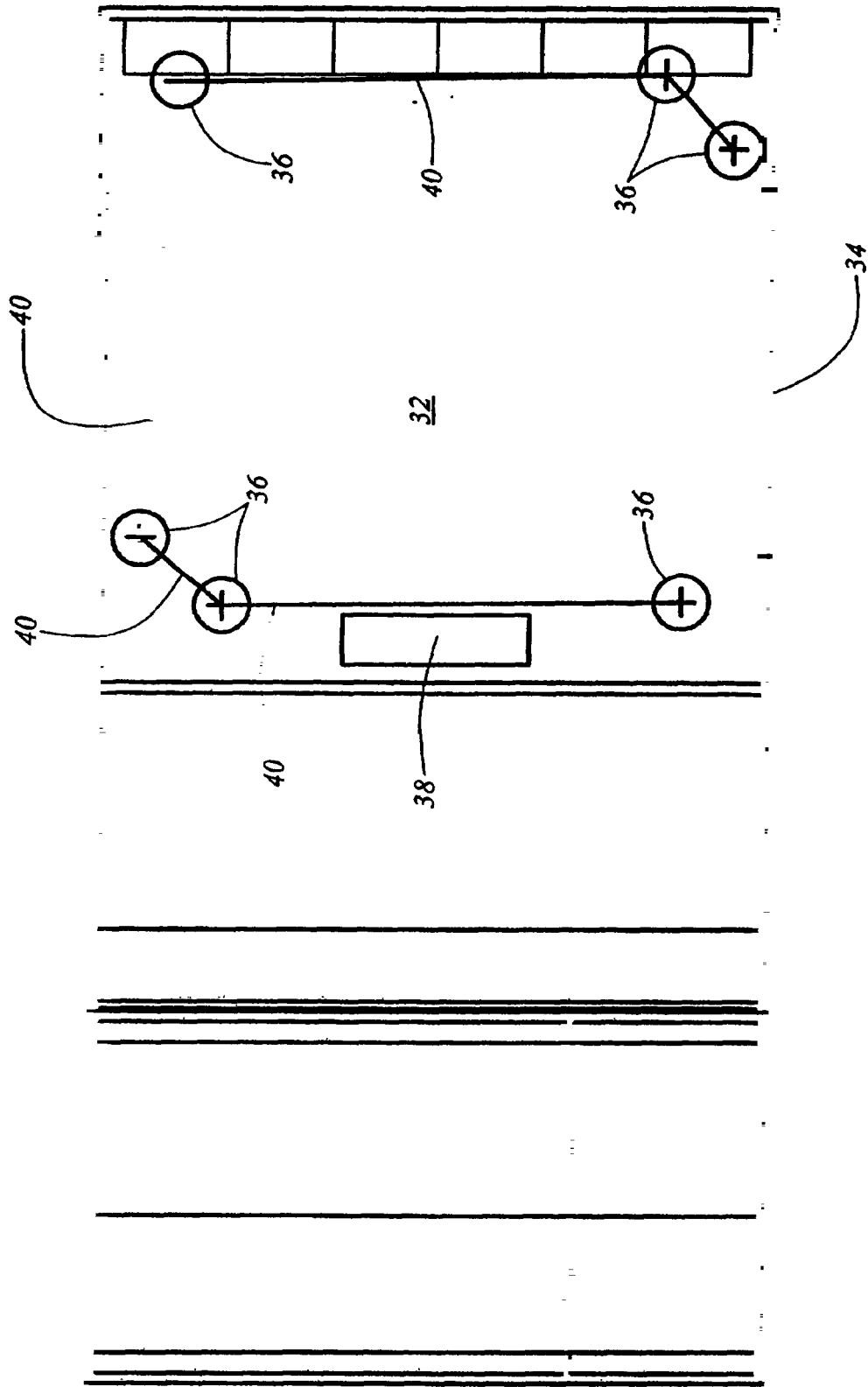

Fig. 10

U.S. Patent

Nov. 5, 2002

Sheet 7 of 7

US 6,474,343 B2

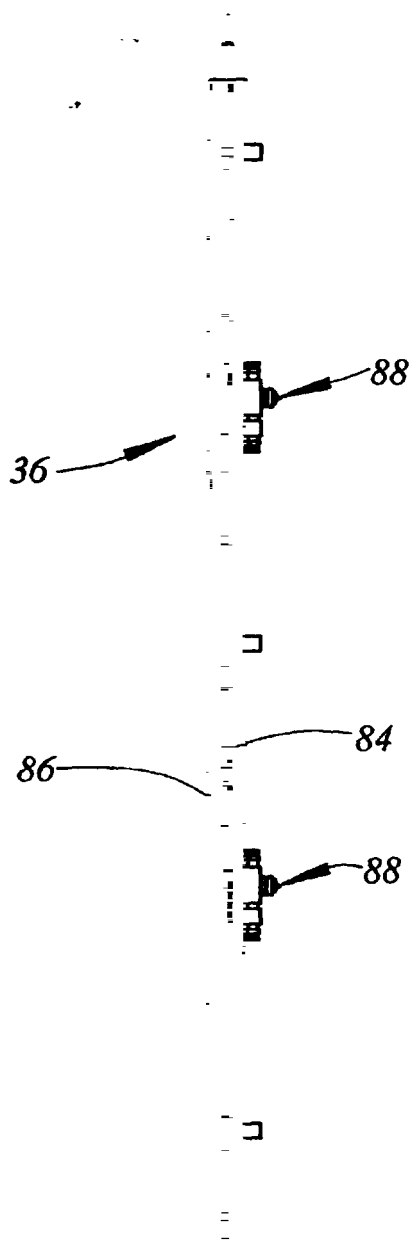

Fig. 11

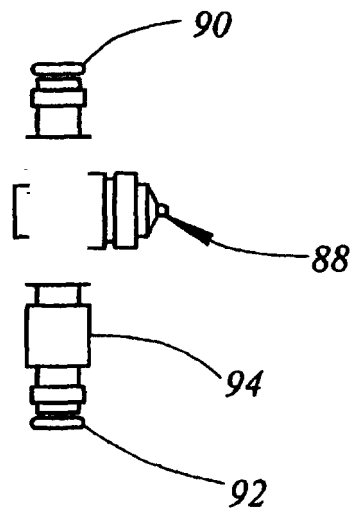
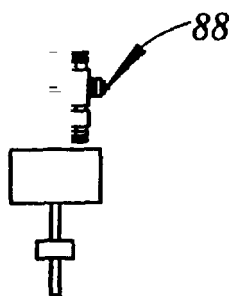

Fig. 12

US 6,474,343 B2

1

**METHOD OF AND APPARATUS FOR  
AUTOMATICALLY COATING THE HUMAN  
BODY**

**CROSS-REFERENCE TO RELATED  
APPLICATION**

This application is a continuation of application Ser. No. 09/874,466, filed Jun. 4, 2001, currently pending, which is a continuation of application Ser. No. 09/751,752, filed Dec. 29, 2000, now U.S. Pat. No. 6,305,384, which is a continuation of application Ser. No. 09/294,689, filed Apr. 19, 1999, now U.S. Pat. No. 6,199,557, which is a continuation-in-part of application Ser. No. 08/946,764 filed Oct. 8, 1997, now U.S. Pat. No. 5,922,333.

**TECHNICAL FIELD**

The present invention relates generally to systems for automatically coating the human body or selected parts thereof with predetermined fluids. More particularly, the invention relates to an automated self-tanning system.

**BACKGROUND OF THE INVENTION**

The application of various fluids to all or selected parts of the human body has been known literally for centuries. However, despite the long standing and wide spread practice of coating the human body with various fluids, there has never been a successful way of automatically coating the human body. Therefore, prior to the present invention, it has been necessary to apply fluids to the body manually.

Manual application of fluids to the human body results in numerous disadvantages. First, it is almost impossible to uniformly coat the human body with fluids using manual application techniques. This is true even in the case of fluids that are provided in aerosol or spray form because such fluids must be rubbed in after application. Second, the application of fluids to certain parts of the human body, for example, the back, require the availability of an assistant in order that proper manual application can be attempted.

The foregoing difficulties are particularly apparent in the case of artificial tanning processes. Artificial tanning has been known for more than 40 years, with artificial tanning products appearing on the U.S. market as early as 1959. The two key types of tanning processes are by colorants and bronzers.

Tanning by colorants is based on the color reaction which occurs between components of the skin and the colorant. The most commonly used chemical for artificial tanning is dihydroxyacetone (DHA). It is widely used in commercial artificial tanning products, and is recognized as safe and effective by the U.S. Food and Drug Administration (FDA). DHA reacts solely with the stratum comeum. It interacts with amines, peptides and free amino acids to generate a Maillard reaction. The resulting products are cyclic and linear polymers that have a yellow or brown color.

Two common bronzers are juglone and lawsone. Both are naphthoquinones. When applied to skin, lawsone produces an orange hue and juglone produces a greenish-brown tan. They are sometimes used in combination with DHA to modify the color or hue of the tan or to intensify the color.

Numerous forms of artificial tanning products are now on the market. They include:

- lotions,
- creams,
- gels,

2

oils,  
sprays.  
These products are mixtures of a chemically-active skin colorant or a bronzer with combinations of the following:

- 5 moisturizers,
- preservatives,
- antimicrobials,
- thickeners,
- 10 solvents,
- emulsifiers,
- fragrances,
- surfactants,
- 15 stabilizers,
- sunscreens,
- pH adjusters,
- anti-caking agents,
- 20 ingredients to alter the color reaction.

Users of these products often experience significant problems associated with the current methods for applying artificial tanning formulations to skin. These problems include the following.

25 If not properly dried, the formulation will streak or form blotches with time. The net result is a very nonuniform tan, with light or dark streaks or blotches.

Certain parts of the body will stain more intensely when the formulation is spread manually. This differential staining is due to enhanced absorption of certain skin tissue and the tendency of certain tissue to retain more formulation. The result is that as the formulation is being spread manually, certain tissue absorb or trap more formulation (e.g., the wrinkles in the elbows and knees and the dense tissue in the palms).

30 Most products designed for manual application require components such as thickeners and polymers, which often inhibit the efficacy of DHA.

Current formulations typically take about 20 minutes to dry to the touch, and about 1 hour before not transferring from skin to textiles.

Application of artificial tanning products is additionally complicated by the tendency of these formulations to stain materials containing amine molecules, including certain fabrics, certain types of carpet, and certain wall coverings and paint.

35 In spite of all of these problems, artificial tanning is becoming increasingly popular. It is apparent that a need exists for a superior application system which solves the foregoing problems.

There is also a need for a superior applications system for many other applications, including but not limited to:

- self-tanning formulations,
- sunscreens,
- 55 suntan lotions,
- tanning accelerators,
- sunburn treatments,
- insect repellants,
- 60 skin toners,
- skin bleaches,
- skin lighteners,
- anti-microbial compositions,
- 65 moisturizers,
- exfoliants,
- nutriments or vitamins,

US 6,474,343 B2

3

massage aides,  
muscle relaxants,  
skin treatment agents,  
burn treatment agents,  
decontamination agents,  
cosmetics,  
wrinkle treatments or removers.

There are specific and significant problems with the manual coating of each of these products. The artificial tanning application provides a good illustration of the types of problems normally encountered when manually coating these products. Artificial tanning is also one of the most demanding applications in that uniformity of the coating is critical to assure uniform tanning.

### SUMMARY OF THE INVENTION

The present invention comprises a system for automatically coating the human body, including a method of and apparatus for uniformly and rapidly coating all or selected parts of the human body. The system includes apparatus which atomizes (also referred to as aerosolization, nebulization, mist generation, fog generation or spray generation) a chemical composition and deposits it uniformly over all or selected parts of the human body. It is not necessary for the individual receiving the treatment nor anyone else to manually apply any of the formulation. Also, a containment system is provided which restrains and collects residue from the application process. The system can optionally recycle the materials used.

There are several major advantages resulting from the use of the invention:

- Uniform application minimizes or eliminates streaking,
- No assistant is required for applying the composition,
- The entire skin surface receives the same exposure to the composition, so the uniformity of the coating is greatly enhanced over manual application,
- The optimal formulation for atomization is very simple, and does not require the addition of components which may inhibit the efficacy of the applied material,
- The application time can be as quick as a few seconds, and complete drying can occur in just a few minutes,
- The containment system drastically reduces the unwanted environmental impact,
- Multiple applications can be used to better control the amount of material applied per unit area, and additional substances can be applied in separate applications.

The invention may be practiced utilizing a unitary construction including both a coating chamber and apparatus for coating a person situated within the coating chamber. A door provides ingress to and egress from the coating chamber which is provided with vertically disposed arrays of spray discharging nozzles situated at spaced apart points around the periphery of the chamber. A blower circulates air through the coating chamber to effect drying following the coating procedure and to aid in containment of excess spray. An air compressor supplies liquid for coating and compressed air for spraying the coating liquid to the nozzles situated within the coating chamber.

4

### REFERENCES

REFERENCES			
5 U.S. patent documents			
3,932,151	January 1976	Lau	55/229
4,231,289	November 1980	Domiceit	98/115
5,268,166	December 1993	Barnett	424/047
Foreign patent documents			
10 WO 94/12146	June 1994	PCT Int'l Appl.	
Other publications			

- Akins, F. J. and Marlowe, E., "Non-Carcinogenicity of Dihydroxyacetone by Skin Painting," *Journal of Environmental Pathology and Toxicology*, 5: No. 5, pp.349-351 (1984).
- Federal Register, "Color Additive Dihydroxyacetone" 38: No. 148, p. 21615, Aug. 2, 1973.
- 20 Futierer, E., "Theory and Practice of Artificial Tanning: Literature and Patent Survey," *Cosmetics and Perfumes*, 88: No. 8, pp. 31-33 (1973).
- Johnson, J. A. and Fusaro, R. M., "Persistence of Skin Color and Fluorescence after Treatment with Dihydroxyacetone," *Dermatology* 188: pp. 247 (1994).
- 25 Kurz, T., "Formulating Effective Self-Tanners with DHA," *Cosmetics and Toiletries*, 109: No. 11, starting p. 55 (1994).
- 30 Levy, S. B., "Dihydroxyacetone-Containing Sunless or Self-tanning Lotions," *Journal of the American Academy of Dermatology*, 27: No.6, pp. 989-993 (1992).
- "Spray Application Processes," BINKS training brochure TD49-2R-4, August, 1995, BINKS Manufacturing Company, Franklin, Ill.

### BRIEF DESCRIPTION OF THE DRAWINGS

A more complete understanding of the invention may be had by reference to the following Detailed Description when taken in conjunction with accompanied Drawings, wherein:

FIG. 1 is a flow chart illustrating the invention;

FIG. 2 is a diagrammatic illustration of the system for automatically coating the human body of the present invention comprising the minimum requirements thereof;

FIG. 3 is an illustration similar to FIG. 2 wherein the system of the present invention is further provided with containment apparatus;

FIG. 4 is an illustration similar to FIG. 3 wherein the system of the present invention is further provided with an air ventilation apparatus;

FIG. 5 is an illustration similar to FIG. 4 wherein the system of the present invention is further provided with collection apparatus for residual spray;

FIG. 6 is an illustration similar to FIG. 5 wherein the system of the present invention is further provided with apparatus to effect rotation of the human body being coated;

FIG. 7 is an illustration similar to FIG. 6 wherein the system of the present invention is further provided with multiple discharge nozzles;

FIG. 8 is an illustration similar to FIG. 5 wherein the system of the present invention is adapted to the coating of a selected part of the human body;

FIG. 9 is a front view of an apparatus useful in the practice of the invention;

FIG. 10 is a top view of the apparatus of FIG. 9;



US 6,474,343 B2

5

FIG. 11 is an illustration of one of the spray columns of the apparatus of FIG. 9; and

FIG. 12 is an enlarged view illustrating the nozzle assemblies utilized in the spray columns of the apparatus of FIG. 9.

DETAILED DESCRIPTION OF THE INVENTION

Referring now to the Drawings, and particularly to FIG. 1, the system for automatically coating the human body of the present invention may comprise an automated coating system for numerous types of formulations, including but not limited to the application of:

- self-tanning formulations,
- sunscreens,
- suntan lotions,
- tanning accelerators,
- sunburn treatments,
- insect repellants,
- skin toners,
- skin bleaches,
- skin lighteners,
- anti-microbial compositions,
- moisturizers,
- exfoliants,
- nutriments or vitamins,
- massage aides,
- muscle relaxants,
- skin treatment agents,
- burn treatment agents,
- decontamination agents,
- cosmetics,
- wrinkle treatments or removers.

The first component of such a system is the chemical composition. The suitability of a composition for coating is strongly influenced by its viscosity, with the preferred viscosity being close to that of water (1 centipoise). Compositions with viscosities in the 1 to 10 centipoise range generally atomize well, and viscosities in the 10 to 100 range can be atomized, but the resulting spray is not as fine. Higher viscosities can be atomized, and will work, but the spray is not as fine. Most currently marketed compositions of the aforementioned applications can be made suitable for atomization either as is or with appropriate dilution.

By way of example, a more detailed description of functional compositions for use in practice of the invention will be based on artificial tanning compositions. Six such compositions are given in Compositions 1, 2, 3, 4, 5, and 6. Individuals skilled in this art can create other compositions.

Ingredient	%
<u>COMPOSITION 1</u>	
Dihydroxyacetone	3.0
Water	97.0
<u>COMPOSITION 2</u>	
Dihydroxyacetone	3.0
Denatured Ethanol	20.0
Water	77.0

6

-continued

Ingredient	%
<u>COMPOSITION 3</u>	
Dihydroxyacetone	12.0
Denature Ethanol	20.0
Water	68.0
<u>COMPOSITION 4</u>	
Dihydroxyacetone	10.0
Commercial Sunless-Tanning Lotion	15.0
Water	75.0
<u>COMPOSITION 5</u>	
Dihydroxyacetone	9.0
Commercial moisturizer	20.0
Citric acid	0.3
Commercial bath product	0.6
Bronzer	6.0
Water	64.1

By way of example, a suitable commercial moisturizer would include Vaseline Brand Intensive Care Aloe and Naturals lotion (Chesebrough-Ponds, Greenwich, Conn.), and a suitable commercial bath product would include Vaseline Brand Intensive Care Foaming Creme Bath (Chesebrough-Ponds, Greenwich, Conn.). The bronzer is a combination of FD&C dyes that yield a golden brown color.

Ingredient	%
<u>COMPOSITION 6</u>	
Bronzer	8.0
Commercial moisturizer	20.0
Commercial bath product	0.6
Ethoxydiglycol	2.0
Water	69.4

By way of example, a suitable commercial moisturizer would include Vaseline Brand Intensive Care Aloe and Naturals lotion (Chesebrough-Ponds, Greenwich, Conn.), and a suitable commercial bath product would include Vaseline Brand Intensive Care Foaming Creme Bath (Chesebrough-Ponds, Greenwich, Conn.). The bronzer is a combination of FD&C dyes that yield a golden brown color.

By way of example, suitable commercial preparations include Coppertone® Oil-Free Sunless Tanner (Schering-Plough, Memphis, Tenn.), Neutrogena® Glow Sunless Tanning Lotion for Face and Body (Neutrogena, Los Angeles, Calif.), and Kroger® Sunless Tanning Cream (Kroger, Cincinnati, Ohio).

Compositions 1, 2 and 3 are greatly simplified versions of the formulations now on the market or reported in the past. This simplification is possible due to the use of the present invention for applying compositions to skin. These simplified compositions have several advantages over more complex formulations, including:

- faster drying,
  - less potential inhibition of DHA efficacy,
  - less potential for irritation from chemical components (because there are fewer components),
  - less residue on the skin,
  - less expensive,
  - more environmentally friendly.
- Compositions 4 and 5 illustrate how a commercial formulation not particularly well suited for atomization can be

## US 6,474,343 B2

7

diluted, effectively atomized and uniformly coated on human skin. Similar dilutions of products representing the other aforementioned applications can be effectively atomized and coated on human skin.

There is no pH adjustment required for these compositions, although the pH can be adjusted to alter the hue of the resulting tan and to alter the dihydroxyacetone stability. The optimal tanning occurs with DHA at a pH of below 6.0, preferably with the solution at a pH of 3.0 to 4.0. Unbuffered DHA has a pH of about 5.5. The pH on the surface of human skin is also about 5.5. Nonetheless, these formulations can be used over a wide pH range, and buffers or pH adjusters can be added.

A preferred colorant is DHA. DHA is available from Rona (Hawthorne, N.Y.). It is effective, safe, and approved by the FDA for this application. The preferred DHA concentration is 0.5% to 20%, with a more preferred range of 3.0% to 15.0%, and a most preferred range of 5% to 12%.

Numerous other colorants can also be used. Those agents include, but are not limited to:

- crotonaldehyde
- pyruvaldehyde
- glycolaldehyde
- glutaraldehyde
- ortho-phthaldehyde
- sorbose
- fructose
- erythrose
- methylvinylketone
- food coloring

Various dyes and UV blocking agents can be covalently linked to the colorant or can be mixed into the composition with the colorant.

Bronzers can also be used in combination with or as an alternative to DHA. Bronzers which can be used include, but are not limited to, lawsone and juglone. Combinations of DHA and bronzers can also be used, and can be used to modify the resulting color (hue) and intensity of the tan. The preferred range for lawsone, juglone, and FD&C dyes is 0.5% to 10.0% with the more preferred range of 1.0% to 5.0%.

Composition 6 is an example of a formulation containing only bronzers (no DHA). The preferred range of FD&C dyes in commercially formulated liquid form (e.g., food coloring by Adams Extract Co., Austin, Tex.) is 1% to 50%, with a more preferred range of 4% to 12%. Ethoxydiglycol is added to enhance the penetration of the dyes into the skin, to reduce transfer to clothing, and to assist in the stabilization of the formulation. The preferred ethoxydiglycol range is 1% to 20%, with a more preferred range of 2% to 10%.

Alcohol can be added to the composition to accelerate the rate of drying. Denatured ethanol (USP grade, commodity chemical) works well in this capacity. The preferred range for alcohol concentration is from 1.0% to 50.0%, with a more preferred range from 10.0% to 30.0%, and a most preferred concentration of 20.0%.

Other potential additives include:

- moisturizers,
- preservatives,
- antimicrobials,
- thickeners,
- solvents,
- emulsifiers,
- fragrances,

8

- stabilizers,
- sunscreens,
- surfactants,
- pH adjusters,
- anti-caking agents,
- ingredients to alter the color reaction.

It typically requires about 100 ml of a 5.0% DHA composition to obtain a medium to dark tan over an entire adult body (about 2 square meters of skin). A single application of about 250 ml of a 9% dihydroxyacetone composition over an entire adult human body will result in a very dark tan. The exact amount of dihydroxyacetone required depends on the skin type and intensity of tan desired. The tan can last for about 2 to 7 days, but usually lasts for 3 to 4 days. Multiple applications will darken the tan.

The second component of the invention is the atomization of the composition. The required atomization can be obtained by a host of ways, most of which involve passing the composition through an orifice under pressure. Methods now used to atomize solutions include the use of the following systems:

- air atomization
  - siphon feed
  - gravity feed
  - pressure feed
    - internal atomization
    - external atomization
    - low pressure low volume
    - high volume low pressure
- airless atomization
  - pressurized through small orifices
  - air-assisted
  - air-assisted heated
- electrostatic
  - using charged particles
  - heated charged particles
  - high speed rotational atomizers
- ultrasonic

These forms of atomization are the basis for most methods of producing atomized sprays, including misting and nebulization.

Using a single airless sprayer with a tip orifice of 0.6 mm, with a circular spray pattern of 12 inches at 12 inches from the tip, and with a flow rate of approximately 400 ml/min. the entire body (excluding the bottom of the feet) of an average-sized person can be coated with solution in 5 to 15 seconds. In practice, the underside of the feet usually get slightly tanned also from exposure to small quantities of residual artificial tanning composition on the floor of application area. The use of a single airless sprayer to apply a composition to human skin is illustrated in FIG. 2. In this figure and subsequent figures, 11 designates the orifice for atomization of the composition, 12 designates the atomized spray, and 13 designates the subject being sprayed. In this configuration, an operator must direct the flow of the spray. The configuration illustrated in FIG. 2 would also work for any of the other atomization methods aforementioned, and for any of the applications aforementioned. The preferred atomization method is the pressure-free air-atomization system, with an internal or external atomization configuration.

For a person to be coated as illustrated in FIG. 2 with an artificial tanning composition (or any composition of the applications aforementioned), several precautions should be taken. First, the person should hold their breath during the application and during the time required for the spray to

## US 6,474,343 B2

9

clear. If this process is done in an open area, the coating should take about 5 to 15 seconds and the clearing of residues should take 1 to 10 seconds. Thus, the person would need to hold their breath for 6 to 25 seconds. Alternatively, they could wear a filter over their mouth, have a filter inside of their mouth, or use a breathing tube. They can also wear nose plugs or filters. Second, the eyes should be protected even though most of these formulations are not likely to injure the eye. The simplest and most effective protection is to keep the eyes closed. Goggles or patches also work well, although they leave uncoated areas that must be subsequently coated manually. Next, precautions need to be taken if one wants to avoid the exposure of scalp hair. Scalp hair can be protected with a shower cap or any other similar protective covering impervious to the coating compositions. Also, hair can be coated with a water insoluble material such as petroleum jelly. Similar protection can be used to protect hair on any other parts of the body. Next, if atomization is from a single source, it is recommended that the person being coated turn while being coated, or that the coating apparatus be moved around the person being coated, or there be a combination of these movements. Finally, care must be taken that the nozzle remain at least several inches from the person being coated to prevent any possible injection of composition into the person. Generally, spray injection occurs at pressures greater than 500 psi with the person actually contacting the atomization orifice. The pressures here are less than 80 psi, and more typically 10 to 40 psi, and the person being coated should be a foot or more from the orifice.

The issue of what to wear during coating is usually of great concern to the person being coated. In the case of coating with artificial tanning solution, the selection of what to wear is a matter of preference for the person being coated. The subject can be coated nude, with underwear, with a bikini or a bathing suit, or with some form of pasties covering their private parts.

The third component of the invention is containment of the spray. Containment is illustrated in FIG. 3. In this figure and subsequent figures, 14 and 15 designate side panels and 16 and 17 designate the top and bottom panels, respectively. This type of containment is similar to the containment of spray paint using paint booths in automobile refinishing. Alternatively, spray containment can be obtained using electrostatic forces, where the atomized spray is charged and the residual charged spray is removed by activating charged collection plates. Of course, precautions must be taken so that the person being sprayed and the operator are isolated from the charged plates.

Containment of the spray is very important for several reasons. These reasons include but are not limited to:

- reducing waste,
- avoiding spray getting onto and staining items in the immediate surroundings,
- facilitating capture and recovery processes,
- better control of air flow,
- better control of temperature and humidity.

This type of containment facilitates the use of this invention in enclosed areas such as stores or medical facilities.

Control of air and spray flow is very important to the quality of the skin coating. It is highly preferable to have an exhaust fan drawing the spray towards the person being coated, and the residual composition out of the booth. In FIG. 4 is shown the addition of an exhaust fan 18. The fan offers several significant advantages to the invention. These advantages include but are not limited to:

10

- better control of air flow
- shorter exposure to residue spray, requiring less time to hold breath or breathe through filter or air line
- faster drying of the coated composition on skin
- better quality coating

The fan 18 should have a flow of 10 to 5000 cubic feet per minute per square foot of opening, preferably 50 to 1000 cubic feet per minute per square foot, and most preferably 100 to 400 cubic feet per minute per square foot. At flow rates of below 100 cubic feet per minute per square foot, the air movement is sufficient to guide the atomized spray through the containment area. At flow rates of 100 to 400 cubic feet per minute per square foot, the atomized spray is being actively drawn through the containment area and the application and drying process is enhanced. At rates above 400 cubic feet per minute per square foot, the atomized spray is being accelerated and the exhaust flow plays a much more prominent role in the application process. The flow rate of the air through the containment area is therefore a major parameter which can be varied to modify the characteristics of the coating of the artificial tanning composition to the skin. The drying time for the composition deposited on skin is also effected by flow rate, with drying time decreasing as flow rates increase. At rates above 100 cubic feet per minute per square foot, the drying time (to the point of no transfer to other surfaces upon contact) is less than 5 minutes.

At any flow rate above 10 cubic feet per minute per square foot, the residual atomized spray is completely removed from the containment area within one second. This rapid removal is important to minimize the time the person being tanned is exposed to spray and has the potential to inhale this spray. In the absence of this air flow, the residual spray lingers in the area for several minutes, and traces can be detected hours later. This vigorous flow also protects any individuals or operators near the atomizing orifices from back spray.

The final element of this invention is recovery, or filtering, of residual composition. This feature greatly enhances the utility of the invention because it allows the system to be self-contained in an indoor environment and promotes a more environmentally friendly process. Without a recovery system, there is a potential for the exhausted residue to stain anything it contacts. Also, there could be an accumulation of residue with time. One configuration of the recovery system is shown in FIG. 5. In this figure and subsequent figures, the recovery system or filter is denoted as 19. Recovery of both particulates and solvents is possible. Potential filters include a high-efficiency filter such as Binks' (Franklin Park, Ill.) Paint Pockets or Columbus Industries' (Ashville, Ohio) High-Capacity Supra Mini-Mesh, a form of a carbon filter, a water-wash filter, or an exchange-type resin. The efficiency of particulate and solvent removal should be greater than 99%. As an alternative to high-efficiency filtering, the spray residuals could be vented to the outside environment.

Additional features adding to the utility of the invention are shown in FIG. 6 and FIG. 7. In FIG. 6 there is shown the addition of a motorized turntable 20. This turntable 20 will rotate the person being coated, eliminating rotation by the individual as a possible source of error or problems. It also is a major convenience for the person being coated. The preferred rate of rotation is in the range of 1 to 60 rpm, with a more preferred range of 5 to 20 rpm, with a most preferred rate of rotation of 12 rpm.

In FIG. 7 there is shown the use of multiple atomizing orifices. The use of multiple orifices facilitates the automation of this process, and reduces operator effort and potential

## US 6,474,343 B2

11

error. It also reduces the time required to fully coat an individual. The typical round spray pattern is about 12 inches wide at 8 to 12 inches from the orifices, so a preferred spacing of multiple orifices will be 8 to 12 inches apart, but could be positioned from 1 to 48 inches apart. Fan patterns from wide-angle nozzles at 18 inches are typically 24 inches long and 9 inches wide. Using the preferred configuration, an individual can be coated in 5 seconds or less. In FIG. 7, the orifices are aligned in a vertical pattern. The coverage of more area at one time could also be obtained by rapidly moving one or more orifices along a track or by rapidly altering the angle of the orifice. Other patterns are possible, including combinations of vertical and horizontally aligned orifices. Orifices could also be aligned radially, with the subject being sprayed with orifices aligned from 0 to 360°. Another alignment is a horizontal ring containing orifices that surround the body. By vertically raising and lowering the horizontal ring, the entire body or selected parts of the body could be coated.

In an open environment, such as a beach or a park, a modified version of configuration illustrated in FIG. 7 could be used to rapidly coat an individual. It would even be possible to have a walk-through coating system. An atomized spray could be produced from multiple nozzles arranged in a single line (as shown in FIG. 7), in two single lines facing one another and about 36 to about 48 inches apart, or multiple lines of nozzles. The preferred configuration is multiple lines, with 4 lines being adequate. The atomized spray results in an area of intense atomized solution, which would coat an individual standing in that area. The residual spray would then be dissipated into the surrounding environment. A fan could be used to accelerate the removal of the residuals from the coating area.

FIG. 8 illustrates how the system of the present invention can be used to tan a selected part of the body. In this case, just the face is being tanned. In this figure the bottom panel of the apparatus 22 contains an opening through which one can insert his or her head. The top panel 23 is arched. The high-efficiency filter is 19. The fan and back panel is 18. Alternately, the setup as shown in FIGS. 2-7 could be used to tan only a select part of the body by protecting the area not desired to be tanned with appropriate barrier apparel or by screens between the atomized spray and the regions of the skin not to be coated. The barrier apparel could be any material impervious to the atomized coating composition. For example, materials appropriate for use with the aforementioned coating compositions include vinyl, polyurethane, and latex rubber. The screens can be sheets composed of any material impervious to the atomized artificial tanning compositions, including most metals or plastics. A preferred screening material is foam with an impervious aluminum foil backing. The foam is aligned with the backing away from the atomizing orifice. The foam is preferred because it absorbs much of the atomized spray, reducing back deflection.

FIGS. 9, 10, 11, and 12 illustrate an apparatus which may be utilized in the practice of the invention. The apparatus 30 comprises a unitary construction which includes both a coating chamber 32 adapted to receive a person to be coated with a predetermined substance and various components utilized to effect spraying of the predetermined substance onto the person situated within the coating chamber 32.

The coating chamber 32 includes a door 34 which affords ingress to and egress from the coating chamber. The coating chamber 32 is further provided with a plurality of spray columns 36. As is best shown in FIG. 10, the spray columns 36 are located at spaced apart points around the periphery of

12

the chamber 32. Those skilled in the art will appreciate the fact that neither the number nor the precise location of the spray columns 36 is critical to the practice of the invention, and that other spray column arrangements may be utilized in the practice of the invention, if desired.

The spray columns 36 are preferably supported for pivotal movement through predetermined arcs under the action of a pneumatic cylinder 38. In this manner the predetermined material is discharged from the spray columns 36 in such a way as to assure uniform coating of the predetermined material on a person situated within the spray chamber 32. The pneumatic cylinder 38 is connected to the pivoting mechanism of each of the spray columns 36 through a plurality of links 40.

Referring again to FIG. 9, there is further included a blower 46 which directs a flow of air upwardly along an air guide 48 and then laterally along a top panel 50 into engagement with a plurality of baffles 52. The baffles 52 direct the air from the blower 46 downwardly through the coating chamber 32, whereby the flowing air effects drying of the sprayed material and aids in recovery of the sprayed material for reuse. From the coating chamber 32 the air is directed through a plurality of filters 54 and is returned to the blower 46.

The predetermined material which is to be coated onto a person situated within the coating chamber 32 is preferably provided in the form of a liquid which is received in a reservoir 60. The interior of the reservoir 60 is pressurized by compressed air which is received from an air compressor 62 through an air tank 64. Compressed air from the air compressor 62 in the tank 64 is also directed to an air tank 66 and to a manifold 68. The air tank 66 provides compressed air for operating the pneumatic cylinder (FIG. 10). The manifold 68 directs compressed air to the spray columns 36.

Ideally, all of the liquid from the reservoir 60 which is discharged from the spray columns 36 would be received on the body of the person within the coating chamber 32. In actual practice, it is not possible to obtain 100% efficiency in the coating procedure. Excess liquid which is discharged from the spray columns moves downwardly under the action of gravity onto a drain ramp 72. A drain pump 74 receives the excess liquid through a suction pipe 76 and delivers it to an appropriate drain.

Referring to FIGS. 11 and 12, each spray column 36 includes an inner tubular passageway 84 which receives liquid from the reservoir 60 under the action of compressed air supplied by the air compressor 62 through the tank 64 and an outer tubular passageway 86 which receives compressed air from the manifold 68. Each spray column 36 is provided with a plurality of nozzles 88. Each nozzle 88 receives compressed air from the outer tubular passageway 86 through a quick disconnect 90 and receives liquid from the inner tubular passageway 84 through a quick disconnect 92. A check valve 94 prevents reverse flow of liquid back through the quick disconnect 92.

Features Contributing Significantly to the  
Successful Operation of an Automated Coating  
System for the Human Body Incorporating the  
Invention

Preferred Formula

The preferred formula is a combination of water, dihydroxyacetone, bronzer, moisturizer, surfactant, and penetration enhancer. The formula is:

US 6,474,343 B2

water	base	62.6%	36%–85.9%
dihydroxyacetone bronzer*	self-tanning cosmetic colorant	9.0% 5.0%	3%–15% 0%–10%
ethoxy diglycol commercial moisturizer lotion**	penetration enhancer film former, viscosity	4.0%	0%–10% 18.0%
commercial bath product***	surfactant	1.2%	0%–2%
citric acid	pH adjustment	0.2%	0.1% to 1.0%

\*By way of example, a suitable bronzer would be a combination of the following food dyes provided by Adams Extract Company, Austin, Texas: 4 parts red, 2 parts yellow, 1 part green, and 3 parts purple.  
 \*\*By way of example, a suitable commercial moisturizer lotion includes Vaseline Intensive Care Lotion (Aloe Vera Triple Action Formula, Chesebrough-Ponds, Greenwich, CT).  
 \*\*\*By way of example, a suitable commercial bath product includes Vaseline Intensive Care Foaming Creme Bath (Chesebrough-Ponds, Greenwich, CT).

Foot Shields

The feet are one of the most difficult parts of the body to coat uniformly. This difficulty is due in large part to the irregular structure of feet. Also, the downward motion of the atomized mist, both by gravity and from air currents, tends to cause the mist to settle on the tops of the feet. Therefore, the feet are provided with shields to assure a more uniform coating of the feet. The shields may take the form of a large, bottomless shoe. The shields produce a silhouette effect from the top of the feet to the toes. Holes and openings are provided in the shields which are located 0.25 to 2 inches from the feet, allowing the mist to result in a silhouette effect rather than defined lines.

Air Shield to Deflect Air Away from the Feet

To reduce the amount of mist settling on the feet, a plastic shield shaped like a FIG. 8 is placed between the fleximat flooring the user stands on and the metal grating supporting the fleximat. Dimensions of the figure eight are two 18 inch diameter overlapping circles with a total width of 26 inches. The total width can vary from 18 inches to 36 inches, and the circle diameters can vary from 12 inches to 20 inches.

Towelng Buffng After Coating

After coating it is advantageous to use a towel rub to buff over the entire body to yield a more uniform coating and to remove any areas of excess. The towelng yields a more cosmetically pleasing result and reduces transfer to clothing. It is preferred to towel using long, light strokes. A cotton bath towel 16 inches by 32 inches may be used. The towel could vary from a hand cloth (8"x8") to a large beach towel (18"x48"). Care must be taken not to rub so hard or too much as to rub off the coating (or tan). Basically, the weight of the preferred towel is adequate, without additional pressure.

Stance During Coating

The stance used during the coating is important. After trial and evaluation of numerous methods, it has been discovered that the "ballerina stance" seems to work best. Key elements of the stance are:

- hands over the head
  - preferred 2 inches
  - lower limit—hands touching head
  - upper limit—arms extended fully up
- hands parallel to the floor
  - hands could be, but not recommended to be, perpendicular to
  - floor in a praying stance, or facing downwardly
- feet separated about 12 inches
  - to allow mist to coat inside of legs
  - feet are flat on flooring
  - use of feet shields as described above

Hair Net

Although the above-described self-tanning solution does not turn hair orange, it may accumulate on hair. To avoid this accumulation, the user can wear a hair net or bouffant.

5 Preferred compositions for the hair net include a cloth or plastic mesh or a continuous plastic sheet.  
 Barrier Cream

It has been discovered that the commercial barrier cream produced by GoJo blocks the tanning solution from the skin. During the coating process, this lotion can be used to prevent tanning, of specific areas, such as the palms of the hands.  
 High Efficiency Filter

10 The use of high efficiency filters to remove excess mist is important. Preferably, a Binks high-efficiency paint-pockets filter is used.

Recharging of Filter

15 It has been discovered that the tanning solution trapped in the filter can be removed with a water rinse. The solution, which is water soluble, is flushed out using water that is back-washed (water applied to the top surface opposite of the surface facing the solution) or water, preferably under moderate (greater than 60 psi) pressure, that is hoses on the filtered surface.

Uniform Air Flow

20 Uniformity of air flow is very important to assure that the mist continues to be applied uniformly over the body even after the pressurized spray stops. Air flow parameters are, in the downward motion:

most preferred	100 cfm
next preferred	50 cfm to 200 cfm
next preferred	25 cfm to 300 cfm

Warming of Air

25 Atomization of liquids as done here by the nozzles results in a significant reduction in liquid temperature (as much as 20° F.). To keep the temperature to a warm, pleasant experience, four halogen lamps (250 watts each) can be added to the system to provide both illumination and heat. A coating chamber temperature of 80° F. to 110° F. is preferred, with 90° F. to 100° F. being more preferred. Other heating devices include infrared lamps and electrical heating elements.

EXAMPLES

Example 1

30 A twenty year old female of type III skin tanned by this process. She first applied a heart shaped sticker on her right arm. She covered her hair with a nylon mesh hair net and applied barrier cream over the palms of her hands. She tanned in the coating chamber. The formula above was coated for 7 seconds. About 300 grams of solution was applied during such time. There was a subsequent 7 second period in which the mist was circulated in the booth. The residual mist was removed from the booth and the subject dried for about 45 seconds. The subject then removed any excess lotion with a towel. The final result was that the subject was 1 to 2 shades darker after tanning. This difference was especially apparent when comparing the area under the sticker with the area with no sticker. The initial color was mainly from the bronzer, and is a deep brown color. Color was much more intense the next day, when the color was at least two shades darker than before tanning.

## US 6,474,343 B2

15

After the subject showered, the intensity was dropped to about 1 shade darker than prior to tanning. This color, which was mainly from the dihydroxyacetone, was golden-brown. The color persisted about 1 shade darker for 3-4 days, and noticeable color was present for 7 days.

## Example 2

A forty seven year old male with type II skin tanned by this process. He first applied a heart shaped sticker on his right arm. He covered his hair with a nylon mesh hair net and applied barrier cream over the palms of his hands and the bottoms of his feet. He tanned in the coating chamber. The formula above was coated for 7 seconds. About 300 grams of solution was applied during time. There was a subsequent 7 second period in which the mist was circulated in the booth. The residual mist was removed from the booth and the subject dried for about 45 seconds. The subject then removed any excess lotion with a towel. The final result was that the subject was about 1 shade darker after tanning. This difference was especially apparent when comparing the area under the sticker with the area with no sticker. The initial color was mainly from the bronzer, and is a deep brown color. Color was much more intense the next day, when the color was one to two shades darker than before tanning. After the subject showered, the intensity was dropped to about 1 shade darker than prior to tanning. This color, which was mainly from the dihydroxyacetone, was golden-brown. The subject repeated the tanning process again later the second day. This time, the initial tan from the combination of previous tan and new bronzer was about 2 shades darker than before. Even after showering the next day, the tan was about two shades darker than prior to initially tanning. The color persisted about 2 shades darker for 3-4 days, and noticeable color was present for 10 days.

## Example 3

A 24 year old female with type II skin tanned as described in examples 1 and 2 for five consecutive days. The results were a highly uniform, very dark tan. Her skin color was about 3 shades darker by the end of the week. The color was golden brown. The color remained 2 to 3 shades darker for about 4 days, and some color (about 1 shade) was observed after 7 days.

## Discoveries

**Hair is not Turned Orange**

Self-tanning lotions have been reported to turn body hair orange. The formulation and application of the present invention do not cause the hair to turn orange. First, the formulation does not penetrate the hair, but rather beads up on it. Next, it is applied in a very thin coat. The net result is that the hair does not turn orange.

**Produces a Very Uniform Tan**

The present invention facilitates the application of a thin, uniform film over the entire body. Consequently, the resulting coating and tan is far superior to manual application methods.

**Bronzer Tends to Last Longer than Expected**

The bronzer provides immediate color and a method for observing the uniformity of the tan. The uniformity of the bronzer application is greatly enhanced because it is applied in a uniform thin film and its substantivity is enhanced because of deeper penetration into skin with the presence of a penetration enhancer.

**Use of Ethoxy Diglycol as a Penetration Enhancer Makes the Tan Last Longer and More Uniform**

With the use of ethoxy diglycol, the duration of uniform intense tan has increased from an average of about 2 days to an average of about 4 days, and some color persists for up to 14 days.

16

Although preferred embodiments of the invention are illustrated in the Drawings and described in the Detailed Description, it will be understood that the invention is not limited to the embodiments disclosed, but is capable of numerous modifications and rearrangements of parts and elements without departing from the spirit of the invention.

What is claimed is:

1. An apparatus for coating substantially the entire human body with a human skin coating material comprising:

structure defining a coating chamber for receiving the entire body of a person to be coated;

a reservoir for receiving the human skin coating material in liquid form;

at least one nozzle positioned within the coating chamber for receiving the human skin coating from the reservoir and for discharging a spray comprising the human skin coating liquid onto the skin comprising substantially the entire body of the person in the coating chamber;

apparatus for moving the spray discharge of the nozzle relative to the body of the person to be coated thereby assuring a uniform coating of the human skin coating material over substantially the entire body of the person;

the structure defining the coating chamber further comprising apparatus for receiving at least part of the spray from the nozzle which is not received on the skin of the person;

apparatus for circulating air independently of the liquid discharged from the nozzle and around the body of the person to be coated and thereby removing from the coating chamber the remainder of the spray from the nozzle which is not received on the skin of the person; and

apparatus for disposing of the spray which is not received on the skin of the person.

2. The apparatus for coating substantially the entire human body with a human skin material according to claim 1 further comprising:

at least one filter for removing excess spray from the circulating air.

3. An apparatus for coating substantially the entire body of a person with a human skin coating material in liquid form comprising:

an enclosure defining a coating chamber for receiving the entire body of the person to be coated;

a reservoir for receiving the human skin coating liquid;

at least one nozzle positioned within the coating chamber for receiving the human skin coating liquid from the container and for discharging the liquid onto the skin of the person within the coating chamber;

apparatus for causing the predetermined human skin coating liquid to flow from the reservoir through the nozzle for discharge in the form of a spray;

apparatus for moving the spray from the nozzle relative to the body of the person to be coated and thereby assuring a uniform coating of the human skin coating material over substantially the entire body of the person;

the structure defining the coating chamber further comprising apparatus for receiving excess spray from the nozzle which is not received on the skin of the person;

apparatus for disposing of the excess spray; and

apparatus for circulating air through the coating chamber independently of the discharge of liquid from the

US 6,474,343 B2

17

nozzle and around the body of the person therein during the discharge of the human skin coating liquid from the nozzle.

4. A method for coating substantially the entire body of a person with a human skin self tanning material comprising the steps of:

- 5 providing a coating chamber for receiving the entire body of a person to be coated;
- 10 providing a reservoir for receiving the human skin self tanning material in liquid form;
- 15 providing at least one nozzle positioned within the coating chamber;
- 20 discharging the human skin self tanning liquid from the reservoir through the nozzle and thereby discharging the human skin self tanning liquid onto the skin comprising substantially the entire body of the person in the coating chamber;
- 25 moving the nozzle discharge relative to the body of the person to be coated and thereby assuring a uniform coating of the human skin self tanning material over substantially the entire body of the person;
- 30 receiving at least part of the discharge from the nozzle which is not received on the skin of the person;
- circulating air independently of the discharge from the nozzle and around the body of the person to be coated and thereby removing from the coating chamber the remainder of the discharge from the nozzle which is not received on the skin of the person; and
- disposing of the nozzle discharge which is not received on the skin of the person.

18

5. The method for coating substantially the entire human body with a human skin self tanning material according to claim 4 further comprising:

providing at least one filter for removing excess nozzle discharge from the circulating air.

6. A method for coating substantially the entire body of a person with a human skin self tanning material comprising the steps of:

- 10 providing an enclosure defining a coating chamber for receiving the entire body of a person to be coated;
- 15 providing a reservoir for receiving the human skin self tanning liquid;
- 20 providing at least one nozzle positioned within the coating chamber for receiving the human skin self tanning liquid from the reservoir and for discharging the liquid onto the person within the coating chamber;
- 25 moving the nozzle spray discharge relative to the body of the person to be coated and thereby assuring a uniform coating of the human skin self tanning material over substantially the entire body of the person;
- 30 receiving the excess spray from the nozzle which is not received on the skin of the person;
- disposing of the excess spray; and
- circulating air through the coating chamber independently of the discharge of liquid from the nozzle and around the body of the person therein during the discharge of the human skin self tanning liquid from the nozzle.

\* \* \* \* \*

**UNITED STATES PATENT AND TRADEMARK OFFICE  
CERTIFICATE OF CORRECTION**

PATENT NO. : 6,474,343 B2  
DATED : November 5, 2002  
INVENTOR(S) : Laughlin et al.

Page 1 of 1

It is certified that error appears in the above-identified patent and that said Letters Patent is hereby corrected as shown below:

Column 1,

Line 53, replace "comeum" with -- corneum --.

Column 4,

Line 17, replace "pp.349-351" with --pp. 349-351 --.

Line 32, replace "No.6, pp." with -- No. 6, pp. --.

Column 5,

Line 45, replace "Generally" with -- generally --.

Column 7,

Line 18, replace "of5%" with -- of 5% --.

Line 66, replace "emulsifiers,." with -- emulsifiers, --.

Column 13,

Line 33, replace "FIG. 8" with -- figure eight --.

Column 14,

Line 11, replace "tanning, of" with -- tanning of --.

Signed and Sealed this

Fourth Day of March, 2003



JAMES E. ROGAN  
*Director of the United States Patent and Trademark Office*