

1

RIKER, DANZIG, SCHERER, HYLAND & PERRETTI LLP
Headquarters Plaza
One Speedwell Avenue
Morristown, New Jersey 07962-1981
(973) 538-0800

MORGAN, LEWIS & BOCKIUS LLP
101 Park Avenue
New York, New York 10178
(212) 309-6000

RECEIVED
JUN 17 2003
6:08 P.M.
AT 8:30
WILLIAM T. WALSH
CLERK

Filed

Federal Bar No. EFC-6575

Attorneys for Plaintiff
Metrologic Instruments, Inc.

6-17-03
AT 8:30
WILLIAM T. WALSH
CLERK

METROLOGIC INSTRUMENTS, INC.

Plaintiff,
v.

SYMBOL TECHNOLOGIES, INC.

Defendant.

UNITED STATES DISTRICT COURT
DISTRICT OF NEW JERSEY

Civil Action

Civil Action No. 03cv2912 (HAA)

COMPLAINT FOR PATENT
INFRINGEMENT

JURY TRIAL DEMANDED

Plaintiff Metrologic Instruments, Inc. ("Metrologic"), by its attorneys, Riker, Danzig, Scherer, Hyland & Perretti and Morgan, Lewis & Bockius LLP, as and for its Complaint against defendant Symbol Technologies, Inc. ("Symbol"), avers and alleges as follows:

THE PARTIES

1. Plaintiff Metrologic is a New Jersey corporation having its principal place of business at 90 Colcs Road, Blackwood, New Jersey.

2. Defendant Symbol is a Delaware corporation having its principal place of business at One Symbol Plaza, Holtsville, New York.

3. Metrologic and Symbol are signatories to a patent cross-license agreement ("the Agreement") that has been in effect since January 1, 1996 and are competitors in the bar code scanning equipment business.

JURISDICTION AND VENUE

4. This is a civil action for patent infringement arising under Title 35 of the United States Code as hereinafter more fully appears. This is also a declaratory action for breach of the above-referenced Agreement arising under 28 U.S.C. § 2201 *et seq.*

5. This Court has subject matter jurisdiction over the present action, pursuant to 28 U.S.C. §§ 1331, 1332 and 1338(a).

6. This Court has subject matter jurisdiction pursuant to 28 U.S.C. § 1332, in that Metrologic and Symbol are citizens of different states and the amount in controversy herein exceeds seventy-five thousand dollars (\$75,000.00), exclusive of interest, attorneys fees and costs.

7. Venue is proper in this judicial district pursuant to 28 U.S.C. §§ 1391(b) and 1400(b).

8. Upon information and belief, Symbol is registered to do business within the State of New Jersey and maintains a registered agent in New Jersey to receive service of process on its behalf.

9. Upon information and belief, Symbol has a business office at 401 Hackensack Avenue, Hackensack, New Jersey.

10. Upon information and belief, Symbol's sales force and distributors conduct systematic and continuous business activities in New Jersey.

SYMBOL'S BUSINESS

11. Symbol manufactures and distributes a variety of laser-based bar code scanning products, including but not limited to, the following two products: M2000 and LS1900 bar code scanners.

12. Upon information and belief, Symbol has committed acts of infringement in this judicial district by selling or offering to sell the M2000 and LS1900 products, either directly or through intermediaries, for use in the State of New Jersey.

**FIRST CAUSE OF ACTION FOR PATENT INFRINGEMENT
PURSUANT TO 35 U.S.C. § 271 et seq.**

13. On August 23, 1994, United States Patent No. 5,340,971 (the "'971 patent"), entitled "Automatic Bar Code Reading System Having Selectable Long Range and Short Range Modes of Operation," was duly and legally issued to George Rockstein, *et al.* Since that date, Metrologic has been and still is the owner of the '971 patent. Attached hereto as Exhibit A is a true and correct copy of the '971 patent.

14. On July 20, 1999, United States Patent No. 5,925,870 (the "'870 patent"), entitled "Automatic Hand-Supportable Laser Bar Code Symbol Scanning Device and Method of Scanning Bar Codes Using Same," was duly and legally issued to David Wilz, *et al.* Since that date, Metrologic has been and still is the owner of the '870 patent. Attached hereto as Exhibit B is a true and correct copy of the '870 patent.

15. On August 17, 1999, United States Patent No. 5,939,698 (the "'698 patent"), entitled "Bar Code Symbol Reading System Having Automatic Hand-Supportable Bar Coding

Symbol Reading Device and Stand for Supporting Projected Scan Field Thercof," was duly and legally issued to George B. Rockstein, *et al.* Since that date, Metrologic has been and still is the owner of the '698 patent. Attached hereto as Exhibit C is a true and correct copy of the '698 patent.

16. On December 5, 2001, Metrologic identified to Symbol, *inter alia*, two Symbol scanner products, Model Nos. M2000 and LS1900 that infringe Metrologic patents not licensed to Symbol under the Agreement.

17. On February 21, 2002, Metrologic notified Symbol that the '971, '870 and '698 patents were infringed by Symbol's M2000 and LS1900 scanner products. Metrologic indicated to Symbol that it would need to elect, pursuant to Section 4.3 of the Agreement, a fourth, fifth and sixth Licensable Metrologic Patent Family in order to obtain a license for these scanner products.

18. On May 24, 2002, Symbol elected fourth, fifth and sixth Licensable Metrologic Patent Families pursuant to Section 4.3 of the Agreement.

19. Since making the May 24, 2002 election, Symbol has made no royalty payments for the M2000 and LS1900 scanner products sold under the fourth, fifth and sixth Metrologic Patent Families.

20. On October 2, 2002, Metrologic notified Symbol that quarterly royalties were due and owing for the fourth, fifth, and sixth elected Metrologic Patent Families as a result of Symbol's sales of the M2000 and LS1900 scanner products.

21. Despite having elected the required Metrologic Patent Families and owing royalties thereunder, Symbol has contended that the M2000 and LS1900 scanner products do not infringe any Metrologic patents.

22. Symbol has for a time past been and still is infringing claims 44-48, 50 and 51 of the '971 patent by making, selling, and using M2000 bar code scanners embodying the patented invention.

23. Symbol has for a time past been and still is infringing claims 1-3, 7, 8, 10, 13 and 14 of the '870 patent by making, selling, and using LS 1900 bar code scanners embodying the patented invention.

24. Symbol has for a time past been and still is infringing claims 1-3, 7 and 9 of the '698 patent by making, selling, and using LS 1900 bar code scanners embodying the patented invention.

25. Upon information and belief, Symbol's infringement has been willful and deliberate and will continue unless enjoined by this Court.

SECOND CAUSE OF ACTION FOR BREACH OF CONTRACT

26. Metrologic repeats and realleges each of the allegations of paragraphs 1 through 25 hercof as if fully set forth herein.

27. Symbol's election of the fourth, fifth and sixth Metrologic Patent Families obligated Symbol to make quarterly royalty payments for the M2000 and LS1900 scanner products because these products are included within one or more of the elected Metrologic Patent Families under the Agreement.

28. On September 10, 2002, Metrologic requested that Symbol make its required quarterly royalty payment for the M2000 and LS1900 scanners.

29. On September 13, 2002, Symbol provided a royalty report to Metrologic and indicated that no royalties with respect to the fourth, fifth and sixth elected Metrologic Patent Families were due and owing to Metrologic.

30. On October 2, 2002, Metrologic demanded payment and noted that non-payment of royalties was a material breach of the Agreement. Symbol did not respond to Metrologic's demand for payment.

31. Symbol's failure to make royalty payments for the M2000 and LS1900 scanners constitutes a material breach of the Agreement.

WHEREFORE, plaintiff Metrologic prays for judgment:

- a. Finding that defendant Symbol has infringed and continues to infringe the claims of United States Patent No. 5,340,971;
- b. Finding that defendant Symbol has infringed and continues to infringe the claims of United States Patent No. 5,925,870;
- c. Finding that defendant Symbol has infringed and continues to infringe the claims of United States Patent No. 5,939,698;
- d. Finding that defendant Symbol has materially breached the Agreement;
- e. Finding that such rights and licenses as Symbol might otherwise enjoy under the Agreement are terminated due to its material breach;
- f. Awarding plaintiff its damages for Symbol's breach of the Agreement;
- g. Awarding plaintiff its damages, including enhanced damages for willful infringement;
- h. Awarding plaintiff preliminary and final injunctions enjoining defendant Symbol and its officers, agents, servants, employees and privies from infringement of the '971, '870 and '698 patents; and

i. Awarding plaintiff its costs, expenses, and reasonable attorneys fees and such other and further relief as this Court may deem just and proper.

RIKER, DANZIG, SCHERER, HYLAND &
PERRETTI LLP
Attorneys for Plaintiff
Metrologic Instruments, Inc.

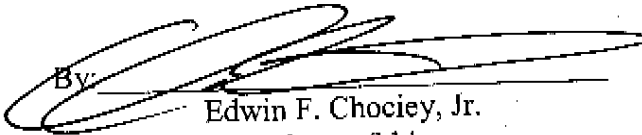
By: 
Edwin F. Chociey, Jr.
Eric Blumenfeld

Dated: June 17, 2003

Of Counsel:

Dennis J. Mondolino, Esq.
Michael F. Hurley, Esq.
MORGAN, LEWIS & BOCKJUS LLP
101 Park Avenue
New York, New York 10178
(212) 309-6000

JURY DEMAND

Plaintiff Metrologic Instruments, Inc. hereby demands trial by jury of all issues in this case.

LOCAL CIVIL RULE 11.2 CERTIFICATION

I certify that to the best of my present knowledge the matter in controversy is not the subject of any other action pending in any court, or of any pending arbitration or administrative proceeding.

Eric Blumenfeld

Dated: June 17, 2003

3314077.02

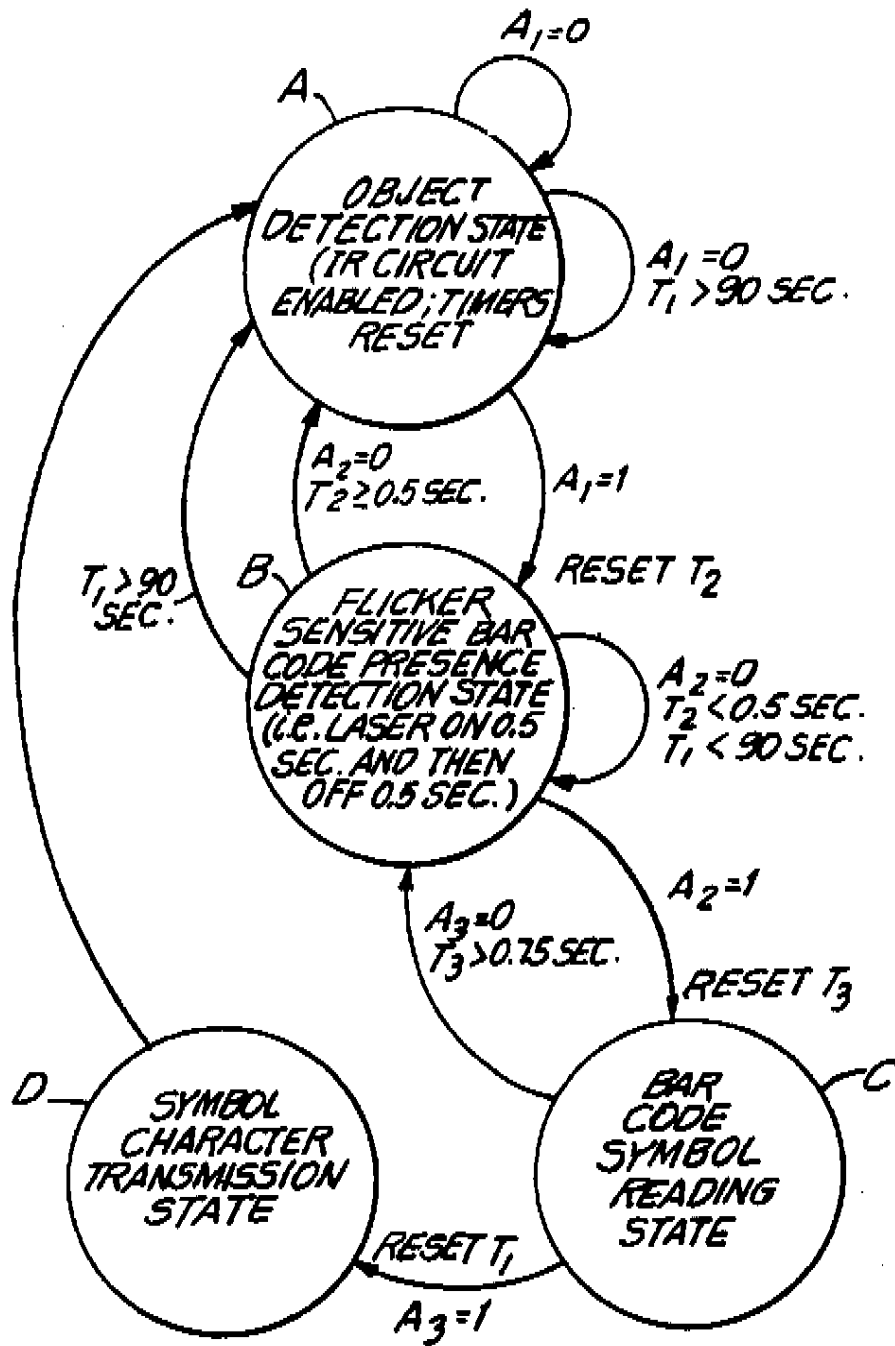

FIG. 9

U.S. Patent

Jul. 20, 1999

Sheet 14 of 19

5,925,870

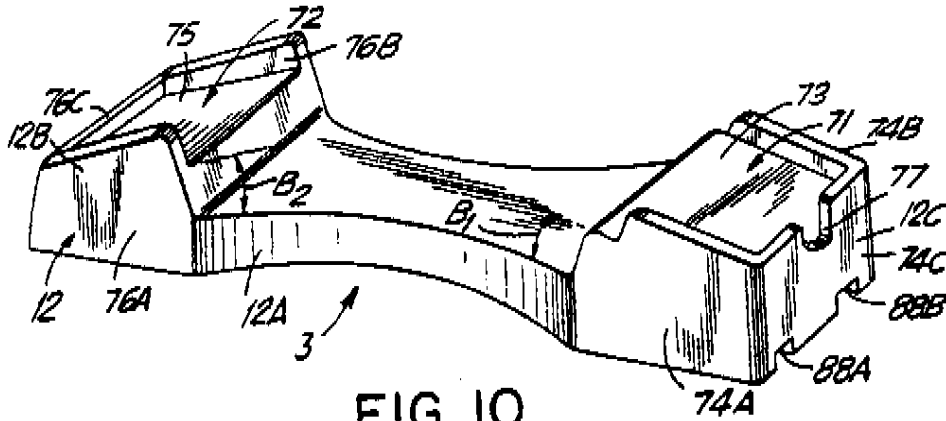

FIG. 10

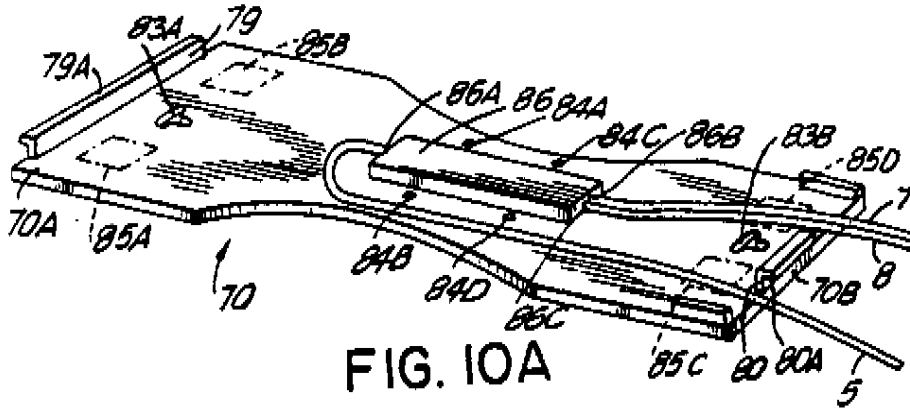

FIG. 10A

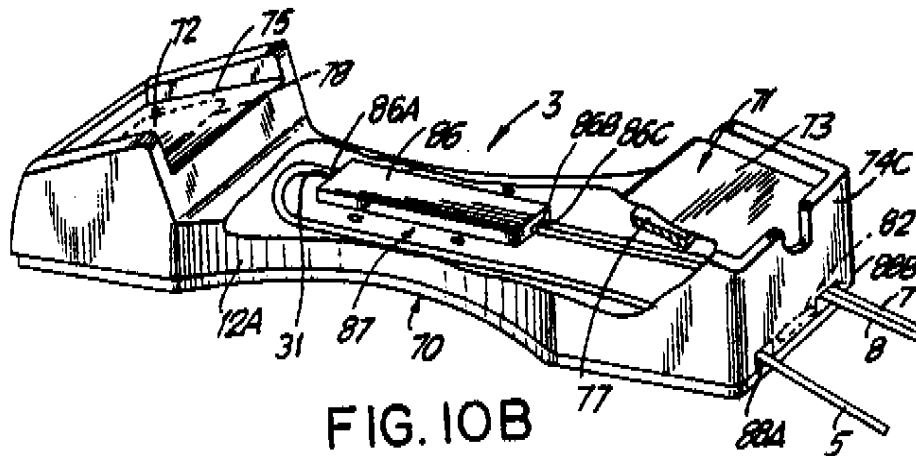

FIG. 10B

U.S. Patent

Jul. 20, 1999

Sheet 15 of 19

5,925,870

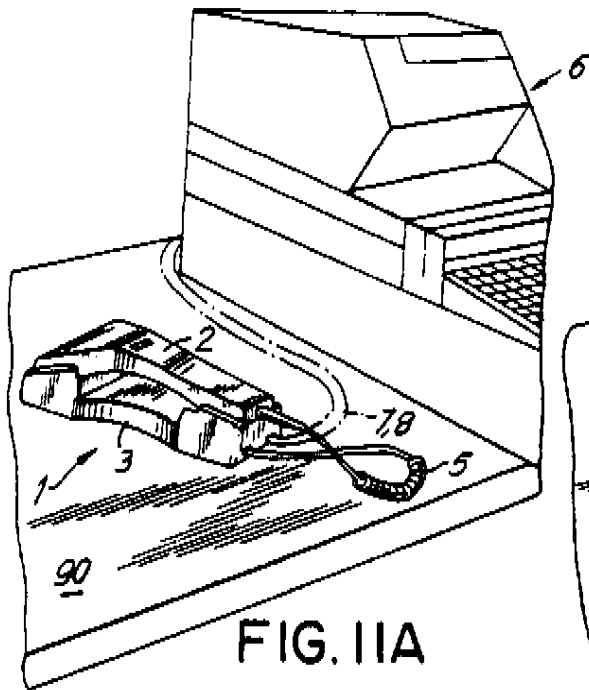

FIG. IIA

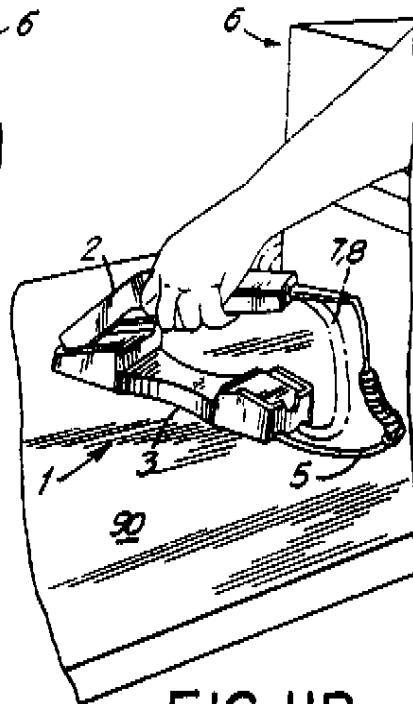

FIG. IIB

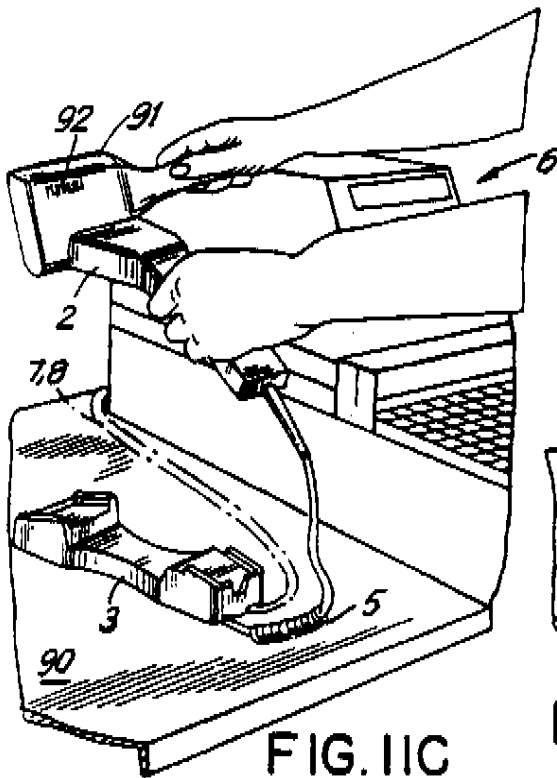

FIG. IIC

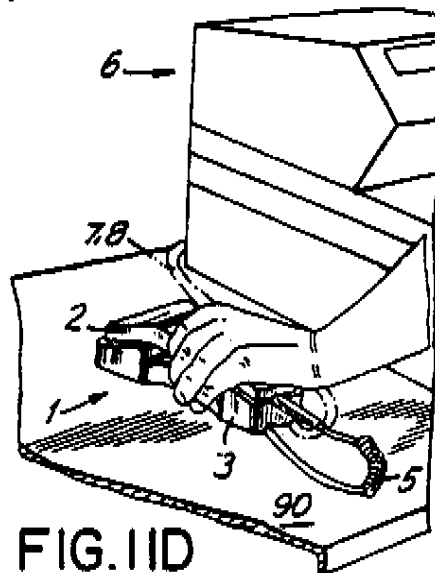

FIG. IID

U.S. Patent

Jul. 20, 1999

Sheet 16 of 19

5,925,870

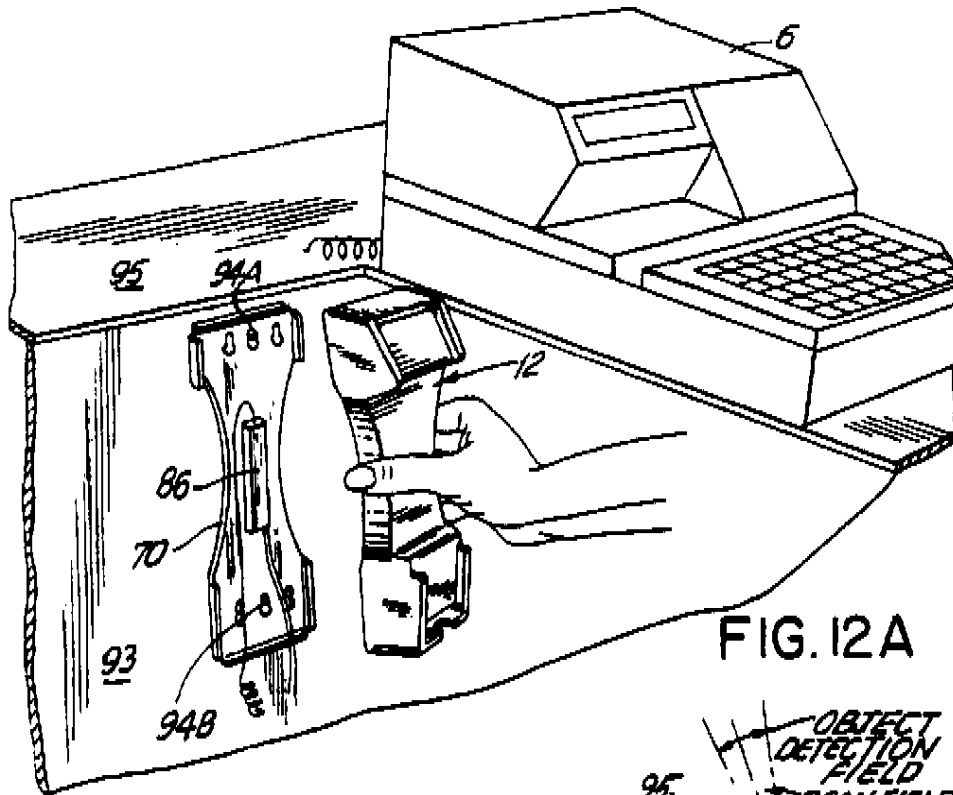

FIG. 12A

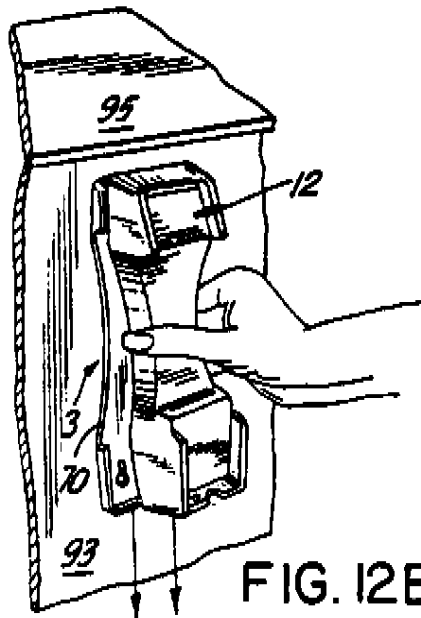

FIG. 12B

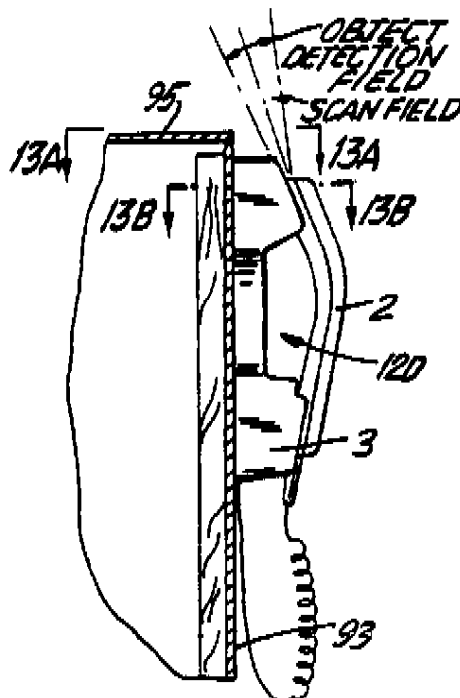

FIG. 13

U.S. Patent

Jul. 20, 1999

Sheet 17 of 19

5,925,870

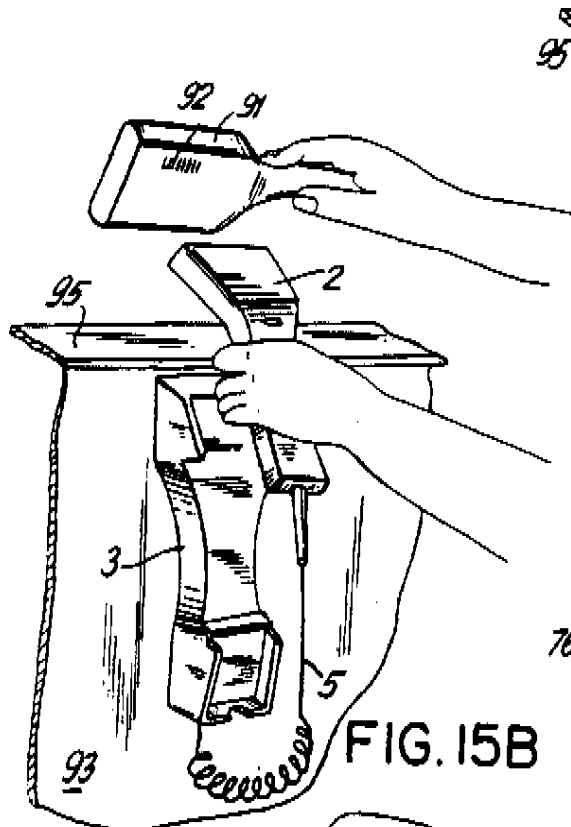

FIG. 15B

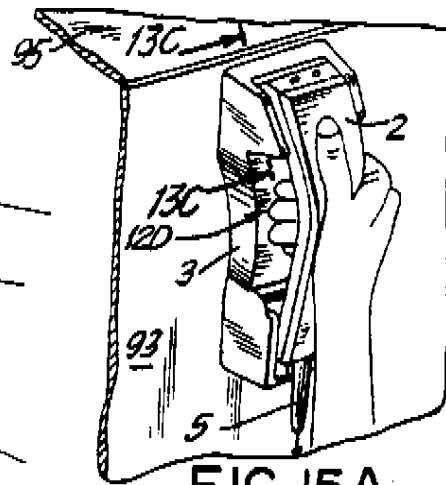

FIG. 15A

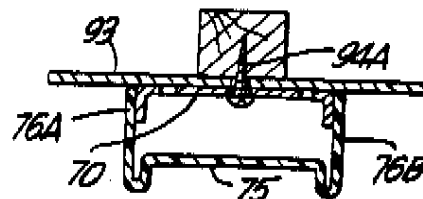

FIG. 13B

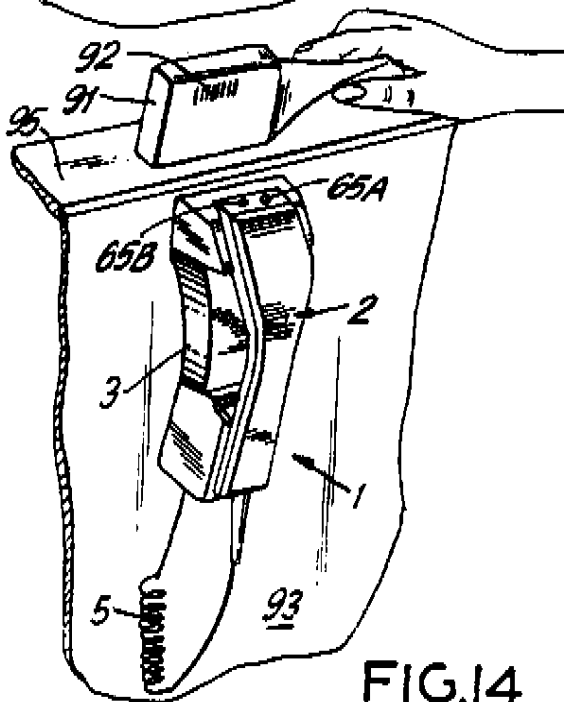

FIG. 14

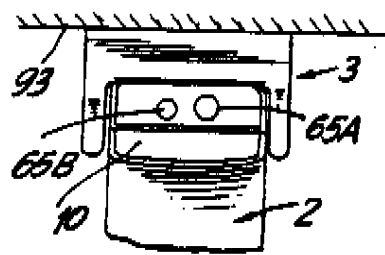

FIG. 13A

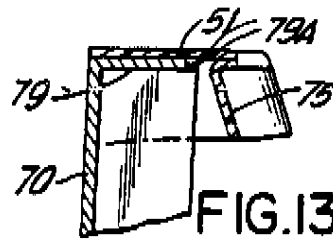

FIG. 13C

U.S. Patent

Jul. 20, 1999

Sheet 18 of 19

5,925,870

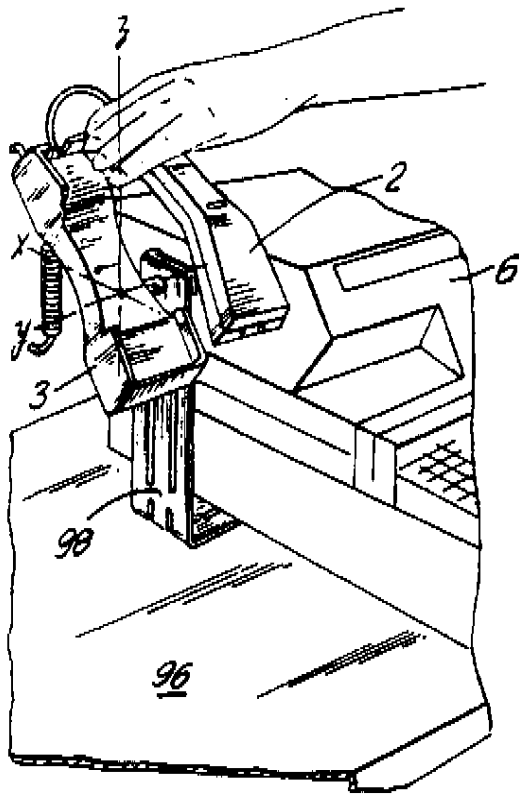

FIG. 17A

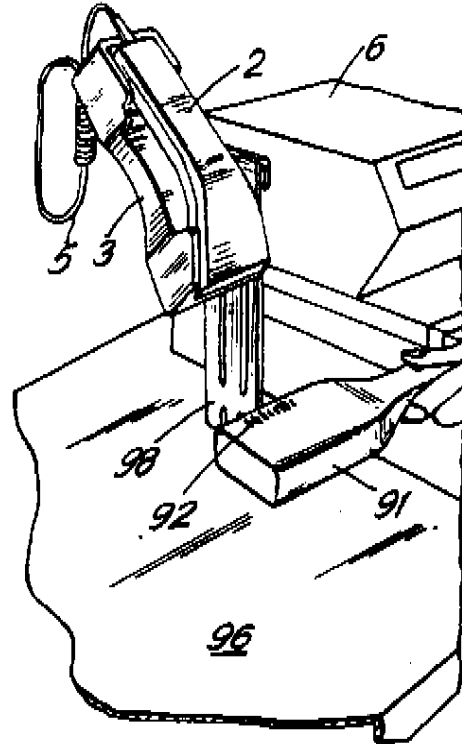

FIG. 16

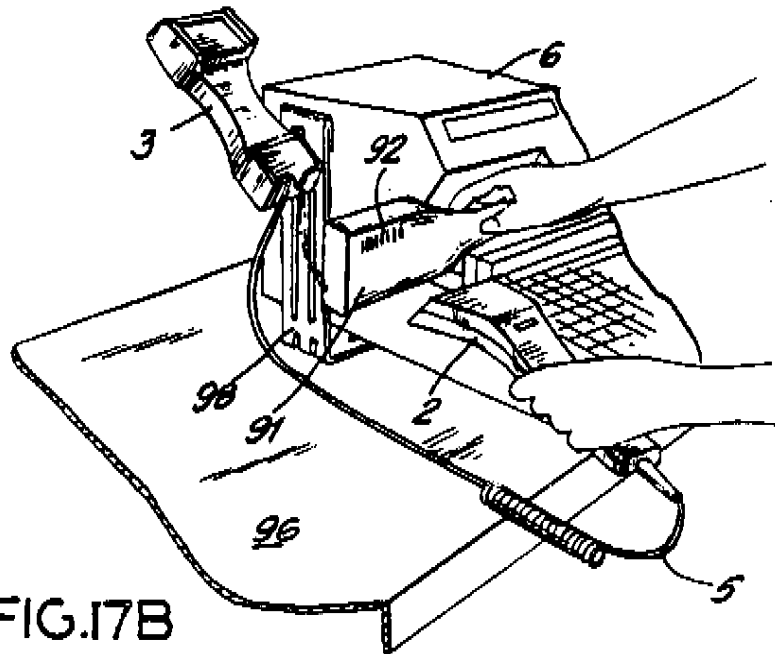
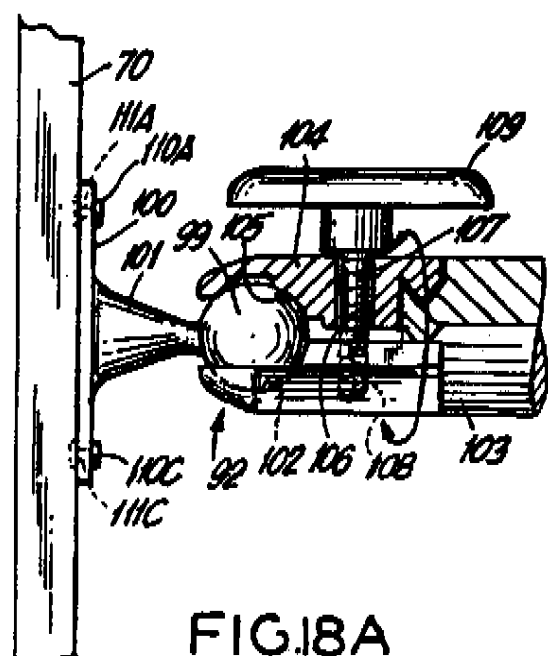
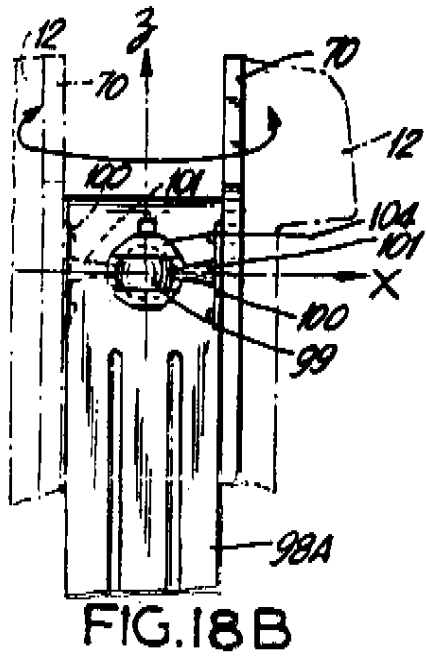
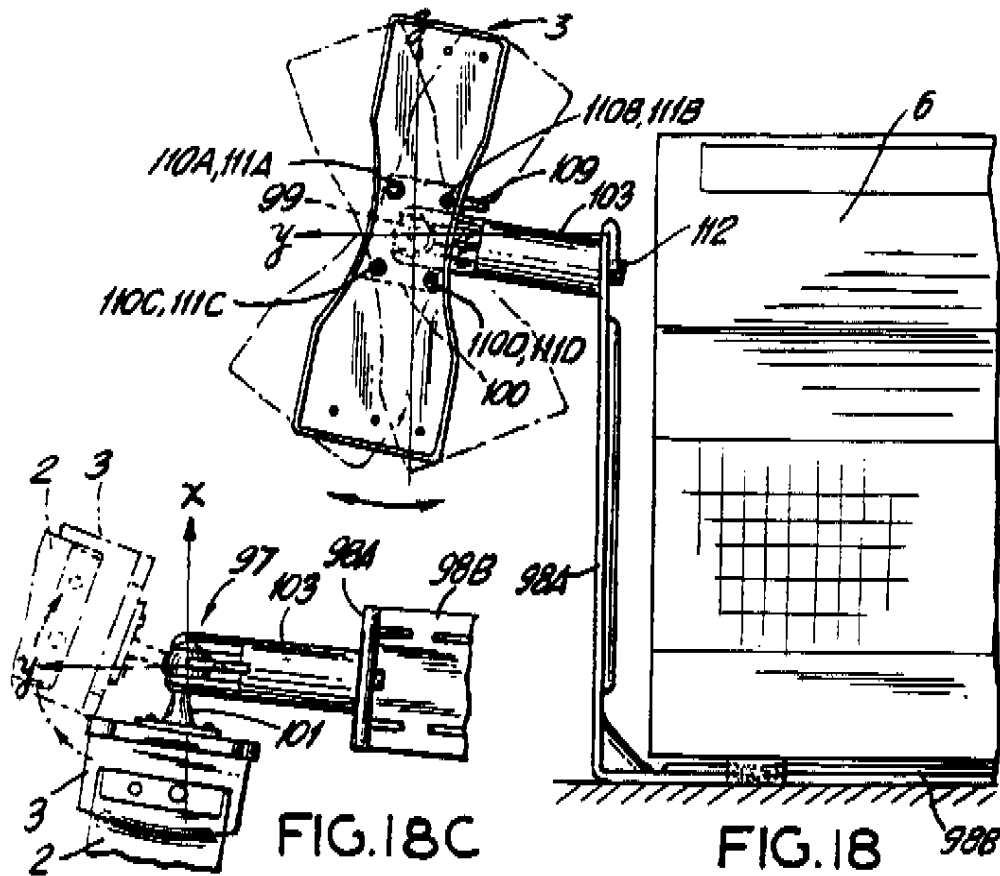

FIG. 17B



5,925,870

1

**AUTOMATIC HAND-SUPPORTABLE LASER
BAR CODE SYMBOL SCANNING DEVICE
AND METHOD OF SCANNING BAR CODES
USING SAME**

Continuation of Ser. No. 584,135, Jan. 11, 1996, U.S. Pat. No. 5,616,908, which is a continuation of Ser. No. 278,109, Nov. 24, 1993, U.S. Pat. No. 5,484,992, which is a continuation of Ser. No. 960,733, Oct. 14, 1992, abandoned, which is a continuation-in-part of Ser. No. 898,919, Jun. 12, 1992, U.S. Pat. No. 5,340,973, which is a continuation-in-part of Ser. No. 761,123, Sep. 17, 1991, U.S. Pat. No. 5,340,971, which is a continuation-in-part of Ser. No. 583,421, Sep. 17, 1990, U.S. Pat. No. 5,260,553.

BACKGROUND OF THE INVENTION

1. Field of the Invention

The present invention relates generally to laser scanning systems, and more particularly to an automatic bar code symbol reading system having an automatic hand-supportable laser scanner which can be utilized in diverse lighting environments with natural hand movements, while conserving electrical power.

2. Brief Description of the Prior Art

Bar code symbols have become widely used in many commercial environments such as, for example, point-of-sale (pos) stations in retail stores and supermarkets, inventory and document tracking, and diverse data control applications.

To meet the growing demands of this recent innovation, bar code symbol readers of various types have been developed for scanning and decoding bar code symbol patterns. Typically, the symbol character data produced from such bar code readers is provided as input to automated data processing systems.

In general, prior art hand-held bar code symbol readers using laser scanning mechanisms can be classified into three categories.

The first category of hand-held bar code symbol readers includes systems having manually-actuated laser scanners which can be supported in the hand of the user. The user positions the hand-held laser scanner at a specified distance from the object bearing the bar code symbol, manually activates the scanner to initiate reading (e.g. by pulling a trigger), and then moves the scanner over other objects bearing bar code symbols to be read. Prior art bar code symbol readers illustrative of this first category are disclosed in U.S. Pat. No. 4,387,297 to Swartz; U.S. Pat. No. 4,575,625 to Knowles; U.S. Pat. No. 4,639,606 to Boles et al.; U.S. Pat. No. 4,845,349 to Cherry; U.S. Pat. No. 4,825,057 to Swartz, et al.; U.S. Pat. No. 4,903,848 to Knowles; U.S. Pat. No. 4,933,538 to Heiman, et al.; U.S. Pat. No. 5,107,100 to Shepard, et al.; U.S. Pat. No. 5,080,456 to Katz, et al.; and U.S. Pat. No. 5,047,617 to Shepard et al.

The second category of hand-held bar code symbol readers includes systems utilizing hand-held scanners which have (i) a tungsten bulb, a Xenon lamp, or light emitting diodes (LEDs) to radiate light onto a bar code symbol, and (ii) an electronically scanned image sensor (e.g. CCD array) for converting the image of light reflected off the bar code symbol into a corresponding signal for decode processing. Exemplary systems of this type are disclosed in U.S. Pat. No. 4,570,057 to Chadima, et al.; U.S. Pat. No. 4,818,847 to Hara, et al and U.S. Pat. No. 4,877,949 to Danielson, et al.

The third category of hand-held bar code symbol readers includes systems utilizing fully automated hand-held laser

2

scanners having intelligent programs which control the operation device under diverse user operating conditions. Exemplary systems of this type of bar code symbol reading technology are disclosed in pending U.S. application Ser. Nos. 07/898,919 and 07/761,123.

While prior art hand-held manually triggered and CCD type scanners have played an important role in the development of the bar code symbol industry, these devices, suffer from a number of shortcomings and drawbacks. For example, hand-held manually-actuated laser scanners, although portable and lightweight, are not always convenient to use particularly in applications where the user must read bar coded objects over an extended period of time. In many applications, where bar coded objects to be identified reside at arms length from the user's reach, hand-held CCD scanners are difficult to operate owing to their limited depth of field.

Unlike manually automated hand-held bar code scanners, fully automatic hand-held laser scanners do not cause fatigue due to their automatic operation. Also, owing to their extended depth of field, automatic hand-held laser scanners provide increased flexibility by allowing the user to read bar coded objects residing at distances of six or more inches away from the scanner. However, even though automatic hand-held laser bar code scanners offer superior performance in most scanning applications, it has been found that in intensely illuminated scanning environments, the user's ability to perceive the visible laser scanning beam is significantly diminished in the scan field of the device. Consequently, in such scanning environments, it is difficult to visually align (i.e. register) the laser scanning beam with the bar code symbol to be scanned, thus hindering the Automatic bar code symbol reading process. While the use of a higher power visible laser beam might render the beam more easily perceptible, this approach is undesirable for laser safety and power consumption reasons.

Thus, there is a great need in the bar code symbol reading art for a hand-supportable laser bar code symbol reading system which overcomes the above described shortcomings and drawbacks of prior art devices and techniques, while permitting use over a diverse range of laser scanning environments.

**OBJECTS AND SUMMARY OF THE
INVENTION**

Accordingly, it is a primary object of the present invention to provide an automatic hand-supportable laser scanning device which utilizes psychophysiological response characteristics of the human visual system in order to produce a visible laser scanning beam that has improved user perceptibility over the scan field of the device.

A further object of the present invention is to provide such an automatic hand-supportable laser scanning device in which a visible laser beam is pulsed at a sufficient low frequency over the scan field of the device during its bar code presence detection mode of operation, so as to increase the visual conspicuousness of the laser scanning beam.

It is another object of the present invention to provide such an automatic bar code symbol reading system in which one or more bar code symbols on an object can be consecutively read without requiring unnatural hand-movements of the automatic hand-supportable laser scanning device.

A further object is to provide such an automatic bar code symbol reading system, in which the automatic hand-supportable bar code (symbol) scanning device has an infrared light object detection field which spatially encom-

5,925,870

3

passes at least a portion of its visible laser light scan field along the operative scanning range of the device, thereby improving the laser beam pointing efficiency of the device during the automatic bar code reading process of the present invention.

Another object of the present invention is to provide an automatic bar code symbol reading system in which the hand supportable laser scanning device can be used as either a portable hand-supported laser scanner in an automatic hands-on mode of operation, or as a stationary laser projection scanner in an automatic hands-free mode of operation.

Another object of the present invention is to provide such an automatic bar code reading system in which a support frame is provided for supporting the hand-supportable housing of the device in a selected mounting position, and permitting complete gripping of the handle portion of the hand-supportable housing prior to removing it from the support frame.

A further object of the present invention is to provide such an automatic bar code symbol reading system in which the hand-supportable bar code reading device has long and short-range modes of object detection within its object detection field. In one illustrative embodiment, the long and short-range modes of object detection are manually selectable by the user by manual activation of a switch on the hand-supportable housing of the device. In another illustrative embodiment, the long-range mode of object detection is automatically selected when the hand-supportable bar code reading device is placed within the support stand during the hands-free mode of operation. In this illustrative embodiment, the short-range mode of object detection is automatically selected whenever the hand-supportable bar code reading device is picked up from the support stand and used in its hands-on mode of operation. A further object of the present invention is to provide such an automatic bar code symbol reading system, in which the hand-supportable bar code reading device has long and short-range modes of bar code presence detection within its scan field. In one illustrative embodiment, the short-range mode of bar code presence detection is manually selectable by manual activation of a switch on the hand-supportable housing of the device. In another illustrative embodiment, the short-range mode of bar code presence detection is automatically selected when the hand-supportable bar code reading device is placed within the support stand, or alternatively, upon decoding a predesignated bar code symbol preprogrammed to induce the short-range mode of bar code presence detection. In the short-range mode of bar code presence detection, the automatic bar code reading device not only detects the presence of a bar code within the scan field by analysis of collected scan data, but it further processes the collected scan data to produce digital count data representative of the measured time interval between bar and/or space transitions. Bar code symbols present within the short-range of the scan field, produce scan data having time interval characteristics falling within a prespecified timing data range. Using the results of this analysis, only bar code symbols scanned within the short-range field are deemed "detected," and only bar code symbols detected within the short-range of the scan field activate the decoding module of the device and thus enable bar code symbol reading.

A further object of the present invention is to provide such an automatic bar code symbol reading system in which the hand-supportable bar code reading device has long and short-range modes of bar code symbol reading within its scan field.

In one illustrative embodiment, the long and short-range modes of bar code symbol reading are manually selectable

4

by the user by manual activation of a switch on the hand-supportable housing of the device.

It is a further object of the present invention to provide such an automatic bar code symbol reading system, in which the long-range mode of object detection is automatically selected when the hand-supportable bar code reading device is placed within the support stand during the hands-free mode of operation, or alternatively, upon decoding a pre-designated bar code symbol preprogrammed to induce the mode of bar code symbol reading. In this illustrative embodiment, the short-range mode of object detection is automatically selected whenever the hand-supportable bar code reading device is picked up from the support stand and used in its hands-on mode of operation. In this short-range mode of bar code symbol reading, the only decoded bar code symbols residing within the short-range portion of the scan field, are deemed "read".

It is another object of the present invention to provide an automatic hand-supportable bar code reading device which has both long and short-range modes of object detection and bar code symbol reading, automatically selectable by placing the hand-supportable device within its support stand and removing it therefrom. With this particular embodiment of the present invention, the automatic bar code symbol reading system can be used in various bar code symbol reading applications, such as, for example, charge coupled device (CCD) scanner emulation and bar code "menu" reading in the hands-on short-range mode of operation, and counter-top projection scanning in the hands-free long-range mode of operation.

An even further object of the present invention is to provide an automatic hand-supportable bar code reading device which prevents multiple reading of the same bar code symbol due to dwelling of the laser scanning beam upon a bar code symbol for an extended period of time.

A further object of the present invention is to provide a point-of-sale station incorporating the automatic bar code symbol reading system of the present invention.

It is a further object of the present invention to provide an automatic hand-supportable bar code reading device having a control system which has a finite number of states through which the device may pass during its automatic operation, in response to diverse conditions automatically detected within the object detection and scan fields of the device.

It is yet a further object of the present invention to provide a portable, fully automatic bar code symbol reading system which is compact, simple to use and versatile.

Yet a further object of the present invention is to provide a novel method of reading bar code symbols using an automatic hand-supportable laser scanning device.

These and further objects of the present invention will become apparent hereinafter and in the claims.

BRIEF DESCRIPTION OF THE DRAWINGS

For a fuller understanding of the objects of the present invention, the Detailed Description of the Illustrated Embodiment of the Present Invention will be taken in connection with the drawings, wherein:

FIG. 1 is a perspective view of the illustrative embodiment of the automatic bar code symbol reading system of the present invention, showing the hand-supportable laser bar code symbol reading device supported within the scanner support stand for automatic hands-free operation;

FIG. 1A is an elevated front view of the automatic bar code symbol reading system of FIG. 1, showing the light

5,925,870

5

transmission window of the hand-supportable bar code symbol reading device while supported within the scanner support stand;

FIG. 1B is a plan view of the automatic bar code symbol reading system shown in FIG. 1;

FIG. 1C is a bottom view of the automatic bar code symbol reading system shown in FIG. 1;

FIG. 2 is a perspective view of the automatic hand-supportable bar code symbol reading device of the system hereof, shown being used in the automatic hands-on mode of operation;

FIG. 2A is an elevated, cross-sectional side view taken along the longitudinal extent of the automatic bar code symbol reading device of FIG. 2, showing various hardware and software components utilized in realizing the illustrative embodiment of the automatic hand-supportable bar code symbol reading device of the present invention;

FIG. 2B is a cross-sectional plan view taken along line 2B—2B of FIG. 2A, showing the various components used in realizing the illustrative embodiment of the automatic bar code symbol reading device;

FIG. 2C is an elevated partially fragmented cross-sectional view of the head portion of the automatic hand-supportable bar code symbol reading device of the present invention, illustrating an electro-optical arrangement utilized in transmitting pulsed infrared light signals over the object detection field of the device;

FIG. 2D is an elevated partially fragmented cross-sectional view of the head portion of the automatic hand-supportable bar code symbol reading device of the present invention, illustrating the electro-optical arrangement utilized in producing the object detection field of the device;

FIG. 3 is an elevated side view of the hand-supportable bar code symbol reading device of the illustrative embodiment of the present invention, illustrating the spatial relationship between the object detection and scan fields of the device, and the long and short-ranges of programmed object detection, bar code presence detection, and bar code symbol reading;

FIG. 3A is a plan view of the automatic hand-supportable bar code symbol reading device taken along line 3A—3A of FIG. 3;

FIG. 4 is a system block functional diagram of the automatic hand-supportable bar code symbol reading device of the present invention, illustrating the principal components integrated with the system controller thereof;

FIG. 5 is a block functional diagram of a first embodiment of the object detection mechanism for the automatic hand-supportable bar code symbol reading device of the present invention;

FIG. 6 is a schematic diagram illustrating the intensity versus time characteristics of the visible laser scanning beam produced during the bar code presence detection mode of operation of the automatic hand-supportable bar code symbol reading device of the present invention;

FIGS. 7A and 7B, taken together, show a high level flow chart of a system control program (i.e. Main System Control Routine) contained within the control system of the automatic bar code symbol reading device, illustrating various courses of programmed system operation that the illustrative embodiment may undergo;

FIGS. 8A, 8A', 8B and 8B' taken together, show a high level flow chart of an auxiliary system control program (i.e. Auxiliary System Control Routine with Range Selection), which provides the hand-supportable automatic bar code

6

symbol reading device of the present invention with several selectable modes of object detection, bar code presence detection and bar code symbol reading;

FIG. 9 is a state diagram illustrating the various states that the automatic hand-supportable bar code symbol reading device of the illustrative embodiment may undergo during the course of its programmed operation;

FIG. 10 is a perspective view of the support frame of the scanner support stand of the present invention;

FIG. 10A is a perspective view of the base plate of the scanner support stand of the present invention, with the adapter module mounted thereon;

FIG. 10B is a perspective, partially broken away view of the assembled scanner support stand of the present invention, showing the scanner cable, power supply cable and communication cable operably associated therewith and routed through respective apertures formed in the scanner support frame;

FIGS. 11A through 11D are perspective views of a point-of-sale system, showing the scanner support stand of the present invention supported on a horizontal countertop surface and operably connected to an electronic cash register, with the automatic hand-supportable bar code symbol reading device being used in its hand-held short-range mode of operation;

FIGS. 12A and 12B are perspective views illustrating the steps carried out during the installation of the scanner support stand of the present invention onto a vertical counter wall surface;

FIG. 13 is an elevated side view of the automatic bar code symbol reading system of the present invention, shown mounted onto the vertical counter wall surface of FIGS. 12A and 12B;

FIG. 13A is a plan view of the automatic bar code symbol reading system of the present invention taken along line 13A—13A of FIG. 13;

FIG. 13B is a cross-sectional view of the scanner support stand of the present invention, taken along line 13B—13B of FIG. 13;

FIG. 13C is a cross-sectional view of the assembled scanner stand, taken along line 13C—13C of FIG. 13A;

FIG. 14 is perspective views showing the scanner support stand mounted on a vertical counter wall surface, and the automatic hand-supportable bar code symbol reading device being used in its automatic hands-free long-range mode of operation;

FIGS. 15A and 15B are perspective views showing the scanner support stand mounted on a vertical counter wall surface, and the automatic hand-supportable bar code symbol reading device being used in its automatic hand-held short-range mode of operation;

FIG. 16 is a perspective view of a point-of-sale station according to the present invention, showing the scanner support stand pivotally supported above a horizontal counter surface by way of a pedestal base mounted under an electronic cash register, and the automatic hand-supportable bar code symbol reading device received in the scanner support stand and being used in its automatic hands-free long-range mode of operation;

FIGS. 17A and 17B are perspective views of a point-of-sale station according to the present invention, showing the scanner support stand pivotally supported above a horizontal counter surface by way of the pedestal base illustrated in FIG. 16, and the automatic hand-supportable bar code symbol reading device being used in its automatic hand-held short-range mode of operation;

5,925,870

7

FIG. 18 is an elevated side view of the point-of-sale system of FIGS. 16A, 16B and 17, illustrating the rotational freedom of the scanner support stand about the x axis of the pivotal joint assembly;

FIG. 18A is an elevated, partially cross-sectional view of the base plate of the scanner support stand and the pivotal joint assembly connecting the scanner support stand to the pedestal base so as to provide three-degrees of freedom to the scanner support stand with respect to the stationary pedestal base;

FIG. 18B is a partially fragmented view of the scanner support stand, pivotal joint assembly and pedestal base taken along the y axis of the pivotal joint assembly, illustrating the rotational freedom of the scanner support stand about the y axis; and

FIG. 18C is a perspective view of the scanner support stand and pedestal base assembly taken along the -z axis of the pivotal joint assembly, illustrating the rotational freedom of the scanner support stand about the z axis of the pivotal joint assembly.

DETAILED DESCRIPTION OF THE ILLUSTRATED EMBODIMENT OF THE PRESENT INVENTION

In FIGS. 1 and 11A through 11D, the automatic laser bar code symbol reading system of the present invention is illustrated. As shown, automatic bar code symbol reading system 1 comprises a portable, automatic hand-supportable bar code (symbol) reading device 2 operably associated with scanner support stand 3 of the present invention. Operable interconnection of hand-supportable bar code reading device 2 and scanner support stand 3 is achieved by a flexible multiwire scanner cable 5 extending from bar code symbol device 2 into scanner support stand 3. Operable interconnection of scanner support stand 3 and a host system 6 (e.g. electronic cash register system, data collection device, etc.) is achieved by a flexible multiwire communications cable 7 extending from scanner support stand 3 and plugged directly into the data-input communications port of host system 6. In the illustrative embodiment, electrical power from a low voltage power supply (not shown) is provided to scanner support stand 3 by way of a flexible power cable 8.

As illustrated in FIGS. 1 through 1C, scanner support stand 3 is particularly adapted for receiving and supporting hand-supportable bar code reading device 2 in a selected position without user support, thus providing a stationary, automatic hands-free mode of operation. In general, hand-supportable bar code reading device 2 includes an ultra-light weight hand-supportable housing 9 having a contoured handle portion 9A and a head portion 9B. As will be described in greater detail hereinafter, head portion 9B encloses electro-optical components which are used to generate and project a visible laser beam through a light transmissive window 10, and to repeatedly scan the projected laser beam across a scan field 11 defined external to the hand-supportable housing.

As illustrated in FIGS. 1 through 1C, scanner support stand 3 includes a support frame 12 which comprises a base portion 12A, a head portion support structure 12B, handle portion support structure 12C and a finger accommodating recess 12D. As shown, base portion 12A has a longitudinal extent and is adapted for selective positioning with respect to a support surface, e.g. countertop surface, counter wall surface, etc. Head portion support structure 12B is operably associated with base portion 12A, for receiving and supporting the head portion of the hand-supportable bar code

8

reading device. Similarly, handle portion support structure 12C is operably associated with base portion 12A, for receiving and supporting the handle portion of the hand-supportable bar code symbol reading device. In order that the user's hand can completely grasp the handle portion of the hand-supportable bar code reading device, that is prior to removing it off and away from the scanner support stand as illustrated in FIG. 15A, finger accommodating recess 12D is disposed between head and handle portion support structures 12B and 12C and above base portion 12A of the support frame. In this way, finger accommodating recess 12D is laterally accessible as shown in FIG. 13 so that when the handle and head portions 9A and 9B are received within and supported by handle portion support structure 12B and head portion support structure 12C, respectively, the fingers of a user's hand can be easily inserted through finger accommodating recess 12D and completely encircle the handle portion of the hand-supportable device, as illustrated in FIG. 15A.

A more detailed description of the structure, functions and operation of the scanner support stand of the present invention will be provided hereinafter referring to FIGS. 10 through 16B. However, referring to FIGS. 1 and 10 through 13, attention will be first accorded to the illustrative embodiment of the automatic hand-supportable bar code reading device of the invention.

As illustrated in FIGS. 2 through 2B in particular, head portion 9B continuously extends into contoured handle portion 9A at an obtuse angle α which, in the illustrative embodiment, is about 146 degrees. It is understood, however, that in other embodiments obtuse angle α may be in the range of about 135 to about 180 degrees. As this ergonomic housing design is sculptured (i.e. form-fitted) to the human hand, automatic hands-on scanning is rendered as easy and effortless as waving ones hand. Also, this ergonomic housing design eliminates the risks of musculoskeletal disorders, such as carpal tunnel syndrome, which can result from repeated biomechanical stress commonly associated with pointing prior art gun-shaped scanners at bar code symbols, squeezing a trigger to activate the laser scanning beam, and then releasing the trigger.

As illustrated in FIGS. 2 through 3A, the head portion of housing 9 has a transmission aperture 13 formed in upper portion of front panel 14A, to permit visible laser light to exit and enter the housing, as will be described in greater detail hereinafter. The lower portion of front panel 14B is optically opaque, as are all other surfaces of the hand supportable housing.

As illustrated in FIGS. 2, 3 and 3A in particular, automatic hand-supportable bar code reading device 2 generates two different fields external to the hand-supportable housing, in order to carry out automatic bar code symbol reading according to the principles of the present invention. The first field, referred to as the "object detection field", indicated by broken and dotted lines, is provided externally to the housing for detecting energy reflected off an object bearing a bar code symbol, located within the object detection field. The second field, referred to as the "scan field", having at least one laser beam scanning plane is provided external to the housing for scanning a bar code symbol on an object in the object detection field. In the preferred embodiment, such scanning is achieved with a visible laser beam which, after reflecting off an object in the object detection field, produces laser scan data which is collected for the purpose of detecting the presence of a bar code symbol within the scan field, and for subsequently reading (i.e. scanning and decoding) the detected bar code symbol.

5,925,870

9

In general, detected energy reflected from an object during object detection can be optical radiation or acoustical energy, either sensible or non-sensible by the user, and may be either generated from the automatic bar code reading device or an external ambient source. As will be described in greater detail hereinafter, the provision of such energy is preferably achieved by transmitting a wide beam of pulsed infrared (IR) light away from transmission aperture 13, substantially parallel to longitudinal axis 15 of the head portion of the hand-supportable housing. In the preferred embodiment, the object detection field, from which such reflected energy is collected, is designed to have a narrowly diverging pencil-like geometry of three-dimensional volumetric expanse, which is spatially coincident with at least a portion of the transmitted infrared light beam. This feature of the present invention ensures that an object residing within the object detection field will be illuminated by the infrared light beam, and that infrared light reflected therefrom will be directed generally towards the transmission aperture of the housing where it can be automatically detected to indicate the presence of the object within the object detection field. In response, a visible laser beam is automatically generated within the head portion of the housing, projected through the transmission aperture and repeatedly scanned across the scan field, within which at least a portion of the detected object will reside. At least a portion of the scanned laser light beam will be scattered and reflected off the object and directed back towards and through light transmissive window 10 for collection and detection within the head portion of the housing, and subsequently processed in a manner which will be described in detail hereinafter. To ensure that the user can quickly align the visible laser beam with bar code symbol on the detected object, the object detection field is designed to spatially encompass at least a portion of the scan field along the operative scanning range of the device, as illustrated in FIGS. 3 and 3A. This structural feature of the present invention provides the user with an increased degree of control, as once an object is detected, minimal time will be required by the user to point the visible laser beam towards the bar code symbol for scanning. In effect, the laser beam pointing efficiency of the device is markedly improved during the automatic bar code reading process, as it is significantly easier for the user to align the laser beam across the bar code symbol upon object detection.

To more fully appreciate the mechanisms employed in order to generate the object detection and scan fields of automatic bar code reading device of the present invention, reference is best made to the operative elements contained within the hand-supportable housing of the device.

As shown in FIG. 4, automatic bar code reading device 2 comprises a number of system components, namely, an object detection circuit 16, laser scanning mechanism 17, photoreceiving circuit 18, analog-to-digital (A/D) conversion circuit 19, bar code presence detection module 20, bar code scan range detection module 21, symbol decoding module 22, data format conversion module 23, symbol character data storage unit 24, and data transmission circuit 25. In addition, a magnetic field sensing circuit 26 is provided for detecting scanner support stand 3, while a manual switch 27 is provided for selecting long or short-range modes of object detection, bar code presence detection and/or bar code symbol reading, which will be described in great detail hereinafter. As illustrated, these components are operably associated with a programmable system controller 28 which provides a great degree of versatility in system control, capability and operation. The structure, function and advantages of this system controller will become apparent hereinafter.

10

In the illustrated embodiment, system controller 28, bar code presence detection module 20, bar code scan range detection module 21, symbol decoding module 22, and data format conversion module 23 are realized using a single programmable device, such as a microprocessor having accessible program and buffer memory, and external timing circuitry. It is understood, however, that any of these elements may be realized using separate discrete components as will be readily apparent to those with ordinary skill in the art.

Automatic hand-supportable bar code reading device 2 also includes power receiving lines 29 which lead to conventional power distribution circuitry (not shown) for providing requisite power to each of the system components, when and for time prescribed by the system controller. As illustrated, power receiving lines 29 run alongside data communication lines 30 and are physically associated with multi-pin connector plug 31 at the end of flexible scanner cable 5. An on/off power switch or functionally equivalent device (not shown) may be provided external the hand-supportable housing to permit the user to selectively energize and deenergize the device. In the illustrative embodiment, power delivered through flexible scanner cable 5 to the bar code symbol reading device is continuously provided to system controller 28 so as to continuously enable its operation, while only biasing voltages and the like are provided to all other system components. In this way, each system component must be activated (i.e. enabled) by the system controller in accordance with its preprogrammed system control routine.

In accordance with the present invention, the purpose of the object detection circuit is to determine whether an object (e.g., product, document, etc.) is present or absent from the object detection field over particular time intervals specified by the system controller. When an object is detected within the object detection field, the object detection circuit produces first control activation signal $A_1=1$, which like all control activation signals, is provided as input to system controller 28. As will be described in greater detail hereinafter, depending on the particular stage of the system control process, the system controller will respond to this event by causing the bar code reading device to undergo a transition from the object detection state to the bar code symbol (presence) detection state.

In FIG. 5, a preferred technique is disclosed for detecting the presence of an object within the object detection field. In essence, object detection circuit 16A operates by transmitting a pulsed infrared (IR) light signal forwardly into the object detection field. First control activation signal A_1 is generated upon receiving a reflection of the transmitted signal from an object residing within the object detection field. As illustrated, object detection circuit 16A is realized as an IR sensing circuit which comprises a synchronous receiver/transmitter 33 and an infrared LED 34 which generates a 940 nanometer pulsed signal at a rate of 20.0 KHZ. This pulsed IR signal is transmitted through focusing lens 35 to illuminate the object detection field. When an object is present within the object detection field, a reflected IR pulse signal is produced from the surface of the object, spatially filtered by aperture stop 65B and focused through focusing lens 36 onto photodiode 37. Notably, (i) selection of the optical characteristics of aperture stop 65B and lens 36 and (ii) the placement of photodiode 37 (with integrally formed lens 36) behind aperture stop 65B directly determine the geometric characteristics of the object detection field. Consequently, these optical parameters are selected so as to provide an object detection field which, as hereinbefore

5,925,870

11

explained, spatially encompasses at least a portion of the scanning field along the operative scanning range of the device.

As illustrated in FIG. 5, the output of photodiode 37 is converted to a voltage by current-to-voltage amplifier 38, and the output thereof is provided as input to synchronous receiver/transmitter 33 which synchronously compares the received IR signal with the transmitted IR signal to determine whether an object is present in or absent from the object detection field. If the object is present in the object detection field, then synchronous receiver/transmitter 33 produces first control activation signal $A_1=1$, indicative of this condition. Upon generation of first control activation signal $A_1=1$, the system controller activates the operation of laser scanning mechanism 17, photoreceiving circuit 18, A/D conversion circuit 19, and bar code presence detection module 20 according to a preprogrammed system control routine, the details of which will be described hereinafter.

Alternatively, the automatic bar code reading device of the present invention can be readily adapted to sense ultrasonic energy reflected off an object present within the object detection field. In such an alternative embodiment, object detection circuit 16 is realized as an ultrasonic energy transmitting/receiving mechanism. In the head portion of hand-supportable housing 9, ultrasonic energy is generated and transmitted forwardly of the housing head portion into the object detection field. Then, ultrasonic energy reflected off an object within the object detection field is detected closely adjacent the transmission window using an ultrasonic energy detector. Preferably, a focusing element is disposed in front of the detector in order to effectively maximize the collection of reflected ultrasonic energy. In such instances, the focusing element essentially determines the geometrical characteristics of the object detection field of the device. Consequently, as with the other above-described object detection circuits, the energy focusing (i.e. collecting) characteristics of the focusing element will be selected to provide an object detection field which spatially encompasses at least a portion of the scan field.

For purposes of illustration, object detection circuit 16 shown in FIG. 5, is provided with two different modes of detection, namely, a long-range mode of object detection and a short-range mode of object detection. As shown in FIG. 4, these modes are set by the system controller using mode enable signals $E_{LR}=0$ and $E_{SR}=1$, respectively. When induced into the long-range mode of object detection, the IR sensing circuit will generate first control activation signal $A_1=1$ whenever an object has been detected within the operative range of the object detection field, independent of the particular distance at which the object resides from the transmissive window. When induced into the short-range mode of object detection, the IR sensing circuit will generate first activation control signal $A_1=1$ only when an object is detected at a distance within the short-range of the object detection field.

As schematically indicated in FIGS. 3 and 3A, the long-range specification for object detection is preferably preselected to be the full or entire range of sensitivity provided by IR sensing circuit 16A (e.g. 0 to about 10 inches). Preferably, the short-range specification for object detection is preselected to be the reduced range of sensitivity provided by the IR sensing circuit when mode enable signal $E_{SR}=1$ is provided to the desensitization port of synchronous receiver/transmitter 33. In the illustrated embodiment, the short-range of object detection is about 0 to about 3 inches or so to provide CCD-like scanner emulation. As will become apparent hereinafter, the inherently limited depth and width

12

of field associated with the short-range mode of object detection prevents laser scanning mechanism 17 from flooding the scan field with laser scanning light and thus inadvertently detecting undesired bar code symbols. Particular uses to which object detection range selection can be put, will be described in greater detail hereinafter with reference to FIGS. 11A through 16B in particular.

As illustrated in FIG. 4, laser scanning mechanism 17 comprises a light source 50 which, in general, may be any source of intense light suitably selected for maximizing the reflectivity from the object's surface bearing the bar code symbol. In the illustrative embodiment, light source 50 comprises a solid-state visible laser diode (VLD) which is driven by a conventional driver circuit 51. The wavelength of visible laser light produced from the laser diode is preferably about 670 nanometers. In order to repeatedly scan the produced laser beam over a scan field having a predetermined spatial extent in front of the head portion of the housing as illustrated in FIGS. 3 and 3A, a planar scanning mirror 52 is oscillated back and forth by a stepper motor 53 driven by a conventional driver circuit 54. However, one of a variety of conventional laser scanning mechanisms may be alternatively used with excellent results. To selectively activate laser light source 50 and scanning motor 53, the system controller provides laser diode scanner enable signal E_L and scanning motor enable signal E_M , as input to driver circuits 51 and 54, respectively. When enable signal E_L is a logical "high" level (i.e., $E_L=1$) a laser beam is generated and projected through the light transmissive window 10 and when E_M is a logical high level the laser beam is repeatedly scanned across the scan field.

When a bar code symbol on an object is within the scan field at the time of scanning, the incident laser light on the bar code will be scattered and reflected. This scattering/reflection process produces a laser light return signal of variable intensity which represents a spatial variation of light reflectivity characteristic of the spaced apart pattern of bars comprising the bar code symbol. Photoreceiving circuit 18 detects at least a portion of the reflected laser light of variable intensity. Upon detection of this reflected laser light, photoreceiving circuit 18 produces an analog scan data signal D_1 indicative of the detected light intensity.

In the illustrative embodiment, photoreceiving circuit 18 generally comprises laser light collection optics 55, which focus reflected laser light for subsequent detection by a photoreceiver 56 having, mounted in front of its sensor, a frequency selective filter 57 which only transmits optical radiation of wavelengths up to a small band above 670 nanometers. Photoreceiver 56, in turn, produces an analog signal which is subsequently amplified by preamplifier 58 to produce analog scan data signal D_1 . In combination with laser scanning mechanism 17 and photoreceiving circuit 18 cooperate to generate analog scan data signals D_1 from the scan field over time intervals specified by the system controller. As will be illustrated hereinafter, these scan data signals are used by bar code presence detection module 20, bar code scan range detection module 21, and symbol decoding module 22 to perform particular functions.

As illustrated in FIG. 4, analog scan data signal D_1 is provided as input to A/D conversion circuit 19. As is well known in the art, A/D conversion circuit 19 processes analog scan data signal D_1 to provide a digital scan data signal D_2 which resembles, in form, a pulse width modulated signal, where logical "1" signal levels represent spaces of the scanned bar code and logical "0" signal levels represent bars of the scanned bar code. A/D conversion circuit 19 can be realized by any conventional A/D circuit well known to

5,925,870

13

those with ordinary skill in the art. Digitized scan data signal D_2 is then provided as input to bar code presence detection module 20, bar code scan range detection module 21 and symbol decoding module 22.

The purpose and function of bar code presence detection module 20 is to determine whether a bar code is present in or absent from the scan field over particular time intervals specified by the system controller. When a bar code symbol is detected in the scan field, bar code presence detection module 20 generates second control activation signal $A_2=1$ (i.e. $A_2=1$) which is provided as input to the system controller, as shown in FIG. 4. Preferably, bar code presence detection module 20 is realized as a microcode program carried out by the microprocessor and associated program and buffer memory, described hereinbefore. The function of the bar code presence detection module is not to carry out a decoding process, but rather to rapidly determine whether the received scan data signals represent a bar code symbol residing within the scan field.

There are a number of ways in which to achieve bar code presence detection through a programming implementation. For example, in the preferred embodiment, bar code presence detection module 20 detects the first and second borders of the bar code symbol "envelope". This is achieved by first processing a digital scan data signal D_2 to produce digital "count" and "sign" data. The digital count data is representative of the measured time interval (i.e. duration) of each signal level occurring between detected signal level transitions which occur in digitized scan data signal D_2 . The digital sign data, on the other hand, indicates whether the signal level between detected signal level transitions is either a logical "1", representative of a space, or a logical "0", representative of a bar within a bar code symbol. Using the digital count and sign data, the bar code presence detection module identifies the first and second borders of the bar code envelope, and thereby determines whether or not the envelope of a bar code symbol is represented by the scan data collected from the scan field. When a bar code symbol envelope is detected, the bar code symbol presence detection module provides second control activation signal $A_2=1$ to the system controller. As will be described in greater detail hereinafter, second control activation signal $A_2=1$ causes the device to undergo a transition from bar code presence detection state to bar code symbol reading state.

Similar to the object detection circuit described above, the bar code presence detection module is provided with two different modes of detection, namely: a long-range mode of bar code presence detection and a short-range mode of bar code presence detection. As shown in FIG. 4, these long and short-range modes are set by the system controller using mode select enable signals $E_{SCD}=0$ and $E_{SCD}=1$, respectively. When induced into the long-range mode of detection, the bar code presence detection module will generate second control activation signal $A_2=1$ whenever the envelope of a bar code symbol has been detected, despite the particular distance the bar code is from the light transmissive window. However, when induced into the short-range mode of detection, the bar code presence detection module will generate second control activation signal $A_2=1$ only when the envelope of a bar code symbol has been detected and when the associated digital count (i.e. timing) data indicates that the detected bar code resides within the short-range portion of the scan field.

Similar to long-range specification for object detection, long-range specification for bar code presence detection is preselected to be the entire operative scanning range available to the device. In an illustrative embodiment, this range

14

can be from about 0 to about 10 inches from the transmission aperture, depending on the optics employed in the laser scanning mechanism and the response characteristics of the photoreceiving circuit. These long and short-range specifications are schematically indicated in FIGS. 3 and 3A. In the preferred embodiment, short-range specification for bar code presence detection is preselected to be the same range selected for short-range object detection (e.g. approximately 0 to about 3 inches from the transmission aperture). As will become apparent hereinafter, the inherently limited depth and width of field associated with the short-range mode of bar code symbol detection, prevents the reading of detected bar code symbols residing outside the short-range portion of the scan field.

Unlike the bar code symbol presence detection module, the purpose and function of bar code scan range detection module 21 is not to detect the presence of a bar code symbol in the scan field, but rather to determine the range (i.e. distance) at which a detected or decoded bar code symbol resides from the light transmissive window of the housing. As will be explained in greater detail hereinafter, this data processing module operates upon digital scan data signal D_2 which has been previously utilized by either the bar code symbol detection module, or the symbol decoding module depending on the state of the system.

When the system is induced into its short-range mode of bar code presence detection, bar code presence detection module 20 does not automatically produce and provide second control activation signal $A_2=1$ to the system controller upon the detection of a bar code symbol in the scan field. Rather, when a bar code symbol has been detected, the bar code presence detection module first provides to the system controller, a second control activation signal $A_{2a}=1$, indicative of a detected bar code in the scan field. Then, bar code scan range detection module 21 analyzes digital count data D_{c1} produced by the bar code presence detection module, to determine at what range the detected bar code symbol resides from the light transmissive window. If scan range detection module 21 determines that the detected bar code symbol is located within the prespecified short-range portion of the scan field, then it provides second control activation signal $A_{2b}=1$ to the system controller; otherwise, the scan range detection module produces second control activation signal $A_{2b}=0$. Only when both control activation signals $A_{2a}=1$ and $A_{2b}=1$ are received by the system controller in this mode, does $A_2=1$ and thus the bar code reading device caused to undergo a transition from bar code symbol presence detection state to bar code symbol reading state.

Returning to FIG. 4, the function of symbol decoding module 22 is to process, scan line by scan line, the stream of digitized scan data D_2 , in an attempt to decode a valid bar code symbol within a predetermined time period allowed by the system controller. In general, when symbol decoding module 22 successfully decodes a bar code symbol within the predetermined time period, symbol character data D_3 (typically in ASCII code format) corresponding to the decoded bar code symbol is produced. Thereupon, a third control activation signal $A_3=1$ is produced by the symbol decoding module and is provided to the system controller in order to perform its system control functions.

Similar to the bar code presence detection module, the symbol decoding module is provided with two different modes of detection, namely: a long-range mode and a short-range mode of bar code symbol decoding. When the system is induced into its short-range mode of bar code symbol decoding, symbol decoding module 22 does not automatically generate third activation signal $A_3=1$ upon

5,925,870

15

decoding a valid bar code symbol. Rather, when a bar code symbol has been successfully decoded, the symbol decoding unit first provides to the system controller, a third activation control signal $A_3=1$, indicative of a decoded bar code symbol in the scan field. Then, bar code scan range detection module 21 analyzes digital count data $Dc2$ produced by the symbol decoding module, to determine at what range (i.e. distance) the decoded bar code symbol resides from the transmission aperture. If the bar code scan range detection module determines that the decoded bar code symbol resides within the prespecified short-range portion of the scan field, then it provides third control activation signal $A_{3s}=1$ to the system controller; otherwise, bar code scan range detection module produces third control activation signal $A_{3s}=0$. Only when both control activation signals $A_{3s}=1$ and $A_{3l}=1$ are received by the system controller in this mode, does $A_3=1$ and thus bar code reading device caused to undergo a transition from the bar code symbol reading state to the symbol character data transmission/storage state.

The long-range and short-range modes of bar code symbol detection and decoding described above each require the use of bar code scan range detection to determine whether or not the detected or decoded bar code symbol resides in the short or long-range portion of the scan field. As such, the use of this scan data processing technique permits the system of the present invention to condition the occurrence of particular events within the system control program. This feature of the present invention will be illustrated in great detail hereinafter when describing auxiliary system control routine of FIGS. 8A and 8B.

As will be illustrated in greater detail hereinafter with reference to FIGS. 8A and 8B, the system controller provides enable signals E_{FC} , E_{DS} and E_{DT} to data format conversion module 23, data storage unit 24 and data transmission circuit 25, respectively, at particular stages of its control program. As illustrated in FIG. 4, symbol decoding module 22 provides symbol character data D_3 to data format module 23 to convert data D_3 into two differently formatted types of symbol character data, namely D_4 and D_5 . Format-converted symbol character data D_5 is of the "packed data" format, particularly adapted for efficient storage in data storage unit 24. Format-converted symbol character data D_5 is particularly adapted for data transmission to host computer system 6 (e.g. an electronic cash register). When symbol character data D_4 is to be converted into the format of the user's choice (based on a selected option mode), the system controller provides enable signal E_{DS} to data storage unit 24, as shown in FIG. 4. Similarly, when format-converted data D_5 is to be transmitted to host device 6, the system controller provides enable signal E_{DT} to data transmission circuit 25. Thereupon, data transmission circuit 25 transmits format-converted symbol character data D_5 to host computer system 6, via the data transmission lines of flexible scanner connector cable 5.

In order to select either the long or short-range mode of object (and bar code range detection), the hand-supportable bar code reading device is provided with both manual and automated mechanisms for effectuating such range selections. For example, a manual switch 27 is mounted on the top surface of the handle portion of the housing, so that long and short-range modes of object and bar code range detection can be selected by simply depressing this switch with ones thumb while handling the bar code reading device. This switch provides control activation signal $A_4=1$ to the system controller, which in turn generates the appropriate mode enable signal E_{IR} .

In the illustrated embodiment, magnetic field sensing circuit 26 is operably associated with the system controller

16

to automatically generate control activation signal $A_4=1$ when the hand-supportable bar code reading device is not supported within scanner support stand 3. As will be described in greater detail hereinafter, scanner support stand 3 includes a means for producing a magnetic field in proximity with either one of the head or handle portion support structures 12A and 12B. With this arrangement, magnetic field sensing circuit 26 generates control activation signal $A_4=1$ when the magnetic field is sensed while the hand-supportable bar code reading device is received within the scanner support stand. Additionally, an indicator light can be provided on the housing of the hand-supportable device to visually indicate the particular mode which has been manually or automatically selected.

In general, magnetic sensing circuit 26 comprises a magnetic flux detector 60, a preamplifier and a threshold detection circuit. Magnetic flux detector 60 produces as output an electrical signal representative of the intensity of detected magnetic flux density in its proximity. When housing 9 is received and supported in scanner support stand 3, as shown, for example, in FIGS. 1, 13, 15, and 17, magnetic flux detector 60 is in position to detect magnetic flux emanating from a magnetic bar fixedly mounted within the handle portion support structure of the scanner support stand. The produced electrical signal from the magnetic flux detector is amplified by the preamplifier whose output is compared to a predetermined threshold maintained in the threshold detector circuit. If the intensity of the detected magnetic flux exceeds the threshold, long-range control activation signal $A_4=1$ is provided to the system controller.

As illustrated in FIG. 2, magnetic flux detector 60 is mounted to the rearward underside surface of the handle portion of housing 9 in the illustrated embodiment, a ferrous bar 61 is interiorly mounted to the underside surface of the housing handle portion as shown. As will be described in greater detail hereinafter, this arrangement facilitates releasable magnetic attachment of the hand-supportable housing to the magnetic bar fixedly installed in the handle portion support structure of the scanner support stand. Preferably, a hole 61A is drilled through ferrous bar 61 to permit installation of magnetic flux detector 60 so that magnetic flux emanating from the handle portion support structure is detectable when the hand-supportable housing is placed within the scanner support stand, as shown in FIGS. 1, 13, 15, and 17. In this configuration, magnetic flux detector 60 is in proximity with the source of magnetic flux (i.e. magnetic bar in the scanner support stand) and thus long-range control activation signal $A_4=1$ is provided to the system controller. In response, the system controller enables long-range object detection (i.e. $E_{IR}=0$). When the hand-supportable housing is removed from the scanner support stand as shown in FIGS. 2, 11C, 14B and 16B, the intensity of the magnetic flux from the scanner support stand is no longer sufficient in strength to produce long-range mode activation signal $A_4=1$; instead, short-range control activation signal $A_4=0$ is provided to the system controller. In response, the system controller enables short-range object detection (i.e. $E_{IR}=1$), and the automatic hand-supportable bar code reading device emulates the operational range of a CCD scanner.

As illustrated in FIG. 2A, a thin ferrous plate 62 is exteriorly applied to the underside of the head portion of the hand-supportable housing. As will be described in greater detail hereinafter, the function of ferrous elements 61 and 62 is to provide a means by which the plastic hand-supportable housing can be magnetically attracted by magnetic elements installed within head and handle portion support structures

5,925,870

17

12B and 12C when the bar code reading device is placed in the scanner support stand.

It is understood that there are a variety of ways in which to configure the above described system components within the hand-supportable housing of the automatic bar code reading device, while successfully carrying out of functions of the present invention. In FIGS. 2A through 2D, one preferred arrangement is illustrated.

In FIG. 2B, the optical arrangement of the system components is shown. Specifically, visible laser diode 50 is mounted in the rear corner of circuit board 63 installed within the head portion of the housing. Stationary concave mirror 55 is mounted centrally at the front end of circuit board 63, primarily for the purpose of collecting laser light reflected off detected objects. Notably, the height of concave mirror 55 is such as not to block transmission aperture 13. Mounted off center onto the surface of concave mirror 55, is a very small second mirror 64 for directing the laser beam to planar mirror 52 which is connected to the motor shaft of scanning motor 53, for joint oscillatory movement therewith. As shown, scanning motor 53 is mounted centrally at the rear end of circuit board 63. In the opposite rear corner of circuit board 63, photodetector 56 and frequency selective filter 57 are mounted.

In operation, laser diode 50 adjacent the rear of the head portion, produces a laser beam which is directed in a forward direction to the small stationary mirror 64 and is then reflected back to oscillating mirror 52. Oscillating mirror 52 directs the laser beam through transmission aperture 13 and light transmissive window 10, while repeatedly scanning the laser beam across the scan field. Under the control of the user, the visible laser beam is aligned with a bar code symbol on the detected object, so that the laser beam scans the bar and space pattern thereof. A portion of the scattered laser light reflected from the bar code symbol is directed back through the light transmissive window and towards oscillating mirror 52, which also acts as a light retroreflective mirror. Oscillating mirror 52 then directs the reflected laser light to stationary concave collecting mirror 55 at the forward end of the head portion of the handsupportable housing. The laser light collected from the concave mirror 55 is then directed to photodetector 56 to produce an electrical signal representative of the detected intensity of the laser light reflected off the bar code symbol.

As illustrated in FIGS. 2C and 2D, IR LED 34 and photodiode 37 are mounted to circuit board 63, in front of stationary concave mirror 55 and in a slightly offset manner from longitudinal axis 15 of the head portion of the housing. Apertures 65A and 65B are formed in opaque housing panel 14B, below transmission aperture 13, to permit transmission and reception of pulsed IR energy signals, as hereinbefore described. In order to shield IR radiation from impinging on photodiode 37 via the housing, a metallic optical tube 66 having an aperture 67 encases photodiode 37. The dimensions of aperture 67, the placement of IR LED 34 and its radiation transmission characteristics collectively will determine the radiation pattern of the transmitted IR signal from aperture 65A in the housing. In order to collect pulsed IR radiation from the object detection field of designed geometry, photodiode 37 is located at a selected distance behind aperture stop 65B formed in opaque housing panel 14B, as shown in FIG. 2D. By selecting the dimensions of aperture stop 65B and the placement of photodiode 37 (and integrally formed lens 36) behind aperture stop 65B, the desired geometrical characteristics and the object detection field can be directly determined, as described hereinbefore.

In order to prevent optical radiation slightly below 670 nanometers from passing through transmission aperture 13

18

and entering the housing, light transmissive window 10 is realized as a plastic filter lens 10 is installed over the transmission aperture. This plastic filter lens has optical characteristics which transmit only optical radiation from slightly below 670 nanometers. In this way, the combination of plastic filter lens 10 at the transmission aperture and frequency selective filter 57 before photoreceiver 56 cooperate to form a narrow band-pass optical filter having a center frequency $f_c = 670$ nanometers. By permitting only optical radiation associated with the visible laser beam to enter the housing, this optical arrangement provides improved signal-to-noise ratio for detected scan data signals D_1 .

In addition to the above-described optical and electro-optical components, circuit board 63 carries all other electronic components and associated circuitry used in realizing IR object detection circuit 16A, scanning mechanism 17, photoreceiving circuit 18, and A/D conversion 19. With respect to the other system components, a second circuit board 69 is mounted within the handle portion of the housing, as shown in FIGS. 2A and 2B. The function of circuit board 69 is to carry electronic components and associated circuitry used in realizing bar code presence detection module 20, bar code scan range detection module 21, symbol decoding module 22, data format conversion module 23, data storage unit 24, data transmission circuit 25, magnetic field detection circuit 26, manual range/mode selection switch 27, and system controller 28. All conductors associated with flexible multiwire scanner cable 5 are electrically connected to circuit board 69 in a manner well known in the art. Electrical communication between circuit boards 63 and 69 is realized using a plurality of electrical wires jumping across these circuit boards.

Having described the detailed structure and internal functions of the automatic bar code reading device of the illustrative embodiment, the operation of its system controller will now be described with reference to system block diagram shown in FIG. 4, the intensity versus time characteristic shown in FIG. 6, and Blocks A to CC shown in FIGS. 7A and 7B.

Beginning at the START block of Main System Control Routine of FIG. 7A and proceeding to Block A, bar code reading device 2 is initialized. This involves continuously activating (i.e. enabling) IR sensing circuit 16A and the system controller. The system controller, on the other hand, deactivates (i.e. disables) the remainder of activatable system components, e.g. laser diode 50, scanning motor 53, photoreceiving circuit 18, A/D conversion circuit 15, bar code presence detection module 20, bar code scan data range detection module 21, symbol decoding module 22, data format conversion module 23, data storage unit 24, and data transmission circuit 25. All timers T_1 , T_2 and T_3 (not shown) are maintained by the system controller, and as indicated, are reset to $t=0$ seconds.

Proceeding to Block B, the system controller checks to determine whether control activation signal $A_1=1$ is received from IR sensing circuit 16A. If this signal is not received, then the system controller returns to the START Block. If signal $A_1=1$ is received, indicative that an object has been detected within the object detection field, then the system controller proceeds to Block C, at which (i) timer T_1 is started and is permitted to run for a preset time period, e.g. $0 \leq T_1 \leq 90$ seconds, (ii) timer T_2 is started and permitted to run for a preset time period $0 \leq T_2 \leq 0.5$ seconds, and (iii) timer T_3 is started and permitted to run for a preset time period (e.g. $0 < T_3 < 0.75$ seconds). Notably, timers T_1 , T_2 and T_3 may be implemented in a variety of ways well known in the art.

5,925,870

19

Proceeding to Block D, the system controller activates laser diode 50, scanning motor 53, photoreceiving circuit 18, A/D conversion circuit 19 and bar code presence detection module 20 in order to collect and analyze scan data signals D_2 for the purpose of determining whether or not a bar code is within the scan field. Then, at Block E, the system controller checks to determine whether control activation signal $A_2=1$ is received from bar code presence detection module 20 within time period $0 \leq T_2 \leq 0.5$ seconds. If activation control signal $A_2=1$ is not received within this time period, indicative that a bar code is not present in the scan field, then the system controller proceeds to Block F. At Block F, the system controller deactivates laser diode 50, scanning motor 53, photoreceiving circuit 18, A/D conversion circuit 19 and bar code presence detection module 20 for a predetermined time period $T_{Laseroff}$ (e.g. 0.5 seconds). Then the system controller proceeds to Block G to determine whether the elapsed time on timer T_1 is greater than 90 seconds. If not, then the system controller proceeds to Block H, at which the system controller determines whether it receives control activation signal $A_1=0$ from IR sensing circuit 16A, indicative that the object is no longer in the object detection field. If this condition exists, the system controller returns to the START Block. If, however, the system controller receives control activation signal $A_2=1$ within time period $0 < T_1 \leq 90$ seconds, indicative that a bar code has been detected, then the system controller proceeds to Block I, at which the system controller resets and restarts timers T_2 and T_3 .

Returning to Block D, the system controller reactivates laser diode 40, scanning motor 53, photoreceiving circuit 18, and A/D conversion circuit 19, and the bar code symbol presence detection module 20. At this stage, fresh bar code scan data is collected and subjected to bar code presence detection data processing. At essentially the same time, the system controller determines at Block F whether control activation signal $A_2=1$ is received from the bar code presence detection module 20 within $T_2=0.5$ seconds, indicative that a bar code has been detected within the allotted time period. If control activation signal A_2 is not received within the time period $0 \leq T_2 \leq 0.5$ seconds, the system controller proceeds to Block F to deactivate laser diode 50, scanning motor 53, photoreceiving circuit 18, A/D conversion circuit 19, and bar code presence detection module 20.

At Block G, the system controller checks to determine whether the elapsed time on timer T_1 is greater than 90 seconds. If at Block H control activation signal $A_1=1$, indicative that an object is still present in the object detection field, the system controller then resets and restarts timers T_2 and T_3 at control Block I, and returns to control Block D, repeating the operations specified in the control loop defined by Blocks D, E, F, G, H, I, D. So long as the object appears within the object detection field and the elapsed time on timer T_1 has not exceeded 90 seconds, the operation of the system controller will be governed by this control loop and the system will remain in the bar code symbol presence detection state. While in this control loop, which can last up to 90 seconds in the illustrative embodiment, the visible laser beam emitted from visible laser diode 50 comprises a plane of pulsed laser light which "flickers" or "blinks" at a flicker sensitivity rate $R_{FLICKER}$ equal to $1/T_{flicker}$ where $T_{flicker}$ equals $T_2 + T_{Laseroff}$. T_2 equals the time length of timer T_2 , and $T_{Laseroff}$ equals the time period that laser diode 50 is intermittently deenergized during the elapsed time period of timer T_1 .

During bar code presence detection state (e.g. $0 \leq T_3 \leq 90$), the flickering nature of the laser scanning beam significantly

20

improves the user's visual perceptibility thereof as it is scanned across the detected object while the user attempts to visually register (i.e. align) the laser beam with the bars and spaces of a bar code symbol on the detected object. The improvement in the visual perceptibility of the flickering laser scanning beam is manifested by the fact that the flickering laser scanning beam is more visually conspicuous than a like laser beam of constant luminosity or intensity. This psychophysiological phenomenon is due to the low frequency pulsed nature of the laser scanning beam. While it is understood in the ophthalmological art that the human visual system is more sensitive to light flickering below about 16 Hz than light of constant luminosity (i.e. intensity), no one in the bar code symbol scanning art has ever recognized or appreciated that this principle could be utilized to solve the visual perceptibility problem occurring in automatic hand-held laser bar code symbol scanners.

The present invention solves the laser scanning beam perceptibility problem in a highly effective manner by applying the principle of "psychophysiological flicker sensitivity" to the construction of the automatic laser bar code symbol scanner of the present invention. Specifically, by causing the intensity of the visible laser scanning beam to flicker at a rate $R_{flicker}$ greater than about 0.10 Hz and less than about 16 Hz, the visual conspicuousness of the laser scanning beam can be significantly improved, while advantageously decreasing the output power of laser diode 50. In any particular embodiment of the present invention, the flicker frequency of the visible laser scanning beam can be selected using the following procedure. First, a value will be selected for time period T_2 which provides sufficient time for the bar code symbol reader to capture multiple lines of scan data from the bar code symbol. This selection will depend on the scanning velocity of the laser beam, the collection optics and data processing considerations. Then, for any selected value of T_2 , the laser-off time period $T_{Laseroff}$ can be selected so that a desired value of $R_{flicker}$ within the range of about 0.1 to about 16 Hz, is obtained. Then by setting parameters T_2 and $T_{Laseroff}$ in the system controller, the desired flicker frequency will automatically be set within the automatic bar code symbol scanner.

When at Block G, the system controller determines that the elapsed time on timer T_1 exceeds 90 seconds, it proceeds to Block J, at which it remains until control activation signal A_1 equals 0, indicative that the object no longer resides within the object detection field. While the system controller resides at Block J, laser diode 50 and scanning motor 53 are deactivated, thus conserving electrical power. The system controller will reside at Block J when placed upon a countertop surface for more than 90 seconds or when an object remains in the scan field for more than 90 seconds. If at Block J control activation signal A_1 does not equal 1 (i.e. $A_1=0$), indicative that the object no longer resides in the object detection field, then the system controller returns to Block A and thereafter remains in the control loop defined by Blocks A, B, A until the same or another object appears in the object detection field. This return to Block A will occur when the hand-supportable bar code symbol reading device is placed within support stand 3 for a time period longer than $T_3=90$ seconds, or when held in space without an object in its object detection field for more than 90 seconds. Then, when the same or another object is brought into the object detection field (while in the stand or during hands-on operation), the system controller will leave the control loop defined by Blocks A, B, A.

At that time, the pulsed laser scanning beam will be again produced while the system controller proceeds through the

5,925,870

21

control loop defined by Blocks D, E, F, G, H, I, D during the bar code presence detection state of operation.

If at Block E, the system controller receives control activation signal $A_2=1$ within $T_2 < 0.15$ seconds, indicative of a bar code symbol present in the scan field, then system controller proceeds to Block K. At this control Block, the system controller continues activation of laser diode 50, scanning motor 53, photoreceiving circuit 18 and A/D conversion circuit 19, and commences the activation of symbol decoding module 22. As will be described hereinafter, movement from control Block E to Block K represents a transition from the bar code presence detection state to the bar code symbol reading state. At Block L, the system controller then determines whether it receives control activation signal $A_3=1$, indicative that a bar code symbol has been decoded within $T_3 \leq 0.75$ seconds. If not, then the system controller returns to Block F, at which laser diode 50, scanning motor 53, and other activatable components are deactivated as previously described.

If at Block L, the system controller determines that control activation signal $A_3=1$ is received from signal decoding module 22 within time period $0 \leq 0.75$ seconds, indicative that the detected bar code symbol has been decoded, it then proceeds to Block M. At this control Block, the system controller determines whether the decoded bar code symbol is different from the previously decoded bar code symbol. If it is different, then the system controller proceeds to Block N, as illustrated. At this Block, the system controller continues activation of laser diode 50, scanning motor 53, photoreceiving circuit 18, and A/D conversion circuit 23, and commences activation of data format conversion module 23, data storage unit 24 and data transmission unit 25. In effect, the user is given a full $T_1=90$ seconds to detect and decode one or more different bar code symbols on a single object without having to remove the object from the object detection field. If, however, the decoded bar code symbol is not different than the previously decoded bar code symbol, then at Block D the system controller checks to determine whether timer T_3 has lapsed (i.e. $T_3 > 0.75$ seconds). If it has not lapsed, the system controller returns and proceeds through the control loop defined by Blocks L, M, P, L, within which the device is permitted to successfully decode a detected bar code symbol in the scan field code symbol within the set time interval $0 \leq T_3 \leq 0.75$ seconds. If, however, timer T_3 lapses, then the system controller proceeds to Block F to reenter the control loop defined by control Blocks D, E, F, G, H, I, D. These operations ensure repeated scanning of the beam across the scan field, while symbol character data is being appropriately formatted and transmitted to host computer system 6 by a conventional data communication process well known in the art. Notably, movement from Block M to N represents a transition from the bar code symbol reading state to symbol character data transmission state.

After transmission of symbol character data to the host device is completed, the system controller reenters (at Block F) the control loop defined by Blocks D, E, F, G, H, I, D. At this stage of the control process, the system controller deactivates laser diode 50, scanning motor 53, photoreceiving circuit 18 and A/D conversion circuit 19 for $T_{Laser\ off} = 0.5$ seconds. This event represents a transition from the bar code reading state to the remaining 90 seconds of the bar code presence detection state. Reentering this control loop represents a transition from the bar code symbol reading state back to the bar code symbol detection state, in which the laser scanning beam flickers in the scan field at the flicker rate $R_{Flicker}$ defined above.

22

The operation of automatic hand-supportable bar code reading device 2 has been described in connection with the Main System Control Routine which uses control activation signals A_1 , A_2 and A_3 . This system control routine operates on two basic assumptions concerning IR sensing circuit 16A and bar code symbol presence detection module 20. Specifically, the Main System Control Routine assumes that the IR sensing circuit produces control activation signal $A_1=1$ whenever an object is detected anywhere within the operative detection range of the object detection field. It also assumes that the bar code symbol presence detection module produces control activation signal $A_2=1$ whenever a bar code symbol is detected anywhere within the operative scanning range of the scan field. These assumptions cause state transitions during the operation of the automatic bar code symbol reading device, when otherwise they may not be desired in particular applications.

For example, in some applications it may not be desirable to automatically advance the bar code symbol reading device to its bar code presence detection state until an object bearing a bar code is within the short-range portion of the object detection field, as hereinbefore described. Also, it may not be desirable to automatically advance to the bar code symbol reading state until a detected bar code symbol is located within the short-range portion of the scan field. Also, it may not be desirable to automatically advance to the symbol character data storage/transmission state until a decoded bar code symbol is located within the short-range portion of the scan field. Thus, in some instances, it may be desirable to condition transition from (i) object detection to the bar code symbol detection state, (ii) the bar code symbol detection state to the bar code symbol reading state, and (iii) the bar code symbol reading state to the symbol character data storage/transmission state. Yet, in other instances, it may only be desirable to condition only one or two of these state transitions.

FIGS. 8A and 8B illustrate the Auxiliary System Control Routine with Range Selection which provides the automatic bar code reading device of the present invention with range selection capabilities for object detection, bar code presence detection, and bar code symbol reading. These range selection functions are provided when the system controller runs the Auxiliary System Control Routine of in cooperation with the Main System Control Routine described above. It is understood, however, that this Auxiliary System Control Routine may be adapted for use with other suitable system control programs.

Beginning at the START block and proceeding to Block A' of FIG. 8A, the system controller initially selects the long-range object detection mode by letting the IR sensing circuit operate at full sensitivity (i.e. $E_{IR} = 0$). To determine whether the short-range mode of object detection, bar code symbol presence detection and bar code symbol reading has been selected, the system controller proceeds to Block B' and checks whether it has received control activation signal $A_4=1$. As described hereinbefore in connection with FIG. 4, activation signal $A_4=1$ can be generated in at least two possible ways. For example, the short-range mode may be manually selected by depressing switch 27 on the handle portion of the housing. Alternatively, the short-range mode may be selected by simply lifting the bar code reading device out from the scanner support stand, as illustrated in FIGS. 2, 11C, 14B, and 16B. In either case, prior to operating the bar code reading device, it is preferred that either the manual or automatic range mode selection mechanism be programmably set within the system controller by way of bar code menu programming, a technique well

5,925,870

23

known in the art. For purposes of illustration only, the Auxiliary System Control Routine of FIGS. 8A and 8B will be described using the automatic range mode selection mechanism provided by magnetic sensing circuit 26.

If control activation signal $A_3=1$ is received at Block H', then the system controller selects short-range object detection by desensitizing the IR sensing circuit. This is achieved by providing mode selection enable signal $E_{IR}=1$ as hereinbefore described. Then proceeding to Block D', the system controller enters the START block of Main System Control Routine of FIGS. 7A and 7B. Thereafter, the control flow proceeds as prescribed by the Main System Control Routine. Notably, whenever the control flow in the Main System Control Routine returns to the START block of FIG. 7A, the system controller exits Main System Control Routine and returns to the START block of FIG. 8A.

As illustrated at Block E' of FIG. 8A, whenever the control flow is at Block D in the Main System Control Routine, the system controller activates bar code presence detection 20 module and bar code scan range detection module 21. Thereafter, while at any one of these control blocks, the bar code scan range detection module processes scan data signals D_2 so as to produce digital count and sign data as hereinbefore described. As indicated at Block F', an additional condition is placed on control Block E in the Main System Control Routine so that a transition from the bar code presence detection state to the bar code symbol reading state occurs only if (i) the object is detected in the short-range portion of the object detection field, and (ii) the bar code symbol is detected in the short-range portion of the scan field. In terms of data processing, when the system control flow is at any one of such blocks in the Main System Control Routine and the system controller receives control activation signal $A_2=1$, then the system controller also determines whether the digital count data of the detected bar code resides within the short-range count interval.

If the produced digital count data D_{c1} indicates that the detected bar code symbol is located within the short-range portion of the scan field, then as indicated at Block G' of FIG. 8B, the system controller continues activation of the laser diode 50, scanning motor 53, photoreceiving circuit 18 and A/D conversion circuit 19, while commencing activation of symbol decoding circuit 22. As indicated at Block H', whenever the control flow is at either Block I in the Main System Control Routine and the system controller receives third control activation signal $A_{3a}=1$, then the system controller determines whether the digital count data D_{c1} from the decoded bar code symbol resides within the short-range count interval (i.e. $A_{3b}=1$). If digital count data D_{c2} resides within the short-range portion of the scan field (i.e. $A_{3b}=1$), then as indicated at Block I', the system controller proceeds to Block M in the Main System Control Routine. If at Block H' digital count data D_{c1} is not within the short-range portion of the scan field (i.e. $A_{3b}=0$), then as indicated at Block J', the system controller proceeds to Block F' in the Main System Control Routine. If, however, digital count data D_{c1} produced at Block F indicates that the detected bar code symbol is not located within the short-range portion of the scan field (i.e. $A_{2a}=0$), then as indicated at Block K' of FIG. 8A, the system controller proceeds to Block F in the Main System Control Routine.

Turning attention to Block B' of FIG. 8A, the system controller may not receive control activation signal $A_1=1$ from range selection circuits 26 or 27, as indicated at this Block. Instead, short and long-range mode capabilities can be automatically selected by reading bar code symbols. This can be achieved by programming symbol decoding module

24

22 to recognize predesignated bar code symbols which automatically activate and deactivate long-range and short-range modes of object detection, bar code presence detection, and/or bar code symbol reading. This mechanism for automatic range selection is highly advantageous in many applications, such as, for example, reading bar code menus, CCD scanner emulation and the like.

As indicated at Block B' in FIG. 8A, when control activation signal $A_1=1$, the system controller activates the long-range mode of object detection by letting IR sensing circuit 16A operate at full sensitivity (i.e. $E_{IR}=0$), as indicated at Block L'. Then at Block M', the system controller enters the START block of Main System Control Routine of FIGS. 7A and 7B. As indicated at Block N', before entering Block N of the Main System Control Routine, the system controller determines whether the successfully read bar code symbol is a bar code symbol which has been predesignated to activate the short-range mode of object detection, bar code presence detection and/or bar code symbol reading. This condition is determined by the system controller checking whether control activation signal $A_3=1$ is received from the symbol decoding module shown in FIG. 4. If control activation signal $A_3=0$ is received by the system controller, then as indicated at Block O', the system controller proceeds to Block N of the Main System Control Routine. If, however, control activation signal $A_3=1$ is received, then as indicated at Block P', the system controller activates the short-range mode of object detection by desensitizing IR sensing circuit 16A (i.e. $E_{IR}=0$). This operation ensures that control activation signal A_1 is produced only when an object is detected within the short-range portion of the object detection field. As indicated at Block Q' of FIG. 8A, whenever the system controller is at Block D in the Main System Control Routine, the system controller activates bar code presence detection module 20 and bar code scan range detection module 21.

As indicated at Block R', an additional condition is placed on control Block E in the Main System Control Routine. Specifically, a transition from the bar code presence detection state to the bar code symbol reading state occurs only if the detected bar code symbol resides in the short-range portion of the scan field. This condition is satisfied by the scan range detection module determining whether or not the digital count data of the detected bar code symbol falls within a prespecified short-range count interval. If this digital count data does not fall within the short-range count interval, then as indicated at Block R', the system controller proceeds to control Block F in the Main System Control Routine, as indicated at Block K'. If, however, the digital count data is within the prespecified short-range count interval, then control activation signal $A_{2a}=1$ is provided to the system controller as illustrated in FIG. 4. In this instance, both control activation signals $A_{2a}=1$ and $A_{2b}=1$ are provided to the system controller so as to effectuate a transition to the bar code symbol reading state. This event is represented at Block G' of FIG. 8B by the system controller continuing the activation of laser diode 50, scanning motor 53, photoreceiving circuit 18, A/D conversion circuit 19 and bar code scan range detection module 20, while deactivating bar code symbol detection module 21 and activating symbol decoding module 22.

As indicated at Block H' of FIG. 8B, when the control flow is at Block I in the Main System Control Routine and the system controller receives control activation signal $A_{3a}=1$, then the system controller determines whether the digital count data of the decoded bar code symbol is within the short-range count interval. If the bar code scan range detec-

5,925,870

25

tion module determines that decoded bar code symbol resides within the prespecified short-range portion of the scan field, then it provides third control activation signal $A_{3D}=1$ to the system controller, causing the bar code reading device to undergo a transition to the symbol character data transmission/storage state. In this case, as indicated at Block U', before entering Block N in the Main System Control Routine, the symbol decoding module determines whether the decoded bar code symbol is a short-range mode deactivation symbol. If the decoded bar code is such a symbol, then as indicated at Block V', the system controller activates the long-range mode by letting IR sensing circuit 16A operate at full sensitivity (i.e. $E_{IR}=0$), while deactivating bar code scan range detection module 21. Thereafter, the system controller proceeds to Block F in the Main System Control Routine as indicated at Block W. If, however, the decoded bar code symbol is not a short-range mode deactivation symbol, then as indicated at Block U', the system controller proceeds directly to Block N in the Main System Control Routine, as indicated at Block X. If, however, as indicated at Block T' the decoded bar code symbol does not reside within the short-range portion of the scan field, the system proceeds to Block F1.

Having described the operation of the illustrative embodiment of the automatic hand-supportable bar code reading device of the present invention, it will be helpful to describe at this juncture the various conditions which cause state transitions to occur during its operation. In this regard, reference is made to FIG. 9 which provides a state transition diagram for the illustrative embodiment.

As illustrated in FIG. 9, the automatic hand-supportable bar code reading device of the present invention has four basic states of operation namely: object detection, bar code symbol presence detection, bar code symbol reading, and symbol character data transmission/storage. The nature of each of these states has been described above in great detail. These four states are schematically illustrated as A, B, C and D, respectively, in the state transition diagram of FIG. 9.

As shown in FIG. 9, transitions between the various states are indicated by directional arrows. Besides each set of directional arrows are transition conditions expressed in terms of control activation signals (e.g. A_1 , A_2 and A_3 , and where appropriate, state time intervals (e.g. T_1 , T_2 , and T_3). Conveniently, the state diagram of FIG. 9 expresses most simply the four basic operations occurring during the control flow within the system control program of FIGS. 7A and 7B. Significantly, the control activation signals A_1 , A_2 and A_3 in FIG. 9 indicate which events within the object detection and/or scan fields can operate to effect a state transition within the allotted time frame(s), where proscribed.

Referring now to FIGS. 10 through 10B, the scanner support stand of the present invention will be described.

As illustrated in FIGS. 10 through 10B, scanner stand 3 of the illustrative embodiment comprises support frame 12 releasably connected to a base support/mounting plate 70 by way of a snap fit fastening mechanism illustrated in FIG. 13C. In the illustrative embodiment, support frame 12 is formed as an injection molded shell, in which handle portion support structure 12B is realized by a first support recess 71; whereas head portion support structure 12C is realized by a second support recess 72. As shown in FIG. 10, first support recess 71 is disposed above base portion 12A and inclined at a first acute angle B_1 with respect thereto, while second support recess 72 is disposed above base portion 12B and inclined at a second acute angle B_2 with respect thereto.

As best shown in FIG. 10, first support recess 72 is formed by a first substantially planar support surface 73 surrounded

26

by the projection of opposing side walls 74A and 74B and rear wall 74C, extending above planar support surface 73 in a perpendicular fashion. The function of support recess 71 is to receive and support the handle portion of hand-supportable bar code reading device. Similarly, second support recess 72 is formed by a second substantially planar support surface 75 surrounded by the projection of opposing side walls 76A and 76B and front wall surface 76C extending above planar support surface 75 in a perpendicular fashion.

The function of support recess 72 is to receive and support the head portion of hand-supportable bar code reading device 2. In order that the handle portion of hand-supportable bar code reading device 2 can be received within support recess 71, rear wall 74C has a scanner cable aperture 77 which permits flexible scanner cable 5 to extend freely out beyond support recess 71. Also, front wall projection 76C is slightly lower than side wall projection 76A and 76B to ensure that pulsed IR energy is freely transmitted from and received by object detection circuit 16A contained within head portion 9A. At the same time, this structural feature of the scanner support stand ensures that visible laser light is projected, scanned and collected through light transmissive window 10 without obstruction, i.e. when the automatic bar code reading device is operated in its automatic hands-free mode, shown in FIGS. 15 and 17.

In order to ensure that the hand-supportable bar code reading device of the present invention will be securely, yet releasably supported within support recesses 71 and 72 and not easily knocked out of the scanner support stand during the hands-free mode of operation, first and second magnetic elements 77 and 78 are permanently mounted to the underside of planar support surfaces 73 and 75, respectively, as illustrated in FIG. 10B. With this arrangement, magnetic flux of constant intensity continuously emanates from support recesses 71 and 72. As a result, when the handle and head portions of the bar code reading device are placed within support recesses 71 and 72, ferrous element 61 in handle portion 9A is magnetically attracted to magnetic element 77, while ferrous element 62 on head portion 9B is magnetically attracted to magnetic element 78. The magnetic force of attraction between these elements is selected so that a desired degree of force is required to lift the automatic bar code reading device out of scanner support stand, while preventing accidental displacement of the device from the scanner support stand during use in the hands-free mode of operation.

As illustrated in FIG. 10A, base support/mounting plate 70 is formed as a thin planar structure having perimetrical dimensions substantially equal to the perimetrical dimensions of the base portion of support frame 12. At the front and rear end portions 70A and 70B of base plate 70, a pair of projections 79 and 80 extend perpendicularly, as shown. Projections 79 and 80 have horizontal flanges 79A and 80A, respectively which are adapted to snap fit into horizontal grooves 81 and 82, formed on the interior surfaces of front and rear walls 76C and 74C, as shown in FIGS. 10A, 10B and 13C.

To facilitate mounting of base plate 70 on a planar mounting surface, as illustrated in FIGS. 12A and 12B, a pair of spaced apart mounting holes 83A and 83B are provided. To facilitate attachment of base plate 70 to pivotal joint assembly 97 of pedestal base 98, as illustrated in FIGS. 18A through 18C, a set of four centrally disposed mounting holes 84A, 84B, 84C and 84D are provided. To facilitate support of base plate 70 upon a horizontal support surface, as illustrated in FIGS. 11A through 11D, a set of four rubber

5,925,870

27

feet 85A, 85B, 85C and 85D may be adhesively applied to the underside corners of the base plate 70.

In order to eliminate the confusion produced by various cables used to connect automatic bar code scanning device 2 to its external power supply (not shown) and associated host computer system 6, an adapter module 86 is concealed within the interior volume 87 contained between the interior surface of base portion 12A of the support frame and the upper surface of base plate 70. In the illustrated embodiment, adapter module 86 is adhesively affixed to the central portion of the upper surface of base plate 70, as illustrated in FIG. 10A. Scanner connector 31 of flexible scanner cable 5 is plugged into scanner jack 86A of the adapter module, and the communication cable connector of flexible communication cable 7 is plugged into communication jack 86B. Similarly, the power supply connector from the DC power supply cable 8 is plugged into power supply jack 86C, as shown. With these interconnections established, support frame 12 is snapped onto base plate 70, as hereinbefore described, flexible scanner cable 5 is routed through aperture 87, and flexible communication and power supply cables 7 and 8 are routed through aperture 88 formed in the lower portion of rear wall 74C of the support frame, as shown in FIG. 10.

In the illustrative embodiment, automatic bar code reading device 2 requires one regulated DC supply voltage to power the visible laser diode and other electronic and opto-electronic components mounted on circuit boards 63 and 69. However, in many applications, a 12V DC supply voltage is available at the point-of-sale station. Thus, in order to convert the 12V DC supply voltage to a 5V DC supply voltage, a DC-to-DC voltage converter is incorporated into adapter module 86. In this way, in addition to providing interconnections between the communication lines of the flexible scanner and communication cables, adapter module 86 also provides a means for converting the voltage level of the flexible power supply cable to one or more required voltages to be utilized in the bar code reading device. The automatic bar code reading device of the present invention has been described in great detail. Thus, it is appropriate at this juncture to illustrate the automatic hands-on and hands free modes of operation of the system while utilized in different mounting installations.

In FIGS. 11A through 11D, a point-of-sale station is shown comprising an electronic cash register 6 operably connected to the automatic bar code reading system of the present invention by way of flexible communication cable 7. Low voltage DC power is provided to the system by way of flexible power supply cable 8. In this particular mounting installation, scanner support stand 3 includes rubber feet 85A through 85D and is supported on a horizontal counter-top surface 90. If necessary or desired in such mounting installations, base plate 70 may be weighted by affixing one or more dense mass elements to the upper surface of the base plate.

With automatic bar code reading device 2 supported within scanner support stand 3 as shown in FIG. 11A, the system is automatically induced into its automatic long-range hands-free mode of operation. However, owing to the positioning of both object detection and scan fields in this mounting installation, only bar code symbols located on small, very low profile objects can be easily read. In order to induce the system into its short-range hands-on mode of operation, the user simply encircles the handle portion of the handsupportable device with his or her fingers, and then lifts the device out of the scanner support stand, as shown in FIG. 11B. With the automatic bar code reading device held in the

28

user's hand, and a bar coded object 91 in the other hand, the object is moved into the short-range portion of the object detection field as shown in FIG. 11C, where the object is automatically detected and bar code symbol 92 automatically scanned by the visible laser beam repeatedly scanned across the scan field. After the bar code symbol has been successfully read and an audible and/or visible indication thereof produced by successful read indicator 120, the bar code reading device is placed back within the scanner support stand, as shown in FIG. 11A, where it is once again induced into its long-range hands-free mode of operation.

In FIGS. 12A and 12B, the scanner support stand of the present invention is shown being installed on a vertical counter wall surface of a point-of-sale station having an electronic cash register 6. As shown in FIGS. 12A and 12B, to install the scanner support stand, a pair of spaced apart mounting screws 94A and 94B are partially screwed into vertical counter wall surface 93 so that base plate 70 will be vertically arranged slightly below horizontal countertop surface 95. Then, mounting holes 83A and 83B and screws 94A and 94B are passed through base plate 70, and then the base plate is slid down slightly and screws 94A and 94B completely threaded into the vertical counter wall surface. After attaching adaptor module 86 and flexible scanner, communication and power supply cables 5, 7, and 8 into their respective jacks in the adaptor module, support frame 12 is snap fitted over the mounted base plate, as shown in FIG. 12B, to provide an installed automatic bar code reading system, as shown in FIG. 13.

With automatic bar code reading device 2 positioned within scanner stand 3 as shown in FIG. 14, the system is automatically induced into its long-range hands-free mode of operation. In this configuration, bar code symbol 92 on object 91 can be easily read by the user grasping the object and bringing it into the short-range portion of the object detection field, as illustrated in FIG. 14. Thereupon, the object is automatically detected and bar code symbol 92 scanned by the visible laser beam repeatedly scanned across the scan field.

In order to read bar code symbols in the short-range hands-on mode of operation, the user grasps the handle portion of the bar code reading device as illustrated in FIG. 15A, and lifts it out of the scanner support stand. Then the user brings object 91 into the short-range portion of the object detection field as illustrated in FIG. 15B, so as to automatically detect the object and scan bar code symbol 92 with the visible laser beam repeatedly moving across the scan field. After the bar code symbol has been successfully read and an audible and/or visible indication thereof produced, the bar code reading device is placed back into the scanner support stand, automatically inducing the system into its long-range hands-free mode of operation.

In FIGS. 16 through 17B, a point-of-sale station is shown comprising the automatic bar code reading system of the present invention operably connected to electronic cash register 6 by way of flexible communication and power supply cables 7 and 8. In this particular mounting installation, scanner support stand 3 is pivotally supported above a horizontal counter surface 96 by way of a pivotal joint assembly 97 connected to pedestal base 98 mounted under the electronic cash register, as illustrated in FIGS. 18 and 18C.

As more clearly illustrated in FIG. 18, pivotal joint assembly 97 comprises a ball structure 99 joined to a mounting plate 100 by an extension 101. The pivotal joint assembly 97 also comprises a semispherical recess 102

5,925,870

29

formed in the end of a cylindrical support post 103. As shown in FIG. 18A, a ball clamping element 104, having a semispherical recess 105 and a bore 106, is connected to the distal end portion of support post 103 by an adjustment screw 107 passing through bore 106 and threaded into a hole 108 in the distal end portion of the support post. By rotating knob 109 attached to adjustment screw 107, aligned semi-spherical recesses 102 and 105 can be sufficiently separated apart to receive and retain ball structure 99. With this structural arrangement, ball structure 99 can be securely clasped within semispherical recesses 102 and 105 at any desired orientation by simply tightening adjustment screw 107 with several turns of knob 109. As illustrated in FIG. 18A, mounting plate 100 is fixedly connected to base plate 70 by bolts 110A through 110D threaded through holes 111A through 111D and 84A through 84D, respectively.

As illustrated in FIG. 18, the proximal end of support post 103 is fixedly connected to the upper portion of pedestal base member 98A, by screw 112. In order to maintain the scanner support stand stationary during bar code reading operations, pedestal base member 98B is mounted under electronic cash register 6. When installed in the manner illustrated, scanner support stand 3 can be adjustably positioned and locked into virtually any orientation in three-dimensional space, owing to the three principle degrees of freedom provided by the pivotal joint assembly. In FIGS. 16A, 18, 18B and 18C, these degrees of freedom are illustrated with respect to the cartesian coordinate system shown embedded within the pivotal joint assembly of the pedestal-mounted scanner support stand.

With automatic bar code reading device positioned within scanner stand 3 as shown in FIG. 16, the system is automatically induced into its long-range hands-free mode of operation. By simply moving object 91 into the object detection field, the bar code symbol 92 is repeatedly scanned by the visible laser beam scanned across the scan field. To induce the automatic bar code reading system into its short-range hands-on mode of operation, the user simply grasps the automatic bar code reading device and lifts it out of the scanner support stand, as illustrated in FIG. 17A. Then, by placing object 91 into the short-range portion of the object detection field, the object is automatically detected and bar code symbol 92 scanned by the visible laser beam repeatedly scanned across the scan field. After the bar code symbol has been successfully read and an audible and/or visible indication thereof produced, the automatic bar code reading device can be placed back into the scanner support stand, automatically inducing the system into its long-range hands-free mode of operation.

Having described the preferred embodiment of the present invention, several modifications come to mind.

For example, in alternative embodiments of the present invention, the automatic hand-supportable device may not incorporate within its housing, electronic circuitry for carrying out control, decoding other data processing functions; instead such electronic circuitry may be contained within a remote unit operably associated with the hand supportable device by way of the flexible scanner cable. In this embodiment, the hand-supportable device will function as an automatic hand-supportable laser scanner. Alternatively, the housing may be adapted for hand-mounting.

The automatic bar code reading device and scanner support stand of the present invention provides a fully automatic bar code reading system characterized by a automatic long-range hands-free and short-range hands-on mode of operation, highspeed symbol recognition, and versatility.

30

The automatic hand-supportable bar code reading device of the present invention has been provided with a wide variety of complex decision-making operations, endowing the system with a level of intelligence hitherto unattained in the bar code symbol reading art. Within the spirit of the present invention, additional decision-making operations may be provided to further enhance the capabilities of the system.

While the particular illustrative embodiments shown and described above will be useful in many applications in code symbol reading, further modifications to the present invention herein disclosed will occur to persons skilled in the art. All such modifications are deemed to be within the scope and spirit of the present invention defined by the appended claims.

What is claimed is:

1. A bar code symbol reading system having a bar code symbol detection mode of operation and a bar code symbol reading mode of operation, said bar code symbol reading system comprising:

a housing having a light transmission aperture through which visible light can exit and enter said housing; system activation means disposed in said housing for producing an activation signal indicative of an object located within at least a portion of a scan field definable external to said housing;

a laser beam source in said housing for producing a visible laser beam within said housing;

laser beam directing means in said housing, for directing said visible laser beam through said light transmission aperture and into said housing;

a scanning mechanism in said housing for scanning said visible laser beam across said scan field and a bar code symbol on said object in response to production of said activation signal, said scanned visible laser beam flickering in said scan field at a rate in the range from about 0.5 Hz to about 16 Hz so as to improve the visual conspicuousness of said visible laser beam in said scan field during the bar code symbol detection mode of operation;

light detection means in said housing, for detecting the intensity of laser light reflected off said bar code symbol, and for automatically producing scan data indicative of the detected intensity of said reflected laser light;

scan data processing means for processing produced scan data so as to detect and decode said scanned bar code symbol, and upon detecting and decoding said scanned bar code symbol, automatically producing symbol character data representative of said detected and decoded bar code symbol; and

control means for controlling the operation of said bar code symbol reading system.

2. The bar code symbol reading system of claim 1, wherein said bar code symbol has first and second envelope borders, and wherein said scan data processing means comprises

means for detecting said first and second envelope borders of said scanned bar code symbol, and

means for decoding said detected bar code symbol.

3. The bar code symbol reading system of claim 1, wherein said housing comprises a hand-supportable structure supportable within a stand, and said hand-supportable structure has a head portion and a handle portion, and wherein said laser beam source, said laser beam directing

5,925,870

31

means, said scanning mechanism, and said light detection means are disposed in said head portion.

4. The bar code symbol reading system of claim 3, wherein said system activation means comprises an object detector for automatically generating said activation signal in response to the automatic detection of said object in at least a portion of said scan field.

5. The bar code symbol reading system of claim 4, wherein said object detector comprises

a signal transmitting means for transmitting a signal into said scan field, and

a signal receiving means for receiving said transmitted signal reflected off said object in at least a portion of said scan field, and automatically generating said activation signal.

6. The bar code symbol reading system of claim 5, wherein said signal transmitting means comprises an infra-red light source for transmitting a pulsed infra-red light signal, and wherein said signal receiving means comprises an infra-red light detector disposed in said hand-supportable housing for receiving at least a portion of said pulsed infra-red light signal.

7. A method of reading bar code symbols using a laser scanning unit having a bar code detection mode of operation and a bar code symbol reading mode of operation said method comprising the steps;

(a) bringing an object in a non-contacting relationship with said laser scanning unit so that said object is located within at least a portion of a scan field definable external to said laser scanning unit;

(b) generating an activation signal indicative of the presence of said object located in at least a portion of said scan field;

(c) in response to the generation of said activation signal during step (b) and automatically entering said bar code symbol detection mode of operation;

(1) automatically producing from said laser scanning unit, a visible laser beam which (i) is scanned across said scan field and a bar code symbol on said object, and (ii) flickers in said scan field at a rate in the range from about 0.5 Hz to about 16 Hz so as to improve the visual conspicuousness of said visible laser beam in said scan field during said bar code symbol detection mode;

(2) at said laser scanning unit, automatically detecting at said laser scanning unit, the intensity of laser light reflected off said scanned bar code symbol, and automatically producing scan data indicative of the detected intensity of said reflected laser light, and

(3) automatically processing produced scan data in order to detect said scanned bar code symbol on said object;

(d) upon detecting said scanned bar code symbol, automatically entering said bar code symbol reading mode of operation, and continuing to produce scan data indicative of the detected intensity of laser light reflected off said detected bar code symbol, and automatically processing produced scan data in order to decode said detected bar code symbol on said object, and

(e) upon decoding said detected bar code symbol, automatically producing symbol character data representative of said detected and decoded bar code symbol.

8. The method of claim 7, wherein said bar code symbol has first and second envelope borders, and wherein substep (c) (3) comprises detecting said first and second envelope

32

borders of said bar code symbol and decoding said detected bar code symbol.

9. The method of claim 7, wherein step (b) comprises generating said activation signal from an object detection mechanism disposed in said laser scanning unit.

10. A bar code symbol reading system for use by a user endowed with a human vision system having a critical flicker frequency, said bar code symbol reading system having a bar code symbol detection mode of operation and a bar code symbol reading mode of operation, said bar code symbol reading system comprising:

a housing having a light transmission aperture through which visible light can exit and enter said housing;

system activation means in said housing for producing an activation signal indicative of the presence of an object within at least a portion of a scan field definable external to said housing;

laser beam source in said housing for producing a visible laser beam within said housing;

laser beam directing means in said housing, for directing said visible laser beam through said light transmission aperture and into said scan field;

a scanning mechanism in said housing for scanning said visible laser beam across said scan field and a bar code symbol on said object, during said bar code symbol detection mode and said bar code symbol reading mode, said scanned visible laser beam flickering in said scan field during said bar code symbol detection mode, at a rate below the critical flicker frequency of the user's human visual system so as to improve the visual conspicuousness of said visible laser beam in said scan field during said bar code symbol detection mode of operation;

light detection means in said housing, for detecting the intensity of laser light reflected off said scanned bar code symbol, and for automatically producing scan data indicative of the detected intensity of said reflected laser light;

scan data processing means for processing produced scan data during said bar code symbol detection mode and said bar code symbol reading mode, so as to detect and decode said scanned bar code symbol on said detected object, and upon detecting and decoding said scanned bar code symbol, automatically producing symbol character data representative of said detected and decoded bar code symbol; and

control means for controlling the operation of said bar code symbol reading system.

11. The bar code symbol reading system of claim 10, wherein said object detection comprises

a signal transmitting means for transmitting a signal into said scan field, and

a signal receiving means for receiving said transmitted signal reflected off said object in at least a portion of said scan field, and automatically generating said activation signal indicative of the detection of said object in at least a portion of said scan field.

12. The bar code symbol reading system of claim 11, wherein said signal transmitting means comprises an infra-red light source for transmitting a pulsed infra-red light signal, and wherein said signal receiving means comprises an infra-red light detector disposed in said hand-supportable housing for receiving said pulsed infra-red light signal.

13. The automatic bar code symbol reading system of claim 10, wherein said housing comprises a hand-

5,925,870

33

supportable structure supportable in a stand and said hand-supportable structure comprises a head portion and a handle portion, and wherein said laser beam source, said laser beam directing means, said scanning mechanism, and said light detection means are disposed in said head portion. 5

14. A method of reading bar code symbols using a laser scanning unit having a bar code symbol detection mode, said method comprising the steps:

- (a) bringing an object in a non-contacting relationship with said laser scanning unit so that said object is located within at least a portion of a scan field definable external to said laser scanning unit; 10
- (b) generating an activation signal indicative of the presence of said object in at least a portion of said scan field and inducing said laser scanning unit into said bar code symbol detection mode; 15
- (c) in response to the generation of said activation signal during step (b),
 - (1) automatically producing from said laser scanning unit, a visible laser beam which is scanned across

34

said scan field and a bar code symbol on said object, and said scanned visible laser beam flickers in said scan field at a rate less than the critical flicker frequency of a user's human visual system, so as to improve the visual conspicuousness of said visible laser beam in said scan field;

- (2) at said laser scanning unit automatically detecting the intensity of laser light reflected off said bar code symbol, and automatically producing scan data indicative of the detected intensity of said reflected laser light, and
- (3) automatically processing produced scan data in order to detect and decode said scanned bar code symbol; and
- (d) upon detecting and decoding said bar code symbol, automatically producing symbol character data representative of said detected and decoded bar code symbol.

* * * * *

EXHIBIT C



US005939698A

United States Patent [19]
Rockstein et al.

[11] **Patent Number:** **5,939,698**
 [45] **Date of Patent:** ***Aug. 17, 1999**

[54] **BAR CODE SYMBOL READING SYSTEM HAVING AUTOMATIC HAND-SUPPORTABLE BAR CODING SYMBOL READING DEVICE AND STAND FOR SUPPORTING PROJECTED SCAN FIELD THEREOF**

[75] **Inventors:** **George B. Rockstein, Audubon; David M. Wilz, Sr., Sewell; David P. Bubnoski, Glassboro; Carl H. Knowles, Moorestown, all of N.J.**

[73] **Assignee:** **Metrologie Instruments, Inc., Blackwood, N.J.**

[*] **Notice:** This patent is subject to a terminal disclaimer.

[21] **Appl. No.:** **08/979,974**

[22] **Filed:** **Nov. 26, 1997**

Related U.S. Application Data

[63] Continuation of application No. 08/690,677, Jul. 31, 1996, which is a continuation of application No. 08/476,069, Jun. 7, 1995, Pat. No. 5,591,953, which is a continuation of application No. 08/147,833, Nov. 4, 1993, Pat. No. 5,424,525, which is a continuation of application No. 07/583,421, Sep. 17, 1990, Pat. No. 5,260,553.

[51] **Int. Cl.⁶** **G06K 7/10**
 [52] **U.S. Cl.** **235/462; 235/472**
 [58] **Field of Search** **235/462, 463, 235/466, 472, 454, 455**

[56] **References Cited**

U.S. PATENT DOCUMENTS

4,240,064 12/1980 DevChoudbury 235/455 X

4,639,606	1/1987	Boles et al.	235/455 X
4,766,297	8/1988	McMillan	235/455
4,855,581	8/1989	Mertel et al.	235/462
4,933,538	6/1990	Heiman et al.	235/462
5,019,698	5/1991	Eustman	235/462
5,059,777	10/1991	Wittensoldner et al.	235/470
5,086,215	2/1992	Carsner et al.	235/462
5,260,553	11/1993	Rockstein et al.	235/462
5,272,323	12/1993	Martino	235/462
5,424,525	6/1995	Rockstein et al.	235/462
5,591,953	1/1997	Rockstein et al.	235/462

Primary Examiner—Michael G. Lee
Attorney, Agent, or Firm—Hopgood, Calimafde, Kalil & Judlowe, LLP

[57] **ABSTRACT**

Bar code symbol reading system with automatic modes of hand-held (i.e., hands-on) and stand-supported (i.e., hands-free) operation. In the hand-held mode of automatic operation, the user initiates laser scanning by simply bringing the object within at least a portion of the scan field of the automatic bar code symbol reading device. In the stand-supported mode of automatic operation, a scanner support stand is used to support the automatic bar code symbol reading device relative to a countertop surface so that the scan field is projected away from the scanner support stand and the hand-supportable housing, and extends above the countertop surface permitting the automatic reading bar code symbols on goods passed thereby. This way, during the scanner-supported mode of automatic operation, a bar code symbol on an object of virtually any size can be automatically read when the object is automatically detected in the outwardly projected scan field while the hand-supportable bar code symbol reading device is supported within the scanner support stand.

9 Claims, 10 Drawing Sheets

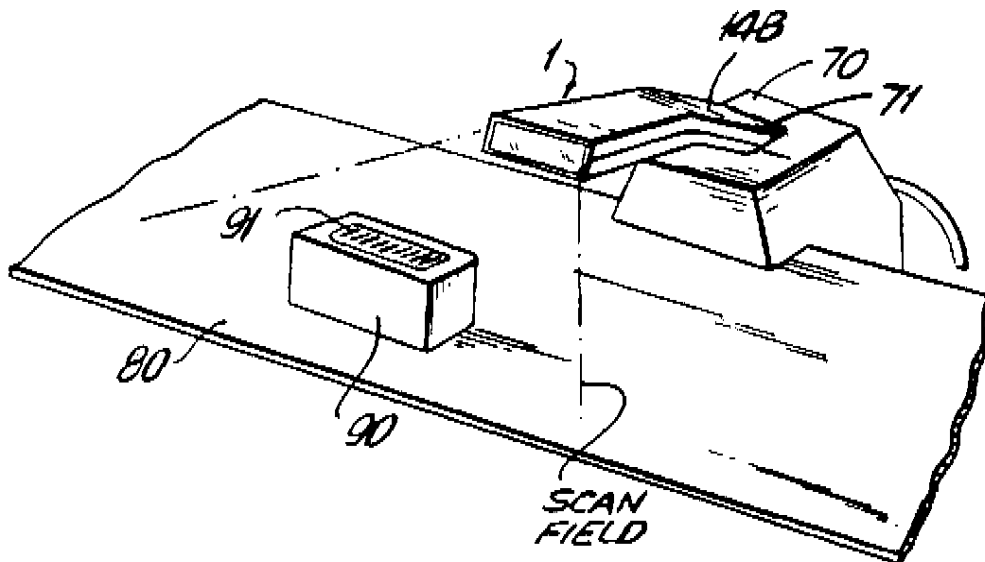

U.S. Patent

Aug. 17, 1999

Sheet 1 of 10

5,939,698

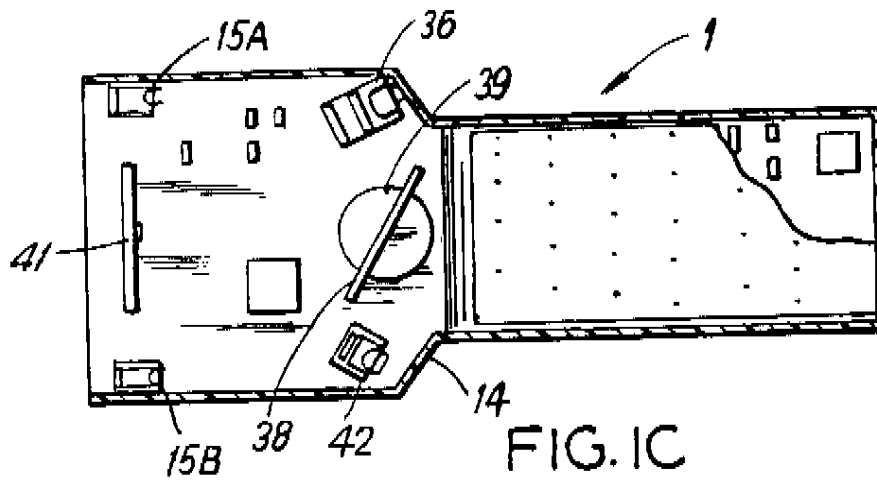
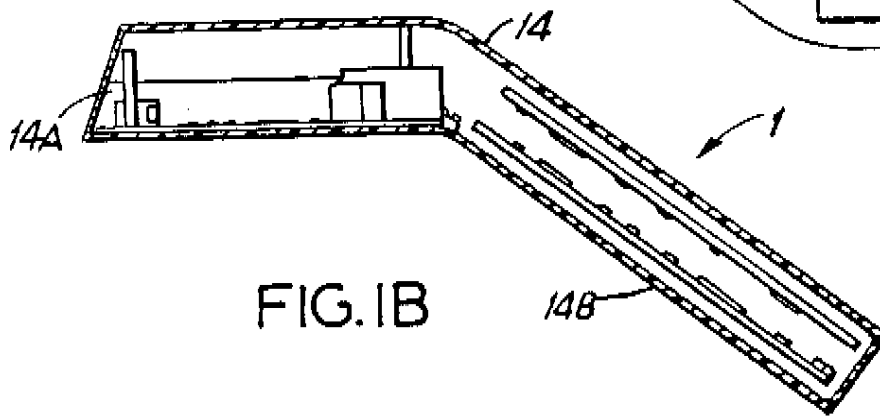
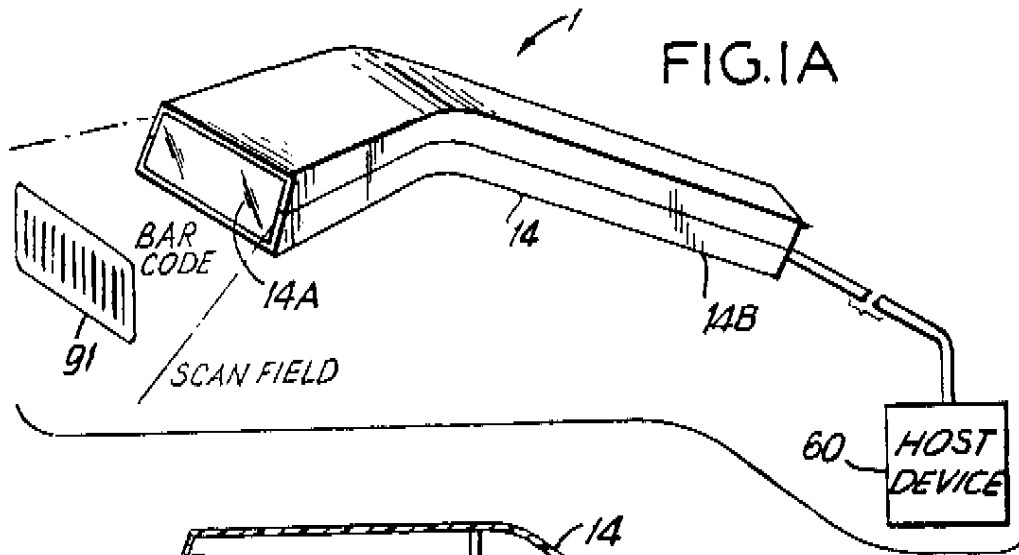

U.S. Patent

Aug. 17, 1999

Sheet 3 of 10

5,939,698

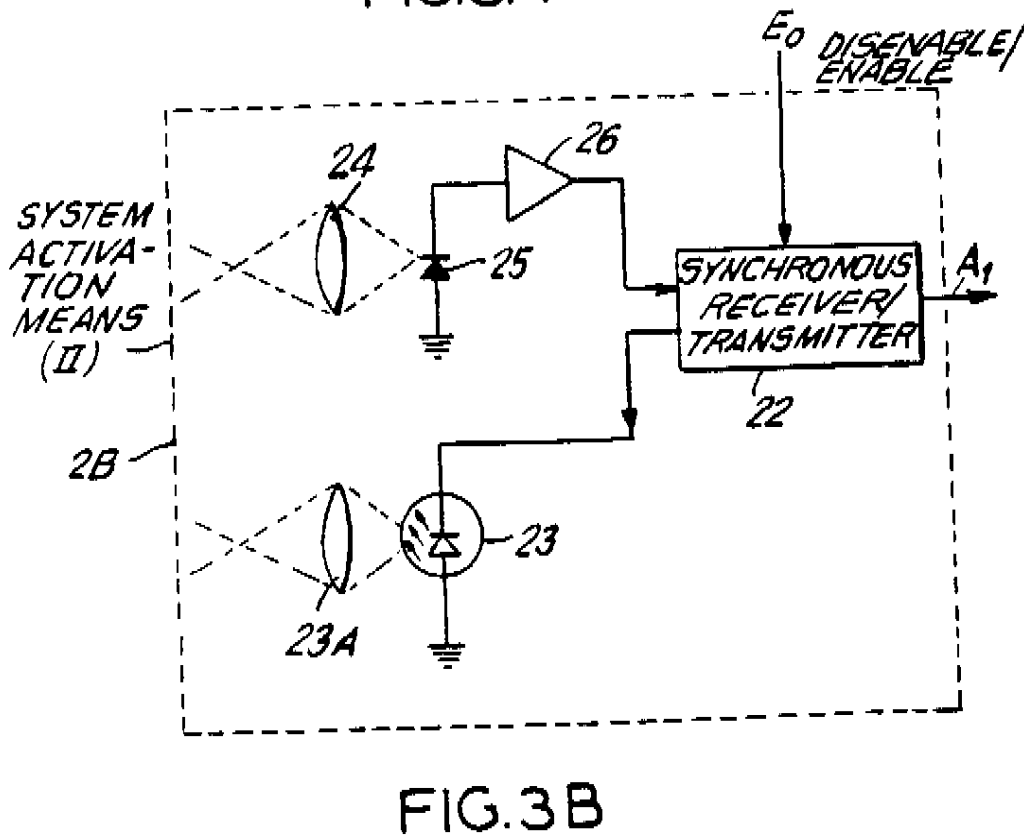
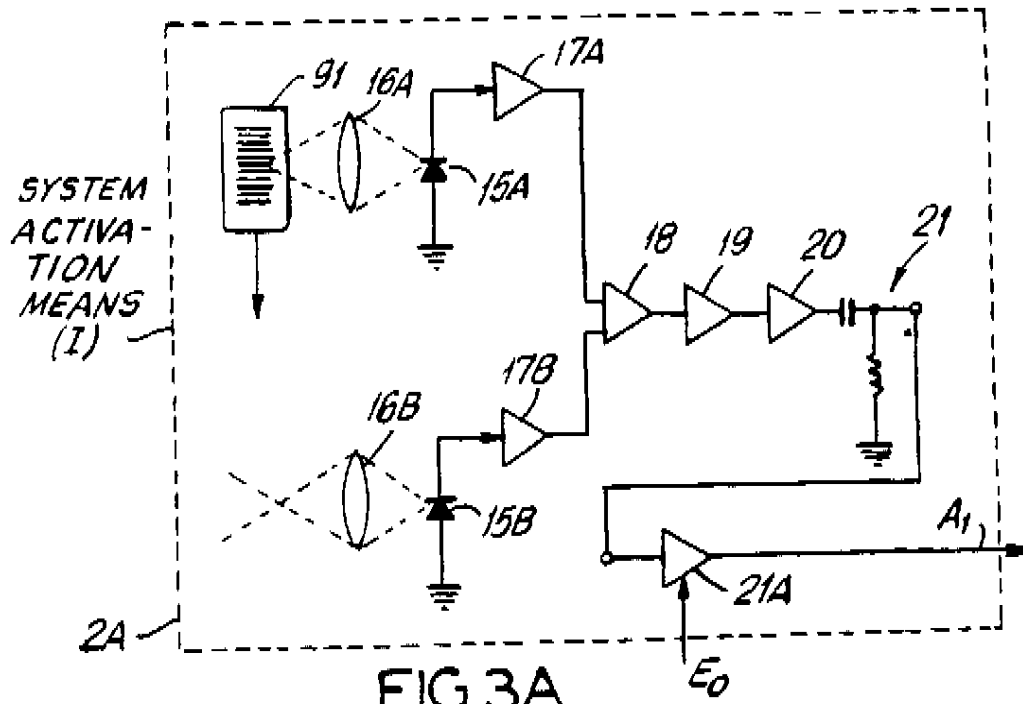

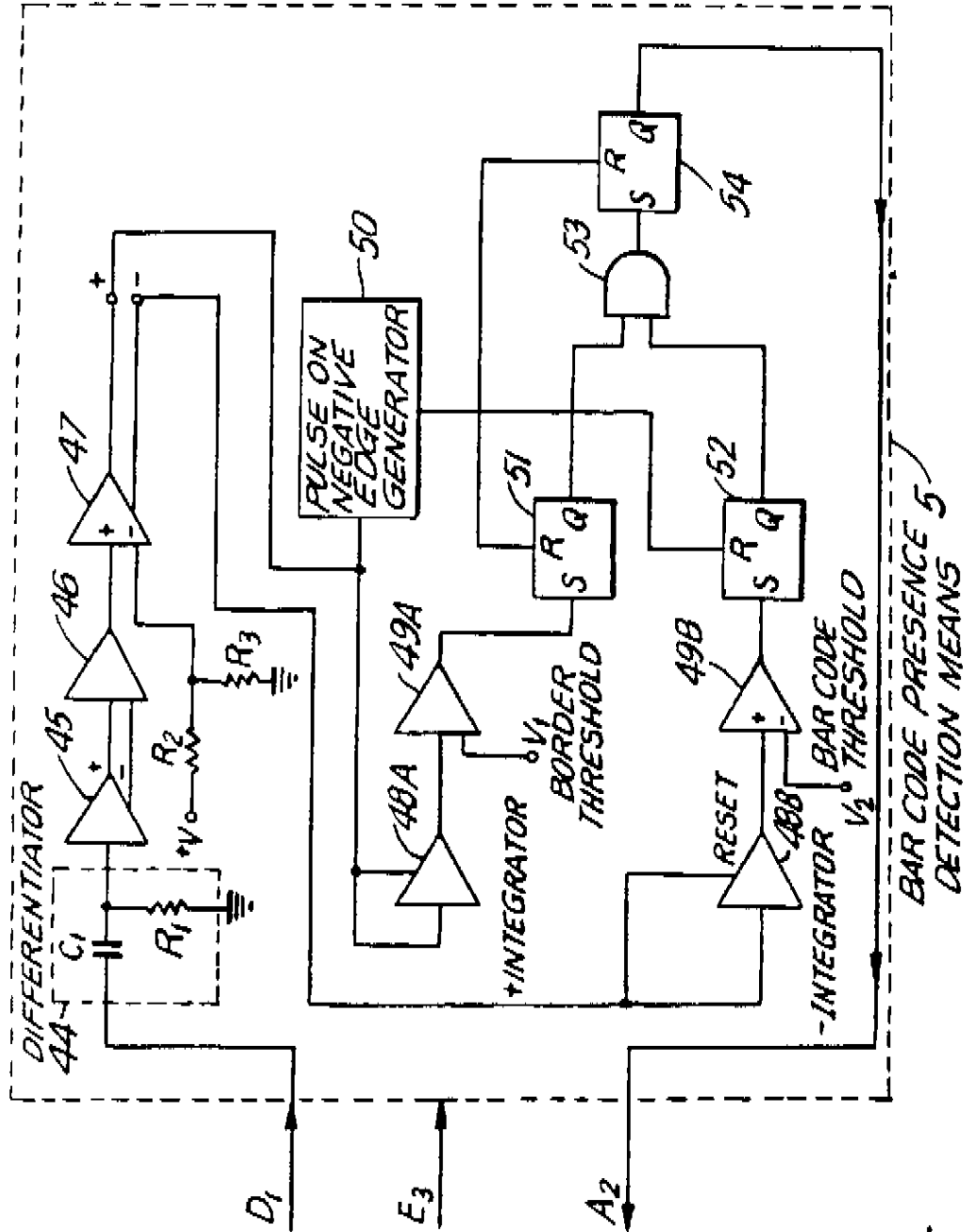

FIG. 4

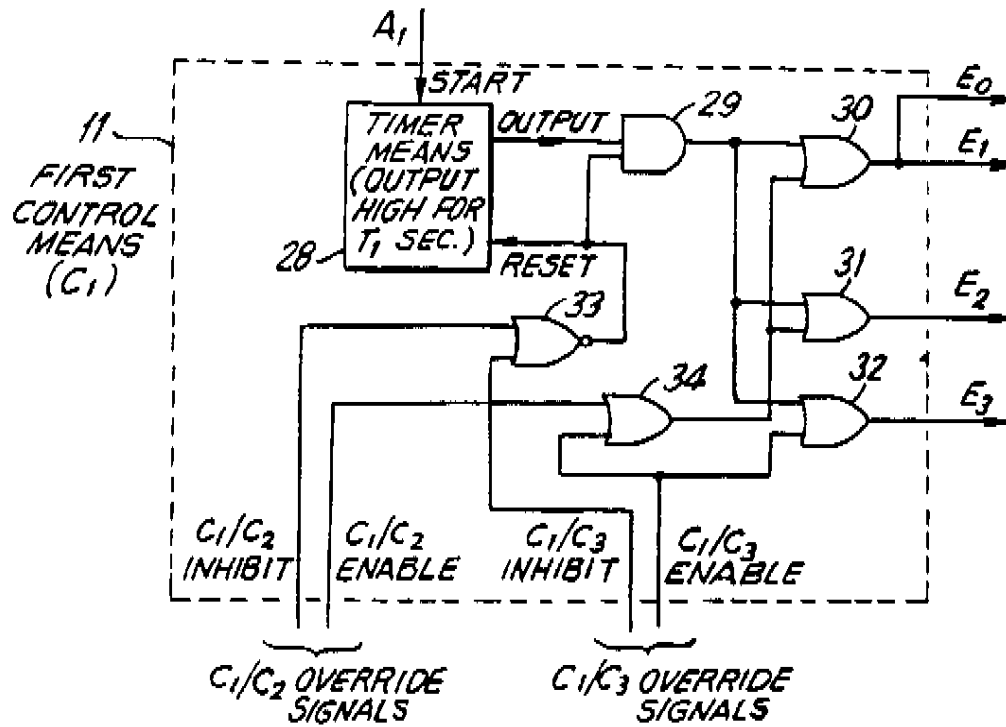

FIG. 5

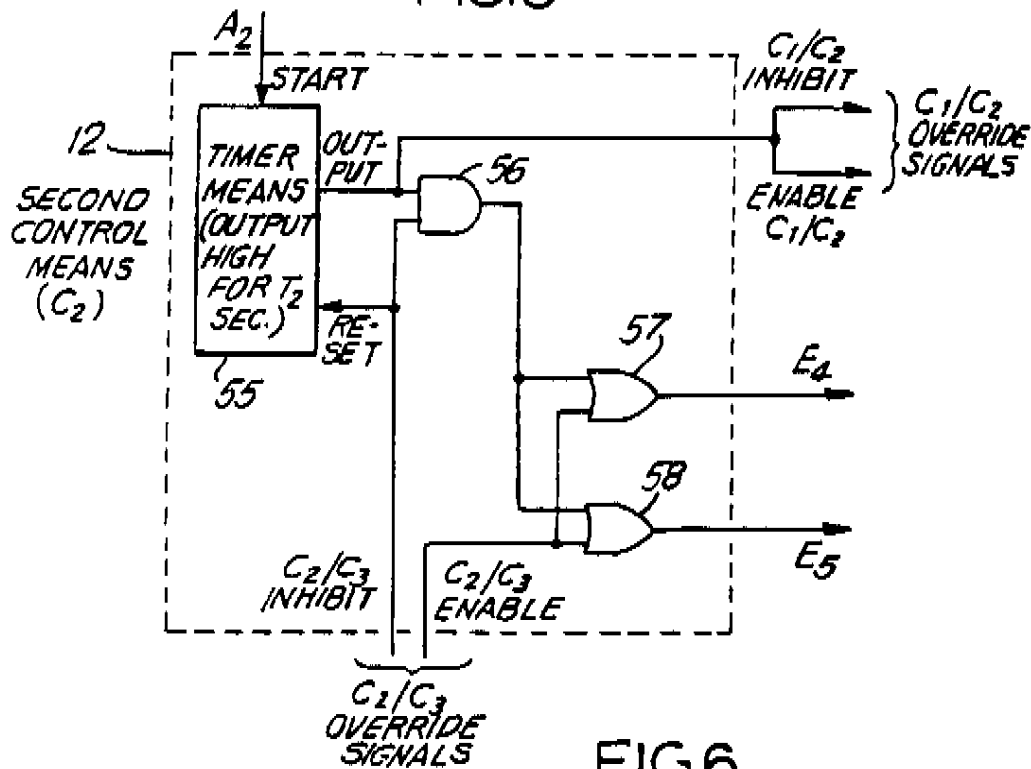

FIG. 6

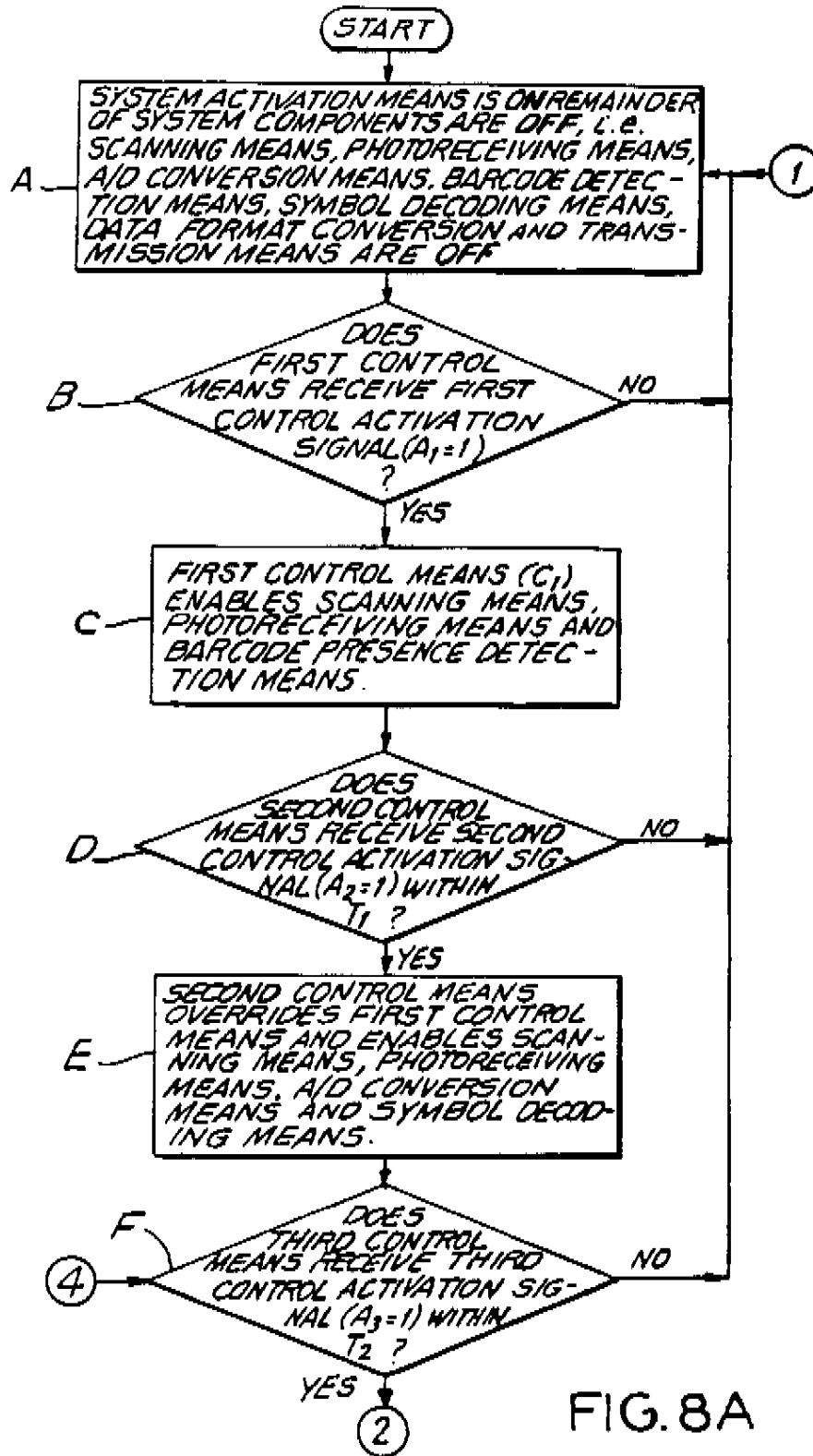
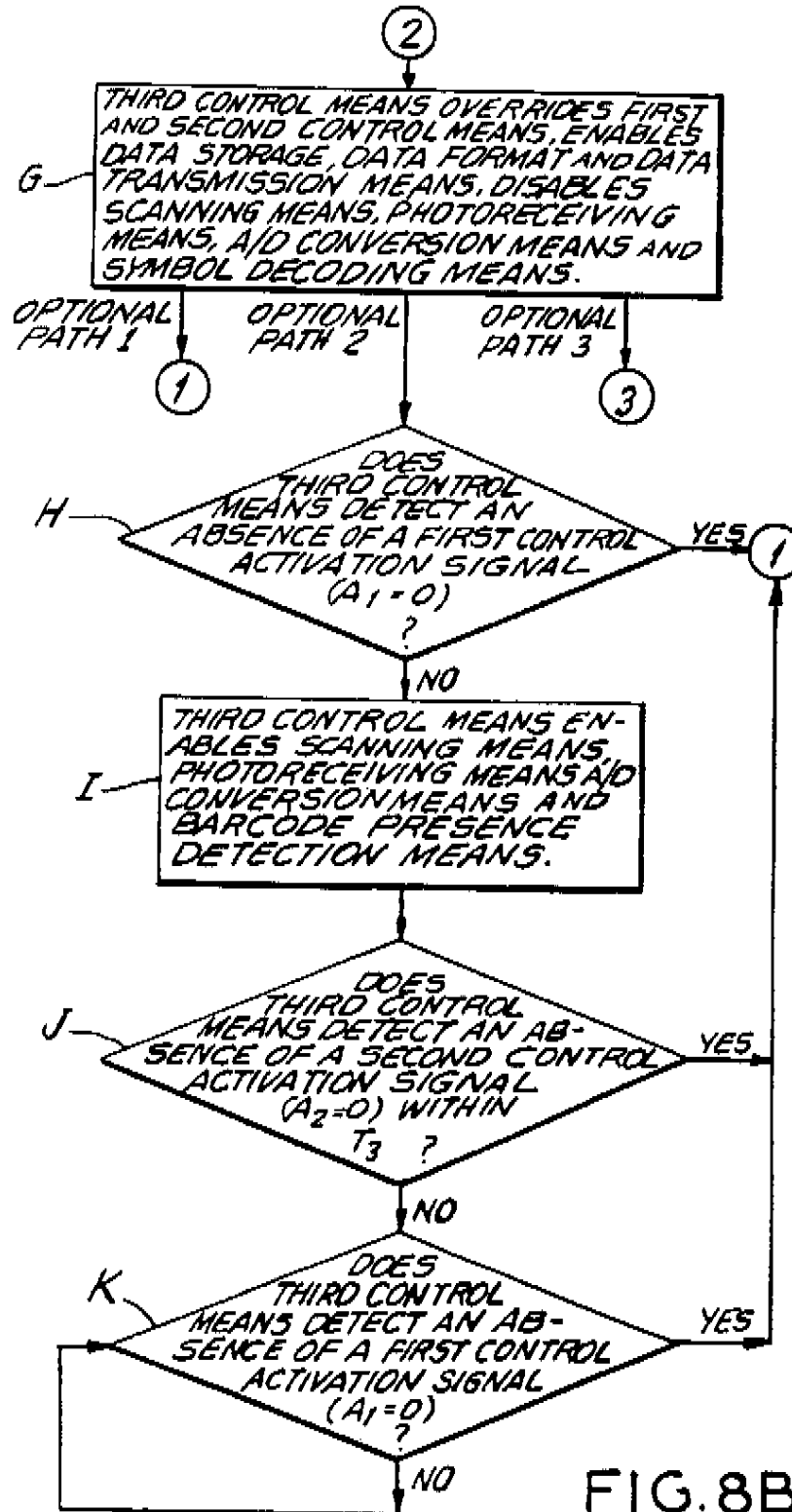

FIG. 8A



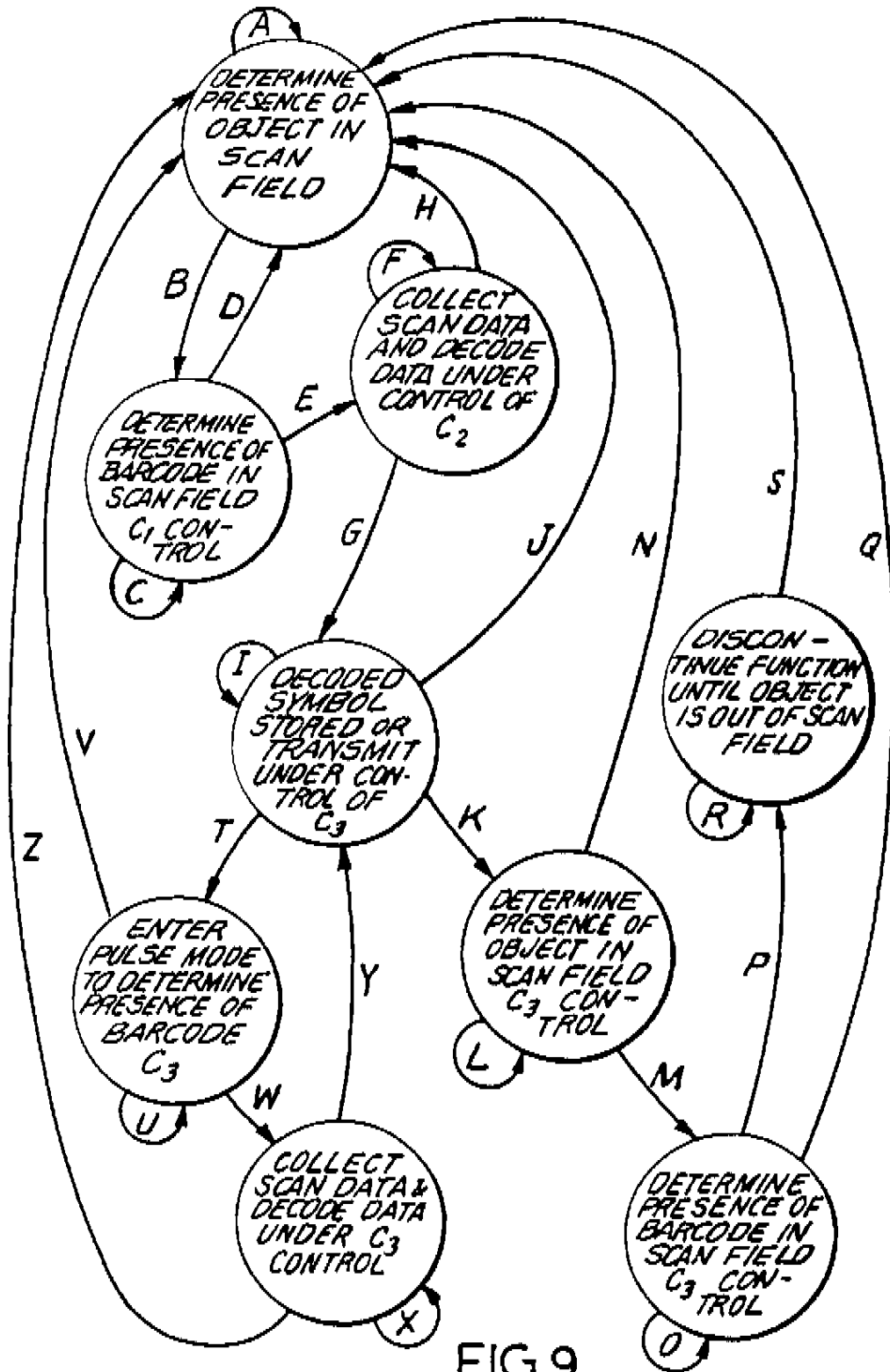

FIG. 9

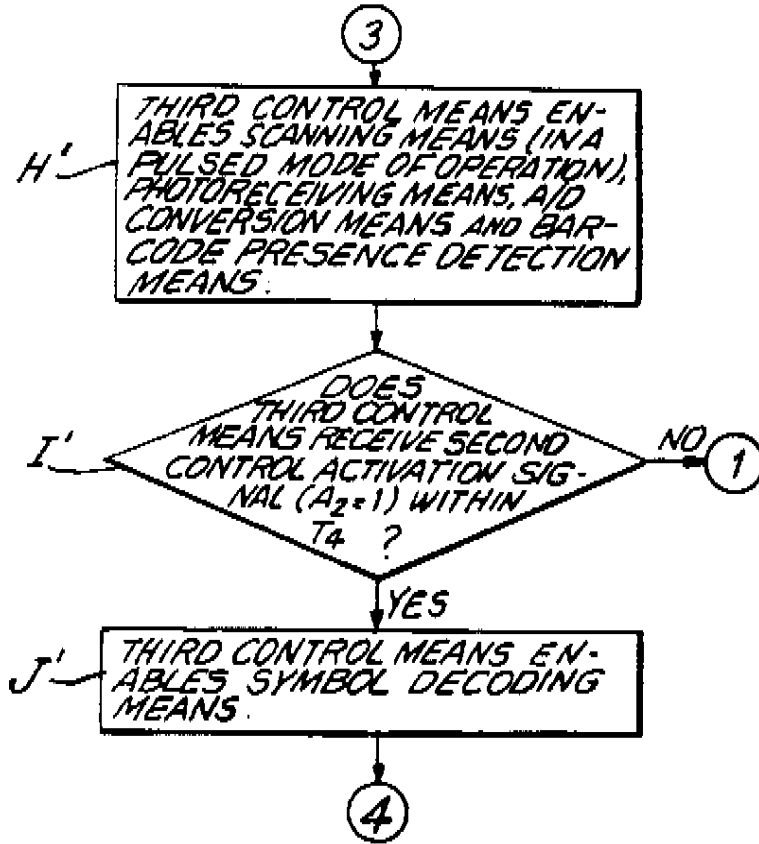
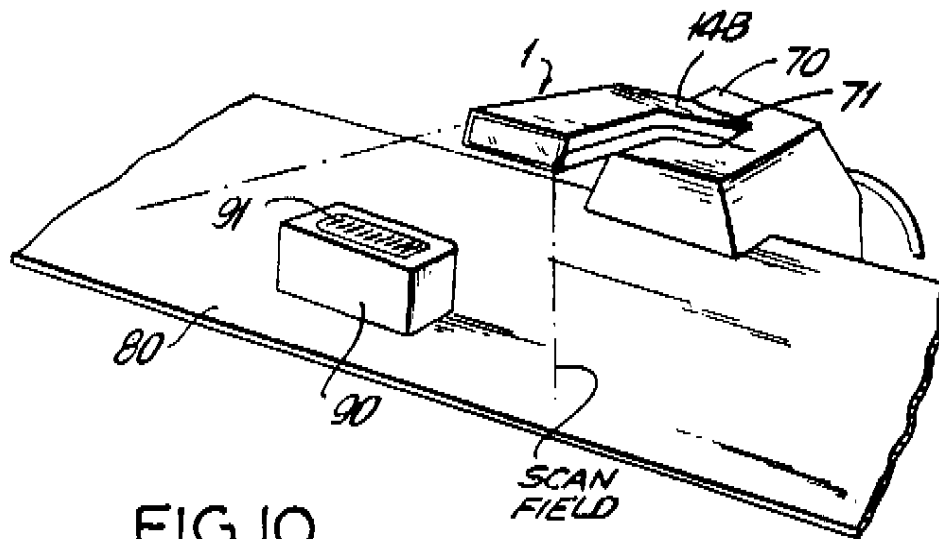

FIG. 8C



5,939,698

1

**BAR CODE SYMBOL READING SYSTEM
HAVING AUTOMATIC HAND-
SUPPORTABLE BAR CODING SYMBOL
READING DEVICE AND STAND FOR
SUPPORTING PROJECTED SCAN FIELD
THEREOF**

This is a Continuation of application Ser. No. 08/690,677 filed Jul. 31, 1996; which is a Continuation of application Ser. No. 08/476,069 filed Jun. 7, 1995 now U.S. Pat. No. 5,591,953; which is a Continuation of application Ser. No. 08/147,833 filed Nov. 4, 1993 now U.S. Pat. No. 5,424,525; with is a Continuation of application Ser. No. 07/583,421 filed Sep. 17, 1990 now U.S. Pat. No. 5,260,553.

BACKGROUND OF THE INVENTION

1. Field of the Invention

The present invention relates generally to automatic code symbol reading (i.e. recognition) systems, and more particularly to an automatic code symbol reading device having a control system which permits multiple modes of fully automated operation while conserving power and providing versatility in its method of use.

2. Brief Description of the Prior Art

Hitherto, a number of techniques have been proposed for reading bar code symbols using hand-held devices. Despite variety amongst prior art bar code symbol reading devices, the various techniques incorporated into prior art devices can be classified into two principally distinct classes, namely, manually operated or triggered bar code symbol reading, and automatic bar code symbol reading.

Representative of prior art manually operated bar code symbol reading devices are U.S. Pat. No. 4,387,297 to Swartz, et al., U.S. Pat. No. 4,575,625 to Knowles, and U.S. Pat. No. 4,845,349 to Cherry. While such prior art devices are capable of successful bar code symbol reading, they nevertheless suffer from several significant shortcomings and drawbacks. In particular, the user is required to manually pull a trigger or push a button each time scanning and decoding is to be cyclically initiated and terminated. The requirement is most fatiguing on the user when large numbers of bar code symbols are to be read. Also, in certain symbol reading applications, such as warehouse inventory, pulling the trigger to initiate scanning of bar code symbols may be extremely difficult for the user due to the physical location of the objects bearing the bar code symbols.

An alternative to manually operated a bar code symbol reading devices is use of automatic bar code symbol readers, which incorporate techniques for automatically initiating and terminating scanning and decoding operations. Representative of prior art automatic bar code symbol devices are U.S. Pat. No. 4,639,606 to Boles, et al. and U.S. Pat. No. 4,933,538 to Heiman et al. While capable of automatically initiating scanning of bar code symbols, such prior art devices and incorporated techniques nevertheless also suffer from significant shortcomings and drawbacks.

In particular, U.S. Pat. No. 4,639,606 to Boles, et al. discloses laser emission control circuitry for use in implementing a hand-held triggerless bar code scanner. The laser is operated in a pulsed "find paper" mode until a reflected signal is obtained, indicating the presence of an object (e.g., paper) in the search field. Thereupon, the circuitry is changed to a "search mode" in which the power of the laser is increased to above the safety limits for a period of time, and the return signal is monitored for signal transitions corresponding to the black bars of the code. On detection of

2

the first black bar, the circuitry is changed to an "in-code" (decode) mode as long as successive symbols are received within a given period of time. If the decode mode terminates within a predetermined time interval (e.g., one second after the beginning of the search mode), then the search mode is re-entered, otherwise the decode mode will change to find paper mode.

While the triggerless bar code symbol reader proposed in U.S. Pat. No. 4,639,606 possesses three modes of operation, this prior art bar code symbol reader nevertheless suffers from several significant shortcomings and drawbacks. In particular, this prior art bar code symbol reader requires continuous use of a pulsed laser beam to determine the presence of an object within the scan field, which, in hand-held portable battery power devices, undesirably drains limited power reserves, especially in extended time duration bar code reading applications. Also, this prior art device not knowing whether a bar code symbol is actually present in the scan field, requires commencement of decode processing upon detection of the first black bar. Undesirably, this typically necessitates powering and initializing a programmable device such as a microprocessor, for decoding scan data that may likely contain no bar code symbol at all. Consequently, this characteristic of such prior art bar code symbol reading devices results in further consumption of power.

U.S. Pat. No. 4,933,538 discloses a bar code symbol scanning system, which in the "object sensor mode" the scanner is triggerless and the constantly on laser beam normally emits at a narrow angle and low power. When an indicia pattern indicative of a bar code symbol has been detected, the laser beam will widen, the power of the beam will increase, and the beam will read the entire symbol. While this prior art scanning technique permits detection of bar code symbols within the scan field in order that the power of the laser beam may be automatically increased to a higher level for collecting scan data for use in decoding operations, this prior art system nevertheless suffers from several significant shortcomings and drawbacks as well. In particular, this prior art system requires continuous use of laser emission to determine the presence of both objects and bar code symbols within the scan field, which necessarily results in drain of limited power reserves in portable battery power applications. In addition, the extensive use of a laser beam to perform object and bar code symbol detection functions implicates necessity for laser emission control measures.

In general, prior art automatic bar code symbol reading devices also suffer from other shortcomings and drawbacks. For example, unlike manually operated devices which rely on the user to activate a trigger, once for each bar code to be read, prior art triggerless (i.e., automatic) bar code symbol reading devices lack intelligence capabilities necessary to prevent undesired multiple reading of bar code symbols, particularly when the scanning beam is permitted to dwell on a bar code symbol for extended periods of time.

Further, prior art automatic bar code symbol reading devices have lacked control capabilities which permits diverse modes of programmable system-control operation, while preventing misreads and inadvertent multiple reads and ensuring conservation of power.

Thus, there is a great need in the code symbol reading art for a fully automatic code symbol reading device which overcomes the above shortcomings and drawbacks of prior art devices and techniques.

Accordingly, it is a primary object of the present invention to provide a fully automatic hand-holdable bar code symbol

5,939,698

3

reading device capable of automatically reading bar code symbols in accordance with user-selectable system-control operations.

A further object of the present invention is to provide such an automatic bar code symbol reading device incorporating a control system having a plurality of control centers, each of which can be assigned predetermined control functions that enable operation of particular device components in accordance with a user-selected system-control operation.

A further object of the present invention is to provide such an automatic bar code symbol reading device, in which upon the occurrence of predetermined conditions, one or more of the control centers are capable of overriding certain of the other control centers so that a wide number of system-control operations can be carried out in a power conserving manner, to permit automatic reading of bar code symbols in a variety of diverse applications.

Another object of the present invention is to provide such an automatic bar code symbol reading device, in which the system control architecture readily permits extension of additional system-control operations by formulating and programming functions between a fixed number of control activation signals and enable signals provided as input and output signals respectively, to one or more control centers.

A further object of the present invention is to provide an automatic hand-holdable bar code symbol reading device which is capable of determining the presence of an object without enabling the scanning means of the device.

Another object of the present invention is to provide a hand-holdable bar code symbol reading device which is capable of distinguishing between a bar code symbol and a regular pattern of light and dark areas such as that formed by printed characters, and to only enable decode processing of scan data upon the detection of a bar code symbol in the scan field of the device. Consequently, the device is capable of disregarding all text within the scan field, and enabling the symbol decoder only by an actual bar code symbol.

An even further object of the present invention is to provide an automatic bar code symbol reading device which prevents multiple reading of bar code symbols due to dwelling of scanning beam upon a bar code symbol for an extended period of time.

Yet a further object of the present invention is to provide an improved method of automatically reading bar code symbols.

These and further objects of the present invention will become apparent hereinafter and in the claims.

SUMMARY OF THE INVENTION

According to one of the broader aspects of the present invention, there is provided a fully automatic hand-holdable bar code symbol reading system.

In general, the automatic bar code reading device comprises system activation means, scanning means, photoreceiving means, analog-to-digital conversion means, bar code presence detection means, and symbol decoding means. The purpose of the system activation means is to provide a first control activation signal indicative of the presence of an object in the scan field. The purpose of the scanning means is to produce a light beam and scan the light beam across the scan field. The purpose of the photoreceiving means is to detect at least a portion of light of variable intensity reflected off the object in the scan field and produce an analog signal indicative of the detected light intensity. The purpose of the analog-to-digital conversion means is to convert the analog

4

data signal into a digital data signal indicative of the detected light intensity. The purpose of the bar code presence detection means is to produce a second control activation signal upon detecting the presence of a bar code symbol on the object in the scan field, on the basis of the analog or digital data signal. The purpose of the symbol decoding means, on the other hand, is to produce symbol character data and a third control activation signal upon decoding a bar code symbol on the basis of the digital data signal. Notably, the produced symbol character data will correspond to the decoded bar code symbol.

Another aspect of the present invention is to embed the above-described system components within a control system having individual control centers, each of which are responsive to particular control activation signals generated by the system components. In accordance with the architecture of the control system, certain of the control centers can override other control centers, providing a marked increase in system-control operation and versatility.

Based on the control system of the present invention, it is yet further possible to now read bar code symbols in a fully automatic manner without risk of inadvertent multiple reads and the like, owing to the fact the control architecture of the present invention provides intelligence capabilities to the system.

BRIEF DESCRIPTION OF THE DRAWINGS

For a fuller understanding of the objects of the present invention, the Detailed Description of the Preferred Embodiment will be taken in connection with the drawings, wherein:

FIG. 1A is a perspective view of an automatic hand-holdable laser bar code symbol reading device constructed in accordance with the principles of the present invention;

FIG. 1B is a cross-sectional elevated side view along the longitudinal extent of the bar code symbol reading device of FIG. 1A, showing various hardware and software components used in realizing the illustrated embodiment;

FIG. 1C is a cross-sectional plan view along the longitudinal extent of the bar code symbol reading device of FIGS. 1A and 1B, also showing the various components used in realizing the illustrated embodiment;

FIG. 2 is block functional system diagram of the bar code symbol reading device of the present invention, illustrating the principal components of the device as being integrated within the control system hereof;

FIG. 3A is a block functional diagram of a first embodiment of the system activation means of the bar code symbol reading device of the present invention;

FIG. 3B is a block functional diagram of a second embodiment of the system activation means of the present invention;

FIG. 4 is a block functional diagram of the bar code presence detection means of the bar code symbol reading device of the present invention;

FIG. 5 is a logical functional diagram of the first control means of the control system of the present invention;

FIG. 6 is a logical function diagram of the second control means of the control system of the present invention;

FIG. 7A is a functional block diagram of the third control means of the control system of the present invention;

FIG. 7B is a flow chart of a control program carried out in the third control means for the case of system-control operation No. 2 (i.e., path option 2) of the illustrated embodiment;

5,939,698

5

FIGS. 8A, 8B and 8C, taken together, show a high level flow chart illustrating three user-selectable courses of programmed system operation that the control system of the illustrated embodiment may undergo;

FIG. 9 is a state diagram illustrating the various states that the bar code symbol reading device of the illustrated embodiment may undergo during the course of its operation; and

FIG. 10 is a perspective view of a surface-mountable support stand adapted for receipt of the hand-held bar code symbol reading device of the present invention and facilitating table top use thereof.

DETAILED DESCRIPTION OF THE PREFERRED EMBODIMENT

The automatic bar code symbol reading system 1 of the present invention, is generally illustrated in FIGS. 1 through 10.

As shown in FIG. 2, bar code symbol reading system 1 comprises a number of system components, namely, system activation means 2, scanning means 3, photoreceiving means 4, bar code presence detection means 5, analog-to-digital (A/D) conversion means 6, symbol decoding means 7, data format conversion means 8, symbol character data storage means 9, and data transmission means 10. As illustrated, these system components are embedded within a programmable control system having a unique architecture which provides a great degree of versatility in system capability and operation, as well as power conservation. The structure, function and advantages of this control system architecture will be described in great detail hereinafter.

The control system of the present invention comprises essentially three major components, namely first control means (C_1) 11, second control means (C_2) 12, and third control means (C_3) 13. As will be described in greater detail hereinafter, second control means 12 is capable of "overriding" (i.e., exhibit and/or enable) first control means 11, whereas third control means 13 is capable of overriding second control means 12 and first control means 11. As shown in FIG. 2, such control override functions are carried out by the generation of control override signals (i.e., C_1/C_2 , C_1/C_3 , and C_2/C_3) transmitted between respective control structures.

While not illustrated in the drawings for purposes of clarity and avoidance of obfuscation, automatic bar code symbol reading device 1 includes a conventional power supply which is capable of providing requisite power to each of the system components, when and for time prescribed by the control system hereof. Typically, an on/off power switch or functionally equivalent device will be provided external to housing 14 to permit the user to turn on device 1. When power switch is initially engaged to its ON position, power will only be provided to system activation means 2 to enable its operation, while, for example, only biasing voltages and the like are provided to all other system components so that they are each initially disabled from operation.

In accordance with the present invention, the purpose of system activation means 2 is to produce first control activation signal A_1 upon determining (i.e., detecting) the presence of an object (e.g., product, document, etc.) within the scan field of bar code symbol reading device 1, as illustrated in FIG. 1A. In turn, first control activation signal A_1 is provided as input to both first and third control means 11 and 13, respectively. In FIGS. 3A and 3B, two different approaches to generating first control activation signal A_1 are disclosed.

6

In FIG. 3A, a passive technique is illustrated, in which passive detection of ambient light within the scan field is performed in order to determine if an object is present within the scan field of the automatic bar code symbol reading device 1. As illustrated in FIG. 3A, passive ambient light detection circuit 2A comprises a pair of photo diodes 15A and 15B, which sense ambient light gathered from two different parts of the scan field in front of device 1, using focussing lenses 16A and 16B, respectively. The output signals of photodiodes 15A and 15B are converted to voltages by current-to-voltage amplifiers 17A and 17B respectively, and are provided as input to a differential amplifier 18. The output of differential amplifier 18 is provided as input to a sample and hold amplifier 19 in order to reject 60 and 120 Hz noise. Output signal of amplifier 19 is provided as input to a logarithmic amplifier 20 to compand signal swing. The output signal of logarithmic amplifier 20 is provided as input to a differentiator 21 and then to a comparator 21. The output of comparator 21 provides first control activation signal A_1 .

In FIG. 3B, an active technique is illustrated in which an infrared signal is transmitted out into the scan field and first control activation signal A_1 is generated upon receiving a reflection of the transmitted signal off an object within the scan field. As illustrated in FIG. 3B, infrared object detection circuit 2B comprises a synchronous receiver/transmitter 22, which includes an infrared LED 23 which generates a 900 nanometer pulsed signal at a rate of 2.0 KHZ. This pulsed signal is transmitted through focusing lens 23 to illuminate the scan field. When an object is present within the scan field, a reflected pulse signal is produced and focussed through focusing lens 24 onto photodiode 25. The output of photodiode is corrected to a voltage by current-to-voltage amplifier 26, and the output thereof is provided as input to receiver/transmitter 22, to synchronously compare the received signal with the transmitted signal and determine if an object is present in the scan field. If so, then synchronous receiver/transmitter 22 produces first control activation signal $A_1=1$ indicative of such condition. First control activation signal $A_1=1$ upon being generated activates first control means 11 which, in turn, enables operation of scanning means 3, photoreceiving means 4, and bar code presence detection means 5, as will be described in greater detail hereinafter. In order to conserve power and improve signal-to-noise ratio at photoreceiving means 4 during scan data collection operations, it is preferable for first control means 11 to generate and provide a disable signal E_0 to infrared object detection circuit 2B whenever first control means 11 enables the scanning means 3.

As illustrated in FIGS. 2 and 5, first control means 11 is preferably realized by a circuit capable of generating enabling signals E_1 , E_2 and E_3 for the scanning means, photoreceiving means and bar code presence detection means, respectively. As will be described in detail hereinafter, the specific operation of first control means 11 is dependent on the state of three sets of input signals, namely, first control activation signal A_1 , C_1 override signals from C_2 (i.e., C_1/C_2 inhibit signal and C_1/C_2 enable signal), and C_1 override signals from C_3 (i.e., C_1/C_3 inhibit signal and C_1/C_3 enable signal). As shown, first control activation control signal A_1 is provided to the "START" input of timer 28 upon which it produces a "high" output signal for a first predetermined time period (i.e., T_1 seconds). Preferably, time period T_1 is selected to be about 0.3 seconds.

As illustrated in FIG. 5, the output signal of timer 28 is provided as an input to AND gate 29, with its other input connected to the RESET input of timer 28. The output of

5,939,698

7

AND gate 29 is provided as an input to each of OR gates 30, 31 and 32. C_1/C_2 inhibit signal from second control means 12 and C_1/C_3 inhibit signal from third control means 13 are provided as inputs to NOR gate 33, whereas C_1/C_2 enable signal from second control means 12 and C_1/C_3 enable from third control means 13 are provided as inputs to OR gate 34. As shown, the output signal of OR gate 34 is provided to the other input of OR gates 30 and 31, whereas the output signal from NOR gate 33 is provided as input to AND gate 29. C_1/C_3 enable signal is also provided as input to OR gate 32, to complete the description of the circuit realization of first control means 11. As indicated in FIG. 5, the outputs of OR gates 30, 31 and 32 provide enable signals E_1 , E_2 and E_3 for the scanning means, photoreceiving means and bar code presence detection means, respectively. Notably, disable signal E_0 is produced from the output of OR gate 30.

As illustrated in FIG. 2, scanning means 3 comprises a light source 36 which, in general, may be any source of intense light suitably selected for maximizing the reflectivity from the object. In the preferred embodiment, light source 36 comprises a solid-state visible laser diode (VLD) which is driven by a conventional driver circuit 37. In order to deflect the laser beam output from laser diode 36 over a scan field having a predetermined spatial extent in front of front portion 14A of housing 14 in FIG. 1A, a conventional scanning mirror 38 can be oscillated back and forth by a stepper motor 39 driven by a conventional driver circuit 40, as shown. However, one of a variety of conventional scanning mechanisms may be alternatively used with excellent results. To selectively activate both laser light source 36 and motor 39, scanning means enable signal E_1 is provided as an input to both driver circuits 37 and 40. When enable signal E_1 is a logical "high" level (i.e., $E_1=1$), scanning means 3 is operable, a laser beam is generated and scanned across the scan field, and scan data is thereby produced off any object residing within the scan field.

In a conventional manner, when an object, such as product bearing a bar code symbol, is within the scan field at the time of scanning, the laser beam incident thereon will be reflected, producing a laser light return signal of variable intensity which represents a spatial variation of light reflectivity characteristic of the spaced apart pattern of bars comprising the bar code symbol. Photoreceiving means 4 is provided for the purpose of detecting at least a portion of laser light of variable intensity, which is reflected off the object and bar code symbol within the scan field. Upon such detection, photo receiving means 4 produces an analog data signal D_1 indicative of the detected light intensity. In general, photoreceiving means comprises scan data collection optics 41, such as a focusing mirror, which focus scan data signals for subsequent detection by a conventional photo receiver 42. Photoreceiver 42 in turn, produces an analog signal indicative of the intensity of the scan data signal, which is subsequently amplified by preamplifier 43 to produce analog scan data signal D_1 . In combination, scanning means 3 and photoreceiving means 4 operate to generate scan data from the scan field, over time intervals specified by first control means 11 during normal (i.e., noncontrol-override) modes of operation, and by third control means 13 during "control override" modes of operation. As will illustrated hereinafter, this scan data is used by both bar code presence detection means 5 and symbol decoding means 6.

As illustrated in FIG. 2, analog scan data signal D_1 is provided as input to both bar code presence detection means 5 as well as A/D conversion means 6. The primary purpose of bar code presence detection means 5 is to determine

8

whether a bar code is present in or absent from the scan field, over time intervals specified by first control means 11 during normal modes of operation and by third control means 13 during control override modes of operation. When the presence of a bar code symbol in the scan field is determined, the bar code presence detection means 5 generates second control activation signal A_2 (i.e., $A_2=1$) which is provided as input to second control means 12, as shown in FIG. 2.

As illustrated in FIG. 4, bar code presence detection means 5 is provided with enable signal E_3 which is used to enable circuitry employed in the realization of the bar code presence detection means. In the preferred embodiment, bar code presence detection means 5 is realized as a bar code envelope detector which processes analog scan data signal D_1 so as to produce a signal, the intensity of which indicates the general envelope of a bar code within the scan field. Upon such detection, bar code envelope detector 5 produces second control activation signal $A_2=1$ which is provided as input to second control means 12.

As shown in FIG. 3, analog scan data signal D_1 is provided as input to a differentiator 44 comprising capacitance element C_1 and resistive element R_1 , to produce the first derivative signal of signal D_1 . The first derivative signal is then amplified by a differential output amplifier 45, to produce as output amplified positive and negative first derivative signals, which in turn are provided as input to a positive peak detector 46. The output signal of positive peak detector 46 is provided as input to a comparator 47 which generates positive and negative bar code detect (BCD) signals.

As illustrated in FIG. 4, the positive and negative BCD signals are then provided as input and RESET signals to both integrators 48A and 48B. Positive BCD signal is also provided as input to pulse generator 50, which generates pulses upon the detection of the negative edges of the positive BCD signal. As shown, the output signals of integrators 48A and 48B are provided as first inputs to comparators 49A and 49B respectively, whereas an envelope border threshold voltage V_1 and bar code threshold voltage V_2 are provided as second inputs to comparators 49A and 49B, respectively. Border voltage V_1 is a DC reference voltage whose value can be determined on the basis of the time constant of integrator 48A, its gain, and the time duration of the minimum required "border width" of the bar code symbol. Bar code threshold V_2 is also a DC reference voltage whose value can be determined on the basis of the time constant of integrator 48B, its gain, and the time duration of the minimum required "bar code length".

The output of comparators 49A and 49B are provided to the S gates of latches 51 and 52, respectively, and the Q gates of these latches are provided as inputs to AND gate 53, as shown in FIG. 4. The output of AND gate 53 is provided as input to the S gate of latch 54, whereas the R gate of latch 54 is connected to the R gate of latch 51. The output of pulse generator 50 is provided as input to the R gate of latch 52. The output of latch 54 provides second control activation signal A_2 , which in turn, is provided as input to second control means 12, as shown in FIG. 2. The operation of the bar code envelope detector 5 is essentially as follows. If the output signals of both comparators 49A and 49B go "high" before the next RESET pulse from pulse generator 50 is provided to latch 52, then the output of latch 54 will go "high" (i.e., $A_2=1$) indicating that a bar code is present in the scan field.

In general, when the presence of a bar code in the scan field is detected, second activation control signal A_2 is

5,939,698

9

generated, second control means 12 is activated and first control means 11 is overridden by second control means 12 through the transmission of control override signals (i.e., C_1/C_2 inhibit and C_1/C_2 enable signals) from the second control means.

As illustrated in FIG. 6, second control means 12 preferably includes a timing means 55 whose output signal remains high for a second predetermined time period T_2 . Preferably, time period T_2 is selected to be about 1.0 seconds. Second control activation signal A_2 is provided to the start input of timing means 55, while the output thereof is provided as an input to AND gate 56, as shown. Third control means 13 provides a pair of C_2 override signals (i.e., C_2/C_3 A and C_2/C_3 B), as input to second control means 12, as shown in FIG. 2. The C_2/C_3 inhibit signal is provided to the second input of timing means 55. The C_2/C_3 enable signal, on the other hand, is provided to the first input of OR gates 57 and 58, whereas the output of AND gate 56 is provided as second input to each of OR gates 57 and 58. As illustrated in FIG. 6, the output signal of timing means provides both C_1/C_2 inhibit and C_1/C_2 enable signals, whereas the output of OR gates 57 and 58 provides enable signals E_4 and E_5 for enabling A/D conversion means 6 and symbol decoding means 7, respectively.

Upon detecting the presence of a bar code in the scan field, second control activation signal A_2 activates second control activation means 12, which, in turn, directly enables A/D conversion means 6 and symbol decoding means 7 by enabling signals E_4 and E_5 , respectively. Indirectly, second control means 12 enables scanning means 3 and photoreceiving means 4 and disables bar code presence detection means 5 by providing C_1 override signals to first control means 11.

A/D conversion means 7 can be realized by any conventional A/D circuit or chip, and functions to convert analog scan data signal D into a digital scan data signal D_2 , corresponding to the detected intensity of laser light collected and detected at photoreceiving means 4. The digitized scan data signal D_2 is provided as input to symbol decoding means 7, which scan line by scan line, decodes processes in a conventional manner, the stream of digitized scan data. The decoding means 7 processes a scan line of the digital scan data at a time, in an attempt to decode a valid bar code symbol within the second predetermined time period T_2 established and monitored by timing means 55 of second control means 12. If decoding means 7 successfully decodes a bar code symbol within time period T_2 , symbol character data D_3 (typically in ASCII code format) is produced corresponding to the decoded bar code symbol. Thereupon third control activation signal A_3 is produced by symbol decoding means 7 and is provided to third control means 13 to activate the same. In response, third control means 13 provides override control signals to first control 11 and second control means 12, as described hereinabove.

As illustrated in FIGS. 2 and 7, third control means 13 of the illustrated embodiment generates and provides enable signals E_6 , E_7 and E_8 to data format conversion means 8, data storage means 9 and data transmission means 10. As shown, symbol decoding means 7 provides symbol character data D_3 to data format means 8 to convert data D_3 into two differently formatted types of symbol character data, namely D_4 and D_5 . Format-converted symbol character data D_4 is of the "packed data" format, particularly adapted for efficient storage in data storage means 9. Format-converted symbol character data D_5 is particularly adapted for data transmission to a host device 60, such as a computer, or electronic cash register. When symbol character data D_4 is to be

10

converted into the format of the users choice based on a selected option mode, third control means 13 generates and provides enable signal E_6 to data storage means 9, as shown in FIG. 2. Similarly, when format converted data D_5 is to be transmitted to host device 60, the third control means 13 generates and provides enable signal E_8 to data transmission means 10, which thereupon transmits format-converted symbol character data D_5 to host device, via a conventional data transmission cable 61.

In the illustrated embodiment, third control means 13, symbol decoding means 7, and data format conversion means 8 and data storage means 9 are realized using a single programmable device, such as a microprocessor 63 having accessible memory and external timing means. In this way, conventional symbol decoding and data format conversion processing can be implemented in a straightforward manner. As for the programming microprocessor to realize third control means 13 and the control functions which it performs in the illustrated embodiment, reference is made to FIGS. 2, 5, 6, 7A and 7B in particular. In order to illustrate the nature of this programming and how it can be realized starting from a high level flow chart, System-Control Operation No. 2, illustrated in FIGS. 8A and 8B, will be used as an example.

In FIG. 7A, the third control means is shown implemented with a timer 64 and microprocessor 63, whose input pins I_1 through I_4 and output pins O_1 through O_8 are utilized in achieving the control functions performed during System-Control Operation No. 2. In order to illustrate the programmed operation of the third control means during System-Control operation No. 2, reference is made to FIGS. 7A and 7B of the drawings.

In FIG. 7A, the output of timer 64 is provided to input pin I_4 of microprocessor 63, whereas outputs O_7 and O_8 thereof are provided as start and reset signals respectively, to timer 64 as shown. Timer 63 is selected to elapse at T_3 , which preferably will be about 2-3 seconds. Notably, each input I_1 through I_4 , output O_1 through O_8 , control activation signals A_1 through A_3 , and enable signal E_1 through E_8 , may take on either a logical "high" value (i.e., 1), or a logical "low" value (i.e., 0). As illustrated in FIGS. 8A and 8B, during progression through System-Control Operation No. 2, the presence of third control activation signal A_3 (i.e., $A_3=1$) activates third control means 13. The presence of such signal value at the third control means indicates a valid bar code symbol has been decoded by symbol decoder 7. At the point of activation of third control means 13, the possible logical operations that may occur therewithin (illustrated in flow chart of FIG. 7B), are dependent upon the condition of the first and second control activation signals A_1 and A_2 and the input I_4 from the output of timer 64.

As illustrated in FIG. 7B, if control activation signals A_3 input at I_3 is "low" (i.e., $A_3=0$), then the control program of the third control means returns to "start" and once again continuously senses for the presence of third control activation signal (i.e., $A_3=1$). Otherwise, if third control activation signal A_3 input at I_3 is high (i.e., $A_3=1$), then the control program outputs O_2 , O_3 and O_7 as high, inhibiting first and second control means 11 and 12, and starting timer (T_3) 64, while toggling outputs O_5 and O_6 to enable data format conversion means 8 and data storage means 9 or data transmission means 10.

Then, the control program proceeds to determine whether the first control activation signal A_1 at input I_1 is absent (i.e., $A_1=0$), indicative of no object in scan field; if so, then the control program resets outputs O_2 and O_3 to return control

5,939,698

11

to the inhibited first and second control means, while toggling output O_2 to reset timer (T_3) 64. Otherwise, if input I_1 is high, indicative of an object in the scan field, then the control program outputs O_1 as high, enabling third control means 13 to override first control means 11, while enabling scanning means 3, photoreceiving means 4 and bar code presence detection means 5.

The control program then determines whether second control activation signal A_2 at input I_2 is low (i.e., $A_2=0$), indicative of no bar code present in the scan field; if so, the program resets outputs O_2 and O_3 to return control to the first and second control means, while toggling output O_2 to reset timer (T_3) 64. Otherwise, if second control activation signal A_2 at I_2 is high (i.e., $A_2=1$) indicative of a bar code present in the scan field, then the control program progresses to determine whether the output of timer 64 at input I_1 has gone low, indicative of timer elapse (i.e., $t \geq T_3$). In this event, the control program resets output O_1 to disable scanning means 3, photoreceiving means 4 and bar code detection means 5. If the input at I_1 is not low (i.e., $A_1=1$) indicative of timer 64 not yet elapsed, then the control program continues to determine whether the input at I_2 has gone low ($A_2=0$), indicative that a bar code symbol is no longer in the scan field. The control program will continue to repeat the above-described decision loop until either the bar code symbol disappears from the scan field or timer 64 elapses, whichever occurs first. If after timer 64 has elapsed and output O_1 has been reset, then the control program finally enters a last decision loop, to determine if first control activation signal A_1 at input I_1 has gone low, indicative that an object is no longer in the scan field. If it has, then the control program returns to start, as indicated in FIG. 7B. Otherwise, until input I_1 goes low, indicating that an object no longer remains in the scan field, the control program will continue to progress through this decision loop.

Notably, using the high level flow charts of FIGS. 8A and 8C, a control program for the third control means 13 can be implemented in a straightforward manner for System-Control Operation No. 3, illustrated in FIGS. 8B and 8C.

Having described the detailed structure and internal functions of bar code symbol reading device 1, it is now proper at this juncture to describe the operation of the control system hereof, for each of the three illustrated user-selectable System-Control Operations Nos. 1, 2 and 3.

Referring to blocks A to G in FIGS. 8A and 8B, System-Control Operation No. 1 is illustrated. Beginning at block A, hand-holdable device 1 is turned ON, which results in system activation means 2 being enabled (i.e., ON), while the remainder of the systems components (i.e., scanning means 3, photoreceiving means 4, A/D conversion means 6, bar code detection means 5, symbol decoding means 7, data format conversion means 8, data storage means 9 and data transmission means 10), being disabled (i.e., OFF). At block B, the control system then determines whether first control means 11 detects the presence of first control activation signal (i.e., $A_1=1$). If not, then the control system returns to block A; otherwise, if so, then as illustrated at block C, first control means 11 directly enables scanning means 3, photoreceiving means 4 and bar code presence detection means 5.

Then at block D, second control means 12 detects the presence of second control activation signal (i.e., $A_2=1$) within first predetermined time period T_1 . If $A_2=1$ is not present, then the control system returns to block A; and if so, then as indicated at block E, second control means 12 overrides first control means 11 and indirectly enables

12

scanning means 3, photoreceiving means 4, A/D conversion means 6, and symbol decoding means 7.

At block F, third control means 13 then detect the presence of third control activation signal (i.e., $A_3=1$) within second predetermined time period T_2 . If $A_3=1$ is not present within T_2 , then the control system returns to block A; and if so, then as indicated at block G, third control means 13 overrides first and second control means 11 and 12, and indirectly enables data format conversion means 8, and data storage means 9 or data transmission means 10 until these functions are achieved, and thereafter disables scanning means 3, photoreceiving means 4, A/D conversion means 6 and symbol decoding means 7. Thereafter, as shown in FIGS. 8A and 8B, the control system returns to block A, where only system activation means 2 is enabled.

Referring to blocks A through K in FIGS. 8A and 8B, System-Control (override) Operation No. 2 is illustrated. This system-control operation offers the advantage of being able to avoid multiple reading of bar code symbols due to the scanning beam dwelling on a bar code symbol for an extended period of time.

Essentially, System-Control Operation No. 2 comprises all but the last return operation of above-described System-Control Operation No. 1 and those additional operations represented by blocks G through K. After leaving block G, third control means 13 detects the absence of first control activation signal (i.e., $A_1=0$); and if absent, then the control system returns to block A. If first control activation signal A_1 is not absent but rather present (i.e., $A_1=1$), then third control means 13 indirectly enables through overridden first control means 11, scanning means 3 and the photoreceiving means 4, and through overridden second control means 12 indirectly enables A/D conversion means 6 and bar code presence detection means 5. Thereafter, at block J, third control means 13 detects the absence of second control activation signal (i.e., $A_2=0$) within predetermined time period T_3 . If signal A_2 is absent, then the control system returns to block A; and if signal A_2 is present (i.e., $A_2=1$), then third control means 13 enters a decision loop at block K. Here, third control means 13 in override mode continually detects the absence of the first activation signal (i.e., $A_1=0$), at which time the control system returns to block A.

Referring to blocks A through G and I' through J' in FIGS. 8A, 8B and 8C, System-Control Operation No. 3 is illustrated. This system-control operation offers the advantage of being able to simply read bar code symbols in inventory applications, while conserving battery power.

Essentially, System-Control Operation No. 3 comprises all but the last return operation of above-described System-Control Operation No. 1 and those additional operations represented by block H' through J'. After leaving block G, third control means 13 enables, through overridden first control means 11, scanning means 3 in a pulsed mode of operation (by providing a pulsed enable signal E_1 to laser driver 37). At block H', third control means 13 also enables through overridden first control means 11, photoreceiving means 3, and through overridden second control means 12, enables bar code presence detection means 5, and A/D conversion means 6.

Thereafter at block I', third control means 13 detects the presence of second control activation means (i.e., $A_2=1$) within a fourth predetermined time period T_4 , determined using an internal timer similar to timer (T_1) 64 in FIG. 7A. Preferably, the time duration of T_3 is selected to be about 5-10 seconds. If signal A_2 is not present but rather absent (i.e., $A_2=0$), then the control system returns to block A.

5,939,698

13

Otherwise, if signal A_2 is present, then third control means 13 enables, through overridden second control means 12, symbol decoding means 7. Thereafter, the control system returns to block E, shown in FIG. 8A.

Having described the operation of the control system of the bar code symbol reading device of present invention, it can also be helpful to understand the various states that device 1 may be in during the course of each particular system-control operation described above. In this regard, reference is made to FIG. 9 which provides a state diagram for the three system-control operations of the illustrated embodiment.

System-Control Operation No. 1 selected at option path 1, will be considered first. As illustrated in FIG. 9, when bar code symbol reading device is turned ON, only system activation means 2 is operative and all other system components are inoperative. This condition is indicated by state A, in which the device seeks to determine whether an object is in the scan field. Upon determination of the presence of an object in the scan field, the device will undergo state transition B, placing the device in state C.

In state C, the device seeks to determine within time T_1 the presence of a bar code in scan field, while under the control of first control means 11. If no bar code symbol is determined to be present in the scan field within time period T_1 , then the device will undergo state transition D, returning the device back to initial state A (indicated as "start" in FIG. 8A). On the other hand, if a bar code symbol is determined to be present in the scan field within time period T_1 , then the device will undergo state transition E, placing the device in state F.

In state F, the device collects bar code scan data D_1 under the control of second control means 12, converts scan data D_1 into scan data D_2 and decode processes this scan data, scan-line by scan-line, in an attempt to decode a valid bar code symbol within time period T_2 . If a bar code symbol is not decoded within time period T_2 , then the device undergoes state transition H, returning the device to initial state A. If on the other hand a valid bar code symbol is decoded within time period T_2 , symbol character data D_3 produced, and then the device undergoes state transition G, placing the device on "control-override" state I.

In state I, device 1 while under control of the third control means, converts the data format of symbol character data D_3 into either data D_4 or D_5 depending on whether the converted symbol character data is to be stored or transmitted to host device 60. Also in state I, the device either stores data D_5 in storage means 9, or transmits data D_5 to host device 60 via data transmission means 10 and data transmission cable 61, shown in FIG. 2. After completion of the above functions, the device undergoes state transition J (due to user-selection of System-Control Operation No. 1), returning the device to initial state A, completing a full path through System-Control Operation No. 1.

System-Control Operation No. 2, selected at option path 2, will now be considered. From control override state I, the device undergoes transition K, due to user-selection of System-Control Operation No. 2, placing the device in control-override state L. In state L, the device determines the presence of an object in the scan field, while under the override control of third control means 13. Upon determination of the presence of an object in the scan field device 1 undergoes state transition M, placing it into state O. On the other hand, if no object is determined to be within the scan field, then the device returns to initial state A.

In state O, the device seeks to determine the presence of a bar code symbol within the scan field, while the device is

14

under the control of third control means 13. If the device determines that no bar code symbol is within the scan field, then the device undergoes state transition Q, returning the device to initial state A. If on the other hand the device determines that a bar code symbol lies within the scan field, indicative of the scanning beam dwelling on a bar code symbol for an extended period of time, then the device undergoes state transition P, placing device 1 in control-override state R.

In state R, the device discontinues scanning, photoreceiving and bar code presence detection functions under the control of third control means 13, and continues to sense the presence of the object in the scan field until the object is removed therefrom. When the presence of the object is no longer detected within the scan field, then the device undergoes state transition S, returning the device to initial state A.

Lastly, System-Control Operation No. 3, selected at option path 3, is now considered. From control-override state I, the device undergoes state transition T, due to user-selection of System-Control Operation No. 3, placing the device in control-override state U. In state U, scanning means 3 is enabled in a pulsed-mode of operation under control of third control 13, photoreceiving means 4 and bar code presence detection means 5 are also enabled under third control means 13, and therewith the device seeks to detect the presence of a bar code symbol in the scan field within fourth predetermined time period T_4 . If a bar code symbol is not detected within time period T_4 , then the device undergoes state transition V and returns to initial state A under override control of third control means 13. If on the other hand, the presence of a bar code symbol is detected within time period T_4 , then the device undergoes state transition W, placing the device in control-override state X.

In state X, bar code scan data is collected scan-line by scan-line, and each scan line of data is decode processed in order to decode a valid bar code symbol. If a bar code symbol is decoded within time period T_2 , then symbol character data D_3 is produced and the device undergoes state transition Y, placing device in control-override state I under the control of third control means 13. There, symbol character data D_3 is format converted, and stored or transmitted as hereinbefore described. Thereafter, device 1 returns to state U under control of the third control means. If, however, a bar code symbol is not decoded within time period T_2 , then the device undergoes state transition Z, returning the device to state A while under the control of third control means 13.

The automatic hand-holdable bar code symbol reading device of the present invention may also be used as stationary bar code symbol reader, as shown in FIG. 10. There, a support stand 70 is shown having a receptacle 71 for receipt of housing handle portion 14B using support stand 70, device 1 can be mounted so as to position the scan field over a counter top 80 where goods 90 bearing bar codes 91 may be passed for reading.

While device 1 of the present invention has been provided with three user-selectable system-control (i.e., intelligence) operations, additional system-control operations may be provided to the control system hereof, in a manner as discussed hereinabove.

While the particular embodiment shown and described above has proven to be useful in many application in the code symbol reading art, further modification of the present invention herein disclosed will occur to persons skilled in the art to which the present invention pertains, and all such modifications are deemed to be within the scope and spirit of the present invention defined by the appended claims.

What is claimed is:

1. An automatic bar code symbol reading system having hand-held and stand-supported modes of automatic operation, comprising:

(a) a hand-supportable bar code symbol reading device 5 including

(1) a hand-supportable housing supportable in the hand of a user, and having a light transmission aperture through which visible light can exit and enter said hand-supportable housing;

(2) scan data producing means in said hand-supportable housing, for producing scan data from an object located in at least a portion of scan field definable external to said hand-supportable housing, said scan data producing means including

(i) a laser beam producing means disposed in said hand-supportable housing for producing and projecting a laser beam through said light transmission aperture, and

(ii) scanning means for scanning said laser beam across said scan field and a bar code symbol on said object, and

(iii) laser light detecting means for detecting the intensity of laser light reflected off said scanned bar code symbol and passed through said light transmission aperture, and automatically producing scan data indicative of said detected light intensity;

(3) bar code symbol detection means in said hand-supportable housing, for processing produced scan data so as to detect said scanned bar code symbol and automatically generate activation control signal in response to the detection of said scanned bar code symbol;

(4) symbol decoding means in said hand-supportable housing, and responsive to said activation control signal, for processing produced scan data so as to read said detected bar code symbol, and automatically produce symbol character data representative of said read bar code symbol; and

(5) system control circuitry for automatically controlling the operation of said automatic bar code symbol reading system,

wherein, during said hand-held mode of automatic operation, said control activation signal is automatically produced when a scanned bar code symbol is detected by said bar code symbol detection means while said hand-supportable bar code symbol reading device is supported within the hand of said user; and

(b) a scanner stand including

(1) housing support means for receiving and supporting at least a portion of said hand-supportable housing, and

(2) a base portion mountable relative to a countertop surface so that when said hand-supportable housing

is supported within said housing support means during said stand-supported mode of automatic operation, said scan field is projected away from said scanner support stand and said hand-supportable housing, and extends above said countertop surface permitting the automatic reading of bar code symbols on objects passed by said scanner support stand,

wherein, during said scanner-supported mode of automatic operation, said control activation signal is automatically produced when a scanned bar code symbol is detected by said bar code symbol detection means while said hand-supportable housing is supported within said housing support means.

2. The automatic bar code symbol reading system of claim 1, wherein said bar code symbol has first and second envelope borders, and said bar code symbol detection means detects said bar code symbol by detecting said first and second envelope borders.

3. The automatic bar code symbol reading system of claim 1, wherein said bar code symbol detection means comprises an electronic circuit for processing produced scan data indicative of said detected light intensity.

4. The automatic bar code symbol reading system of claim 1, further comprises an object detection means for automatically detecting an object in at least a portion of said scan field and generating said activation signal indicative of said detection.

5. The automatic bar code symbol reading system of claim 4, wherein said object detection means comprises, signal transmitting means for transmitting a signal into said scan field, and

signal receiving means for receiving said transmitted signal reflected off said object in at least a portion of said scan field, and automatically generating said activation signal indicative of the detection of said object in at least a portion of said scan field.

6. The automatic bar code symbol reading system of claim 5, wherein said signal transmitting means comprises an infra-red light source for transmitting a pulsed infra-red light signal, and wherein said signal receiving means comprises an infra-red light detector disposed in said hand-supportable housing.

7. The automatic bar code symbol reading system of claim 1, wherein said laser beam producing means comprises a laser diode for producing a visible laser beam.

8. The automatic bar code symbol reading system of claim 1, wherein said hand-supportable housing comprises a head portion and handle portion, and wherein said handle portion is received and supported within said housing support means.

9. The automatic bar code symbol reading system of claim 8, wherein said bar code detection means and said scan data producing means are disposed in said head portion.

* * * * *