

RYC 9/12/02 10:34

3:02-CV-01753 PANIP LLC V. BEACH PHOTO AND

3

AMDCMP.

FILED

02 SEP 11 PM 2:31

CLERK, U.S. DISTRICT COURT
SOUTHERN DISTRICT OF CALIFORNIA

BY:

DEPUTY

1 Kathleen M. Walker (#202185)
ATTORNEY AT LAW
2 3421 Thom Street
San Diego, California 92104
3 Telephone: (619) 255-0987
Facsimile: (619) 255-0986
4 e-mail: kwalkerlaw@cox.net

5 Attorney for Plaintiff

6
7 UNITED STATES DISTRICT COURT
8 SOUTHERN DISTRICT OF CALIFORNIA

9
10 PANIP LLC, a California limited liability company,)

Case No.: 02-CV-1753 L (POR)

11 Plaintiff,)

AMENDED COMPLAINT FOR PATENT INFRINGEMENT

12 vs.)

13 BEACH PHOTO & VIDEO, a Florida corporation; CR)

14 MAGNETICS, INC., a Missouri corporation; BURRAGE)

15 MUSIC CO., INC., a North Carolina corporation; HOBART)

16 SALES & SERVICES, a Nebraska corporation; ALL)

17 AMERICAN COLLECTIBLES, a New Jersey corporation;)

18 AMERICAN CINEMA EQUIPMENT, INC., an Oregon)

19 corporation; ADVANTAGE HEALTH SERVICES, INC., a)

20 Pennsylvania corporation; CAN-DO NATIONAL TAPE, a)

21 Tennessee corporation; SUPERIOR RECHARGE SYSTEMS,)

22 INC., a Texas corporation; and ARCADE ELECTRONICS,)

23 INC., a Virginia corporation,)

24 Defendants.)

ORIGINAL

3

1 Pursuant to Federal Rule of Civil Procedure 15(a), Plaintiff PANIP, LLC hereby amends
2 its complaint to correct a typographical error. Named defendant "American Health Services,
3 Inc." should be "ADVANTAGE HEALTH SERVICES, INC." All references herein have been
4 amended to the correct name of the defendant.
5

6 NATURE OF ACTION

7 This is an action for patent infringement of United States Letters Patent Numbers
8 5,576,951 and 6,289,319, pursuant to the laws of the United States of America as set forth in
9 Title 35 Sections 271 and 281 of the United States Code. The patents generally concern data
10 processing systems designed to facilitate commercial and financial transactions conducted
11 through the use of computers and related websites.
12

13 PanIP, for its Complaint, alleges as follows:

14 JURISDICTION AND VENUE

- 15 1) This Court has jurisdiction over the action pursuant to 35 U.S.C. §§ 101 *et seq.*, and 28
16 U.S.C. §§ 1331 and 1338(a) because the cause of action herein set forth arises under the Act
17 of Congress relating to patents. Venue is proper in this District pursuant to 28 U.S.C. §§
18 1391(b) and 1400(b).
19 2) On information and belief, BEACH PHOTO & VIDEO is a corporation organized and
20 existing under the laws of the State of Florida, and has a principal place of business at 604
21 Main Street, Daytona Beach, Florida 32118. As part of its business, Defendant maintains
22 and operates at least one website known as www.beachphoto.com.
23 3) On information and belief, CR MAGNETICS, INC. is a corporation organized and existing
24 under the laws of the State of Missouri, and has a principal place of business at 544
25

1 Axminister Drive, Fenton, Missouri, 63026. As part of its business, Defendant maintains and
2 operates at least one website known as www.crmagnetics.com.

3 4) On information and belief, BURRAGE MUSIC CO., INC. is a corporation organized and
4 existing under the laws of the State of North Carolina, and has a principal place of business at
5 4900 Green Road, Raleigh, North Carolina 27616. As part of its business, Defendant
6 maintains and operates at least one website known as www.burragemusic.com.

7 5) On information and belief, HOBART SALES & SERVICES is a corporation organized and
8 existing under the laws of the State of Nebraska, and has a principal place of business at
9 10905 Harrison Street, Omaha, Nebraska 68128. As part of its business, Defendant
10 maintains and operates at least one website known as www.friscospices.com.

11 6) On information and belief, ALL AMERICAN COLLECTIBLES is a corporation organized
12 and existing under the laws of the State of New Jersey, and has a principal place of business
13 at 22-08 Route 208 South, Fair Lawn, New Jersey 07410. As part of its business, Defendant
14 maintains and operates at least one website known as www.aacsportsmemorabilia.com.

15 7) On information and belief, AMERICAN CINEMA EQUIPMENT, INC. is a corporation
16 organized and existing under the laws of the State of Oregon, and has a principal place of
17 business at 1927 N. Argyle Street, Portland, Oregon 97217. As part of its business,
18 Defendant maintains and operates at least one website known as www.cinequip.com.

19 8) On information and belief, ADVANTAGE HEALTH SERVICES, INC. is a corporation
20 organized and existing under the laws of the State of Pennsylvania, and has a principal place
21 of business at 735 York Road, Willow Grove, Pennsylvania 19090. As part of its business,
22 Defendant maintains and operates at least one website known as www.advantagerx.com.

1 9) On information and belief, CAN-DO NATIONAL TAPE is a corporation organized and
2 existing under the laws of the State of Tennessee, and has a principal place of business at 195
3 Polk Avenue, Nashville, Tennessee 37210. As part of its business, Defendant maintains and
4 operates at least one website known as www.can-dotape.com.

5 10) On information and belief, SUPERIOR RECHARGE SYSTEMS, INC. is a corporation
6 organized and existing under the laws of the State of Texas, and has a principal place of
7 business at 1525 Hinton Street, Dallas, Texas 75235. As part of its business, Defendant
8 maintains and operates at least one website known as www.srsproducts.com.

9 11) On information and belief, ARCADE ELECTRONICS, INC. is a corporation organized and
10 existing under the laws of the State of Virginia, and has a principal place of business at 5655-
11 F General Washington Drive, Alexandria, Virginia 22312. As part of its business, Defendant
12 maintains and operates at least one website known as www.arcade-electronics.com.

13 12) PanIP is a limited liability company organized and existing under the laws of the State of
14 California, and has a principal place of business at 329 Laurel Street, San Diego, California
15 92101-1630. PanIP has received valid exclusive licenses for the patents from the inventor,
16 Lawrence B. Lockwood.

17 13) On information and belief, all of the Defendants have had regular and continuous business
18 presence within the Southern District of California, and Defendants have purposefully used a
19 computerized system for distributing a variety of information, goods and services and
20 processing of business and financial transactions through their websites within the Southern
21 District of California, either directly or through others. Accordingly, Defendants are subject
22 to personal jurisdiction in the Southern District of California pursuant to California CCP
23 410.10.
24
25

1 THE DISPUTE

2 14) PanIP has a number of patents related to computer commerce. Defendants are unrelated
3 corporations that conduct business via a computerized system for distributing a variety of
4 information, goods and services and processing of business and financial transactions,
5 predominately their websites.

6 15) PanIP is the exclusive licensee of U.S. Patent No. 5,576,951 and U.S. Patent No. 6,289,319,
7 which are valid and enforceable, and which PanIP believes are infringed by Defendants.
8

9 COUNT I

10 PATENT INFRINGEMENT OF U.S. PATENT NO. 5,576,951

11 (AGAINST ALL DEFENDANTS)

12 16) PanIP incorporates by reference herein paragraphs 1-15 of this Complaint as if restated
13 herein.

14 17) On November 19, 1996, United States Patent No. 5,576,951 ("the '951 patent") for
15 "AUTOMATED SALES AND SERVICES SYSTEM" was duly and legally issued by the
16 United States Patent and Trademark Office to Lawrence B. Lockwood. Subsequently, Mr.
17 Lockwood licensed the patent to PanIP. A true and correct copy of the '951 patent is
18 attached as Exhibit A to this Complaint.

19 18) On information and belief, without license or authorization from PanIP, Defendants have
20 been infringing the '951 patent within the United States by using the patented technology
21 which falls within the scope of at least claim 10 of the '951 patent.
22

23 19) On information and belief, without license or authorization from PanIP, Defendants have
24 been inducing others to infringe the '951 patent by engaging in certain aspects of
25 computerized commerce.

1 20) PanIP has been, and still is, being damaged by the Defendants' infringing activities.

2 Defendants will continue their infringing activities unless enjoined by this Court.

3 21) PanIP has no adequate remedy at law. The said conduct of Defendants has caused, and if not
4 enjoined, will continue to cause, irreparable damage to the rights of PanIP. PanIP's damages
5 from the aforesaid actions of Defendants, to the extent ascertainable, are not yet determined.

6
7 **COUNT II**

8 **PATENT INFRINGEMENT OF U.S. PATENT NO. 6,289,319**

9 **(AGAINST ALL DEFENDANTS)**

10 22) PanIP incorporates by reference herein paragraphs 1-21 of this Complaint as if restated
11 herein.

12 23) On September 11, 2001, United States Patent No. 6,289,319 ("the '319 patent") for
13 "AUTOMATIC BUSINESS AND FINANCIAL TRANSACTION PROCESSING
14 SYSTEM" was duly and legally issued by the United States Patent and Trademark Office to
15 Lawrence B. Lockwood. Subsequently, Mr. Lockwood licensed the patent to PanIP. A true
16 and correct copy of the '319 patent is attached as Exhibit B to this Complaint.

17 24) On information and belief, without license or authorization from PanIP, Defendants have
18 been infringing the '319 patent within the United States by using the patented technology
19 which falls within the scope of at least claim 1 of the '319 patent.

20 25) On information and belief, without license or authorization from PanIP, Defendants have
21 been inducing others to infringe the '319 patent by engaging in certain aspects of
22 computerized commerce.

23
24 26) PanIP has been, and still is, being damaged by the Defendants' infringing activities.
25 Defendants will continue their infringing activities unless enjoined by this Court.

1 27) PanIP has no adequate remedy at law. The said conduct of Defendants has caused, and if not
2 enjoined, will continue to cause, irreparable damage to the rights of PanIP. PanIP's damages
3 from the aforesaid actions of Defendants, to the extent ascertainable, are not yet determined.

4 WHEREFORE, PanIP respectfully demands judgment for PanIP, and against Defendants
5 for Count I:

- 6 a) That U.S. Patent No. 5,576,951 is valid, and has been infringed by Defendants' use of
7 the patented technology which falls within the scope of one or more claims of the
8 '951 patent;
9
10 b) Ordering a preliminary and final injunction enjoining Defendants from further
11 infringement and the inducement of infringement of U.S. Patent No. 5,576,951 and
12 require Defendants to furnish in writing to Plaintiff a report that describes in detail
13 how Defendants have complied with the injunction;
14
15 c) Ordering that an accounting be made to establish PanIP's damages arising out of
16 Defendants' acts;
17
18 d) Awarding PanIP its reasonable attorneys' fees and costs incurred in this action; and
19
20 e) Awarding PanIP such other and further relief as this Court may deem just and proper.

21
22
23
24
25
26
27
28
29
30
31
32
33
34
35
36
37
38
39
40
41
42
43
44
45
46
47
48
49
50
51
52
53
54
55
56
57
58
59
60
61
62
63
64
65
66
67
68
69
70
71
72
73
74
75
76
77
78
79
80
81
82
83
84
85
86
87
88
89
90
91
92
93
94
95
96
97
98
99
100
101
102
103
104
105
106
107
108
109
110
111
112
113
114
115
116
117
118
119
120
121
122
123
124
125
126
127
128
129
130
131
132
133
134
135
136
137
138
139
140
141
142
143
144
145
146
147
148
149
150
151
152
153
154
155
156
157
158
159
160
161
162
163
164
165
166
167
168
169
170
171
172
173
174
175
176
177
178
179
180
181
182
183
184
185
186
187
188
189
190
191
192
193
194
195
196
197
198
199
200
201
202
203
204
205
206
207
208
209
210
211
212
213
214
215
216
217
218
219
220
221
222
223
224
225
226
227
228
229
230
231
232
233
234
235
236
237
238
239
240
241
242
243
244
245
246
247
248
249
250
251
252
253
254
255
256
257
258
259
260
261
262
263
264
265
266
267
268
269
270
271
272
273
274
275
276
277
278
279
280
281
282
283
284
285
286
287
288
289
290
291
292
293
294
295
296
297
298
299
300
301
302
303
304
305
306
307
308
309
310
311
312
313
314
315
316
317
318
319
320
321
322
323
324
325
326
327
328
329
330
331
332
333
334
335
336
337
338
339
340
341
342
343
344
345
346
347
348
349
350
351
352
353
354
355
356
357
358
359
360
361
362
363
364
365
366
367
368
369
370
371
372
373
374
375
376
377
378
379
380
381
382
383
384
385
386
387
388
389
390
391
392
393
394
395
396
397
398
399
400
401
402
403
404
405
406
407
408
409
410
411
412
413
414
415
416
417
418
419
420
421
422
423
424
425
426
427
428
429
430
431
432
433
434
435
436
437
438
439
440
441
442
443
444
445
446
447
448
449
450
451
452
453
454
455
456
457
458
459
460
461
462
463
464
465
466
467
468
469
470
471
472
473
474
475
476
477
478
479
480
481
482
483
484
485
486
487
488
489
490
491
492
493
494
495
496
497
498
499
500
501
502
503
504
505
506
507
508
509
510
511
512
513
514
515
516
517
518
519
520
521
522
523
524
525
526
527
528
529
530
531
532
533
534
535
536
537
538
539
540
541
542
543
544
545
546
547
548
549
550
551
552
553
554
555
556
557
558
559
560
561
562
563
564
565
566
567
568
569
570
571
572
573
574
575
576
577
578
579
580
581
582
583
584
585
586
587
588
589
590
591
592
593
594
595
596
597
598
599
600
601
602
603
604
605
606
607
608
609
610
611
612
613
614
615
616
617
618
619
620
621
622
623
624
625
626
627
628
629
630
631
632
633
634
635
636
637
638
639
640
641
642
643
644
645
646
647
648
649
650
651
652
653
654
655
656
657
658
659
660
661
662
663
664
665
666
667
668
669
670
671
672
673
674
675
676
677
678
679
680
681
682
683
684
685
686
687
688
689
690
691
692
693
694
695
696
697
698
699
700
701
702
703
704
705
706
707
708
709
710
711
712
713
714
715
716
717
718
719
720
721
722
723
724
725
726
727
728
729
730
731
732
733
734
735
736
737
738
739
740
741
742
743
744
745
746
747
748
749
750
751
752
753
754
755
756
757
758
759
760
761
762
763
764
765
766
767
768
769
770
771
772
773
774
775
776
777
778
779
780
781
782
783
784
785
786
787
788
789
790
791
792
793
794
795
796
797
798
799
800
801
802
803
804
805
806
807
808
809
810
811
812
813
814
815
816
817
818
819
820
821
822
823
824
825
826
827
828
829
830
831
832
833
834
835
836
837
838
839
840
841
842
843
844
845
846
847
848
849
850
851
852
853
854
855
856
857
858
859
860
861
862
863
864
865
866
867
868
869
870
871
872
873
874
875
876
877
878
879
880
881
882
883
884
885
886
887
888
889
890
891
892
893
894
895
896
897
898
899
900
901
902
903
904
905
906
907
908
909
910
911
912
913
914
915
916
917
918
919
920
921
922
923
924
925
926
927
928
929
930
931
932
933
934
935
936
937
938
939
940
941
942
943
944
945
946
947
948
949
950
951
952
953
954
955
956
957
958
959
960
961
962
963
964
965
966
967
968
969
970
971
972
973
974
975
976
977
978
979
980
981
982
983
984
985
986
987
988
989
990
991
992
993
994
995
996
997
998
999
1000

FURTHER, PanIP respectfully demands judgment for PanIP, and against Defendants for
Count II:

- a) That U.S. Patent No. 6,289,319 is valid, and has been infringed by Defendants' use of the
patented technology which falls within the scope of one or more claims of the '319
patent;
b) Ordering a preliminary and final injunction enjoining Defendants from further
infringement and the inducement of infringement of U.S. Patent No. 6,289,319 and

1 require Defendants to furnish in writing to Plaintiff a report that describes in detail how
2 Defendants have complied with the injunction;

- 3 c) Ordering that an accounting be made to establish PanIP's damages arising out of
4 Defendants' acts;
- 5 d) Awarding PanIP its reasonable attorneys' fees and costs incurred in this action; and
6 e) Awarding PanIP such other and further relief as this Court may deem just and proper.
7

8 DEMAND FOR TRIAL BY JURY

9 Pursuant to Federal Rule of Civil Procedure 38, Plaintiff PanIP respectfully
10 demands a trial by jury on all issues so triable.

11
12
13 Dated: September 11, 2002

By: 

14 Kathleen M. Walker

15 Attorney for Plaintiff
16 PanIP LLC
17
18
19
20
21
22
23
24
25

PROOF OF SERVICE

1
2
3 1. I am over the age of 18, not a party to this cause. I am a resident of San Diego
4 County, California, where this service took place.

5 2. My business address is 3421 Thorn Street, San Diego, California 92104.

6 3. On September 11, 2002, I served copies of the following documents:

7 AMENDED COMPLAINT FOR PATENT INFRINGEMENT by U.S. mail, postage
8 prepaid to:

9
10 Beach Photo & Video
11 604 Main Street
12 Dayton Beach, FL 32118

13 CR Magnetics, Inc.
14 544 Axminister Drive
15 Fenton, MO 63026

16 Burrage Music Co., Inc.
17 4900 Green Road
18 Raleigh, NC 27616

19 Hobart Sales & Services
20 10905 Harrison Street
21 Omaha, NE 68128

22 All American Collectibles
23 22-08 Route 208 South
24 Fair Lawn, NJ 07410

25 American Cinema Equipment, Inc.
1927 N. Argyle Street
Portland, OR 97217

Can-Do National Tape
195 Polk Avenue
Nashville, TN 37210

Superior Recharge Systems, Inc.
2474 Manana Drive, Suite 112
Dallas, Texas 75220

1
2
3
4
5
6
7
8
9
10
11
12
13
14
15
16
17
18
19
20
21
22
23
24
25

Arcade Electronics, Inc.
5655-F General Washington Dr.
Alexandria, VA 22312

4. I declare under the penalty of perjury under the laws of the State of California that the foregoing is true and correct.

Dated this 11th day of September, 2002

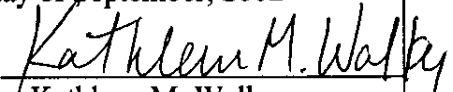
Kathleen M. Walker

United States Patent [19]

[11] **Patent Number:** **5,576,951**

Lockwood

[45] **Date of Patent:** **Nov. 19, 1996**

[54] **AUTOMATED SALES AND SERVICES SYSTEM**

4,648,037	3/1987	Valentino	364/408
4,650,977	3/1987	Couch	235/379
5,241,671	8/1993	Reed et al.	395/600
5,309,355	5/1994	Lockwood	364/401

[76] **Inventor:** Lawrence B. Lockwood, 5935 Folsom Dr., La Jolla, Calif. 92037

Primary Examiner—Donald E. McElheny, Jr.
Attorney, Agent, or Firm—Henri J. A. Charmasson; John D. Buchaca

[21] **Appl. No.:** 210,301

[22] **Filed:** Mar. 16, 1994

[57] **ABSTRACT**

Related U.S. Application Data

[63] Continuation of Ser. No. 116,654, Sep. 3, 1993, Pat. No. 5,309,355, and Ser. No. 96,610, Jul. 23, 1993, abandoned, and a continuation-in-part of Ser. No. 116,654, and Ser. No. 96,610, which is a continuation of Ser. No. 752,026, Aug. 29, 1991, abandoned, which is a continuation of Ser. No. 168,856, Mar. 16, 1988, abandoned, which is a continuation of Ser. No. 822,115, Jan. 24, 1986, abandoned, which is a continuation-in-part of Ser. No. 613,525, May 24, 1984, Pat. No. 4,567,359, said Ser. No. 116,654, is a continuation of Ser. No. 396,283, Aug. 21, 1989, abandoned, which is a continuation-in-part of Ser. No. 152,973, Feb. 8, 1988, abandoned, which is a continuation-in-part of Ser. No. 822,115.

A system for composing individualized sales presentations created from various textual and graphical information data sources to match customer profiles. The information search and retrieval paths sift through a hierarchy of data sources under multiple operating programs. The system provides the means for synergistically creating and displaying customized presentations in a convenient manner for both the customer and salesperson to achieve a more accurate, efficient and comprehensive marketing presentation. Organizational hierarchies of data sources are arranged so that an infinite number of sales presentation configurations can be created. Multiple micro-programs automatically compose the sales presentations initiated by determinants derived from customer profile information, sales agent assessment data and operator's entries including the retrieval of inter-related textual and graphical information from local and remote storage sources. A similar system can be used for filing applications with an institution from a plurality of remote sites, and for automatically processing applications in response to each applicant's qualifications. Each multimedia terminal comprises a video screen and a video memory which holds co-related image-and-sound-generating information arranged to simulate the aspect and speech of an application loan officer on the video screen. The simulated loan officer is used to acquire personal loan data from the applicant by guiding him through an interactive sequence of inquiries and answers.

[51] **Int. Cl.⁶** G06F 19/00

[52] **U.S. Cl.** 395/227; 235/381

[58] **Field of Search** 364/401, 407; 235/383, 385, 381; 395/600, 650

[56] **References Cited**

U.S. PATENT DOCUMENTS

Re. 32,115	4/1986	Lockwood et al.	235/381
3,718,906	2/1973	Lightner	
3,956,615	5/1976	Anderson et al.	
4,300,040	11/1981	Gould et al.	235/381
4,359,631	11/1982	Lockwood et al.	235/381
4,438,326	3/1984	Uchida	235/379
4,449,186	5/1984	Kelly et al.	364/407
4,567,359	1/1986	Lockwood	235/381

10 Claims, 17 Drawing Sheets

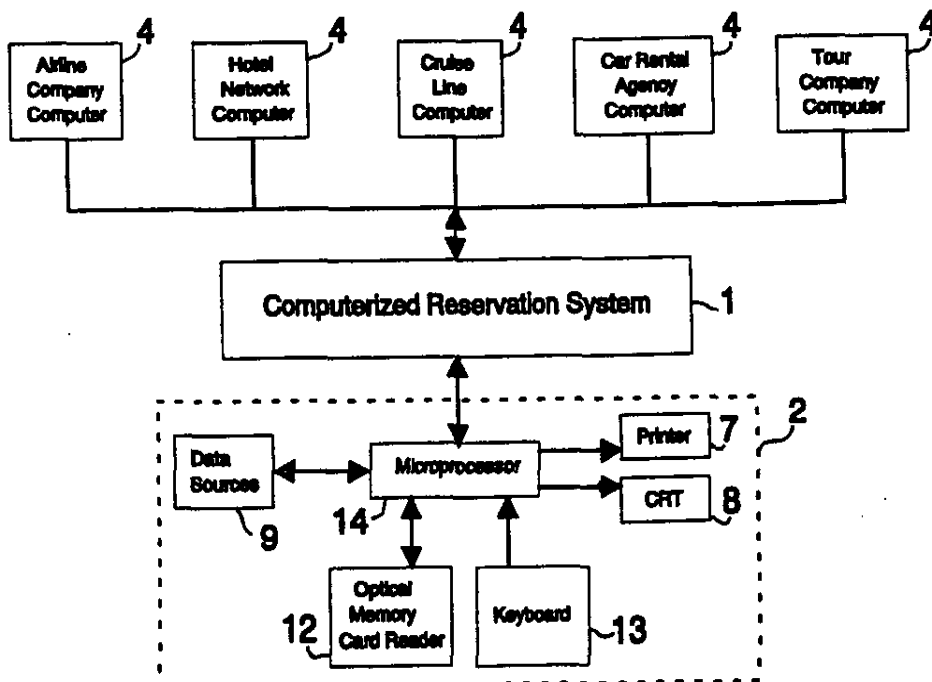

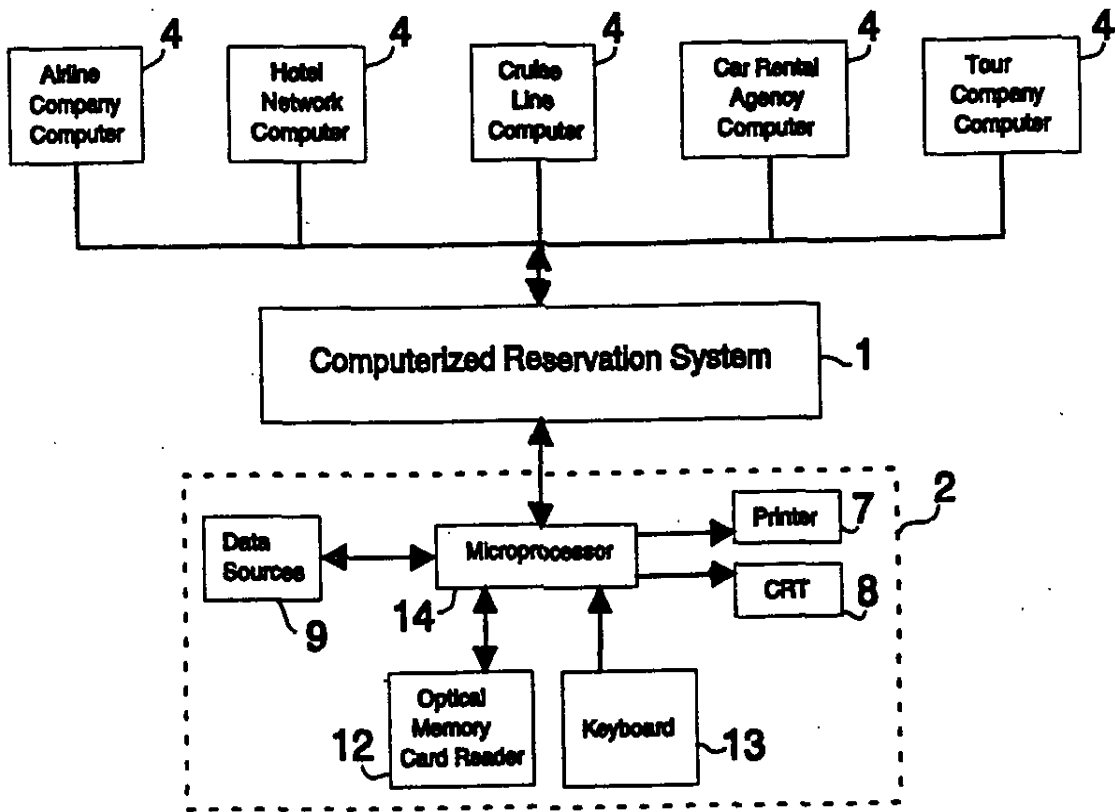

Figure 1

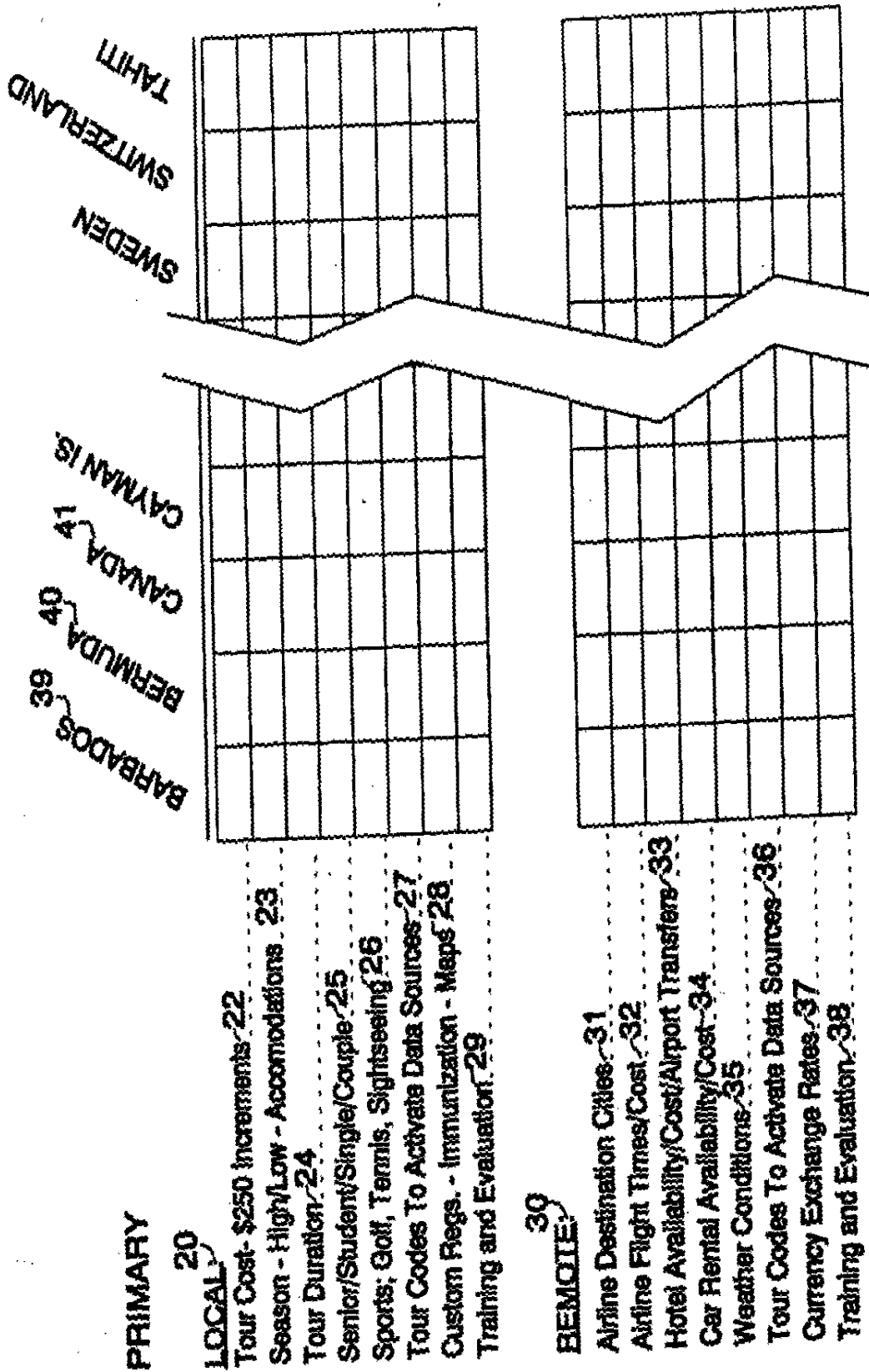

Figure 2

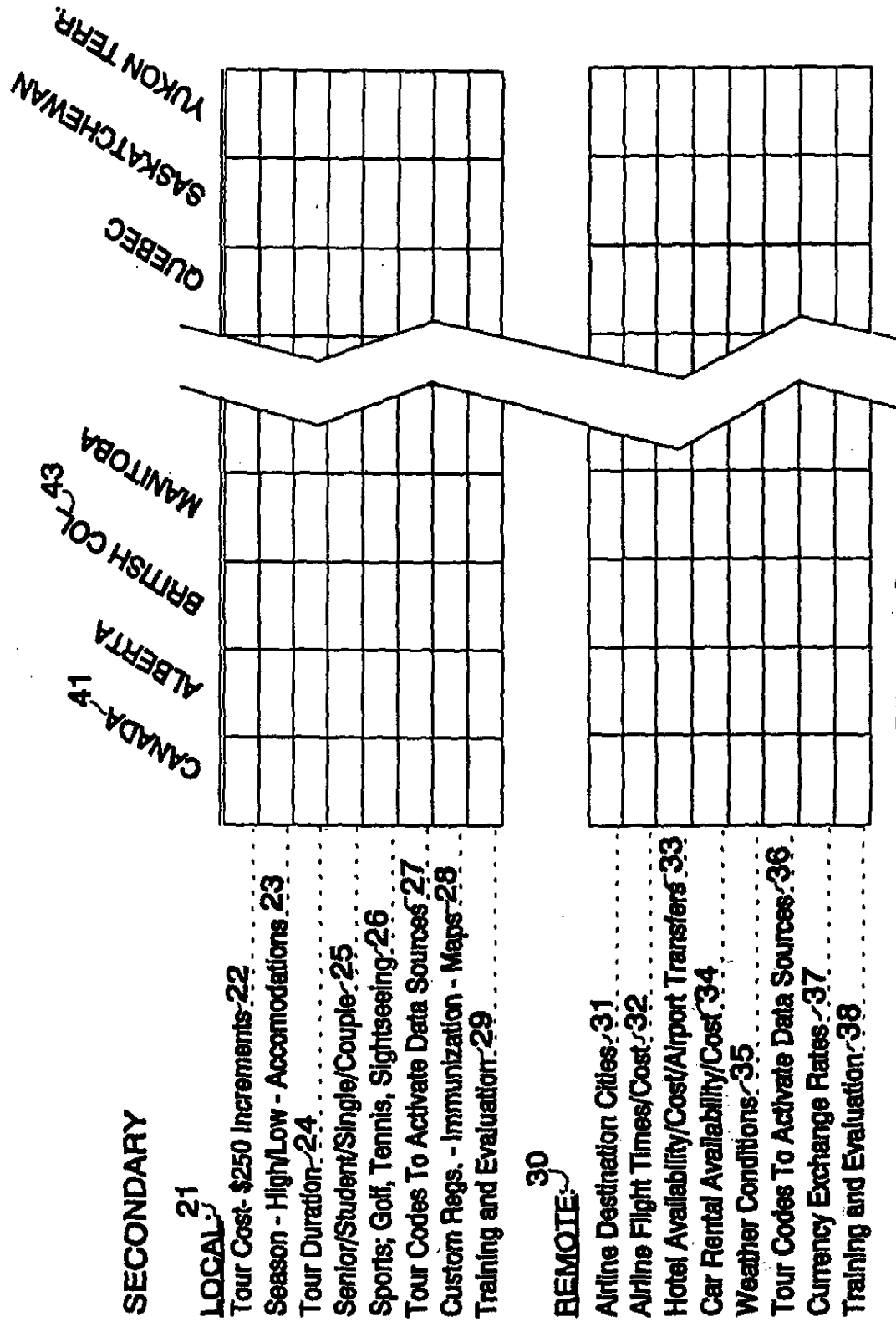

Figure 3

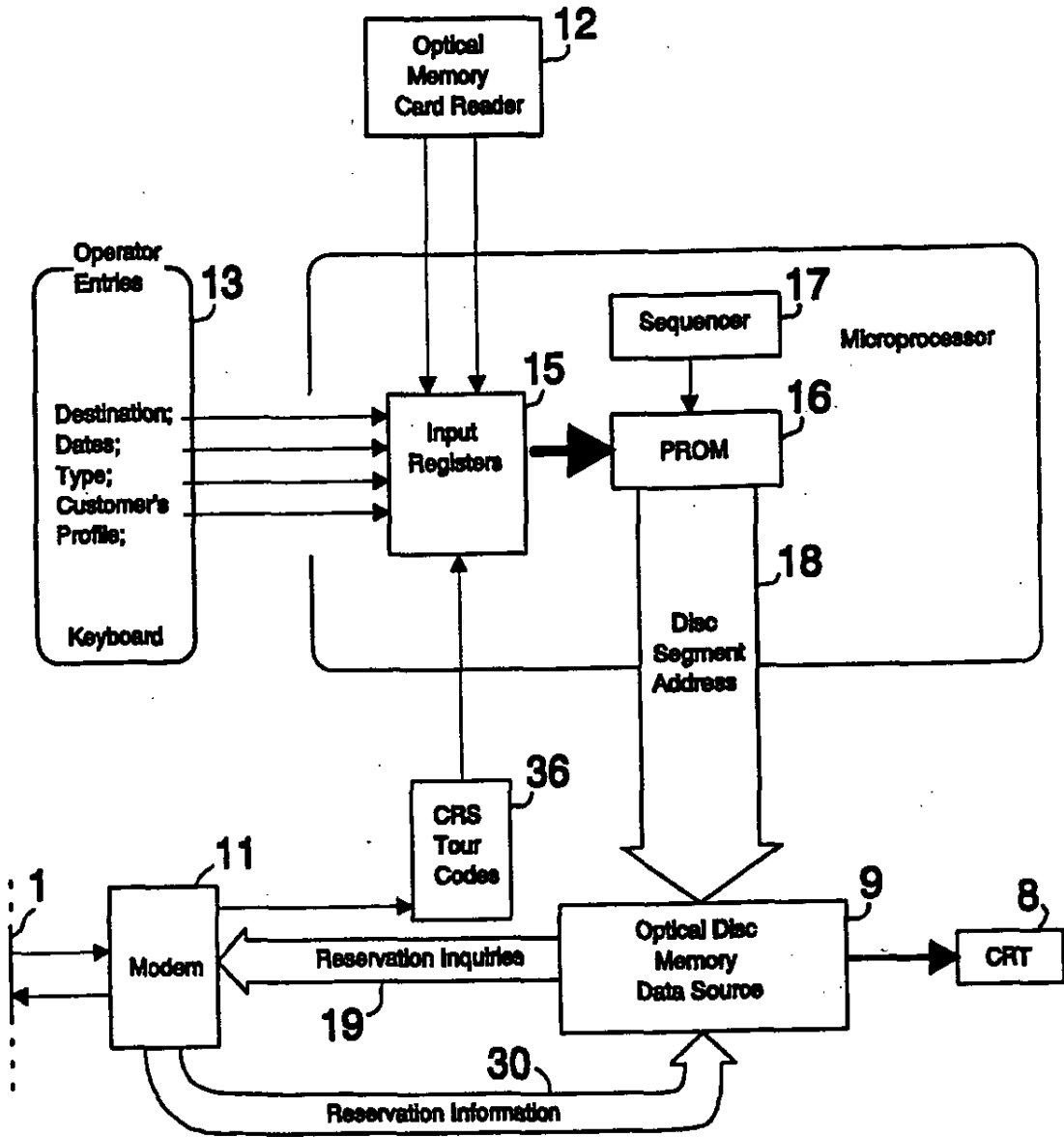

Figure 4

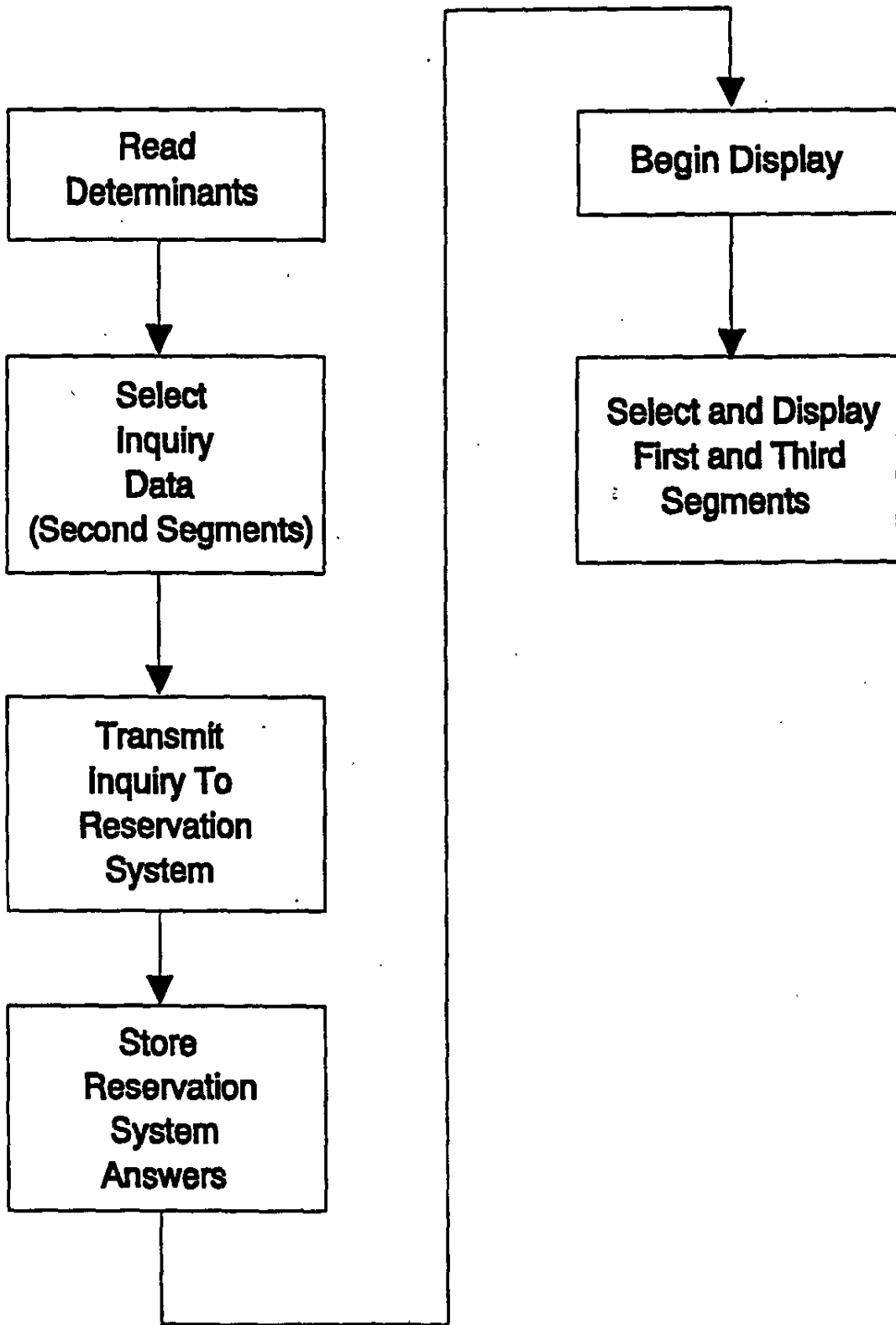

Figure 5

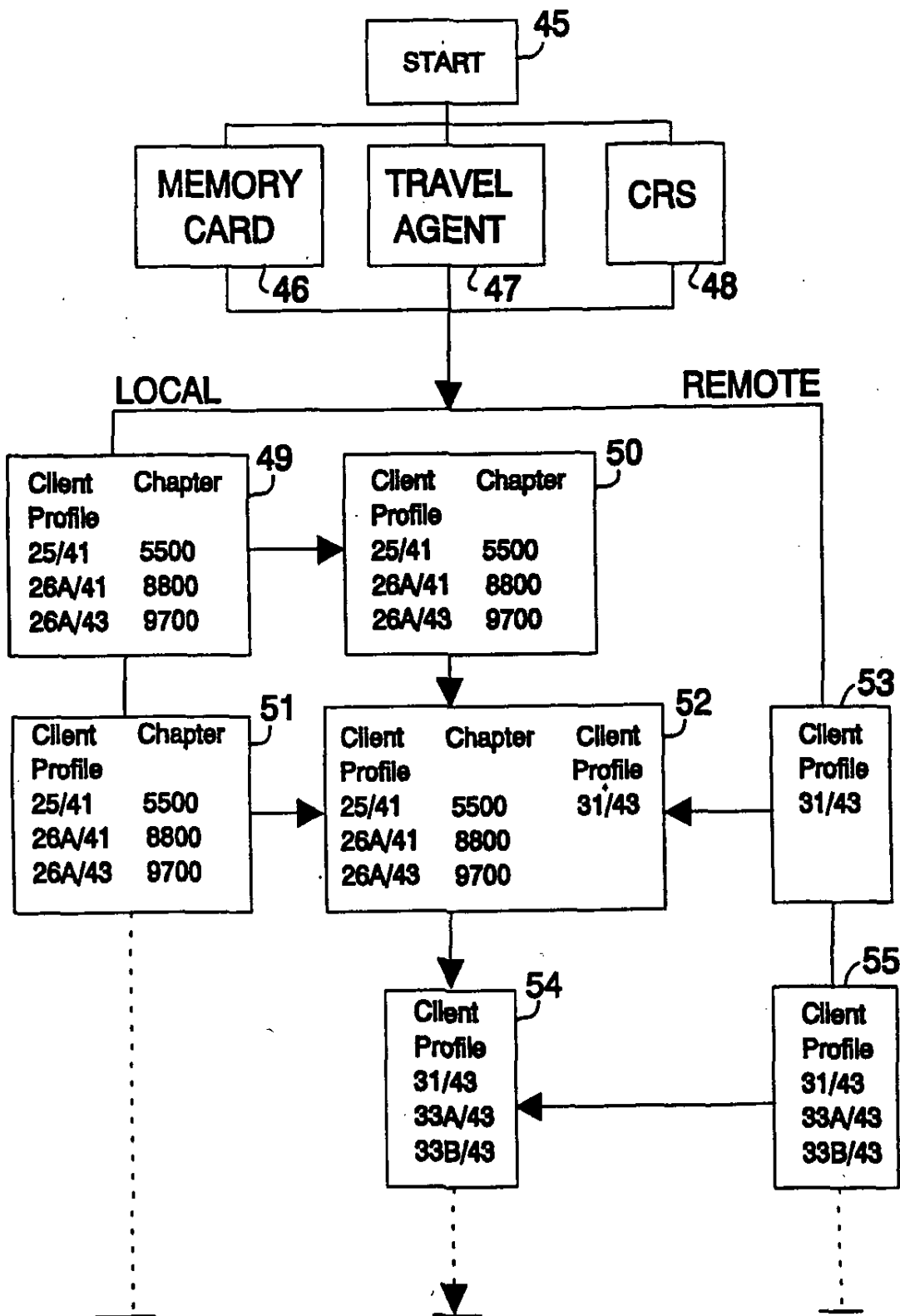

Figure 6

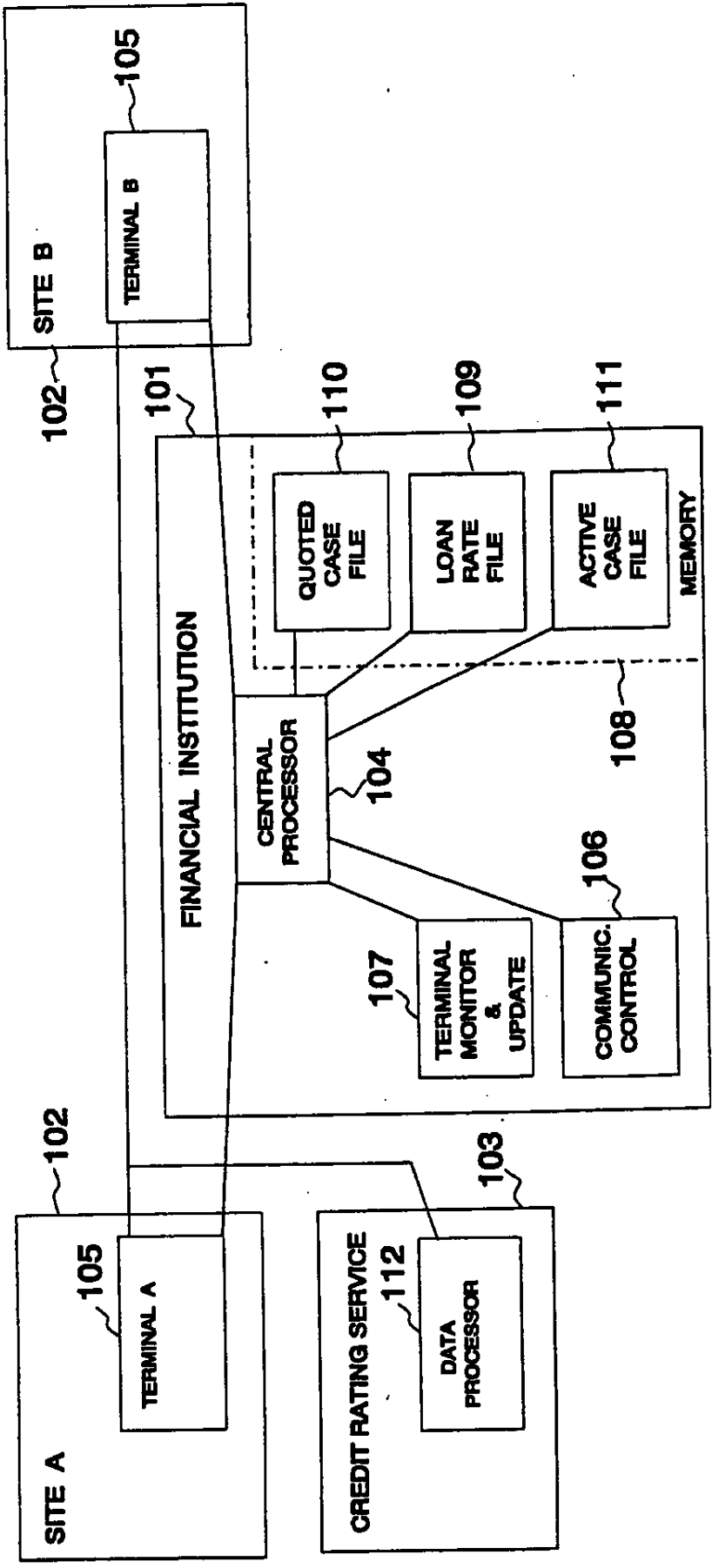

Figure 7

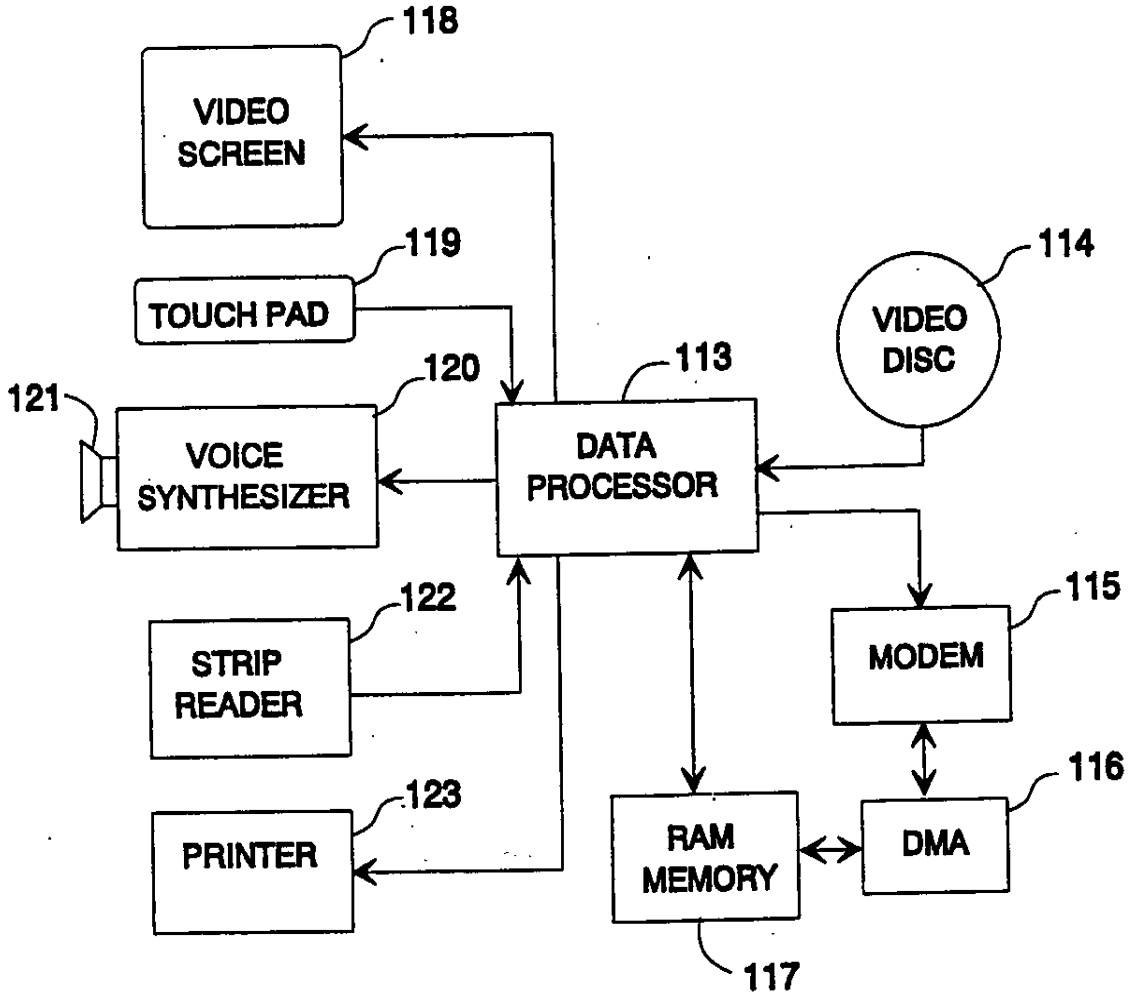

Figure 8

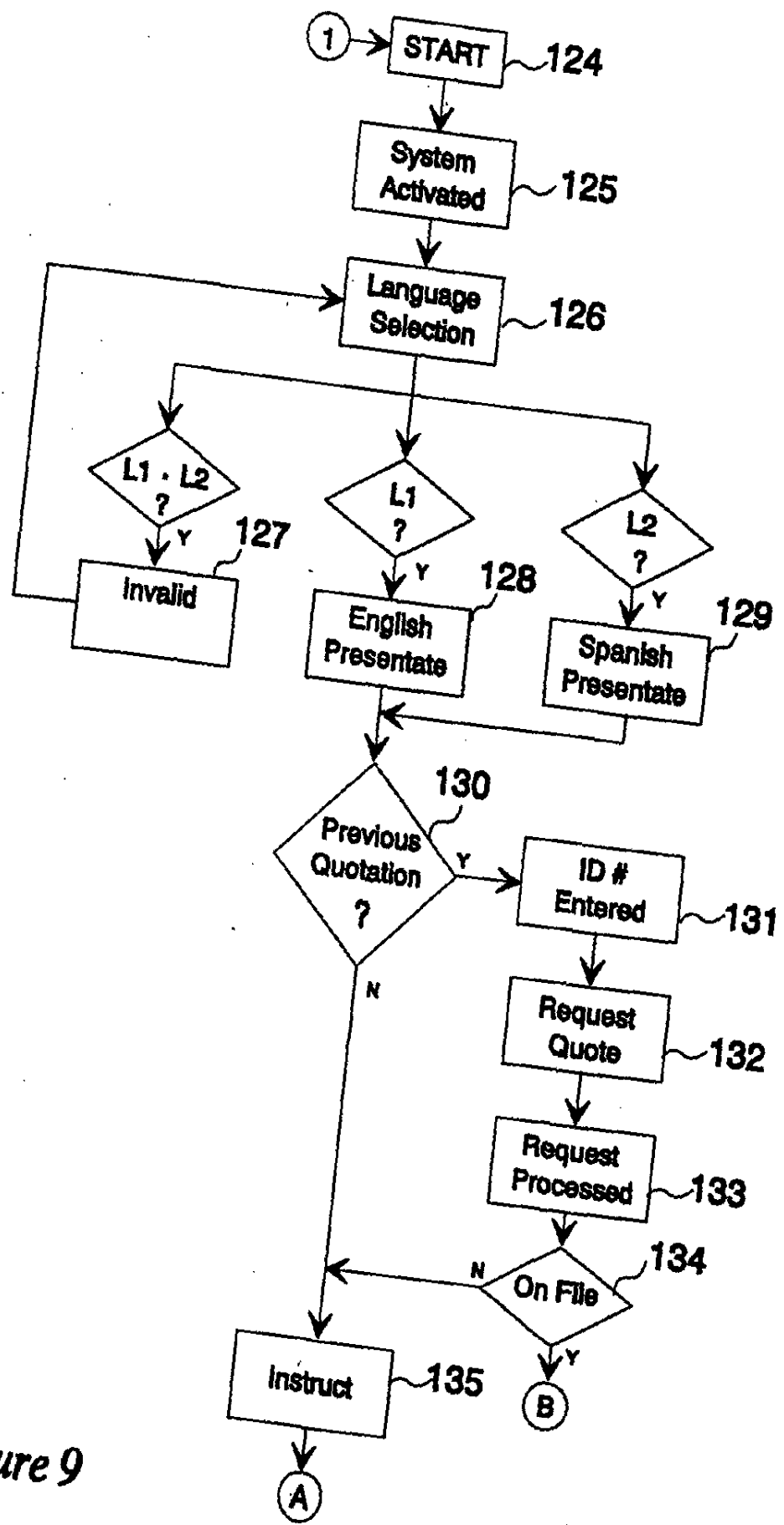

Figure 9

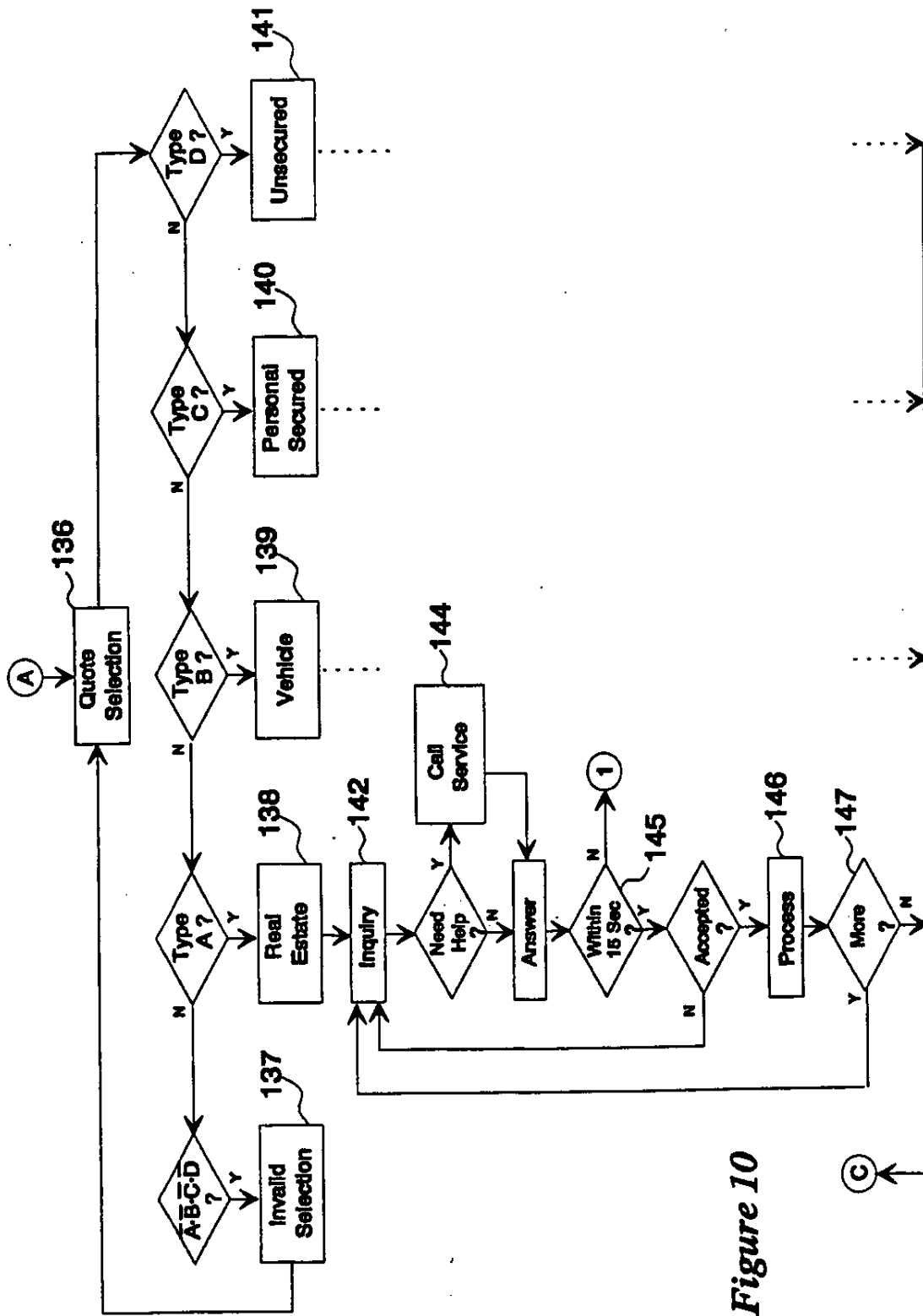

Figure 10

Nov. 19, 1996

U.S. Patent

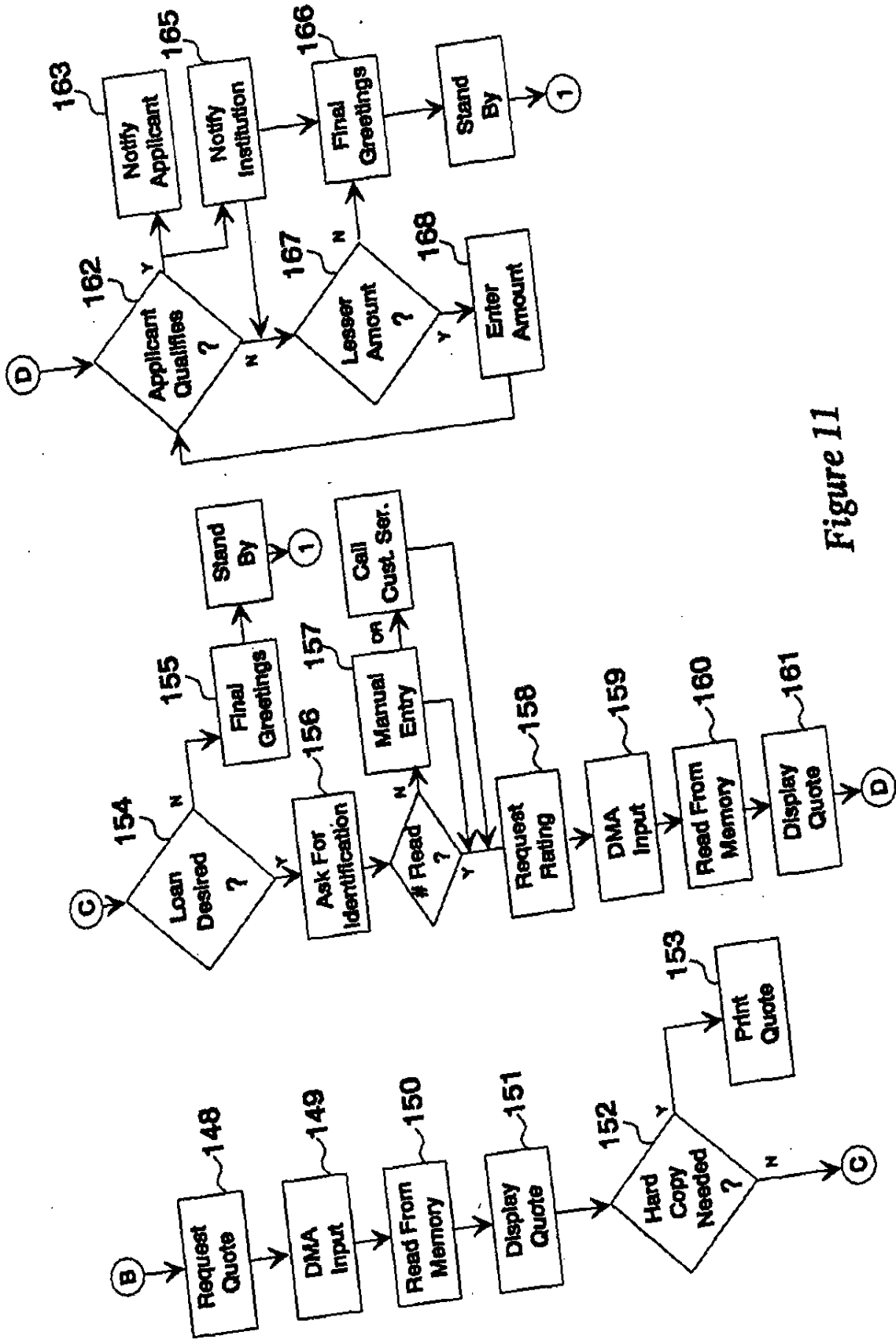

Figure 11

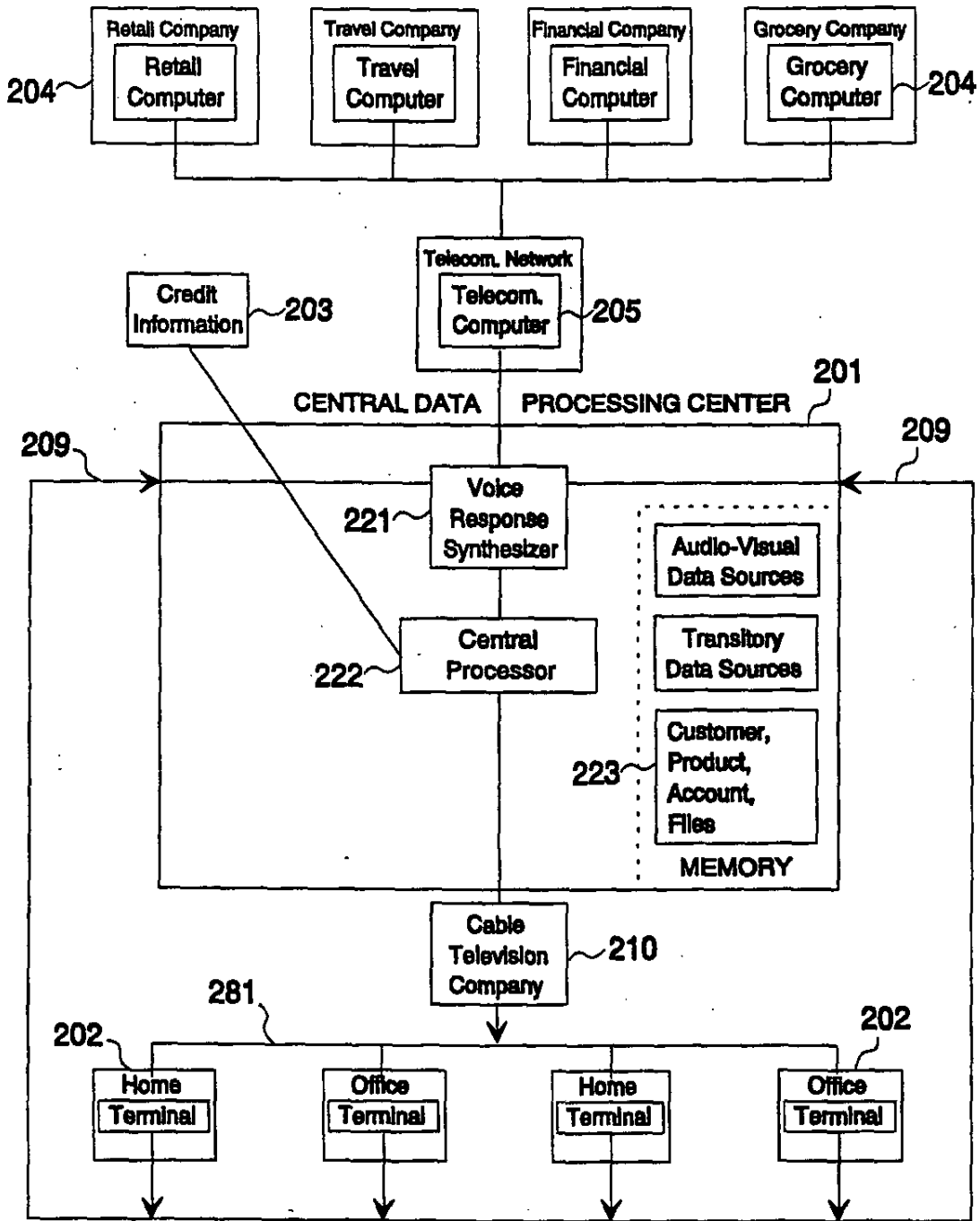

Figure 12

Figure 13

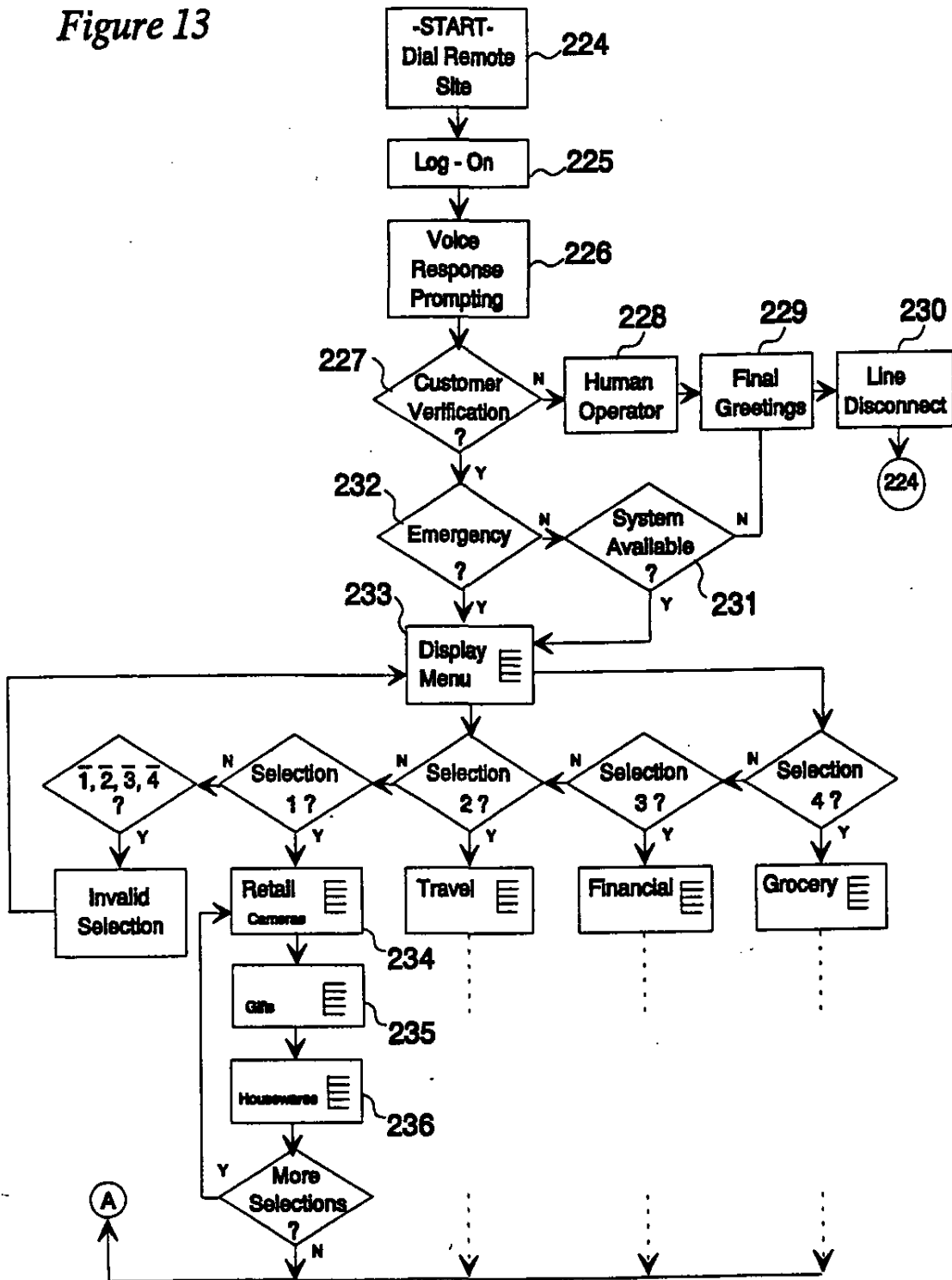
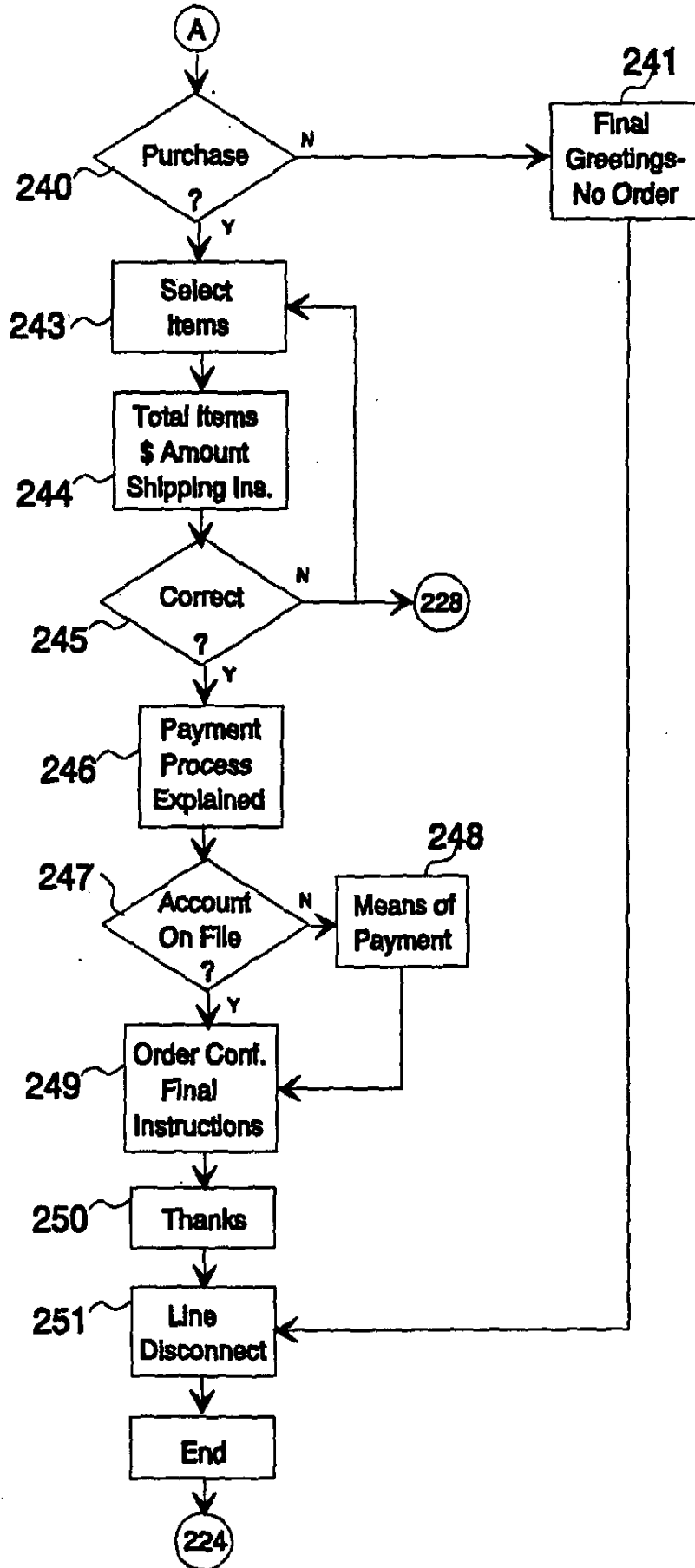

Figure 14



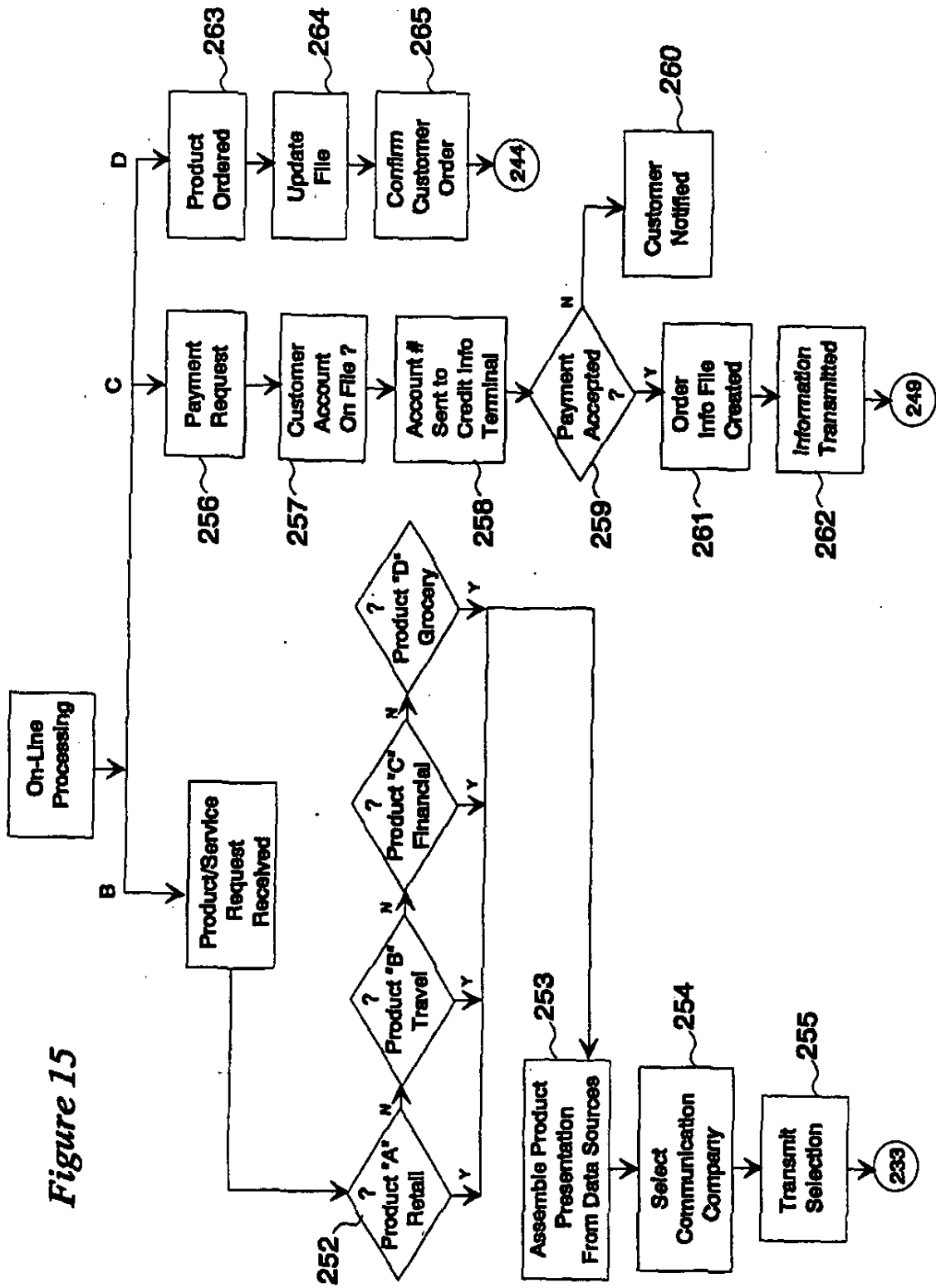

Figure 15

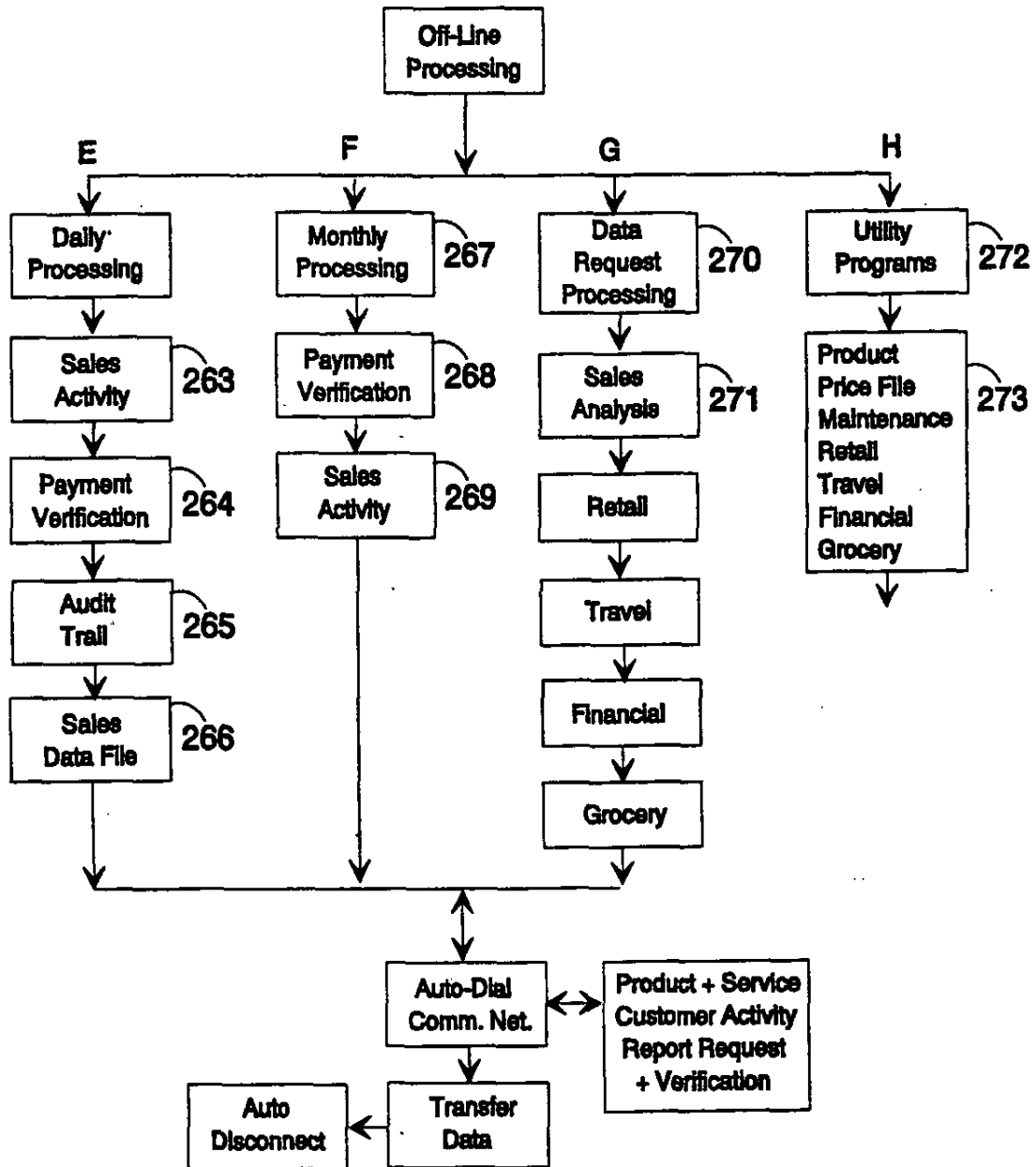

Figure 16

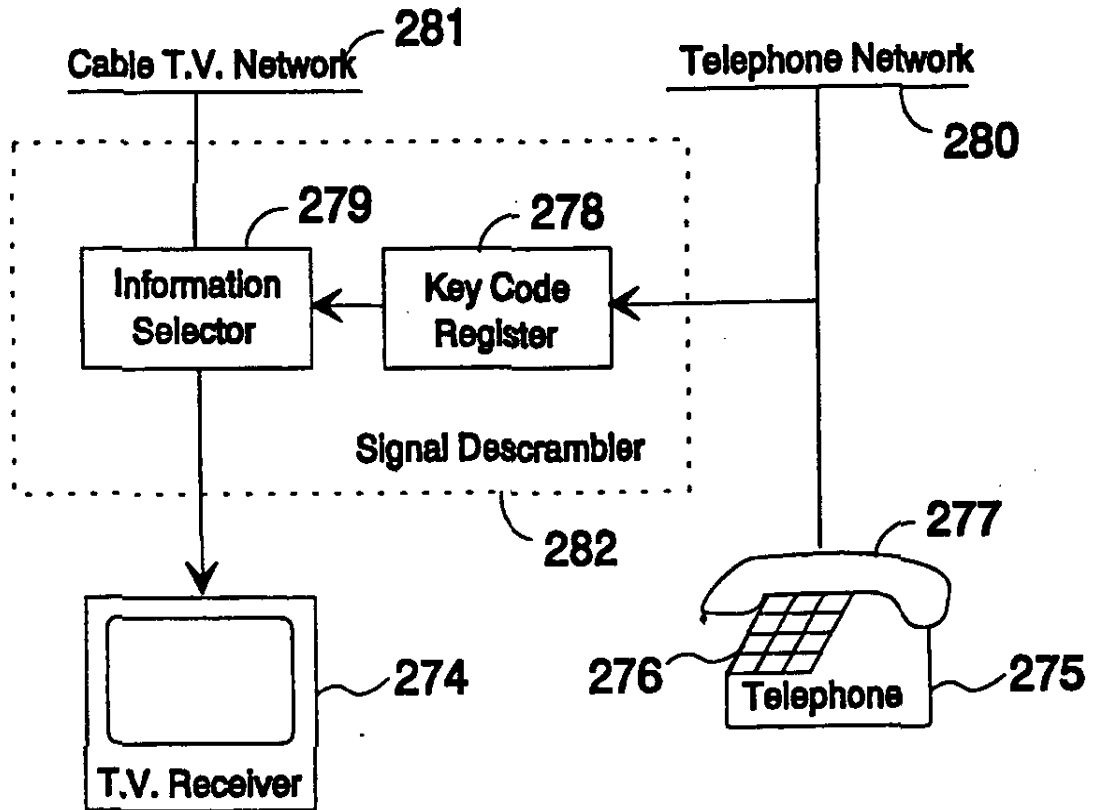

Figure 17

5,576,951

1

AUTOMATED SALES AND SERVICES SYSTEM

PRIOR APPLICATIONS

This is a continuation-in-part of application Ser. No. 08/116,654 filed Sep. 3, 1993, now U.S. Pat. No. 5,309,355 which is a continuation of abandoned application Ser. No. 07/396,283 filed Aug. 21, 1989, which is a continuation-in-part of abandoned application Ser. No. 07/152,973 filed Feb. 8, 1988, which is a continuation-in-part of abandoned application Ser. No. 822,115 filed Jan. 24, 1986, which is a continuation-in-part of application Ser. No. 613,525 filed May 24, 1984, now U.S. Pat. No. 4,567,359.

This is also a continuation-in-part of abandoned application Ser. No. 08/096,610 filed Jul. 23, 1993, which is a continuation of abandoned application Ser. No. 07/752,026 filed Aug. 29, 1991 which is a continuation of abandoned application Ser. No. 168,856 filed Mar. 16, 1988, which is a continuation of abandoned application Ser. No. 822,115 filed Jan. 24, 1986 which is a continuation-in-part of application Ser. No. 613,525, filed May 24, 1984, now U.S. Pat. No. 4,567,359.

This is also a continuation of the combination of the above-cited applications Ser. No. 08/116,654 filed Sep. 3, 1993 and Ser. No. 08/096,610 filed Jul. 23, 1993.

BACKGROUND OF THE INVENTION

This invention is directed to data processing systems designed to facilitate commercial, financial and educational transactions between multimedia terminals such as automated sales workstations, information dispensing networks and self-service banking systems. Specifically this invention is directed to a tool for augmentation of sales and marketing capabilities of travel agency personnel in conjunction with computerized airline reservation systems. This invention also relates to financial service application processing, and interactive delivery of informative, educational and recreational audio-visual programs to the home, school or office.

In the preferred embodiments of the invention, travel agents are able to synergistically compose individual customized sales presentations and itineraries for their clients, representing thousands of tour destinations and criteria, from multiple permutations of data sources in a fully automated fashion.

During the 1980s airline reservation systems evolved into very sophisticated information networks. A majority of travel agencies in North America subscribe to one of the major computerized reservation systems; Sabre, Apollo, System One, or WORLDSPAN. Prior to the development of computerized reservation systems in the 1970s, a travel agent would read airline schedules from either the North American or International edition of Official Airline Guides (OAG), printed directories which are published monthly, then telephone the specific airline to reserve and confirm passenger flights and physically write the airline tickets. The advent of computerized reservation systems allowed the travel agent to access computerized travel data banks, reserve, confirm and transact airline, hotel or car rental reservations with a 'dumb terminal' comprised of; keyboard entry of customer requirements in conjunction with a display terminal and ticket printer, connected to the centralized reservation service. The Mar. 19, 1985 testimony of Robert L. Crandall, President of American Airlines, Inc., before the Aviation Subcommittee of the Senate Committee on Com-

2

merce, Science and Transportation details the evolution of computerized reservation systems in the United States.

Travel agency employees, who produce approximately seventy-five percent of the computerized reservation systems volume, now enjoy a more productive and accurate means to process reservations, an important part of their service functions. A simultaneous sector of a travel agent's employment is the ability to promote, advise, select and sell appropriate travel and tour destinations for their clients. Agencies generate approximately fifty percent of car rental bookings, seventy percent of domestic air travel sales and ninety percent of international flights.

Travel agents sell nearly ninety percent of all cruise line bookings and virtually ninety percent of all tour packages. This business represents the most profitable segment of the multi-billion dollar travel agency sales volume, since higher commissions are earned on tour/cruise bookings as compared with point-to-point airline ticketing. The ability of a travel agent to effectively consult with their clients depends upon several factors including; knowledge of the destination, familiarization tours the agent may have taken to the area, attendance at travel/tour seminars and conferences and reading reference literature such as Fordor's travel publications.

A travel professional accumulates extensive knowledge which is extremely valuable to the travel agency business and is in fact, the single most important element which differentiates one agent from another. Unfortunately, this knowledge requires years of experience to acquire. The physical requirements to visit and inspect even a portion of popular tourist destinations dictates a significant investment of time and monetary expense. Additionally, tourist localities are seldom static; new hotels or attractions and changing custom regulations require a constant monitoring of hundreds of potential vacation sites.

The current state-of-the-art of the tour, cruise and vacation market segments is similar in many respects to the pre-computerized reservation systems airline era. A travel agent must consult several directories; i.e., Hotel and Travel Index, OAG Travel Planner, OAG Worldwide Tour Guide or OAG Worldwide Cruise and Shipline Guides and scores of travel brochures in an attempt to offer the client information for an informed travel decision. Most of these directories are published quarterly so therefore prices or schedules are frequently out-of-date and inaccurate. If the client is conferring in person, with the agent in the office, this task is complicated by the reliance on numerous publications to describe a particular vacation. This often results in a time-consuming, disorganized and ineffective sales presentation since each client's itinerary has different requirements. Answering a client's questions is dependent upon the knowledge a travel agent has acquired. Since 'travel' is an intangible product, the communicative skills of the travel agent are paramount to success. The client relies on the travel agent's advice in making important vacation decisions.

Several specialized tour planning concepts emerged in the 1970s including publications such as Fishing Resorts of The World, which presented sportfishing tour packages in an organized and informative manner and audio-visual presentations of tour destinations such as TRAVEL-VISION which were linear in design. These travel marketing concepts, both created by applicant, had inherent limitations as discussed herein.

The travel industry, comprising 33,000 agencies, does not sell a single mass market product, but rather is a reflection of the population as a whole with its infinite individual

5,576,951

3

customer profiles of demographic, regional and fields of special interest. One client may desire information on a river-rafting tour in Wyoming while the next customer needs assistance in planning an art tour of Paris, France. Therefore, it is imperative that the travel agent have available a wide variety of information in an organized system which allows convenient and standardized access for both the agent and client.

A recent study of the American labor force, Work Force 2000: Work and Workers for the Twenty-first Century, commissioned by the United States Department of Labor, indicates serious shortages of skilled workers in the service sector economy will impact the United States during the 1990's and into the next century. In addition to labor shortages in many skilled service sector industries, it is predicted that a mismatch of employee skills to available jobs will result in a shrinking labor pool of skilled workers which will inevitably increase wages. Travel agency functions are predominantly labor intensive, therefore labor shortages of skilled workers will significantly impact the quality of service they provide.

All travel agencies essentially market the same products and represent the same suppliers, therefore as a service sector industry it is incumbent that individual sales skills and support systems be as comprehensive and efficient as possible. Since the travel industry is highly dependent upon knowledgeable professionals, requiring years of experience, it portends that a more efficient travel/tour sales and training system be implemented to compensate and increase the productivity of the travel agent.

Thus, there is a continuing need to provide the means to assist travel agency personnel and their clients with a more responsive and efficient; educational, training, sales and service system.

A first alternate embodiment of the invention relates to multimedia terminals used by banking institutions to make their services, such as loan processing, available at all hours of the day from various remote locations.

Loan processing has traditionally been a labor-intensive business which represents the major activity of banks and other financial institutions. In the processing of a loan application, numerous forms have to be filled-out, loan officers have to explain payment schedules and generally guide the applicant through the loan application process. The financial institution then has to process the application and either telephone, mail, or communicate acceptance or rejection of the loan in person to the applicant. The complexity of the process has so far prevented the application of automatic terminals to perform this important part of financial institution activities. Interactive multimedia terminals have evolved to a high degree of sophistication as disclosed in U.S. Pat. No. 4,359,631 Lockwood, et al. Yet, this high degree of sophistication has not been put to use in the more complex types of goods and services distribution which require a great deal of interaction between individuals and institutions.

A second alternate embodiment of the invention relates to an improvement of a system for automatically dispensing information, products and services by means of stored prerecorded audio-visual presentations telegenically transmitted from a remote site to sales and information terminals in the home under the command of customers with easy-to-use communication equipment that does not require formal computer literate training.

Service providers have traditionally communicated and marketed information and products to consumers in their

4

homes by way of newspapers, magazines, mail order catalogs, direct mail, telephone, radio and television. None of these communication methods allow consumers to interactively display alternate audio-visual sales presentations for transactional order fulfillment. Lately, videotex has emerged as a supplement to traditional product ordering methods. Beginning in 1978, British Telecom established a videotex service named 'Prestel' planned for a mass consumer market. Videotex, a textual display, is not designed nor intended to deliver full color prerecorded audio-visual presentations. Videotex typically requires computer operating knowledge and a personal computer with modem for access. Subsequently several major attempts at introducing videotex in North America have failed and surviving operators have maintained a limited user base. A fundamental reason for the unsuccessful acceptance of videotex is that it requires reading of computer generated text. Conversely, the American consumer has become accustomed to a high degree of television quality programming from sporting events and news to popular movies broadcasted daily.

Interactive delivery of information, goods and services to consumers by means of multimedia terminals is disclosed in U.S. Pat. Nos. 4,359,631 and 4,567,359 using a central processor, audio-visual data sources, CRT, keyboard and remote communication capabilities.

It would be desirable to provide such a system accessible to consumers from their homes or workplace.

Typically consumers have had to travel to multiple stores and shop for products. This is both time-consuming and involves transportation expenses. Certain segments of the population, for example disabled persons and the elderly have been restricted in their ability to compare product features and prices. The system could also allow service suppliers and product manufacturers to communicate directly with consumers and present products, take orders and ship purchases from a central or regional warehouse facility. This would reduce the expense of maintaining retail stores, inventory, sales personnel, overhead and general distribution costs while providing services to hundreds or thousands of homes and offices throughout a community.

Preferably such a system would incorporate; a central data processing center, audio-visual data sources, a CRT for displaying information, communication links and a keyboard for control of the remote data sources. Additionally, such a system would allow consumers an opportunity to communicate with product and service providers to place orders, and to process commercial transactions.

Interactive audio-visual communication systems using television and telephone common carrier networks are now possible based on some of the techniques disclosed in U.S. Pat. Nos. 3,668,307 Face et al., 3,691,295 Fisk, 3,746,780 Stetten et al., 3,752,908 Boenke et al., 4,054,911 Fletcher et al., 4,064,490 Nagel, 4,251,691 Kakihara et al., 4,264,925 Freeman et al., and 4,553,222 Kurland et al.

Research reveals that the average person retains about 25 percent of what they hear and 45 percent of what they see and hear. Retention levels increase dramatically to 70 percent of what a person sees, hears and performs if an interactive sequence is available. Therefore the persuasive power of interactive full color multimedia presentations would be an ideal means to market products and services. This in-home information delivery system could also provide a conduit for educational, medical and other important informational services.

SUMMARY OF THE INVENTION

Accordingly, the objects of this invention, among others are to:

5,576,951

5

enhance the travel agent's sales ability and professional knowledge of travel and tour destinations in conjunction with computerized reservation systems;
 create a flexible travel sales system responsive to multiple applications and configurations;
 organize a variety of traditional travel and tour references in a comprehensive and synergistic multimedia sales system to effectuate consumer awareness;
 increase the sales productivity and information accuracy of vacation tour packages sold by travel agents;
 develop individualized tour planning programs for clients presented in a more effective communication's medium;
 reduce travel agent dependency on outdated travel directories, tour manuals and traditional brochures;
 provide a consistent in-house teaching and training system for travel agency personnel; and
 offer travel suppliers and tour operators an enhanced and efficient means to present their products and to communicate with potential customers when selecting vacation destinations.

These and other objects are achieved by the preferred embodiment of the invention which is directed to a means for automatically creating and displaying customized travel and tour sales presentations from various textual and graphical data sources managed by a multiplicity of operating programs. Sales presentations comprise audio-visual data and computerized reservation system information, presented individually or in combination. The graphical data may include charts, maps and other still images as well as moving pictures with or without sound enhancements.

Individualized sales presentations are requested by the client for specific destinations. The organizational hierarchy of data sources is arranged so that an infinite number of variations or sales presentation configurations can be displayed. Multiple operating programs create the sales presentations directed by:

- (1) Client profiles stored on optical memory or smart cards;
- (2) Travel agent assessment of client profiles; or
- (3) Computerized reservation system response to client profiles.

The travel agent interviews the client and determines the general information required for accessing the sales system and enters the prerequisites such as; destination, tour costs, sports activities, accommodations and other factors necessary for generation of customized mini-travelogues. The selected factors are analyzed by the operating program based upon an organizational hierarchy of travel specifications which activates the data sources and a customized sequence is presented. Sales presentations can be accessed interactively, one display frame at a time with a decision point at each juncture, or by analysis of the client's profile which generates a coded operating program sequence to display a continuous customized presentation. Additionally, a combination of either interactive or coded program modalities can be presented. A client may wish to preview a destination in an interactive search sequence and upon deciding that the tourist destination is in fact the one he desires, could proceed with an operating program from the input of client characteristics. This alternating procedure allows greater comprehension and sales flexibility.

Operating programs select the presentation chapter segments from either the audio-visual data source repository or the computerized reservation system and arrange them in an

6

orderly and predetermined sequence. The sales presentations incorporate proven 'need satisfaction selling' including: probing, supporting and closing techniques. This assures a maximum sales effort on behalf of the travel industry. Clients are both creators and viewers of the mini-travelogues which are specifically addressing their needs while simultaneously assisting the travel agent in a comprehensive sales effort.

As explained in the first alternate embodiment, another object of the invention is to standardize the reporting and interpretation of credit ratings and their applicability to loan application processing.

A further object of the invention is to reduce the amount of paperwork and processing time required by each loan application.

It is also an object of the invention to offer a more personal way to apply for credit. Many applicants are reluctant to inquire about loans requiring face-to-face interaction with a loan officer, who would not hesitate to use an interactive device to place their inquiry.

These and other objectives are achieved by means of a system that connects financial institution data processing, the computer services of a credit reporting bureau, and a plurality of remote terminals. Each remote terminal displays the live image of a fictitious loan officer who helps the applicant through the interactive series of questions and answers designed to solicit from the applicant all the information necessary to process his loan application. The terminal can acquire credit rating information about the applicant from the credit reporting bureau and make a decision based on all the information gathered about the credit worthiness of the applicant and the amount of loan to which he is entitled. The amount is then communicated to the applicant and to the financial institution for further processing of the loan.

As explained in the second alternate embodiment, additional objects of the instant invention comprise among others, the following:

to provide an automatic and efficient system for dispensing information and services to the general public interactively from terminals in their homes;

to offer such a system which is particularly useful for dispensing information, goods and services for a wide variety of service industries;

to facilitate immediate access to thousands of products and services by the elderly, disabled persons and others limited by travel or time constraints;

to present such services by means of audio-visual presentations for transactional decisions from prerecorded sound, images and synthesized data;

to centralize product distribution, therefore reducing traditional merchandising overhead costs while increasing manufacturer's product selection, target marketing and advertising promotion of products;

to increase service sector productivity while reducing inventories and out-of-stocks by creating an unlimited number of distribution outlets over geographically extended trade areas which operate 24 hours per day;

to maximize information delivery by interactively involving the customer as opposed to passive viewing.

In furtherance of these additional objects, an automatic system is disclosed for dispensing information, goods and services to consumers in their home. The system comprises a central data processing computer and multiple remote satellite facilities linked to the center. The satellite facilities are sales and information terminals, each equipped with a CRT (Cathode Ray Tube) for receiving and displaying

5,576,951

7

requested customer information from the computer's data sources at the data processing center. Customers interactively display the audio-visual presentations by selecting various choices and entering the choices on a telephone keypad which directs the computer to select from its data sources the requested information and transmit it to the customer's CRT in their home.

The system operates in the following sequence:

1. The customer dials the data processing center and requests access to the system.

2. The data processing center verifies the customer and selects from its data sources the general instructional audio-visual presentation which is routed through the customer's local cable television communication link and transmitted to the customer's sales and informational terminal.

3. The customer views the presentation and selects from the menu presented on the screen the next display.

4. The customer enters on the telephone keypad the selection which is transmitted to the data processing center via the telephone communication link.

5. If the customer decides to purchase a product or service he also enters on the keypad the payment information.

6. After verification and acceptance of the payment, a confirmation message is displayed on the customer's CRT video screen.

7. Information on the transaction is transmitted from the data processing center to the relevant product or service company for fulfillment.

This second alternate embodiment of the invention is directed to a system for automatically dispensing information, goods and services from multiple retailers, and from travel, financial, and other service providers. The data processing center is linked to data sources of various product and service providers for order processing. The data processing center is programmed to respond to customer's directions, select requested audio-visual presentations from its data sources of prerecorded information segments and place them on a television network from where they will be decoded, captured and displayed by the customer's home receiver.

If the customer elects to purchase a product or service, his order is processed by the data processing center. After validation and acceptance, confirmation of the order is displayed on their CRT monitor.

The data processing center stores information about the products and services offered by each supplier, and tabulates sales. The data processing center is programmed to transmit periodically to each institution's data processing terminal, either directly or indirectly, for example through an automated telecommunication network service such as TELENET®; up-dated information on sales made by the system for that institution.

Suitable data links, such as phone line, cable television and optical fiber data links can be used between the sales and information terminals and the data processing center, and between the service provider's data processing terminals, either directly or indirectly via common carriers. In the latter case, each institution will have its own particular account number with the service to which information on sales made by the system will be delivered. Similarly, the system itself will have an account number to which each institution can deliver information on any changes in prices or services offered.

The data processing center is suitably also linked to a remote credit information center for checking the credit of a customer in response to a sales order and charging a customer's account via debit card, credit card or alternately

8

customer accounts that are also stored at the data processing center for monthly billing.

BRIEF DESCRIPTION OF THE DRAWINGS

FIG. 1 represents a general block diagram of the overall system for creating customized travel sales presentations of the preferred embodiment of the invention;

FIGS. 2 and 3 represent organizational charts of travel sales presentations from multiple data sources;

FIG. 4 is a block diagram of the sales presentation organization and display operation;

FIG. 5 is a flow diagram of the information selection and display process;

FIG. 6 is a flow diagram of a detailed information selection process;

FIG. 7 is a general block diagram of the system for automatically processing loan applications according to the first alternate embodiment of the invention;

FIG. 8 is a block diagram showing the major components of the terminal;

FIGS. 9 to 11 are detailed flow diagrams of the system operation.

FIG. 12 is a general block diagram showing an overview of a system for automatically dispensing information, goods and services according to the second alternate embodiment of the invention;

FIGS. 13 to 16 are detailed flow diagrams of the system; and

FIG. 17 is a functional block diagram of a home or office station.

DESCRIPTION OF THE PREFERRED EMBODIMENTS OF THE INVENTION

FIG. 1 represents a general block diagram of the overall system for creating customized travel sales presentations according to the preferred embodiment of the invention. It will be understood that such a system may be used in a variety of other service-oriented industries, such as retail sales and real estate, various financial services and the like.

The system basically comprises one or more special information and sales terminals 2 linked to an airline computerized reservation system 1 which gives access to the data processing installations of various travel suppliers 4. The terminals are all linked to the computerized reservation system by any suitable remote telecommunication links. This automated travel and tour sales system is preferably achieved according to the teaching of U.S. Pat. Nos. Re. 32,115 and 4,567,359 whose specifications are hereby incorporated herein by this reference.

The information and sales terminals 2 include one or more audio-visual data sources 9. These resident data sources are preferably optical disc based with the capabilities for generation of full motion, still-frame, audio compression and related functions to achieve random access audio-visual presentations directed by a microprocessor 14. Data sources 9 may suitably be implemented with a SONY View System brand of videodisc recorder model VIW-5000 and SONY 650 MB cartridge or a CD-ROM player. Various combinations of interactive audio-visual system technology such as CD-ROM, CD-I or DVI may be incorporated to effectuate the travel presentations. The microprocessor 14 is suitably an IBM PS/2 brand of personal computer. The optical memory card reader 12 is of the type disclosed in U.S. Pat.

5,576,951

9

Nos. 4,284,716; 4,542,288; and 4,544,835. The printer 7, CRT 8 and keyboard 13 are standard devices and the interfacing of the various components are well-known to those skilled in the data processing arts.

Organizational chart FIG. 2 describes audio-visual chapter segments organized in topics and subtopics which constitute the tour information and which are identifiable and accessible by frame numbers. A standard videodisc contains 54,000 individual frames or 30 minutes of full motion video which can be accessed randomly. The construction of individualized tour package presentations by frame numbers is managed by the program of the microprocessor 14 as will be explained below. The travel agent enters the client's requests and characteristics to initiate the travel presentations. Each numbered chapter segment contains a transition bridge, so that presentations are not abrupt but rather form a continuous, harmonious dialogue with the client composed in a progressive predetermined format to increase sales effectiveness, for example; country, region, city, hotel and sight-seeing. Training and evaluation 29 would typically consist of instructional information which would be presented in the form of lessons.

REMOTE 30 represents textual information which is accessed from the computerized reservation system 1. This information; airline flight times 32 and hotel availability 33 is critical to the tour sales presentation if transportation or lodging is required. Therefore, LOCAL 20, and REMOTE 30 act in conjunction to present an integrated and individualized travel and tour sales travelogue. REMOTE 30 creates dynamic presentations of transitory information such as weather conditions 35 or currency exchange rates 37.

REMOTE 30 can transmit tour codes to activate data sources 36 to information and sales terminal 2. This allows the organization of timely vacation tours in the travel agency. In this manner 'special' tours with limited reservation deadlines can be promoted that otherwise could not be marketed in traditional printed brochures.

It will be understood that optimal sales presentation effectiveness is determined by the attention span of the client. Therefore, program design parameters of the mini-travelogues include specific time limitations dependent upon client characteristics. Training and evaluation 38 offer an enhanced instructional program which can also transmit codes to the microprocessor-accessed data sources 9 in concert with transitory information from the computerized reservation system 1 to train and test travel agent proficiency presented on CRT 8.

Organizational chart FIG. 3 describes a secondary selection format which further delineates tourist destinations in multiple subsets. If the client selected Canada 41, the microprocessor would define a Canadian province such as British Columbia 43 as a function of the client's characteristics. Additional organizational A1 format can define cities within the selected province and then tourist features within cities.

FIG. 4 illustrates the selection process for the various segments of the sales presentation. The basic selection data which is either entered on the keyboard 13 by the operator or read by the memory card reader 12 are loaded into the input registers 15 of the microprocessor 14. This basic selection data includes the type of service requested (such as ski weekend, cruise, or camping trip), the approximate date of departure and return, the destination and customer characteristics such as age, gender and preferences. This information serves as addresses for a programmable read only memory (PROM) 16 or other similar device which is driven

10

by a sequencer 17 to deliver a series of specific disc segment addresses 18 or pathways for the videodisc memory data source 9. Some of the addressed segments on the videodisc correspond to inquiries 19 which are sent via a modem 11 to the airline reservation system 1. The answers, mostly reservation information 30, when received, are presented on a split-screen or recorded on the erasable optical disc or other suitable medium for display as part of the sales presentation on the CRT 8.

Three types of randomly accessible segments of data are thus stored in the data source 9, the audio-visually displayable narrative chapters, the inquiries to be sent to the reservation system and the essentially textual reservation systems answers to be combined with the narrative chapters.

Thus, the programming of the entire sales presentation resides in the programming of information access paths in the PROM 16. In other words, the PROM assist the user in his quest by performing automatically and almost instantly, the sequential and time-consuming information accessing, gathering and organization that a travel agent must process using conventional reservation and information sources.

FIG. 5 illustrates the general selection and display process done under instructions issuing from the PROM 16 based on the determinants stored in the input registers 15 under control of the sequencer 17. It should be noted that the first segment of narrative data are the only ones that need to be coded for video display. The second segments are binary coded inquiries to be sent via the modem 11 to the reservation system 1. The answers received from the reservation system are times and prices information which are displayed in alphanumeric form usually in a tabular format which does not require to be translated into variable-gray-scale-video signals, nor any graphic display encoding.

The determinants stored in the register 15 provide an address to the PROM 16 corresponding to a set of instructions. Those instructions are sequentially extracted by the sequencer 17 to trigger the various selection and display steps.

Data sources 9 typically include a videodisc which contains time codes indicating each video frame by hour, minutes, seconds and frame number or picture, chapter or still cue code inserted in the vertical interval of the videodisc which is read by the videodisc player. A frame is a single, complete picture in a video or film recording. A video frame consists of two interlaced fields of either 525 lines running at 30 frames per second (NTSC) or 625 lines at 25 fps (PAL/SECAM). The address is usually an alphanumeric or numeric label identifying a location where information is stored on the videodisc or a time code or frame number identifying the location of video and/or audio material on the optical disc.

A chapter is an independent, self-contained segment of an interactive video program. Chapter number codes are numbers also encoded in the vertical interval of the videodisc frame, allowing chapter numbers to be displayed on the screen during play. Chapter search is a function of most videodisc players allowing specific chapters to be accessed by chapter number or to request a specific frame identified by its unique sequential reference number, which then instructs the videodisc player to move directly forward or backward to that frame from any other point on the videodisc. Chapter stop is a code embedded in videodiscs to signal the break between two separate chapters, allowing specific chapters to be accessed using chapter search. A standard videodisc contains 54,000 individual frames.

Proceeding now to FIG. 6 which is a detailed flow diagram of the implementation of the address matrix to

5,576,951

11

compose three sales presentation displays; LOCAL, LOCAL/REMOTE and REMOTE. The program selection is initiated 45 with activation of client's prerequisites from memory card 46, travel agent assessment 47 or by receipt of tour codes from the computerized reservation system in response to client's profile 48. The selection determinants as described in organizational hierarchies FIGS. 2 and 3 depict specific chapter segments which when assembled would constitute an individualized sales presentation.

For example, a typical sales presentation for selecting hotel accommodations 23 which would include displaying pictorial representations of hotels i.e., overview, rooms, restaurants, sporting facilities, swimming pools, and tennis courts. Applicable textual travel information such as Canadian custom and immunization 28 regulations correlatively stored with the hotels information would be displayed textually. This textual information would be backed by maps of the area.

In FIG. 2, if client selects Senior 25 the chapter identity subset numbers would be; Senior/Barbados 25/39 chapter 5100, Senior/Bermuda 25/40 chapter 5300, Senior/Canada 25/41 chapter 5500 and so forth. If client selects Sports 26 the chapter identity subset number of one sport Golf 26-A which would include Golf/Barbados 26A/39 chapter 8200, Golf/Bermuda 26A/40 Chapter 8500, Golf/Canada 26A-41 chapter 8800 and so forth.

Secondary organizational hierarchy FIG. 3 continues the composition process with Canadian province subsets. Golf/British Columbia 26A/43, for instance, would be chapter 9700. Therefore, Senior/Canada 25/41 chapter 5500 combined with Golf/Canada 26A/41 chapter 8800 and Golf/British Columbia 26A/43 chapter 9700 would compose an individual sales presentation 49 as represented in FIG. 6 with chapter selections displayed 50.

Integration of LOCAL 21 and REMOTE 30 to compose a sales presentation 52 is a combination of 51 as previously created in 49 and the transitory information 53 from the computerized reservation system 1. Organizational hierarchy, FIG. 2 includes a matrix for necessary information from the remote data sources. For example, Airline Destination Cities 31 could display Canadian cities providing airline service 31/41. Assuming the Senior/Canada/Golf/British Columbia client's presentation integrates Airline Destination Cities/British Columbia 31/43 as shown in FIG. 3 would be displayed. Additional scheduling information 55 such as; Hotel Availability 33A/43 and Airport Transfers 33B/43 would be displayed 54 to complete the sales presentation. It will be understood that multiple data sources can be incorporated in the sales presentation display and calculation of the individual tour expenses can be performed by the microprocessor 14. If the client desires a hard copy of this information it would be available from printer 7, creating an individualized travel brochure for the client.

An important advantage of the highly efficient hierarchical organization of the data bases is the ability of retrieving interrelated information either textual or graphical, by accessing one topic. For instance, the selection of a particular hotel by name would trigger the display of its accommodations along with a touring map of the area fetched from the same local database, as well as data on available airlines services to that area derived from a remote database. Similarly, starting from the graphical display of a touring map, the user may retrieve textual and graphical data about a particular hotel in the area.

This tour creating flexibility, allows the computerized reservation system 1 to market 'special' or discounted tours

12

with short-term availability. Historically, tour operators have been restricted in their ability to promote and market 'special' or discounted tours. The invention solves this dilemma by enhancing computerized reservation system capabilities while presenting timely travel and tour presentations in an individualized sales system.

The travel presentation would continue and if the client desired to reserve or purchase the tour package, the travel agent would process in a traditional manner. Additionally, complex, time-consuming Foreign Individual Tour planning is simplified and made more accurate.

The teaching of this invention allows both the client and travel agent to access travel and tour sales presentations in a highly organized manner. All the necessary functions to create and display individualized sales presentations are performed automatically. This results in significant savings of time for the client and travel agent and will potentially generate additional sales for the travel industry.

It is expected that the automated sales system will be a more convenient means to promote, compose and sell tour packages. Clients should benefit from a more comprehensive presentation of the intangible product of travel. The interactive video and computerized reservation system program design is developed with authoring programs which are well-known to those skilled in the electronic arts.

It will be understood that this automated sales system may be applied to many other types of customer service and sales industries. Some examples are retail sales and real estate and various financial services, as illustrated by the first alternate embodiment of the invention disclosed below.

There is shown in FIG. 7 the general block diagram of an automatic loan processing terminal system. This system may be considered an improvement of the system disclosed in parent application Ser. No. 613,525, now U.S. Pat. No. 4,567,359 whose disclosure is incorporated herein by reference.

The system links a financial institution 101, a plurality of self-service terminals at various remote sites 102 and a credit rating service 103 by telephone lines or other means of telecommunication. The financial institution 101 is provided with a central processor 104 which is used primarily to process loan applications and handle other financial transactions. The central processor 104 has a communication interface which allows it to access the various terminals 105 at the remote sites and be accessed by them at any time of the day. A communication control unit 106 associated with the central processor 104 assures an orderly sending and receiving of information between the terminals and the central processor. The communication control unit 106 provides for a quick transfer of batches of information to and from the terminals 105 under direct access memory mode. Direct access memory modes are achieved by means of high speed data exchange units such as those manufactured by Metacomp, Inc. of San Diego, Calif. and sold under the mark METAPAKS. The central processor 104 is also provided with a terminal monitor and update unit 107 which is programmed for periodically polling the various terminals 105 in order to verify their status and proper operation and to update the data stored in those terminals as may be required. The memory 108 of the central processor 104 holds some files 109 in which are stored textual information about the various loans available to customers from the institution. This information includes loan rates and repayment schedules. These loans include real estate loans, loans to finance the purchase of automobiles, boats and other vehicles, personal loans secured by certificates of deposit,

5,576,951

13

stocks and other assets controlled by the financial institution 101 and unsecured personal loans. Loan packages which have been quoted to customers are stored in a quoted case file 110 pending acceptance and execution by the applicant. Once a loan has been approved and accepted it is processed and monitored through an active case file 111. The credit rating service 103 is an institution such as TRW CREDENTIAL SERVICE which maintains financial files of consumers based on past and current loan payment obligations, credit card uses and balance sheets provided as part of loan applications, and makes that information available to a membership of merchants and financial institutions who need to access the credit worthiness of a particular customer. The credit rating service information is processed automatically by a data processor 112 equipped with automatic communication interface. This interface allows direct access through telephone lines or other communication networks by any subscribing member. The confidentiality of the credit rating service files is guaranteed by use of identifying codes which must be provided with each request.

The system operates as follows. The central processor 104 of the financial institution 101 periodically sends to the terminals 105 at the various sites 102 loan rate information and other data pertinent to the loans available from that institution which are extracted from the loan rate file 109. That textual information is stored in the various terminals and can be reviewed by an applicant in need of a loan. Once the applicant has selected a type of loan which is available from the institution, he is asked to provide the pertinent personal information data which will be necessary to process his loan application. The information provided by the applicant is supplemented by a financial profile obtained directly from the credit rating service after being automatically requested by the terminal 105. The terminal 105 is programmed to compute the credit worthiness of the applicant and to approve or disapprove the loan. Once the loan has been approved the applicant is requested to accept it or reject it. Accepted loan information is transmitted to the central processor of the financial institution and stored in the active case file 111. Information about loans which have not been accepted on the spot, are also transmitted to the financial institution and stored for a period of time in the quoted case file 110. The customer can return to one of the terminals and accept that loan anytime during the validity period.

Turning now to FIG. 8, there is shown a block diagram of the various components of a terminal 105. The operation of the terminal is controlled by a data processor 113. To the left of the processor, various blocks represent the peripheral equipment which interfaces with the applicant. To the right of the processor there is shown a videodisc 114 on which are stored all the permanent data necessary for the operation of the terminal including the data necessary to effect the interactive and automatic request of information by the terminal from the applicant. A modem 115 provides a two-way communication channel with the financial institution 101 and the credit rating service 103. The modem is controlled by the data processor 113 and handles a batch of information through a direct memory access unit 116, to and from a RAM memory 117. Thus, the RAM memory can be used to hold textual data obtained from the loan rate files 109 at the financial institution as well as applicant's financial profiles obtained from the credit rating service 103. The RAM memory can also be used to store some of the operating routines necessary for the operation of the terminal.

Communication with the applicant is done mainly through the video screen 118. The video screen 118 displays

14

the picture of a fictitious loan officer who informs the applicant about the various types of loans available as well as the manner in which the application can be filed. The applicant answers the request of a loan officer by means of a touch pad 119 or a keyboard. Any entry made by the applicant on the touch pad 119 is processed and orally repeated immediately by means of a voice synthesizer 120 and loud speaker 121. The oral expression of the answers provided by the applicant is a way to assure that no false entry is made. A magnetic strip reader 122 may be provided so that the applicant can give an account number or an identification by means of a credit card. A printer 123 is used to deliver to the applicant a hard copy of any loan quotation as well as a confirmation of his accepted loan.

FIG. 9 is a flow diagram of the system operation during the initial phase of the loan application process. The start 124 of system operation is triggered either by the applicant pushing a start button or by the automatic detection of his presence in front of the terminal. Once the system is activated 125 the recording of an image and sound of a fictitious loan officer is read from the videodisc 114 and graphically appears on the video screen 118. The fictitious loan officer takes the applicant through a language selection routine 126-129. In this case the applicant is asked in both English and Spanish in what language the loan transaction is to be conducted. In this phase of the operation as well as all interactive communications between the loan officer and the applicant, the loan officer explains to the applicant how to enter his answer by means of the touch pad 119. The applicant is then asked whether a previous quotation has already been prepared for him 130. In the affirmative, he is then requested 131 to enter a pass number or identification number either by entering the number on the touch pad or by running his credit I.D. card through the strip reader 122. The terminal then addresses the financial institution and requests 132 the prior loan quotation stored in the quoted case file 110 of the central processor 104. This is done by the data processor 113 of the terminal dialing the institution phone number through the modem 115 and sending a request message. The terminal goes into a standby mode with its DMA unit 116 waiting for a transfer of information from the line into the RAM memory 117. The continued operation depends on whether or not the previous quotation is found 134 to be on file. If the answer is negative, the fictitious loan officer instructs 135 the applicant how to proceed to apply for a loan. In the case where a previous quotation is found to be on file, that quotation is transferred to the terminal according to the program routine B illustrated in FIG. 11.

FIG. 10 is the flow diagram of the system operation during the acquisition of information by the terminal from the applicant. The applicant is first asked to select 136 the type of loan in which he is interested. In this case, he is offered a menu allowing him to choose between a real estate loan 138, a vehicle loan 139, a personal loan 140 secured by an asset held by the financial institution or a personal unsecured loan 141. Any invalid selection 137 triggers a new request. Once a type of loan has been selected, a real estate loan, for example, the fictitious loan officer asks a series of inquiries corresponding to the questions that would be found on a standard loan application form. For each question the system performs a subroutine 142-145 designed to guarantee proper input of the information into the terminal memory 117. If a problem develops during the question and answer period, the applicant is invited to call 144 the loan service at the financial institution. If the answer to a question is not received within fifteen seconds 145, the process of application is presumed to have been abandoned by the applicant

5,576,951

15

and the system returns to its initial standby state. Once all the proper answers have been accepted they are processed 146 by the terminal data processor 113. This process may involve analyzing certain key answers in order to identify any element or data that would automatically disqualify the applicant. Depending upon the result of that first analysis, more questions 147 may be presented to the applicant in order to refine the data necessary for a thorough assessment of his qualifications, or to provide additional information for the applicant.

For instance, the fictitious loan officer may ask, "Are you familiar with our loan repayment schedule?" If the customer desires to read the loan repayment schedule, he would indicate his choice. The loan schedule would then be textually displayed. After reading the text, the applicant would proceed to more questions 147 presented by the fictitious loan officer. The customer could continue to additional textual displays about legal responsibilities of obtaining a loan or return to the fictitious loan officer who would continue the presentation.

Turning now to FIG. 11, the B subroutine used to receive a previous quotation from the financial institution is illustrated in the first flow diagram. Once the previous quotation is requested 148 the DMA unit 116 of the terminal is allowed to receive a batch of information containing the previous quotation. This batch of information is stored in the RAM memory 117 from where it is fetched 150 and displayed 151 on the video screen 118. The applicant is then asked if he wants a hard copy 152 of the quotation. In the affirmative, the previous quotation is printed 153 on printer 123. The second flow diagram corresponds to the acquisition of the applicant's financial profile from the credit rating service 103. Once a loan quotation has been presented to the applicant he is asked whether or not he wants to apply for the loan 154. If his answer is negative, the fictitious loan officer expresses final greetings 155. The loan quotation, if not already in storage at the financial institution, is transmitted there for temporary storage in the quoted case file 110 of the central processor 104. If the applicant wishes to apply for the loan, he is asked to provide a password or identification 156 which will allow the terminal to access his file at the credit rating service 103. As previously explained, this number can be entered directly by means of an identification card run through the strip reader 122 or entered manually 157 by means of the touch pad 119. The terminal requests a rating 158 from the credit rating service 103 in a manner similar to the one used and described previously for obtaining a previous quotation from the financial institution. The applicant's financial profile is received as a batch of information through the DMA unit 159 and then read from the memory 160. The financial profile is then analyzed by the terminal in order to compute 161 a debt ratio or other criterion devised by the financial institution to access the credit worthiness of the applicant. The debt ratio is the ratio of the applicant's current expenses to his current income. Other parameters such as debt to equity ratio or fixed assets to debt may be computed by the terminal data processor 113 and used in determining the qualifications of the applicant. It should be noted that the entire decision whether or not to grant the loan is performed automatically and onsite by the terminal 105 without intervention whatsoever from any of the financial institution personnel, except in case of breakdown in communications requesting a direct phone call by the applicant to the financial institution.

The last flow diagram on the drawing represents the final phase of the loan application transaction. Once the terminal equipment has determined that the applicant qualifies 162

16

for the loan, the applicant is so notified 163, and instructed how to obtain the loan funds. The institution is also notified 165, and the loan is processed through the active case file 111 by the central processor 104. The fictitious loan officer closes the transaction by giving his final greetings 166 before the system is returned to a standby condition. If the applicant does not qualify for the amount of loan requested, he is first asked whether a lesser amount 167 would be acceptable to him. He is then instructed to enter the lesser amount 168 through the touch pad 119. That new amount is then checked against the determination already made by the terminal. The process is repeated until an acceptable amount is requested by the applicant, or until such time as the applicant declines to proceed with the loan application.

It should be noted that the system as described could be applied to other forms of transactions in which information has to be acquired from a customer then processed to a decision or into the performance of a particular task. A similar system could be used, for instance, for the preparation and filling-out of income tax returns. In such case, the assistance that the fictitious person who appears on the video screen can give to the applicant in filing the tax form can be easily programmed on the videodisc.

A system adapted to the sale of real estate properties would use interrelated textual and graphical information stored on the videodisc 114. The inquiries 142 displayed on the video screen 118 would consist of real estate information designed to both inform and address applicants needs. To facilitate customer interaction, the graphical display could include city maps designated by zip code areas so the applicant could indicate the location of his or her current residence. Other interrelated displays would present types of dwellings, i.e., single, family or commercial, of pictorial representations which aid the applicant in determining his or her loan needs.

Other applications of the system include the selection and purchase of stocks and other securities, the selection and opening of so-called 'self-directed investments' such as Individual Retirement Accounts, and other complex transactions which normally require a great deal of time and attention on the part of the officers of an institution.

FIG. 12, a second alternate embodiment, shows an overview of an automatic system for dispensing information, goods and services from multiple retail, travel, financial, grocery and other service industries.

The system basically comprises a data processing center 201 linked to various remote sites, including one or more information and sales stations 202, a credit reporting service terminal 203, and data processing terminals 204 of various goods and services providers. The station and terminals are all linked to the central data processing center by any suitable remote links such as phone line data and cable television communications 209. The provider's terminals 204 are indirectly linked to the data processing center 201 via a computerized telecommunication network service such as TELENET® 205. Each of the providers and the system has its own specific account number with the service, which can be accessed by either party to submit or retrieve information at periodic intervals.

In this embodiment of the invention, numerous sales and information stations 202 are provided at a series of locations such as homes or offices. The terminals are all remotely linked to the data processing center. The information and sales terminals 202, typically comprise a CRT monitor, audio-speaker device and controller located in the customer's residence or office. The CRT monitor receives selected

5,576,951

17

prerecorded audio-visual segments via the cable television company's communication links 209, generated at the data processing center 201. As illustrated in FIG. 17, this equipment may consist of a common television receiver 274 and a dial tone telephone, also located in the customer's residence or office, that functions as the entry device allowing selection of various audio-visual presentations to be displayed on the television screen.

Once a voice communication has been established between the telephone handset 275 and the data processing center, the tone generating keypad 276 is used to generate and send to the processor by way of the telephone network 280, coded instructions representing a request for information to be displayed on the television receivers 274. After viewing the requested information on his television set, the customer can use the telephone keypad 276 to order goods or services selected among those displayed on the television receiver. The customer also can transmit a credit account number against which the purchase can be charged. Voiced requests, orders or payment authorization could also be transmitted by means of the telephone handset 277 to be automatically recognized and interpreted by an automatic speech recognition device at the data processing center. Since the data processing center transmits a great deal of information to be accessed by a large number of stations through a common cable television network 281, the television receivers 274 must be coupled to an information selector unit 279 which looks for information which has been specifically addressed to that particular station and routes it to the television receiver 274. The address code which is used as a key by the information selector 279 to select data on the cable television network 281 may be a fixed number permanently entered into the information selector, or a variable number which is generated from the keypad 276 as part of the requests for goods or services and temporarily stored in a key code register 278 to be fed to the information selector 279. The same key code is also stored at the data processing center as it is transmitted on the telephone network 280 and is used to frame the specific information which is transmitted over the cable television network 281. Preaddressed information may also be periodically transmitted over the cable television network 281. The address or access number to available products or services may be published in printed catalogs for use from the various stations to request specific displays of information. The information selector 279 and key code register 278 may be part of the cable television signal descrambling device 282 such as those commonly used with pay cable television services. This type of communication system is based on the well-known technology such as was disclosed in U.S. Pat. No. 3,746,780 Stetten et al. and other patents cited in the background of this specification.

The data processing center 201, basically comprises a tone or voice response system, host computer and data sources. The tone or voice response system 221 receives the customer's selections in audio signal form and converts the signals to messages which are transmitted to the central processor 222 for selection of data sources. Additionally, the tone or voice response system allows customers the ability to enter requests on their keypads and receive audio information in the form of synthesized human speech which is transmitted via the standard telephone communication links. Features of voice response systems include; interfaces with all major host computers, high quality digitally encoded voice, extended storage capacity of synthesized speech, support for multiple software applications and the ability to handle dozens of simultaneously incoming calls. A suitable

18

voice response system is the VCT Series 2000®, manufactured by Voice Computer Technologies Corporation, although many alternatives are available.

The host computer can be one of those manufactured by IBM, NCR or Digital Equipment Corporation, which has the ability to direct the incoming requests, store and manage the data sources and generally perform data processing functions.

The data sources typically consist of prerecorded audio-visual segments stored on optical discs and transitory alphanumeric price and stock information stored in the host computer's memory. Although several data storage technologies can perform the audio-visual product presentation including digitized information, the preferred choice is optical disc storage. Optical disc storage technology is commonly referred to as videodisc and CD-ROM. Suitable optical storage discs are Scotch® Laser Videodiscs manufactured by 3M Corporation. Industrial videodisc players which are designed for allowing sequential or random access of 54,000 individual video frames or the playback of 30 minutes of full-motion on a single disc, include model LD-6200 manufactured by Pioneer Communications of America, Inc. The LD-6200 has the extensive capabilities of the IEEE-488 parallel interface port which is particularly well suited for multiple player control with a single external computer. Multiple laserdisc players controlled from a single external computer offer a flexible configuration allowing simultaneous access from numerous users with system expansion a factor of customer demand. To increase the enhancement of still-frame video presentation, audio compression technology is utilized. Still-frame decoder technology which allows 30 seconds of audio compression in an individual video frame is the subject of U.S. Pat. No. 4,429,332, Television Compressed Audio. This technology increases the optical disc data sources communicative capacity with audio compression and is available in model VAC-300 manufactured by EECO, Inc.

Although several alternative transmission technologies exist, it is assumed that cable television operating companies can provide one of the most reliable, high quality audio-visual transmission networks. Cable television transmission of selected audio-visual segments can be achieved by multiple means including addressable video signal encryption configured at the cable head end and downloaded to a decoder at the home terminal for program descrambling.

The customer activates the audio-visual presentations by dialing the keypad 276 requesting access to the system through the telephone network 280 to the data processing center 201. A voice response system 221 at the data processing center accepts the customer's inquiries and audibly answers questions from its voice synthesis storage. Customer requests for audio-visual presentations are relayed from the voice response system to the central processor 222, which selects the appropriate data sources for transmission to the local cable television company 210 and routed via the cable network 281 to the customer's terminal 202. The customer upon viewing the presentation, which includes a menu, selects from the displayed menu on the video screen his next selection which is then entered on the keypad and is transmitted to the central data processing center for assembly of the requested informational segment to be routed to the sales and information terminal. This circuitous sequence continues until the customer, decides to abort access, is terminated due to preset time allotments or purchases a product or service. If he decides to order a service or product he would then enter his purchase and payment by either an account identification or credit card number on the

5,576,951

19

telephone keypad 276, which would be authorized upon verification of the customer's credit worthiness by a credit information service or the central data processing center. Upon acceptance of the customer's order, the central data processing center would transmit to the customer's station a confirmation number and order fulfillment information which is displayed on the video screen. Customer orders for goods or services are then transmitted to the provider 204 for order fulfillment.

The interfacing of the various components of the system described above is done according to standard practices well known to those skilled in the electronic arts.

The data processing center 201, includes a central processing unit 222 and memory 223. The memory 223 stores graphical program information, management of the audio-visual sources and textual information on prices of products and services acquired from the providers, which are periodically updated from the terminals 204 of the various companies, and information on customer requests and orders which can be accessed periodically by the respective providers. The processing unit 222 operates in response to program instructions for performance of product and service calculations in response to customer information and orders received from any of the stations, to send audio-visual product and service data to the respective stations, to receive credit account numbers from the stations and access the credit reporting terminal for credit approval or disapproval of a particular account. If a customer places a purchase order from a station after credit is approved, the data processing unit stores the information and sends a confirmation to the terminal.

The various programs for executing the operations of the sales and information terminal and the data processing center computer 222 are of a 'menu-type' and can best be understood with reference to the flow diagrams of FIGS. 13 through 16. FIGS. 13 and 14 show the sequence of operations executed at the sales and information terminal 202 and FIGS. 15 and 16 show the operations performed by the data processing center's computer 222 for the on-line and off-line processing and communications with the providers.

The sequence of operations basically comprises the following steps:

(1) The customer activates the system by entering a sequence of numbers, on the keypad device, which are transmitted to the data processing center;

(2) A voice response system at the data processing center acknowledges customer's inquiry, verifies his authenticity and interrogates the customer to determine the desired services;

(3) The voice response system transmits the customer's requests to the central processor;

(4) The central processor selects the appropriate data storage sources and transmits the audio-visual information to the customer's local cable television company communication links;

(5) Requested information and menus are relayed through the cable channel and displayed on the CRT video screen;

(6) If the customer wishes to purchase a product or service he proceeds with the payment protocol as displayed on the CRT and enters the form of payment, on the keypad, which is then transmitted to the data processing center;

(7) Upon authorization of payment, a confirmation message is transmitted from the data processing center to the sales and information station's video display monitor;

(8) Upon completion of customer access the system disconnects;

20

(9) The data processing center stores the information on products or services sold;

(10) At the end of every day, the data processing center transmits information on the daily sales activities for each provider to the appropriate files of the Telenet® computer;

(11) The sales information for each provider can be accessed from its terminal linked to the Telenet® computer. At the same time, the service providers can transmit updates on prices and products to their system account at the Telenet® computer.

These steps will now be described in more detail with reference to FIGS. 13 to 16.

Referring now to FIG. 13, each sales and information terminal will be in an inactive state with system activation initiated by the customer entering a number on the keypad 276 and requesting access to services 224 from the data processing center 201. If access is available through an open line, the customer logs on 225 and begins a synthesized speech dialogue with a voice response system 226. For example, the voice response system may ask, "Are you interested in connecting to our shopping service?", "If yes, please press key #3" or "Do you have a question about a previous order?", "If yes, please press key #4." The audio interaction verifies the customer's identification 227 and determines their geographic location for routing of requested presentations. The dialogue also determines if emergency access 232 to the system is required. The customer responds to the questions by entering his answers on the keypad 276. If a customer is unable to dialogue with the voice response system, he may enter a specific key for communication with a human operator 228. The human operator would assist the customer with questions, emergency access or selections of program material. If the human operator is unable to provide assistance, he thanks the customer 229 and the communication would cease 230.

If data sources are available for access 231, the voice response system begins a transmission of signals to the central processor 222, for selection of data sources. If the customer has an emergency 232 the voice response system activates a priority mode to the central processor and begins an immediate routing of presentation of an emergency menu display 233, on the customer's video display screen.

An important aspect of the present invention is its ability to transmit emergency life-saving instructions to consumers. For example, a mother whose young child has just ingested poison or received a serious cut could access the system, state that an emergency has occurred and the system would interrupt any current user on conflicting transmission links and begin presentation of emergency first-aid medical information. Simultaneously the system would alert medical authorities or personnel as to the injury. In many instances, audio-visual medical emergency procedures can serve critical needs during the first few minutes of injury, drowning or heart attack. Consumers would have instantaneous access to a comprehensive first-aid 'assistant' in the form of audio-visual presentations specifically addressing medical needs in their home or office.

The menu display 233 presents a series of selections in which choices are available to navigate through the numerous decision-making branches of possible interactions. The main menu 233 presents the general categories of products and services which are available such as: retail, travel, financial and grocery. The interactive sequence of customer-selected information displayed on the television receiver is continuous and a typical audio-visual presentation would include choices accompanied with numbers which corre-

5,576,951

21

spond to the keypad 276 of the telephone or similar control device. For example, key #5 would be—repeat, key #6 would be—return to main menu, key #7 would be—new selection and so forth. The customer would then be able to enter on his controller device the next desired sequence of information. The customer can quickly locate a specific product or service by defining his selections through the menu. For example, if the customer is interested in lamps he would begin with a retail display menu 234. The customer would then select from the second frame, home furnishings 235 and from the third frame of home furnishings the customer would select lamps 236. Therefore, within three consecutive interactions the customer commences evaluation of various lamp features. The current price of the lamp and other transitory information is stored in the data sources 223 and by use of an overlay, this timely textual information is superimposed and displayed simultaneously, with the prerecorded audio-visual presentations. Therefore at all times current price and product availability are maintained by the central data processing center 201 and presented to the customer.

If the customer encounters any problems in operating the system he or she can enter a specific command on the control device to communicate with a human operator for assistance.

Referring now to FIG. 14, during the selected presentations the menu also displays a numbered key for entry on the control device for an order of a product or service 240. Product ordering menu questions would include; quantity, color, sizes and styles. If the customer decides he doesn't wish to continue or order products or services he is offered a final greeting 241, and the system access is disconnected 251. Once the customer has completed his selection 243 the data processing center tabulates the orders and other relevant information and transmits the desired purchase summary to the sales and information terminal 244. The menu asks the customer 245 if the ordered items are correct? Assuming the customer proceeds with the purchase, he would examine the listed items textually displayed on the monitor's screen and either accept or correct the list. If incorrect, the customer would continue the interactive menu sequence or contact the human operator for assistance 228. When the customer has completed his selections he would proceed to the payment process menu 246. This menu explains the various forms of payment, typically the customer has an established account number on file 247. The customer would enter a PIN (Personal Identification Number), credit card number 248 or other suitable payment data manually on the keypad. Once the payment data has been obtained by the central data processing center a payment verification procedure is initiated, as will be described in more detail below in connection with FIG. 15. The procedure results in either rejection or acceptance of payment and corresponding data is transmitted from the data processing center to the terminal and displayed on the television screen.

If payment is rejected, the customer can either insert additional payment information 248 on the keypad or call the customer service for assistance 228.

If payment is accepted, 249 the customer receives a confirmation number that is displayed on the television and is asked to enter any additional delivery information, such as a person or address that is to receive the product or service ordered or a specific time of the day for delivery. The customer is then thanked, the dial-up line to the data processing center 201 is disconnected, and the terminal communication to the data processing center returns to an inactive state 224.

22

The sequence of operations conducted by the data processing center 201 performing product and service selections, executing credit checks and issuing sales confirmations will now be described with reference to the flow diagram parts, shown in FIG. 15.

When the data processing center receives a product or service request B from one of the sales and information stations 202, it first determines the type of product or service required 252. The central processor 222 then locates the appropriate graphical and/or textual information for that product from its transitory and audio-visual data sources for assembly and transmission to the selected communications company 254 and subsequently to the terminal 255.

Upon receipt of payment verification request C from a terminal 256, the data processing center locates the customer's account file 257 from its memory or transmits the account number to the credit information terminal 258. The results of the verification process 259 are received by the processing center and relayed to the terminal. If payment is rejected, the customer is notified at the terminal 260. If payment is accepted, a product or service information record 261 is created at the data processing center and the customer is notified at the sales and information terminal 262.

After the data processing center has processed D the product payment 263, it issues a confirmation at the terminal and the product or service information file is updated with the name and address of the customer 264. The product or service confirmation is transmitted to the terminal for acceptance by the customer 265.

The data processing center 201 performs a number of programmed off-line operations at periodic intervals, as illustrated by the flow diagram in FIG. 16. The product and service information files stored in the memory are updated daily.

The data processing center routinely performs a series of daily activity status reports E. The daily reports include a sales activity report 263 listing all sales and service transactions for the particular day's processing, payment verification reports 264 listing all payments verified by company number sequence, and audit trail reports 265 listing all sales for a particular company or geographic regions, customer profiles and other marketing information.

A sales data file 266 is created for all sales transacted for each company in that particular day's processing. This file is forwarded to the appropriate service provider's computer terminal 204 via Telenet® to be entered in their automated billing system. The data processing center dials a central computer such as the Telenet® computer 205 to which all the service provider company's terminals are linked, logs-on to the appropriate account for each company, and transmits the appropriate daily reports and sales data files to each company's specific Telenet® account. The product or service provider can then retrieve the information in its account at its pleasure by dialing the Telenet® computer from its own computer terminal 204, to process and complete order fulfillment.

The data processing center also performs monthly processing programs F, these routines 267 consist of valuable sales data compilation which includes a payment verification report listing all payments verified for a given company during that month 268 and a sales activity report listing all sales processed for a specific company for a particular month 269. These reports are transmitted to the relevant account numbers of the Telenet® computer for subsequent retrieval by the respective companies and the daily reports.

Data requests G can also be made by the individual service providers via their terminals 204 and the Telenet®

5,576,951

23

computer 270. When a service provider wants a certain program to be performed, a memo is sent from the company's terminal to the specific Telenet® account number for the data processing center, stating which report is to be processed. The reports G which can be requested in this way are the sales analysis reports 271 and reports for each type of product or service for a specific company. The sales reports allow each company to update its price rates and product availability in the system as necessary. The sales analysis reports can provide listings by company, product type, date, and time of day. Therefore service providers can obtain valuable market research and analyze their advertising and sales promotion for specific products.

Programs H are provided for maintaining current product and service prices stored by the data processing center. The prices are updated by checking the rate files for each company's product line offered 272. Utility programs are maintained for all product and service providers 273.

The system of this invention allows a customer convenient access to numerous products and service providers in a variety of industries and allows the customer to make a selection and purchase products on a self-service or operator-assisted basis. All the necessary operations of obtaining information, checking credit and transmitting information to the respective companies are performed automatically. Significant savings in time and money will be realized for both the consumer and companies that will potentially result in more sales and increases in productivity because thousands of consumers will have greater accessibility to the service providers in their homes.

The general public will benefit from direct marketing communication channels with manufacturers and monetary savings will be realized as traditional retail product sales overhead is reduced.

It will be clear that this system may be applied to many other types of customer service and sales industries. Some examples are the educational industry, many types of governmental services, and the medical and health industries.

While the preferred embodiments of the invention have been described, modifications can be made and other embodiments may be devised without departing from the spirit of the invention and the scope of the appended claims.

What is claimed is:

1. A computer search system for retrieving information, comprising:
 - means for storing interrelated textual information and graphical information;
 - means for interrelating said textual and graphical information;
 - a plurality of entry path means for searching said stored interrelated textual and graphical information, said entry path means comprising:
 - textual search entry path means for searching said textual information and for retrieving interrelated graphical information to said searched text;
 - graphics entry path means for searching said graphical information and for retrieving interrelated textual information to said searched graphical information;
 - selecting means for providing a menu of said plurality of entry path means for selection;
 - automatic data processing means for executing inquiries provided by a user in order to search said textual and

24

graphical information through said selected entry path means and for fetching data as a function of other data; indicating means for indicating a pathway that accesses information related in one of said entry path means to information accessible in another one of said entry path means;

accessing means for providing access to said related information in said another entry path means; and

output means for receiving search results from said processing means and said related information from said accessing means and for providing said search results and received information to such user.

2. The search system according to claim 1, wherein said textual information comprise words, phrases, numbers and letters stored in said at least one database.

3. The search system according to claim 1, wherein said graphical information include maps, charts, pictures, and moving images.

4. The search system according to claim 1, wherein one of said graphical and textual information comprises audio information.

5. The search system according to claim 1, wherein said graphical and textual information are stored on a CD-ROM disc.

6. The search system according to claim 1, further comprising a micro-computer for executing operations of said search system, and for storing said graphical and textual information.

7. The search system according to claim 1, wherein said textual entry path means and said graphical entry path means include informing means for assisting a user in searching said graphical and textual information.

8. The search system according to claim 1, wherein said textual search entry path means comprises a topic tree entry path means for dividing said textual information into topics and sub-topics in order to assist in browsing through said textual information.

9. The search system according to claim 1 which further comprises:

title finder entry path means for assisting a user in uncovering titles stored in said stored textual information.

10. A computerized system for selecting and ordering a variety of information, goods and services, which comprises:

a plurality of computerized data processing installations programmed for processing orders for said information, goods and services;

at least one computerized station, said station including:

a micro-processor;

a device for displaying graphical and textual material;

at least one mass memory device controlled by said micro-processor;

means for addressing at least one of said computerized data processing installations, and for sending thereto and receiving therefrom, coded messages and batches of data;

program means for controlling the display on said display device of inquiries and acceptable answers;

user operated means for selecting at least one of said acceptable answers;

means for accumulating a set of said acceptable answers; automatic data processing means for processing said set of answers as a function of other data;

means for storing in said mass-storing device, interrelated textual information and graphical information;

5,576,951

25

means for interrelating said textual and graphical information;
a plurality of entry path means for searching said stored interrelated textual and graphical information;
means, responsive to said means for processing, for executing inquiries provided by said user and for searching said textual and graphical information through said selected entry path means;

26

said means for executing and searching, including means for addressing at least one of said installations and for retrieving data related to said answer; and
means responsive to said means for processing, for transferring orders for said information, goods and services to said installations.

* * * * *

UNITED STATES PATENT AND TRADEMARK OFFICE
CERTIFICATE OF CORRECTION

PATENT NO. : 5,576,951

DATED : NOVEMBER 19, 1996

INVENTOR(S) : LAWRENCE B. LOCKWOOD

It is certified that error appears in the above-identified patent and that said Letters Patent is hereby corrected as shown below:

Claim 9, Column 24, line 38, change "1" to --1,--.

Claim 10, Column 26, line 6, change "installations" to --installation--.



Signed and Sealed this
Ninth Day of June, 1998

Attest:

A handwritten signature in cursive script, appearing to read "Mary H. Queen".

Attesting Officer

A handwritten signature in cursive script, appearing to read "Bruce Lehman".

BRUCE LEHMAN

Commissioner of Patents and Trademarks

UNITED STATES PATENT AND TRADEMARK OFFICE
CERTIFICATE OF CORRECTION

PATENT NO. : 5,576,951
DATED : November 19, 1996
INVENTOR(S) : Lawrence B. Lockwood

Page 1 of 4

It is certified that error appears in the above-identified patent and that said Letters Patent is hereby corrected as shown below:

- In Column 1, line 38, replace "processing," with --processing--.
- In Column 1, line 57, replace "reserve-and" with --reserve and--.
- In Column 2, line 47, replace "person," with --person--.
- In Column 2, line 63, replace "by" with --by the--.
- In Column 4, line 28, replace "and shop" with --to shop--.
- In Column 4, line 32, replace "The system" with --This system--.
- In Column 5, line 13, replace "communication's" with --communication--.
- In Column 6, line 60, replace "passive" with --his passive--.
- In Column 7, line 44, replace "their" with --his--.
- In Column 7, line 51, replace "up-dated" with --updated--.
- In Column 9, line 54, delete the reference character "A1".
- In Column 17, line 6, replace "office," with --office--.
- In Column 18, line 63, replace "customer;" with --customer--.
- In Column 19, line 44, replace "numbers," with --numbers--.
- In Column 21, line 45, replace "payment, typically" with --payment. Typically,--.
- In Column 22, line 24, replace "D" with --D,--.

UNITED STATES PATENT AND TRADEMARK OFFICE
CERTIFICATE OF CORRECTION

Page 2 of 4

PATENT NO. : 5,576,951
DATED : November 19, 1996
INVENTOR(S) : Lawrence B. Lockwood

It is certified that error appears in the above-identified patent and that said Letters Patent is hereby corrected as shown below:

In Column 23, line 52, replace "textual" with --textual information--.

In Column 23, line 55, replace "textual" with --textual information--.

In Column 23, line 59, replace "text" with --textual information--.

In Column 23, line 56, replace "graphics" with --graphical--.

In Column 23, line 67, replace "textual" with --textual information--.

In Column 24, line 14, replace "numbers" with -- numbers,--.

In Column 24, line 20, replace "graphical" with --graphical information--.

In Column 24, line 23, replace "graphical" with --graphical information--.

In Column 24, line 27, replace "graphical" with --graphical information--.

In Column 24, line 30, add --search-- between "textual" and "entry".

In Column 24, line 32, replace "graphical" with --graphical information--.

In Column 24, line 44, replace "goods" with --goods,--.

UNITED STATES PATENT AND TRADEMARK OFFICE
CERTIFICATE OF CORRECTION

PATENT NO. : 5,576,951
DATED : November 19, 1996
INVENTOR(S) : Lawrence B. Lockwood

Page 3 of 4

It is certified that error appears in the above-identified patent and that said Letters Patent is hereby corrected as shown below:

In Column 24, line 48, replace "goods" with --goods,--.

In Column 24, line 51, replace "graphical" with --graphical information--.

In Column 24, line 51, replace "material" with --information--.

In Column 24, line 65, replace "mass-storing" with --mass memory--.

In Column 25, line 1, replace "textual" with --textual information--.

In Column 25, line 4, replace "textual" with --textual information--.

In Column 25, line 7, replace "textual" with --textual information--.

In Column 26, line 5, replace "goods" with --goods,--

UNITED STATES PATENT AND TRADEMARK OFFICE
CERTIFICATE OF CORRECTION

PATENT NO. : 5,576,951
DATED : November 19, 1996
INVENTOR(S) : Lawrence B. Lockwood

Page 4 of 4

It is certified that error appears in the above-identified patent and that said Letters Patent is hereby corrected as shown below:

In Figure 9, numbers 128 and 129, replace "Presentate" with
--Presentation--.



Signed and Sealed this
Tenth Day of February, 1998

Attest:
Mary H. Queen
Attesting Officer

Bruce Lehman

BRUCE LEHMAN
Commissioner of Patents and Trademarks

(12) **United States Patent**
Lockwood

(10) **Patent No.:** US 6,289,319 B1
 (45) **Date of Patent:** Sep. 11, 2001

(54) **AUTOMATIC BUSINESS AND FINANCIAL TRANSACTION PROCESSING SYSTEM**

(76) **Inventor:** Lawrence B. Lockwood, 5935 Folsom Dr., La Jolla, CA (US) 92037

(*) **Notice:** Subject to any disclaimer, the term of this patent is extended or adjusted under 35 U.S.C. 154(b) by 0 days.

(21) **Appl. No.:** 08/347,270

(22) **Filed:** Nov. 30, 1994

Related U.S. Application Data

(63) Continuation of application No. 08/096,610, filed on Jul. 23, 1993, now abandoned, and a continuation of application No. 07/752,026, filed on Aug. 29, 1991, now abandoned, and a continuation of application No. 07/168,856, filed on Mar. 16, 1988, now abandoned, and a continuation of application No. 06/822,115, filed on Jan. 24, 1986, now abandoned, which is a continuation-in-part of application No. 06/613,525, filed on May 24, 1984, now Pat. No. 4,567,359.

(51) **Int. Cl.** ⁷ G06F 17/60

(52) **U.S. Cl.** 705/35

(58) **Field of Search** 364/408, 406; 235/381, 380, 379; 705/35, 38, 4

(56) **References Cited**

U.S. PATENT DOCUMENTS

4,333,152 * 6/1982 Best 395/152
 4,359,631 * 11/1982 Lockwood et al. 235/381
 4,553,206 * 11/1985 Smutek et al. 395/275
 5,146,404 * 9/1992 Calloway et al. 364/401

OTHER PUBLICATIONS

Young, G, "Computer firm to help buyer, shop for loan", Washington Post, Virginia, Real Estate Section, Apr. 9, 1984 (Nexis™ Excerpts).*

* cited by examiner

Primary Examiner—Robert Beausoleil

Assistant Examiner—X. Chung-Trans

(74) *Attorney, Agent, or Firm*—Henri J. A. Charmasson; John D. Buchaca

(57) **ABSTRACT**

A system for filing applications with an institution from a plurality of remote sites, and for automatically processing said applications in response to each applicant's credit rating obtained from a credit reporting service comprising a series of self-service terminals remotely linked via a telephone line to a first computer at the institution and to a second computer at the credit reporting service headquarters. Each remote terminal comprises a video screen and a video memory which holds image-and-sound-generating information arranged to simulate the aspect and speech of an application loan officer on the video screen. The simulated loan officer is used to acquire loan request data from the applicant by guiding him through an interactive sequence of inquiries and answers. The terminal is programmed to acquire credit rating data relating to the applicant from the credit rating service, and to use the data to compute the credit worthiness of the applicant and the amount which may be loaned to him. The approved loan information is then transmitted to the first computer for further processing by the financial institution.

6 Claims, 5 Drawing Sheets

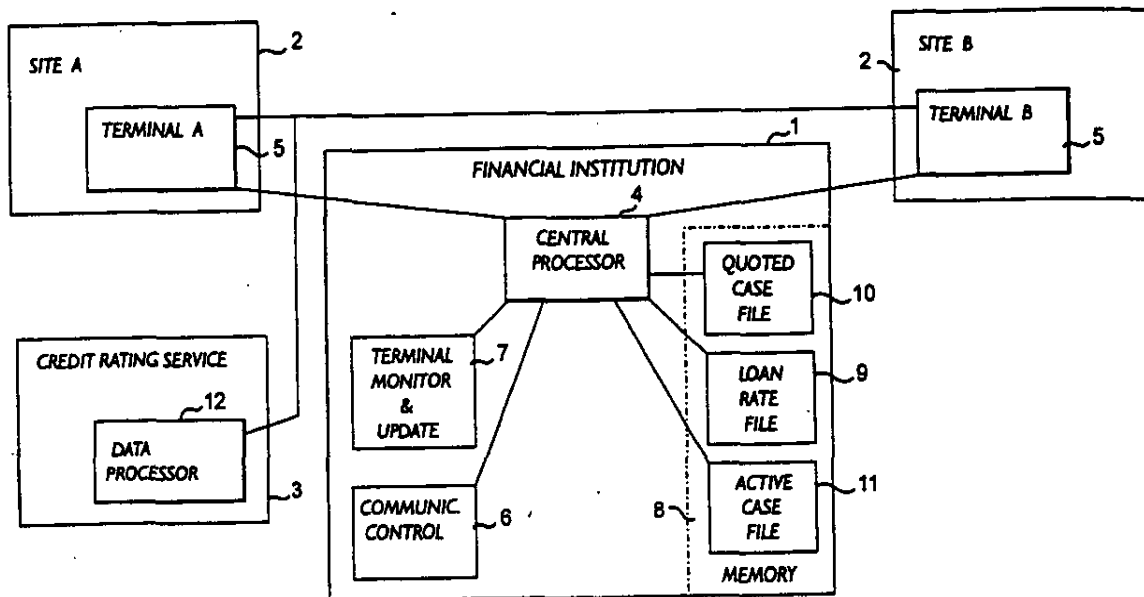

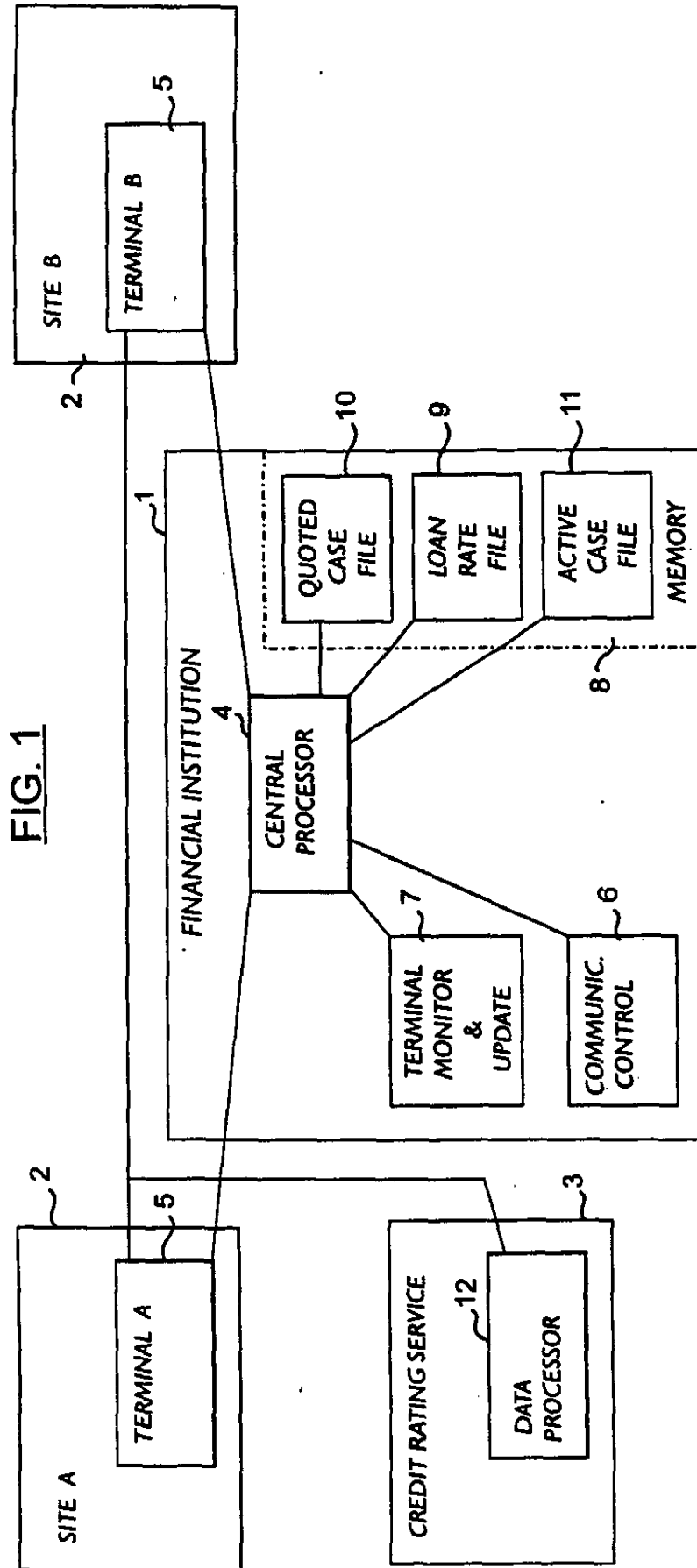

FIG. 1

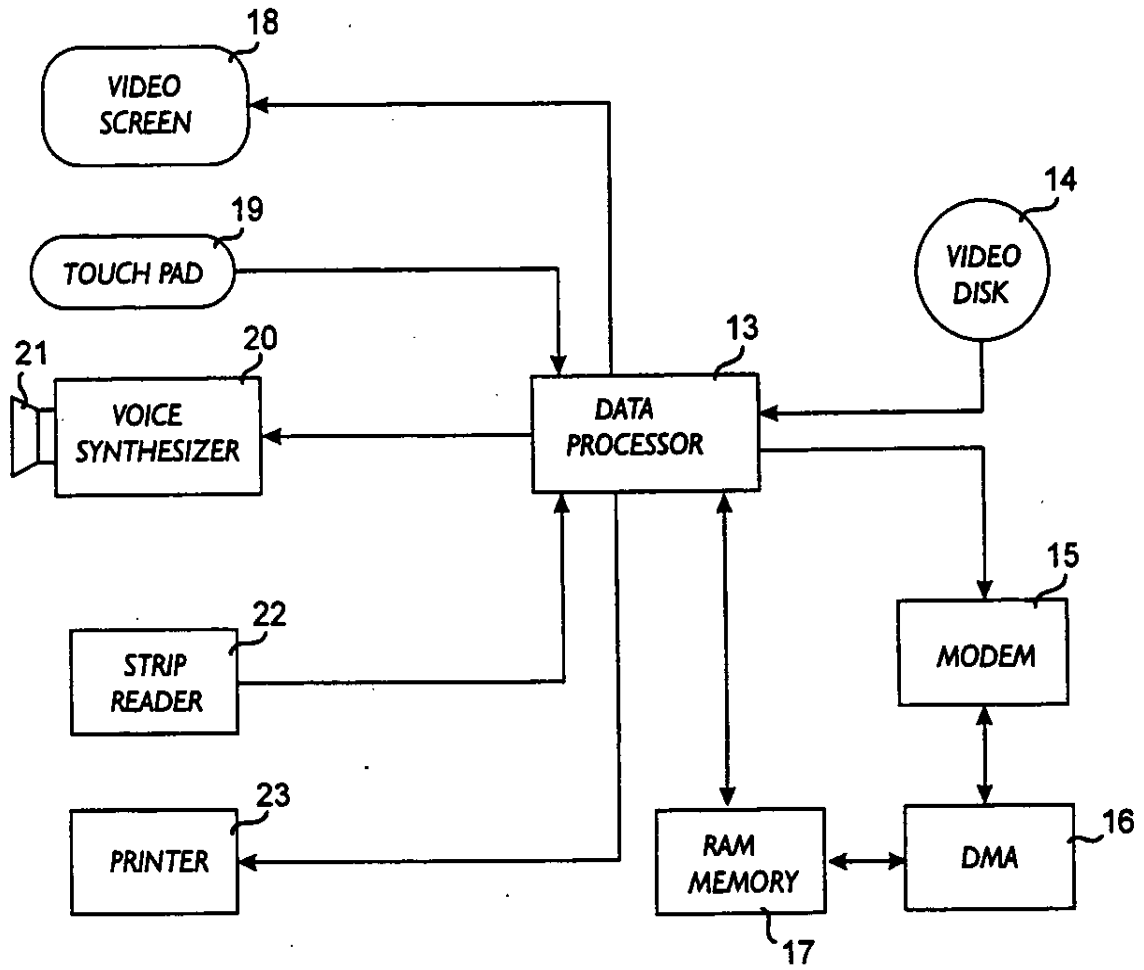

FIG. 2

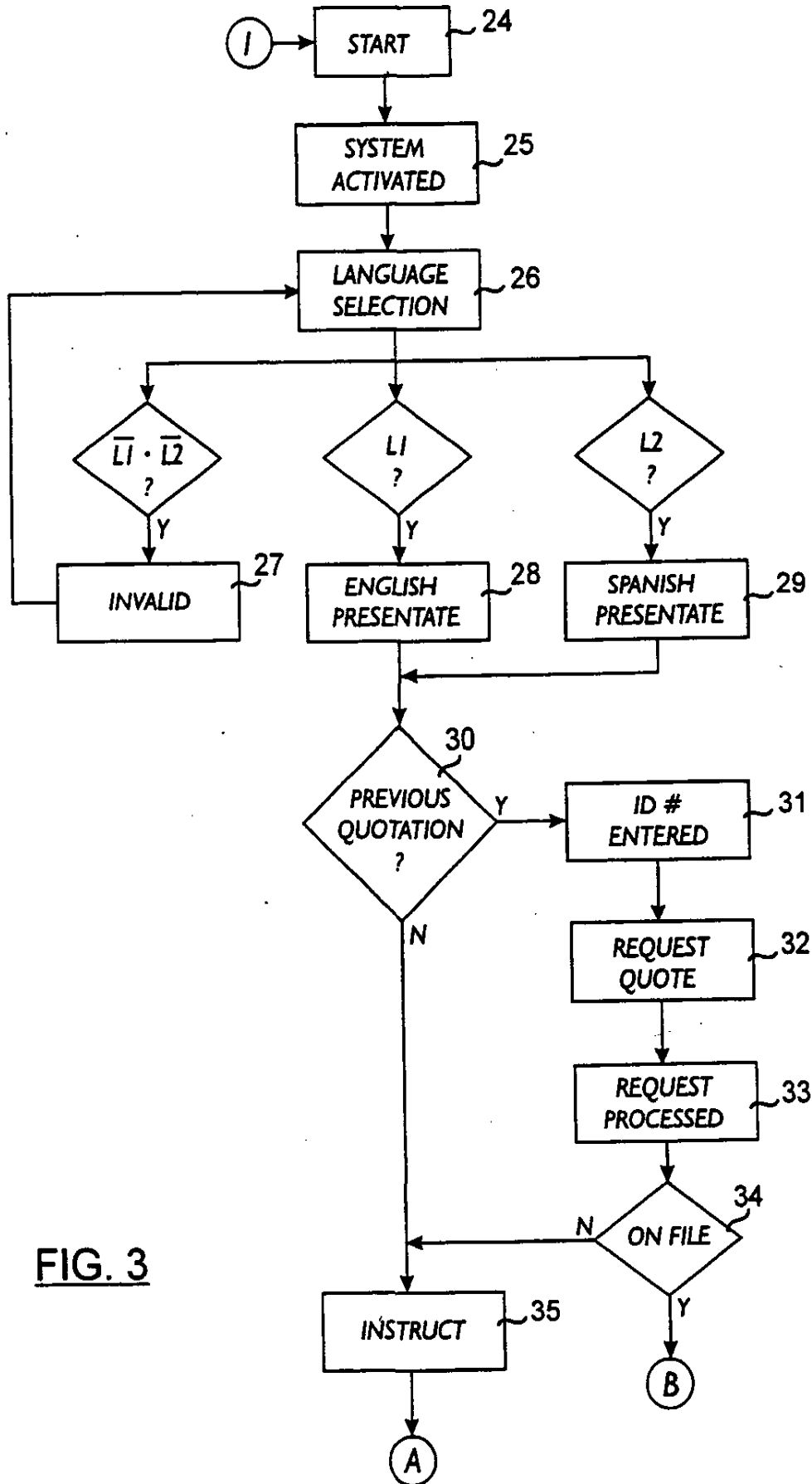

FIG. 3

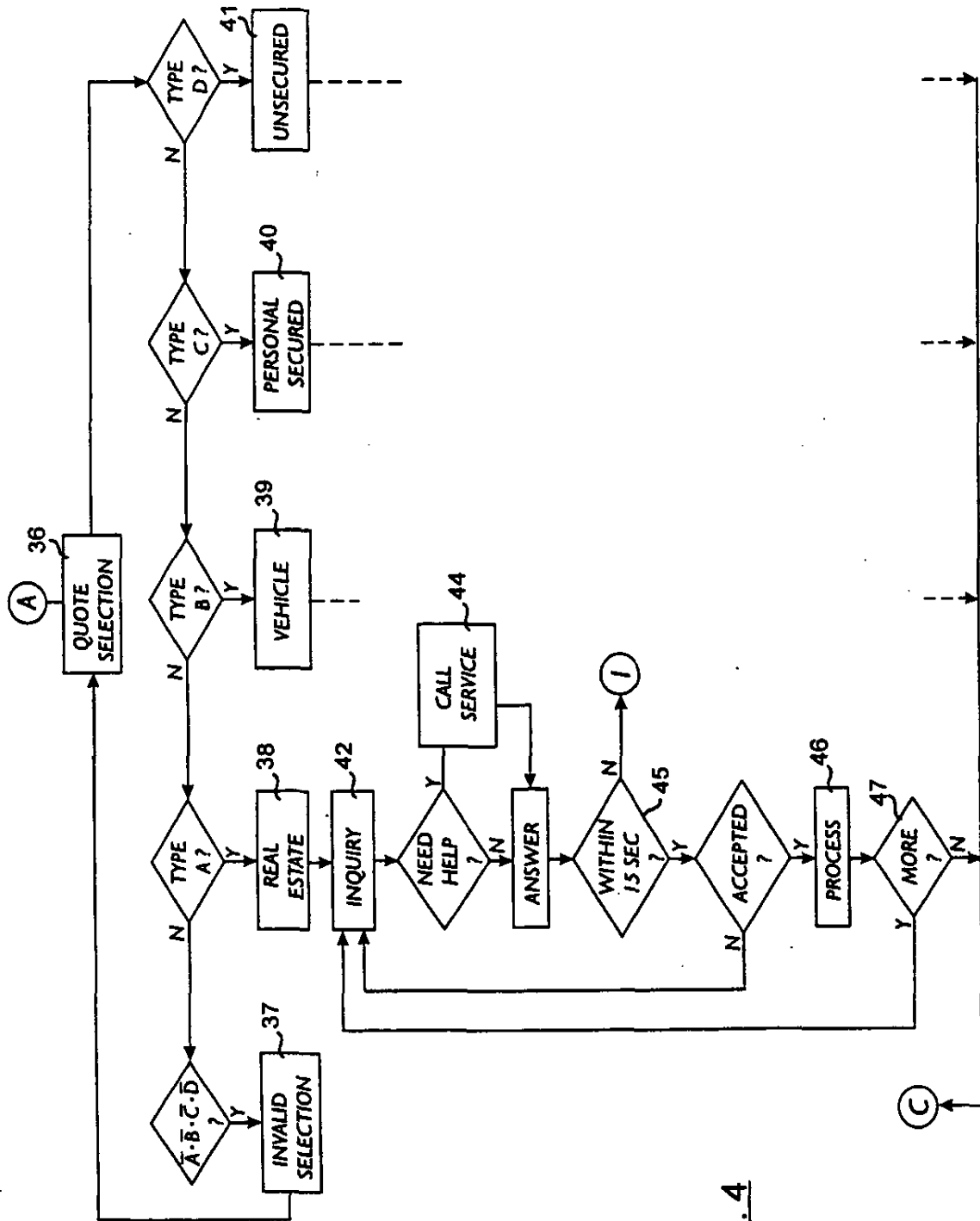

FIG. 4

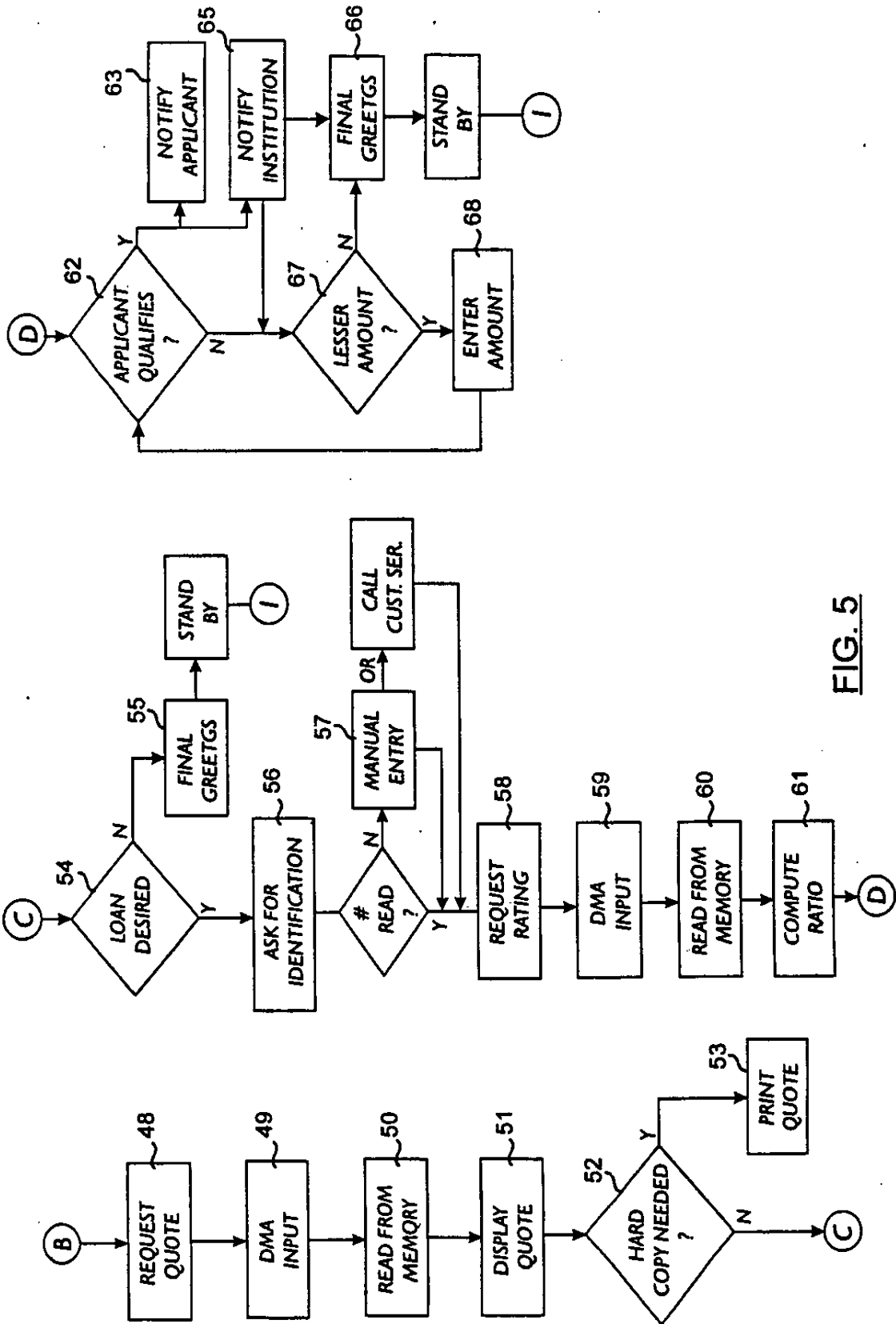

FIG. 5

US 6,289,319 B1

1

AUTOMATIC BUSINESS AND FINANCIAL TRANSACTION PROCESSING SYSTEM

PRIOR APPLICATIONS

This is a continuation application of application Ser. No. 08/096,610 filed Jul. 23, 1993 now abandoned, a continuation application of application Ser. No. 07/752,026 filed Aug. 29, 1991 now abandoned, a continuation of application Ser. No. 07/168,856, filed Mar. 16, 1988 now abandoned, a continuation of application Ser. No. 06/822,115, filed Jan. 24, 1986 now abandoned, which is a continuation-in-part of application Ser. No. 06/613,525 filed May 24, 1984, now U.S. Pat. No. 4,567,359, issued Jan. 28, 1986.

BACKGROUND OF THE INVENTION

The present invention relates to automatic self-operated terminals, vending machines, and interactive data processing networks. More specifically, this invention relates to terminals used by banking institutions to make their services available at all hours of the day from various remote locations.

Loan processing has traditionally been a labor-intensive business which represents the major activity of banks and other financial institutions. In the processing of a loan application, numerous forms have to be filled-out, loan officers have to explain payment schedules and generally guide the applicant through the loan application process. The financial institution then has to process the application and either telephone, mail, or communicate acceptance or rejection of the loan in person to the applicant. The complexity of the process has so far prevented the application of automatic terminals to this important part of financial institution activities. Automatic vending machines and self-service terminals have evolved to a high degree of sophistication as disclosed in U.S. Pat. No. 4,300,040 Gould, et al. and U.S. Pat. No. 4,359,631 Lockwood, et al. Yet, this high degree of sophistication has not been put to use in the more complex types of goods and services distribution which requires a great deal of interaction between individuals and institutions.

SUMMARY OF THE INVENTION

The principal object of this invention is to provide an economical means for screening loan applications. When one considers that up to 75% of persons applying for loans fail to meet the financial institution qualification criteria, one realizes that a great deal of labor is required by loan officers before a qualified applicant presents himself.

Another object of the invention is to standardize the reporting and interpretation of credit ratings and their application to loan application processing.

A further object of the invention is to reduce the amount of paperwork and processing time required by each loan application.

It is also an object of the invention to offer a more personal way to apply for credit. Many applicants who would not hesitate to use a mechanical device to place their inquiry are reluctant to inquire about loans requiring face-to-face interaction with a loan officer.

These and other objects are achieved by means of a system that ties together financial institution data processing, the computer services of a credit reporting bureau, and a plurality of remote terminals. Each remote terminal displays the live image of a fictitious loan officer who helps the applicant through an interactive series of

2

questions and answers designed to solicit from the applicant all the information necessary to process his loan application. The terminal can acquire credit rating information about the applicant from the credit reporting bureau and make a decision based on all the information gathered about the credit worthiness of the applicant and the amount of loan to which he is entitled. The loan amount is then communicated to the applicant and to the financial institution for further processing of the loan.

BRIEF DESCRIPTION OF THE DRAWINGS

FIG. 1 is a general block diagram of the system for automatically processing loan applications;

FIG. 2 is a block diagram showing the major components of the terminal; and

FIGS. 3 to 5 are detailed flow diagrams of the system operation.

DESCRIPTION OF THE PREFERRED EMBODIMENT OF THE INVENTION

Referring now to the drawings, there is shown in FIG. 1 the general block diagram of the automatic loan processing terminal system. The system links a financial institution 1, a plurality of self-service terminals at various remote sites 2 and a credit rating service 3 by telephone lines or other means of telecommunication. The financial institution 1 is provided with a central processor 4 which is used primarily to process loan applications and handle other financial transactions. The central processor 4 has a communication interface which allows it to access the various terminals 5 at the remote sites and be accessed by them at any time of the day. A communication control unit 6 associated with the central processor 4 assures an orderly sending and receiving of information between the terminals and the central processor. The communication control unit 6 provides for a quick transfer of batches of information to and from the terminals 5 under direct access memory mode. Direct access memory modes are achieved by means of high speed data exchange units such as those manufactured by Metacomp, Inc. of San Diego, Calif. and sold under the mark METAPAKS. The central processor 4 is also provided with a terminal monitor and update unit 7 which is programmed for periodically polling the various terminals 5 in order to verify their status and proper operation and to update the data stored in those terminals as may be required. The memory 8 of the central processor 4 holds some files 9 in which are stored information about the various loans available to customers from the institution. This information includes loan rates and repayment schedules. These loans include real estate loans, loans to finance the purchase of automobiles, boats and other vehicles, personal loans secured by certificates of deposit, stocks and other assets controlled by the financial institution 1 and unsecured personal loans. Loan packages which have been quoted to customers are stored in a quoted case file 10 pending acceptance and execution by the applicant. Once a loan has been approved and accepted it is processed and monitored through and active case file 11. The credit rating service 3 is an institution such as TRW CREDITIAL SERVICE which maintains financial files of consumers based on past and current loan payment obligations, credit card uses and balance sheets provided as part of loan applications, and makes that information available to a membership of merchants and financial institutions who need to access the credit worthiness of a particular customer. The credit rating service information is processed automatically by a data processor 12 equipped with auto-

US 6,289,319 B1

3

matic communication interface. This interface allows direct access through telephone lines or other communication networks by any subscribing member. The confidentiality of the credit rating service files is guaranteed by use of identifying codes which must be provided with each request.

The system operates as follows. The central processor 4 of the financial institution 1 periodically sends to the terminals 5 at the various remote sites 2 loan rate information and other data pertinent to the loans available from that institution which are extracted from the loan rate file 9. That information is stored in the various terminals and can be reviewed by an applicant in need of a loan. Once the applicant has selected a type of loan which is available from the institution, he is asked to provide the pertinent personal information data which will be necessary to process his loan application. The information provided by the applicant is supplemented by a financial profile obtained directly from the credit rating service after being automatically requested by the terminal 5. The terminal 5 is programmed to compute the credit worthiness of the applicant and to approve or disapprove the loan. Once the loan has been approved the applicant is requested to accept it or reject it. Accepted loan information is transmitted to the central processor of the financial institution and stored in the active case file 11. Information about loans which have not been accepted on the spot, are also transmitted to the financial institution and stored for a period of time in the quoted case file 10. The customer can return to one of the terminals and accept that loan anytime during the validity period.

Turning now to FIG. 2, there is shown a block diagram of the various components of a terminal 5. The operation of the terminal is controlled by a data processor 13. To the left of the processor, various blocks represent the peripheral equipment which interfaces with the applicant. To the right of the processor there is shown a videodisc 14 on which are stored all the permanent data necessary for the operation of the terminal including the data necessary to effectuate the interactive and automatic request of information by the terminal from the applicant. A modem 15 provides a two-way communication channel with the financial institution 1 and the credit rating service 3. The modem is controlled by the data processor 13 and handles a batch of information through a direct memory access unit 16, to and from a RAM memory 17. Thus, the RAM memory can be used to hold data obtained from the loan rate files 9 at the financial institution as well as applicant's financial profiles obtained from the credit rating service 3. The RAM memory can also be used to store some of the operating routines necessary for the operation of the terminal.

Communication with the applicant is done mainly through the video screen 18. The video screen 18 displays the picture of a fictitious loan officer who informs the applicant about the various types of loans available as well as the manner in which the application can be filed. The applicant answers the request of a loan officer by means of a touch pad 19 or a keyboard. Any entry made by the applicant on the touch pad 19 is processed and orally repeated immediately by means of a voice synthesizer 20 and loud speaker 21. The oral expression of the answers provided by the applicant is a way to assure that no false entry is made. A magnetic strip reader 22 may be provided so that the applicant can give an account number or an identification by means of a credit card. A printer 23 is used to deliver to the applicant a hard copy of any loan quotation as well as a confirmation of his accepted loan.

FIG. 3 is a flow diagram of the system operation during the initial phase of the loan application process. The start 24

4

of system operation is triggered either by the applicant pushing a start button or by the automatic detection of his presence in front of the terminal. Once the system is activated 25 the recording of an image and sound of a fictitious loan officer is read from the videodisc 14 and appears on the video screen 18. The fictitious loan officer takes the applicant through a language selection routine 26-29. In this case, the applicant is asked in both English and Spanish in what language the loan transaction is to be conducted. In this phase of the operation as well as all interactive communications between the loan officer and the applicant, the loan officer explains to the applicant how to enter his answer by means of the touch pad 19. The applicant is then asked whether a previous quotation has already been prepared for him 30. In the affirmative, he is then requested 31 to enter a pass number or identification number either by entering the number on the touch pad or by running his credit I.D. card through the strip reader 22. The terminal then addresses the financial institution and requests 32 the prior loan quotation stored in the quoted case file 10 of the central processor 4. This is done by the data processor 13 of the terminal dialing the institution phone number through the modem 15 and sending a request message. The terminal goes into a standby mode with its DMA unit 16 waiting for a transfer of information from the line into the RAM memory 17. The continued operation depends on whether or not the previous quotation is found 34 to be on file. If the answer is negative, the fictitious loan officer instructs 35 the applicant how to proceed to apply for a loan. In the case where a previous quotation is found to be on file, that quotation is transferred to the terminal according to the program routine B illustrated in FIG. 5.

FIG. 4 is the flow diagram of the system operation during the acquisition of information by the terminal from the applicant. The applicant is first asked to select 36 the type of loan in which he is interested. In this case, he is offered a menu allowing him to choose between a real estate loan 38, a vehicle loan 39, a personal loan 40 secured by an asset held by the financial institution or a personal unsecured loan 41. Any invalid selection 37 triggers a new request. Once a type of loan has been selected, a real estate loan for example, the fictitious loan officer asks a series of inquiries corresponding to the questions that would be found on a standard loan application form. For each question, the system performs a subroutine 42-45 designed to guarantee proper input of the information into the terminal memory 17. If a problem develops during the question and answer period, the applicant is invited to call 44 the loan service at the financial institution. If the answer to a question is not received within fifteen seconds 45, the process of application is presumed to have been abandoned by the applicant and the system returns to its initial standby state. Once all the proper answers have been accepted, they are processed 46 by the terminal data processor 13. This process may involve analyzing certain key answers in order to identify any element or data that would automatically disqualify the applicant. Depending upon the result of that first analysis, more questions 47 may be presented to the applicant in order to refine the data necessary for a thorough assessment of his qualifications.

Turning now to FIG. 5, the B subroutine used to receive a previous quotation from the financial institution is illustrated in the first flow diagram. Once the previous quotation is requested 48 the DMA unit 16 of the terminal is allowed to receive a batch of information containing the previous quotation. This batch of information is stored in the RAM memory 17 from where it is fetched 50 and displayed 51 on

US 6,289,319 B1

5

the video screen 18. The applicant is then asked if he wants a hard copy 52 of the quotation. In the affirmative, the previous quotation is printed 53 on printer 23. The second flow diagram corresponds to the acquisition of the applicant's financial profile from the credit rating service 3. Once a loan quotation has been presented to thus applicant he is asked whether or not he wants to apply for the loan 54. If his answer is negative, the fictitious loan officer expresses final greetings 55. The loan quotation, if not already in storage at the financial institution, is transmitted there for temporary storage in the quoted case file 10 of the central processor 4. If the applicant wishes to apply for the loan, he is asked to provide a password or identification 56 which will allow the terminal to access his file at the credit rating service 3. As previously explained, this number can be entered directly by means of an identification card run through the strip reader 22 or entered manually 57 by means of the touch pad 19. The terminal requests a rating 58 from the credit rating service 3 in a manner similar to the one used and described previously for obtaining a previous quotation from the financial institution. The applicant's financial profile is received as a batch of information through the DMA unit 59 and then read from the memory 60. The financial profile is then analyzed by the terminal in order to compute 61 a debt ratio or other criterion devised by the financial institution to access the credit worthiness of the applicant. The debt ratio is the ratio of the applicant's current expenses to his current income. Other parameters such as debt to equity ratio or fixed assets to debt may be computed by the terminal data processor 13 and used in determining the qualifications of the applicant. It should be noted that the entire decision whether or not to grant the loan is performed automatically and onsite by the terminal 5 without intervention whatsoever from any of the financial institution personnel, except in case of a breakdown in communications by requesting a direct phone call by the applicant to the financial institution.

The last flow diagram on the drawing represents the final phase of the loan application transaction. Once the terminal equipment has determined that the applicant qualifies 62 for the loan, the applicant is so notified 63, and instructed how to obtain the loan funds. The institution is also notified 65, and the loan is processed through the active case file 11 by the central processor 4. The fictitious loan officer closes the transaction by giving his final greetings 66 before the system is returned to a standby condition. If the applicant does not qualify for the amount of loan requested, he is first asked whether a lesser amount 67 would be acceptable to him. He is then instructed to enter the lesser amount 68 through the touch pad 19. That new amount is then checked against the determination already made by the terminal. The process is repeated until an acceptable amount is requested by the applicant, or until such time as the applicant declines to proceed with the loan application.

It should be noted that the system as described could be applied to other forms of transactions in which information has to be acquired from a customer then processed to a decision or into the performance of a particular task. A similar system could be used, for instance, for the preparation and filing of income tax returns. In such case, the assistance that the fictitious person who appears on the video screen can give to the applicant in filling-out the tax form can be easily programmed on the videodisc.

Other applications of the system include the selection and purchase of stocks and other securities, the selection and opening of so-called "self-directed investments" such as Individual Retirement Accounts, and other complex transactions which normally require a great deal of time and attention on the part of the officers of an institution.

6

While the preferred embodiment of the invention has been described and other modifications have been suggested, other embodiments may be devised without departing from the spirit of the invention and the scope of the appended claims.

What is claimed is:

1. An automatic data processing system for processing business and financial transactions between entities from remote sites which comprises:

a central processor programmed and connected to process a variety of inquiries and orders transmitted from said remote sites;

said central processor including:

means for receiving information about said transactions from said remote sites;

means for retrievably storing said information;

at least one terminal at each of said remote sites including a data processor and operational sequencing lists of program instructions;

means for remotely linking said terminal to said central processor and for transmitting data back and forth between said central processor and said terminal; said terminal further comprising means for dispensing information and services for at least one of said entities including:

a video screen;

means for holding operational data including programing, informing, and inquiring sequences of data;

means for manually entering information;

means for storing information, inquires and orders for said transactions entered by one of said entities via said means for manually entering information, and data received through and from said central processor;

on-line means for transmitting said information, inquiries, and orders to said central processor;

on-line means for receiving data comprising operator-selected information and orders from said central processor via said linking means;

means for outputting said informing and inquiring sequences on said video screen in accordance with preset routines and in response to data entered through said means for entering information;

means for controlling said means for storing, means for outputting, and means for transmitting, including means for fetching additional inquiring sequences in response to a plurality of said data entered through said means for entering and in response to information received from said central processor;

said informing sequences including directions for operating said terminal, and for presenting inter-related segments of said operational data describing a plurality of transaction operations;

said programming sequences including means for inter-actively controlling the operation of said video screen, data receiving and transmitting means; and for selectively retrieving said data from said means for storing;

said means for storing comprising means for retaining said operational sequencing list and means responsive to the status of the various means for controlling their operation;

said central processor further including:

means responsive to data received from one of said terminals for immediately transmitting selected stored information to said terminal; and

US 6,289,319 B1

7

means responsive to an order received from a terminal for updating data in said means for storing; whereby said system can be used by said entities, each using one of said terminals to exchange information, and to respond to inquiries and orders instantaneously and over a period of time.

2. The system of claim 1, wherein said terminal further comprises means for generating a personal qualification report including means for determining the type and amount of goods or services which can be provided to an entity wherein said means for determining comprises means for mathematically processing said information entered through said means for entering.

8

3. The system of claim 1, wherein said inquiring and informing sequences of data comprise textual and graphical data.

4. The system of claim 3, wherein said means for outputting further comprise means for generating audible informing and inquiring messages.

5. The system of claim 4, wherein said means for outputting further comprise means for synchronizing said audible messages with said textual and graphical data.

6. The system of claim 3, wherein said means for holding comprise an optical disc.

* * * * *