

IN THE UNITED STATES DISTRICT COURT  
FOR THE DISTRICT OF DELAWARE

QUINSTREET, INC.,

Plaintiff,

v.

PARALLEL NETWORKS, LLC.,

Defendant.

Civil Action No. 06-495-SLR

Honorable Sue L. Robinson

**SECOND AMENDED COMPLAINT FOR DECLARATORY JUDGMENT**

Plaintiff QuinStreet, Inc. (“QuinStreet”) for its amended complaint against Defendant Parallel Networks, LLC (“Parallel Networks”), hereinafter referred to as (“Defendant”) alleges as follows:

**THE PARTIES**

1. Plaintiff QuinStreet, Inc. is a corporation organized and existing under the laws of the State of California, having its principal place of business located at Foster City, California 94404.

2. Defendant Parallel Networks is a limited liability company organized under the laws of the State of Texas, having its principal place of business at 1700 Pacific Avenue, Suite 2320, Dallas, Texas 75201.

**JURISDICTION AND VENUE**

3. This is a complaint for declaratory relief under the patent laws of the United States. This Court has subject matter jurisdiction over this action pursuant to 28 U.S.C. §§ 1331, 1338(a), 2201(a) and 2202.

4. This Court has personal jurisdiction over Parallel Networks by virtue of its joinder in filing of Defendant’s Opposition to Plaintiff’s Motion For Leave to File Amended Complaint

For Declaratory Judgment in this action and by joint stipulation to its substitution as a defendant for epicRealm.

5. Venue is proper in this judicial district pursuant to 28 U.S.C. §§ 1391(b), (c) and 1400(b).

### **THE EPICREALM PATENTS**

6. U.S. Patent No. 5,894,554 (the “554 patent”) issued on April 13, 1999 and is entitled “System for Managing Dynamic Web Page Generation Requests by Intercepting Request at Web Server and Routing to Page Server Thereby Releasing Web Server to Process Other Requests.”

7. U.S. Patent No. 6,415,335 (the “335 patent”) issued on July 2, 2002 from a division of U.S. Patent Application No. 08/636,477, now the ‘554 patent, and is entitled “System and Method for Managing Dynamic Web Page Generation Requests.”

8. Parallel Networks asserts that it is now or has been previously the owner and assignee of the ‘554 and ‘335 patents (the “epicRealm patents” or “Defendant’s patents”) and that it has the right to enforce the epicRealm patents against QuinStreet. Copies of the epicRealm patents or “Defendant’s patents” are attached hereto as Exhibits A and B.

9. Parallel Networks asserts that it is now the present owner and assignee of the epicRealm patents and that it has the right to enforce the epicRealm patents against QuinStreet and to recover for past, current and future alleged infringement.

### **EPICREALM’S AND PARALLEL NETWORK’S PATENT INFRINGEMENT LAWSUITS**

10. On April 15, 2005, epicRealm, then known as epicRealm Licensing, LLC, filed a patent infringement complaint in the District Court for the Eastern District of Texas (Marshall Division) accusing defendant Speedera Networks, Inc. of infringing the epicRealm patents “by

making and using network infrastructures that manage dynamic Web page generation requests that infringe one or more of the claims set forth in the epicRealm patents”. That action was assigned Civil Action No. 2:05-CV-150DF (the “Speedera action”) and was originally assigned to United States District Court Judge David Folsom. This case has been resolved by settlement.

11. On May 2, 2005, epicRealm, then known as epicRealm Licensing, LLC, filed a patent infringement complaint in the District Court for the Eastern District of Texas (Marshall Division) accusing defendants Autoflex Leasing, Inc., eHarmony.com, Inc., Friendfinder Network, Inc., Grande Communication Networks, Inc., IJL-NCP, LLC and Transplace Texas, LP of infringing the epicRealm patents. That action was assigned Civil Action No. 2:05-CV-163 (the “163 action”) and was originally assigned to United States District Court Judge T. John Ward. On June 10, 2005, epicRealm filed a First Amended Complaint in the ‘163 action.

12. On August 5, 2005, epicRealm filed a patent infringement complaint in the District Court for the Eastern District of Texas (Marshall Division) accusing defendants Franklin Covey Co., Clark Consulting, Inc., The Macerich Company, Safelite Group, Inc., Herbalife International of America, Inc. and Pink Sheets, LLC of infringing the epicRealm patents. That action was assigned Civil Action Number 2:05-CV-356 (the “356 action”) and was originally assigned to United States District Court Judge T. John Ward. On November 2, 2005, epicRealm filed a First Amended Complaint in the ‘356 action.

13. On November 2, 2005, Judge Ward consolidated the ‘163 and ‘356 actions (the “Consolidated epicRealm Actions”).

14. On November 9, 2005 and November 16, 2005 the Consolidated epicRealm Actions were reassigned to United States District Judge David Folsom.

15. On January 27, 2006, epicRealm filed a Second Amended Complaint in the

Consolidated epicRealm Actions accusing defendants Autoflex Leasing, Inc., eHarmony.com, Inc., Friendfinder Network, Inc., Grande Communications Networks, Inc., Transplace Texas, LP, Franklin Covey Co., Clark Consulting, Inc., Macerich Company, Safelite Group, Inc., Herbalife International of America, Inc. and Pink Sheets, LLC of infringing the epicRealm patents.

16. On April 13, 2007, epicRealm filed its Answer and Counterclaim alleging patent infringement in this action in the District Court for the District of Delaware Civil Action No. 06-495-SLR (the "Counterclaim") assigned to United States District Court Judge Sue L. Robinson accusing defendant Quinstreet, Inc. of infringing the epicRealm patents.

17. On October 2, 2007, Parallel Networks, as the new real party in interest, filed Defendant's Opposition to Plaintiff's Motion For Leave to File Amended Complaint For Declaratory Judgment which informed the Court and the parties of the recent transaction between epicRealm and Parallel Networks.

**PARALLEL NETWORK'S PATENT INFRINGEMENT ACCUSATIONS  
AND QUINSTREET'S REASONABLE APPREHENSION OF SUIT**

18. In its Second Amended Complaint in the Texas actions and the Counterclaim filed herein, epicRealm and now Parallel Networks alleges that adverse parties named therein infringe the epicRealm patents because they use systems and methods for managing requests for dynamic web pages falling within the claims of its patents.

19. QuinStreet operates systems for responding to requests for static and dynamic web pages and maintains hosting platforms for customers. QuinStreet has entered into web site hosting agreements with many customers.

20. Herbalife International of America, Inc. ("Herbalife"), a defendant in the '356 action, is one such customer of QuinStreet.

21. Herbalife has asserted that its agreement with QuinStreet entitles it to a defense

and indemnification from QuinStreet if it is accused of infringing a third party's intellectual property rights, and Herbalife has demanded that QuinStreet agree to defend and indemnify Herbalife from any and all claims asserted by epicRealm or Parallel Networks.

22. In the '356 action epicRealm contends that its patents must be broadly construed to cover virtually all systems and methods wherein dynamic web page requests are intercepted at a web server or other HTTP-compliant device and transferred to page server software capable of processing dynamic web pages. According to epicRealm, "[w]eb servers, caching servers, and layer-7 switches are types of HTTP-compliant devices. Web requests are initially evaluated by the HTTP-compliant device. The requests for dynamic content ... are transferred to the page server(s) (or application server, servlet container or software, etc) such as Tomcat, J-Boss, and/or Resin for processing." Per epicRealm, any system and method incorporating these or similar elements, along with releasing of the HTTP-compliant device to concurrently process other requests, violates its patents.

23. In correspondence to Clark Consulting Inc. ("Clark"), a defendant in the '356 action, epicRealm confirmed this position and advised that its contentions of patent infringement were not confined to any particular web site software or architecture, and asserted that other systems or methods employing server software "could, if used to generate web pages with dynamic content, be configured in a way that would infringe the claims of the epicRealm patents." The January 25, 2006 letter from epicRealm to Clark (the "epicRealm Letter") is attached hereto as Exhibit C.

24. QuinStreet employs several systems and methods for dynamic web page generation wherein dynamic web page requests are transferred from a web server to other server software for processing that would fall within the ambit of the claims of epicRealm's patents as

those are interpreted by epicRealm and Parallel Networks. In the '356 action epicRealm is requiring Herbalife to provide discovery disclosures to epicRealm and Parallel Networks regarding QuinStreet's use of its server software for generating web pages.

25. One of QuinStreet's customers which is not a party to any litigation brought by epicRealm or Parallel Networks has informed QuinStreet that in view of the '356 action, it is canceling its contract with QuinStreet pursuant to which QuinStreet provides it dynamic web page generating services.

26. epicRealm's patent infringement allegations in the Speedera action and in the Consolidated epicRealm Actions against Herbalife and others, its very broad interpretation of the reach of its patents' claims as exemplified in its infringement contentions and the epicRealm Letter, and epicRealm's demand for discovery of QuinStreet information from Herbalife caused QuinStreet to have a reasonable apprehension that (1) epicRealm will accuse QuinStreet, QuinStreet's products and/or QuinStreet's customers of infringing one or more claims of the epicRealm patents, and/or (2) additional QuinStreet customers will seek from or sue QuinStreet for indemnity as a result of epicRealm's patent infringement claims; and/or (3) additional QuinStreet customers will seek to terminate their contracts with QuinStreet in view of the '356, the '163, and the Speedera actions or other subsequent claims by epicRealm that systems similar to those hosted by QuinStreet infringe epicRealm's patents. Following the institution of this action, QuinStreet's reasonable apprehensions were realized by virtue of the filing of the Counterclaim by epicRealm and its assignment to Parallel Networks.

**FIRST CLAIM FOR RELIEF**  
**(Declaratory Judgment of Noninfringement of Defendant's Patents)**

27. QuinStreet incorporates by reference Paragraphs 1 through 23 above.

28. By virtue of epicRealm's patent infringement allegations in the Speedera action

and in the Consolidated epicRealm Actions against Herbalife and others, the epicRealm Letter, epicRealm's demand for discovery of QuinStreet information from Herbalife, and the actual loss of business by QuinStreet due to a customer's patent infringement concerns, and the reasonable apprehension of additional such losses and the filing of the Counterclaim, an actual controversy exists between QuinStreet and Defendant as to whether QuinStreet, QuinStreet's products and/or one or more QuinStreet customers infringe the epicRealm patents.

29. QuinStreet has not infringed and does not infringe, literally or under the doctrine of equivalents, either directly, indirectly or willfully, any valid and enforceable claim of the Defendant's patents.

30. Pursuant to 28 U.S.C. §§ 2201 and 2202, a judicial determination of the respective rights of the parties with respect to QuinStreet's noninfringement of the Defendant's patents as alleged by Parallel Networks in the Counterclaim is necessary and appropriate under the circumstances.

**SECOND CLAIM FOR RELIEF**  
**(Declaratory Judgment of Invalidity of Defendant's Patents)**

31. QuinStreet incorporates by reference Paragraphs 1 through 27 above.

32. By virtue of Defendant's patent infringement allegations in the Speedera action and in the Consolidated epicRealm Actions against Herbalife and others, the epicRealm Letter, epicRealm's demand for discovery of QuinStreet information from Herbalife, the actual loss of business by QuinStreet due to a customer's patent infringement concerns, the reasonable apprehension of additional such losses and the filing of the Counterclaim, an actual controversy exists between QuinStreet and Defendant as to the validity of the Defendant's patents.

33. Each claim of the Defendant's patents is invalid for failure to meet one or more of the conditions of patentability specified in 35 U.S.C. §§ 101, 102, 103 and/or 112.

34. Pursuant to 28 U.S.C. §§ 2201 and 2202, a judicial determination of the respective rights of the parties with respect to the validity of the Defendant's patents is necessary and appropriate under the circumstances.

**THIRD CLAIM FOR RELIEF**  
**(Declaratory Judgment of Unenforceability of Defendant's Patents)**

35. QuinStreet incorporates by reference Paragraphs 1 through 34 above.

36. On information and belief, Defendant's patents are unenforceable because one or more of the Parallel Networks inventors, patentees and their attorneys engaged in inequitable conduct during the prosecution of the patents-in-suit in the USPTO.

37. Particularly, prior to September 1, 1995, Keith Lowery, a named inventor, researched and had knowledge of material prior art relating to Oracle web server products that had been described in publications, offered for sale, sold and made available to the public, prior to the conception and reduction to practice of the claimed inventions of the patents-in-suit.

38. Keith Lowery, the other named inventors, the patentee, and the prosecuting attorneys of the patents-in-suit failed to submit the material prior art to the USPTO during the prosecution of the patents-in-suit in violation of 37 C.F.R. §1.56. This failure to disclose material prior art was intended to deceive the USPTO.

39. In addition, prior to the issuance of the patents-in-suit, the attorneys responsible for prosecuting the patents-in-suit, including Jim Salter and Sharmine Green of the law firm Blakely, Sokoloff, Taylor and Zafman, LLP had knowledge of additional material prior art, including but not limited to the prior art methods and apparatus described in U.S. Patent No. 5,761,673 issued to Oracle and the prior art references cited therein.

40. The prosecuting attorneys failed to submit the 673 patent and references cited therein to the USPTO during the prosecution of the patents-in-suit in violation of 37 C.F.R.



§1.56. The failure to disclose material prior art was intended to deceive the USPTO.

41. QuinStreet hereby gives notice that discovery is still ongoing as of the date of this Second Amended Complaint, and QuinStreet intends to adduce additional inequitable conduct evidence that may be discovered during the remainder of fact discovery, including, but not limited to, facts that may be discovered from depositions of the named inventors of Defendant's patents, the prosecuting attorneys, and any other person that had substantive involvement in the prosecution of Defendant's patents.

**PRAYER**

WHEREFORE, QuinStreet requests entry of judgment in its favor and against Defendant Parallel Networks as follows:

a. Declaring that QuinStreet and its software products, including but not limited to Microsoft software products, that are used in conjunction with the delivery of dynamic web pages do not infringe, literally or under the doctrine of equivalents, either directly, indirectly or willfully, any valid and enforceable claim of the Defendant's patents;

b. Declaring that the claims of the Defendant's patents are invalid;

c. Declaring that Defendant's patents are unenforceable due to inequitable conduct;

d. Decreeing this case an "exceptional case" within the meaning of 35 U.S.C. § 285 and awarding reasonable attorneys' fees to QuinStreet; and

e. Awarding QuinStreet such other costs and further relief as the Court deems just and proper.

  
Robert H. Richards, III (#706)  
rrichards@rlf.com  
Jeffrey L. Moyer (#3309)  
moyer@rlf.com  
Anne Shea Gaza (#4093)  
gaza@rlf.com  
Richards, Layton & Finger  
One Rodney Square  
920 N. King Street  
Wilmington, Delaware 19899-0551  
302-651-7700

Attorneys for Plaintiff QUINSTREET, INC.

OF COUNSEL:

Robert S. Beiser  
Ludwig E. Kolman  
David L. Doyle  
Vedder, Price, Kaufman & Kammholz, P.C.  
222 North LaSalle Street  
Chicago, Illinois 60601  
(312)609.7500  
and

Gordon C. Atkinson  
Cooley Godward LLP  
101 California Street, 5th Flr.  
San Francisco, California 94111  
(415)693.2000

Dated: February 8, 2008



US005894554A

**United States Patent** [19]

[11] **Patent Number:** 5,894,554

Lowery et al.

[45] **Date of Patent:** Apr. 13, 1999

[54] **SYSTEM FOR MANAGING DYNAMIC WEB PAGE GENERATION REQUESTS BY INTERCEPTING REQUEST AT WEB SERVER AND ROUTING TO PAGE SERVER THEREBY RELEASING WEB SERVER TO PROCESS OTHER REQUESTS**

5,452,460 9/1995 Distelberg et al ..... 395/700  
 5,532,838 7/1996 Barbaui ..... 358/400  
 5,751,956 5/1998 Kirsch ..... 395/200 33  
 5,761,673 6/1998 Bookman et al ..... 707/104

**OTHER PUBLICATIONS**

"Beyond the Web: Excavating the Real World Via Mosaic".  
 Goldberg et al. Second International WWW. Oct. 17, 1994.  
 PCT International Search Report. Aug. 21, 1997.

*Primary Examiner*—Thomas C. Lee  
*Assistant Examiner*—Rehana Perveen  
*Attorney, Agent, or Firm*—Blakely, Sokoloff, Taylor & Zafman LLP

[75] **Inventors:** Keith Lowery, Richardson; Andrew B. Levine, Plano; Ronald L. Howell, Rowlett, all of Tex.

[73] **Assignee:** InfoSpinner, Inc., Richardson, Tex.

[21] **Appl. No.:** 08/636,477

[22] **Filed:** Apr. 23, 1996

[51] **Int. Cl.<sup>6</sup>** ..... G06F 13/14; G06F 13/20

[52] **U.S. Cl.** ..... 395/200.33; 395/200.68; 395/200.75; 395/680; 707/10; 707/104

[58] **Field of Search** ..... 358/400; 395/800; 395/700, 200.68, 200.75, 200.53, 680, 200.33; 707/104, 10

[57] **ABSTRACT**

The present invention teaches a method and apparatus for creating and managing custom Web sites. Specifically, one embodiment of the present invention claims a computer-implemented method for managing a dynamic Web page generation request to a Web server, the computer-implemented method comprising the steps of routing the request from the Web server to a page server, the page server receiving the request and releasing the Web server to process other requests, processing the request, the processing being performed by the page server concurrently with the Web server, as the Web server processes the other requests, and dynamically generating a Web page in response to the request, the Web page including data dynamically retrieved from one or more data sources.

[56] **References Cited**

**U.S. PATENT DOCUMENTS**

4,866,706 9/1989 Christophersen et al ..... 370/85.7  
 5,341,499 8/1994 Doragh ..... 395/700  
 5,392,400 2/1995 Berkowitz et al ..... 395/200  
 5,404,522 4/1995 Carmon et al ..... 395/650  
 5,404,523 4/1995 DellaFera et al ..... 395/650  
 5,404,527 4/1995 Irwin et al ..... 395/700

11 Claims, 5 Drawing Sheets

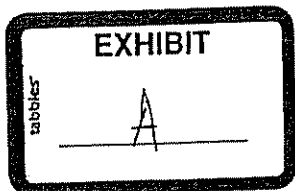
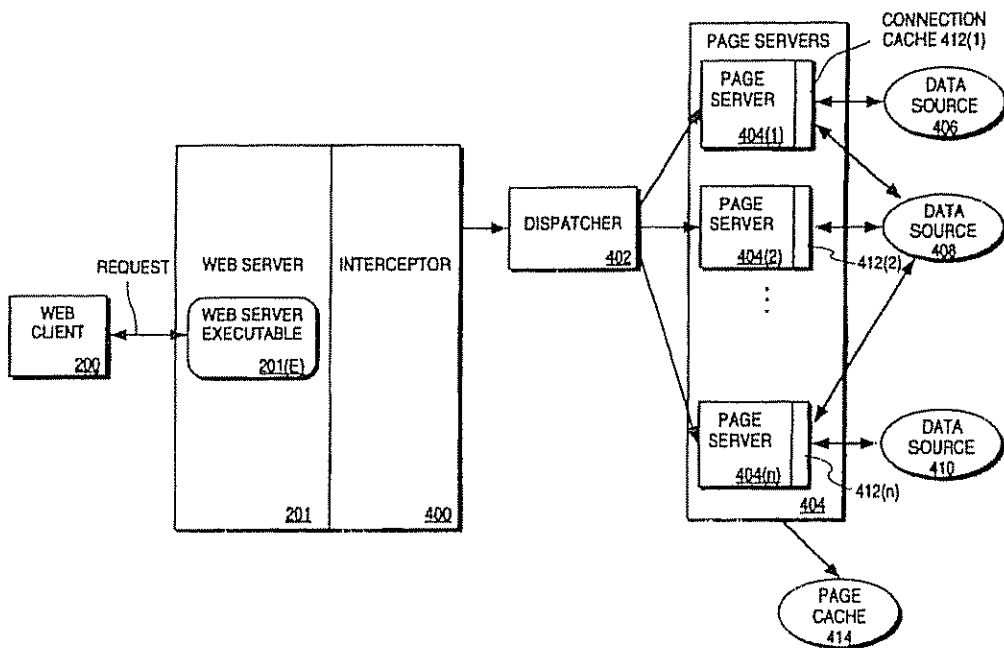

U.S. Patent

Apr. 13, 1999

Sheet 1 of 5

5,894,554

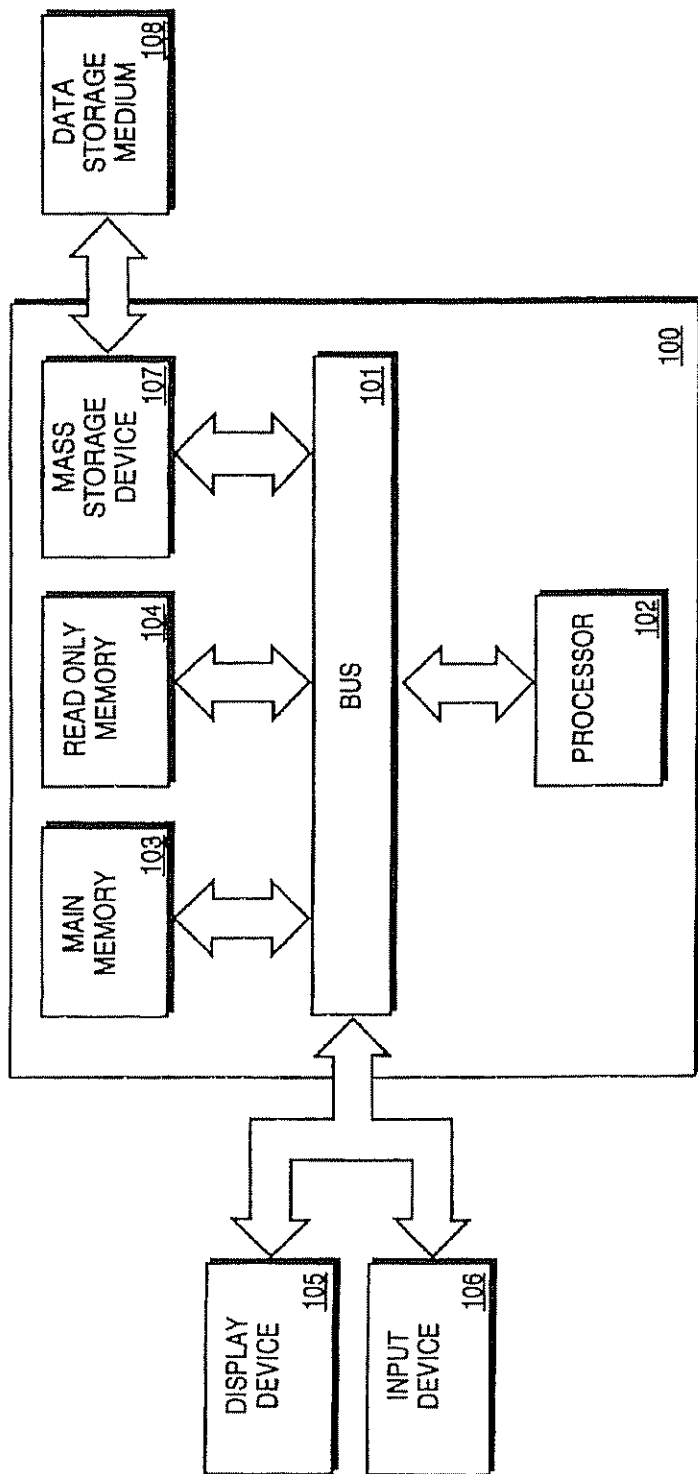
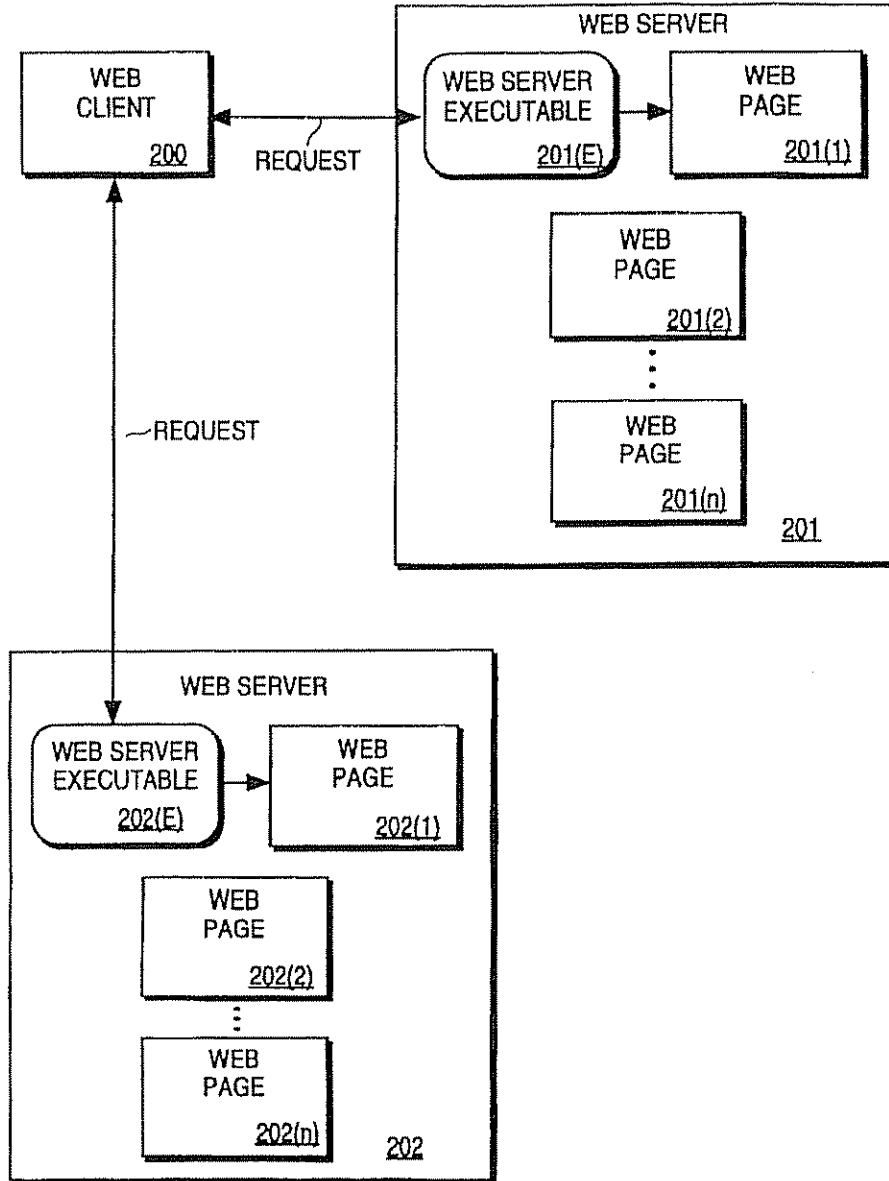

FIG. 1



**FIG. 2** (PRIOR ART)

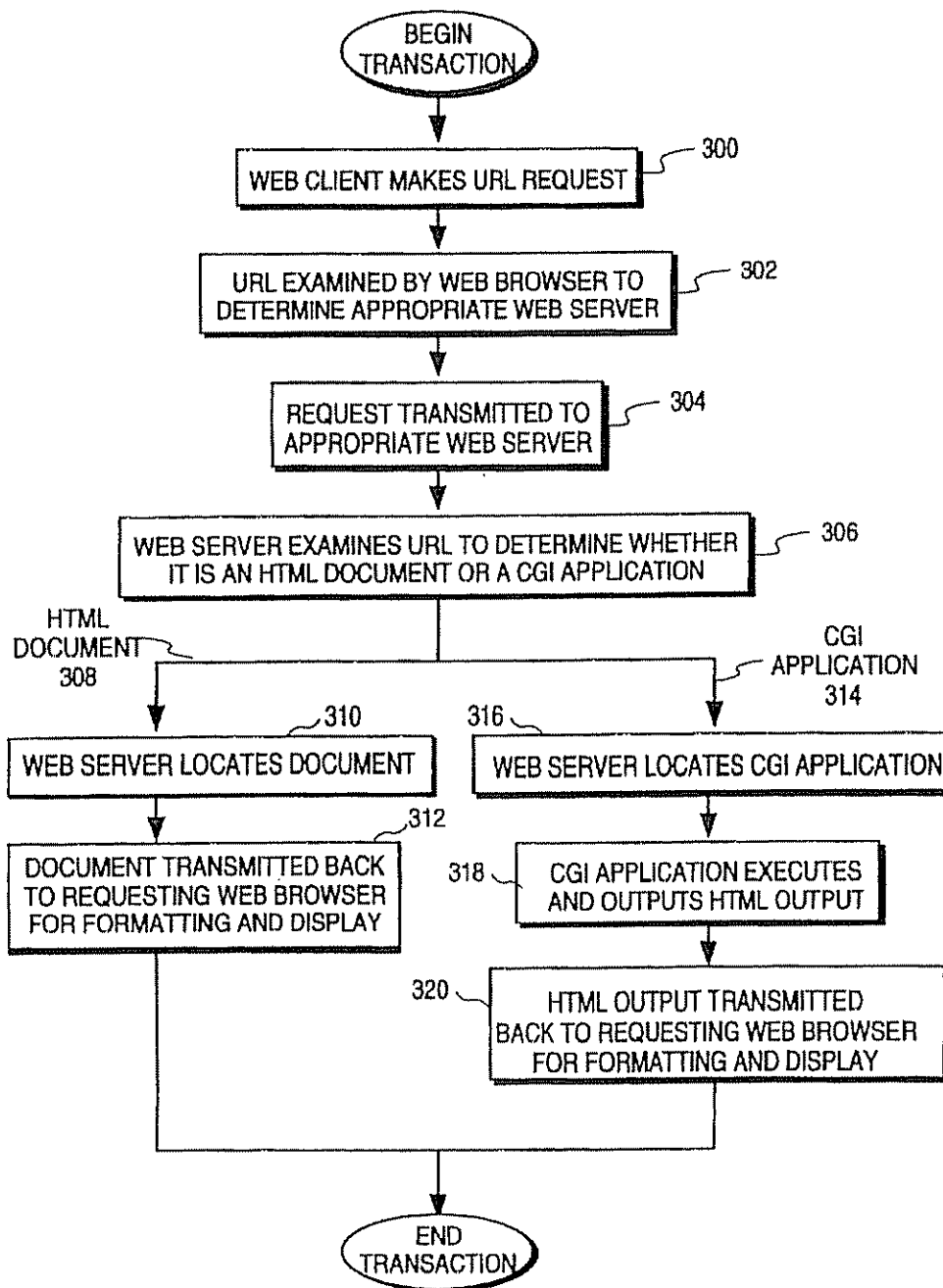

FIG. 3 (PRIOR ART)

U.S. Patent

Apr. 13, 1999

Sheet 4 of 5

5,894,554

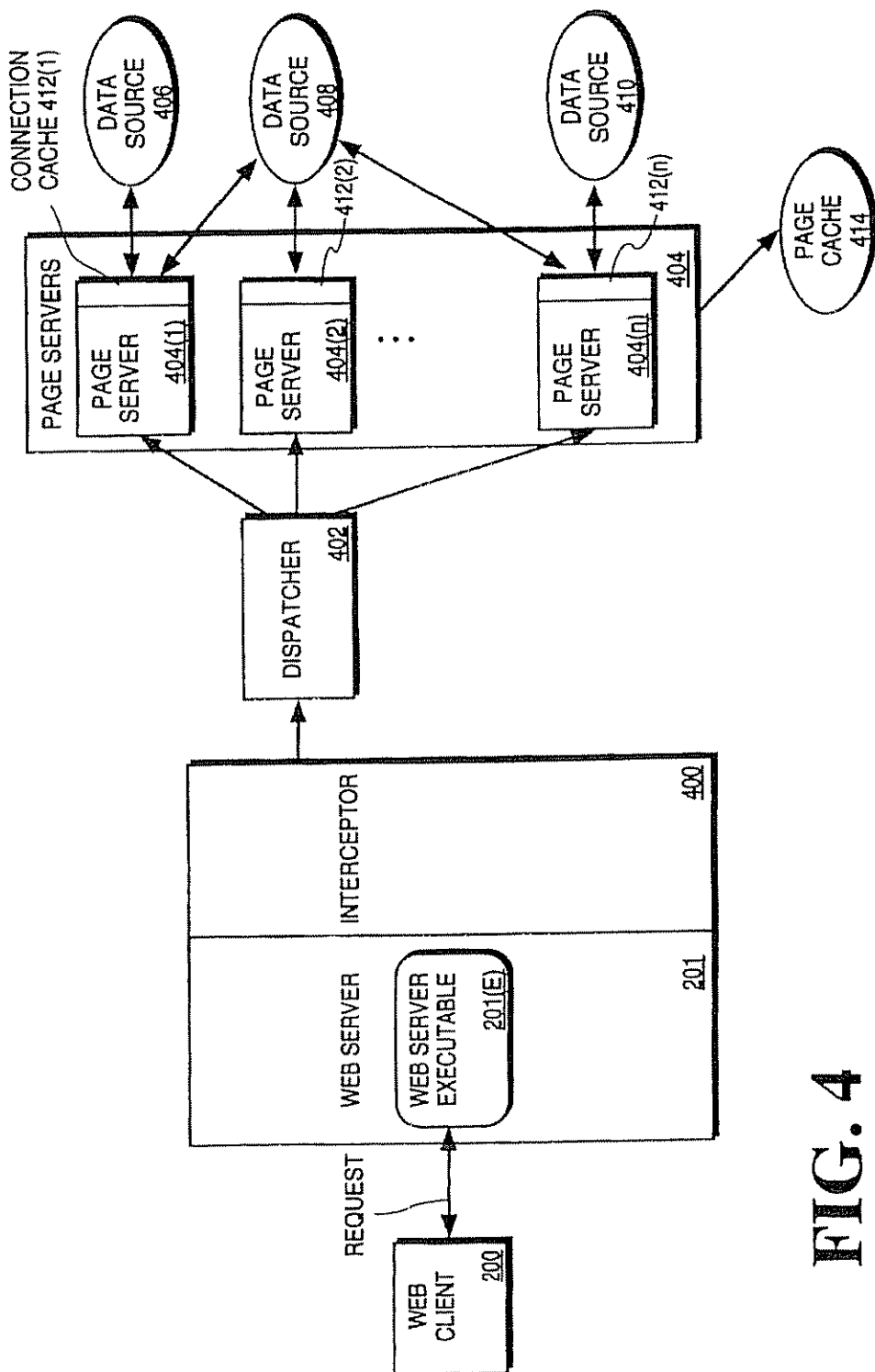

FIG. 4

U.S. Patent

Apr. 13, 1999

Sheet 5 of 5

5,894,554

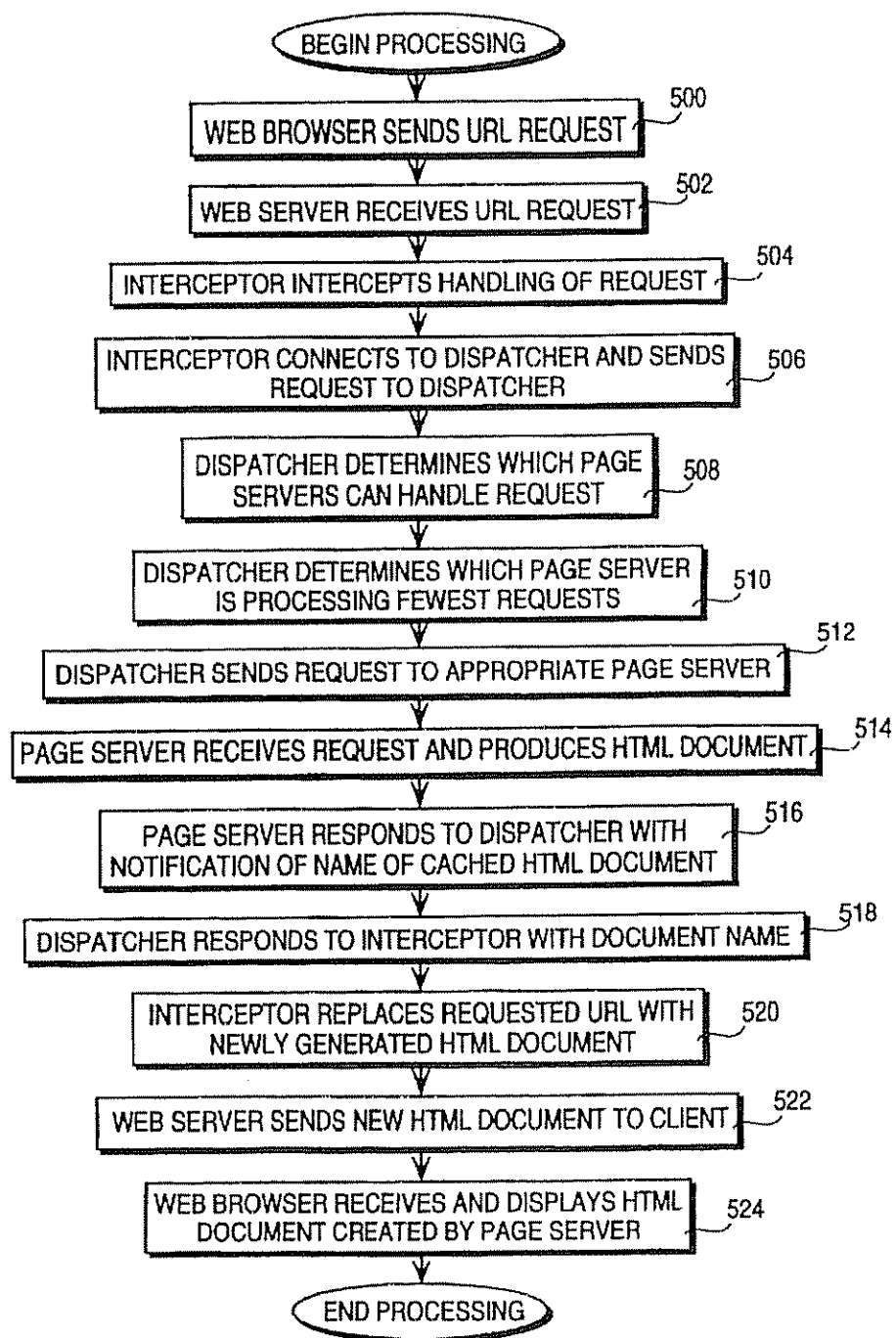
**FIG. 5**



5,894,554

1

**SYSTEM FOR MANAGING DYNAMIC WEB  
PAGE GENERATION REQUESTS BY  
INTERCEPTING REQUEST AT WEB  
SERVER AND ROUTING TO PAGE SERVER  
THEREBY RELEASING WEB SERVER TO  
PROCESS OTHER REQUESTS**

**FIELD OF THE INVENTION**

The present invention relates to the field of Internet technology. Specifically, the present invention relates to the creation and management of custom World Wide Web sites.

**DESCRIPTION OF RELATED ART**

The World Wide Web (the Web) represents all of the computers on the Internet that offer users access to information on the Internet via interactive documents or Web pages. These Web pages contain hypertext links that are used to connect any combination of graphics, audio, video and text, in a non-linear non-sequential manner. Hypertext links are created using a special software language known as HyperText Mark-Up Language (HTML).

Once created, Web pages reside on the Web, on Web servers or Web sites. A Web site can contain numerous Web pages. Web client machines running Web browsers can access these Web pages at Web sites via a communications protocol known as HyperText Transport Protocol (HTTP). Web browsers are software interfaces that run on World Wide Web clients to allow access to Web sites via a simple user interface. A Web browser allows a Web client to request a particular Web page from a Web site by specifying a Uniform Resource Locator (URL). A URL is a Web address that identifies the Web page and its location on the Web. When the appropriate Web site receives the URL, the Web page corresponding to the requested URL is located, and if required, HTML output is generated. The HTML output is then sent via HTTP to the client for formatting on the client's screen.

Although Web pages and Web sites are extremely simple to create, the proliferation of Web sites on the Internet highlighted a number of problems. The scope and ability of a Web page designer to change the content of the Web page was limited by the static nature of Web pages. Once created, a Web page remained static until it was manually modified. This in turn limited the ability of Web site managers to effectively manage their Web sites.

The Common Gateway Interface (CGI) standard was developed to resolve the problem of allowing dynamic content to be included in Web pages. CGI "calls" or procedures enable applications to generate dynamically created HTML output, thus creating Web pages with dynamic content. Once created, these CGI applications do not have to be modified in order to retrieve "new" or dynamic data. Instead, when the Web page is invoked, CGI "calls" or procedures are used to dynamically retrieve the necessary data and to generate a Web page.

CGI applications also enhanced the ability of Web site administrators to manage Web sites. Administrators no longer have to constantly update static Web pages. A number of vendors have developed tools for CGI based development, to address the issue of dynamic Web page generation. Companies like Spider™ and Bluestone™, for example, have each created development tools for CGI-based Web page development. Another company, Haht Software™, has developed a Web page generation tool that uses a BASIC-like scripting language, instead of a CGI scripting language.

2

Tools that generate CGI applications do not, however, resolve the problem of managing numerous Web pages and requests at a Web site. For example, a single company may maintain hundreds of Web pages at their Web site. Current Web server architecture also does not allow the Web server to efficiently manage the Web page and process Web client requests. Managing these hundreds of Web pages in a coherent manner and processing all requests for access to the Web pages is thus a difficult task. Existing development tools are limited in their capabilities to facilitate dynamic Web page generation, and do not address the issue of managing Web requests or Web sites.

**SUMMARY OF THE INVENTION**

It is therefore an object of the present invention to provide a method and apparatus for creating and managing custom Web sites. Specifically, the present invention claims a method and apparatus for managing dynamic web page generation requests.

In one embodiment, the present invention claims a computer-implemented method for managing a dynamic Web page generation request to a Web server, the computer-implemented method comprising the steps of routing the request from the Web server to a page server, the page server receiving the request and releasing the Web server to process other requests, processing the request, the processing being performed by the page server concurrently with the Web server, as the Web server processes the other requests, and dynamically generating a Web page in response to the request, the Web page including data dynamically retrieved from one or more data sources. Other embodiments also include connection caches to the one or more data sources, page caches for each page server, and custom HTML extension templates for configuring the Web page.

Other objects, features and advantages of the present invention will be apparent from the accompanying drawings and from the detailed description.

**BRIEF DESCRIPTION OF THE DRAWINGS**

FIG. 1 illustrates a typical computer system in which the present invention operates.

FIG. 2 illustrates a typical prior art Web server environment.

FIG. 3 illustrates a typical prior art Web server environment in the form of a flow diagram.

FIG. 4 illustrates one embodiment of the presently claimed invention.

FIG. 5 illustrates the processing of a Web browser request in the form of a flow diagram, according to one embodiment of the presently claimed invention.

**DETAILED DESCRIPTION OF THE  
PREFERRED EMBODIMENT**

The present invention relates to a method and apparatus for creating and managing custom Web sites. In the following detailed description, numerous specific details are set forth in order to provide a thorough understanding of the present invention. It will be apparent to one of ordinary skill in the art, however, that these specific details need not be used to practice the present invention. In other instances, well-known structures, interfaces and processes have not been shown in detail in order not to unnecessarily obscure the present invention.

FIG. 1 illustrates a typical computer system 100 in which the present invention operates. The preferred embodiment of

5,894,554

3

the present invention is implemented on an IBM™ Personal Computer manufactured by IBM Corporation of Armonk, N.Y. An alternate embodiment may be implemented on an RS/6000™ Workstation manufactured by IBM Corporation of Armonk, N.Y. It will be apparent to those of ordinary skill in the art that other computer system architectures may also be employed.

In general, such computer systems as illustrated by FIG 1 comprise a bus 101 for communicating information, a processor 102 coupled with the bus 101 for processing information, main memory 103 coupled with the bus 101 for storing information and instructions for the processor 102, a read-only memory 104 coupled with the bus 101 for storing static information and instructions for the processor 102, a display device 105 coupled with the bus 101 for displaying information for a computer user, an input device 106 coupled with the bus 101 for communicating information and command selections to the processor 102, and a mass storage device 107, such as a magnetic disk and associated disk drive, coupled with the bus 101 for storing information and instructions. A data storage medium 108 containing digital information is configured to operate with mass storage device 107 to allow processor 102 access to the digital information on data storage medium 108 via bus 101.

Processor 102 may be any of a wide variety of general purpose processors or microprocessors such as the Pentium™ microprocessor manufactured by Intel™ Corporation or the RS/6000™ processor manufactured by IBM Corporation. It will be apparent to those of ordinary skill in the art, however, that other varieties of processors may also be used in a particular computer system. Display device 105 may be a liquid crystal device, cathode ray tube (CRT), or other suitable display device. Mass storage device 107 may be a conventional hard disk drive, floppy disk drive, CD-ROM drive, or other magnetic or optical data storage device for reading and writing information stored on a hard disk, a floppy disk, a CD-ROM, a magnetic tape, or other magnetic or optical data storage medium. Data storage medium 108 may be a hard disk, a floppy disk, a CD-ROM, a magnetic tape, or other magnetic or optical data storage medium.

In general, processor 102 retrieves processing instructions and data from a data storage medium 108 using mass storage device 107 and downloads this information into random access memory 103 for execution. Processor 102, then executes an instruction stream from random access memory 103 or read-only memory 104. Command selections and information input at input device 106 are used to direct the flow of instructions executed by processor 102. Equivalent input device 106 may also be a pointing device such as a conventional mouse or trackball device. The results of this processing execution are then displayed on display device 105.

The preferred embodiment of the present invention is implemented as a software module, which may be executed on a computer system such as computer system 100 in a conventional manner. Using well known techniques, the application software of the preferred embodiment is stored on data storage medium 108 and subsequently loaded into and executed within computer system 100. Once initiated, the software of the preferred embodiment operates in the manner described below.

FIG. 2 illustrates a typical prior art Web server environment. Web client 200 can make URL requests to Web server 201 or Web server 202. Web servers 201 and 202 include Web server executables 201(E) and 202(E) respectively,

4

that perform the processing of Web client requests. Each Web server may have a number of Web pages 201(1)-(n) and 202(1)-(n). Depending on the URL specified by the Web client 200, the request may be routed by either Web server executable 201(E) to Web page 201(1), for example, or from Web server executable 202(E) to Web page 202(1). Web client 200 can continue making URL requests to retrieve other Web pages. Web client 200 can also use hyperlinks within each Web page to "jump" to other Web pages or to other locations within the same Web page.

FIG. 3 illustrates this prior art Web server environment in the form of a flow diagram. In processing block 300, the Web client makes a URL request. This URL request is examined by the Web browser to determine the appropriate Web server to route the request to in processing block 302. In processing block 304 the request is then transmitted from the Web browser to the appropriate Web server, and in processing block 306 the Web server executable examines the URL to determine whether it is a HTML document or a CGI application. If the request is for an HTML document 308, then the Web server executable locates the document in processing block 310. The document is then transmitted back through the requesting Web browser for formatting and display in processing block 312.

If the URL request is for a CGI application 314, however, the Web server executable locates the CGI application in processing block 316. The CGI application then executes and outputs HTML output in processing block 318 and finally, the HTML output is transmitted back to requesting Web browser for formatting and display in processing block 320.

This prior art Web server environment does not, however, provide any mechanism for managing the Web requests or the Web sites. As Web sites grow, and as the number of Web clients and requests increase, Web site management becomes a crucial need.

For example, a large Web site may receive thousands of requests or "hits" in a single day. Current Web servers process each of these requests on a single machine, namely the Web server machine. Although these machines may be running "multi-threaded" operating systems that allow transactions to be processed by independent "threads," all the threads are nevertheless on a single machine, sharing a processor. As such, the Web executable thread may hand off a request to a processing thread, but both threads will still have to be handled by the processor on the Web server machine. When numerous requests are being simultaneously processed by multiple threads on a single machine, the Web server can slow down significantly and become highly inefficient. The claimed invention addresses this need by utilizing a partitioned architecture to facilitate the creation and management of custom Web sites and servers.

FIG. 4 illustrates one embodiment of the presently claimed invention. Web client 200 issues a URL request that is processed to determine proper routing. In this embodiment, the request is routed to Web server 201. Instead of Web server executable 201(E) processing the URL request, however, Interceptor 400 intercepts the request and routes it to Dispatcher 402. In one embodiment, Interceptor 400 resides on the Web server machine as an extension to Web server 201. This embodiment is appropriate for Web servers such as Netsite™ from Netscape, that support such extensions. A number of public domain Web servers, such as NCSA™ from the National Center for Supercomputing Applications at the University of Illinois, Urbana-Champaign, however, do not provide support for

5.894.554

5

this type of extension. Thus, in an alternate embodiment, Interceptor 400 is an independent module, connected via an "intermediate program" to Web server 201. This intermediate program can be a simple CGI application program that connects Interceptor 400 to Web server 201. Alternate intermediate programs that perform the same functionality can also be implemented.

In one embodiment of the invention, Dispatcher 402 resides on a different machine than Web server 201. This embodiment overcomes the limitation described above, in prior art Web servers, wherein all processing is performed by the processor on a single machine. By routing the request to Dispatcher 402 residing on a different machine than the Web server executable 201(E), the request can then be processed by a different processor than the Web server executable 201(E). Web server executable 201(E) is thus free to continue servicing client requests on Web server 201 while the request is processed "off-line," at the machine on which Dispatcher 402 resides.

Dispatcher 402 can, however, also reside on the same machine as the Web server. The Web site administrator has the option of configuring Dispatcher 402 on the same machine as Web server 201, taking into account a variety of factors pertinent to a particular Web site, such as the size of the Web site, the number of Web pages and the number of hits at the Web site. Although this embodiment will not enjoy the advantage described above, namely off-loading the processing of Web requests from the Web server machine, the embodiment does allow flexibility for a small Web site to grow. For example, a small Web site administrator can use a single machine for both Dispatcher 402 and Web server 201 initially, then off-load Dispatcher 402 onto a separate machine as the Web site grows. The Web site can thus take advantage of other features of the present invention regardless of whether the site has separate machines configured as Web servers and dispatchers.

Dispatcher 402 receives the intercepted request and then dispatches the request to one of a number of Page servers 404(1)-(n). For example, if Page server 404(1) receives the dispatched request, it processes the request and retrieves the data from an appropriate data source, such as data source 406, data source 408, or data source 410. Data sources, as used in the present application, include databases, spreadsheets, files and any other type of data repository. Page server 404(1) can retrieve data from more than one data source and incorporate the data from these multiple data sources in a single Web page.

In one embodiment, each Page server 404(1)-(n) resides on a separate machine on the network to distribute the processing of the request. Dispatcher 402 maintains a variety of information regarding each Page server on the network, and dispatches requests based on this information. For example, Dispatcher 402 retains dynamic information regarding the data sources that any given Page server can access. Dispatcher 402 thus examines a particular request and determines which Page servers can service the URL request. Dispatcher 402 then hands off the request to the appropriate Page server.

For example, if the URL request requires financial data from data source 408, dispatcher 402 will first examine an information list. Dispatcher 402 may determine that Page server 404(3), for example, has access to the requisite data in data source 408. Dispatcher 402 will thus route the URL request to Page server 404(3). This "connection caching" functionality is described in more detail below, under the heading "Performance."

6

Alternately, Dispatcher 402 also has the ability to determine whether a particular Page server already has the necessary data cached in the Page server's page cache (described in more detail below, under the heading "Performance"). Dispatcher 402 may thus determine that Page server 404(1) and 404(2) are both logged into Data source 408, but that Page server 404(2) has the financial information already cached in Page server 404(2)'s page cache. In this case, Dispatcher 402 will route the URL request to Page server 404(2) to more efficiently process the request.

Finally, Dispatcher 402 may determine that a number or all Page servers 404(1)-(n) are logged into Data source 408. In this scenario, Dispatcher 402 can examine the number of requests that each Page server is servicing and route the request to the least busy page server. This "load balancing" capability can significantly increase performance at a busy Web site and is discussed in more detail below, under the heading "Scalability".

If, for example, Page server 404(2) receives the request, Page server 404(2) will process the request. While Page server 404(2) is processing the request, Web server executable 201(E) can concurrently process other Web client requests. This partitioned architecture thus allows both Page server 404(2) and Web server executable 201(E) to simultaneously process different requests, thus increasing the efficiency of the Web site. Page server 404(2) dynamically generates a Web page in response to the Web client request, and the dynamic Web page is then either transmitted back to requesting Web client 200 or stored on a machine that is accessible to Web server 201, for later retrieval.

One embodiment of the claimed invention also provides a Web page designer with HTML extensions, or "dyna" tags. These dyna tags provide customized HTML functionality to a Web page designer, to allow the designer to build customized HTML templates that specify the source and placement of retrieved data. For example, in one embodiment, a "dynatext" HTML extension tag specifies a data source and a column name to allow the HTML template to identify the data source to log into and the column name from which to retrieve data. Alternatively, "dyna-anchor" tags allow the designer to build hyperlink queries while "dynablock" tags provide the designer with the ability to iterate through blocks of data. Page servers use these HTML templates to create dynamic Web pages. Then, as described above, these dynamic Web pages are either transmitted back to requesting Web client 200 or stored on a machine that is accessible to Web server 201, for later retrieval.

The presently claimed invention provides numerous advantages over prior art Web servers, including advantages in the areas of performance, security, extensibility and scalability.

#### Performance

One embodiment of the claimed invention utilizes connection caching and page caching to improve performance. Each Page server can be configured to maintain a cache of connections to numerous data sources. For example, as illustrated in FIG. 4, Page server 404(1) can retrieve data from data source 406, data source 408 or data source 410. Page server 404(1) can maintain connection cache 412(1) containing connections to each of data source 406, data source 408 and data source 410, thus eliminating connect times from the Page servers to those data sources.

Additionally, another embodiment of the present invention supports the caching of finished Web pages, to optimize

5,894.554

7

the performance of the data source being utilized. This "page caching" feature, illustrated in FIG. 4 as Page cache 414, allows the Web site administrator to optimize the performance of data sources by caching Web pages that are repeatedly accessed. Once the Web page is cached, subsequent requests or "hits" will utilize the cached Web page rather than re-accessing the data source. This can radically improve the performance of the data source.

#### Security

The present invention allows the Web site administrator to utilize multiple levels of security to manage the Web site. In one embodiment, the Page server can utilize all standard encryption and site security features provided by the Web server. In another embodiment, the Page server can be configured to bypass connection caches 412(1)-(n), described above, for a particular data source and to require entry of a user-supplied identification and password for the particular data source the user is trying to access.

Additionally, another embodiment of the presently claimed invention requires no real-time access of data sources. The Web page caching ability, described above, enables additional security for those sites that want to publish non-interactive content from internal information systems, but do not want real-time Internet accessibility to those internal information systems. In this instance, the Page server can act as a "replication and staging agent" and create Web pages in batches, rather than in real-time. These "replicated" Web pages are then "staged" for access at a later time, and access to the Web pages in this scenario is possible even if the Page server and dispatcher are not present later.

In yet another embodiment, the Page server can make a single pass through a Web library, and compile a Web site that exists in the traditional form of separately available files. A Web library is a collection of related Web books and Web pages. More specifically, the Web library is a hierarchical organization of Web document templates, together with all the associated data source information. Information about an entire Web site is thus contained in a single physical file, thus simplifying the problem of deploying Web sites across multiple Page servers. The process of deploying the Web site in this embodiment is essentially a simple copy of a single file.

#### Extensibility

One embodiment of the present invention provides the Web site administrator with Object Linking and Embedding (OLE) 2.0 extensions to extend the page creation process. These OLE 2.0 extensions also allow information submitted over the Web to be processed with user-supplied functionality. Utilizing development tools such as Visual Basic, Visual C++ or PowerBuilder that support the creation of OLE 2.0 automation, the Web site administrator can add features and modify the behavior of the Page servers described above. This extensibility allows one embodiment of the claimed invention to be incorporated with existing technology to develop an infinite number of custom web servers.

For example, OLE 2.0 extensions allow a Web site administrator to encapsulate existing business rules in an OLE 2.0 automation interface, to be accessed over the Web. One example of a business rule is the steps involved in the payoff on an installment or mortgage loan. The payoff may involve, for example, taking into account the current balance, the date and the interest accrued since the last payment. Most organizations already have this type of

8

business rule implemented using various applications, such as Visual Basic for client-server environments, or CICS programs on mainframes. If these applications are OLE 2.0 compliant, the Page server "dynaobject" HTML extension tag can be used to encapsulate the application in an OLE 2.0 automation interface. The Page server is thus extensible, and can incorporate the existing application with the new Page server functionality.

#### Scalability

One embodiment of the claimed invention allows "plug and play" scalability. As described above, referring to FIG. 4, Dispatcher 402 maintains information about all the Page servers configured to be serviced by Dispatcher 402. Any number of Page servers can thus be "plugged" into the configuration illustrated in FIG. 4, and the Page servers will be instantly activated as the information is dynamically updated in Dispatcher 402. The Web site administrator can thus manage the overhead of each Page server and modify each Page server's load, as necessary, to improve performance. In this manner, each Page server will cooperate with other Page servers within a multi-server environment. Dispatcher 402 can examine the load on each Page server and route new requests according to each Page server's available resources. This "load-balancing" across multiple Page servers can significantly increase a Web site's performance.

FIG. 5 illustrates the processing of a Web browser request in the form of a flow diagram, according to one embodiment of the presently claimed invention. A Web browser sends a URL request to a Web server in processing block 500. In processing block 502, the Web server receives the URL request, and an interceptor then intercepts the handling of the request in processing block 504. The interceptor connects to a dispatcher and sends the URL request to the dispatcher in processing block 506. In processing block 508, the dispatcher determines which Page servers can handle the request. The dispatcher also determines which Page server is processing the fewest requests in processing block 510, and in processing block 512, the dispatcher sends the URL request to an appropriate Page server. The Page server receives the request and produces an HTML document in processing block 514. The Page server then responds to the dispatcher with notification of the name of the cached HTML document in processing block 516. In processing block 518, the dispatcher responds to the interceptor with the document name, and the interceptor then replaces the requested URL with the newly generated HTML document in processing block 520. The Web server then sends the new HTML document to the requesting client in processing block 522. Finally, the Web browser receives and displays the HTML document created by the Page server at processing block 524.

Thus, a method and apparatus for creating and managing custom Web sites is disclosed. These specific arrangements and methods described herein are merely illustrative of the principles of the present invention. Numerous modifications in form and detail may be made by those of ordinary skill in the art without departing from the scope of the present invention. Although this invention has been shown in relation to a particular preferred embodiment, it should not be considered so limited. Rather, the present invention is limited only by the scope of the appended claims.

We claim:

1. A computer-implemented method for managing a dynamic Web page generation request to a Web server, said computer-implemented method comprising the steps of:
  - a. routing said request from said Web server to a page server;
  - b. said page server receiving said request and releasing

5,894,554

9

said Web server to process other requests, wherein said routing step further includes the steps of intercepting said request at said Web server, routing said request from said Web server to a dispatcher, and dispatching said request to said page server;

5 processing said request, said processing being performed by said page server while said Web server concurrently processes said other requests; and

dynamically generating a Web page in response to said request, said Web page including data dynamically retrieved from one or more data sources.

10 2. The computer-implemented method in claim 1 wherein said step of processing said request includes the step of identifying said one or more data sources from which to retrieve said data.

15 3. The computer-implemented method in claim 2 wherein said step of dynamically generating said Web page includes the step of dynamically retrieving said data from said one or more data sources.

20 4. The computer-implemented method in claim 3 wherein said step of processing said request includes the step of said page server maintaining a connection cache to said one or more data sources.

25 5. The computer-implemented method in claim 3 wherein said step of processing said request includes the step of logging into said one or more data sources.

30 6. The computer-implemented method in claim 3 wherein said step of dynamically generating said Web page includes the step of maintaining a page cache containing said Web page.

35 7. The computer-implemented method in claim 3 wherein said page server includes custom HTML extension templates for configuring said Web page.

40 8. The computer-implemented method in claim 7 wherein said step of processing said request further includes the step of inserting said dynamically retrieved data from said one or more data sources into said custom HTML extension templates.

9. A networked system for managing a dynamic Web page generation request, said system comprising:

one or more data sources;

a page server having a processing means;

10

a first computer system including means for generating said request; and

a second computer system including means for receiving said request from said first computer, said second computer system also including a router, said router routing said request from said second computer system to said page server, wherein said routing further includes intercepting said request at said second computer, routing said request from said second computer to a dispatcher, and dispatching said request to said page server said page server receiving said request and releasing said second computer system to process other requests, said page server processing means processing said request and dynamically generating a Web page in response to said request, said Web page including data dynamically retrieved from said one or more data sources.

10. The networked system in claim 9 wherein said router in said second computer system includes:

an interceptor intercepting said request at said second computer system and routing said request; and

a dispatcher receiving said routed request from said interceptor and dispatching said request to said page server.

11. A machine readable medium having stored thereon data representing sequences of instructions, which when executed by a computer system, cause said computer system to perform the steps of:

routing a dynamic Web page generation request from a Web server to a page server, said page server receiving said request and releasing said Web server to process other requests wherein said routing step further includes the steps of intercepting said request at said Web server, routing said request from said Web server to a dispatcher, and dispatching said request to said page server;

processing said request, said processing being performed by said page server while said Web server concurrently processes said other requests; and

dynamically generating a Web page, said Web page including data retrieved from one or more data sources

\* \* \* \* \*



(12) **United States Patent**  
**Lowery et al.**

(10) **Patent No.:** US 6,415,335 B1  
 (45) **Date of Patent:** \*Jul. 2, 2002

(54) **SYSTEM AND METHOD FOR MANAGING DYNAMIC WEB PAGE GENERATION REQUESTS**

5,752,246 A \* 5/1998 Rogers et al. 707/10  
 5,754,772 A \* 5/1998 Leaf 395/200.33  
 5,761,673 A \* 6/1998 Bookman et al. 707/104  
 5,774,660 A 6/1998 Brendel et al. 395/200.31  
 5,774,668 A 6/1998 Choquier et al. 395/200.53

(75) **Inventors:** Kelth Lowery, Richardson; Andrew B. Levine, Plano; Ronald L. Howell. Rowlett, all of TX (US)

**OTHER PUBLICATIONS**

(73) **Assignee:** epicRealm Operating Inc., Richardson, TX (US)

Hoffner. 'Inter-operability and distributed application platform design', Web URL: http://www.ansa.co.uk/, 1995, pp. 342-356 \*

(\* ) **Notice:** Subject to any disclaimer, the term of this patent is extended or adjusted under 35 U.S.C. 154(b) by 0 days

Mourad et al, 'Scalable Web Server Architectures'. IEEE. Jun. 1997, pp. 12-16 \*

This patent is subject to a terminal disclaimer.

Dias et al, 'A Scalable and Highly Available Web Server'. IEEE, 1996, pp. 85-92 \*

(21) **Appl No:** 09/234,048

'Single System Image and Load Balancing for Network Access to a Loosely Coupled Complex', IBM TDB, vol. 34. Feb. 1992, pp. 464-467 \*

(22) **Filed:** Jan. 19, 1999

Dias, Daniel M., et al.; A Scalable and Highly Available Web Server; IBM Research Division; T.J. Watson Research Center; 7 pages.

**Related U.S. Application Data**

(List continued on next page)

(62) **Division of application No** 08/636,477, filed on Apr. 23, 1996, now Pat. No. 5,894,554

*Primary Examiner*—Jeffrey Gaffin  
*Assistant Examiner*—Rehana Perveen

(51) **Int. Cl.** G06F 13/14; G06F 13/20  
 (52) **U.S. Cl.** 710/5; 710/7; 709/219; 709/223; 709/238

(74) *Attorney, Agent, or Firm*—Baker Botts L.L.P.

(58) **Field of Search** 709/238, 223, 709/219; 710/5, 7, 20-21

(57) **ABSTRACT**

(56) **References Cited**

The present invention teaches a method and apparatus for creating and managing custom Web sites. Specifically, one embodiment of the present invention claims a computer-implemented method for managing a dynamic Web page generation request to a Web server, the computer-implemented method comprising the steps of routing the request from the Web server to a page server, the page server receiving the request and releasing the Web server to process other requests, processing the request, the processing being performed by the page server concurrently with the Web server, as the Web server processes the other requests, and dynamically generating a Web page in response to the request, the Web page including data dynamically retrieved from one or more data sources

**U S PATENT DOCUMENTS**

4,866,706 A 9/1989 Christophersen et al. 370/85.7  
 5,341,499 A 8/1994 Doragh 395/700  
 5,392,400 A 2/1995 Berkowitz et al. 395/200  
 5,404,522 A 4/1995 Carmon et al. 395/650  
 5,404,523 A 4/1995 DellaFera et al. 395/650  
 5,404,527 A \* 4/1995 Irwin et al. 395/700  
 5,452,460 A 9/1995 Distelberg et al. 395/700  
 5,532,838 A 7/1996 Barbari 358/400  
 5,701,463 A \* 12/1997 Malcolm 395/610  
 5,751,956 A 5/1998 Kirsch 395/200.33

29 Claims, 4 Drawing Sheets

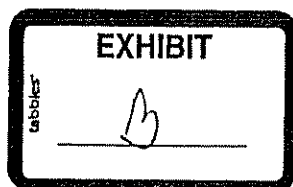
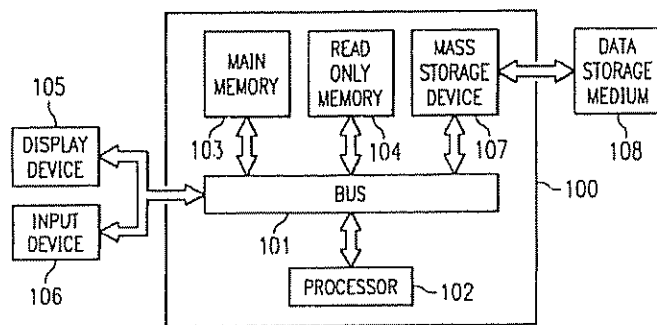

US 6,415,335 B1

Page 2

---

OTHER PUBLICATIONS

Andresen, Daniel, Et Al ; Scalability Issues for High Performance Digital Libraries on the World Wide Web; Department of Computer Science; University of California at Santa Barbara; 10 pages

Andresen, Daniel, Et Al ; SWEB: Towards a Scalable World Wide Web Server on Multicomputers; Department of Computer Science; University of California at Santa Barbara; 7 pages

Holmedahl, Vegard; Et Al; Cooperative Caching of Dynamic Content on a Distributed Web Server; Department of Computer Science; University of California at Santa Barbara; 8 pages.

Overson, Nicole; NeXT Ships WebObjects—On Time—As Promised; Deja.com: NeXT Ships WebObjects—On Time—As Promishttp://X28.deja.com/-doc/ST\_\_m=ps .EXT=927585438.1744765032&hitnum=33

International Search Report; 7 pages; dated Aug. 21, 1997

Birman, Kenneth P. and van Renesse, Robbert; Software for Reliable Networks; Scientific American; May 1996; pp 64-69.

"Beyond the Web: Excavating the Real World Via Mosaic"; Goldberg et al ; Second International WWW Conference; Oct 17, 1994

\* cited by examiner

FIG. 1

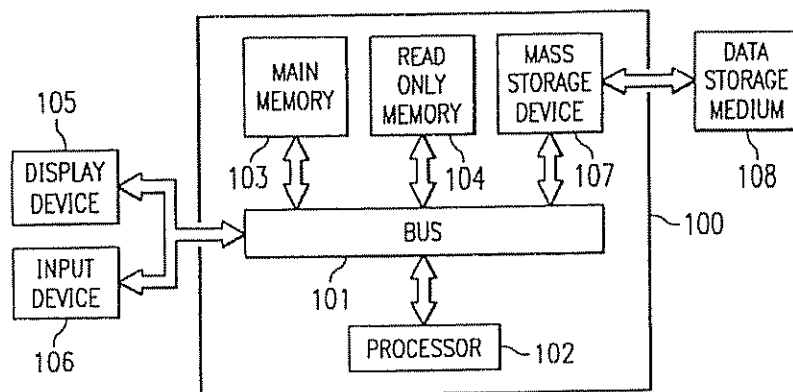

FIG. 2  
(PRIOR ART)

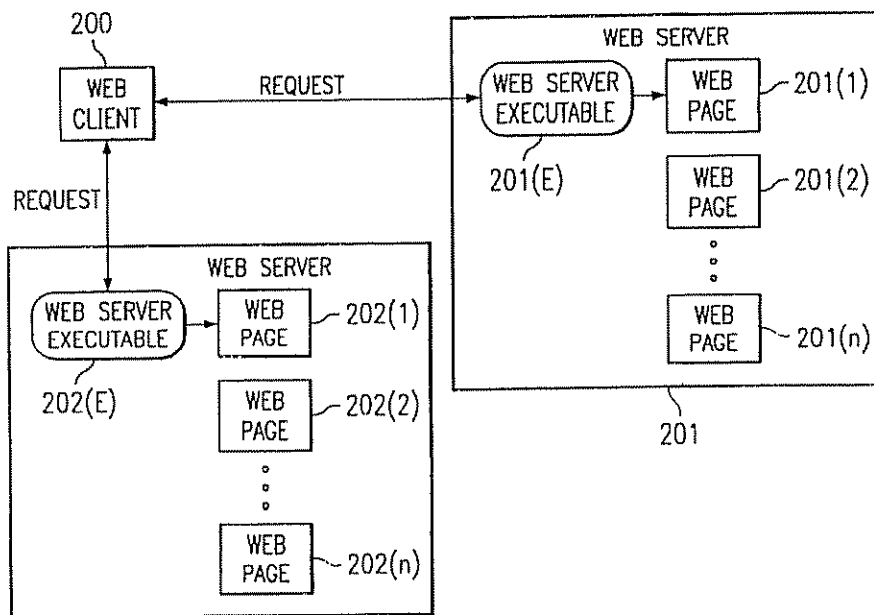
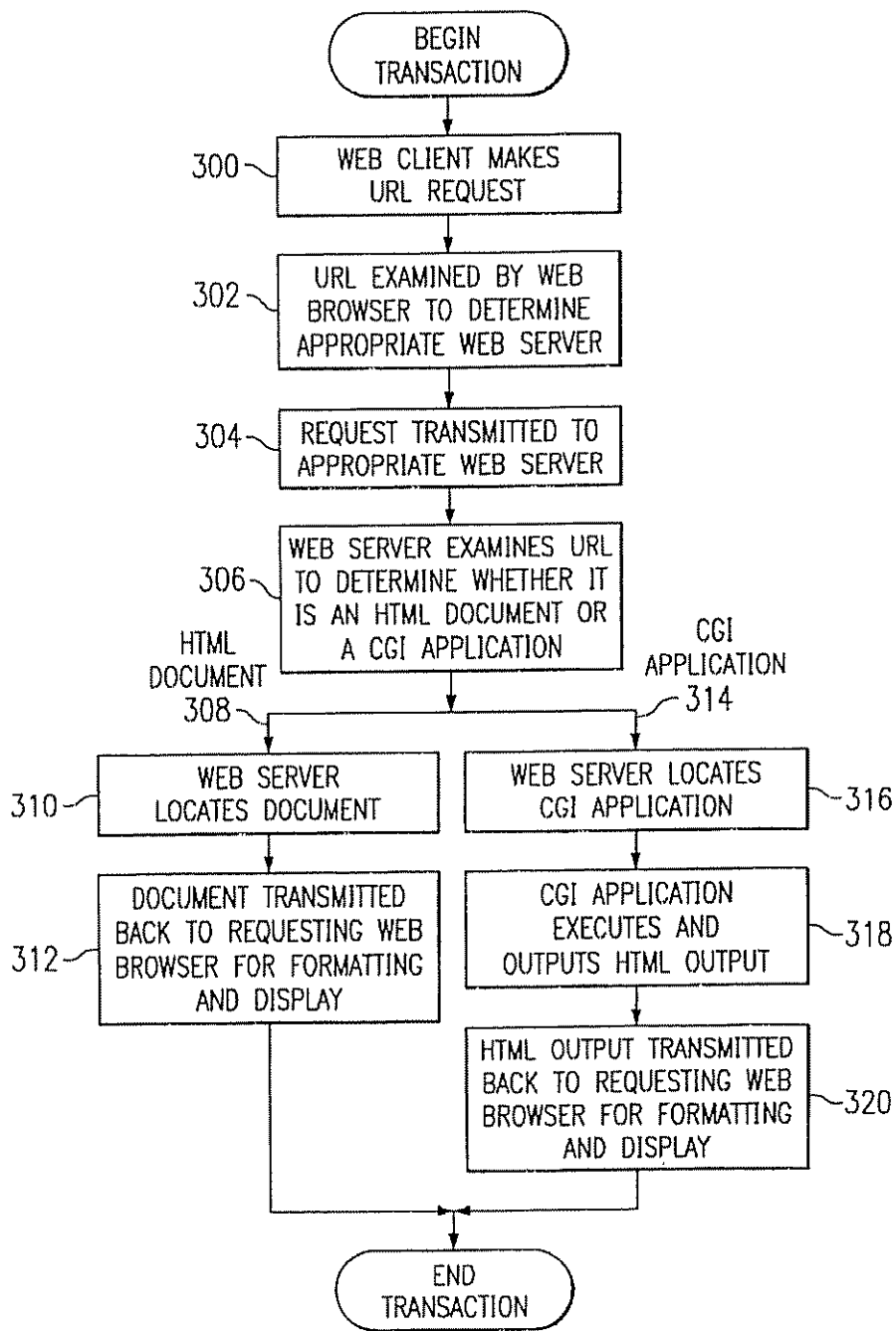
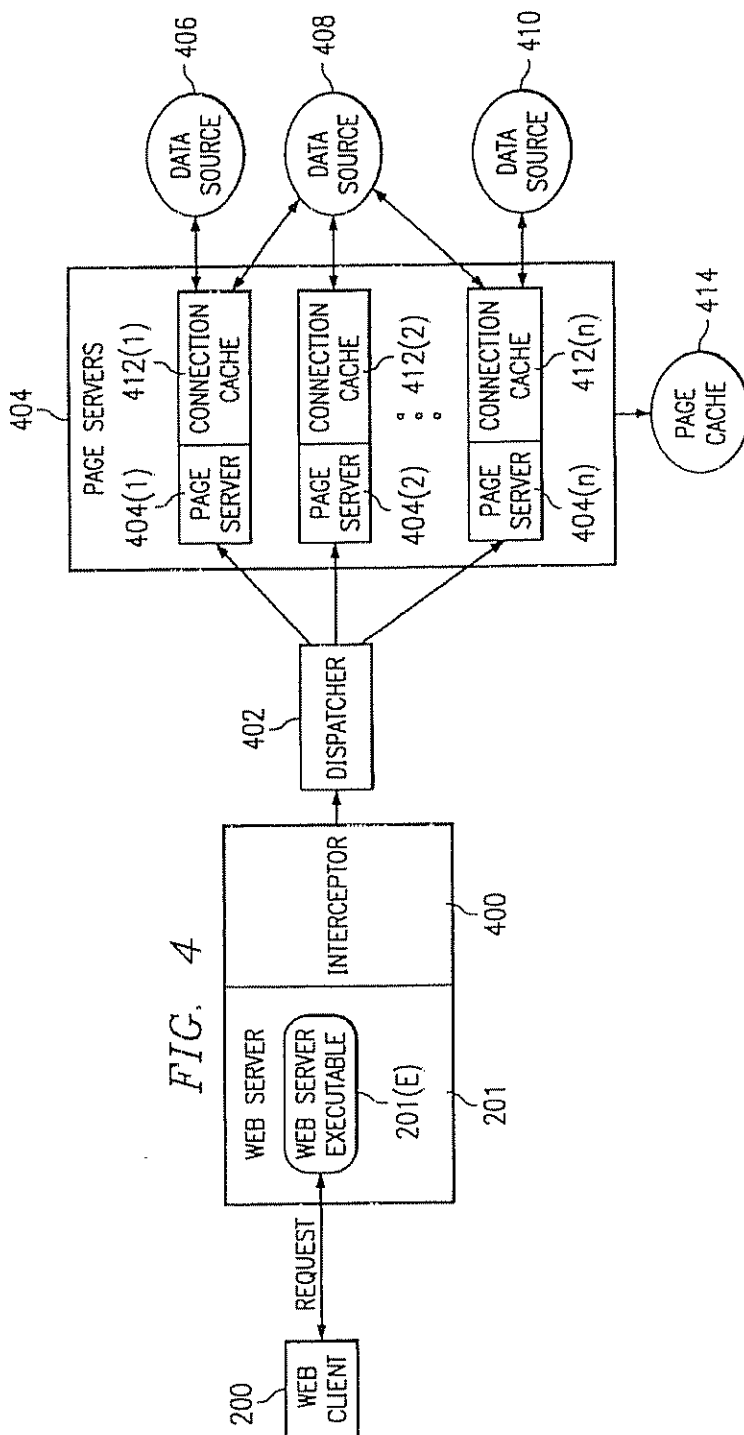



FIG. 3  
(PRIOR ART)





U.S. Patent

Jul. 2, 2002

Sheet 4 of 4

US 6,415,335 B1

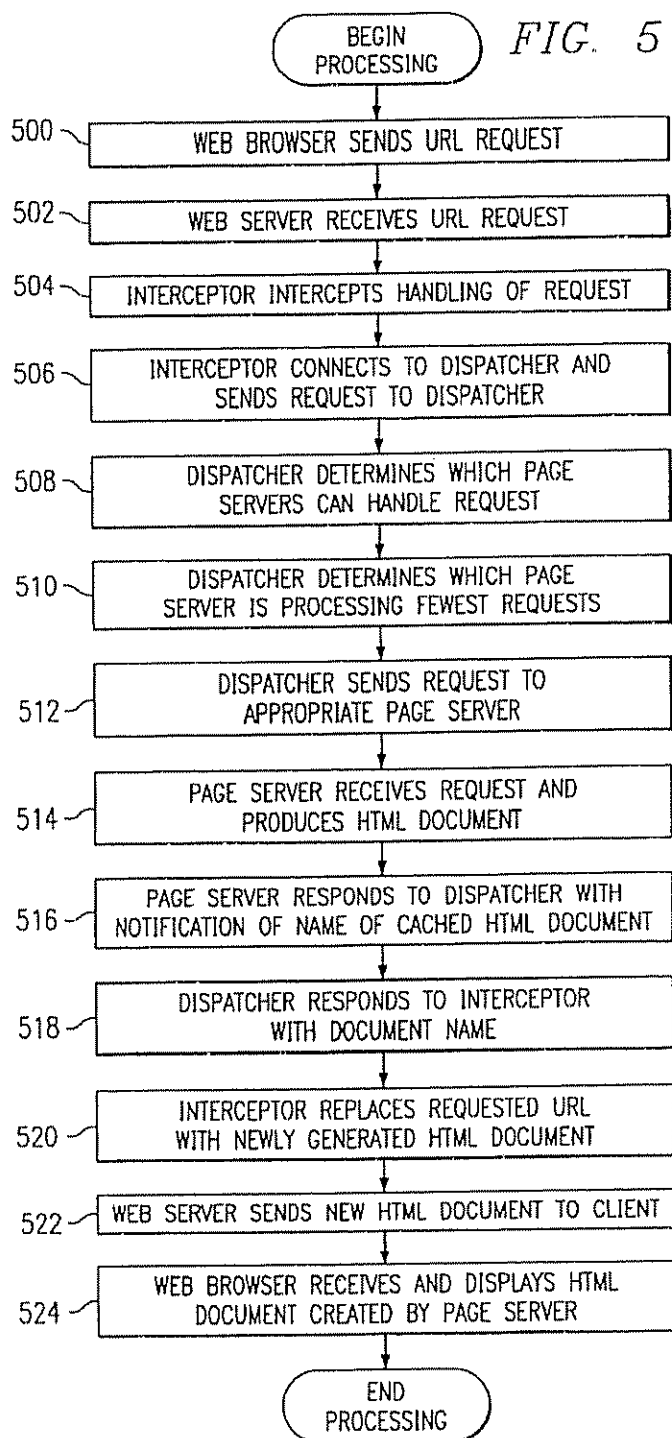

US 6,415,335 B1

1

## SYSTEM AND METHOD FOR MANAGING DYNAMIC WEB PAGE GENERATION REQUESTS

This application is a division of Ser. No. 08/636,477, filed Apr. 23, 1996, now U.S. Pat. No. 5,894,554.

### FIELD OF THE INVENTION

The present invention relates to the field of Internet technology. Specifically, the present invention relates to the creation and management of custom World Wide Web sites.

### DESCRIPTION OF RELATED ART

The World Wide Web (the Web) represents all of the computers on the Internet that offer users access to information on the Internet via interactive documents or Web pages. These Web pages contain hypertext links that are used to connect any combination of graphics, audio, video and text, in a non-linear, non-sequential manner. Hypertext links are created using a special software language known as HyperText Mark-Up Language (HTML).

Once created, Web pages reside on the Web, on Web servers or Web sites. A Web site can contain numerous Web pages. Web client machines running Web browsers can access these Web pages at Web sites via a communications protocol known as HyperText Transport Protocol (HTTP). Web browsers are software interfaces that run on World Wide Web clients to allow access to Web sites via a simple user interface. A Web browser allows a Web client to request a particular Web page from a Web site by specifying a Uniform Resource Locator (URL). A URL is a Web address that identifies the Web page and its location on the Web. When the appropriate Web site receives the URL, the Web page corresponding to the requested URL is located, and if required, HTML output is generated. The HTML output is then sent via HTTP to the client for formatting on the client's screen.

Although Web pages and Web sites are extremely simple to create, the proliferation of Web sites on the Internet highlighted a number of problems. The scope and ability of a Web page designer to change the content of the Web page was limited by the static nature of Web pages. Once created, a Web page remained static until it was manually modified. This in turn limited the ability of Web site managers to effectively manage their Web sites.

The Common Gateway Interface (CGI) standard was developed to resolve the problem of allowing dynamic content to be included in Web pages. CGI "calls" or procedures enable applications to generate dynamically created HTML output, thus creating Web pages with dynamic content. Once created, these CGI applications do not have to be modified in order to retrieve "new" or dynamic data. Instead, when the Web page is invoked, CGI "calls" or procedures are used to dynamically retrieve the necessary data and to generate a Web page.

CGI applications also enhanced the ability of Web site administrators to manage Web sites. Administrators no longer have to constantly update static Web pages. A number of vendors have developed tools for CGI based development, to address the issue of dynamic Web page generation. Companies like Spider™ and Bluestone™, for example, have each created development tools for CGI-based Web page development. Another company, Haht Software™, has developed a Web page generation tool that uses a BASIC-like scripting language, instead of a CGI scripting language.

2

Tools that generate CGI applications do not, however, resolve the problem of managing numerous Web pages and requests at a Web site. For example, a single company may maintain hundreds of Web pages at their Web site. Current Web server architecture also does not allow the Web server to efficiently manage the Web page and process Web client requests. Managing these hundreds of Web pages in a coherent manner and processing all requests for access to the Web pages is thus a difficult task. Existing development tools are limited in their capabilities to facilitate dynamic Web page generation, and do not address the issue of managing Web requests or Web sites.

### SUMMARY OF THE INVENTION

It is therefore an object of the present invention to provide a method and apparatus for creating and managing custom Web sites. Specifically, the present invention claims a method and apparatus for managing dynamic web page generation requests.

In one embodiment, the present invention claims a computer-implemented method for managing a dynamic Web page generation request to a Web server, the computer-implemented method comprising the steps of routing the request from the Web server to a page server, the page server receiving the request and releasing the Web server to process other requests, processing the request, the processing being performed by the page server concurrently with the Web server, as the Web server processes the other requests, and dynamically generating a Web page in response to the request, the Web page including data dynamically retrieved from one or more data sources. Other embodiments also include connection caches to the one or more data sources, page caches for each page server, and custom HTML extension templates for configuring the Web page.

Other objects, features and advantages of the present invention will be apparent from the accompanying drawings and from the detailed description.

### BRIEF DESCRIPTION OF THE DRAWINGS

FIG. 1 illustrates a typical computer system in which the present invention operates.

FIG. 2 illustrates a typical prior art Web server environment.

FIG. 3 illustrates a typical prior art Web server environment in the form of a flow diagram.

FIG. 4 illustrates one embodiment of the presently claimed invention.

FIG. 5 illustrates the processing of a Web browser request in the form of a flow diagram, according to one embodiment of the presently claimed invention.

### DETAILED DESCRIPTION OF THE PREFERRED EMBODIMENT

The present invention relates to a method and apparatus for creating and managing custom Web sites. In the following detailed description, numerous specific details are set forth in order to provide a thorough understanding of the present invention. It will be apparent to one of ordinary skill in the art, however, that these specific details need not be used to practice the present invention. In other instances, well-known structures, interfaces and processes have not been shown in detail in order not to unnecessarily obscure the present invention.

FIG. 1 illustrates a typical computer system 100 in which the present invention operates. The preferred embodiment of

US 6,415,335 B1

3

the present invention is implemented on an IBM™ Personal Computer manufactured by IBM Corporation of Armonk, New York. An alternate embodiment may be implemented on an RS/6000™ Workstation manufactured by IBM Corporation of Armonk, New York. It will be apparent to those of ordinary skill in the art that other computer system architectures may also be employed.

In general, such computer systems as illustrated by FIG 1 comprise a bus 101 for communicating information, a processor 102 coupled with the bus 101 for processing information, main memory 103 coupled with the bus 101 for storing information and instructions for the processor 102, a read-only memory 104 coupled with the bus 101 for storing static information and instructions for the processor 102, a display device 105 coupled with the bus 101 for displaying information for a computer user, an input device 106 coupled with the bus 101 for communicating information and command selections to the processor 102, and a mass storage device 107, such as a magnetic disk and associated disk drive, coupled with the bus 101 for storing information and instructions. A data storage medium 108 containing digital information is configured to operate with mass storage device 107 to allow processor 102 access to the digital information on data storage medium 108 via bus 101.

Processor 102 may be any of a wide variety of general purpose processors or microprocessors such as the Pentium™ microprocessor manufactured by Intel™ Corporation or the RS/6000™ processor manufactured by IBM Corporation. It will be apparent to those of ordinary skill in the art, however, that other varieties of processors may also be used in a particular computer system. Display device 105 may be a liquid crystal device, cathode ray tube (CRT), or other suitable display device. Mass storage device 107 may be a conventional hard disk drive, floppy disk drive, CD-ROM drive, or other magnetic or optical data storage device for reading and writing information stored on a hard disk, a floppy disk, a CD-ROM, a magnetic tape, or other magnetic or optical data storage medium. Data storage medium 108 may be a hard disk, a floppy disk, a CD-ROM, a magnetic tape, or other magnetic or optical data storage medium.

In general, processor 102 retrieves processing instructions and data from a data storage medium 108 using mass storage device 107 and downloads this information into random access memory 103 for execution. Processor 102, then executes an instruction stream from random access memory 103 or read-only memory 104. Command selections and information input at input device 106 are used to direct the flow of instructions executed by processor 102. Equivalent input device 106 may also be a pointing device such as a conventional mouse or trackball device. The results of this processing execution are then displayed on display device 105.

The preferred embodiment of the present invention is implemented as a software module, which may be executed on a computer system such as computer system 100 in a conventional manner. Using well known techniques, the application software of the preferred embodiment is stored on data storage medium 108 and subsequently loaded into and executed within computer system 100. Once initiated, the software of the preferred embodiment operates in the manner described below.

FIG. 2 illustrates a typical prior art Web server environment. Web client 200 can make URL requests to Web server 201 or Web server 202. Web servers 201 and 202 include Web server executables, 201(E) and 202(E) respectively,

4

that perform the processing of Web client requests. Each Web server may have a number of Web pages 201(1)-(n) and 202(1)-(n). Depending on the URL specified by the Web client 200, the request may be routed by either Web server executable 201(E) to Web page 201(1), for example, or from Web server executable 202(E) to Web page 202(1). Web client 200 can continue making URL requests to retrieve other Web pages. Web client 200 can also use hyperlinks within each Web page to "jump" to other Web pages or to other locations within the same Web page.

FIG 3 illustrates this prior art Web server environment in the form of a flow diagram. In processing block 300, the Web client makes a URL request. This URL request is examined by the Web browser to determine the appropriate Web server to route the request to in processing block 302. In processing block 304 the request is then transmitted from the Web browser to the appropriate Web server, and in processing block 306 the Web server executable examines the URL to determine whether it is a HTML document or a CGI application. If the request is for an HTML document 308, then the Web server executable locates the document in processing block 310. The document is then transmitted back through the requesting Web browser for formatting and display in processing block 312.

If the URL request is for a CGI application 314, however, the Web server executable locates the CGI application in processing block 316. The CGI application then executes and outputs HTML output in processing block 318 and finally, the HTML output is transmitted back to requesting Web browser for formatting and display in processing block 320.

This prior art Web server environment does not, however, provide any mechanism for managing the Web requests or the Web sites. As Web sites grow, and as the number of Web clients and requests increase, Web site management becomes a crucial need.

For example, a large Web site may receive thousands of requests or "hits" in a single day. Current Web servers process each of these requests on a single machine, namely the Web server machine. Although these machines may be running "multi-threaded" operating systems that allow transactions to be processed by independent "threads," all the threads are nevertheless on a single machine, sharing a processor. As such, the Web executable thread may hand off a request to a processing thread, but both threads will still have to be handled by the processor on the Web server machine. When numerous requests are being simultaneously processed by multiple threads on a single machine, the Web server can slow down significantly and become highly inefficient. The claimed invention addresses this need by utilizing a partitioned architecture to facilitate the creation and management of custom Web sites and servers.

FIG 4 illustrates one embodiment of the presently claimed invention. Web client 200 issues a URL request that is processed to determine proper routing. In this embodiment, the request is routed to Web server 201. Instead of Web server executable 201(E) processing the URL request, however, Interceptor 400 intercepts the request and routes it to Dispatcher 402. In one embodiment, Interceptor 400 resides on the Web server machine as an extension to Web server 201. This embodiment is appropriate for Web servers such as Netsite™ from Netscape, that support such extensions. A number of public domain Web servers, such as NCSA™ from the National Center for Supercomputing Applications at the University of Illinois, Urbana-Champaign, however, do not provide support for

US 6,415,335 B1

5

this type of extension. Thus, in an alternate embodiment, Interceptor 400 is an independent module, connected via an "intermediate program" to Web server 201. This intermediate program can be a simple CGI application program that connects Interceptor 400 to Web server 201. Alternate intermediate programs the perform the same functionality can also be implemented.

In one embodiment of the invention, Dispatcher 402 resides on a different machine than Web server 201. This embodiment overcomes the limitation described above, in prior art Web servers, wherein all processing is performed by the processor on a single machine. By routing the request to Dispatcher 402 residing on a different machine than the Web server executable 201(E), the request can then be processed by a different processor than the Web server executable 201(E). Web server executable 201(E) is thus free to continue servicing client requests on Web server 201 while the request is processed "off-line." at the machine on which Dispatcher 402 resides.

Dispatcher 402 can, however, also reside on the same machine as the Web server. The Web site administrator has the option of configuring Dispatcher 402 on the same machine as Web server 201, taking into account a variety of factors pertinent to a particular Web site, such as the size of the Web site, the number of Web pages and the number of bits at the Web site. Although this embodiment will not enjoy the advantage described above, namely off-loading the processing of Web requests from the Web server machine, the embodiment does allow flexibility for a small Web site to grow. For example, a small Web site administrator can use a single machine for both Dispatcher 402 and Web server 201 initially, then off-load Dispatcher 402 onto a separate machine as the Web site grows. The Web site can thus take advantage of other features of the present invention regardless of whether the site has separate machines configured as Web servers and dispatchers.

Dispatcher 402 receives the intercepted request and then dispatches the request to one of a number of Page servers 404(1)-(n). For example, if Page server 404(1) receives the dispatched request, it processes the request and retrieves the data from an appropriate data source, such as data source 406, data source 408, or data source 410. Data sources, as used in the present application, include databases, spreadsheets, files and any other type of data repository. Page server 404(1) can retrieve data from more than one data source and incorporate the data from these multiple data sources in a single Web page.

In one embodiment, each Page server 404(1)-(n) resides on a separate machine on the network to distribute the processing of the request. Dispatcher 402 maintains a variety of information regarding each Page server on the network, and dispatches requests based on this information. For example, Dispatcher 402 retains dynamic information regarding the data sources that any given Page server can access. Dispatcher 402 thus examines a particular request and determines which Page servers can service the URL request. Dispatcher 402 then hands off the request to the appropriate Page server.

For example, if the URL request requires financial data from data source 408, dispatcher 402 will first examine an information list. Dispatcher 402 may determine that Page server 404(3), for example, has access to the requisite data in data source 408. Dispatcher 402 will thus route the URL request to Page server 404(3). This "connection caching" functionality is described in more detail below, under the heading "Performance." Alternately, Dispatcher 402 also

6

has the ability to determine whether a particular Page server already has the necessary data cached in the Page server's page cache (described in more detail below, under the heading "Performance"). Dispatcher 402 may thus determine that Page server 404(1) and 404(2) are both logged into Data source 408, but that Page server 404(2) has the financial information already cached in Page server 404(2)'s page cache. In this case, Dispatcher 402 will route the URL request to Page server 404(2) to more efficiently process the request.

Finally, Dispatcher 402 may determine that a number of all Page servers 404(1)-(n) are logged into Data source 408. In this scenario, Dispatcher 402 can examine the number of requests that each Page server is servicing and route the request to the least busy page server. This "load balancing" capability can significantly increase performance at a busy Web site and is discussed in more detail below, under the heading "Scalability."

If, for example, Page server 404(2), receives the request, Page server 404(2) will process the request. While Page server 404(2) is processing the request, Web server executable 201(E) can concurrently process other Web client requests. This partitioned architecture thus allows both Page server 404(2) and Web server executable 201(E) to simultaneously process different requests, thus increasing the efficiency of the Web site. Page server 404(2) dynamically generates a Web page in response to the Web client request, and the dynamic Web page is then either transmitted back to requesting Web client 200 or stored on a machine that is accessible to Web server 201, for later retrieval.

One embodiment of the claimed invention also provides a Web page designer with HTML extensions, or "dyna" tags. These dyna tags provide customized HTML functionality to a Web page designer, to allow the designer to build customized HTML templates that specify the source and placement of retrieved data. For example, in one embodiment, a "dynatext" HTML extension tag specifies a data source and a column name to allow the HTML template to identify the data source to log into and the column name from which to retrieve data. Alternatively, "dyna-anchor" tags allow the designer to build hyperlink queries while "dynablock" tags provide the designer with the ability to iterate through blocks of data. Page servers use these HTML templates to create dynamic Web pages. Then, as described above, these dynamic Web pages are either transmitted back to requesting Web client 200 or stored on a machine that is accessible to Web server 201, for later retrieval.

The presently claimed invention provides numerous advantages over prior art Web servers, including advantages in the areas of performance, security, extensibility and scalability.

#### Performance

One embodiment of the claimed invention utilizes connection caching and page caching to improve performance. Each Page server can be configured to maintain a cache of connections to numerous data sources. For example, as illustrated in FIG 4, Page server 404(1) can retrieve data from data source 406, data source 408 or data source 410. Page server 404(1) can maintain connection cache 412(1), containing connections to each of data source 406, data source 408 and data source 410, thus eliminating connect times from the Page servers to those data sources.

Additionally, another embodiment of the present invention supports the caching of finished Web pages, to optimize the performance of the data source being utilized. This "page

US 6,415,335 B1

7

caching" feature, illustrated in FIG. 4 as Page cache 414, allows the Web site administrator to optimize the performance of data sources by caching Web pages that are repeatedly accessed. Once the Web page is cached, subsequent requests or "hits" will utilize the cached Web page rather than re-accessing the data source. This can radically improve the performance of the data source.

#### Security

The present invention allows the Web site administrator to utilize multiple levels of security to manage the Web site. In one embodiment, the Page server can utilize all standard encryption and site security features provided by the Web server. In another embodiment, the Page server can be configured to bypass connection caches 412(1)-(n), described above, for a particular data source and to require entry of a user-supplied identification and password for the particular data source the user is trying to access.

Additionally, another embodiment of the presently claimed invention requires no real-time access of data sources. The Web page caching ability, described above, enables additional security for those sites that want to publish non-interactive content from internal information systems, but do not want real-time Internet accessibility to those internal information systems. In this instance, the Page server can act as a "replication and staging agent" and create Web pages in batches, rather than in real-time. These "replicated" Web pages are then "staged" for access at a later time, and access to the Web pages in this scenario is possible even if the Page server and dispatcher are not present later.

In yet another embodiment, the Page server can make a single pass through a Web library, and compile a Web site that exists in the traditional form of separately available files. A Web library is a collection of related Web books and Web pages. More specifically, the Web library is a hierarchical organization of Web document templates, together with all the associated data source information. Information about an entire Web site is thus contained in a single physical file, thus simplifying the problem of deploying Web sites across multiple Page servers. The process of deploying the Web site in this embodiment is essentially a simple copy of a single file.

#### Extensibility

One embodiment of the present invention provides the Web site administrator with Object Linking and Embedding (OLE) 2.0 extensions to extend the page creation process. These OLE 2.0 extensions also allow information submitted over the Web to be processed with user-supplied functionality. Utilizing development tools such as Visual Basic, Visual C++ or PowerBuilder that support the creation of OLE 2.0 automation, the Web site administrator can add features and modify the behavior of the Page servers described above. This extensibility allows one embodiment of the claimed invention to be incorporated with existing technology to develop an infinite number of custom web servers.

For example, OLE 2.0 extensions allow a Web site administrator to encapsulate existing business rules in an OLE 2.0 automation interface, to be accessed over the Web. One example of a business rule is the steps involved in the payoff on an installment or mortgage loan. The payoff may involve, for example, taking into account the current balance, the date and the interest accrued since the last payment. Most organizations already have this type of business rule implemented using various applications, such

8

as Visual Basic for client-server environments, or CICS programs on mainframes. If these applications are OLE 2.0 compliant, the Page server "dynaobject" HTML extension tag can be used to encapsulate the application in an OLE 2.0 automation interface. The Page server is thus extensible, and can incorporate the existing application with the new Page server functionality.

#### Scalability

One embodiment of the claimed invention allows "plug and play" scalability. As described above, referring to FIG. 4, Dispatcher 402 maintains information about all the Page servers configured to be serviced by Dispatcher 402. Any number of Page servers can thus be "plugged" into the configuration illustrated in FIG. 4, and the Page servers will be instantly activated as the information is dynamically updated in Dispatcher 402. The Web site administrator can thus manage the overhead of each Page server and modify each Page server's load, as necessary, to improve performance. In this manner, each Page server will cooperate with other Page servers within a multi-server environment. Dispatcher 402 can examine the load on each Page server and route new requests according to each Page server's available resources. This "load-balancing" across multiple Page servers can significantly increase a Web site's performance.

FIG. 5 illustrates the processing of a Web browser request in the form of a flow diagram, according to one embodiment of the presently claimed invention. A Web browser sends a URI request to a Web server in processing block 500. In processing block 502, the Web server receives the URL request, and an interceptor then intercepts the handling of the request in processing block 504. The interceptor connects to a dispatcher and sends the URL request to the dispatcher in processing block 506. In processing block 508, the dispatcher determines which Page servers can handle the request. The dispatcher also determines which Page server is processing the fewest requests in processing block 510, and in processing block 512, the dispatcher sends the URL request to an appropriate Page server. The Page server receives the request and produces an HTML document in processing block 514. The Page server then responds to the dispatcher with notification of the name of the cached HTML document in processing block 516. In processing block 518, the dispatcher responds to the interceptor with the document name, and the interceptor then replaces the requested URL with the newly generated HTML document in processing block 520. The Web server then sends the new HTML document to the requesting client in processing block 522. Finally, the Web browser receives and displays the HTML document created by the Page server at processing block 524.

Thus, a method and apparatus for creating and managing custom Web sites is disclosed. These specific arrangements and methods described herein are merely illustrative of the principles of the present invention. Numerous modifications in form and detail may be made by those of ordinary skill in the art without departing from the scope of the present invention. Although this invention has been shown in relation to a particular preferred embodiment, it should not be considered so limited. Rather, the present invention is limited only by the scope of the appended claims.

We claim:

1. A computer-implemented method for managing a dynamic Web page generation request to a Web server, said computer-implemented method comprising the steps of:  
 routing a request from a Web server to a page server, said page server receiving said request and releasing said

US 6,415,335 B1

9

Web server to process other requests wherein said routing step further includes the steps of: intercepting said request at said Web server and routing said request to said page server; processing said request, said processing being performed by said page server while said Web server concurrently processes said other requests; and dynamically generating a Web page in response to said request, said Web page including data dynamically retrieved from one or more data sources

2 The computer-implemented method in claim 1 wherein said step of routing said request includes the steps of: routing said request from said Web server to a dispatcher; and dispatching said request to said page server.

3 The computer-implemented method in claim 1 wherein said step of processing said request includes the step of identifying said one or more data sources from which to retrieve said data

4 The computer-implemented method in claim 1 wherein said step of dynamically generating said Web page includes the step of dynamically retrieving said data from said one or more data sources

5 The computer-implemented method in claim 1 wherein said step of processing said request includes the step of said page server maintaining a connection cache to said one or more data sources

6 The computer-implemented method in claim 1 wherein said step of processing said request includes the step of logging into said one or more data sources

7 The computer-implemented method in claim 1 wherein said step of dynamically generating said Web page includes the step of maintaining a page cache containing said Web page.

8 The computer-implemented method in claim 1 wherein said page server includes tag-based text templates for configuring said Web page.

9 The computer-implemented method in claim 8 wherein said step of processing said request further includes the step of inserting said-dynamically retrieved data from said one or more data sources into said tag-based text templates

10 The computer-implemented method in claim 8 wherein at least one of said tag-based text templates drives a format of the data dynamically retrieved from said one or more data sources in response to said request.

11 The computer-implemented method in claim 8 wherein said tag-based text templates include HTML templates

12 The computer-implemented method in claim 1 wherein said step of processing said request further includes the step of dynamically updating data at said one or more data sources

13 The computer-implemented method in claim 1 wherein said step of processing said request further includes the step of processing an object handling extension

14 The computer-implemented method in claim 13 wherein said object handling extension is an OLE extension.

15 A computer-implemented method comprising the steps of: transferring a request from an HTTP-compliant device to a page server, said page server receiving said request and releasing said HTTP-compliant device to process other requests wherein said transferring step further includes the steps of:

10

intercepting said request at said HTTP-compliant device and transferring said request to said page server;

processing said request, said processing being performed by said page server while said HTTP-compliant device concurrently processes said other requests; and

dynamically generating a page in response to said request, said page including data dynamically retrieved from one or more data sources.

16 The computer-implemented method in claim 15 wherein said step of transferring said request includes the steps of: transferring said request from said HTTP-compliant device to a dispatcher; and dispatching said request to said page server.

17 The computer-implemented method in claim 15 wherein said step of processing said request includes the step of identifying said one or more data sources from which to retrieve said data

18 The computer-implemented method in claim 15 wherein said step of dynamically generating said page includes the step of dynamically retrieving said data from said one or more data sources.

19 The computer-implemented method in claim 15 wherein said step of processing said request includes the step of said page server maintaining a connection cache to said one or more data sources.

20 The computer-implemented method in claim 15 wherein said step of processing said request includes the step of logging into said one or more data sources.

21 The computer-implemented method in claim 15 wherein said step of dynamically generating said page includes the step of maintaining a page cache containing said page.

22 The computer-implemented method in claim 15 wherein said page server includes tag-based text templates for configuring said page

23 The computer-implemented method in claim 22 wherein said step of processing said request further includes the step of inserting said dynamically retrieved data from said one or more data sources into said tag-based text templates

24 The computer-implemented method in claim 22 wherein at least one of said tag-based text templates drives a format of the data dynamically retrieved from said one or more data sources in response to said request.

25 The computer-implemented method in claim 22 wherein said tag-based text templates include HTML templates.

26 The computer-implemented method in claim 15 wherein said step of processing said request further includes the step of dynamically updating data at said one or more data sources

27 The computer-implemented method in claim 15 wherein said step of processing said request further includes the step of processing an object handling extension

28 The computer-implemented method in claim 27 wherein said object handling extension is an OLE extension.

29 A computer-implemented method comprising the steps of: transferring a request from an HTTP-compliant device to a dispatcher; maintaining dynamic information regarding data sources a given page server may access; dispatching said request to an appropriate page server based on said request and based on said dynamic information, said page server receiving said request and



US 6,415,335 B1

11

releasing said HTTP-compliant device to process other requests;  
processing said request, said processing being performed by said page server while said HTTP-compliant device concurrently processes said other requests; and

12

dynamically generating a page in response to said request, said page including data dynamically retrieved from one or more data sources.

\* \* \* \* \*

**BAKER BOTTS** LLP

2001 ROSS AVENUE  
DALLAS, TEXAS  
75201-2980  
TEL +1 214.953.6500  
FAX +1 214.953.6503  
www.bakerbotts.com

AUSTIN  
DALLAS  
DUBAI  
HONG KONG  
HOUSTON  
LONDON  
MOSCOW  
NEW YORK  
RIYADH  
WASHINGTON

January 25, 2006

Larry D. Carlson  
TEL +1 214.953.6525  
FAX +1 214.661.4525  
larry.carlson@bakerbotts.com

Mr. Charles Ainsworth  
Clark Lea & Ainsworth  
P.O. Box 98  
Tyler, TX 75710

BY ELECTRONIC MAIL

Re: *EpicRealm Licensing, LLC v. Autoflex, et al., and EpicRealm Licensing, LLC v. Franklin Covey, et al.*; Case Nos. 2:05CV00163-DF, and 2:05CV00356-DF (consolidated); in the United States District Court for the Eastern District of Texas, Marshall Division

Dear Charles:

This is in response to your letter of January 24.

Our pre-suit investigation for Clark Consulting, Inc. focused on the website [www.clarkconsulting.com](http://www.clarkconsulting.com). Header responses and other information available to us established that in responding to requests received by this website for webpages containing dynamic content, Clark generated such pages using Apache and Tomcat servers configured in a manner that infringed claims of the epicRealm patents.

In your January 24, letter, you advise us of three additional websites that Clark owns and operates that you claim use IIS server software as opposed to Apache and/or Tomcat servers.\* In your letter, you ask whether the systems and methods employed by these websites for managing dynamic webpage generation requests infringe the epicRealm patents. We are not in a position at this time to provide you with a definitive answers to that question. There are a couple of reasons why that is so. First, as mentioned above, our pre-suit investigation focused on [www.clarkconsulting.com](http://www.clarkconsulting.com), and header responses generated by that website consistently identified Apache and Tomcat servers and never identified any IIS servers. Second, unlike the open source Apache and Tomcat software, which is in the public domain, IIS server software is proprietary and not publicly available.

\* You appear to have an incorrect URL for the first such site. We believe the correct URL is <http://surveys.clarkconsulting.com/login-verification.asp>. The website you identify – <http://www.clarkconsulting.com/services/surveys/sechips/index.shm>, – generates a header response that identifies Apache and Tomcat server software.

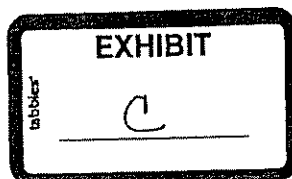

BAKER BOTTS LLP

- 2 -

January 25, 2006

The contention in the first page of your letter that only systems that utilize Apache and/or Tomcat web server software or their equivalent can infringe the epicRealm patents is incorrect. Certainly, a system or method that employs IIS service software instead of Apache or Tomcat servers could, if used to generate webpages with dynamic content, be configured in a way that would infringe the claims of the epicRealm patents.

In response to your question whether Clark is "required to provide [epicRealm] disclosures with regard to web-sites that are IIS software servers only," we believe the answer is Yes. Such disclosures, in particular a complete and full document production, should answer the infringement issue.

As I stated in our brief phone conversation this afternoon, it is not true that other defendants have requested an extension of time until February 16 to respond to our request for production. No defendant has made such a request. In our phone conversation, you made such a request on behalf of all defendants. I am not inclined to agree. The reason is that we originally served our document request on the Autoflex defendants by letter dated June 24, 2005, and on the Franklin Covey defendants (including you) by letter dated September 23, 2005. The Autoflex defendants have had more than seven months to gather these documents for production. The Franklin Covey defendants (including you) have had more than four months. That seems like plenty of time.

Charles, if you have any questions, please give me a call.

Very truly yours,

*Larry D. Carlson*

Larry D. Carlson

*by permission*

*Ryan Lovelace*

LDC:ldm