

~~COPY FOR JUDGE~~

IN THE UNITED STATES DISTRICT COURT
FOR THE SOUTHERN DISTRICT OF FLORIDA

THE CARLEIGH RAE CORPORATION,

Plaintiff

Civil Action No.

03 - 61798

v.

**CIV - SEITZ
MAGISTRATE
BANDSTRA**

**NIGHT BOX
FILED**

CUSTOM BUOYANCY, INC.,
a California Corporation,

MA
SEP 30 2003

Defendant

CLARENCE MADDOX
CLERK, USDC/SDFL/FTL

VERIFIED COMPLAINT

For its complaint herein, Plaintiff THE CARLEIGH RAE CORPORATION (Plaintiff) avers as follows.

1. This is an action for patent infringement of United States Letters Patent No. 5,855,454, No. 6,530,725 and No. 6,558,082 of which Plaintiff is the Assignee.
2. Plaintiff is a corporation organized and existing under the laws of the State of Florida and having its principal place of business in Fort Lauderdale, Florida.
3. Upon information and belief, Defendant CUSTOM BUOYANCY, INC., is a corporation organized and existing under the laws of the State of California and having its principal place of business at Torrance, California.
4. Defendant transacts or has transacted business within this judicial district for its individual gain and benefit, and is subject to the jurisdiction of this Court.

1/10

JURISDICTION AND VENUE

5. This is an action which arises under the Patent Laws of the United States, United States Code, Title 35.

6. This Court has jurisdiction over the claims Plaintiff is asserting under 28 U.S.C. §1338 and 1400.

7. Venue is proper under 28 U.S.C. §1391 (b).

FACTUAL BACKGROUND

8. For many years, Plaintiff, and/or its assignors, have been engaged in the development, manufacture and sale of water safety and performance improvement products particularly for use in the dive, marine and boating industry.

9. Plaintiff, and/or its assignors, have expended considerable time, effort and moneys in the development of their various unique and novel products.

10. As is customary to protect its investment in the development of its many unique and novel products, Plaintiff, and/or its assignors, have filed numerous patent applications for United States Letters Patent, which include, but are not limited to, Application Serial No. 08/645,206 filed May 13, 1996, Application Serial No. 09/255,892 filed January 4, 1999, and Application Serial No. 09/641,932 filed August 18, 2000. These applications were filed in the name of William L. Courtney and Robert M. Carmichael.

11. The aforementioned applications were allowed by the United States Patent and Trademark Office and granted respectively on January 5, 1999 as United States Letters Patent No. 5,855,454 (the '454 Patent), March 11, 2003 as United States Patent 6,530,725 (the '725 Patent), and May 6, 2003

as United States Letters Patent 6,558,082 (the '082 Patent). A true copy of the '454, '725 and '082 patents are attached hereto as Exhibits A, B and C respectively.

12. All three patents were assigned to Plaintiff by an assignment executed on August 14, 2003. A true copy of the assignment is attached hereto as Exhibit D.

13. Plaintiff or its inventor principals/assignors have continuously been the owners of all right, title and interest in and to the inventions of the '454 Patent, the '725 Patent and the '082 Patent.

14. Since the issuance of the Patents, Plaintiff and/or its assignors, have complied with all marking requirements under Title 35 U.S.C.

15. Plaintiff, and/or its assignors, placed Defendant on actual notice of Plaintiff's rights by hand delivering a copy of the '454 Patent personally to Defendant at the Diving Equipment and Marketing Association Conference on approximately October 23, 2002.

16. With full knowledge of Plaintiff, and/or its assignor's patent rights, Defendant is making, using and selling, within this District and elsewhere, products that infringe the '454 Patent, the '725 Patent and/or the '082 Patent.

17. All conditions precedent to bringing this action have either occurred or been waived.

18. Plaintiff has been required to retain the services of the undersigned counsel and agreed to pay them a reasonable fee for which Defendant is responsible pursuant to Title 35 U.S.C., especially in view of the willful and intentional nature of Defendant's infringement.

COUNT ONE
PATENT INFRINGEMENT
(U.S. PATENT NO. 5,855,454)

19. Plaintiff repeats and realleges Paragraphs 1 through 18 of this Complaint as if fully set forth

herein.

20. Defendant has infringed the '454 Patent since it issued by making, using and/or selling products covered by one or more claims of the '454 Patent in the United States and its territories and specifically in this Southern District of Florida, and will continue such infringement unless enjoined by this Court.

21. Given Defendant's actual knowledge of Plaintiff and/or assignor's patent rights, Defendant's acts are intentional and willful in nature, and done with full knowledge of causing substantial harm to Plaintiff.

22. As a result of Defendant's willful activities and infringement, Plaintiff has suffered and will continue to suffer grievous damage.

23. Plaintiff has no adequate remedy at law.

WHEREFORE Plaintiff prays for:

A. A finding by this Court that Defendants have infringed United States Letters Patent No. 5,855,454;

B. An award against Defendant for damages suffered by Plaintiff as a result of Defendant's acts of infringement with prejudgment interest;

C. An award of Defendant's profits from Defendant's acts of infringement;

D. A finding by this Court that any award by trebled in view of Defendant's willful and intentional infringement;

E. An order enjoining Defendant and its subsidiaries, related companies, parent, agents, officers, directors and employees, and all others acting in concert or participation with it, from infringing United States Letters Patent No. 5,855,454;

States Letters Patent No. 5,855,454;

F. An award to Plaintiff of attorney's fees, costs and expenses in this action; and

G. Any other and further relief as this Court may deem just and proper under the conditions.

COUNT TWO
PATENT INFRINGEMENT
(U.S. PATENT NO. 6,530,725)

24. Plaintiff repeats and realleges Paragraphs 1 through 18 of this Complaint as if fully set forth herein.

25. Defendant has infringed the '725 Patent since it issued by making, using and/or selling products covered by one or more claims of the '725 Patent in the United States and its territories and specifically in this Southern District of Florida, and will continue such infringement unless enjoined by this Court.

26. As a result of Defendant's infringement, Plaintiff has suffered and will continue to suffer grievous damage.

27. Plaintiff has no adequate remedy at law.

WHEREFORE Plaintiff prays for:

A. A finding by this Court that Defendants have infringed United States Letters Patent No. 6,530,725;

B. An award against Defendant for damages suffered by Plaintiff as a result of Defendant's acts of infringement with prejudgment interest;

C. An award of Defendant's profits from Defendant's acts of infringement;

D. An order enjoining Defendant and its subsidiaries, related companies, parent, agents, officers,

directors and employees, and all others acting in concert or participation with it, from infringing United States Letters Patent No. 6,530,725;

E. An award to Plaintiff of attorney's fees, costs and expenses in this action; and

F. Any other and further relief as this Court may deem just and proper under the conditions.

COUNT THREE
PATENT INFRINGEMENT
(U.S. PATENT NO. 6,558,082)

29. Plaintiff repeats and realleges Paragraphs 1 through 18 of this Complaint as if fully set forth herein.

30. Defendant has infringed the '082 Patent since it issued by making, using and/or selling products covered by one or more claims of the '082 Patent in the United States and its territories and specifically in this Southern District of Florida, and will continue such infringement unless enjoined by this Court.

31. As a result of Defendant's infringement, Plaintiff has suffered and will continue to suffer grievous damage.

32. Plaintiff has no adequate remedy at law.

WHEREFORE Plaintiff prays for:

A. A finding by this Court that Defendants have infringed United States Letters Patent No. 6,558,082;

B. An award against Defendant for damages suffered by Plaintiff as a result of Defendant's acts of infringement with prejudgment interest;

C. An award of Defendant's profits from Defendant's acts of infringement;

directors and employees, and all others acting in concert or participation with it, from infringing United States Letters Patent No. 6,558,082;

E. An award to Plaintiff of attorney's fees, costs and expenses in this action; and

F. Any other and further relief as this Court may deem just and proper under the conditions.

I hereby verify that the allegations set forth herein are true and correct.

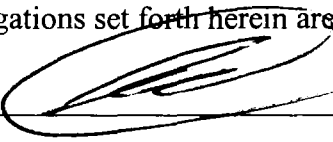

Robert Carmichael, Pres.
Carleigh Rae Corp.

STATE OF FLORIDA
COUNTY OF BROWARD

I HEREBY CERTIFY that on this day before by, an officer duly qualified to take acknowledgments, personally appeared

Robert Carmichael

- 1. { } to me personally known to be the person described herein and who executed the foregoing instrument, and acknowledged under oath that he executed the same or
- 2. { } who produced identification in the form of _____, and acknowledged under oath before me that he executed the same.

WITNESS my hand and official seal in the County and State aforesaid this 26 day of

Sept, 2003

Notary Public

John F. Bradley
(Type/Print Name of Notary)

My Commission Expires



John F. Bradley
MY COMMISSION # DD053204 EXPIRES
November 2, 2005
BONDED THRU TROY FAIN INSURANCE, INC.

THE CARLEIGH RAE CORPORATION

By: _____

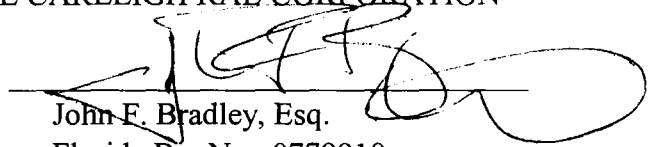

John F. Bradley, Esq.
Florida Bar No. 0779910
Jamin D. Rubenstein, Esq.
Florida Bar No. 0514284
JOHN BRADLEY & ASSOCIATES P.A.
Attorneys for Plaintiff
1215 East Broward Boulevard
Suite 200
Fort Lauderdale, Florida 33301
Phone: (954) 523-6160
Fax: (954) 523-6190
Email: jfblaw@bellsouth.net

Date: 9.26.03

EXHIBIT A

JS005855454A

United States Patent [19]

[11] **Patent Number:** 5,855,454

Courtney et al.

[45] **Date of Patent:** Jan. 5, 1999

[54] **WATER SAFETY AND SURVIVAL SYSTEM**
 [76] Inventors: **William L. Courtney**, 1990 Highway One, Elk, Calif. 95432; **Robert Mammel Carmichael**, 2124 NE, 24th St., Wilton Manors, Fla. 33305

3.811.144	5/1974	Yamanka	441/30
3.877.098	4/1975	Braly	405/186
3.967.459	7/1976	Denis	405/186
4.016.616	4/1977	Walters	405/186
4.054.132	10/1977	Deeds	128/202.14
4.137.585	2/1979	Wright, III	405/193
4.176.418	12/1979	Scott	441/96
4.187.570	2/1980	De Simone	441/37
4.240.371	12/1980	Perry	116/210
4.324.234	4/1982	Maness	128/202.14
4.440.525	4/1984	Peda	405/186
4.446.574	5/1984	Kalomeris	2/338
4.455.718	6/1984	Finnem	405/186
4.560.356	12/1985	Burr	441/80
4.645.465	2/1987	Courtney	441/40
4.681.552	7/1987	Courtney	441/92
4.732.305	3/1988	Courtney et al.	405/186
4.752.263	6/1988	Pritchard et al.	114/88
4.779.554	10/1988	Courtney	114/315
4.889.511	12/1989	Herman	441/88
4.990.115	2/1991	Vorhamer et al.	441/111
5.030.153	7/1991	Bailey	441/115
5.076.575	12/1991	Eylander	405/186 X
5.095.957	3/1992	Herman	441/88
5.249.890	10/1993	Bergstrom	405/186
5.337.935	8/1994	Chambonnet	224/224
5.459.874	10/1995	Meredith	2/67

[21] Appl. No.: **645,206**
 [22] Filed: **May 13, 1996**

Related U.S. Application Data

[63] Continuation-in-part of Ser. No. 149,137, Nov. 8, 1993, Pat. No. 5,516,233, which is a continuation of Ser. No. 870,244, Apr. 17, 1992, abandoned.
 [51] Int. Cl.⁶ **B63C 11/02**
 [52] U.S. Cl. **405/186; 441/108**
 [58] Field of Search **405/186; 441/108, 441/114, 129**

[56] **References Cited**

U.S. PATENT DOCUMENTS

D. 29.490	10/1898	Varnigardini	D3/230
D. 134.542	12/1942	Wax	D3/230
D. 259.151	5/1981	Kishbaugh et al.	D3/224
636.893	11/1899	Burton	441/110
1.216.457	2/1917	Jelalian	441/114
1.410.438	3/1922	Willows et al.	441/80
1.480.417	1/1924	Potter	441/115
1.726.761	9/1929	Palmer	383/119
2.114.301	4/1938	Harrigan	244/148
2.120.420	6/1938	Topper	405/186
3.105.981	10/1963	Bennet	441/92
3.158.300	11/1964	Withee	224/235
3.179.963	4/1965	Peterson	441/115
3.374.636	3/1968	Mason	405/186
3.425.071	2/1969	Frieder et al.	441/40
3.436.777	4/1969	Greenwood	405/186
3.470.570	10/1969	Christiansen	2/338
3.670.509	6/1972	Walters	405/186
3.713.299	1/1973	Duncan	405/186
3.727.250	4/1973	Koehn et al.	405/186
3.747.140	7/1973	Roberts	405/186
3.808.824	5/1974	Johnston et al.	405/186

Primary Examiner—Tamara L. Graysay
Assistant Examiner—Tara L. Mayo
Attorney, Agent, or Firm—Malin, Haley, DiMaggio & Crosby, P.A.

[57] **ABSTRACT**

A counterweight assembly is provided to enhance heads up surface positioning of a person. The assembly includes a weight/ballast member strategically disposed on a cylinder/tank worn by a diver during a dive. The weight member can be attached by several different embodiments. Preferably, the weight member is attached such that the diver cannot release or adjust the weight member while he or she is diving. The weight member rotates the person to ensure heads up surface positioning in the event the person becomes incapacitated. Also provided are several other water safety and survival devices.

19 Claims, 23 Drawing Sheets

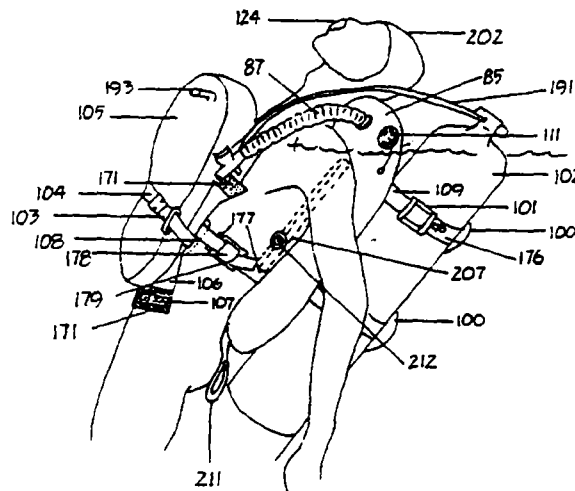

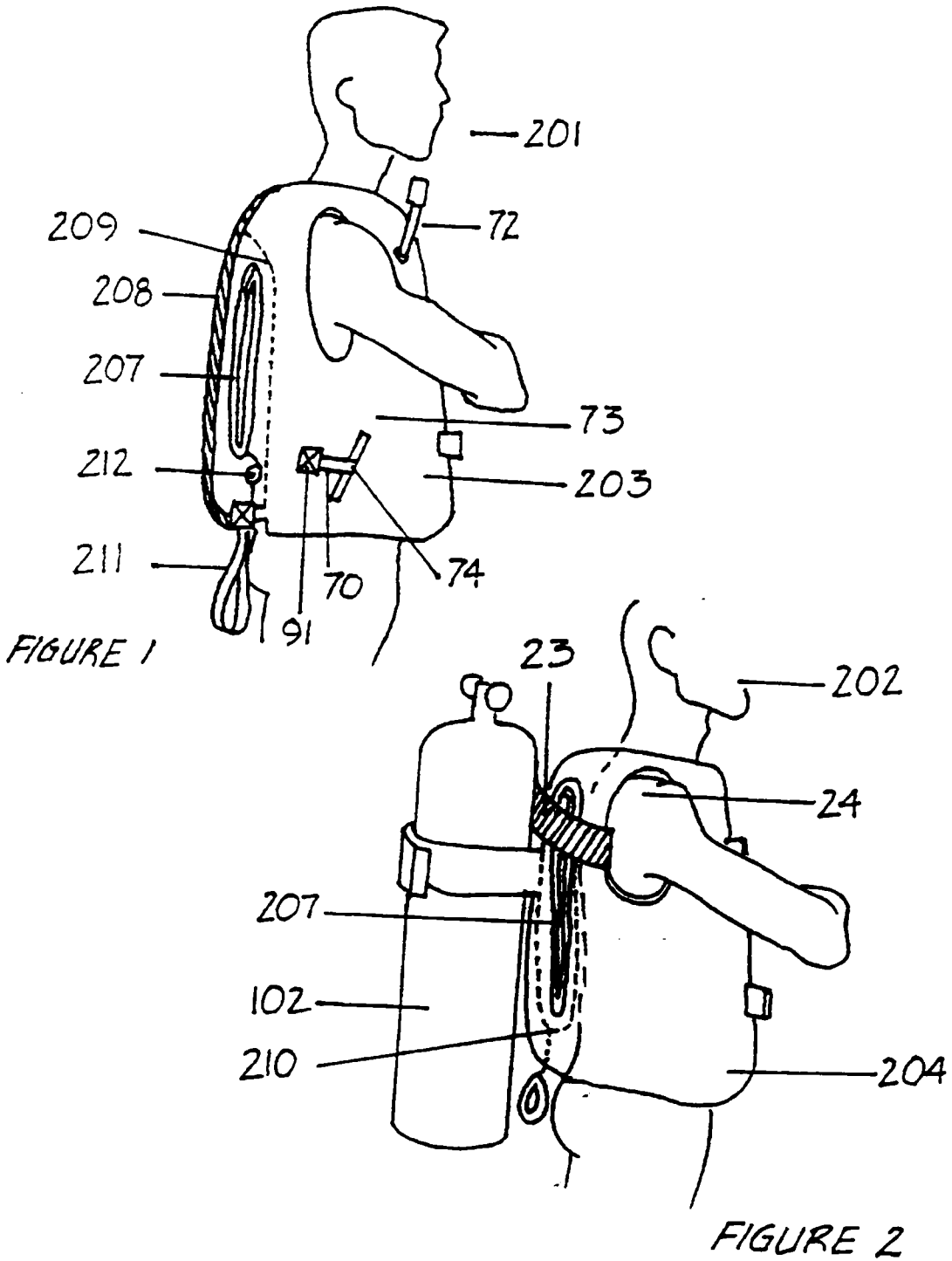

U.S. Patent

Jan. 5, 1999

Sheet 2 of 23

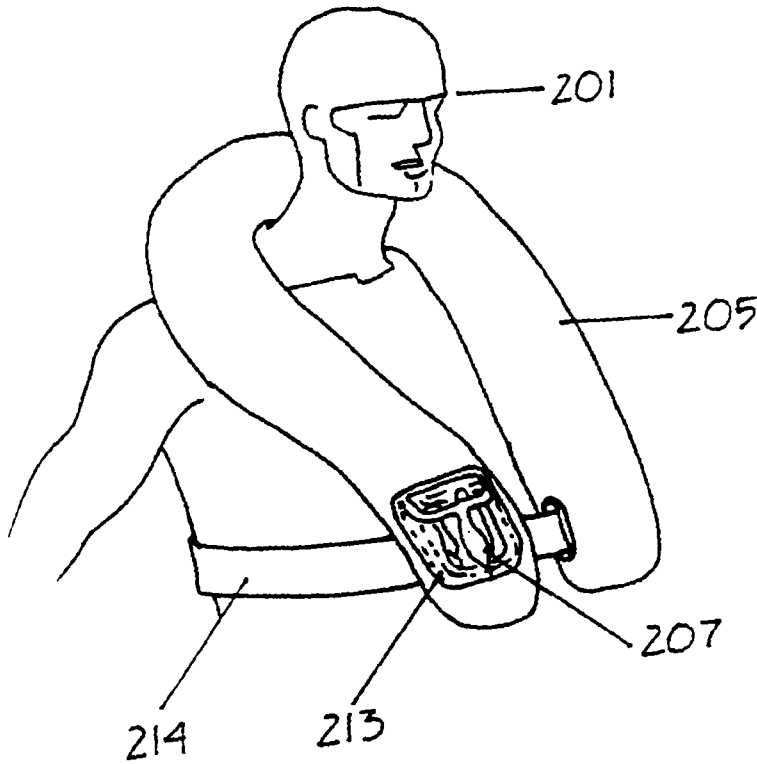

FIGURE 3

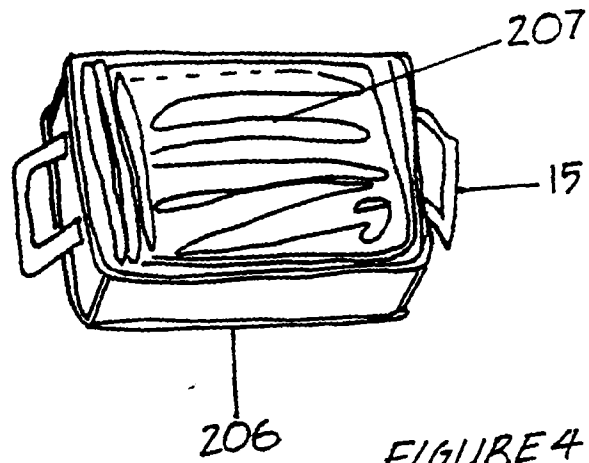
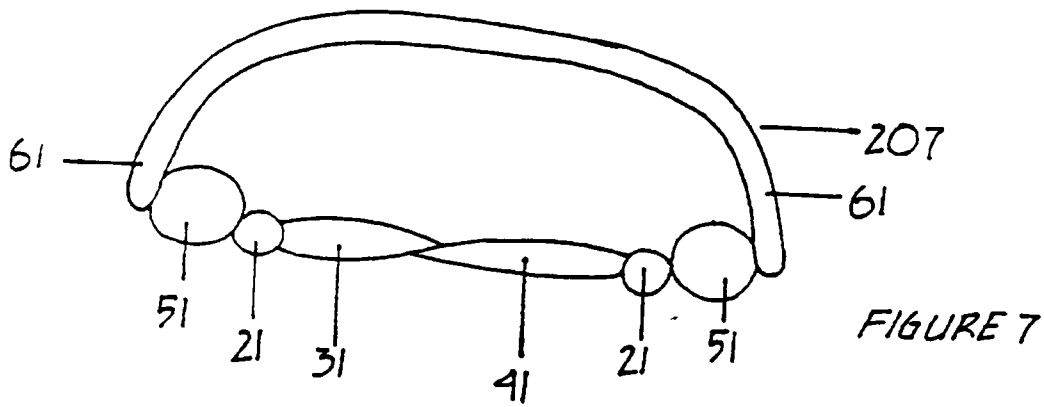
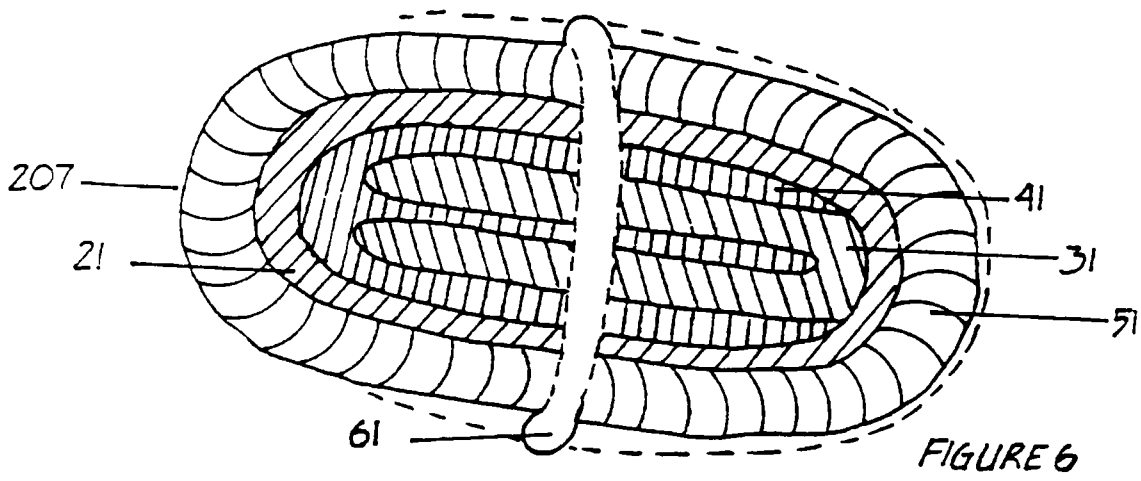
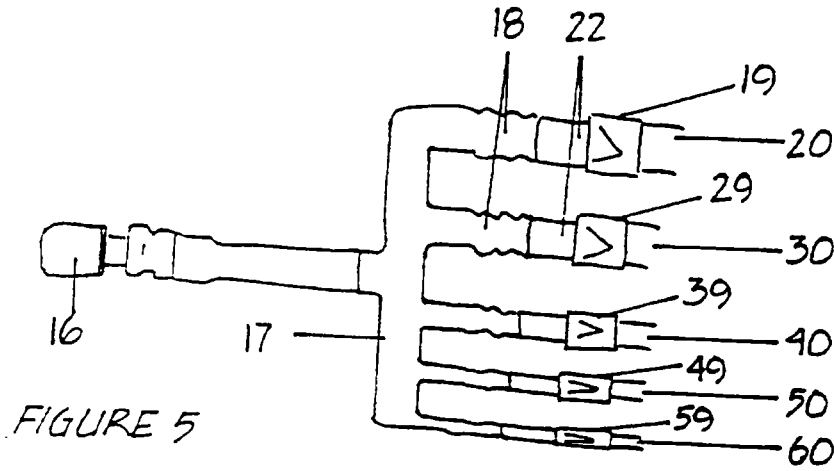

FIGURE 4



U.S. Patent

Jan. 5, 1999

Sheet 4 of 23

5,855,455

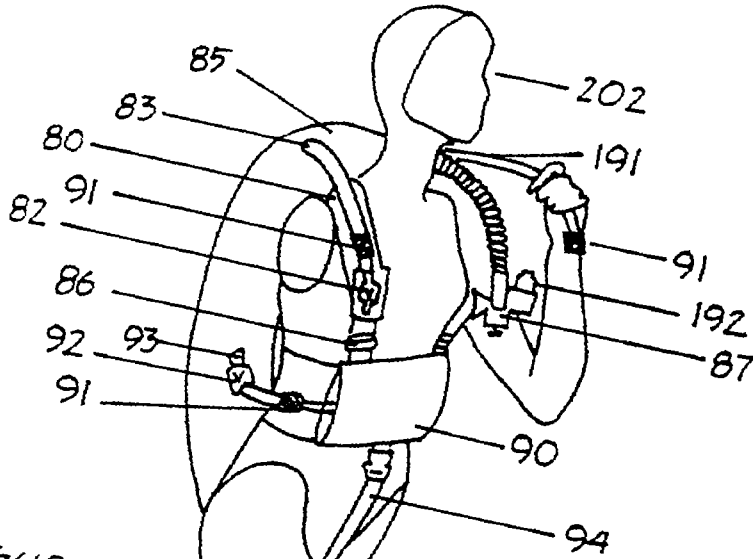

FIGURE 8

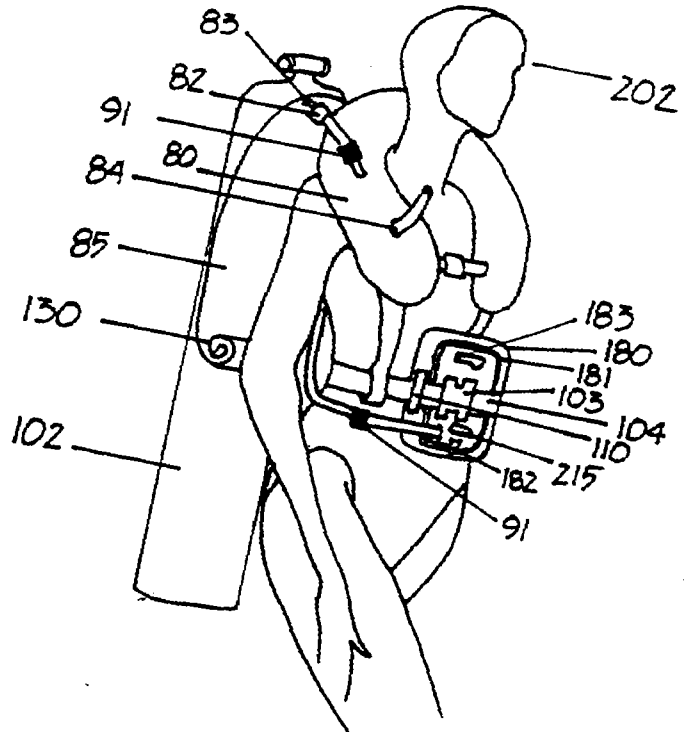

FIGURE 9

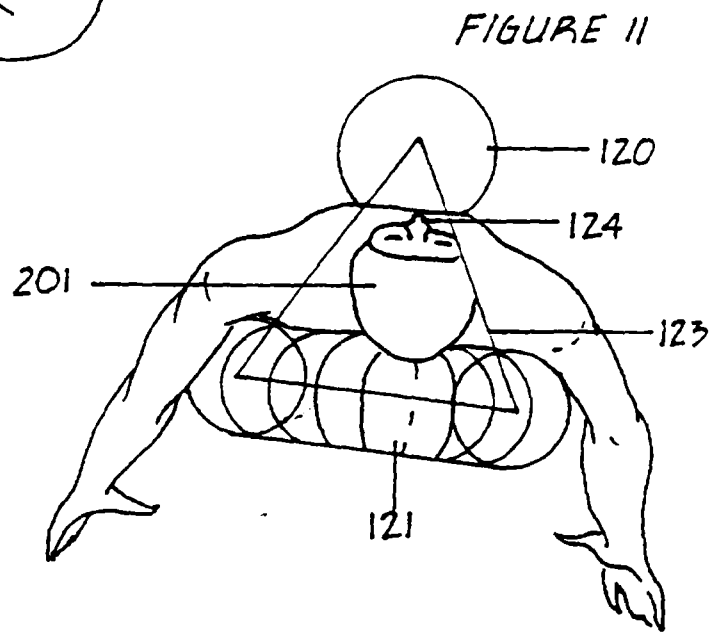
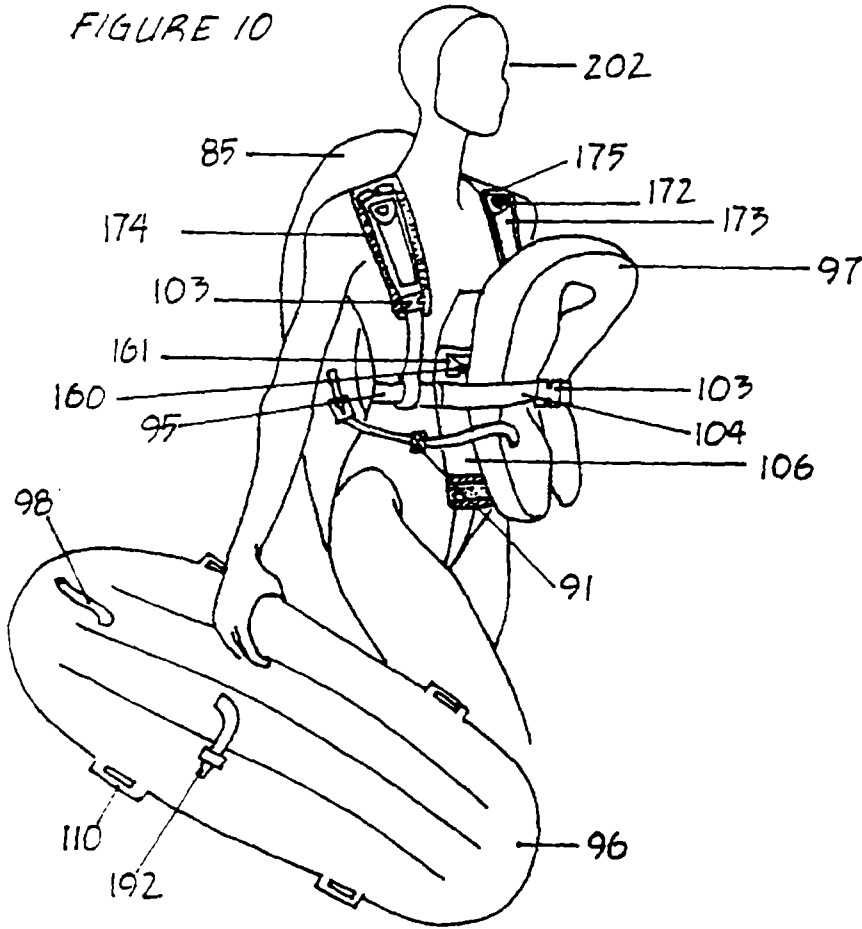
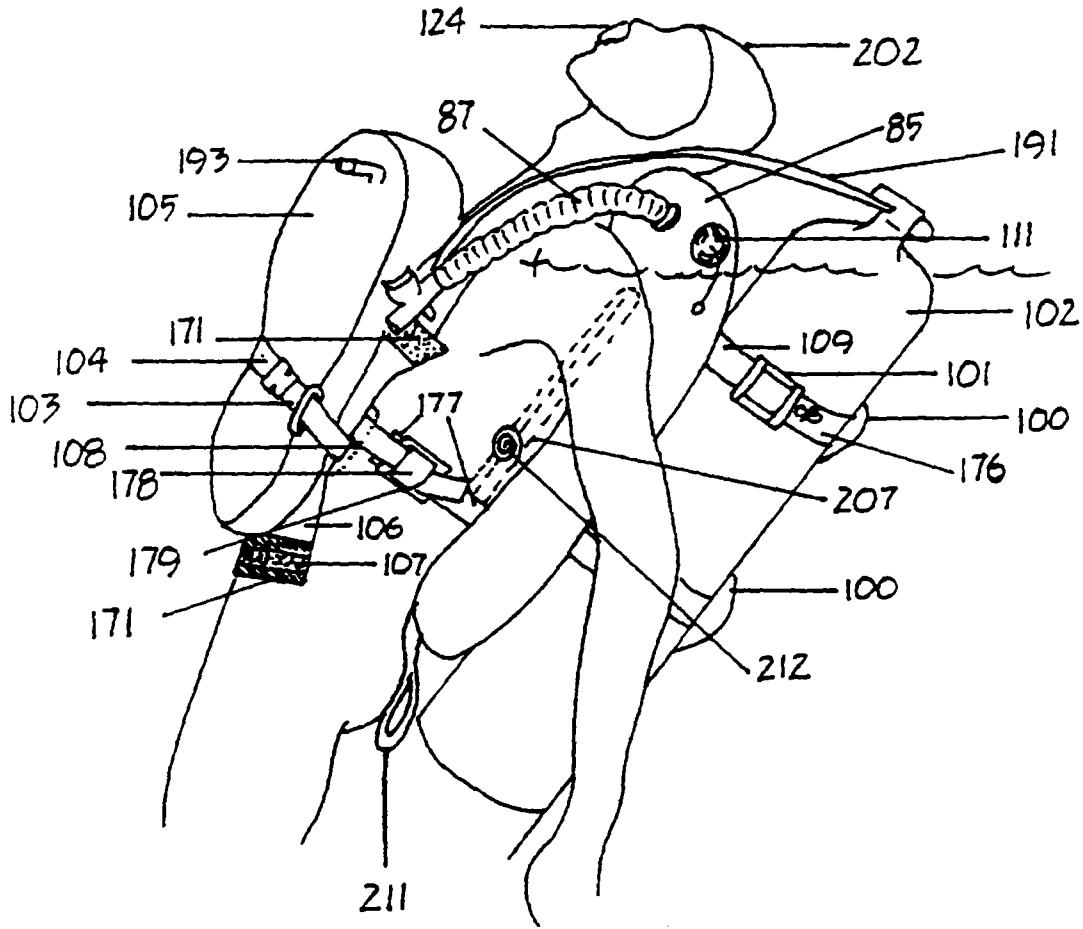

EXHIBIT A
Page 6 of 44 pages

FIGURE 12



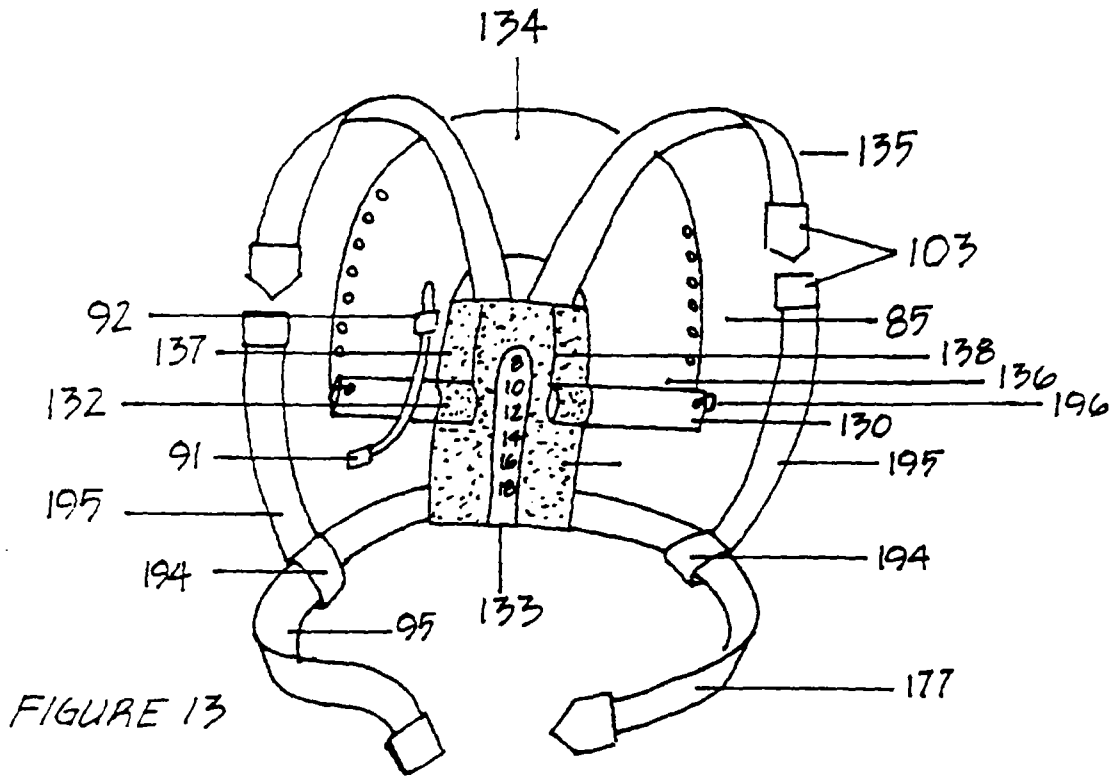

FIGURE 13

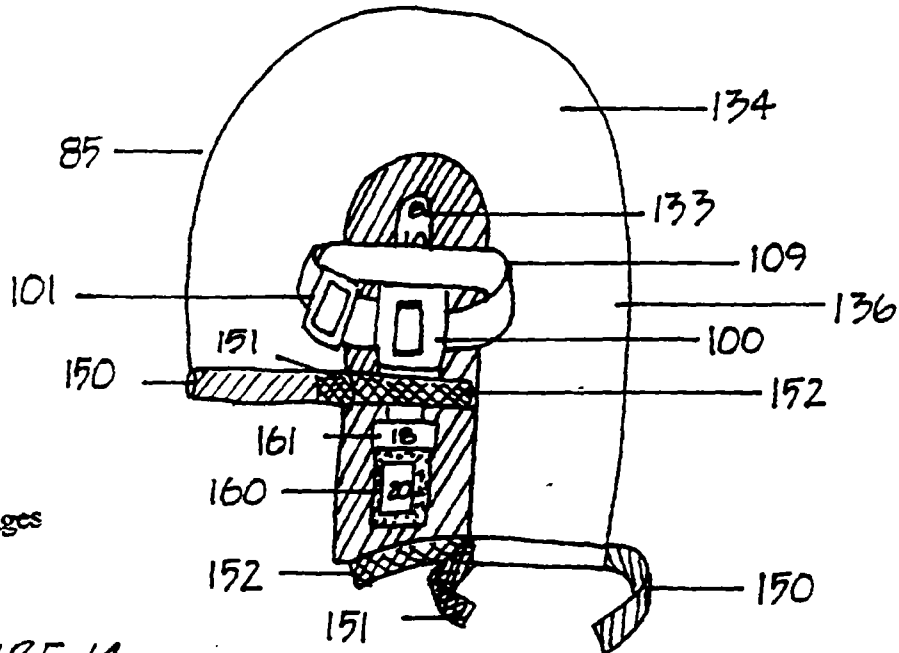
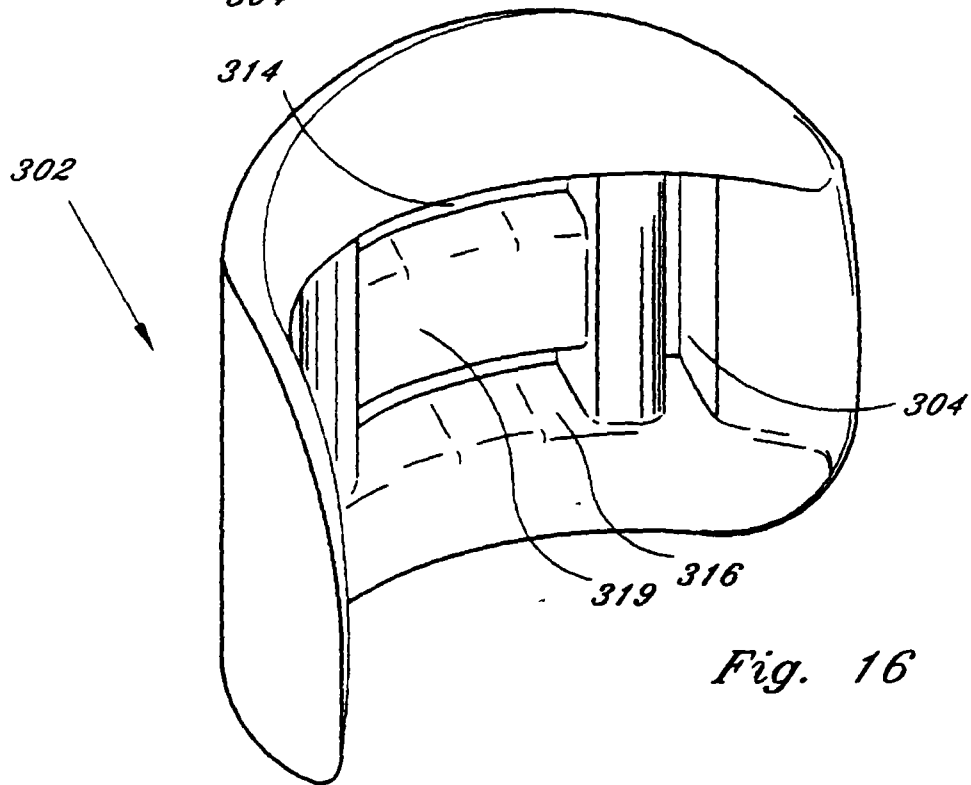
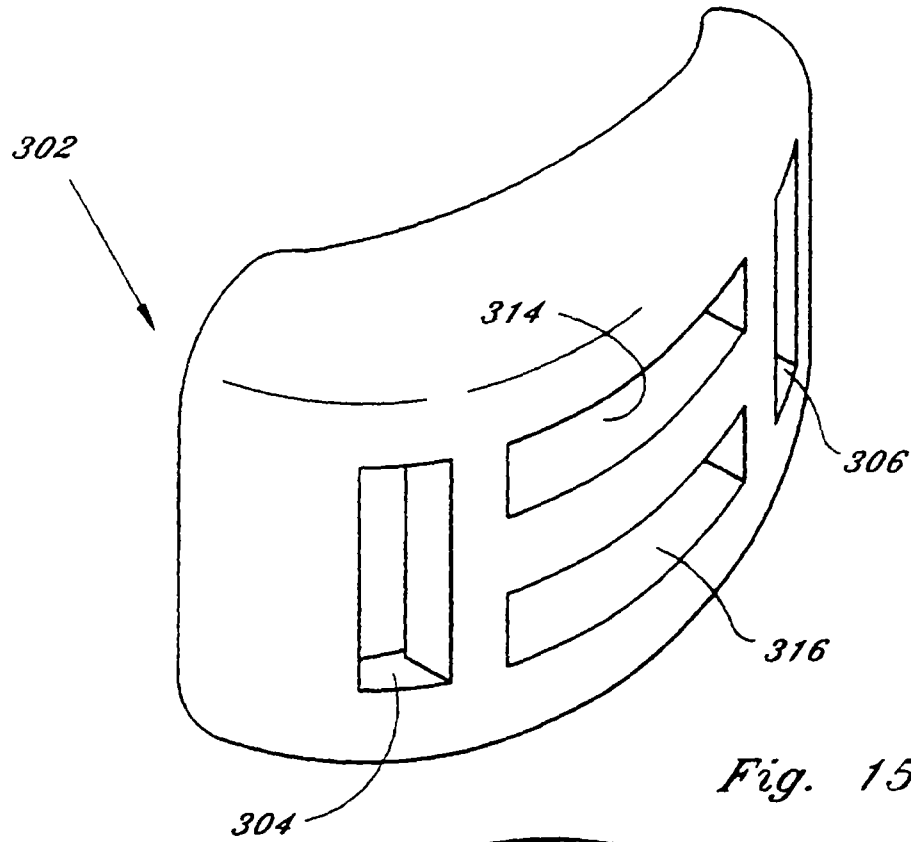

FIGURE 14

EXHIBIT A
Page 8 of 44 pages



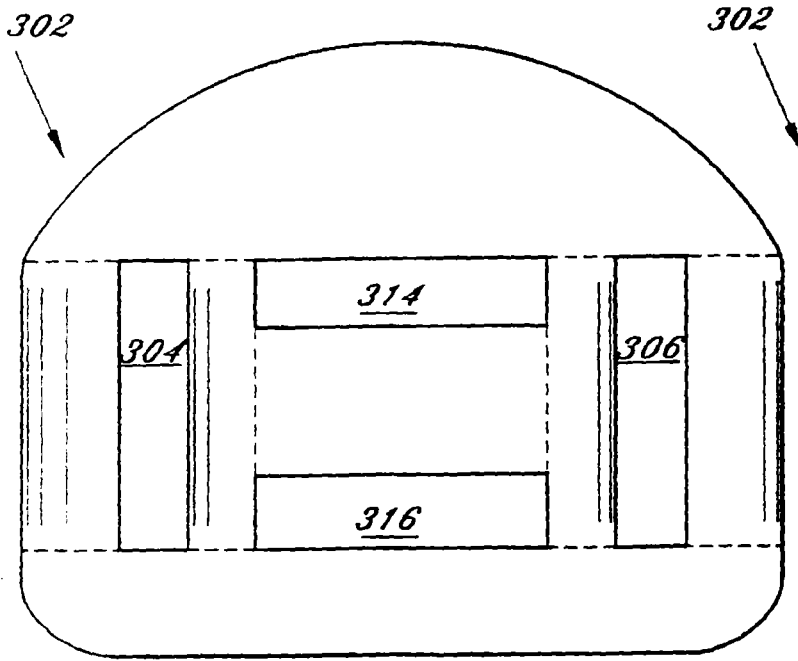

Fig. 17

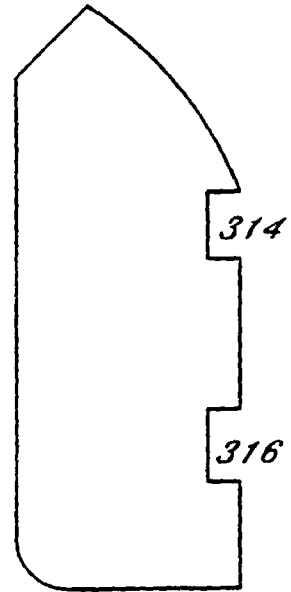

Fig. 19

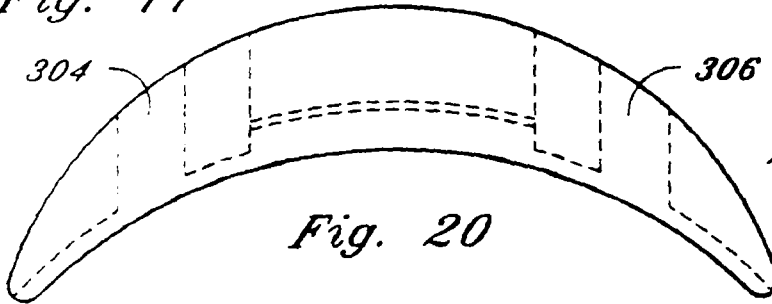

Fig. 20

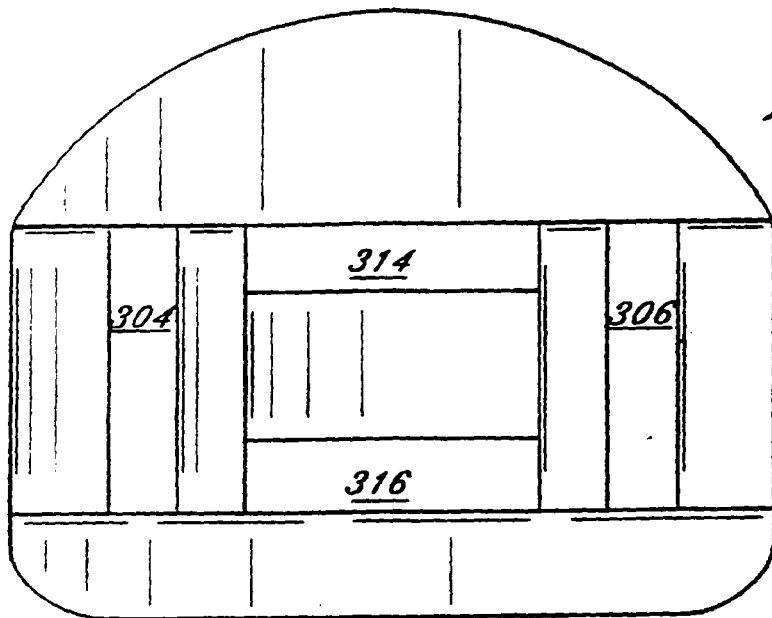
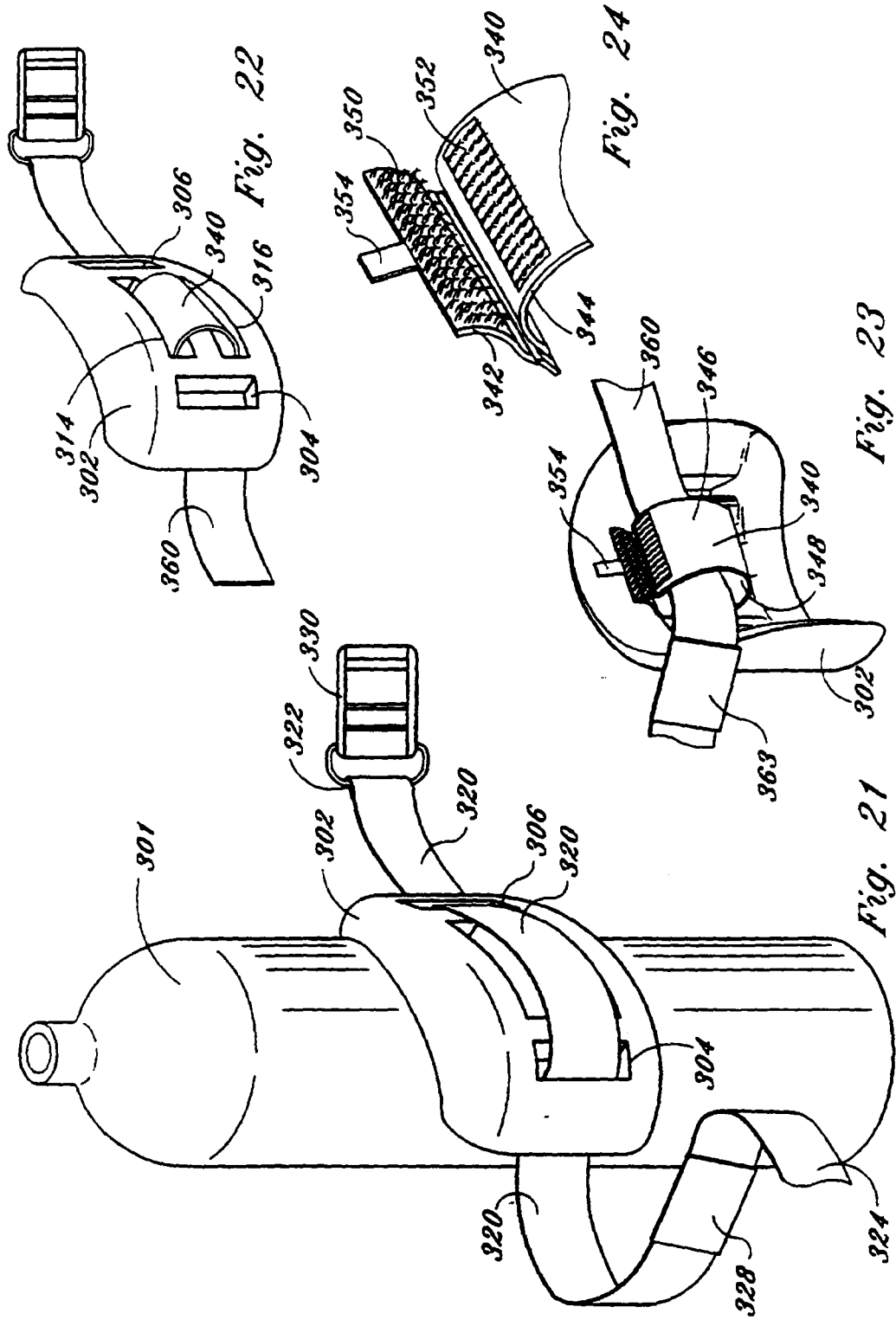

Fig. 18



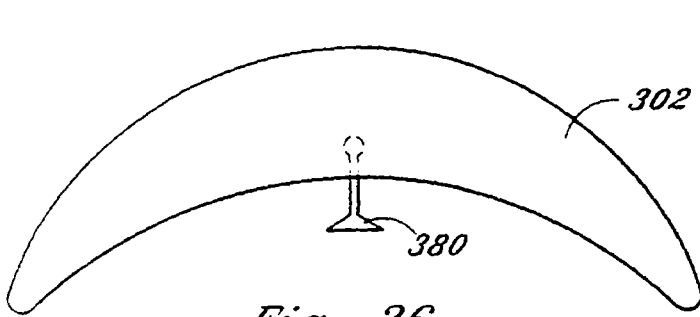

Fig. 26

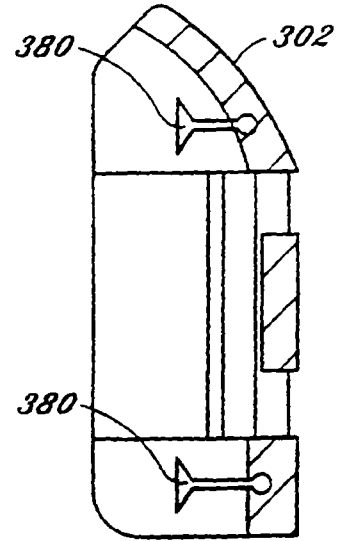

Fig. 27

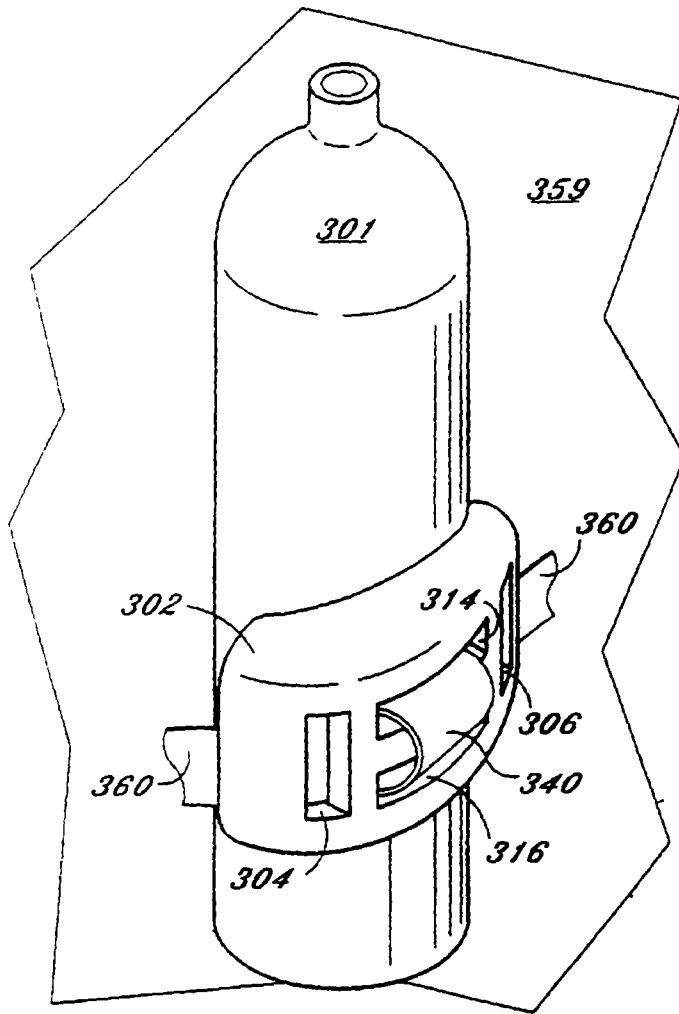
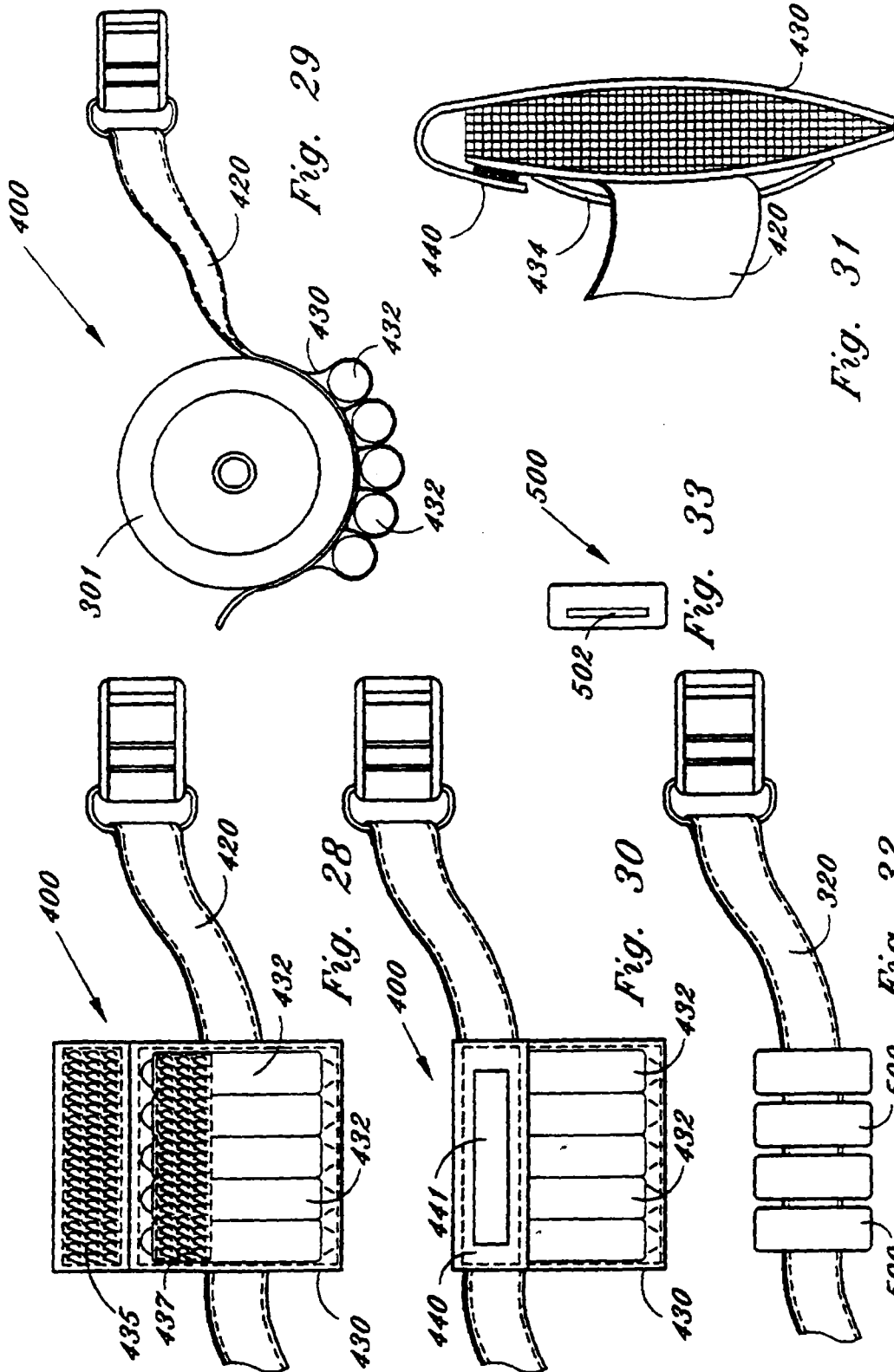

Fig. 25



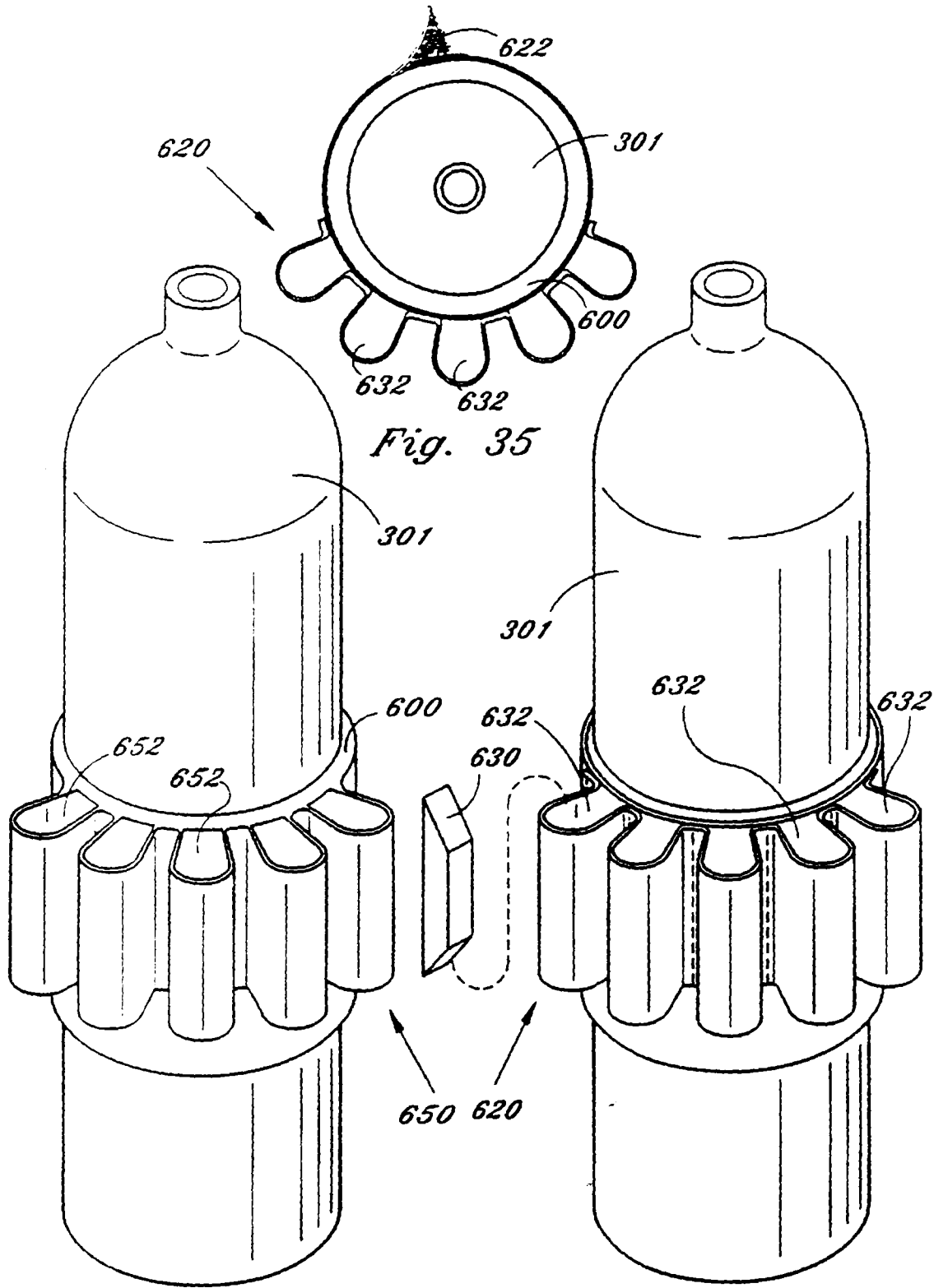

Fig. 35

Fig. 36

Fig. 34

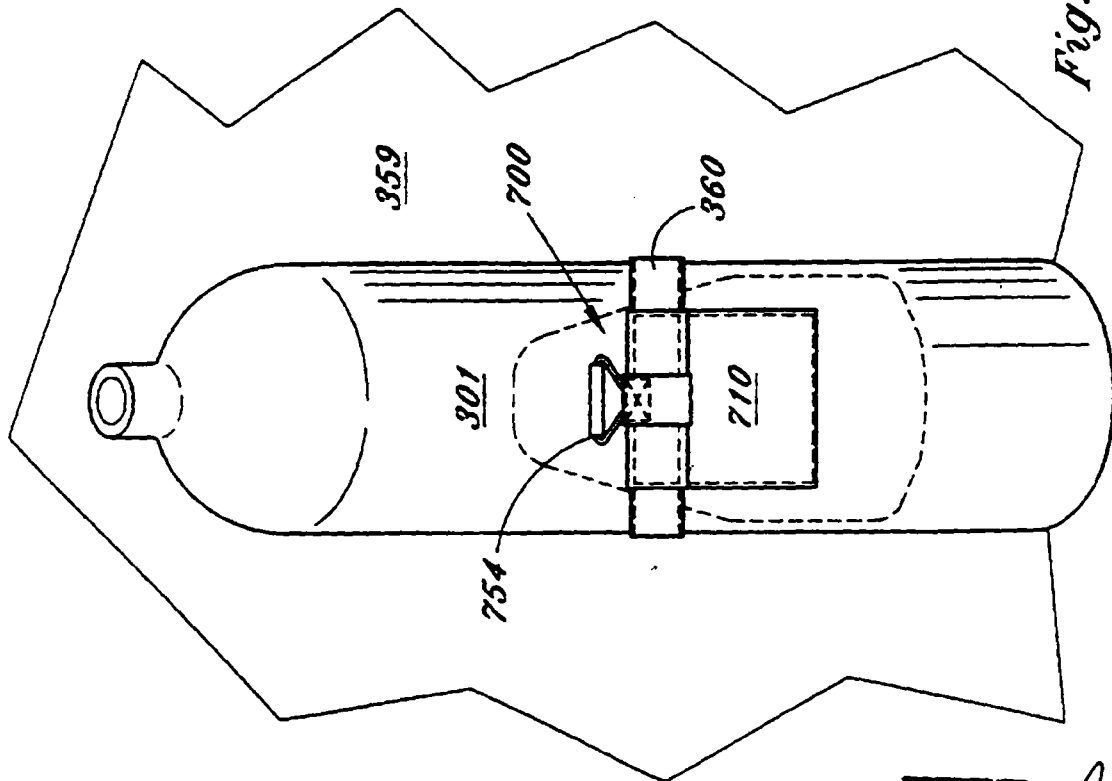

Fig. 37

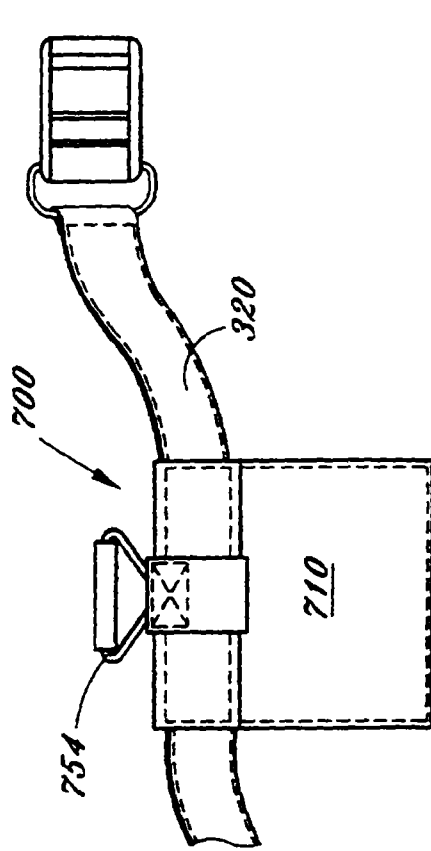

Fig. 38a

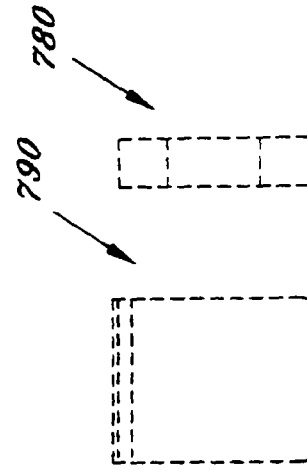

Fig. 38b

Fig. 38c

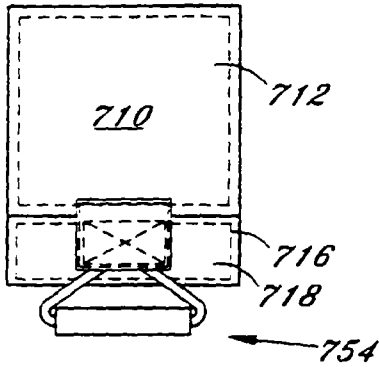

Fig. 39a

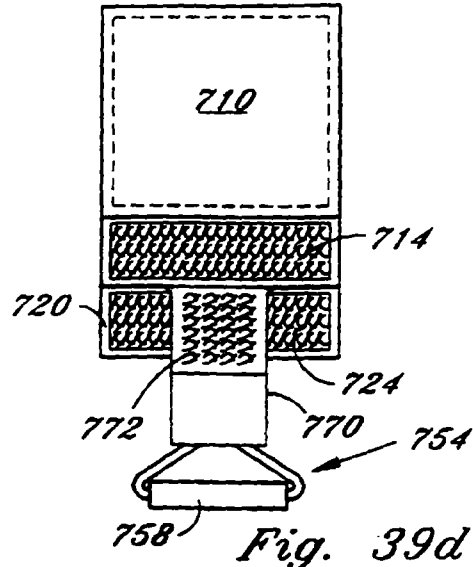

Fig. 39d

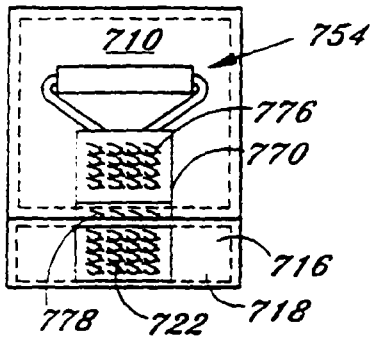

Fig. 39b

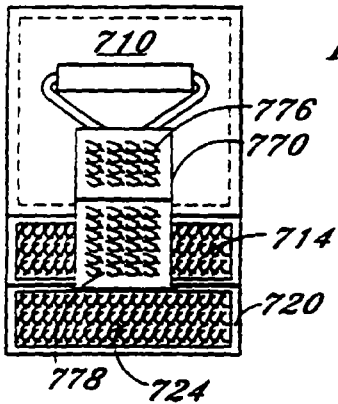
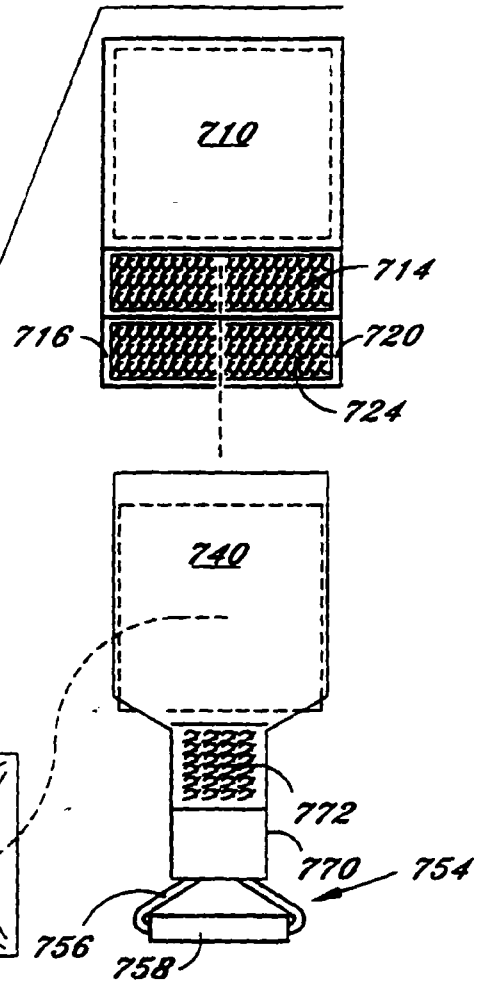
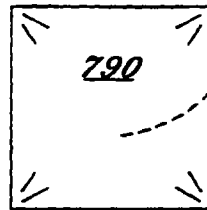
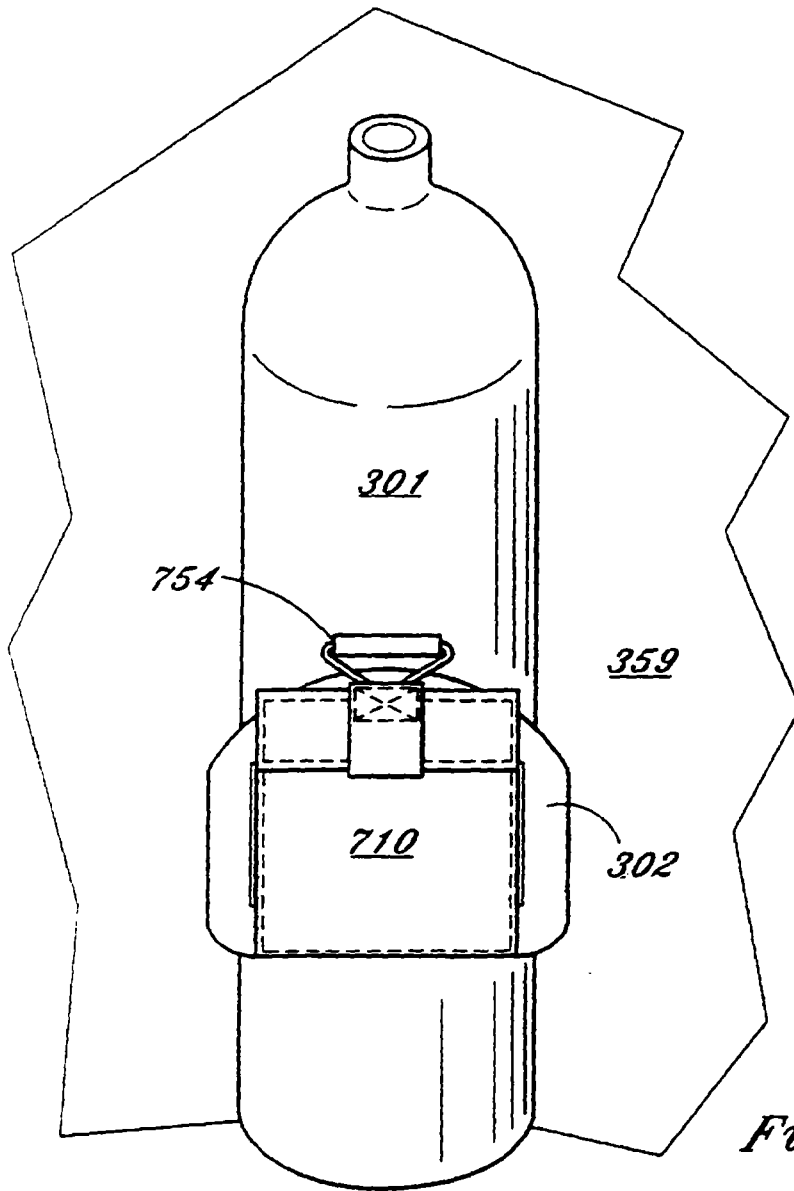
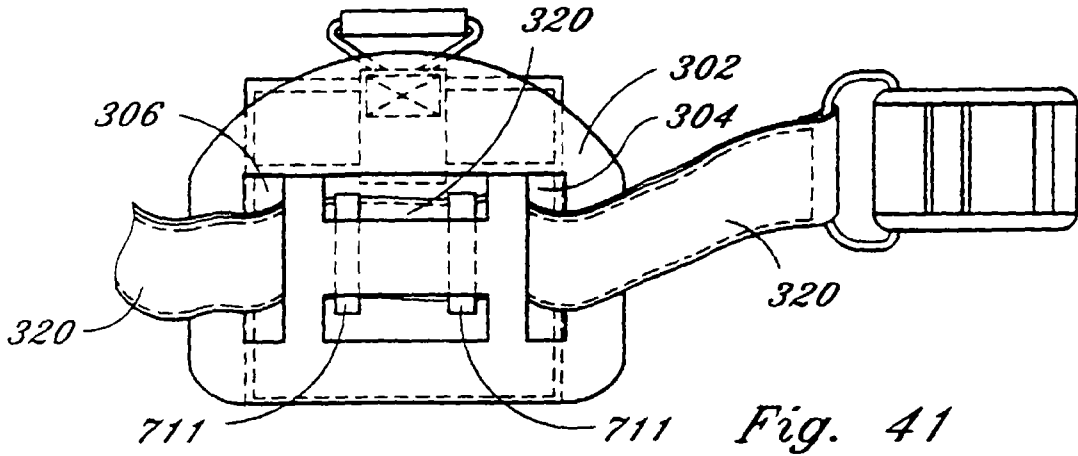

Fig. 39c

Fig. 39e



pages 11 of 44



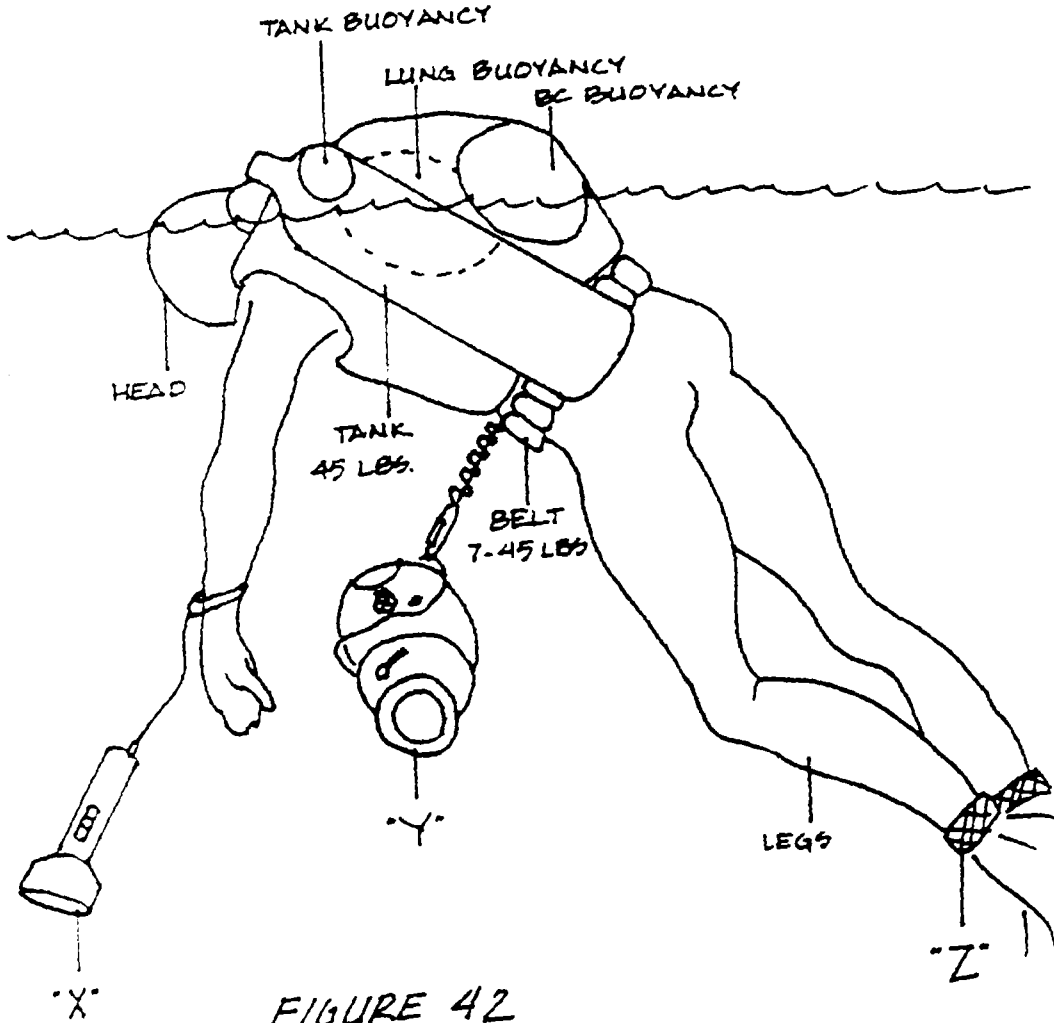

FIGURE 42

FACTORS CONTRIBUTING BALLAST AND BUOYANCY TO DISTRESSED DIVER.

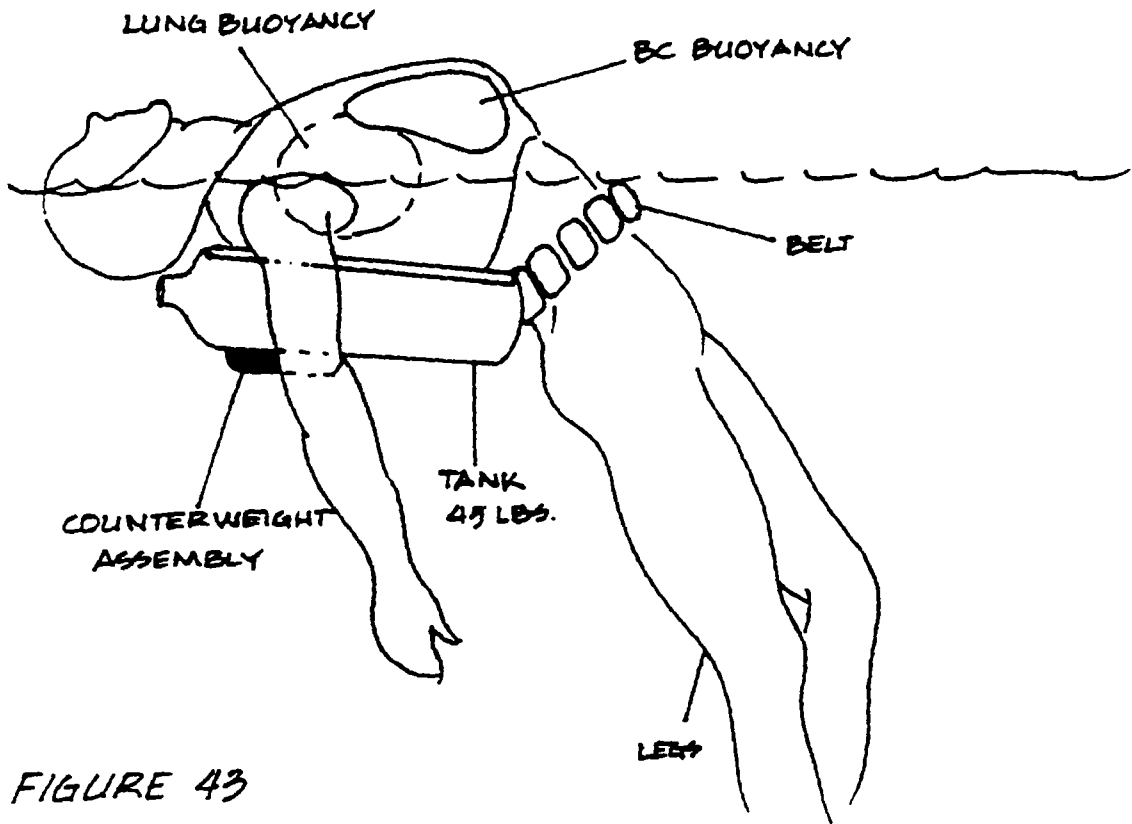

FIGURE 43

DIVER IN BALANCE

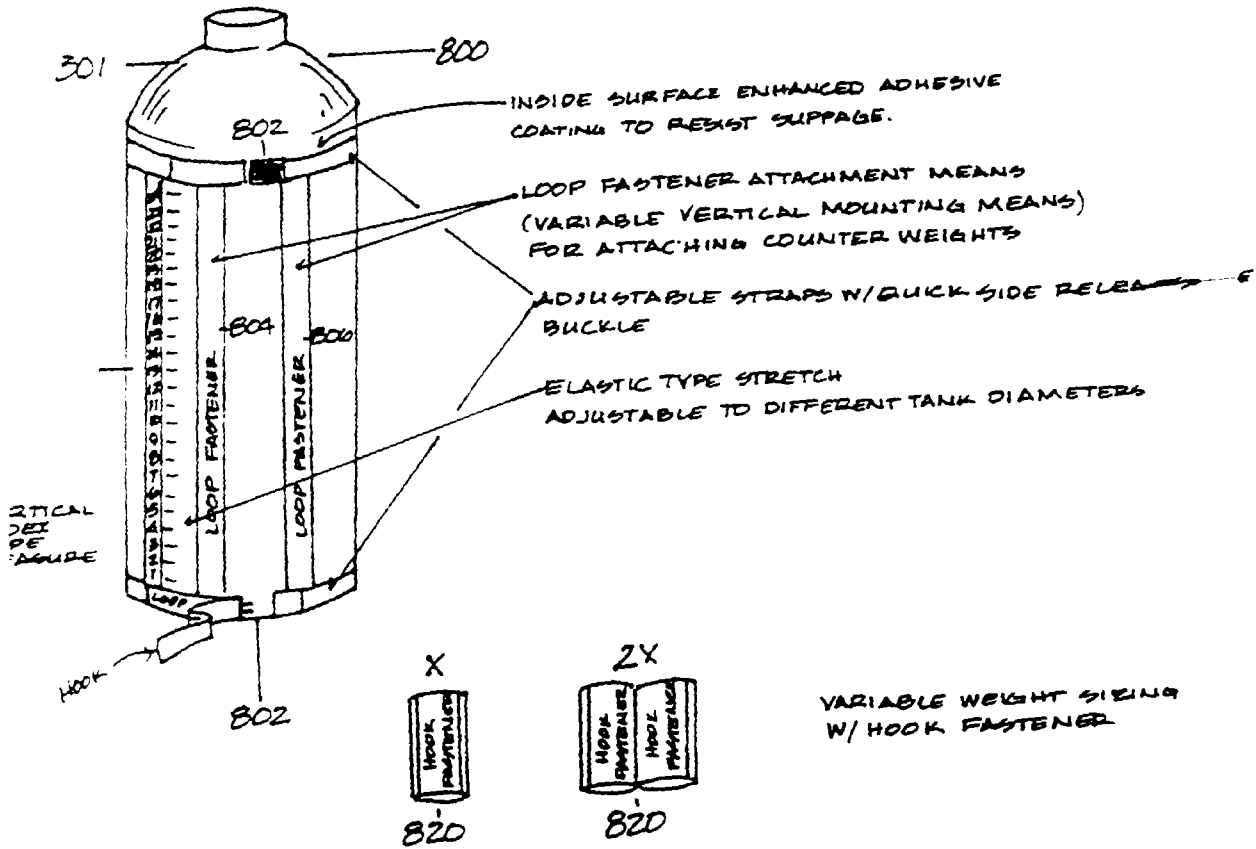
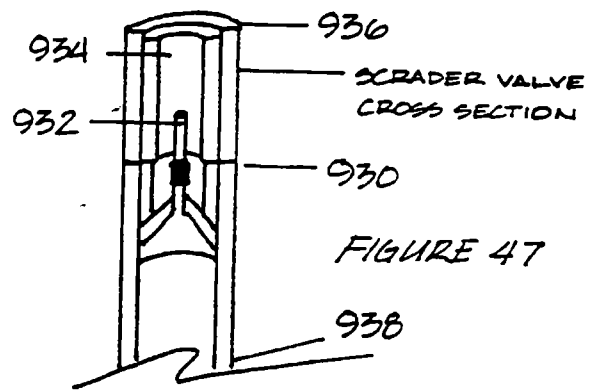
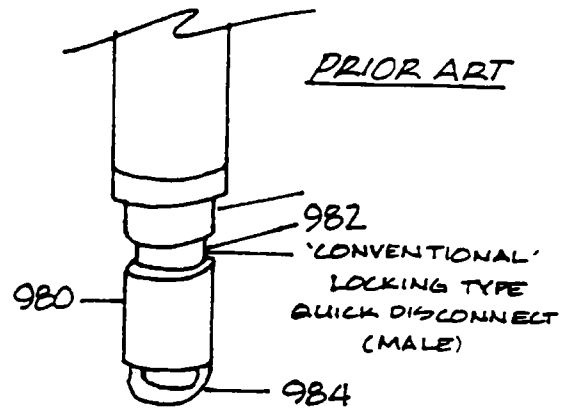
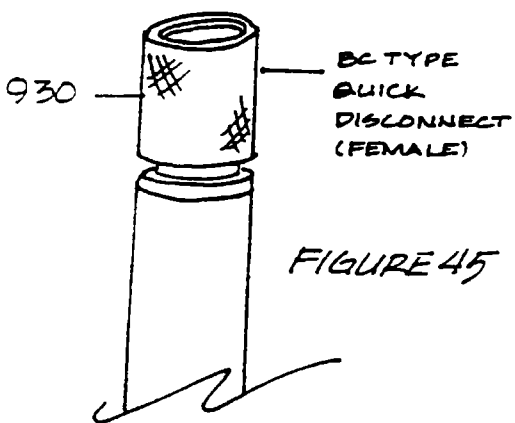
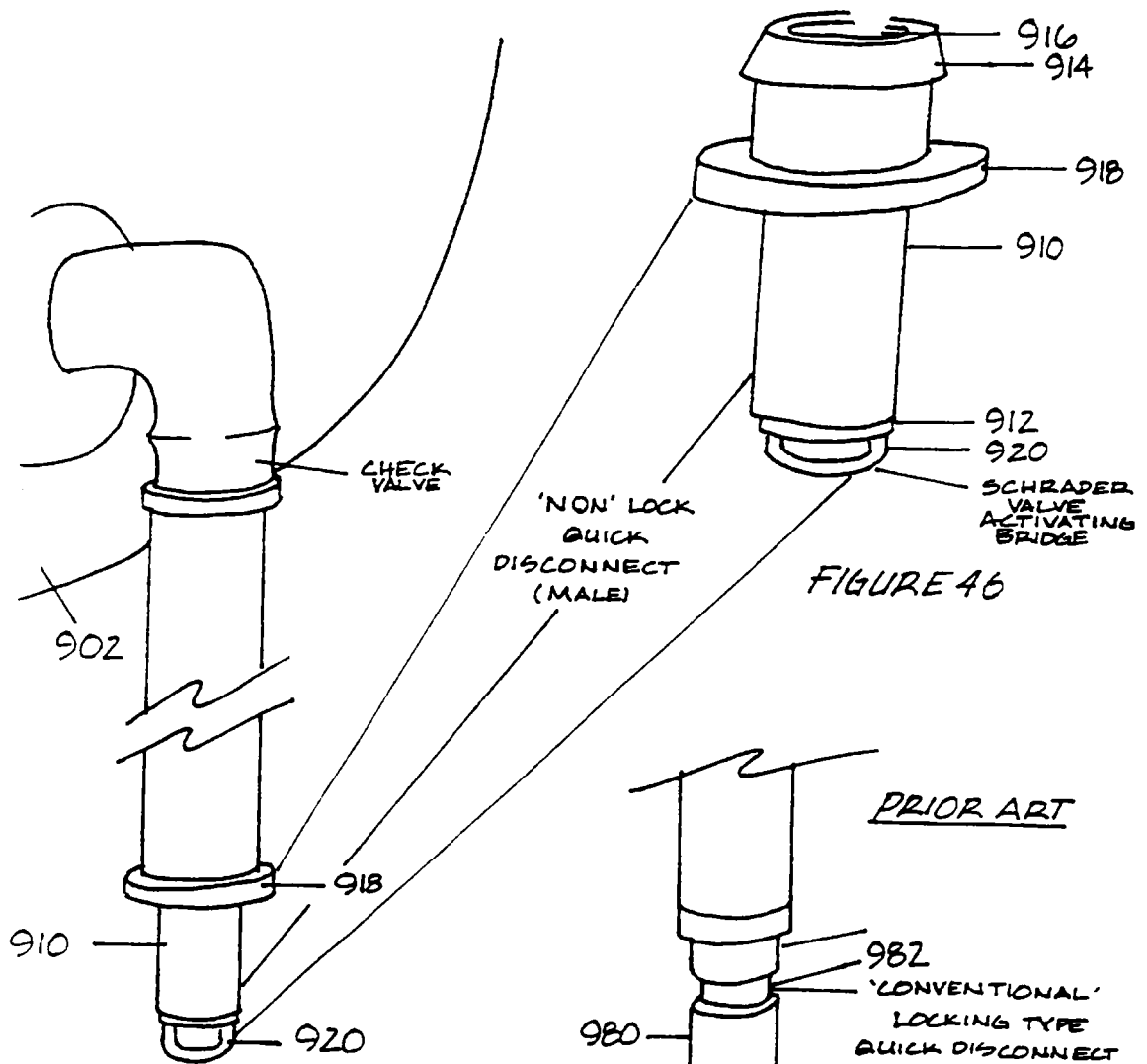

FIGURE 44



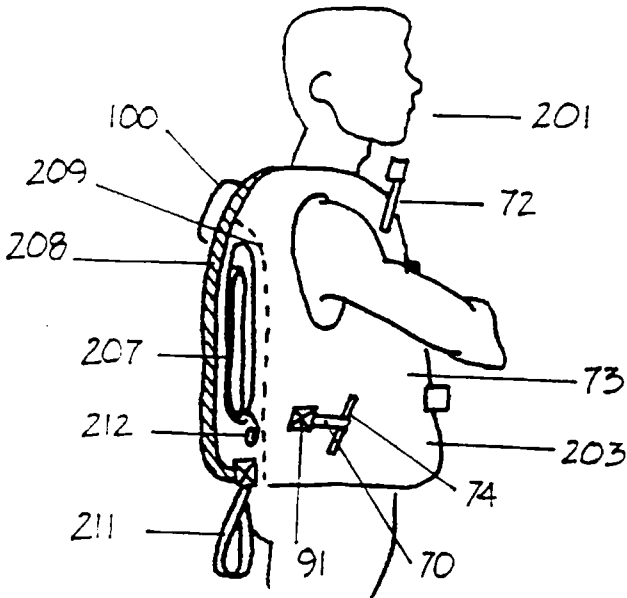

FIGURE 48

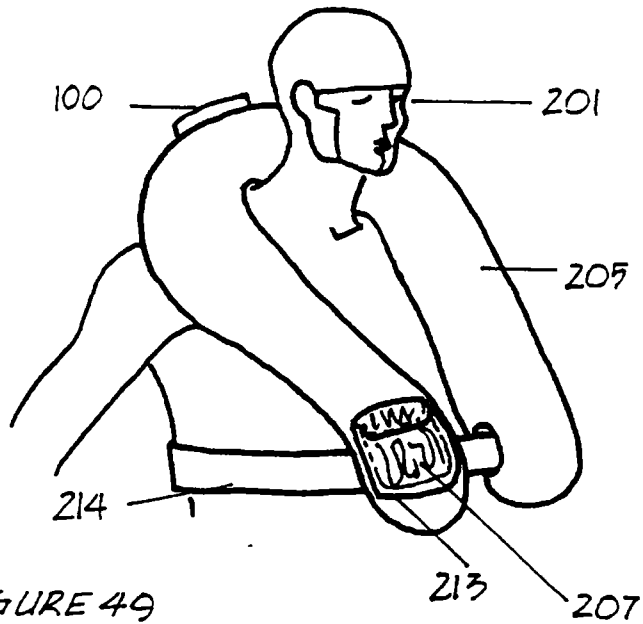

FIGURE 49

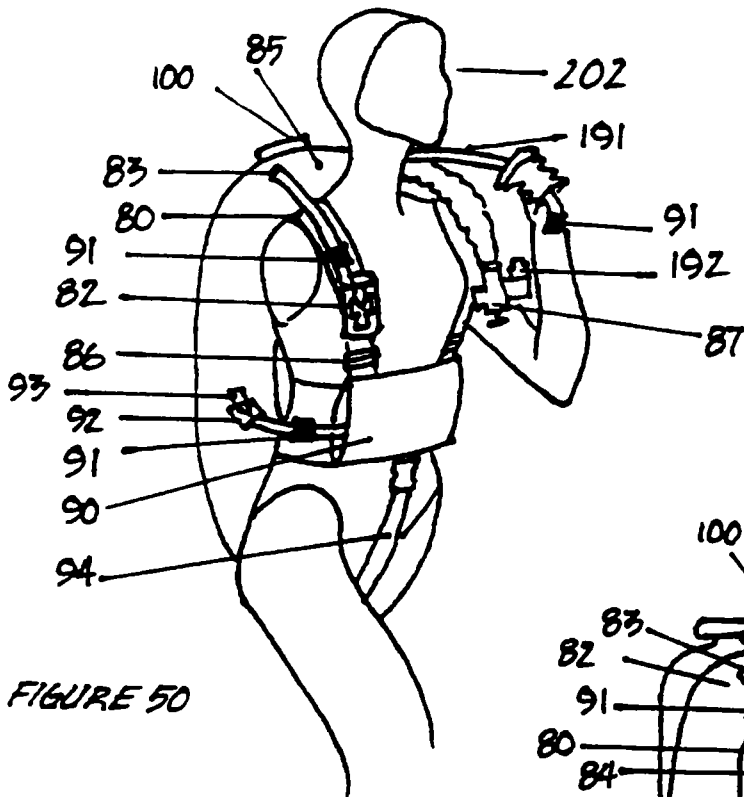

FIGURE 50

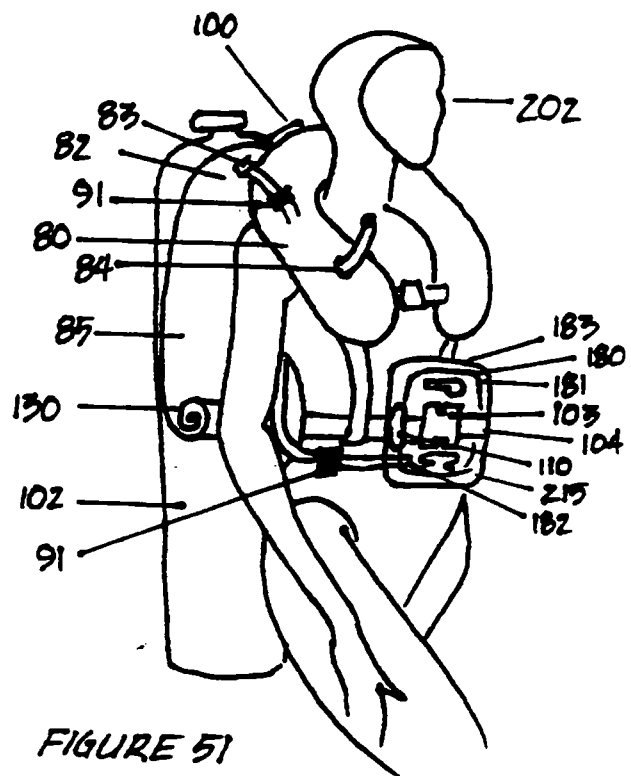

FIGURE 51

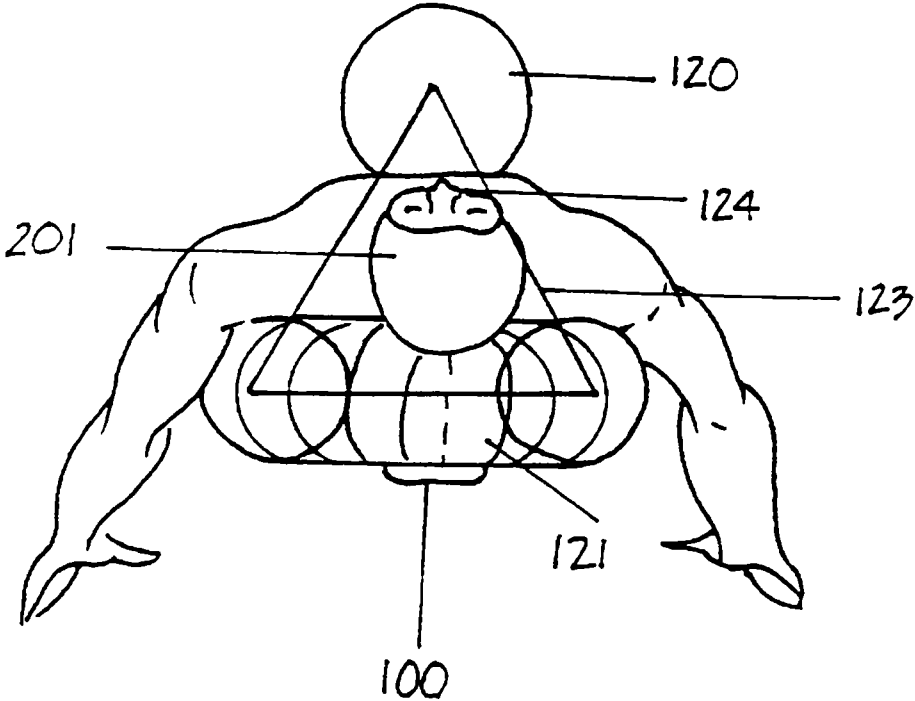

FIGURE 52

5.855.454

1

WATER SAFETY AND SURVIVAL SYSTEM

BACKGROUND OF THE INVENTION

This application is a continuation-in-part of U.S. patent application Ser. No. 08/149,137, filed Nov. 8, 1993, now U.S. Pat. No. 5,516,233, which is a continuation of U.S. patent application Ser. No. 07/870,244, filed Apr. 17, 1992, now abandoned.

1. Field of the Invention

The present invention relates to water safety gear including life vests, integrated rescue products, and hypothermic protective gear, adapted for one-time use by the victim placed in the water by accident or for regular use by the water enthusiast whether a sailor or scuba diver.

2. Description of the Prior Art

Heretofore, accidental immersion often resulted in death by two causes, aspiration leading to asphyxiation or hypothermia. A life saving system, to be viable for more than a few minutes, must successfully address both of these issues. Current life vests supply the requisite amount of buoyancy to return the victim to the surface, but often require a conscious victim's involvement to keep the airway clear. While it is common practice, as well as legally mandated, that all civilian, commercial, and non-civilian vessels carry Coast Guard approved life vests, many current water safety products provide only a limited portion of the safety they are capable of providing. They do provide for positive buoyancy during the shock of the initial entry into the water, but by incorporation of the concepts disclosed herein are capable of providing significantly improved airway protection after the initial insult with significantly increased reliability of airway protection and less bulk, cost and, consequently, more compliance.

By force of habit, life vests are currently designed after clothing and as such they open in the middle of the chest, producing a point of reduced buoyancy where it is least acceptable. The division of the forward chamber into two halves produces two side chambers which are each capable of generating righting moments in the water. When a righting moment is created on the body of an exhausted or unconscious individual, they can be stabilized in a face down or side down position. If the left or right side is out of the water, concurrent loss of muscle tone in the neck allows the face, nose, and mouth to be positioned underwater. Thus, current constructions of many life vest are really only adequate for conscious, alert, and active victims because they require participation, constant monitoring and adjustment by the user to keep the face and airway out of the water.

On sudden entry into the water, water on face actuates the Dive Reflex, which is a rapid uncontrollable inhalation. This reflex often results in aspirating water with its consequent choking and coughing. This distress further complicates the victim's ability to right themselves and assist in their own rescue. It is often the case that the sailor who is knocked overboard by the boom of the sail or is swept overboard by a wave, can suffer a temporary loss of consciousness. During this initial interval it is important that their life vest not only buoy them to the surface, but that it also obtain and maintain the victim's face and airway out of the water until consciousness is regained.

The only life vest that is of any value is the life vest that is worn. Compliance can not be ignored as an important criteria in the design and manufacture of any safety product. The actual use of safety vests has begun to move forward by the hybrid personal flotation devices. The HPFD is a com-

2

ination of a certain amount of inherently buoyant material along with an additional amount of inflatable buoyancy. Because of the reduced amount of bulk and therefore increased convenience associated with the hpfd, their acceptance is growing. U.S. Pat. No. 4,681,552 issued Jul. 21, 1987 to William Courtney, addresses the value of hybrid personal flotation devices. Like many vest style safety products and in particular all buoyancy compensators, the BC vest described in U.S. Pat. No. 4,681,552, when both chambers are inflated in the configuration disclosed in FIG. 1, would stabilize the user on their side, placing their airway underwater if the user was unable to hold their head up.

The vest that is constructed entirely from inflatable chambers is much more comfortable, convenient and therefore is frequently worn by itself and is now approved by the United States Coast Guard. The purely inflatable product such as the inflatable sailing harness, wind breaker, safety device, because of its compactness, is often the actual product worn by the victim. Many purely inflatable safety products attempt to compensate for the lack of inherent buoyancy by generating large amounts of lift. The use of excessive lift often results in the use of air under the arms where it creates the side up righting moment that can jeopardize the airway, a design defect addressed by the instant invention.

The airlines, because of their insoluble stowage problems are allowed the use of a purely inflatable device that has redundant chambers to guard against the failure problems inherent in single chamber safety devices. The scuba diver also wears a purely inflatable device known as a buoyancy compensator or "BC," which looks like a traditional life vest but because it lacks at least reliability is not called such. The sailor is known to use inflatable wind breakers. All these devices, as well as many not described here, that are meant to provide surface flotation to individuals in the water, would be markedly improved by incorporation of the concepts described herein. Whether constructed solely from inherently buoyant means as are traditional life vests, or constructed from a hybrid composition of inherently buoyant and partially inflatable, or constructed from purely inflatable components, the specific location of a minimal amount of ballast in accordance with the construction herein disclosed would confer dramatic improvements in bulk, cost and compliance and consequently, in safety and survival statistics at sea.

The prior art on the use of dual chambered safety vests includes Swedish patent #203592 issued to Lindqvist on Apr. 1966. This patent discloses a dual chambered product with a large forward chamber which would allow the victim to be stabilized in either a heads up position or if unconscious the victim could be stabilized lying over the forward float with their nose and mouth underwater. The device also relies on the victim's legs to apply tension to a draw string to pull the rear chamber up behind the victim's neck. For the active participant the product may have some utility but would be unsuccessful if not closely regulated. In addition the product is needlessly large and thus unnecessarily bulky when deflated, a feature that often results in the product being stored in a locker rather than being worn.

The buoyancy compensator is a convenience product that has unfortunately replaced the diver's safety vest. The buoyancy compensator is a specific adaptation of a purely inflatable safety product that is worn by the diver for use both at the surface and underwater. The product evolved from the orally inflated safety vest that had the appearance of and was often called a horse collar vest. After decades of diving it was decided that the diver would benefit from the inclusion of a chamber to hold air while ~~underwater~~ ^{submerged} to offset

the loss of buoyancy that occurs as the diver's thermal protective gear is compressed at depth. The initial compensators for this shift in buoyancy were containers that could be filled with air to displace water and therefore generate increased buoyancy as the diver's wet suit was compressed by the water. In an emergency this device could be easily disconnected from the diver.

The next step in the evolution of the buoyancy compensator was to use the air cylinder to inflate the safety vest, a product designed to protect the airway at the surface. Its proximity to the face and neck, its obstruction of the chest and therefore the site of controls for the dry suit diver, its general bulk and appearance left room for the advent of the life vest style buoyancy compensator. The initial detached, canister buoyancy compensators were of low volume and easy to ditch. The horse collar and then the life vest style buoyancy compensator became voluminous. The larger lift capacity became equivalent to the better product. Buoyancy compensators are available with 80 lb. lift capacities. At the surface the high lift product conferred a sense of security because it would buoy the diver far above the water as long as diver remained in firm control of the product. As the diving population became more diverse in health and age, the false sense of security led to marked competitiveness over the amount of lift that could be attached to the diver. The product is so confused with security that a diver can not get onto a dive boat without wearing a high lift buoyancy compensator for "safety" reasons.

The inflatable products worn by scuba divers as disclosed in Greenwood's U.S. Pat. No. 3,436,777; Robert's U.S. Pat. No. 3,747,140; Walters' U.S. Pat. No. 4,016,616; Wright III's U.S. Pat. No. 4,137,585; Scott's U.S. Pat. No. 4,176,418; Maness's U.S. Pat. No. 4,324,234; or Courtney's U.S. Pat. Nos. 4,645,465 and 4,681,552, and all buoyancy compensators in the prior art are complicated by the attachment of an air cylinder that undergoes shifts in buoyancy throughout each dive as the cylinder empties and becomes more buoyant. The size of the shift in buoyancy is directly proportional to the size of the cylinder used. The nature of the shift in buoyancy, whether the cylinder ends up positively buoyant or only less negative, is a combination of cylinder composition, most commonly aluminum or steel and the water density, fresh, brackish or salt. Some air cylinders become six pounds positively buoyant when empty in sea water. This cylinder will float on its longitudinal axis as will the diver who is attached to that cylinder. Consequently, if for any reason the diver is unconscious, such as from a minor embolism from rapid ascent, blackout, trauma, medical problem or just over exhausted after being stranded at sea, they will eventually lie along side the air cylinder with their airway under the water and statistically the deaths are recorded as drowning. The current management of the life threatening side righting moments of every vest style buoyancy compensator is to disclaim liability for keeping the airway out of the water.

The instant invention discloses the integration of a very small amount of non-releasable weight exactly opposite the diver that converts the only inflatable worn by divers into a product that will protect the airway if the diver is unable to. The attachment of weight to the air cylinder in the prior art has been a way for carrying the ballast necessary for the diver to be able to submerge, and thus were designed to carry significant amounts of weight. Patents issued have turned on the design of the release system. The dive community demands that the attachment of significant amounts of weight must be able to be quickly released by one hand, by either hand. The release mechanism must be sure in that it

must not accidentally release, but once the diver chooses to release the ballast the mechanism must be simple enough that it will not fail. All of the prior art by way of its incorporation of reliable release mechanism assures the diver that as an emergency is evolving and their weights are dropped to gain a better surface attitude, the air cylinder that was critical for use under water and is now empty will be attempting to float the diver on their side. If the diver is unable to oppose this action, their nose and mouth will be forcefully submerged.

It is to be noted that in U.S. Pat. No. 4,455,718, the quick release means is positioned centrally to allow access by either hand in the event of an emergency release. Prior to the release, the central positioning of the quick release mechanism necessitates that the weights as demonstrated in FIGS. 1 and 2 and be placed off center, potentially reenforcing the side righting moments of the life vest style buoyancy compensator. The keel retaining system disclosed is built into the buoyancy compensator so it will not be lost or left at home, the buoyancy compensator cannot be safely used without this critical component. In patent U.S. Pat. No. 3,670,509 it is noted that the ballast is located in front of the tank, close to the back of the diver and consequently closer to the axis of rotation which parallels the spine of the diver, thereby drastically reducing the rotational energy generated per unit of keel weight. This greatly reduces the effective strength of the angular rotation generated by a particular amount of ballast. Since some divers in the tropics may dive with only a few pounds of weight, it is important that the keel weight be kept as far away from the axis of rotation as is possible to maximize the strength of the righting moment. The critical location is on the exact opposite side of the tank from the diver. U.S. Pat. No. 3,670,509 refers to "substantial reducing" the tendency to force the diver face into the water. Use of the disclosed improvements will not allow the face to remain underwater. The ballast in patent U.S. Pat. No. 3,670,509 that attempts to reduce the face down righting moment, positions the diver so that they are able to "... activate the weight release mechanism.", with the loss of the ballast the diver then would be back to floating on their side with their airway underwater. U.S. Pat. No. 3,967,459 locates the weight system inferior and adjacent to the diver nearly the exact opposite as disclosed herein. It is also noted that this weight system is intended to be released in an emergency reestablishing the tendency of the cylinder to submerge the diver's airway. The integrated ballast system of U.S. Pat. No. 4,752,263 is similar in that it is releasable, and located inferior and adjacent to the diver allowing for an airway endangering surface position. The ballast system disclosed in U.S. Pat. No. 2,120,420 places weight symmetrically about the diver which would totally eliminate any heads up righting moment and in fact would stabilize the diver 50% of the time in a face down position, additionally, this system is not designed to be used with an air cylinder, but rather a surface supply air system.

The instant invention achieves many critical features including providing that the weight be permanently attached, so that in an emergency it cannot be dropped. Since the keel weight must be small enough to not compromise surface safety, it must be located on the cylinder exactly opposite the diver where it generates the maximal rotational energy per pound of keel, rotational energy desperately needed to repeatedly turn the unconscious diver over onto their back against minor righting moments caused by limbs, variations in body density, and attached gear. In particular, if the victim dives near heavy surf where the waves can flip a victim over onto their face, a strong heads up righting moment is essential.

EXHIBIT A
Page 211 of 240 pages

5.855.454

5

Another critical problem with the use of all current buoyancy compensators is that they combine high lift surface flotation needs with low lift underwater buoyancy needs. That same device at depth entraps pressurized air by design. The 190 lb. diver at 120 feet underwater requires nine pounds of air in their buoyancy compensator due to compression of their cold water wet suit. should that diver begin an uncontrolled ascent because; their regulator malfunctions, their tank is empty, they lose their mask and become disoriented, the power inflator sticks on their buoyancy compensators, they suffer a minor medical problems as they attempt an emergency ascent, for whatever the reason, as the diver ascends, the air in their buoyancy compensator begins to expand. Ten pounds of air at 99 feet underwater, increases to 13.3 pounds at 66 feet and increases to twenty pounds at 33 feet and doubles forty pounds during the last 33 feet of the water column, enough air to create excessively fast ascent rates.

Recommended safe ascent rates are in the process of being reduced from 60 feet per minute to 20-30 feet per minute. A buoyancy compensator that can contain 30 lbs. of air can accelerate a diver who is stationary less than 10 feet underwater to the surface at average velocities over the last 4 feet, in excess of 200 to 250 feet per minute. Ascent rates from greater depths or ascent rates with larger buoyancy compensators such as currently available products generating 40, 60 or 80 lbs. of lift are unknown. It is known that if a person's lungs are fully inflated and they hold their breath while ascending three and a half (3½) or four (4) feet, their lungs will rupture. Pulmonary barotrauma introduces air into the circulation where it can obstruct circulation and result in infarction of the tissue involved. Since the diver is often vertical during an uncontrolled rapid ascent, the embolism most often travels to the brain. Unless the diver is re-compressed within minutes damage is permanent and possibly fatal. The prior art on buoyancy compensators, as is practiced in the diving community, unfortunately combines low lift buoyancy compensation needs with high lift surface flotation. The prior art buoyancy compensator is in desperate need of the many advances disclosed herein.

Once the conscious or unconscious individual is supported safely at the surface with their airway free and clear, the next major threat to the water borne victim whether recently returned from the depths or a survivor of a common carrier accident such as an airplane crash, is from; not being seen by search and rescue efforts, of being drowned while attempting a rescue or from hypothermia.

The rapid lowering of the body's core temperature results in interruption of life sustaining cognitive activities such as staying in a tucked fetal position, which further aggravates heat loss. With the loss of cognition the victim stops monitoring and responding to changing surface conditions. Inevitably hypothermia interferes in brain stem activities such as musculoskeletal tone and respiration. It is widely known that hypothermia is the actual killer in most accidental immersions. In response to such knowledge, exposure suits have been developed to insulate individuals and preserve core temperature thus extending survival from minutes to hours. An effective exposure suit is a large, bulky item that is prohibitively expensive. Despite these serious drawbacks it is the only alternative to dying from hypothermia within minutes and as such it is a legally mandated safety device for the industrial sector where its costs, bulk and inconveniences can be borne. Exposure suit costs and bulk have prevented their use being required in the recreational, civilian or commercial carrier sectors such as airlines, liners, ferries etc. Therefore it is clear that despite recognition that

6

hypothermia is the active process in death at sea, there has not existed until this time a viable, affordable, storable means to control hypothermia.

To address this deficiency in the prior art, the current invention addresses both aspects of safety at sea. Rescue can rarely be performed within minutes. Often the sailor on watch is not missed until the next watch, obviously the single handed sailor is never missed. The sinking of a civilian or commercial carrier is often unattended for many hours or longer. As is noted in Harrigan's U.S. Pat. No. 2,114,301; Bennett's U.S. Pat. No. 3,105,981; or DeSimone's U.S. Pat. No. 4,187,570, there exists complex, bulky and costly means whereby jet pilots and navy personnel have personal power inflated life rafts. These automatically inflated life rafts require a cylinder whose cost alone is prohibitive to private and commercial carriers. The bulk of the cylinder, the bulk of the raft constructed from a fabric capable of withstanding pressurized inflation and high impact forces results in a device that is incompatible with civilian and commercial carriers such as airlines or ferries, yet alone individuals wind surfing, fishing from rubber rafts or touring ocean kayaks.

SUMMARY OF THE INVENTION

The smallest safety vest that reliably protects the victim's airway is ideal because of its lower cost, reduced bulk when deflated, and improved appearance, all factors that contribute to compliance with use, the true basis of success in any emergency. The current water safety vest distinguishes the two critical points of buoyancy, one behind the neck and head with the second point of buoyancy being in the area of the umbilicus, and one of ballast, behind the victim and their flotation chamber. A very small amount of buoyancy and ballast securely attached to the victim at these two points is sufficient to roll an individual over and put them on their back, thereby protecting their airway from submersion. Entry and adjustments are from below, from the side or if from the front then the front chamber must overlap and be maintained and secured in a central position. Only this combination of small buoyant chambers reliably creates safe positioning of the victim's neck and head. This face up righting moment is generated regardless of the angle of entry into the water or level of conscious participation. This strong righting moment also compensates for the ongoing effects of rotational forces such as waves that at a certain point will overcome the lateral stabilization provided by the rear perimeter chamber.

Ideally the rear chamber is constructed to cradle the head and neck preventing it from drooping over backwards or sideways and becoming submerged. The chamber can be extended along the sides where they act much as outriggers, stabilizing the body from being rolled over because of wave action. The perimeter rear buoyant chamber defines a space, and actually forms a containment means for stowing a separating flotation chamber, such as a multi-function rescue safety product. It also is the ideal site of expansion that occurs when an inflatable life vest is actually inflated. All inflatable buoyant chambers upon inflation convert from a two dimensional product to a space occupying three dimensional object. This creates a shortening that results in constriction. Power inflated vests generally have an over pressure valve to protect against rupture but before this is actuated an unacceptable amount of pressure is applied to the thorax of the wearer. To compensate for this either the garment is very loose so that when it is inflated the wearer can still breathe or the chamber slides along a retaining strap or belt shifting the position of the inflatable bladder and

5.855.454

7

thereby shifting the righting moment. Current inflatable vests upon inflation slide to the rear as an accommodation to the front entry. This pulls the buoyant means towards the back and results in greater moments of stability in the side high position which submerges the airway. In the current embodiment if the vest is entered from the front its closure is fixed. The rear buoyant chamber upon inflation stretches away from the center of the back and out towards the sides strengthening the lateral stability of the vest and the forward central buoyant bubble remains aligned along the center.

There are several reasons that most life jackets are vest style; the historical basis of clothing design, the need to locate the required amount of lift required by the regulatory agencies and the degree of fit. The buoyancy generated by the life vest must be able to be secured reliably about the torso of the wearer. Entry into the water or rough surface action must not strip the life jacket from the victim. In this regard the secure closure, appropriate sizing and an elastic component combine to provide a reasonable attachment. The only way to be assured that the victim and their life jacket will not be separated is by the inclusion of a crotch strap. Once again compliance is a function of comfort. If the crotch strap is loosely attached prior to entry into the water then easily adjustable while in the water, it might be used. A wet, limp, unconscious victim being tossed about by waves will require a retaining strap between the legs to optimize the survival value of any buoyant product attached to the victim. Its inclusion in a life saving system is necessary, the option of its timely use is a function of comfort and cosmetics. Another reason for the current vest design of water safety products is that the Coast Guard use to require certain amounts of buoyant lift for varying classes. Commercial requirements exceed those for personal use, but all classes displace such a large volume of water that the buoyant means needs to be spread out over a large surface area such as is provided by a vest style life jacket configuration, despite its serious drawbacks.

Some vest style life jackets have four righting moments; face up, back up, left side up and right side up. The current invention creates a broad base triangle. Central to this invention's uniqueness is a small buoyant bubble that is centrally located in front of the wearer, and a small amount of ballast posterior. The front chamber is responsible for initiating the righting moment and the counterweight eliminates the side position, and supplies the rotational energy needed to roll the victim over onto their back thereby assuring that the victim's face will be out of the water regardless of the angle of entry. Once the forward chamber has reached the surface, it in conjunction with the dynamics of a limp unconscious body, will oppose any tendency for the waves to roll the victim over into a face down position that would compromise the airway. If the front chamber is too wide, it can combine with the rear buoyant bladder and create a second, life threatening righting moment in which either side could be held at the surface and concomitantly the airway submerged. In summary, the rear buoyant chamber provides a base of support for the head and neck, supporting the airway and providing lateral stabilization, opposing rotational motion of the waves from over turning the victim into a face down position, but in the event that occurs, the forward buoyant bubble that is located at the umbilicus will automatically flip the victim back over onto their back, reestablishing the heads up orientation.

While the forward and rear buoyant chambers could be constructed from a single chamber, ideally two or more chambers confer several advantages. In this design one of the chambers is retained by a releasible system. This feature

8

allows the wearer the option of being able to remove a chamber and use it as a distress marker, thus the preferred embodiment is to construct the forward chamber from a highly visible and radar reflective material. Separation also allows the chamber to be used as a rescue device. It can function as a rescue board to approach a swimmer in distress or used as a buoyant assist beneath the arms of the rescuer to provide lift in the event the rescuer is attempting to perform artificial respiration while in the water.

In adapting the product for the scuba diver, the separating chamber can be used under water by the advanced diver to mark a dive site such as in search and rescue attempts. The separating bladder can also be used as an underwater lift or salvage device rather than the common but unsafe practice of using the divers high lift buoyancy compensator as a salvage device. In the event that the object being salvaged slips from the divers grasp, the diver suddenly becomes markedly buoyant and is thrown into an uncontrolled ascent. In the event of a sudden increase in boat activity the diver could leave the separating chamber at the surface marking the dive site, so that boaters will avoid driving over the partially submerged diver. The universal retaining strap of the releasible chamber ideally has an elastic component to allow for distention of the bladder when it is inflated. The separating chamber when modified for use underwater in a buoyancy compensator must be reliably regulated. Safe and secure containment of the bladder underwater is critical. As helpful as additional buoyancy is at the surface, that same buoyancy underwater represents serious exposure to rapid ascent with its numerous serious problems. On the other hand the surface flotation chamber must also be simply and quickly deployed to be of assistance of an emergency at the surface.

Because the volume of the buoyancy compensator has been reduced to mitigate the chances of rapid ascent, it is foreseeable that the forward surface flotation chamber may not be deployed in an acute emergency underwater so the rear chamber and the disclosed keel weight have to be sufficient to protect the airway by establishing a heads up orientation with or without the deployment of the forward chamber.

When an air cylinder is attached to the heads up life vest, the life vests counterweight must increase in size to offset any additional outrigger effect. It is called a keel, because when the diver is lying face down at the surface and goes limp, the tank compensating keel weight, like the keel of the sail boat will roll the diver over onto their back, stabilizing the airway out of the water. The compensating portion of the name is because the size of the weight is in proportion to the type and size of the vest, cylinder and whether the water is fresh or salt. If the cylinder when empty is neutral to slightly negative it will sink allowing the diver to roll over onto their back. The keel weight in other words compensates for the buoyancy shifts of the diver's jacket and air cylinder. If the cylinder remains negative when empty then the keel weight can be smaller but still must generate sufficient angular momentum to offset the secondary righting moments generated by an imbalanced weight belt and attached gear or bladders. If the keel weight is used as an adaption to existing vest style buoyancy compensator, then it has to be strong enough to overcome the side righting movements generated by the common practice of using buoyancy under the arms.

Central to the tank compensating keel weight's design is that it be made of a very dense material such as lead, and be located exactly opposite the diver on the back side of the tank. Traditionally the buckle that generates pressure on the belt that attaches the buoyancy compensator to the tank is

EXHIBIT A
Page 24 of 114 pages

5.855.454

9

located in the center at the back of the tank. Because the posterior central position is so critical for the performance of the keel, the buckle has to be moved off center. This shift in the cam buckles location results in a slight inconvenience in terms of reduced access but is necessary to preserve the critical location and therefore the righting moment of the compensating keel weight.

Ninety (90%) percent of drowned divers are often found with their weight belts still on and fifty (50%) percent of such are at the surface. Usually the weights are located along the waist and the amount runs from a couple of pounds to more than forty pounds. As the amount of weight increases, the keel weight needs to be located higher up the air cylinder to offset the placement of the weight belt. The dual tank band allows for a wide variation of weight placement. Obviously, the keel weight could be incorporated into the metal of the cylinder, adhered to the cylinder, enclosed in a covering of any sort, or even attached with magnetism. A pouch or cylinder could be used to contain lead shot or beach sand as long as it is located along the longitudinal axis of the cylinder and thereby serves to generate the heads up righting moment.

Additionally the concept of critical ballast is such that a certain amount of ballast is absolutely required in order for the diver to stay underwater. To facilitate the concept of safe diver weighting the tank compensating keel weight is also used to offset the inherent buoyant material from which the buoyancy compensator itself is constructed. Thus, because of the tank compensating keel weight, the buoyancy compensator, the tank, and regulator combination is neutral and as such does not contribute to the consolidation of additional ballast on the weight belt. If the quick release buckle of a consolidated weight belt should snag on a plant or slip out of hand during adjustment at depth the dangers of an uncontrolled buoyant ascent are somewhat mitigated because the shift in buoyancy is reduced by the amount of ballast used as a tank compensating keel weight.

While the forward chamber is not critical for protecting the airway of the scuba diver because of the effectiveness of the tank compensating keel weight, the forward chamber's ability to provide additional high lift surface flotation fulfills an expectation in the sport. The key to the addition of high lift surface flotation to the diver underwater is its safe regulation. The operation of the forward chamber requires diametric opposed properties of the valve chosen to regulate the chamber. One embodiment employs the use of a variable fabric valve fabricated from a self releasible hook and loop fastener such as VELCRO® that can operate in three different modes, as a manual on/off valve, semi-automatic valve or a fully automatic valve. In addition, as the fabric valve ages its strength can be renewed by further increasing the interactive surface area.

The value of including a variable valve in line between the rear chamber and the forward chamber is that the diver can become more responsible with experience and training for the total amount of lift available to the diver underwater as well as at the surface and thus more responsible for uncontrolled ascent rates and consequently the risk of pulmonary barotrauma, arterial gas embolism and its frequent outcome cerebral infarction as well as the risks of decompression sickness.

Some dive instructors fear that the beginning student will not be able to perform an additional task in an emergency and therefore prefer that the entire buoyancy system automatically inflate choosing simplicity of operation at the expense of exposing the beginning diver to the conse-

10

quences of a more rapid uncontrolled ascent, despite the fact that deaths have occurred during buoyant ascents while training in a swimming pool. In particular, since the student will be involved in a lot of surface drills and exercises, such as determining how much weight they require in order to be able to submerge, clearing their masks and snorkels, and since the first dives will be shallow, the consequences of rapid ascent are severe. As their experience grows and their comfort in the water with their gear and the concepts of correct weighting develop, they will be making deeper dives where the consequences of sudden ascent continue to mount and become progressively more severe. As the student begins to submerge and the lungs become more pressurized the manual operation mode of the valve is necessary for the diver to safely regulate the total amount of lift attached to their body underwater and thereby mitigate one of the major risks of diving.

As the buoyancy compensator is reduced to a device dedicated to contain the small amounts of lift actually required while underwater, some instructors are concerned that the diver will not be able to rely on the buoyancy compensator for a buoyant ascent. The problem with buoyant ascents is that they are very difficult to control when all the divers' faculties are intact. In an emergency the ability to regulate a high lift buoyancy compensator at depth is very unlikely. Optionally, one of the forward chambers can be a low volume chamber designed for emergency ascent which has incorporated a rupture plug, disc or weld so that if the product is deployed unintentionally by use of a CO2 cylinder or the divers air cylinder, or accidentally, it will self destruct at a preset pressure differential, limiting its buoyant assist to the first leg of an emergency ascent allowing the diver a second chance to regain control and reduce their velocity to a safe rate. Some of the larger high lift surface flotation chambers may never fill to rupture so its containment system that regulates its inflation must be very secure to be assured that it will only be deployed intentionally, otherwise the diver would be in the same high lift rapid ascent predicament that they currently find themselves in with today's product.

Incorporated within the multi-chambered heads up safety vest is a multi-function rescue safety product which can culminate into a raft for removal of the victim from the water and thereby confer protection from hypothermia. The needs and use of this rescue safety product determines its requirements for durability which in turn determines the type of fabric, its storable volume and therefore the location of the rescue product within the safety vest. The primary flotation device or life vest stays secured to the individual to assist them during their entry, and support them while they are deploying the rescue product. Once inflated if the product is not needed for rescue or signaling, the rescue product evolves into a raft that the individual can crawl into. The life vest remains on the victim protecting the individual should they be washed overboard as well as insulating the trunk, further helping to maintain core temperature.

The need and uses of a rescue device varies with the application. For the civilian airline passenger suddenly thrust into a survival situation, they are provided with a floating cushion or a lightweight inflatable life vest. In this situation a single use, ultra lightweight product is ideal. Such a rescue product might be constructed from an all welded mylar film. A multiplicity of layers would confer separate air chambers within the product providing for insulation, conferring a puncture protection while remaining small enough to fit inside a seat cushion or within a pocket of a purely inflatable life vest. To facilitate the single use products

EXHIBIT
A
Page 38 of 167 pages

operation the oral inflator would lead to a manifold which could be constructed of differing diameters and/or which would pass through separate one way check valves of differing relief pressures. The diameter and/or pressure relief valves would direct the flow of air such that the chambers could be inflated sequentially. As pressure in the system builds up after inflating the first air chamber the second begins to inflate. The arrangement would allow for the inflation of a life ring first, followed by the rescue float, then if necessary a large outer tube would convert the rescue product into a raft with a canopy arch. The mylar, in addition to reflecting the radiant energy back towards the victim, is mirrored so that it is highly visible and radar reflective both of which would facilitate search and rescue. It structurally would resemble a single use raincoat. With the advantages conferred by this invention the victim could be of assistance to themselves and to others. Survival would be increased from minutes to days, dehydration would become the next serious threat to the survivor. An off the shelf plastic solar still could be easily included for trans-oceanic passages.

The water enthusiast on the other hand may find themselves in the water more often than the civilian airline passenger and their needs may tolerate slightly more bulk from the stored rescue product in exchange for reusability. The bulk increases because of the demands of a more durable and reusable product requires a more substantial choice of fabric. As the bulk increases, the location for stowing the rescue product becomes more critical. The ideal location is built into the back of the life vest where it is out of the way but securely and accessibly stowed until needed. In this posterior and inferior position the actions of the new and improved life vest are retained, that is the perimeter of the torso is supported by the rear inflation chamber of the life vest, stabilizing the victim against inadvertent rotation to a face down position. The location of the raft, is ideally within the walls of the life vest, protecting the raft from the shearing forces of entry, freeing the hands to assist entry and recovery once in the water. An envelope for containing the rescue product could be provided so that it could be attached to the inside or outside of any current life vest and thereby confer the protective advantages to all owners of a life vest without having to incur the cost of buying a new life vest. This would allow all current owners of a safety vest to upgrade to a dual chambered separating water survival system. This attachment system employs a hook and loop fastener looped through the arm holes and is universally adaptable to all life vests, of all sizes. Any releasable fastener such as buttons, zippers, snaps, hook and loop, etc. would allow for the rescue product and its stowage and release system to be located comfortably centered both up and down as well as side to side. While it could be positioned outside the life vest, its inclusion within the life vest will ensure its secure attachment. The inflation of the rescue product is determined by its use, cost, and available stowage space but since oral inflation is not restricted by shelf life, it is always present and most affordable. Inflation via a manifold will allow the rescuer to provide a rapidly inflated life ring to help stabilize the victim through the initial insult and then provide a float while the remainder of the chambers are inflated. In the current embodiment the rescue product is built into the safety vest or floating cushion, if anyone in the water intentionally or accidentally and is sequentially inflated through a series of rescue products that culminates in a raft for removal of the individual from the hypothermic effect of the water.

An additional advantage of the disclosed invention is directed to the adaption necessary when the safety vest is

used underwater by the scuba diver. In this application the heads up safety vest would be called a buoyancy compensator or BC. Because of the serious consequences of rapid ascent on pressurized lungs, in addition to the reliable regulation of the high lift surface flotation component of the buoyancy compensator, the primary buoyancy compensation bladder should be variable size. By design the buoyancy compensator is to be used underwater where it is vulnerable to inflation from entrapped pressurized air at two to three atmospheres, as well as subject to inflation from panicked misuse or mechanical failure of the power inflator, all causes leading to the same result, dangerously rapid ascent rates. The volume of the bladder should be tailored to the dive environment. The dedicated buoyancy compensator can be adjusted to the lowest volume needed to accomplish the goal of compensating for compression of thermal protective gear and the resultant loss of buoyancy. As the dive environment changes, so does the need for thermal protective gear. In tropical water minimal or no protective gear is worn and therefore the diver has nothing to compress and so experiences no loss of buoyancy at depth. For the diver in a bathing suit, the need for a power inflatable bladder underwater is limited to the shift in buoyancy that occurs in their air cylinders, and usually is well under 5 or 6 pounds of lift. This chamber is only needed to cover the initial overweighting needed to allow the diver to be neutral at the end of the dive in order to make a safety stop. This product should not be called a buoyancy compensator as a first step in reeducating the diving population about the dangers of power inflatables underwater.

In cold water, at 120 feet of depth, a 190 lb. diver in a 1/4 inch neoprene wet suit experiences a loss of 9 lbs. of lift due to compression of the wet suit. Most sport divers are smaller and therefore are wearing less neoprene, dive in warmer waters and/or making shallower dives. There is no justification for subjecting a diver to unnecessary risks of rapid ascent. Due to the extreme danger of pulmonary rupture and secondary air embolism that results from a rapid uncontrolled ascent it is imperative that the buoyancy compensation chamber be restricted to the lowest volume absolutely necessary to accomplish its goal. Any lift over and above the minimum amount exposes the diver to unnecessary risk. The diver doing repetitive dives in one day is advised to do their deepest dive of the day first and will need a buoyancy compensation capacity commensurate with their thermal protective gear and dive plan. As the dives become shallower and consequently warmer as well, the volume of an adjustable buoyancy compensator can be reduced, and consequently reduce the divers exposure to the risk of rapid ascent. Recommended ascent rates are dropping from 60 feet per minute to 20-30 feet per minute. The medical literature notes that a 30 lb. buoyancy compensator can produce average velocities in excess of 250 feet per minute from less than ten feet under the water. For several generations, divers dove without a buoyancy compensator so its use cannot be construed as critical. The advent of this convenience product has resulted in ballistic ascent rates because of the air entrapped inside the product which is pressurized at depth which then doubles and possibly quadruples upon ascent depending on the initial depth. An inexperienced diver in an "out-of-air" situation is prone to forget about the intellectual concept of arterial gas embolism in the hypoxic and hypercapnic driven race to the surface, only to die from an arterial gas embolism before ever getting a chance to drown. Drowning is a slow, reversible process that lends itself to rescue for quite some time after the event, unlike arterial gas embolism. When using an adjustable dedicated buoyancy

EXHIBIT A
Page 39 of 44 pages

5,855,454

13

compensator the diver can very precisely control their exposure to the dangers of an emergency ascent through the water column and thereby significantly reduce the risks of rupturing a lung and suffering an arterial gas embolism to the brain or heart or similarly reduce the risks of suffering the bends because of missed decompression stops.

An alternate location for a separating forward surface flotation chamber is for its inclusion within the shoulder straps. The redundant personal flotation device is designed to be separated away from the remainder of the dive gear to provide complete duplication of personal flotation devices in the event of failure of the primary chamber. The chamber can also be used as a rescue, signaling, salvage product or snorkeling vest.

Appropriately sized releasable shoulder trim weights offset the operation of the buoyancy compensator underwater, improving swimming position, decreasing frontal area, producing less hydrodynamic resistance and consequently less diver fatigue. Once again, the shoulder trim weight results in a reduction of the consolidated weight belt with its inherent advantage of protecting the diver from accidental loss of all ballast at one time.

In summary, a multiple chambered life vest can be of a low volume, low lift, and low profile design as long as at least two points in need of buoyancy are covered, behind the neck and at the umbilicus and one point of ballast along the vertical posterior axis. Excessive buoyancy can be extremely detrimental either because the product is not actually worn because it is too bulky or because side righting moments have been created that jeopardize the airway. The separating chamber in the hands of a conscious, capable user can be removed providing a signaling device for facilitating search and rescue efforts or used as a rescue board minimizing the risk associated with attempting to rescue another victim who has become hypoxic. After the initial insult has been survived the user can deploy the incorporated inflatable rescue product that sequentially inflates into a life ring, then rescue board and distress marker and culminates in a raft to remove the victim from the water with its inevitable and often rapid hypothermia. The entire water safety survival system constructed for a single use application could easily fit within the air line seat cushion, dramatically improving survival statistics for accidents at sea.

The multi-chambered heads up safety vest as adapted for the scuba diver allows for reliable segregation of a variety of high lift surface flotation chambers while underwater. In addition a variable volume dedicated buoyancy compensator allows the diver to further reduce the amount of lift attached to the smallest amount necessary for a particular dive environment. The combination of these two improvements will markedly reduce the largest cause of pulmonary barotrauma, and secondary embolism, a major cause of injury and death in the field of diving.

The inclusion of a couple of pounds of weight integrated into the posterior axis of the victim's vest will allow the victim to overcome numerous minor righting moments that can place the airway of the exhausted or distressed victim under the water leading to drowning another major cause of death in the sport of diving. The benefits of the tank compensating keel weight are so dramatic that they can be included into a separate product that can retrofit existing buoyancy compensators, converting them into a heads up product. The inclusion of the multi-function rescue product within the walls of the buoyancy compensator confers on that diver the ability to respond to a number of problems frequently encountered by the diver in rescue, marking and salvage.

14

In accordance with these and other objects which will become apparent hereinafter, the instant invention will now be described with particular reference to the accompanying drawings.

BRIEF DESCRIPTION OF THE DRAWINGS

FIG. 1 is a view of a personal flotation device shown incorporating the multi-function rescue product within the back wall of the vest.

FIG. 2 is a view of an existing buoyancy compensator with the multi-function rescue product attached.

FIG. 3 is a view of an airline life vest carrying a multi-function water rescue safety product.

FIG. 4 is a view of an airline seat cushion modified by the inclusion of an ultra lightweight disposable multi-function rescue safety product.

FIG. 5 is a view of an inflation manifold.

FIG. 6 is a top view of a multi-chambered rescue product.

FIG. 7 is a cross section view of the multi-function rescue product fully inflated.

FIG. 8 is a view of a face up personal flotation device modified for scuba diving.

FIG. 9 is a view of the scuba diver with an inflated separating horse collar, and self rupturing emergency ascent chamber.

FIG. 10 is a view of the inflatable cummerbund, with a releasable forward chamber, carrying an alternatively forward chamber in the form of a float.

FIG. 11 is a view of the pyramidal structure with central forward buoyant chamber and rear buoyant chamber.

FIG. 12 is a combined view of the elements of the water safety and survival system as it is adapted to the scuba diver.

FIG. 13 is a front view of the adjustable buoyancy compensator.

FIG. 14 is a rear view of an alternate adjustable buoyancy compensator.

FIG. 15 is a front perspective view of a first counter weight member in accordance with the present invention.

FIG. 16 is a back perspective view of the counter weight member illustrated in FIG. 15.

FIG. 17 is a front elevational view of the counter weight member illustrated in FIG. 15.

FIG. 18 is a back elevational view of the counter weight member illustrated in FIG. 15.

FIG. 19 is a side elevational view of the counter weight member illustrated in FIG. 15.

FIG. 20 is a top plan view of the counter weight member illustrated in FIG. 15.

FIG. 21 is a front perspective view illustrating a first attachment embodiment for a first counterweight assembly in accordance with the present invention.

FIG. 22 is a front perspective view illustrating a second attachment embodiment for a first counterweight assembly in accordance with the present invention.

FIG. 23 is a back perspective view illustrating the second attachment embodiment for the first counterweight assembly.

FIG. 24 is a perspective view illustrating a connection portion of a coupling strap in accordance with the present invention.

FIG. 25 is a front perspective view illustrating a second attachment embodiment for a first counterweight assembly in accordance with the present invention.

FIG. 26 is a top plan view of the counter weight member illustrated in FIG. 15 having at least one suction cup.

FIG. 27 is a side elevational view of the counter weight member illustrated in FIG. 15 having a plurality of suction cups.

FIG. 28 is a front elevational view of a second embodiment counterweight assembly in accordance with the present invention in a flap open position.

FIG. 29 is a top elevational view of the second embodiment counterweight assembly with the flap removed.

FIG. 30 is a front elevational view of the second embodiment counterweight assembly in a flap closed position.

FIG. 31 is a side elevational view of the second embodiment counterweight assembly.

FIG. 32 is a front elevational view of a third embodiment counterweight assembly in accordance with the present invention.

FIG. 33 is a side elevational view of a weight member utilized with the third embodiment counterweight assembly.

FIG. 34 is a perspective view of a fourth embodiment counterweight assembly in accordance with the present invention.

FIG. 35 is a top plan view of the fourth embodiment counterweight assembly.

FIG. 36 is a perspective view of a fourth embodiment counterweight assembly in accordance with the present invention.

FIG. 37 is a perspective view of a fifth embodiment counterweight assembly in accordance with the present invention.

FIG. 38a is a front elevational view of the fifth embodiment counterweight assembly.

FIG. 38b is a front elevational view of a soft weight member in accordance with the present invention.

FIG. 38c is a front elevational view of a hard weight member in accordance with the present invention.

FIGS. 39a through 39e illustrate the various steps which are performed for removing a pouch member and associated weight member from a pocket member for the fifth embodiment counterweight assembly of FIG. 37.

FIG. 40 is a front perspective view illustrating a combination of counterweight assemblies in accordance with the present invention utilized together.

FIG. 41 is a back perspective view illustrating a combination of counterweight assemblies in accordance with the present invention utilized together.

FIG. 42 is a perspective view of a diver having his or her airway submerged.

FIG. 43 is a perspective view of a diver having his or her airway protected in accordance with the present invention.

FIG. 44 is a perspective view of a training device for determining proper size and location for the weight member in accordance with the counterweight assemblies of the present invention.

FIG. 45 is a perspective view of a quick disconnect member in accordance with the present invention.

FIG. 46 is an enlarged perspective view of a male portion of the quick disconnect member illustrated in FIG. 45.

FIG. 47 is a perspective view of a prior art quick disconnect member having its female portion in section.

FIG. 48 is a view of the personal flotation device shown in Figure and incorporating a counterweight member.

FIG. 49 is a view of the airline life vest shown in FIG. 3 and incorporating a counterweight member.

FIG. 50 is a view of the face up personal flotation device shown in FIG. 8 and incorporating a counterweight member.

FIG. 51 is a view of the scuba diver with the inflated separating horse collar shown in FIG. 9 and incorporating a counterweight member.

FIG. 52 is a view of the pyramidal structure with central forward buoyant chamber and rear buoyant chamber shown in FIG. 11 and incorporating a counterweight member.

DESCRIPTION OF THE PREFERRED EMBODIMENTS

FIG. 1 shows victim 201 wearing a vest 203 that can function separately as a snorkeling vest, personal flotation device for boating or alternately hooked up to the primary bladder of a buoyancy compensator through quick release means 91 and hose 70 that is attached within pocket 74. Vest 203 can also be inflated through oral inflation means 72. Additionally, vest 203 can be incorporated with a ballast means 100 (FIG. 48). A multi-function rescue product and raft 207 is stowed within the back pocket of the lift vest between the outer wall 208 and inner wall 209. A retrieval strap 211 opens the pouch formed by wall 208 and wall 209, and is wrapped around raft 207 allowing the user to remove rescue product and raft 207, comprised of an expansible material allowing inflation chamber portion 73 located along the perimeter of the back to roll forward upon inflation.

FIG. 2 shows a diver 202 adapting an existing vest style buoyancy compensator 204 to carry the rescue product 207 within a containment pouch 210, held in place by band 23 that is supported by arm holes 24. A retrieval strap 211 is wrapped around rescue product 207 so that it can be removed from the containment pouch 210 without having to remove the vest 204. The scuba tank 102 is standard.

FIG. 3 shows a typical inflatable vest 205, as might be worn by an airline passenger 201, that is strapped to the victim by strap 214, in the event of a water landing. The typical vest 205 is modified by addition of a containment pocket 213 that stows a single use rescue product 207. Additionally, vest 205 can be modified by the addition of a counterweight 100 (FIG. 49).

FIG. 4 shows an airline cushion 206 containing rescue product 207. The victim puts their arms through straps 15 to secure the cushion 206 to the victim during water entry.

FIG. 5 shows a manifold device 17 that connects an oral inflator 16 through barbed fittings 18 to a series of one-way check valves that can also function as variable pressure relief valves 19, 29, 39, 39, and 59 that connect via tubing 20, 30, 40, 50, and 60 to a series of inflatable chambers as are demonstrated in the next drawing, FIG. 6.

FIG. 6 shows a multi-function rescue product and raft 207, comprised of life ring 21 which is inflated by tube 20 which because it has the largest diameter tubing and because the pressure relief valve 19 has the lowest relief pressure setting, will inflate first. Inflation chamber 31 or the floor is the second to inflate. Chamber 41 is a second chamber in the floor and because of the setting of the pressure relief valve and/or the diameter of tube 40 would be the third chamber to fill. The first three chambers; the life ring 21, and the floor chambers 31 and 41 form a rescue board or distress marker. The next chamber is a wall tube 51 and that can be inflated while resting on combined chambers 21, 31, and 41. The final chamber 61 forms an arch, supporting a protective canopy. In its last configuration, the multi-function rescue product 207 can be inflated to a raft constructed from radar, solar, and infrared reflective material.

FIG. 7 shows construction of rescue product 207 in cross section, highlighting the various chambers and their

EXHIBIT IV
Page 52 of 54 pages

5.855.454

17

sequence in inflation. life ring 21 first. portion of floor 31. remainder of floor 41 second. high volume tube wall 51 third. arch canopy tube 60 last. Ideally, the floor is doubled or tripled to provide thermal insulation from the water and puncture resistance.

FIG. 8 scuba diver 202 is shown wearing a heads up, multi-chambered, dedicated, rear mounted, adjustable buoyancy compensator having an inflatable chamber 85 connected with hose 83 through quick release coupling 91, and through one-way pressure release valve 82 to a releasable inflatable shoulder harness 80 that is stowed in a folded configuration. In FIG. 9, the shoulder harness 80 is inflated. In FIG. 8, an alternate or concurrent surface flotation bladder having an inflatable chamber 90 can be connected to buoyancy compensation chamber 85 by tube 93, which is regulated by one-way check valve 92, and can be separated from the diver for rescue, salvage or marking activities by quick release coupling 91. In FIG. 8, it is noted that the life vest comprised of inflatable chambers 85 and 90 is snug but releasably attached to diver 202 by a crotch strap 94. The diver 202 in FIG. 8 is holding an air hose 191 which couples to the male quick release coupling 192 on the power inflator 87, or can be used to inflate rescue product 207 of FIG. 2 or can be used as a high pressure air source for the rapid inflation of chamber 90 when it is being used in a rescue attempt. Additionally, a counterweight 100 can be provided (FIG. 50).

FIG. 9 shows an adjustable buoyancy compensation chamber 85 reduced in volume by rolling up the side chamber as shown at 130. An automatic rupturing emergency ascent chamber 180 is inflated from buoyancy compensation chamber 85 through quick release coupler 91, or by a separate compressed gas cylinder such as a CO2 cylinder 215. Standardized retaining strap 110 as found on all the interchangeable forward bladders. Strap 110 keeps bladder 180 from separating from diver 202 until the quick release buckle 103 is opened. Retaining band 104 is expandable allowing for the forward chamber to expand away from the diver upon inflation. In an uncontrolled ascent the diver is unlikely to operate the venting mechanism 183 in which case a rupture plug 182, can be provided, which crosses a weld line 181 weakening it so that as the chamber 180 pressurizes upon ascent, it will rupture out at the weakened point, thereby reducing total lift attached to diver 202 and helping to control the ascent velocity. In FIG. 10 diver 202 demonstrates two of a wide variety of different releasable forward chambers indicated generally as inflatable means 90 stored in the waist band in FIG. 8. Additionally, a counterweight 100 can be provided (FIG. 51).

FIG. 10 shows the diver 202 whose waist band 95 is retaining releasable separating forward chamber 97 which is a redundant horse collar life vest and rescue product. Expandable element 104 stretches upon inflation of the forward chamber 97. In an emergency the horse collar vest 97 can be released from the divers buoyancy compensator by quick release buckle 103. The same quick release buckle is used for releasing the shoulder strap as is standard in the art, and familiar to divers. After releasing the forward vest 97 from the waist, the diver then disconnects the horse collar life vest 97 from its source of power inflation the buoyancy compensator 85, by using the quick release coupling 91. Once the forward chamber has been separated from the rear chamber 85 and diver 202, it can be employed as a rescue board, tied off as a bottom marker, left at the surface to warn boat traffic, or held aloft as a high visibility distress marker. In FIG. 10, the diver 202 is carrying a rescue board, distress marker, surf mat as an alternate separating forward surface

18

flotation chamber indicated as 96. Chamber 96 can be retained by guides 110 on strap 104 of the divers waist band. In FIG. 10, chamber 96 is shown with oral inflation means 98 and quick release coupling means 192 which couples to quick release coupling 91 thereby connected to the rear buoyancy compensator 85, or to the air hose from the air cylinder for more rapid inflation. Retaining flap 106 serves to store the releasable forward chamber 97 or 96. Pouch 160 is sealed by flap 161 and is used to contain a small amount of lead shot to offset the buoyancy of the materials used to construct the forward chamber as well as its containment system. On the upper shoulder straps of the diver 202 in FIG. 10, D-ring 172 is attached to hook and loop covering flat 173 that is attached to underlying fabric walls 175 to create a quick release pocket for a lead shot filled pouch 174.

FIG. 11 demonstrate the pyramidal structure of the multiple chambered heads up life vest. The vest is comprised of a rear U-shaped buoyant chamber 121 and the forward centrally located buoyant chamber 120. The triangle 123, formed by chamber 120 and 121 has a single righting moment, face up. The victim 201, and his airway 124 are maintained out of the water whether or not the victim is conscious. A counterweight 100 can also be provided with the life vest (FIG. 52).

FIG. 12 shows a composite of the water safety and survival elements disclosed herein. In FIG. 12 the diver 202 is unconscious but his airway 124 is held out of the water. A generic centrally located inflated chamber 105 is retained by expansible strap 104 and could be released by quick release buckle 103 if the diver was alert and it was needed for rescue or for use as a distress marker for search and rescue activities. Waist band 95 is secured in place by buckle 178 which is mounted on a Velcro® base 179 that allows the waist buckle to be adjusted along the length of the left side of the waist band 177 to accommodate the variation in waist size that occurs as different types of thermal protective gear are worn. The buckle 178 is off to the side so that the generic forward flotation chamber 105 retains its critical central location. The forward chamber retaining flat 106 is attached by hook flap 108 to the loop material that covers the entire length of the waist band indicated as strap 95. This allows the forward chamber 105 to be quickly but securely adjusted to its central position. Operation of forward chamber 105 is regulated by the variable fabric valve 171 built into the retaining flap 106. The hook and loop components 171 of flap 106 can be varied by the inclusion of a reducer strip of hook 107. The size of the reducer strip 107 determines whether the flap 106 will open quickly under pressurized inflation from the rear chamber 85, open slowly or not at all. If the entire reducer strip 107 is removed the hook and loop means 171 are of sufficient strength to lock off the forward chamber. An over pressure valve 111 is located on the opposite side of the chamber 85 so that the diver can vary the position of the power inflator from the rear to the front by interchanging the power inflator 87 and over pressure relief valve 111. Rescue product 207 is contained in a pocket built into the rear wall of the buoyancy compensator 85 and is accessible by strap 211. Rescue product 207 is attached to the diver by a releasable lanyard 212. The tank compensating keel weight 100 is permanently attached to the tank retaining strap 109. Ideally, the tank compensating keel weight 100 is of a hydrodynamic conformation, made from a dense substance such as lead, coated in a soft film such as plastic so it will facilitate keel weight 100 being securely clamped in place by cam buckle 101. The soft coating will also avoid damaging the protective coating of the tank 102. The tank compensating keel weight 100 may be replaced by

EXHIBIT
A
Page 32 of 44 pages

a standard lead weight so that the diver traveling abroad will not have to transport a lead weight. A diver in tropical waters may only require 5 pounds to descend while use of a dry suit in cold water can require 40 lbs. or more to be able to submerge, the greater the weight of keel weight 100, the stronger the face up righting moment it will generate. As the weight belt is increased because of the use of buoyant thermal protection, it is critical the keel weight 100 be increased. Regardless of the size of the keel weight 100 it is critical that it be located exactly opposite the diver and thus its position must be adjustable so that as the diver changes between diving cylinders of different diameters, keel weight 100 can be easily adjusted, by a non-user, to maintain its critical position. Ideally strap 109 is marked with a scale 176 to guide the diver in selecting the correct placement of keel weight 100 on cylinders of different diameters. If the keel weight 100 is slightly off center, it could summate with an imbalanced weight belt and stabilize the diver in side up position which will allow the airway 124 to submerge. Because the position of the keel weight 100 cannot be compromised, the cam buckle 101 is moved to a less accessible position on the side. A waist buckle 178 is attached to a hook fastener base 179 that allows it to be positioned anywhere along the left side of loop fastener covered waist band 177.

FIG. 13 discloses one of many designs for the construction of an adjustable buoyancy compensator 85. The portion of the buoyancy chamber that is held inaccessible to inflation is indicated as a rolled up portion of the buoyancy compensation chamber 130. The loop portion of a hook and loop fastener forms the inside back of the buoyancy compensator and is indicated as 131. Loop 131 serves to attach the side chamber 136 by hook strips 132 to the body of the buoyancy compensator 85. Flap 138 is formed from the forward facing loop strip 137 and the rear facing hook strip 132. As the volume of the buoyancy chamber is reduced by rolling up the side chambers, the hook strip 132 adheres to the loop strip 137 to form and secure the roll 130. Clip 196 secures the rolled up grommets to prevent the chamber from unrolling under pressure from the air in the buoyancy compensator 85. The portion of the buoyancy compensator behind the neck is indicated as 134. In the current drawings the side chambers 136 are reduced in an infinitely variable fashion and an indicator 133 informs the diver of the remaining amount of lift provided by the buoyancy compensator 85. The indicator 133 allows the diver to quickly return to preestablished buoyancy compensator lift volumes as indicated for a particular set of dive gear. Quick release shoulder strap buckles 135 rely on quick release buckle 103 and are common in prior art. The lower shoulder straps 195 rely on nylon webbing loop 194 to establish structural integrity and internal hook fastener for positioning webbing loop 194 on the loop fastener covered nylon webbing waist band 95 and 177.

FIG. 14 depicts another retaining system for reducing the volume of adjustable buoyancy compensator 85. Double sided hook strip 151 and double sided loop strap 150 are used to lock off the reduced portion of the buoyancy compensator chamber 85. Double sided hook flap 152 attaches the rolled up chamber securely to the loop covered body of the buoyancy compensator 85. The reducible portion of the buoyancy compensator chamber is indicated as 136. The portion of the buoyancy compensator 85 that supports the neck and head is indicated as 134. The keel weight 100 is threaded on tank band 109, that is secured to the air cylinder by cam buckle 101. The hook flat 161 seals off the lead shot filled pouch 160 used to neutralize the inherent buoyancy of the buoyancy compensator.

OPERATION OF THE INVENTION

In FIG. 1, the water enthusiast is shown wearing a traditionally designed vest 203 which could be used in any recreational water sport. The vest 203 contains a multi-function rescue product and raft 207 within its rear pocket. If the ocean kayaker should become separated from his kayak at sea the victim 201 could pull on lanyard 211 and remove the rescue product and begin inflating it. A releasable attachment cord 212 will keep the rescue product from blowing or washing away. Because the vest 203 includes quick release coupler 91, the vest can also eventually be used as a forward chamber with the appropriate dedicated buoyancy compensator if the user becomes certified in diving.

FIG. 2 shows that the diver 202 wearing a current vest style buoyancy compensator 204 can adapt the rescue product 207 contained in pocket 210 to be carried between the diver and the tank by use of a strap 23 which passes through the arm holes of the buoyancy compensator. Access and use of the rescue product 207 is the same as described in FIG. 6 below.

FIG. 3 shows the victim 201 of a common carrier accident wearing a traditionally designed inflatable vest 205, modified with pocket 213 which contains a single use multi-function rescue product and raft 207 constructed from a mylar film and vacuum packed much as a single use raincoat. After surviving the initial entry the product is inflated and used as a life ring, then rescue board or distress marker, and finally inflated to a raft if necessary to remove the victim from the hypothermic effects of the water.

FIG. 4 shows the airline or ferry safety seat cushion 206 containing the multi-function rescue product and raft 207. The victim's arms are placed through straps 15. The cushion 206 provides minimal safety in the water. The incorporated rescue product 207 would confer dramatic improvements in survival at sea.

Referring to FIG. 5, as the user exhales through oral inflator 16, the air passes into manifold 17 that connects multiple chambers to the oral inflator 16. The air is directed to the appropriate chamber according to the diameter of the tubing indicated as 20, 30, 40, 50, and 60. The one way check valves 19, 29, 39, 49, and 59 create structural integrity for each of the chambers down stream. If a puncture should occur only that chamber will lose pressure. If the oral inflator fails, the manifold 17 at its barbed connectors 18 can be disconnected from connector tubes 22 allowing separate inflation through each check valve. The simplicity of a single oral inflator will help the victim focus on a single task. Obviously, separate oral inflators could be used and the significance of which oral inflator is to be inflated first could be printed on the raft in multiple languages.

FIG. 6 is a top view of the multi-function rescue product and raft 207, fully inflated. The life ring 21 because of its small diameter is inflated first and quickly because of its low volume. This life ring could be used by the individual or extended to a family member. The floor chamber 31 and 41 would be inflated next also because they are low volume. Once inflated the first three chambers forms a float that gives the victim a sense of accomplishment. Inflated chambers 21, 31, and 41 create a four foot rescue board for approaching a flailing, distressed victim. The float can also be held aloft as a high visibility distress marker signaling other victims or search and rescue efforts. The inflated floor also gives a platform for the victim to rest on. If necessary the victim can rest on the first three chambers as they begin inflating the high volume side wall tubes 51. Once inside the raft the

EXHIBIT A
pages 34 of 167

5.855.454

21

infrared reflective mylar would help to offset further loss of body temperature. Finally, the canopy arch 61 is inflated and the victim creates an enclosed space that is highly visible to the naked eye as well as radar. The multiplicity of chambers confers protection from puncture.

FIG. 7 is a view of the inflated raft 207 in cross section. The sequence of inflation, 21, 31, 41, 51, then 61 shows how the life ring would convert to a rescue float and ultimately to a raft.

FIG. 8 shows the scuba diver 202 holding a pressure hose 191 with its common female quick release coupler 91 disconnected from the male quick release coupler 192 of the power inflator 87. The common female coupler 91 can be attached to any of the other incorporated chambers such as the horse collar vest which is deflated and stored in the shoulder straps indicated at 80, or any of a multiplicity of deflated chambers that can be interchangeably stored in waist band as indicated at 90 or in the pocket. The high pressure hose 191 is employed to effect a more rapid inflation in an emergency. For routine operation of the chambers stored in the waist band or shoulder straps, they are in fluid communication with the buoyancy compensator chamber 85 through quick release couplers 91 and check valves 92. The crotch strap 94 is the only way the user can be assured that he will not be separated from his inflatable rescue product in heavy surf. With the auxiliary chambers deflated and stored, the diver has a sleek profile with reduced hydrodynamic drag while swimming under water. Most importantly with the high lift surface flotation chamber stored it will not contribute its buoyancy to the total lift available to the diver under water.

FIG. 9 shows a diver 202 with a redundant separating shoulder mounted horse collar 80 inflated. The diver also is demonstrating the self rupturing emergency ascent chamber 180 inflated at the diver's waist. It is to be noted that the dedicated adjustable buoyancy compensator 85 has been reduced by rolling up the lower portion of the chamber as indicated at 130. If this reduced chamber was providing insufficient lift at a depth and the diver chose to attempt an emergency buoyant ascent the forward chamber 180 at the waist could be released. If the diver was out of air, the air pressure in the rear chamber would spill forward causing chamber 180 to inflate. Alternatively, chamber 180 can be inflated from its own compressed cylinder 215 when chamber 180 is disconnected at quick release coupling 91 or if air cylinder 102 and buoyancy compensator 85 are both empty. If the emergency ascent was uncontrolled, and the diver forgot to deflate chamber 180, it would self destruct at rupture plug 182, releasing its entrapped air that had become pressurized because of the ascent. At that point the ascent rate would slow allowing the diver to regain control, further slowing his ascent rate to within the recommended rate of 20 to 30 feet per minute, rather than the ascent rates of 200 to 300 feet per minute, generated during an emergency buoyant ascent. If the diver should snag a fish hook in their primary chamber 85, then the horse collar vest stored in the shoulder straps would provide a redundant personal safety vest. In the event that the diver needed to ditch the dive gear, the power inflated forward horse collar safety vest can be quickly disconnected by quick release coupling 91. Alternatively, the horse collar can be separated and extended to the diver's buddy who has suffered a failure of his single chambered buoyancy compensator. If the diver was snorkeling the horse collar safety vest could be disconnected and inflated via oral inflator 84 and used independently from the remainder of the heads up safety vest.

FIG. 10 shows a diver 202 with a flap 106 which was used to enclose the flotation chamber 97 now shown in the open

22

position. In front of flap 106 is the separating horse collar forward surface flotation chamber 97, inflated at the diver's waist. The forward chamber is retained by elastic webbing 104 that allows the chamber to expand away from the diver rather than constrict the diver's abdomen and therefore breathing. Quick release buckle 104 allows the diver to separate the forward bladder which can then be disconnected via quick release coupler 91. Once the flotation chamber 97 is free it can be used as a rescue float for approaching a hypoxic diver, held aloft as a distress marker, left floating at the surface to warn boat traffic of diver activity, used underwater as a bottom marker in search and rescue activities, or used as a small salvage device. For rapid emergency inflation the product can be stored in a pocket and connected to the air hose. Chamber 97 as it is currently shown is retained by strap 104 providing the central point of buoyancy that contributes to the heads up surface position. Though not required, the diver can be provided with quick release shoulder trim weights 174, retained by hook and loop fastener 173 and 175. The diver by pulling on D-ring 172 peels open the pocket and lead shot filled container 174 can fall away from the diver. The trim weights are exactly opposite the site of underwater buoyancy contained in the buoyancy compensator and helps the diver achieve an ideal balanced underwater and surface position. The diver 202 is also shown carrying an alternate forward or flotation chamber 96 which can be substituted for chamber 97 and secured to the diver by elastic retaining strap 104 which passes through strap eyelets 110 mounted on the edges of bladder 96. This larger float has all the same functions of the horse collar forward chamber 97 with the addition that it can be used as a transport raft for a disabled diver or act as a surf mat at the end of the dive for swimming back to shore.

FIG. 12 illustrates a composite of several of the disclosed inventions. The multi-chambered heads up safety vest modified for use by the scuba diver by inclusion of tank bands 109 which attach the tank 102 to a fully inflated adjustable buoyancy compensator 85. The tank bands 109 are longer than those currently located on buoyancy compensators in the marketplace. The extra length in tank band 109 is needed to allow the diver to thread on the tank compensating keel weight 100. The keel weight 100 can be located on the top, bottom, or on both tank bands 109 as needed. A diver in a bathing suit needs to locate the keel weight on the lower band. A diver wearing a buoyant thermal protective suit requiring a weight belt can shift the keel weight to the top tank band 109 to establish the ideal surface position. Cam buckle 101 is located off the side of the tank 102 so that the back side of the tank is available for placement of the keel weight 100. Over pressure relief valve 111 is located opposite the buoyancy compensator power inflator 87 allowing the two to be interchanged. The beginner is accustomed to the power inflator 87 coming over the shoulder but when located in this position power inflator 87 floats free and is often hard to locate underwater. When the power inflator 87 is mounted on the front of the buoyancy compensator chamber 85 it hangs straight down between the diver and the tank and is easily located when needed. The multi-function rescue product and raft 207 is located between the diver 202 and the tank 102. Lanyard 211 wraps around rescue product 207 allowing the diver to remove the rescue product 207 for use without having to remove any other dive gear. A generic forward chamber 105 is inflated and retained by elastic strap 104. The flap 106 includes a variable fabric valve comprised of hook and loop fasteners 171 that variably regulates the use of the forward chamber 105. Reducer hooks strip 107 decreases the amount of interactive surface in the fabric

valve allowing the diver 202 to vary the operation of the fabric valve from automatic to semi-automatic, to manual. With the reducer strip in place the air pressure from the rear chamber is capable of forcing open the valve deploying the forward chamber without the diver needing to do anything. In the semi-automatic mode, the diver 202 partially removes the reducer strip 107, now the fabric valve 171 will swell because of the mounting air pressure, after a period of time flap 106 will eventually open. As the diver becomes more skilled and capable of operating the fabric valve 171 in flap 106 in the manual mode, he will totally remove the reducer strip 107. With no reducer strip 107 in place the strength of the fabric valve 171 exceeds the 2.5 psi over pressure relief valve 111 on the rear chamber or the small bore over pressure relief valve built into the oral inflator 193. On a rapid ascent from significant depths, pressure will build up at such a fast rate that the small bore oral inflator over pressure relief valve 193 cannot keep up and the forward chamber will rupture, protecting the diver from any further acceleration and will contribute to the diver's deceleration by removing the buoyancy contributed by the forward chamber. With no reducer strip 107 in place the high lift surface flotation device is safely locked away while the diver is underwater, reducing the amount of lift attached to the diver's body that entraps air or could be inflated by panic or mechanical failure of the power inflator 87. Waist band buckle 178 is attached to hook and loop base 179 that allows the diver to quickly and reliably shift the position of the waist band buckle 178 to adapt the product to different divers or the same diver with different thermal protective gear.

FIG. 13 illustrates one way that an adjustable buoyancy compensator 85 can be assembled from the front. The body of the buoyancy compensator 85 is covered with loop fastener 131. The inside edge of the side chamber forms a flap 138 which has loop fastener 137 on the front side and hook fastener 132 on the back side. As the chamber is rolled up the hook and loop adhere along the inside edge and clip 196 locks the outer edge from unwinding under pressure from the air contained in the buoyancy compensator. The adjustable buoyancy compensator 85 gives the diver the ability to further reduce the amount of lift attached to his body to the absolute minimum needed for each dive profile and dive environment. Reducing unnecessary risk of rapid ascent, embolism and the bends.

FIG. 14 shows an alternate way to reduce the volume of a chamber using hook straps 151 and loops traps 150. As the chamber is rolled up to the desired amount of lift as indicated on indicator gauge 133, straps 150 and 151 are fastened. The side chambers are attached to the loop body of the buoyancy compensator by way of hook strap 152. Hook flap 161 closes loop pouch 160 that contains lead shot to neutralize the inherent buoyancy of the buoyancy compensator 85 so that ballast is not consolidated onto the weight belt. Keel weight 100 is shown on the top tank band 109. There are many ways that the chambers could be secured after being reduced in volume such as by buttons, snaps, zippers, pins, constricting bands, fabric flaps and fabric valves. The final result is that the diver can vary the volume of their buoyancy compensation chamber as required for a safe dive.

The side chambers 136 can be rolled to any point as indicated by the demands of the particular dive. Double sided velcro loop 150 connects with double sided hook 151. A piece of double sided velcro hook 152 attaches to the loop body of the buoyancy compensator. The cam buckle 101 of tank band 109 generates the pressure between the buoyancy

compensator and the tank and secures the hook strap 152 from peeling off. In an emergency at the surface the reduced volume can be accessed by releasing the velcro valve straps 150 and 151. It is noted that the chamber behind the neck 134 is not accessible to being reduced.

SUMMARY, RAMIFICATIONS, AND SCOPE

Accordingly, the correct positioning of a very small amount of buoyancy can accomplish what five to ten times that same amount of buoyancy cannot, a single heads up righting moment that will protect the airway. After surviving the initial entry into the water, signaling search and rescue efforts can make the difference between life and death. Dual tragedy is the term applied to the death of the rescuer by a hypoxic victim, an inflatable float is one of the safest ways to approach a floundering victim. It can take hours for available life rafts to round up survivors, often victims who have survived the initial insult of entry perish within thirty minutes of hypothermia. The only solution to hypothermia is to remove the victim from the water whether they are waiting to be picked up by the life raft of it they are going to be spending an extended period at sea until land based search and rescue efforts arrive. The multi-function rescue product and raft comprised of a multiplicity of chambers, constructed from the appropriate material, can be built into the heads up safety vest where it is safely stored until needed.

The principles of a heads up safety vest need to be modified for use underwater by separating out high lift surface flotation, incorporating a variable volume buoyancy compensation chamber that can be reduced to the lowest volume necessary for a particular set of dive gear and dive environment. The current invention makes great strides in reducing the emergency ascent rate and thus reducing the exposure to pulmonary barotrauma, arterial gas embolism as well as the chances of developing decompression sickness. The buoyancy of some air cylinders when empty and the use of a primary back mounted buoyancy compensator, require the addition of a tank compensating keel weight to assure the diver that with or without the deployment of the forward chamber that once the diver is at the surface, that their only inflatable product will roll them over and place their airway out of the water if they are unable to do so themselves. A third self rupturing emergency buoyant ascent chamber can be an option if the diver insists on using an underwater propulsion device. The incorporation of numerous rescue devices as integrated chambers in fluid communication with the power inflated dedicated buoyancy compensator, allows the user rapid access to rescue boards, distress markers, transport rafts, dive site markers, underwater markers, salvage devices, tender crafts and surf mater. This wide range of power inflatable products confers significant advances in water safety, survival and enjoyment.

FIGS. 15 through 25 illustrate a first alternative embodiment for a counterweight assembly 300 which generally includes a weight member 302 and means for attaching weight member 302 to assure reliable and consistent heads up position of the person at surface level. A first means for attaching weight member 302 embodiment includes a pair of vertical slots 304 and 306 defined by weight member 302 and a tank band or strap 320 which includes a first end 322 and a second end 324. A tank band connection member can be provided at first end 322 of tank band 320. Preferably, the connection member is a tensioning device such as a conventional cam buckle 330, however, such is not limiting and other attachment mechanisms, such as D-rings, hook and loop fasteners, magnets, suction cup devices, etc., are considered within the scope of the invention.

good copy of all pages EXHIBIT A

5.855.454

25

To properly attach weight member 302 to air tank 301 second end 324 is inserted through vertical slots 304 and 306. weight member 302 is properly positioned with respect to air tank 301 and tank band 320 is tightly wrapped around air tank 301 with weight member 302 properly positioned. Cam buckle 330 provides for attachment of second end 324 with first end 322 to maintain weight member 302 in proper position along tank 301. Weight member 302 is preferably secured such that the diver or user cannot remove or release weight member 302 during his or her underwater travels. This guarantees reliable and consistent heads up positioning of the diver at the water surface level in the event the diver becomes incapacitated.

A non-skid means can be provided to prevent weight member 302 from moving out of position with respect to tank 301. Preferably, the non-skid means is a non-compressible rubber or plastic member 328 sewn to the inside surface of tank band 320. however, other conventional non-skid means can be provided and are considered within the scope of the invention.

As seen in FIGS. 26 and 27, one or more suction cups 380 can be mechanically fastened into weight member 302 by conventional means. Alternatively, a sheet of suction cups (not shown) can be glued or molded into weight member 302. The sheet of suction cups is provided to cover a majority of the interior surface of counterweight 300. The sheet of suction cups is provided with apertures which are shaped and aligned with vertical slots 304 and 306 and horizontal slots 314 and 316, described in detail below, so not to interfere with the insertion of tank band 320 or coupling strap 340, also described in detail below, through slots 304 and 306 or 314 and 316, respectively.

In either suction cup embodiment, the suction cups are provided to provide a quick attachment of weight member 302, as well as a quick removal means for weight member 302. The suction cups are particularly useful during training or practices where the exact amount of ballast for the diver or person is uncertain and various weight members 302 of differing weights are to be attached and detached from cylinder 301 until the proper amount of ballast (weight) required for the specific individual is determined. Without the suction cups, the trainer or person determining the proper amount of ballast (weight), has to repeatedly attach and detach various weight members 302 via straps 320 or 340 as described above, which is very time consuming. The use of suction cups provide a quick and accurate method for readily determining a proper weight member 302 for the individual.

Additionally, the suction cups are also useful for maintaining weight member 302 in proper position, while weight member 302 is properly secured by either tank band 320 or coupling strap 340 in conjunction with strap 360 of buoyancy compensator 359.

Alternatively, a hook and loop/pin/snap system along the tank's longitudinal axis would allow rapid determination of size and location by a dive master/instructor. Thus, a multitude of known attachment devices could be incorporated and utilized by a second person assisting the user for determining the proper size and location of the weight member for the specific user.

An alternative means for attaching weight member 302 embodiment includes a pair of horizontal slots 314 and 316 and a relatively small coupling strap 340 for joining weight member 302 to a conventional buoyancy compensator strap 360 which is provided for conventionally attaching air cylinder 301 to a conventional buoyancy compensator 359.

Coupling strap 340 includes a first end 342, a second end 344, an outer surface 346 and an inner surface 348.

26

Preferably, hook and loop fastening means 350 and 352 are provided on inner surface 348 at first end 342 and second end 344, respectively. However, other conventional attachment means, though not preferred, can also be utilized and are considered within the scope of the invention. Coupling strap 340 can also be provided with a pull strap 354 at first end 342.

To properly attach weight member 302, cylinder or tank 301 is initially conventionally loosely attached to buoyancy compensator 359 in conjunction with strap 360 which utilizes a conventional cam buckle for its connection means. Once cylinder 301 is loosely attached to buoyancy compensator 359, first end 342 of coupling strap 340 is inserted between strap 360 and cylinder 301. Second end 344 of coupling strap 340 is inserted through horizontal slot 314 or 316 from behind weight member 302 and then back through the other horizontal slot 316 or 314, respectively, for attachment to first end 342 by mating of hook and loop fastening means 350 and 352. Strap 360, having weight member 302 attached thereto, is tightened around cylinder 301 in conjunction with its cam buckle as is conventionally known, to securely attaching cylinder 301 to buoyancy compensator 359. It is to be understood that the roles of ends 342 and 344 can be reversed with second end 344 being inserted through and between strap 360 and cylinder 301 and first end 342 being inserted through horizontal slots 314 and 316 for mating with second end 344.

Prior to tightening strap 360, weight member 302 is properly positioned with respect to cylinder 301 and preferably, the mating of first end 342 to second end 344 is positioned between buoyancy compensator strap 360 and cylinder 301. This attachment position prevents inadvertent detachment of ends 342 and 344 from each other, once strap 360 is properly tightened, thus, assuring that weight member 302 will remain properly secured.

A slight recess 319 on the interior aspect of weight member 302 is preferably provided when attaching weight member 302 by a coupling strap 340. As the cam buckle generates tension in the buoyancy compensator strap 360, the tension also pulls on coupling strap 340. This pulling on coupling strap 340, tightens the attachment of weight member 302 to strap 360. The secured and tightened strap 360 compresses the hook and loop attachment of ends 342 and 344, thus, preventing accidental release. The point where ends 342 and 344 are positioned between strap 360 and cylinder 301 protrudes outward slightly which is received within recess 319 of weight member 302, when weight member 302 is properly secured. Thus, recess 319 helps couple weight member 302 specifically to the exact shape of each tank or cylinder 301 so that there is no opening to ensnare objects underwater.

When removing weight member 302, strap 360 is loosened by conventional means, and tab 354 is pulled to break the attachment of ends 342 and 344 to each other, which allows weight member 302 to be removed. However, it is important to note, that weight member 302 is preferably secured such that the diver or user cannot remove or release weight member 302 during his or her underwater travels. This guarantees reliable and consistent heads up positioning of the diver at the water surface level in the event the diver becomes incapacitated.

The threading of the cam buckle, in conjunction with strap 360, is a complicated process. Thus, by providing slots 314 and 316 and coupling strap 340, weight member 302 can be removed without having to re-thread the cam buckle.

Preferably, buoyancy compensator strap 360, similar to tank band 320, is provided with a non-skid means to prevent

tank 301 from moving out of position with respect to its attachment by strap 360 and assuring that weight member 302 remains properly placed with respect to tank 301. Also like tank band 320, in the preferred embodiment, the non-skid means is a non-compressible rubber or plastic member 363 sewn to the inside surface of strap 360.

Preferably, the radius of weight member 302 is the same as the cylinder or tank 301 to which it is attached to prevent snagging of various underwater objects, such as fishing lines, when a diver, having a tank 301 and counterweight assembly 300 attached to his or her buoyancy compensator, is moving underwater. Accordingly, weight member 302 is preferably configured specifically to tank 301's circumference and is provided with a feathered edge (rounded/tapered leading edge) to eliminate any gaps which might snag kelp.

Though the various counterweight assembly described above and below are discussed in conjunction with a buoyancy compensator, it should be understood that the counterweight assemblies can also be utilized with personal flotation devices such as life jackets and life vests. Thus, where reference is made to a buoyancy compensator throughout the application, it is also intended to include other personal flotation devices such as the life jackets and life vests.

Weight member 302 can be provided with a soft coating to also prevent weight member 302 from sliding when properly attached, as well as increasing the adherence of weight member 302 and buoyancy compensator 359 to cylinder 301. The soft outer coating of weight member 302 also protects cylinder 301's protective and cosmetic coating from being scratched.

Weight member 302 is provided with a relatively thin flat profile which increases the total surface area between weight member 302 and cylinder 301 and increases the security of the attachment of buoyancy compensator 359 to cylinder 301. The lower profile is designed to provide less drag and less chance of snagging underwater objects such as kelp. Weight member 302 can be provided with a feathered edge to couple specifically to the exact shape of each tank or cylinder 301 so that there is no opening to ensnare objects underwater.

Preferably, weight member 302 can weigh approximately six (6 lbs) pounds. However, this weight amount is not limiting, and other weight amounts for weight member 302 can be utilized, as determined by a particular diver's needs, and are considered within the scope of the invention.

FIGS. 28 through 30 illustrate a second alternative embodiment counterweight assembly generally designated as reference numeral 400. Counterweight assembly 400 can either be utilized with conventional buoyancy compensator strap 360 or can be utilized in conjunction with a tank strap or band 420, which is similar to tank band 320. Counterweight assembly 400 consists of a flexible pouch member 430 and one or more weight members 460. Pouch member 430 is preferably constructed from a fabric material, and can be either slidably and removably attached or permanently attached to either tank band 420 or buoyancy compensator strap 360.

When removably attaching pouch member 430 to either tank band 420 or strap 360, a loop member 434 is preferably attached to the back of pouch member 430, by conventional means such as stitching, and either tank band 420 or strap 360 is inserted through loop member 434 until pouch member is properly positioned with respect to cylinder 301. Where strap 360 is utilized, pouch member 430 is preferably properly positioned prior to final tightening of strap 360 around cylinder 301.

Alternatively, two loop portions (not shown) can be provided each being attached at their respective first ends to pouch member 430 by conventional means such as stitching. The second outer ends of the loop portions can respectively be provided with attachment means such as hook and loop fasteners. When removably attaching pouch member 430 to strap 360 or tank band 420, the outer ends of the loop portions being disposed between strap 360 or tank band 420 and cylinder 301, where the loop portion outer ends mate to define a loop member. Once the outer ends are mating and properly positioned, strap 360 or tank band 420 is properly tightened sandwiching the outer ends between cylinder 301 and strap 360 or tank band 420 to prevent inadvertent releasing of the outer ends, as well as assuring proper positioning of pouch member 430.

When permanent attachment of pouch member 430 is desired, such attachment is preferably accomplished by conventional means such as stitching or sewing (FIG. 29). Preferably, the permanent attachment of pouch member 430 to tank band 420 or strap 360 is such that pouch member 430 is properly positioned when tank band 420 or strap 360 is tightened.

Pouch member 430 can be provided with a plurality of individual weight receiving pockets 432. Preferably, four (4) to eight (8) individual pockets 432 are provided. However, this number of pockets 432 is not limiting, and other pocket 432 amounts can be provided and are considered within the scope of the invention. Alternatively, pouch member 430 can be provided with large weight receiving area.

Individual weights 460, which act as ballast members, can be inserted into one or more of pockets 432 or into the large weight receiving area, depending on the amount of weight required. Alternatively one large hard weight (i.e. lead, steel etc.) or soft weight (i.e. sand, loose ballast, etc.) can be provided in the large weight receiving area. Weight members 460 are preferably constructed from lead, though other materials can be utilized and are considered within the scope of the invention.

The use of one or more weight members 460 allows for fine tuning of the amount of weight necessary for reliable heads up positioning at water surface level of an incapacitated diver, taking into consideration the diver's weight, equipment, etc. Thus, the exact amount of weight or ballast can be provided to assure that the user's airway will be protected in the event of an emergency.

A flap member 440 can be attached to pouch member 430 by conventional means such as sewing or stitching. In use, flap member is folded over and attached to pouch member 430 preferably by conventional means such as by the mating of hook and loop fasteners 435 and 437 disposed on at least a portion of an inner surface of flap member 440 and on at least a back outer surface of pouch member 430. However, other attachment means can be provided such as snaps, buttons, zippers, etc., and are considered within the scope of the invention. Flap member 440 prevents weight members 460 from inadvertently being removed from their placement within pocket member 432 or the large weight receiving area. Thus, when counterweight assembly is properly positioned, flap member 440 is compressed, to guarantee it remains in its closed position, by tank strap 420 or strap 360. Flap member 440 can be provided with a non-skid member 441, similar to the non-skid members discussed above.

Additionally, in lieu of inserting weight members 460 across in a horizontal manner, pouch member 430 can be constructed such that the weight members are inserted within pouch member 430 in a vertical fashion. Preferably,

EXHIBIT A
Page 28 of 141 pages

each individual weight member 460 weighs approximately two (2 lbs) pounds, though such is not limiting and other weight amounts can be utilized and are considered within the scope of the invention. Furthermore, weight members 460 can be symmetrical, however, such is also not limiting.

Pouch member 430 can be constructed from neoprene, spandex, canvas, nylon, or other conventional soft and flexible fabric materials. Furthermore, elastic or other stretch means can be incorporated into pouch member, to assure a tight and snug fit of one or more weight members 460 within pouch member.

In this embodiment, pouch member 430 is preferably secured such that the diver or user cannot remove or release weight member(s) 460 during his or her underwater travels. This guarantees reliable and consistent heads up positioning of the diver at the water surface level in the event the diver becomes incapacitated. This feature of not allowing the diver or user from having access to the weight members during his or her underwater travels is found in all of the tank mounted counterweight assemblies of the present invention, described above or below.

As seen in FIGS. 32 and 33, one or more individual weights 500 can be attached directly to conventional buoyancy compensator strap 360 or to tank band 320. In this counterweight assembly embodiment, weight members 500 are provided with a slot 502 for insertion therethrough of either strap 360 or tank band 320. Similar to above, a non-skid means (not shown) can also be provided on either strap 320 or 360 or weight members 500 to prevent weight members 500 from moving out of proper position. Also similar to above, the number of weight members 500 provided is dependent on several factors such as diver's weight, equipment weight, etc. Weight members 500 are preferably constructed from lead or steel, though other materials can be utilized and are considered within the scope of the invention. Weight members 500 preferably weigh between one (1 lb) pound to three (3 lbs) pounds each. However, this weight amount is not limiting, and other weight amounts for weight members 500 can be utilized and are considered within the scope of the invention.

As seen in FIGS. 34 through 36, a weighted sleeve member 600 can be positioned along tank or cylinder 301 to provide ballast in order to assure heads up positioning at water surface level of an incapacitated diver. Weighted sleeve member 600 is tightly slid along cylinder 301 to its proper position with respect to cylinder 301. Weighted sleeve member may be fastened by conventional means such as bolting.

A flexible pouch member 620, similar to the various embodiments pouch member of described above and below, can also be provided in addition to weighted sleeve member 600. Pouch member 620 can be provided with one or more weight 630 receiving pockets 632. Pouch member 620 is preferably constructed from a fabric material and can include a flap member (not shown). Pouch member 620 is preferably disposed around sleeve member 600 and can be attached by conventional means such as hook and loop fastening members 622 or by buckle means. Thus, weighted sleeve member 600 can have a non-user releasable connection securing an additional counterweight assembly to weighted sleeve member 600. Furthermore, weighted sleeve member 600 can be positioned at the bottom of tank 301 for use in warm water.

Alternatively, a pouch member 650 (FIG. 36), can be provided which is constructed from a rigid material, such as plastic and is preferably constructed integral with sleeve

member 600. Pouch member 650 can be provided with one or more weight 630 receiving pockets 652. Rigid receiving pockets 652 can be provided with holes in their bottom to push weight members 630 out after the dive. As receiving pockets 652 are constructed from a rigid material, preferably, the weight members to be inserted within, should correspond in shape to pockets 652. Furthermore, conventional cap means is preferably provided for each pocket 652 to prevent the weight members from falling out during the dive. Pouch member 620 or 650 and sleeve member 600 function similar to the other embodiment pouch members of the present invention. The lateral edge of weight members 630 can be modified to allow it to easily slide into tracks (pockets 652) built into or formed integral with weighted sleeve member 600.

FIGS. 37 through 39 illustrate another counterweight assembly embodiment generally designated as reference numeral 700. Counterweight assembly 700 includes a pocket member 710 which can be either permanently or removably fixed to buoyancy compensator strap 360 or tank band 320, in any of the methods previously described above, and a hard weight member 780 or soft weight member 790 disposed within a pouch member 740 with pouch member 740 being at least partially disposed within pocket member 710.

Pouch member 740 is provided with a quick release handle 754 which is attached to pouch member 740 by a strap member 770 and allows a person, other than the user, to remove pouch member 740 and weight member 780 or 790 from pocket member 710 when a diver or other swimmer is finished with his or her underwater travels. Normally a person standing on a boat, dock or other type of surface, pulls off the diver's equipment (including his or her buoyancy compensator 359 and attached air tank 301) while the diver remains in the water.

This removal of equipment makes it easier for the diver to climb onto the boat or dock. Buoyancy compensator 359 and air tank 301 typically weigh together approximately fifty (50 lbs) pounds. With the use of certain buoyancy compensators currently available, an attached weight member 780 or 790 may add up to approximately eighteen (18) to twenty (20) additional pounds to the amount of weight the person in the boat has to remove. The person in the boat normally bends over towards the water in order to reach the diver who is in the water. This position, seriously exposes the person's back to strains and pulls, as well as potential hernias. Individuals who work on dive boats are constantly lifting the equipment onto the boat, in such awkward position, throughout the day. Accordingly, any reduction in the amount of weight to be lifted each time, becomes significant when such tasks are performed on numerous occasions during one outing or continuously throughout the day.

Thus, by providing a quick release means for weight members 780 or 790, the person in the boat can initially remove weight members 780 or 790, thus, reducing the weight of the buoyancy compensator and air tank to be lifted by approximately up to eighteen (18) to twenty (20) pounds. This reduction in weight could help to prevent many back problems commonly experienced by persons removing the diver's equipment onto the boat or dock.

FIG. 39 illustrates the various steps of removing quick release weight member 780 or 790 from pocket member 710 by the person on the boat or dock. As previously mentioned, it is to be understood that weight members 780 or 790, as well as all of the counterweight assembly embodiments of the present invention, are positioned such that the weight

EXHIBIT A
Page 29 of 167 pages

5,855,454

31

members cannot be removed or released by the diver in order to assure that the diver is consistently maintained in a heads up position in the event he or she becomes incapacitated.

Pocket member 710 is shown having an outer surface 712. A hook and loop fastening means 714 is provided on outer surface 712 adjacent an open end of pocket member 710. A pocket flap member 716 is provided having an outer surface 718 and an inner surface 720. A first flap hook and loop fastening means 722 is provided on outer surface 718 and a second hook and loop fastening means 724 is provided on inner surface 720. Pocket member 710 can be provided with a perforated portion.

Pouch member 740 houses removable weight member 780 or 790. The weight member can be a sandbag (soft weight 790), lead weight (hard weight 780), or other appropriate ballast member which can be disposed within pouch member 740. A hook and loop fastening means 772 is provided on a first surface of strap member 770 and hook and loop fastening means 776 and 778 are provided on a second surface of strap member 770. A first end of strap member 770 is attached to pouch member 740 and a second end of strap member 770 is attached to handle means 754 both by conventional means. Handle means 754 includes a triangularly shaped gripping member 756 having a gripping surface 758.

Weight members 780 or 790 act as ballast means to assure heads up positioning of an incapacitated diver at water surface level and in use are disposed within pouch member 740 which in turn is disposed within pocket member 710 with strap member 770 and handle means 454 protruding out of pocket member 710. A portion of hook and loop fastening means 724 mates with hook and loop fastening means 778. hook and loop fastening means 772 mates with a portion of hook and loop fastening means 714, and a remaining portion of hook and loop fastening means 724 mates with a remaining portion of hook and loop fastening means 714, by folding flap 716 inward along a fold line 717. At this point, strap 770 is folded inward over flap 716 to allow hook and loop fastening means 776 to mate with hook and loop fastening means 722 to securely retain weight member 780 or 790 within pocket member 710, to assure consistent heads up positioning of an incapacitated diver, while allowing a person standing on a boat or dock to remove weight member 780 or 790 when the diver is ready to climb onto the boat or dock.

To remove weight member 780 or 790, the person on the boat or dock grabs handle means 754 at gripping surface 758 and pulls handle means 754 with a normal, but strong, tugging motion force, which nearly simultaneously breaks the attachment of fastening means 776 to fastening means 722, fastening means 714 to fastening means 724, fastening means 772 to fastening means 714, and fastening means 778 to fastening means 724, to allow weight member 780 or 790 to be quickly removed from pocket member 710. Once removed, the person on the boat or dock, merely drops weight member 780 or 790 and pouch member 740, on the boat or dock, respectively, where it can be properly redispensed within pocket member 710, when the diver or another prepares to enter the water again.

As seen in FIGS. 40 and 41, a combination of the previously described weight members can also be provided. As shown, counterweight assembly 300 is provided with a counterweight assembly 700 attached thereto. Weight member 302 provides a certain amount of ballast (weight), while the amount of ballast (weight member 780 or 790) provided

32

within pocket member 710 varies depending on the weight of the diver and his or her equipment. Though, pocket member 710 is shown removably attached to weight member 302, it is to be understood, that the other pouch members described above, as well as one or more individual weights 500, can also be utilized in combination with weight member 302, and such other combinations are also within the scope of the invention. Furthermore, other combinations of counterweight assembly 700, counterweight assembly 300, individual weights 500 and the other pouch members described above can be provided and are all considered within the scope of the present invention.

To attach pocket member 710, or the other pouch members, tank band 320 is inserted through one of the vertical slots 304 or 306 of weight member 302, through a loop member attached to the back of pocket member (the loop portions described above could also be utilized), through the other vertical slot 306 or 304, respectively, and then tightened by conventional means, such as D-rings members, buckle means, etc. as described above.

Where weight member 302 is attached with buoyancy compensator strap 360, if loop portions are provided, the loop portions can be inserted through horizontal slots 314 and 316 and attached to each other, in lieu of providing coupling strap 340. Thus, in this embodiment, the loop portions provide the mechanism for attaching both weight member 302 to cylinder 301 and pocket member 710 to weight member 302.

It should also be understood in some applications, more than one of the same type of weight member, described above, may be utilized. For example, a first weight member 302 could be attached relatively high with respect to cylinder 301 and a second weight member 302 could be attached relatively low with respect to cylinder 301.

Furthermore, the vertical positioning of any of the weight members described above can be easily adjusted between dives or possibly by a person, other than the diver, during the dive. The weight member and tank band 320 are infinitely adjustable along the length of the horizontal axis. The ability to move tank band 320 and the attached weight member up and down the tank allows for optimal position of the weight member. This in turn allows the angle of the hyperextension of the "distressed" diver's neck at the surface to be accurately adjusted for optimal airway comfort. Thus, tank band 320 can be quickly and securely adjusted to attach the appropriate weight member in the appropriate position in response to any specific set of dive gear or dive environment.

A warm water diver may be diving with a minimal weight belt (i.e. four (4) to ten (10) pounds). Some divers may feel that attaching six (6) pounds of non-releasable ballast to their air cylinder 301 would result in a significant reduction in the amount of releasable ballast at depth. In order to incorporate the critical ballast counterweight (weight member) while preserving the diver's current releasable weight, the diver can use an offsetting buoyant means, fixed or releasable. The diver that requires a four (4) pound counterweight (weight member) to provide reliable airway protection can add a four (4) pound buoyant pad to protect their tail bone from the tank, fill the space between the small of the back and their tank or use the buoyant material to pad the thorax or their head. The foam can be alternatively attached to the front of the buoyancy compensator where it can be released in the event of an uncontrolled emergency (i.e. ascent due to accidental loss of weight at depth as might occur if the weight belt is snagged). The foam on the front

EXHIBIT A
Page 49 of 147 pages

5.855.454

33

would also increase the strength of the face up righting moment at the surface as might be desired by the beginning diver.

It is notable that if the counterweight is large enough it will overcome all other righting moments. The larger the ballast the stronger the righting effect. The balance is that cylinder 301 is already heavy, at the point of barely manageable. The combination of the forward buoyant means and four (4) to eight (8) pounds of ballast in the counterweight keeps the total system light enough that it can be comfortably maneuvered. If the forward chamber is left at the surface to protect the diver from boat traffic then the counterweight must be approximately doubled to preserve the heads up safety feature. If the counterweight is large enough, it can act alone to right the diver. Its key requirement is that it be located exactly opposite the diver, easily adjusted to maintain that position. A securely attached counterweight can be used to retrofit existing buoyancy compensators, as long as they have an adherent element to assure that the counterweight will not slide from position.

The counterweight is critical in balancing out the entire set of dive gear so that in an emergency the diver's gear provides a single stabilized righting moment that places the distressed divers airway out of the water.

The counterweight embodiments described above (FIGS. 15 through 41) can be relatively easily incorporated into other products, such as any and all other life vests, life jackets, etc. Thus, the life jacket or other personal flotation device (collectively referred to as "life jacket") can be provided with a ballast/weight member attached to the back of the jacket, which as a counterweight member to provide angular momentum in rolling the diver or other wearer over in the water, such that the diver floats face up in the water. Preferably, the counterweight is attached posterior central.

A conventional life vest/life jacket can be comprised of inherently buoyant material, such as (1) kapok, closed foam; (2) mixed inherently buoyant material and inflatable ("hybrid" personal flotation device"); and (3) purely inflatable design. All of these design of a lifesaving buoyant means are improved by the addition of the ballast/counterweight. Preferably, the counterweight is able to be varied in size and position depending on the other equipment worn by the user and the user's anatomy. Typically the counterweight is between three (3) and six (6) pounds and is securely attachable to the life jacket adjacent and between the neck and lower back area of the user.

Furthermore, a conventional air tank or cylinder can have a weight member constructed integral with the tank if the intended wearer knows the specific amount of counterweight he or she requires, and the exact location of the weight member with respect to the air tank.

Additionally, where steel tanks or cylinders are utilized, a weight member having magnet means associated there with can be provided for directly attaching the weight member to the tank. This use would only be for training purposes and/or for determining the proper amount of weight, as well as the proper location of the weight on the tank, for the specific individual. This attachment embodiment would not be used during normal dives and underwater travels, as there is a chance that the weight member may move or inadvertently fall off. However, the weight member could also be provided with a strap, to provide a second attachment means for the weight member, as well as providing a secure attachment.

The counterweight allows for the application of ballast mediated airway protection to enhance surface airway management and promote self sufficiency. The reliable protec-

34

tion of a distressed diver's airway depends on the ballast not changing position in any of the three axis (up, down or around cylinder).

The instant invention achieves many critical features including providing that the weight be permanently attached, so that in an emergency it cannot be dropped. Since the weight member (counterweight) must be small enough to not compromise surface safety, it must be located on the back of the life jacket or on the back of the cylinder exactly opposite the diver where it generates the maximal rotational energy per pound of weight, rotational energy desperately needed to repeatedly turn the unconscious diver over onto their back against minor righting moments caused by limbs, variations in body density, and attached gear. In particular, if the victim is near heavy surf where the waves can flip a victim over onto their face, a strong heads up righting moment is essential. It should be understood that references to a "victim" include, but are not limited to, water accident victims and/or diving accident victims.

The counterweight assembly utilized is responsible for initiating the righting moment, and supplies the rotational energy needed to roll the victim over onto their back thereby assuring that the victim's face will be out of the water regardless of the angle of entry. Once the diver has reached the surface, the counterweight, in conjunction with the dynamics of a limp unconscious body, will oppose any tendency for the waves to roll the victim over into a face down position that would compromise the airway. In summary, the counterweight assembly provides lateral stabilization of the water accident victim or diver (victim), and opposes rotational motion of the waves from over turning the victim into a face down position, but in the event that occurs, the counterweight assembly will automatically flip the victim back over onto their back, reestablishing the heads up orientation.

When an air cylinder is attached to the life vest or buoyancy compensator, the tank compensating counterweight becomes critical. If the victim is lying face down at the surface and goes limp, the counterweight will roll the diver over onto their back, stabilizing the diver's airway out of the water. The size of the weight member selected is in proportion to the type and size of life vest or size of buoyancy compensator and cylinder and whether the water is fresh or salt. The cylinder when empty is neutral to slightly negative, but lacks sufficient rotational energy to roll the victim over onto their back. The counterweight assembly in other words compensates for imbalances in the life vest, buoyancy compensator or the buoyancy shifts of the life vest or buoyancy compensator or the diver's air cylinder. If the cylinder remains negative when empty then the weight member can be smaller but still must generate sufficient angular momentum to offset the secondary righting moments generated by an imbalanced weight belt and attached gear or bladders. If the counterweight assembly is used as an adaption to existing vest style buoyancy compensator, then it has to be strong enough to overcome the side righting movements generated by the common practice of using buoyancy under the arms.

Central to the weight member's design is that it be made of a very dense material such as lead, and be located exactly opposite the diver on the back side of the life vest or the tank. Traditionally the buckle that generates pressure on the belt that attaches the buoyancy compensator to the tank is located in the center at the back of the tank. Because the posterior central position is so critical for the performance of the counterweight assembly, the buckle has to be moved off center. This shift in the cam buckles location results in a

slight inconvenience in terms of reduced access but is necessary to preserve the critical location and therefore the righting moment of the compensating counterweight assembly.

Drowned divers are often found with their weight belts still on. Usually the weights are located along the waist and the amount runs from a couple of pounds to more than forty pounds. As the amount of weight increases, the weight member needs to be located higher up the air cylinder to offset the placement of the weight belt. A dual tank band (providing two weight members) allows for a wide variation of weight placement.

The weight member can also be incorporated into the metal of the cylinder, adhered to the cylinder, enclosed in a covering of any sort, or even attached with magnetism. A pouch or cylinder can be used to contain lead shot or beach sand as long as it is non-releasable and ideally located along the longitudinal axis of the cylinder and thereby serves to generate the heads up righting moment, with the least amount of weight. The various weight member embodiments, described above, guarantee a single surface position every time. That surface position being heads up.

The inclusion of a couple of pounds of weight integrated into the tank band of the buoyancy compensator will allow the diver to overcome numerous minor righting moments that can place the airway of the exhausted or distressed diver under the water leading to drowning, the major cause of death in the sport of diving.

The various counterweight embodiments provide for ballast mediated airway protection, namely, the protection of the diver's airway at water surface level, particularly in an emergency when the diver is unable to protect his or her airway. The various present invention counterweight assemblies reduce the current problem of airway submersion which normally leads to shallow water drowning, the number one cause of recreational diver fatalities.

The attachment of the buoyancy compensator to the tank has always created problems. A cam buckle is provided at the end of the strap to generate tension in the strap. The strap which attaches the tank to the buoyancy compensator, stretches when wet, which can cause the tank to slide down if not out. Thus, the critical ballast compensating counterweight (weight member), in addition to rolling the distressed diver over to protect his or her airway, through increasing the surface area for attachment, serves to markedly improve the attachment of the buoyancy compensator to the tank.

Thus, the present invention illustrates the use or attachment of a relatively small, non-releasable weight, which is applied to a variety of positions along the back of an air tank. The location at the back of the tank allows the size to be reduced to its minimum and still be able to provide reliable airway protection. In warm water the weight is provided relatively lower with respect to the air tank. In cold water where the diver has significant ballast already attached, the weight member is moved relatively higher with respect to the air cylinder towards the head to maintain optimal airway protection. The positioning of the weight member along the back of the tank, optimizes the angular momentum generated per unit of weight. The use of the smallest amount of weight possible to provide airway protection allows the warm water diver, who is by definition already using minimum weight.

With the use of a weight member as described above, from any position a distressed diver can be rolled over onto their back, repeatedly if necessary, with their neck hyper-extended and their airway positioned free and clear. The

distressed diver is provided with ballast mediated airway protection which allows only a single, stable, surface position. Thus, when the diver cannot protect their airway, they can count on their counterweight assembly to act as a self rescue device providing emergency heads up surface flotation. Self rescue requires that at all times throughout the entire dive or underwater travel that the diver's gear is balanced such that their airway will not suddenly become vulnerable to submersion solely because they have become a couple of pounds out of balance in the last minutes of the dive or underwater travel due to the loss of air.

The above described counterweight assemblies roll the diver over, out of his or her side high airway submerging position and onto his or her back when the diver is unconscious. Accordingly, from any position the diver is rolled over onto their back, neck hyper-extended as it drops back, opening the airway. A diver in balance has a single stable airway protective righting moment, while a diver out of balance is susceptible to airway submersion and shallow water drowning.

By it's variable position, high or low, the above-described counterweight assemblies also assists in balancing all of the buoyancy and ballast attached to the diver, creating improved airway support for the distressed diver, from the beginning through the end of their dive or underwater adventure. Diver airway protection is provided regardless of whether the diver's gear is attached or dropped in part or in whole, as may occur in an emergency. The counterweight assemblies are designed to compensate for loss ballast or shift in balance to extend airway protection throughout the dive or underwater travels. Even if the diver is originally face down and unconscious at the surface, the counterweight assembly, when properly positioned tends to almost immediately right the diver face up, thus, protecting the diver's airway should such diver lose consciousness on the surface.

Additionally, a variable displacement device can be provided for providing additional buoyancy to the diver and his or her gear to offset any excess ballast that must be attached to acquire airway protection through ballast mediated airway management as described above.

Some divers, in particular warm water tropical divers, may dive with very little ballast. On occasion, the diver requires a tank mounted ballast that exceeds the amount of ballast needed to submerge. Some reasons why this is required includes (1) diver anatomy (i.e. large "Barrel Chest"); (2) composition of the diver's cylinder (i.e. aluminum); (3) large displacement buoyancy compensator may require up to eighteen (18) to twenty (20) pounds of tank mounted counterweight to provided airway protection yet only require approximately seven (7) pounds to submerge while diving in a bathing suit in warm water; (4) diver wishes to retain the entire amount of releasable ballast so he or she can quickly acquire a net positive surface flotation by dropping his or her weight belt. In such situations the addition of buoyancy will allow the diver to retain his or her releasable weight belt while acquiring the ability to self rescue, as described above, i.e. protect his or her airway from submersion if the diver becomes unconscious. Preferably, the buoyancy added is non-compressible which can occur through the use of a rigid container built into the diver's buoyancy compensator back pack.

Thus, the buoyancy means is attached to the diver/gear to offset the required airway protective tank mounted ballast (weight member). Preferably, the buoyant means is a rigid, non-compressible means for the provision of a specific amount of buoyancy. Other alternative embodiment include

EXHIBIT
Page 42 of 44 pages

5.855.454

37

a closed cell foam. However, with the use of a closed cell foam, as the diver submerges the bubbles in the foam compress, thus, reducing the buoyancy and requiring air to be added to the diver's buoyancy compensator jacket. The added air needs to be vented on ascent.

The buoyancy means preferably has a variable volume to allow for volume adjustments specific to the diver/dive environment. Additionally a single or multiple buoyant means can be provided and arranged to enhance surface flotation attitude.

As seen in FIG. 44, a training device for a tank mounted counter weight member is shown and generally references as device 800. A dive instructor during training, such as pool training, needs to individualize the size and location of the tank mounted counter weight member for each student (diver). To facilitate this time consuming process a longitudinal attachment means 800 is affixed to tank 301 with a quick release coupling means, such as quick side release buckles 802, thus, allowing for rapid attachment and adjustment of size and position of weight member(s) 820 which are housed in sleeve members. Hook and loop fastening means is disposed on at least a portion of the outer surface of the sleeve members for mating with hook and loop fastening strips 804 and 806 associated with training device 800.

The very security that is demanded of the tank mounted counter weight member when used as a life saving means complicates its rapid change and adjustment. As a pool training aid, speed of adjustments is more important than security. As such, training device 800 can be preferably clearly marked with a warning label stating that the device is not to be used for diving.

The vertical tank mounted attachment means can be secured by a wide variety of mechanical means, including, magnetic, zippers, snaps, spring loaded pins, hook and loop fasteners, etc. For example, a fabric jacket having a strip of hook and loop fastening means attached along its length can be provided. Weights in specific sizes can be quickly affixed in combination to establish the correct size, then adjusted vertically to optimize the exact surface flotation position for hyperextension of the diver's neck. The weights are not limited are not limited to any specific, but preferably approximately one (1) or two (2) pounds each.

Training device 800 can be preferably provided with a vertical index 810 which identifies location, such as a measurement means from the bottom of tank 301. Thus, the instructor can inform the student the exact location where the weight member should be attached to tank 301, as well as the exact amount of weight required at such location.

The fabric jacket can also be secured by a wide variety of means. Preferably, hook and loop fastening means is provided to allow the jacket to be easily attached to a wide variety of cylinder diameters. One or more adjustable locking belts can be provided for use with large tank mounted counter weights, which may be required with certain technical buoyancy compensators. The jacket may also be secured by a variety of other means such as belts, buckles, zippers, snaps, etc. Furthermore, the inside coating of the fabric is preferably of a high coefficient of friction to reduce any tendency of the jacket to slip or slide from proper position during adjustment and testing of various tank mounted counter weight member.

FIGS. 45 and 46 illustrate a quick disconnect connector embodiment generally designated as connector 900. Connector 900 generally includes a male member 910 associated with a lifting device 902 and a female member 930 com-

38

monly associated with an inflating hose member of a conventional buoyancy compensator (not shown). Typically, lifting device 902 is deployed at depth. Lifting device 902 can be any type of device which contains a flotation chamber, including, raft 96 shown in FIG. 10. When raft 96 is the intended lifting device, male member 910 replaces a conventional male member 192 (FIG. 10) and which is shown in greater detail as conventional male member 980 (FIG. 47).

With the use of a conventional connector (FIG. 47), male member 980 is provided with a groove member 982 for a locking attachment with female member 930, when the intended lifting device is to be inflated (i.e. emergency situation). Once male member 980 is properly connected to female member 930, an activating member 984 presses a Schrader valve 932 disposed within an internal passageway 934 which extends through female member 930 from its first end 936 to its second end 938. The activation of Schrader valve 932 allows air to flow into the flotation chamber of the lifting device for inflation purposes.

However, with the connection of male member 980 to female member 930, the user (diver) is also attached to the lifting device. Under pressure it is often difficult to release male member 980 from its locking attachment to female member 930. Thus, as the lifting device begins to ascent, the diver (user) is placed in a position of uncontrolled ascent, possibly, leading the diver to one or more of the dangerous conditions described above.

As seen in FIGS. 45 and 46, male member 980 is replaced with a male member 910. Male member 910 includes a first end 912, a second end 914 and an internal passageway 916 extending through said male member 910 from first end 912 to second end 914. Male member is not provided with a groove member to avoid the locking problems described in the previous paragraph. Male member 910 can also be provided with an outer circular flange member 918 and a Schrader valve activating bridge member 920.

In use, male member 910 is received within internal passageway 934 of female member 930 until flange member 918 abuts an outer first end 936 of female member. Thus, flange member 918 acts as a stop means to properly position the first end of male member 910 within internal passageway 934 of female member 930. This positioning of male member 910 with respect to female member 930 allows bridge member 920 to activate Schrader valve 932 to allow air to flow within a flotation chamber of lifting device 902.

Male member 910 is slightly smaller in outer diameter as compared to the inner diameter of internal passageway 934. This allows male member 910 to be snugly and tightly received and maintained within internal passageway 934 of female member 930, while at the same quickly and easily releasable. Lastly, outer flange member 918 also serves as a gripping means to quickly remove male member 910 from within internal passageway 934 of female member 930 once the flotation chamber of lifting device 902 is properly inflated or in the event of an emergency.

The instant invention has been shown and described herein in what is considered to be the most practical and preferred embodiment. It is recognized, however, that departures may be made therefrom within the scope of the invention and that obvious modifications will occur to a person skilled in the art.

What I claim is:

1. A counterweight assembly for providing enhanced heads up surface positioning of a person, said counterweight assembly comprising:

a weight member; and
 means for attaching said weight member to a cylinder, the cylinder adapted to be attached to the person, said weight member attached at a position on said cylinder where the person cannot remove or adjust said weight member while the cylinder is attached to the person; wherein said weight member rotates the person to ensure heads up surface positioning if the person becomes incapacitated.

2. The counterweight assembly of claim 1 wherein said weight member has a body member shaped to be snugly attached the cylinder.

3. The counterweight assembly of claim 2 wherein said means for attaching comprising a tank band inserted through a pair of vertical slots disposed through said body member and wrapped and attached tightly around the cylinder.

4. The counterweight assembly of claim 3 wherein said tank band has non-slide means disposed on an inner portion to prevent said weight means for moving after said weight means has been properly attached to and positioned on the cylinder.

5. The counterweight assembly of claim 2 wherein said means for attaching comprises a strap member inserted through a pair of horizontal slots and wrapped around a cylinder attaching strap associated with a buoyancy compensator to tightly attach said weight member to said cylinder, as well as attaching said cylinder to said buoyancy compensator.

6. The counterweight assembly of claim 1 wherein said means for attaching comprising a tank band inserted through a passageway extending from a first side to a second side of said weight member, said tank band wrapped and attached tightly around the cylinder.

7. The counterweight assembly of claim 6 wherein a plurality of weight members are provided, each of said weight members having a passageway, said tank band is inserted through the passageway of each weight member.

8. The counterweight assembly of claim 1 wherein said means for attaching is a flexible pocket member attached to a tank band, said tank band wrapped and attached tightly around the cylinder, wherein said weight member is disposed within said pocket member.

9. The counterweight assembly of claim 8 wherein said flexible pocket member is permanently attached to said tank band.

10. The counterweight assembly of claim 8 wherein said flexible pocket member is removably attached to said tank band.

11. The counterweight assembly of claim 8 wherein said flexible pocket member is divided into a plurality of weight receiving sections.

12. The counterweight assembly of claim 8 wherein said flexible pocket member has a flap member.

13. A counterweight assembly for providing enhanced heads up surface positioning of a person, said counterweight assembly comprising:
 a weight member; and
 means for attaching said weight member to a cylinder, the cylinder adapted to be attached to the person;
 wherein said weight member rotates the person to ensure heads up surface positioning if the person becomes incapacitated;
 wherein said means for attaching is a flexible pocket member attached to a tank band, said tank band wrapped and attached tightly around the cylinder, wherein said weight member is disposed within said pocket member;
 wherein said flexible pocket member has a flap member;
 and

a releasable pouch member, said pouch member attached to a handle member, said weight member disposed within said pouch member, wherein said handle member is disposed out of said pocket member when properly assembled.

14. A counterweight assembly for providing enhanced heads up surface positioning of a person, said counterweight assembly comprising:
 a ballast member; and
 means for attaching said ballast member in an infinite number of vertical positions with respect to a cylinder adapted to be attached to the person and where said ballast member cannot be released or adjusted by the person while the cylinder is attached to the person;
 wherein said ballast member provides a single reliable heads up position of the person at surface level.

15. A counterweight assembly for a cylinder mounted on a person's body, the cylinder having a longitudinal axis, said counterweight assembly comprising:
 a support member;
 means for adjustably positioning said support along the longitudinal axis of the cylinder;
 a weight member secured to said support member and being disposed substantially parallel to said longitudinal axis, said weight member also secured to said support member where the person cannot release or adjust said weight member while the cylinder is mounted to the person;
 wherein said weight member generates a righting moment to cause an incapacitated person's mouth and nose to be positioned and maintained out of the water at all times.

16. The counterweight assembly of claim 15 wherein said support member is mounted on the cylinder.

17. A non-releasable, securely attached, relatively small amount of tank mounted trim ballast attached in any of an infinite number of vertical positions as required to balance a unique combination of other ballast and buoyancy members attached to and specific to a diver and his or her dive, said tank mounted trim ballast providing a single, reliable, heads up position of the diver at water surface level at any time during the dive, comprising:
 a weight member;
 and means for attaching said weight member to a tank associated with the diver;
 wherein said weight member is positioned such that it cannot be removed or adjusted by the diver during his or her dive or other underwater travel.

18. The trim ballast of claim 17 wherein the non-removable weight member is used in association with separate releasable ballast which may be needed to allow the diver to submerge.

19. A counterweight assembly for providing enhanced heads up surface positioning of a person, said counterweight assembly comprising:
 a weight member; and
 means for attaching said weight member to a cylinder, the cylinder adapted to be attached to the person, said weight member attached at a position on said cylinder where the person cannot remove said weight member while the cylinder is attached to the person;
 wherein said weight member rotates the person to ensure heads up surface positioning if the person becomes incapacitated.

* * * * *

EXHIBIT A
Page 53 of 167 pages

EXHIBIT B

US006530725B1

(12) **United States Patent**
Courtney et al.

(10) **Patent No.:** US 6,530,725 B1
 (45) **Date of Patent:** *Mar. 11, 2003

(54) **WATER SAFETY AND SURVIVAL SYSTEM**

(58) **Field of Search** 405/186, 187;
 441/108, 114, 129

(76) **Inventors:** William L. Courtney, 1990 Hwy. One, Elk, CA (US) 95432; Robert Manuel Carmichael, 940 NW. 1st St., Ft. Lauderdale, FL (US) 33311

(56) **References Cited**

U.S. PATENT DOCUMENTS

(*) **Notice:** This patent issued on a continued prosecution application filed under 37 CFR 1.53(d), and is subject to the twenty year patent term provisions of 35 U.S.C. 154(a)(2).

2,968,159 A	*	1/1961	Edmund	405/186
3,269,129 A	*	8/1966	Zambrano	405/186
4,455,718 A	*	6/1984	Finnem	114/315
5,074,714 A	*	12/1991	Franco	405/186
5,076,575 A	*	12/1991	Eylander	405/186
5,199,820 A	*	4/1993	Nicklo	405/186

* cited by examiner

Subject to any disclaimer, the term of this patent is extended or adjusted under 35 U.S.C. 154(b) by 0 days.

Primary Examiner—Thomas B. Will
Assistant Examiner—Tara L. Mayo
 (74) *Attorney, Agent, or Firm*—Malin, Haley & DiMaggio, P.A.

This patent is subject to a terminal disclaimer.

ABSTRACT

(21) **Appl. No.:** 09/225,892
 (22) **Filed:** Jan. 4, 1999

(57) **ABSTRACT**
 A counterweight assembly is provided to enhance heads up surface positioning of a person. The assembly includes a weight/ballast member strategically disposed on a cylinder/tank worn by a diver during a dive. The weight member can be attached by several different embodiments. Preferably, the weight member is attached such that the diver cannot release or adjust the weight member while he or she is diving. The weight member rotates the person to ensure heads up surface positioning in the event the person becomes incapacitated. Also provided are several other water safety and survival devices.

Related U.S. Application Data

(62) Division of application No. 08/645,206, filed on May 13, 1996, now Pat. No. 5,855,454, which is a continuation-in-part of application No. 08/149,137, filed on Nov. 8, 1993, now Pat. No. 5,516,233, which is a continuation of application No. 07/870,244, filed on Apr. 17, 1992, now abandoned.

(51) **Int. Cl.**⁷ B63C 11/30
 (52) **U.S. Cl.** 405/186; 441/114

12 Claims, 20 Drawing Sheets

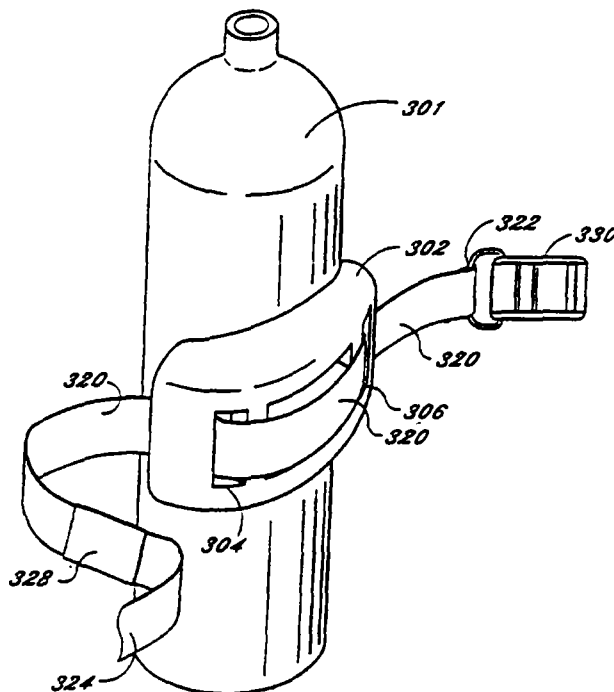

EXHIBIT B
 Page 1 of 41 pages

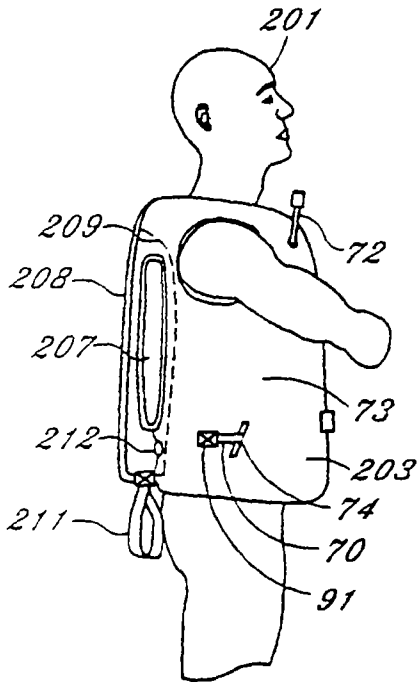

Fig. 1

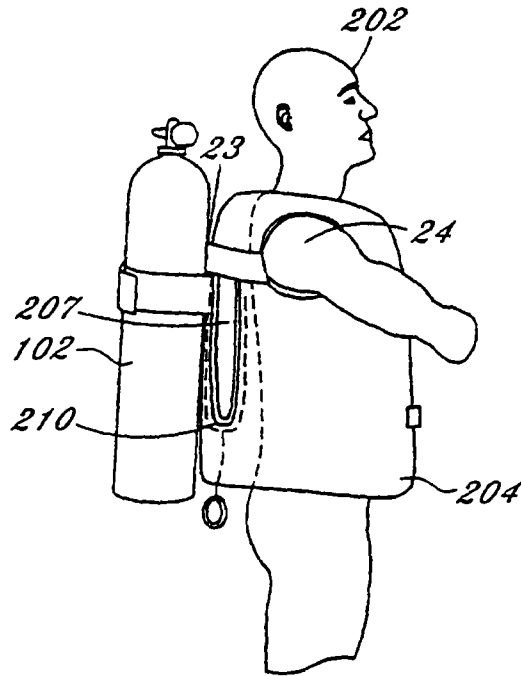

Fig. 2

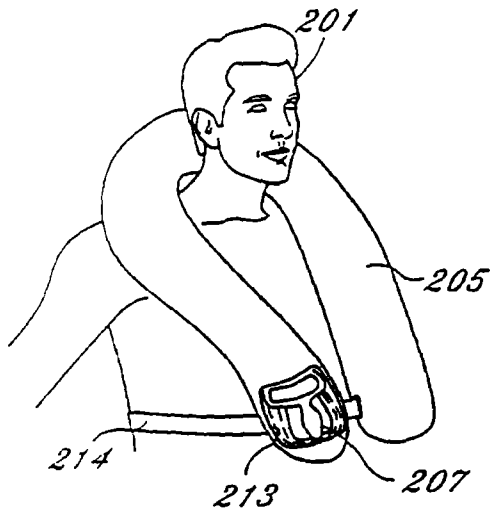

Fig. 3

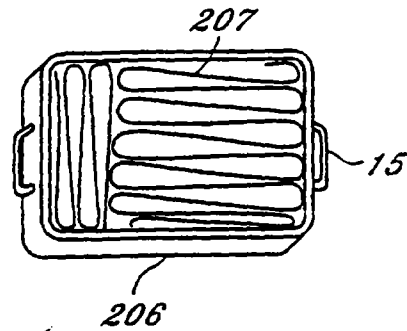

Fig. 4

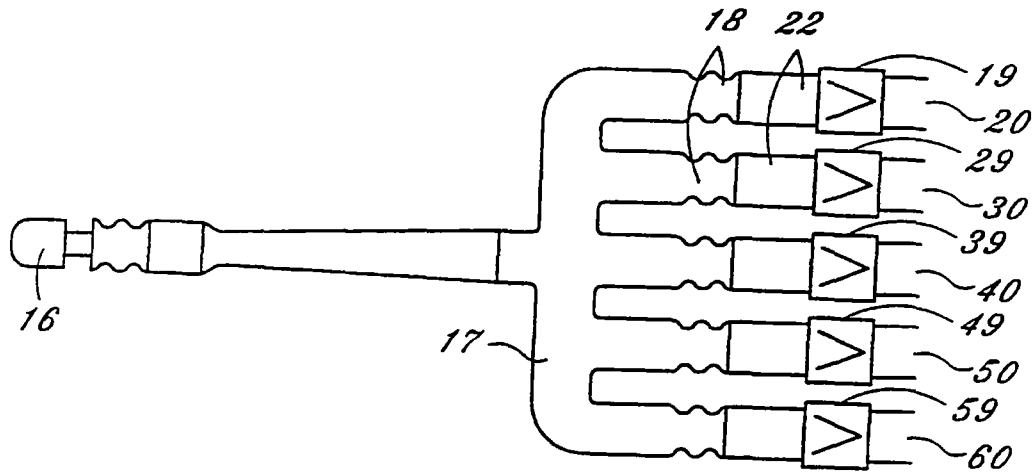

Fig. 5

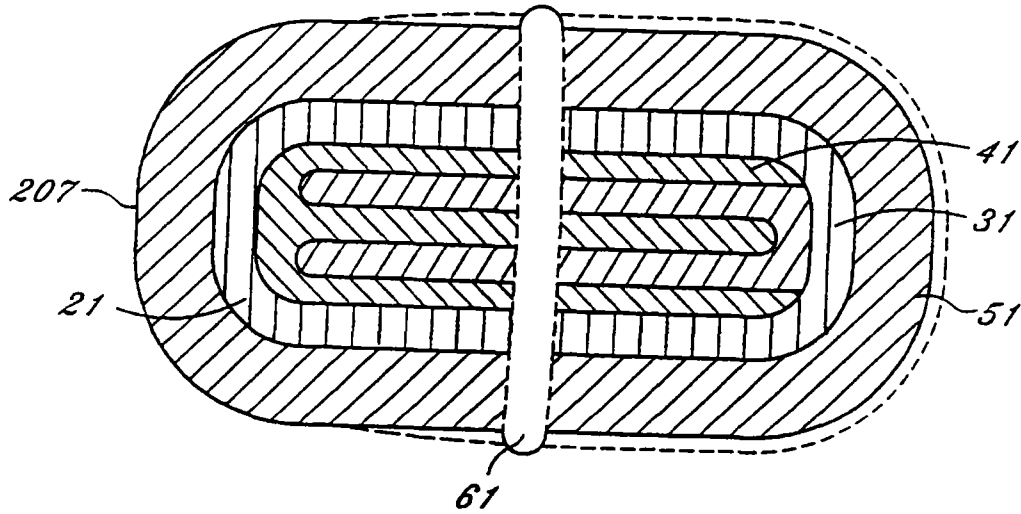

Fig. 6

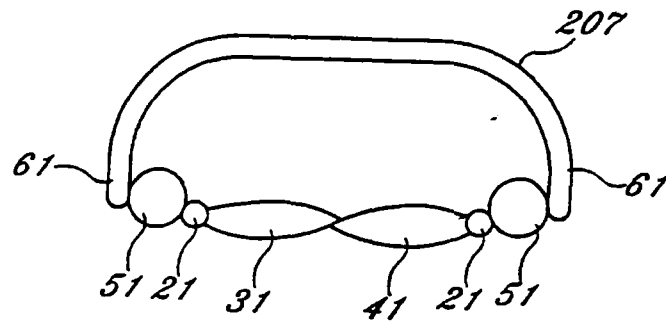

Fig. 7

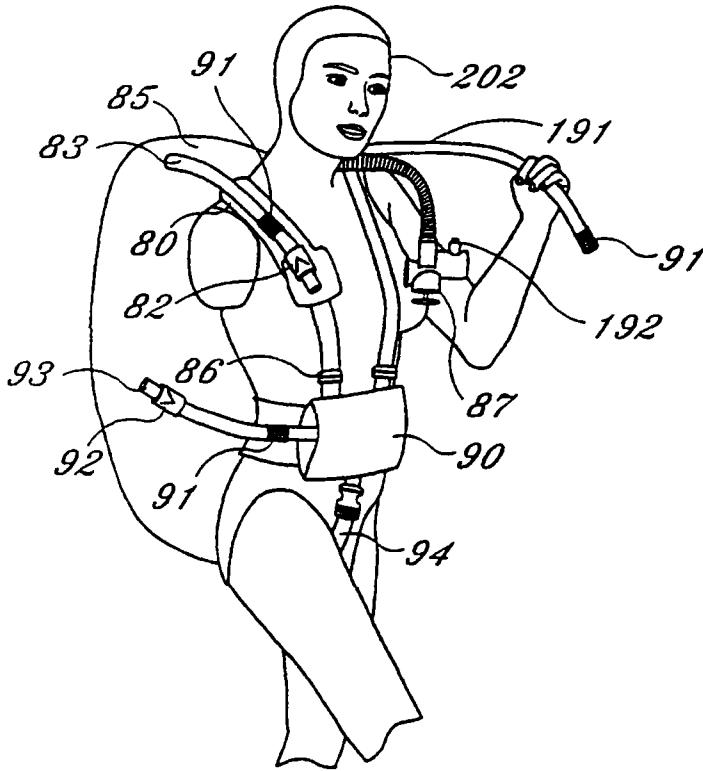

Fig. 8

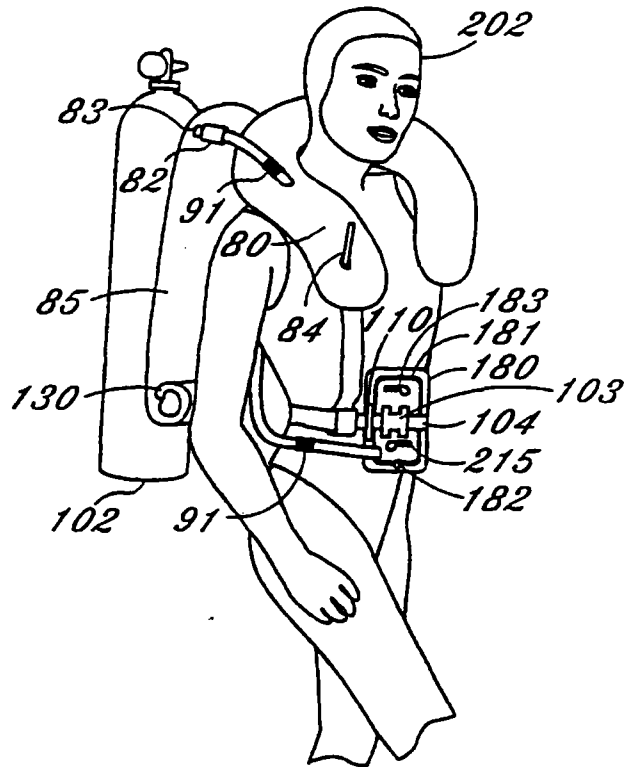

Fig. 9

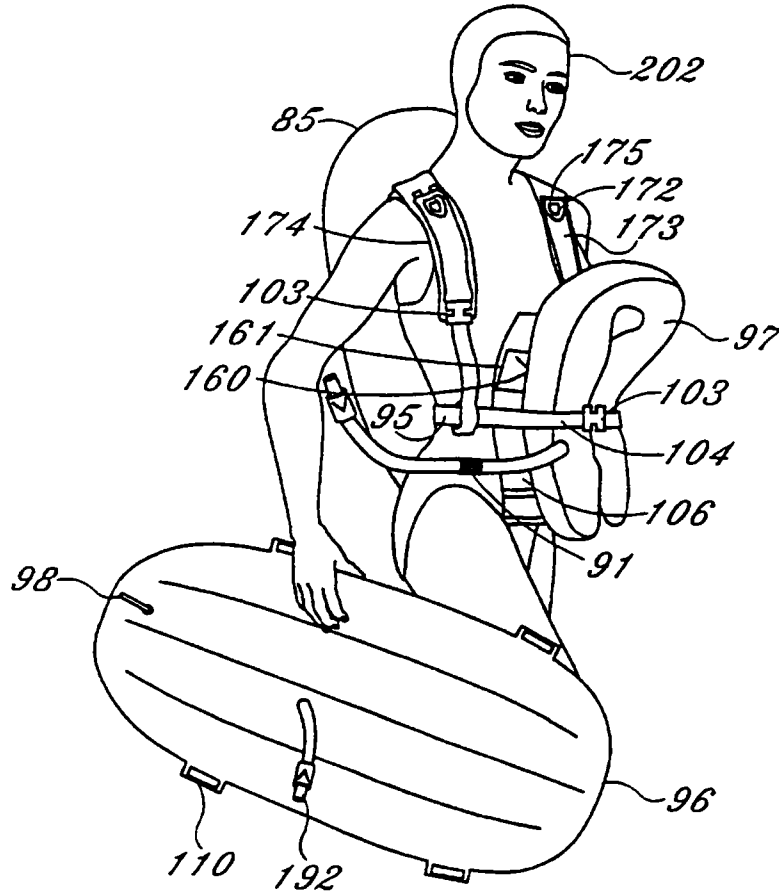

Fig. 10

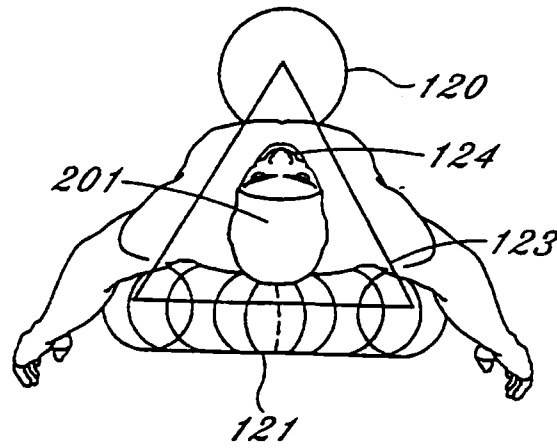

Fig. 11

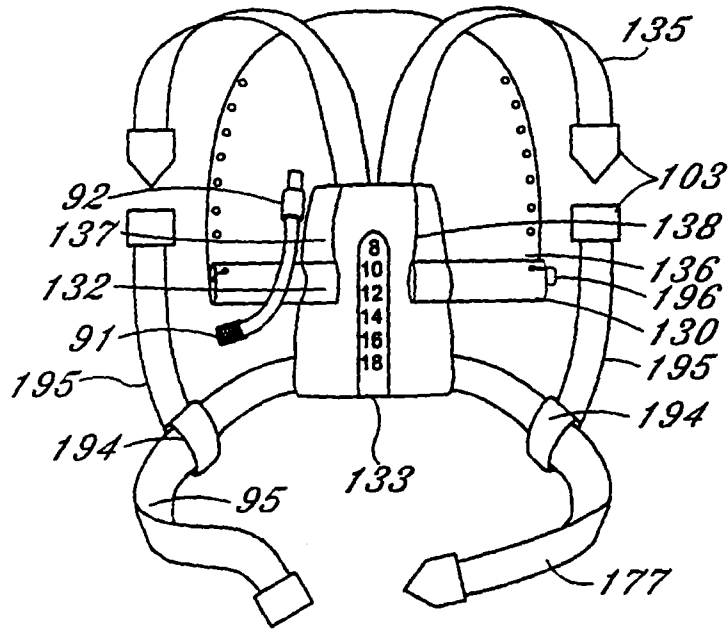

Fig. 13

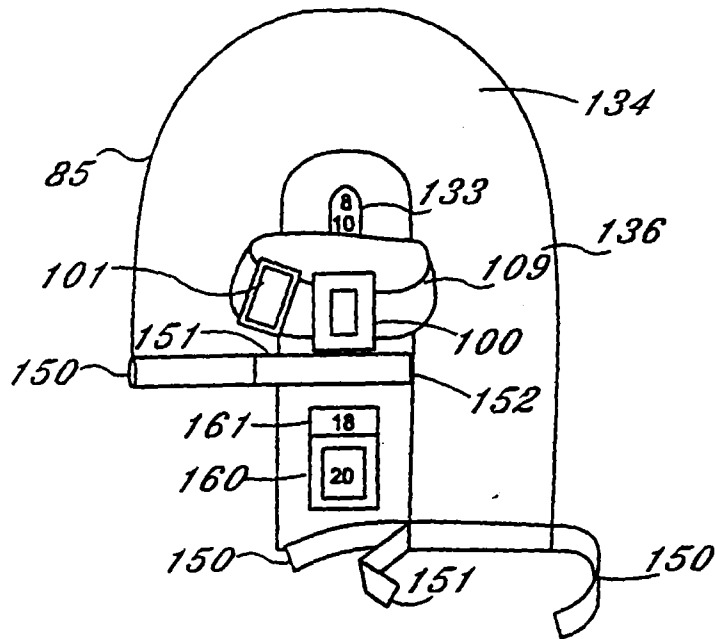
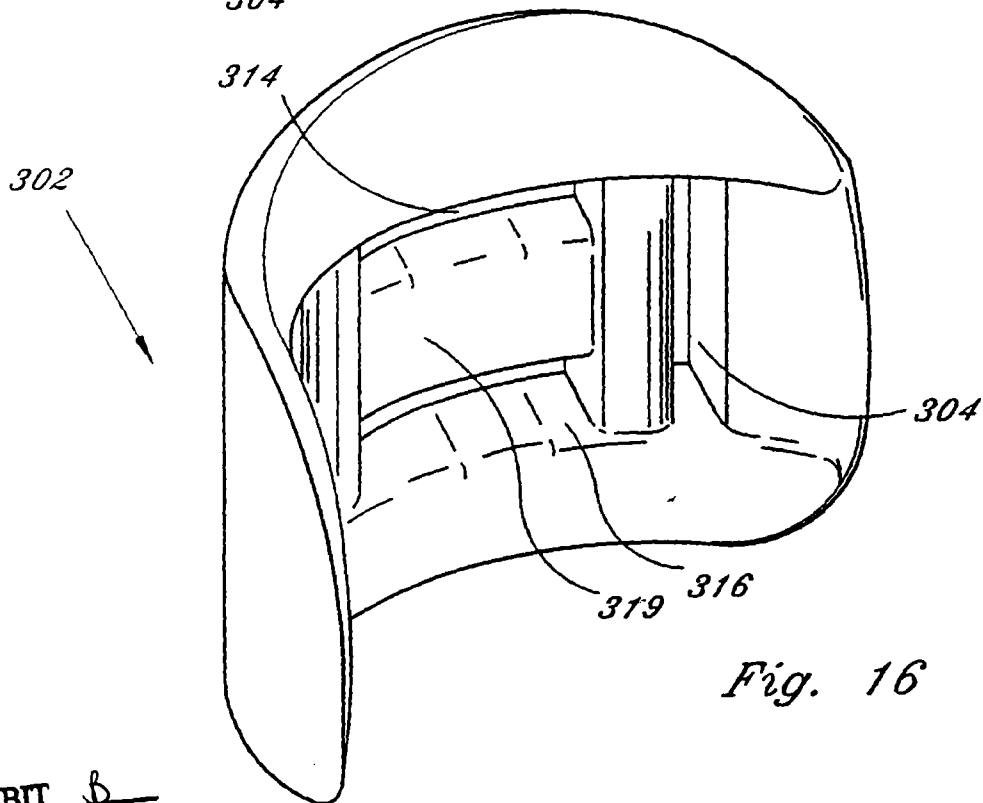
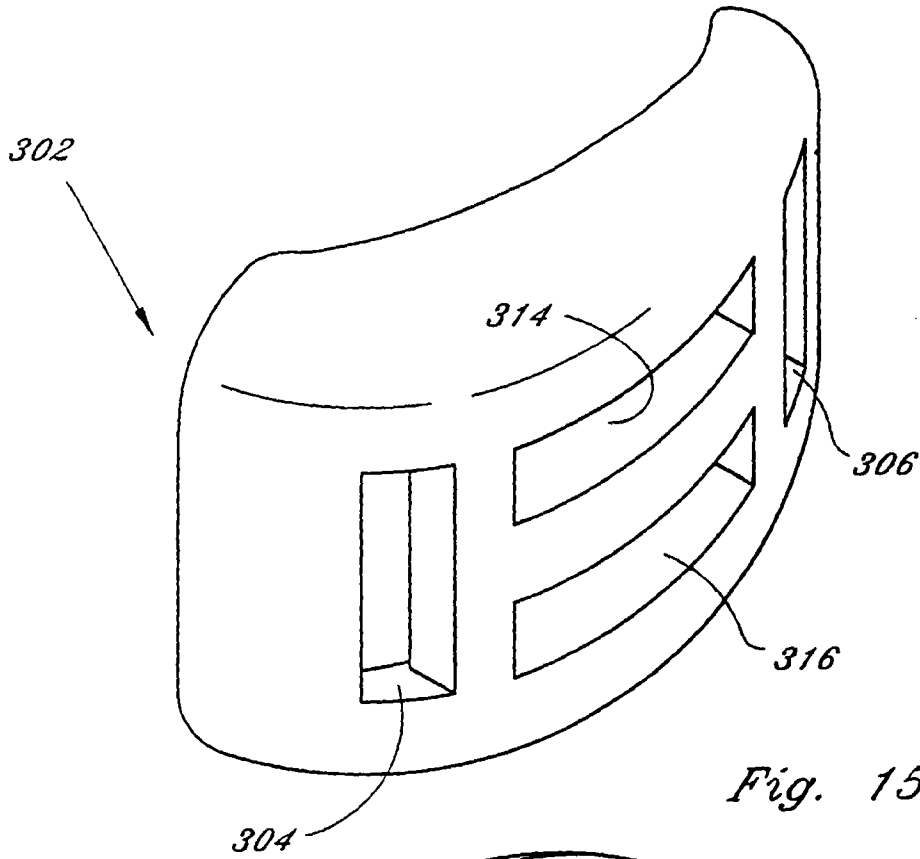

Fig. 14



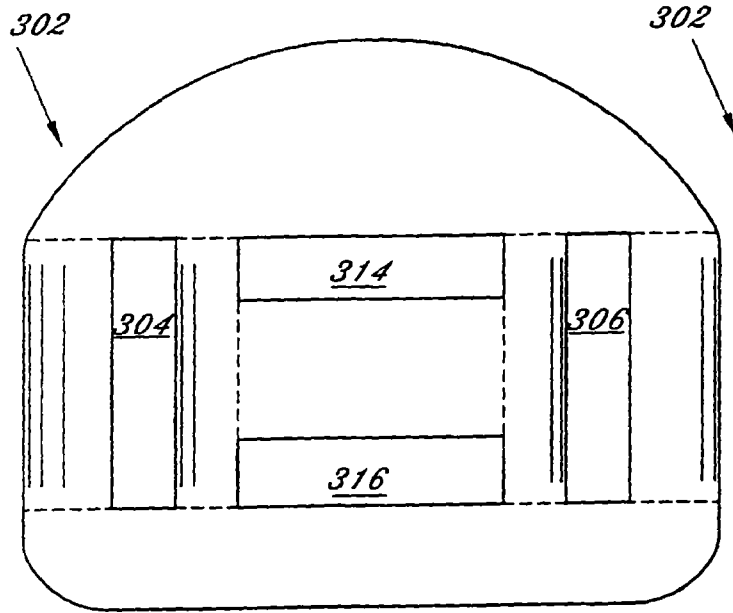

Fig. 17

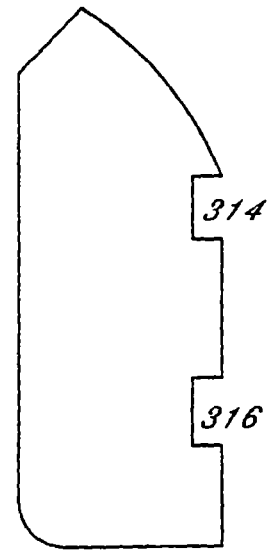

Fig. 19

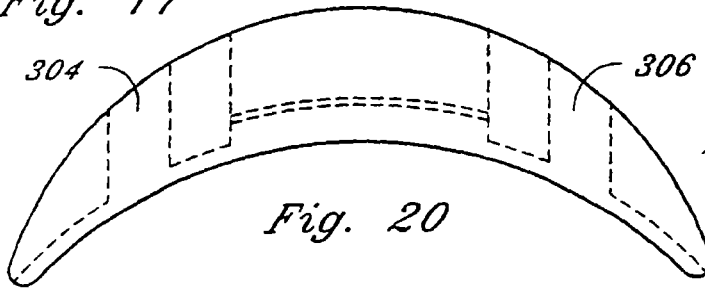

Fig. 20

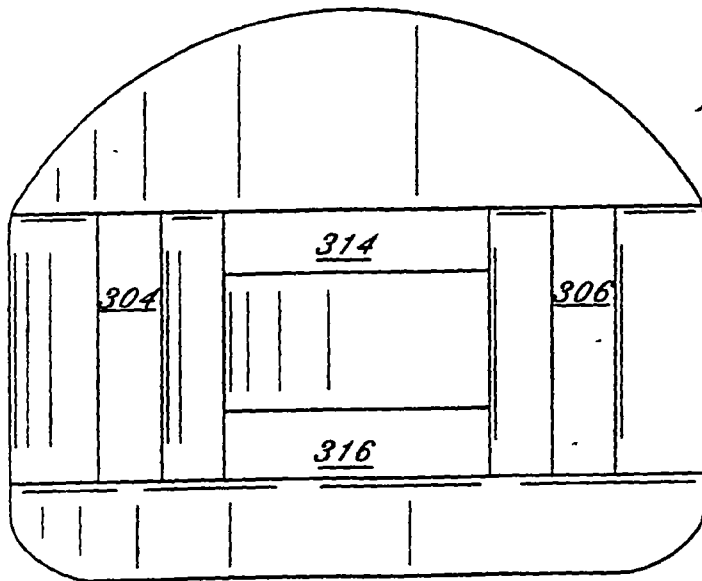

Fig. 18

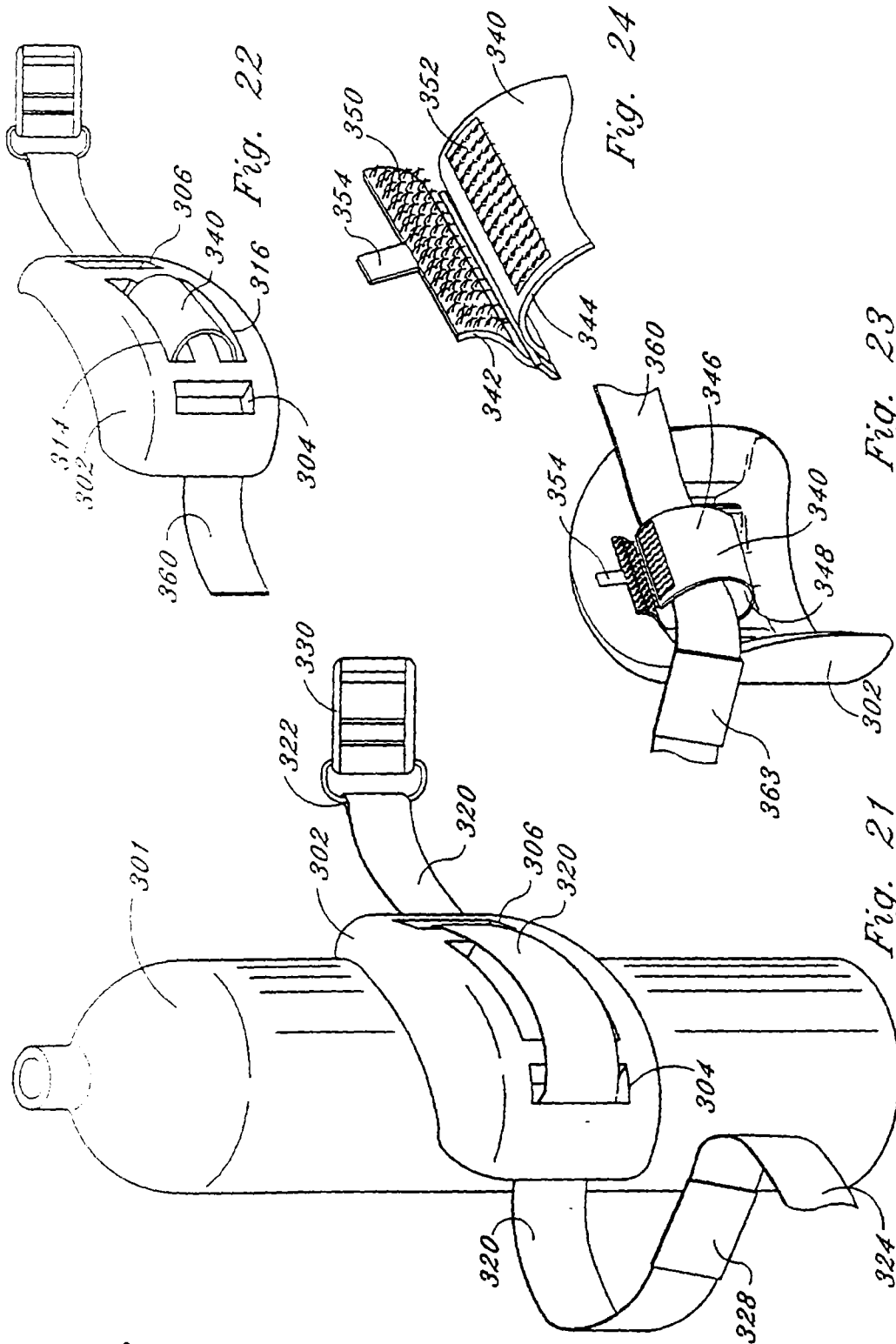

EXHIBIT B
Page 10 of 41 pages

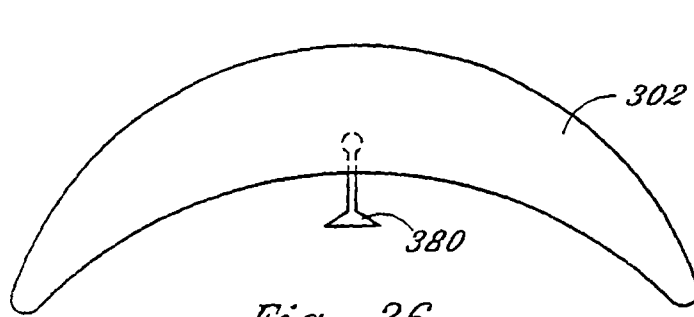

Fig. 26

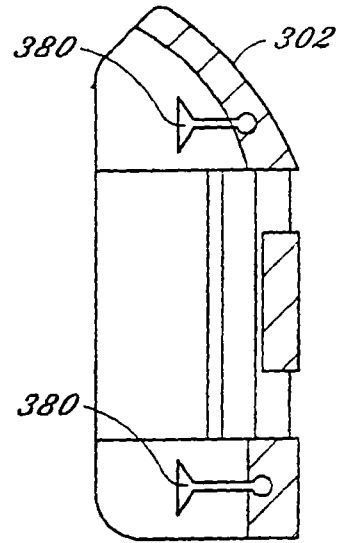

Fig. 27

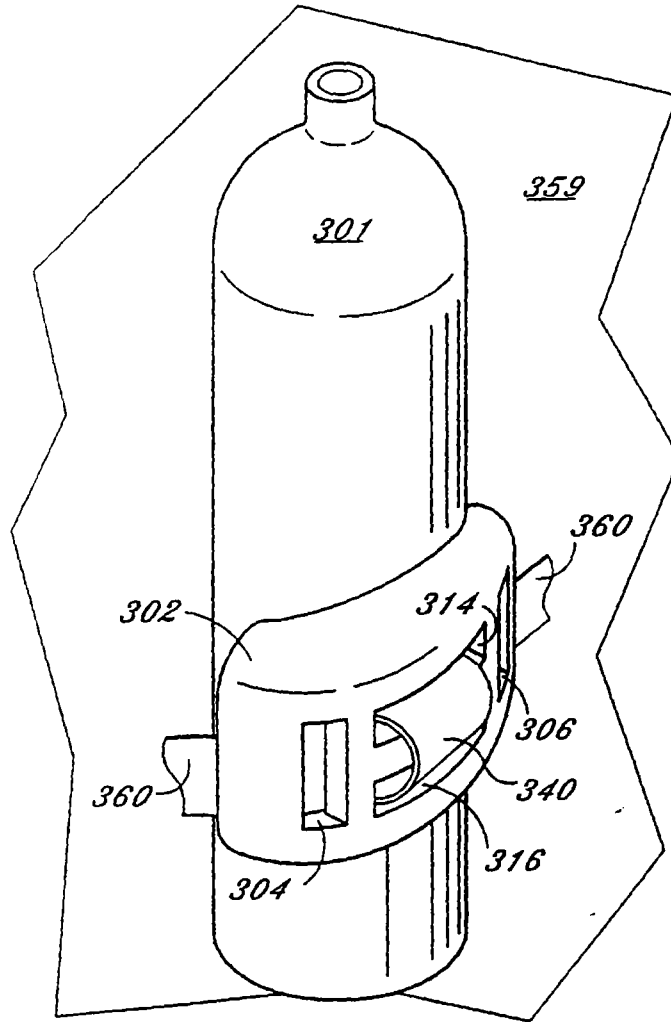

Fig. 25

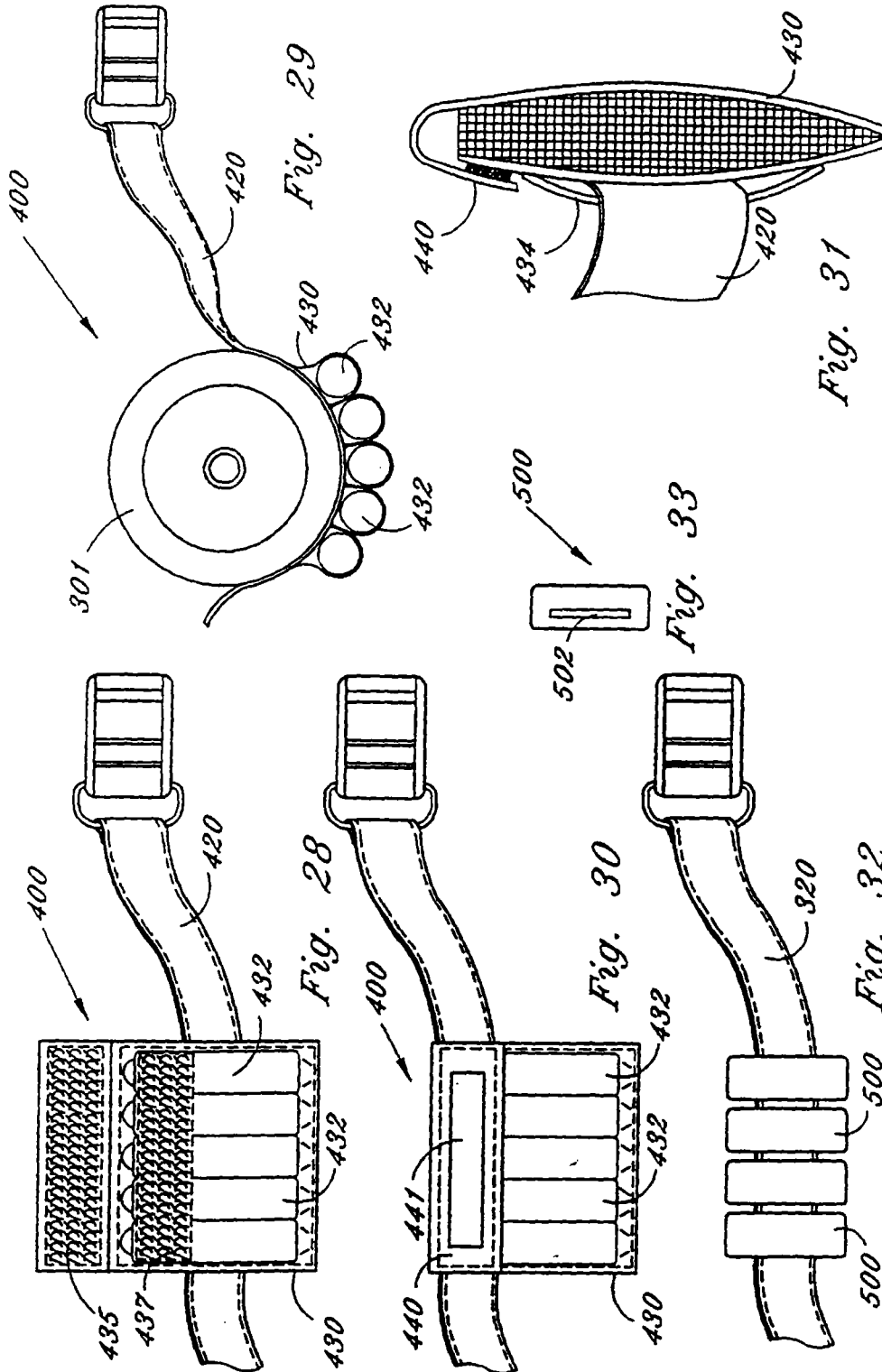
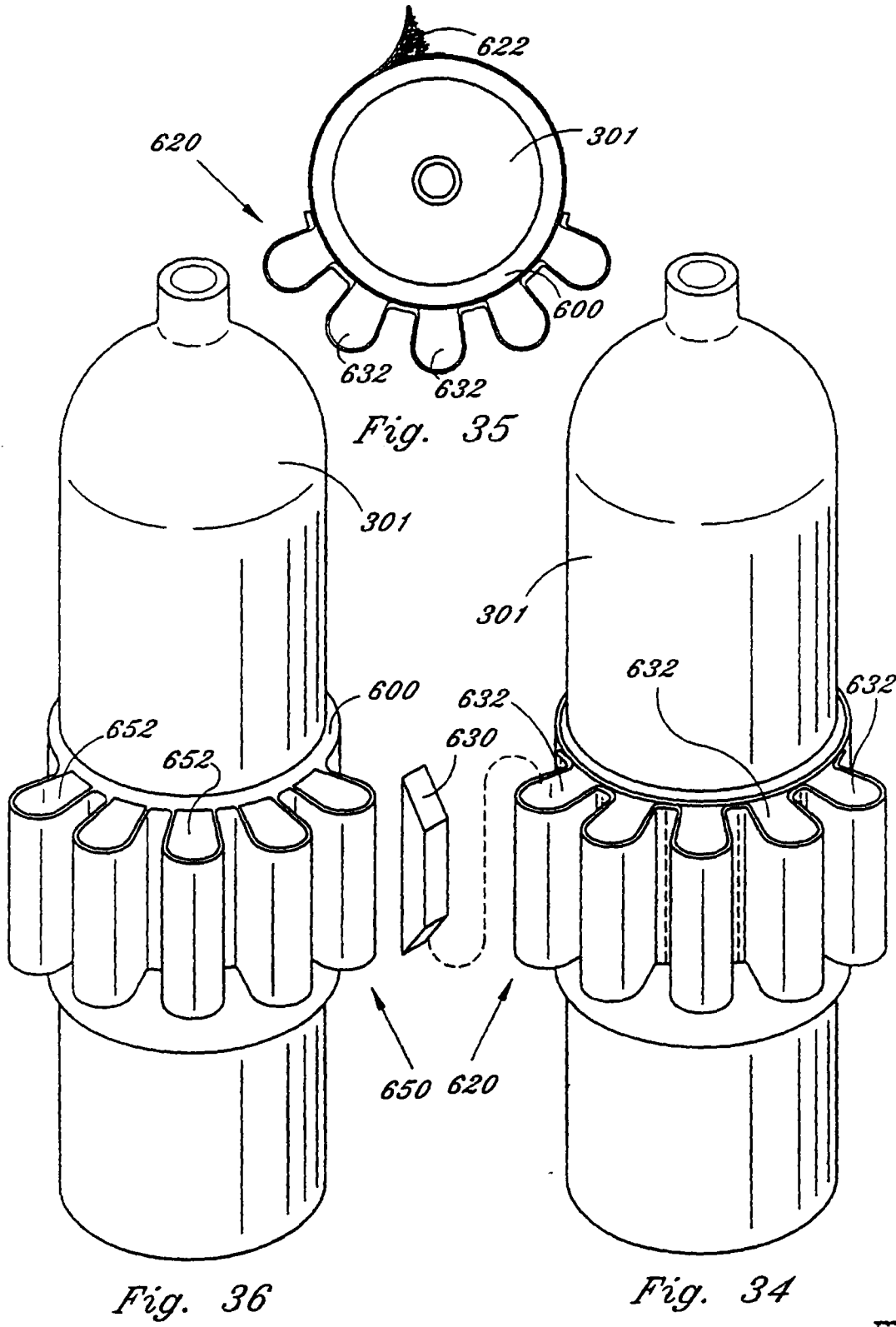

EXHIBIT b
Page 12 of 41 pages



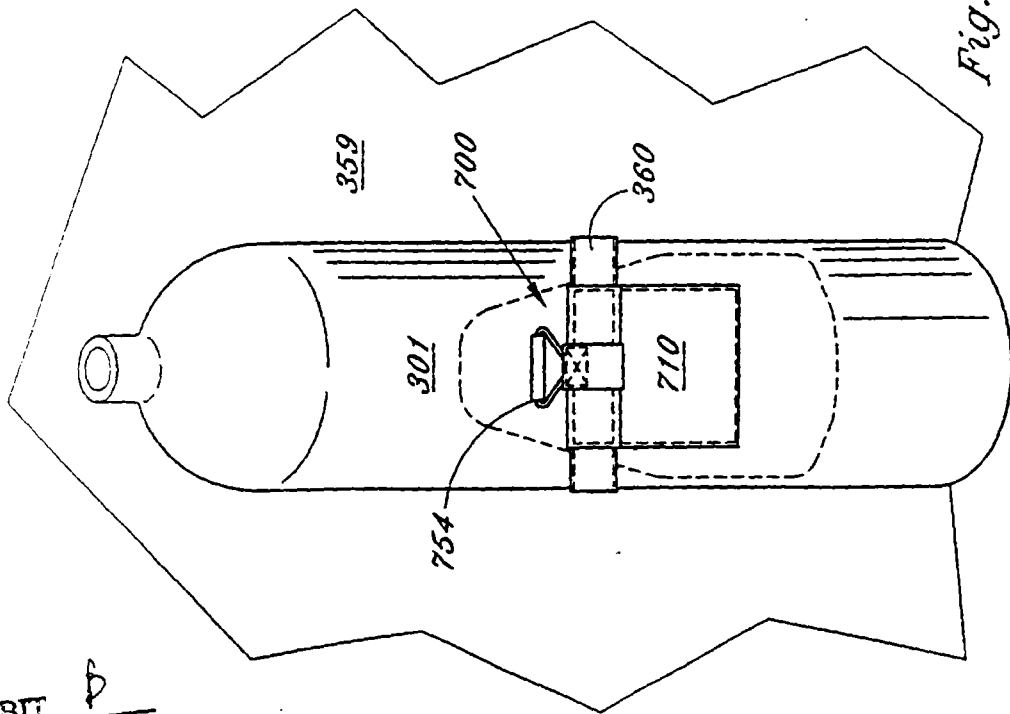

Fig. 37

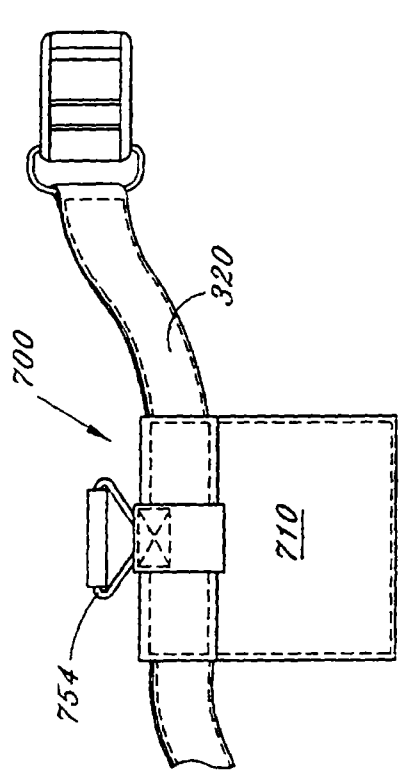

Fig. 38a

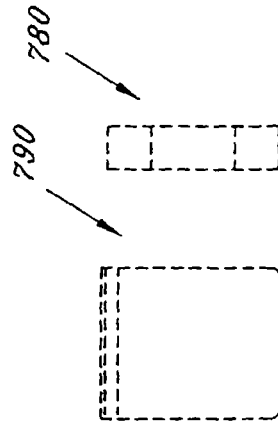

Fig. 38b

Fig. 38c

EXHIBIT D
Page 14 of 41 pages

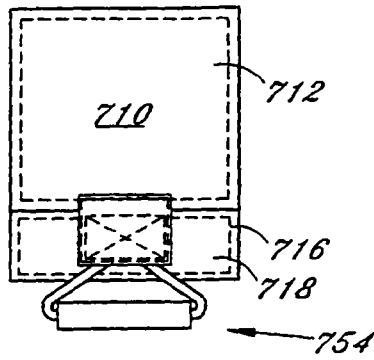

Fig. 39a

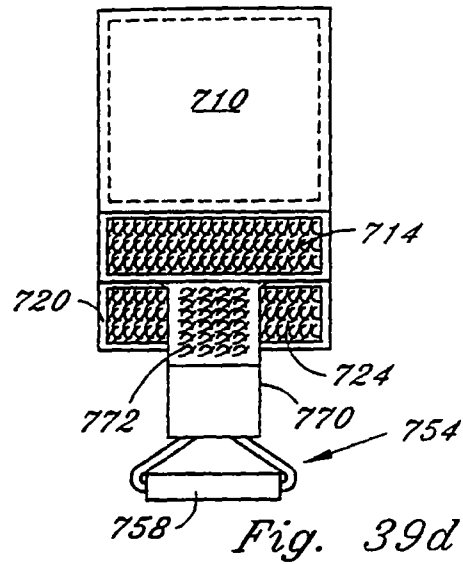

Fig. 39d

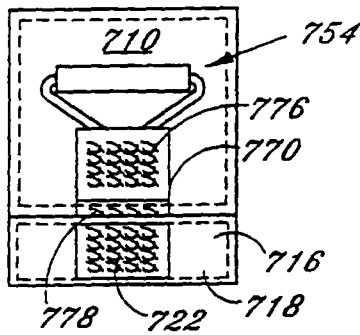

Fig. 39b

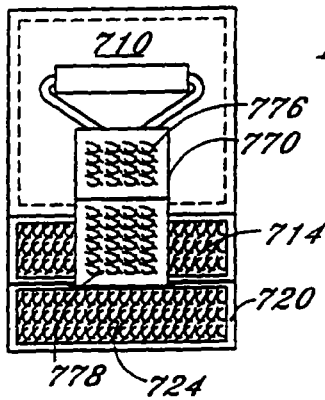
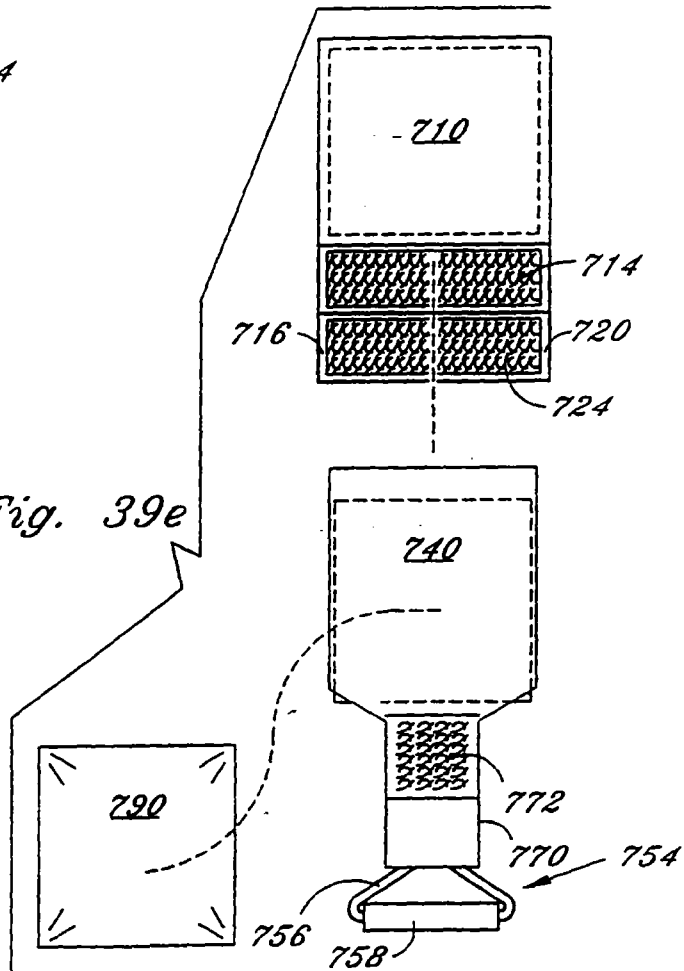
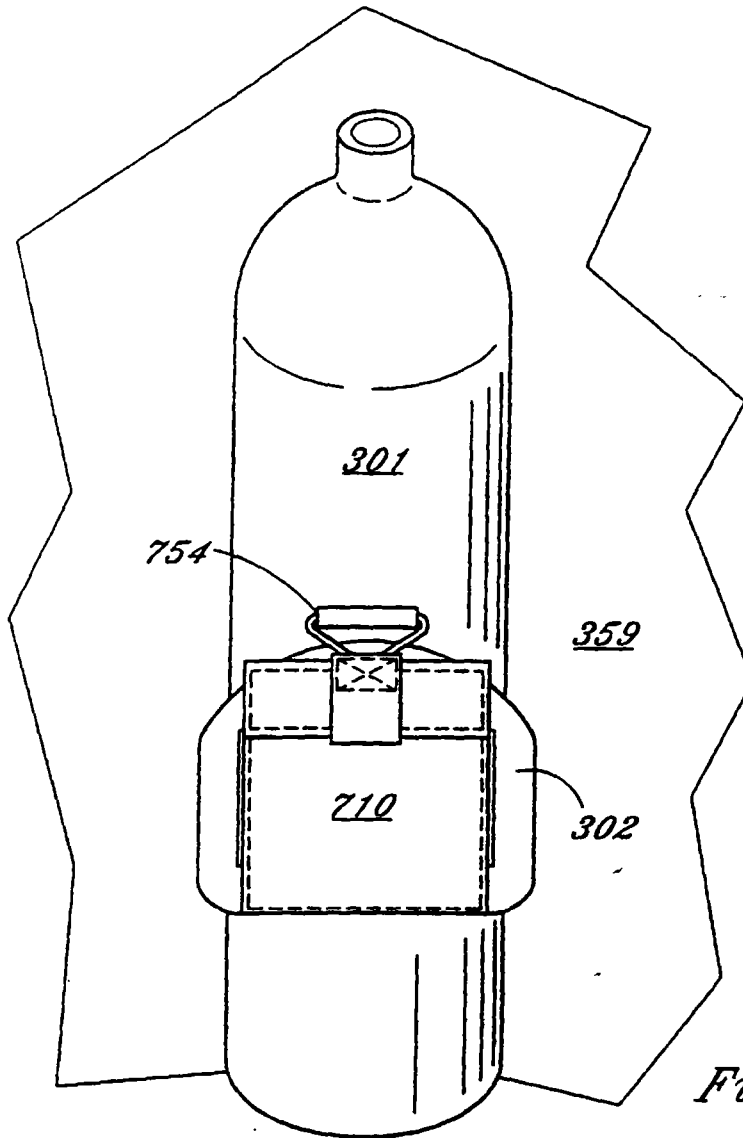
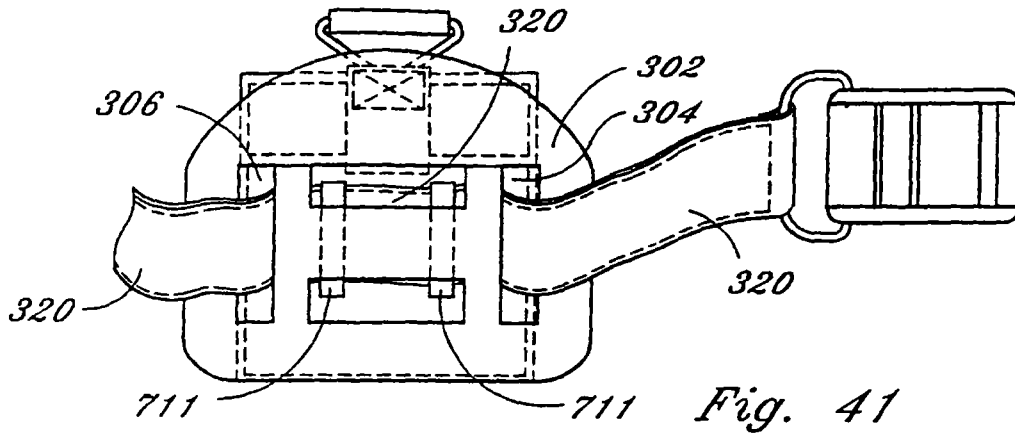

Fig. 39c

Fig. 39e





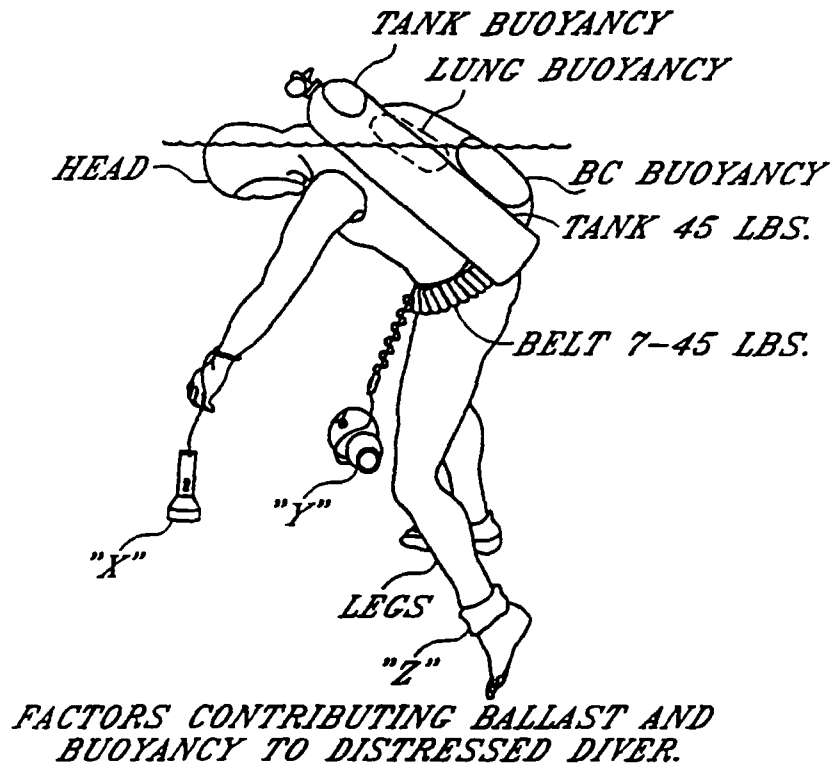

Fig. 42

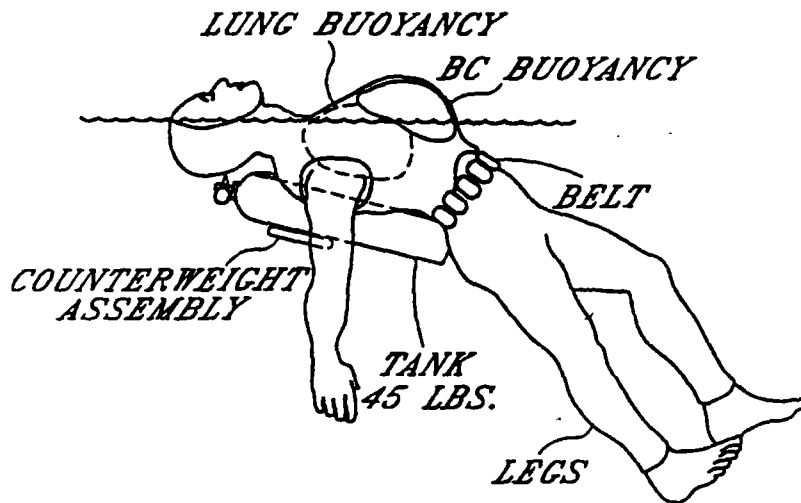
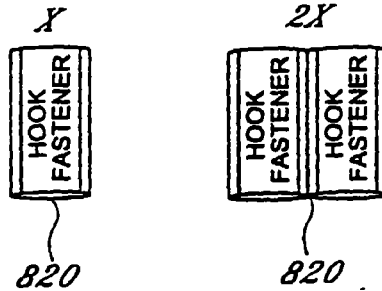
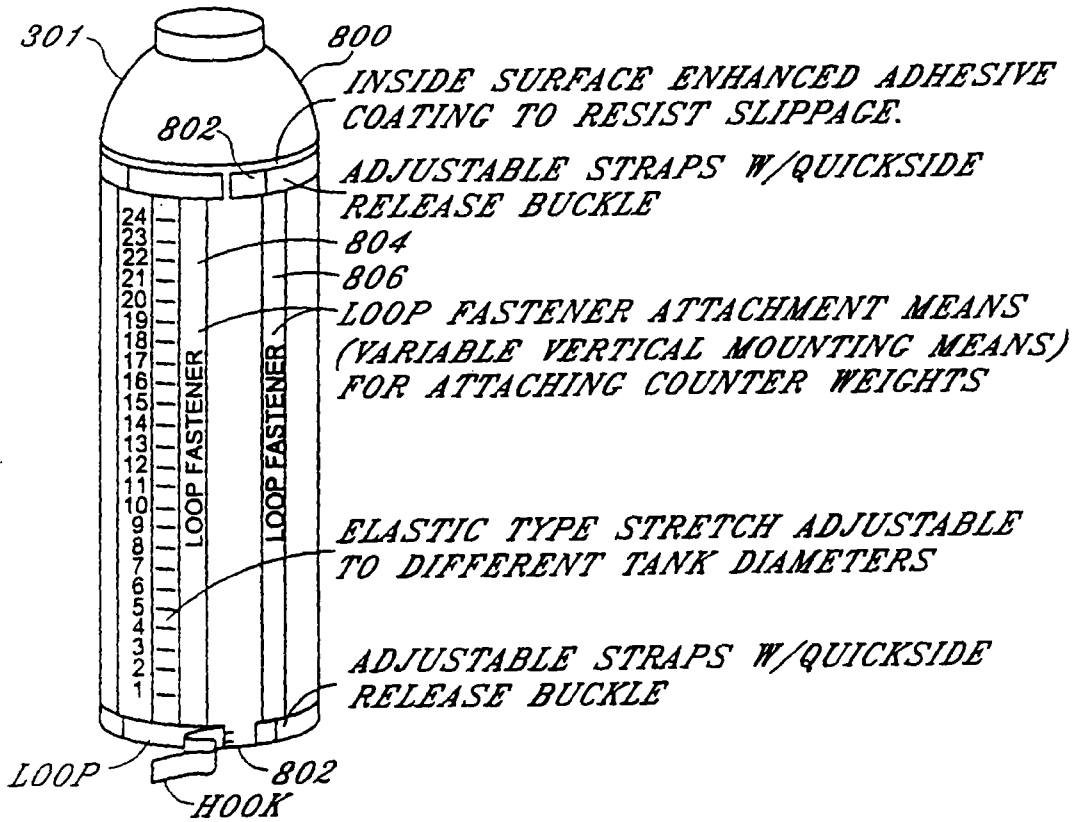

Fig. 43



VARIABLE WEIGHT SIZING W/HOOK FASTENER

Fig. 44

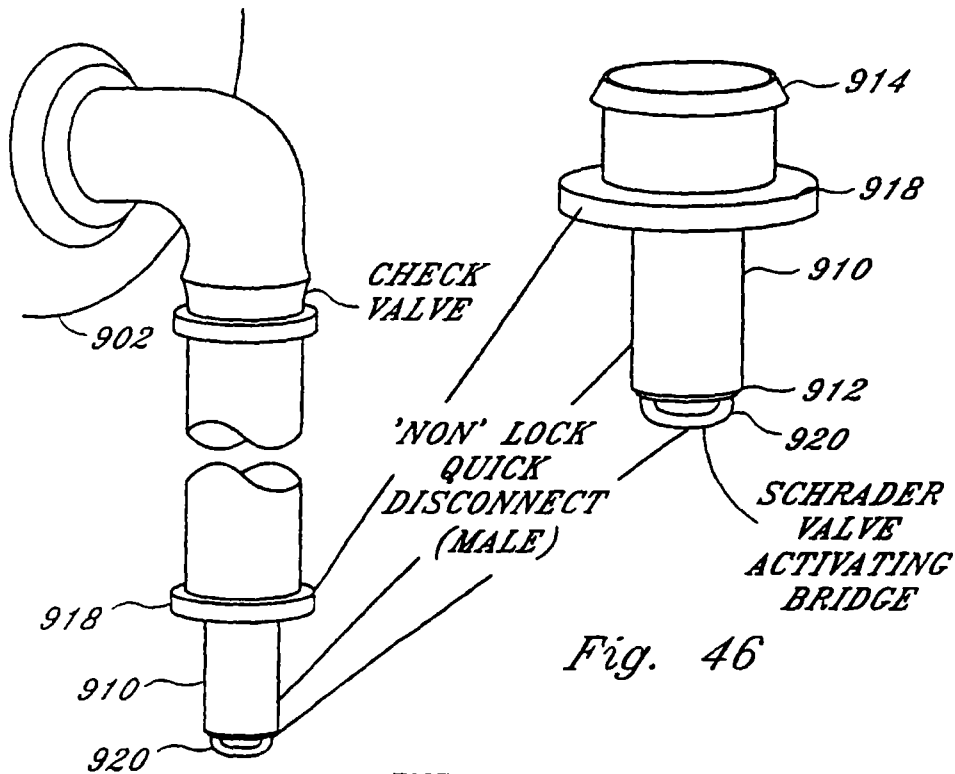

Fig. 46

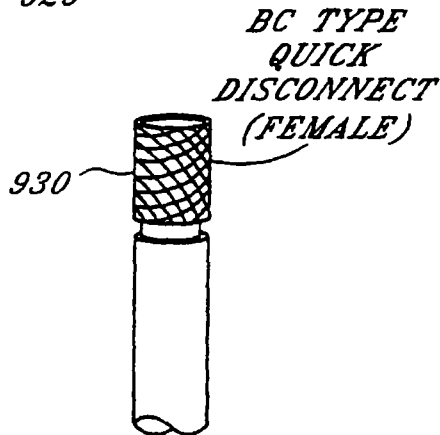

Fig. 45

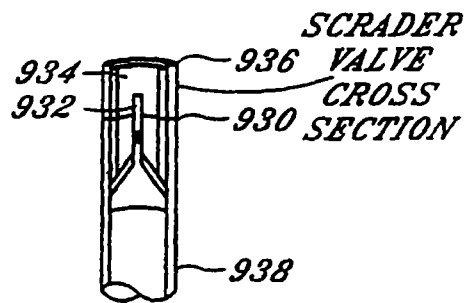
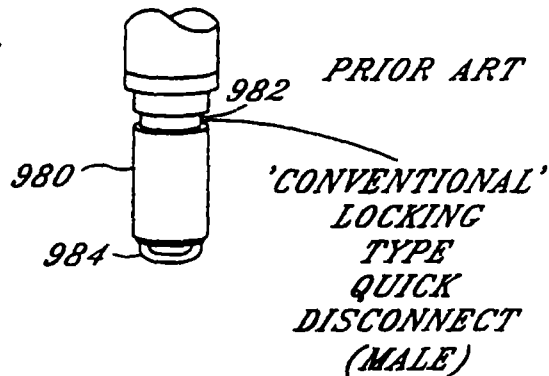

Fig. 47

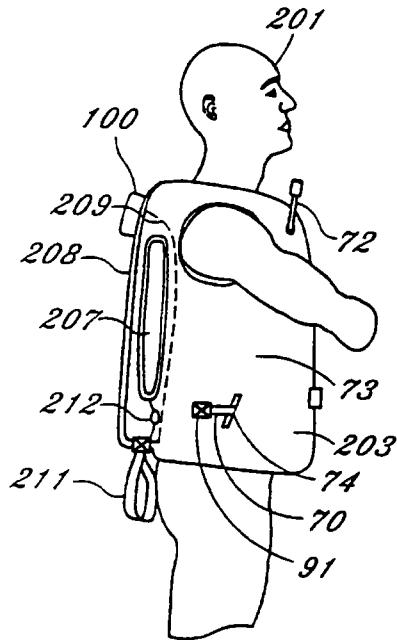

Fig. 48

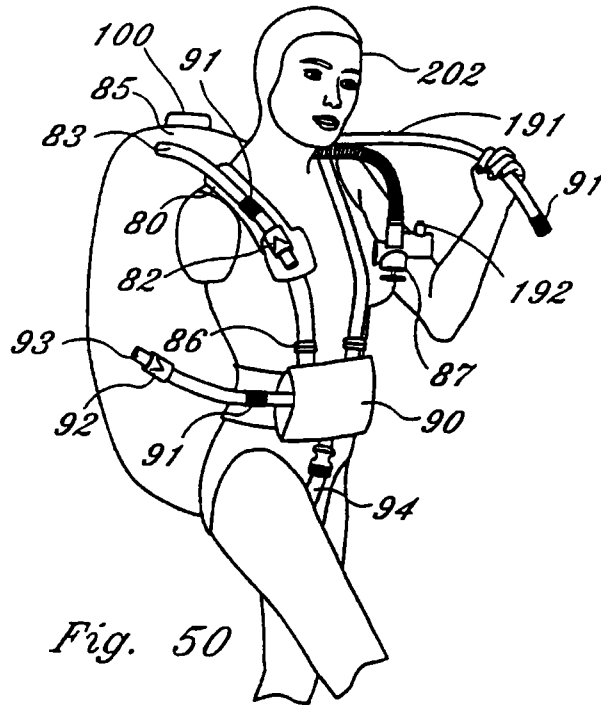

Fig. 50

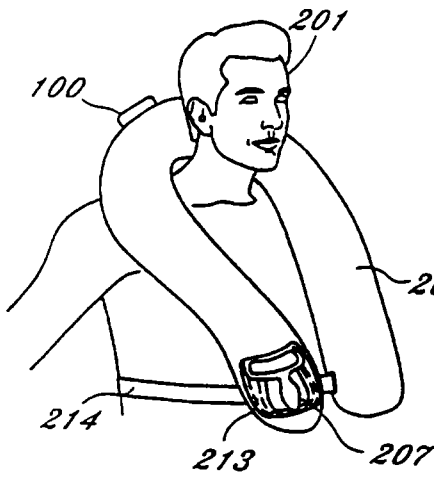

Fig. 49

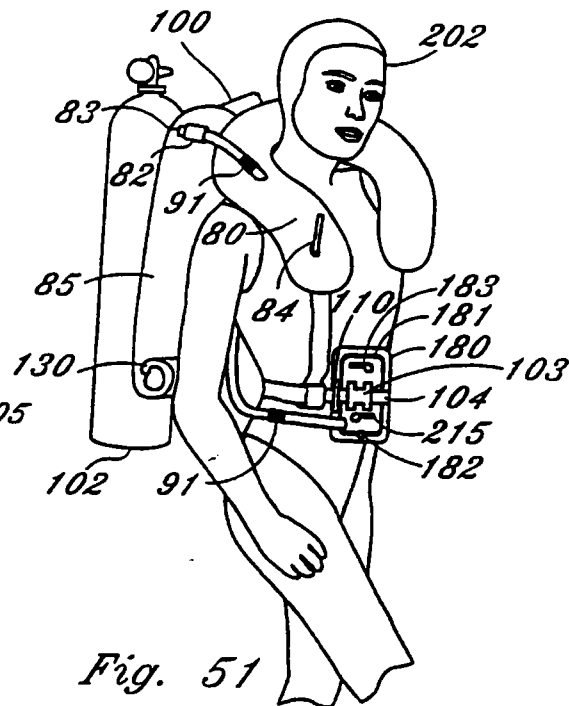

Fig. 51

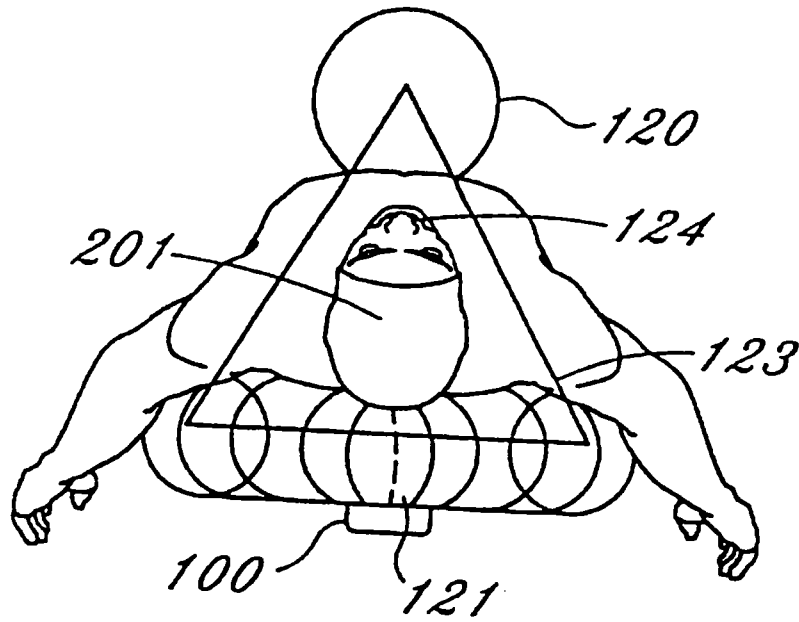

Fig. 52

WATER SAFETY AND SURVIVAL SYSTEM

This Application is a divisional of U.S. patent application Ser. No. 08/645,206, filed May 13, 1996, now U.S. Pat. No. 5,855,454 which is a continuation-in-part of U.S. patent application Ser. No. 08/149,137, filed Nov. 8, 1993, now U.S. Pat. No. 5,516,233, which is a continuation of U.S. patent application Ser. No. 07/870,244, filed Apr. 17, 1992, now abandoned.

BACKGROUND OF THE INVENTION

1. Field of the Invention

The present invention relates to water safety gear including life vests, integrated rescue products, and hypothermic protective gear, adapted for one-time use by the victim placed in the water by accident or for regular use by the water enthusiast whether a sailor or scuba diver.

2. Description of the Prior Art

Heretofore, accidental immersion often resulted in death by two causes, aspiration leading to asphyxiation or hypothermia. A life saving system, to be viable for more than a few minutes, must successfully address both of these issues. Current life vests supply the requisite amount of buoyancy to return the victim to the surface, but often require a conscious victim's involvement to keep the airway clear. While it is common practice, as well as legally mandated, that all civilian, commercial, and non-civilian vessels carry Coast Guard approved life vests, many current water safety products provide only a limited portion of the safety they are capable of providing. They do provide for positive buoyancy during the shock of the initial entry into the water, but by incorporation of the concepts disclosed herein are capable of providing significantly improved airway protection after the initial insult with significantly increased reliability of airway protection and less bulk, cost and, consequently, more compliance.

By force of habit, life vests are currently designed after clothing and as such they open in the middle of the chest, producing a point of reduced buoyancy where it is least acceptable. The division of the forward chamber into two halves produces two side chambers which are each capable of generating righting moments in the water. When a righting moment is created on the body of an exhausted or unconscious individual, they can be stabilized in a face down or side down position. If the left or right side is out of the water, concurrent loss of muscle tone in the neck allows the face, nose, and mouth to be positioned underwater. Thus, current constructions of many life vest are really only adequate for conscious, alert, and active victims because they require participation, constant monitoring and adjustment by the user to keep the face and airway out of the water.

On sudden entry into the water, water on face actuates the Dive Reflex, which is a rapid uncontrollable inhalation. This reflex often results in aspirating water with its consequent choking and coughing. This distress further complicates the victim's ability to right themselves and assist in their own rescue. It is often the case that the sailor who is knocked overboard by the boom of the sail or is swept overboard by a wave, can suffer a temporary loss of consciousness. During this initial interval it is important that their life vest not only buoy them to the surface, but that it also obtain and maintain the victim's face and airway out of the water until consciousness is regained.

The only life vest that is of any value is the life vest that is worn. Compliance can not be ignored as an important criteria in the design and manufacture of any safety product.

The actual use of safety vests has begun to move forward by the hybrid personal flotation devices. The HPFD is a combination of a certain amount of inherently buoyant material along with an additional amount of inflatable buoyancy. Because of the reduced amount of bulk and therefore increased convenience associated with the hpfd, their acceptance is growing. U.S. Pat. No. 4,681,552 issued Jul. 21, 1987 to William Courtney, addresses the value of hybrid personal flotation devices. Like many vest style safety products and in particular all buoyancy compensators, the BC vest described in U.S. Pat. No. 4,681,552, when both chambers are inflated in the configuration disclosed in FIG. 1, would stabilize the user on their side, placing their airway underwater if the user was unable to hold their head up.

The vest that is constructed entirely from inflatable chambers is much more comfortable, convenient and therefore is frequently worn by itself and is now approved by the United States Coast Guard. The purely inflatable product such as the inflatable sailing harness, wind breaker, safety device, because of its compactness, is often the actual product worn by the victim. Many purely inflatable safety products attempt to compensate for the lack of inherent buoyancy by generating large amounts of lift. The use of excessive lift often results in the use of air under the arms where it creates the side up righting moment that can jeopardize the airway, a design defect addressed by the instant invention.

The airlines, because of their insoluble stowage problems are allowed the use of a purely inflatable device that has redundant chambers to guard against the failure problems inherent in single chamber safety devices. The scuba diver also wears a purely inflatable device known as a buoyancy compensator or "BC," which looks like a traditional life vest but because it lacks at least reliability is not called such. The sailor is known to use inflatable wind breakers. All these devices, as well as many not described here, that are meant to provide surface flotation to individuals in the water, would be markedly improved by incorporation of the concepts described herein. Whether constructed solely from inherently buoyant means as are traditional life vests, or constructed from a hybrid composition of inherently buoyant and partially inflatable, or constructed from purely inflatable components, the specific location of a minimal amount of ballast in accordance with the construction herein disclosed would confer dramatic improvements in bulk, cost and compliance and consequently, in safety and survival statistics at sea.

The prior art on the use of dual chambered safety vests includes Swedish patent #203592 issued to Lindqvist on April 1966. This patent discloses a dual chambered product with a large forward chamber which would allow the victim to be stabilized in either a heads up position or if unconscious the victim could be stabilized lying over the forward float with their nose and mouth underwater. The device also relies on the victim's legs to apply tension to a draw string to pull the rear chamber up behind the victim's neck. For the active participant the product may have some utility but would be unsuccessful if not closely regulated. In addition the product is needlessly large and thus unnecessarily bulky when deflated, a feature that often results in the product being stored in a locker rather than being worn.

The buoyancy compensator is a convenience product that has unfortunately replaced the diver's safety vest. The buoyancy compensator is a specific adaptation of a purely inflatable safety product that is worn by the diver for use both at the surface and underwater. The product evolved from the orally inflated safety vest that had the appearance of and was often called a horse collar vest. After decades of

EXHIBIT B
Page 22 of 41 pages

US 6,530,725 B1

3

diving it was decided that the diver would benefit from the inclusion of a chamber to hold air while under water to offset the loss of buoyancy that occurs as the diver's thermal protective gear is compressed at depth. The initial compensators for this shift in buoyancy were containers that could be filled with air to displace water and therefore generate increased buoyancy as the diver's wet suit was compressed by the water. In an emergency this device could be easily disconnected from the diver.

The next step in the evolution of the buoyancy compensator was to use the air cylinder to inflate the safety vest, a product designed to protect the airway at the surface. Its proximity to the face and neck, its obstruction of the chest and therefore the site of controls for the dry suit diver, its general bulk and appearance left room for the advent of the life vest style buoyancy compensator. The initial detached, canister buoyancy compensators were of low volume and easy to ditch. The horse collar and then the life vest style buoyancy compensator became voluminous. The larger lift capacity became equivalent to the better the product. Buoyancy compensators are available with 80 lb. lift capacities. At the surface the high lift product conferred a sense of security because it would buoy the diver far above the water as long as diver remained in firm control of the product. As the diving population became more diverse in health and age, the false sense of security led to marked competitiveness over the amount of lift that could be attached to the diver. The product is so confused with security that a diver can not get onto a dive boat without wearing a high lift buoyancy compensator for "safety" reasons.

The inflatable products worn by scuba divers as disclosed in Greenwood's U.S. Pat. No. 3,436,777; Robert's U.S. Pat. No. 3,747,140; Walters' U.S. Pat. No. 4,016,616; Wright III's U.S. Pat. No. 4,137,585; Scott's U.S. Pat. No. 4,176,418; Maness's U.S. Pat. No. 4,324,234; or Courtney's U.S. Pat. No. 4,645,465 and 4,681,552, and all buoyancy compensators in the prior art are complicated by the attachment of an air cylinder that undergoes shifts in buoyancy throughout each dive as the cylinder empties and becomes more buoyant. The size of the shift in buoyancy is directly proportional to the size of the cylinder used. The nature of the shift in buoyancy, whether the cylinder ends up positively buoyant or only less negative, is a combination of cylinder composition, most commonly aluminum or steel and the water density, fresh, brackish or salt. Some air cylinders become six pounds positively buoyant when empty in sea water. This cylinder will float on its longitudinal axis as will the diver who is attached to that cylinder. Consequently, if for any reason the diver is unconscious, such as from a minor embolism from rapid ascent, blackout, trauma, medical problem or just over exhausted after being stranded at sea, they will eventually lie along side the air cylinder with their airway under the water and statistically the deaths are recorded as drowning. The current management of the life threatening side righting moments of every vest style buoyancy compensator is to disclaim liability for keeping the airway out of the water.

The instant invention discloses the integration of a very small amount of non-releasable weight exactly opposite the diver that converts the only inflatable worn by divers into a product that will protect the airway if the diver is unable to. The attachment of weight to the air cylinder in the prior art has been a way for carrying the ballast necessary for the diver to be able to submerge, and thus were designed to carry significant amounts of weight. Patents issued have turned on the design of the release system. The dive community demands that the attachment of significant amounts of

4

weight must be able to be quickly released by one hand, by either hand. The release mechanism must be sure in that it must not accidentally release, but once the diver chooses to release the ballast the mechanism must be simple enough that it will not fail. All of the prior art by way of its incorporation of reliable release mechanism assures the diver that as an emergency is evolving and their weights are dropped to gain a better surface attitude, the air cylinder that was critical for use under water and is now empty will be attempting to float the diver on their side. If the diver is unable to oppose this action, their nose and mouth will be forcefully submerged.

It is to be noted that in U.S. Pat. No. 4,455,718, the quick release means is positioned centrally to allow access by either hand in the event of an emergency release. Prior to the release, the central positioning of the quick release mechanism necessitates that the weights as demonstrated in FIGS. 1 and 2 and be placed off center, potentially reinforcing the side righting moments of the life vest style buoyancy compensator. The keel retaining system disclosed is built into the buoyancy compensator so it will not be lost or left at home, the buoyancy compensator cannot be safely used without this critical component. In patent U.S. Pat. No. 3,670,509 it is noted that the ballast is located in front of the tank, close to the back of the diver and consequently closer to the axis of rotation which parallels the spine of the diver, thereby drastically reducing the rotational energy generated per unit of keel weight. This greatly reduces the effective strength of the angular rotation generated by a particular amount of ballast. Since some divers in the tropics may dive with only a few pounds of weight, it is important that the keel weight be kept as far away from the axis of rotation as is possible to maximize the strength of the righting moment. The critical location is on the exact opposite side of the tank from the diver. U.S. Pat. No. 3,670,509 refers to "substantial reducing" the tendency to force the diver face into the water. Use of the disclosed improvements will not allow the face to remain underwater. The ballast in patent U.S. Pat. No. 3,670,509 that attempts to reduce the face down righting moment, positions the diver so that they are able to "... activate the weight release mechanism.", with the loss of the ballast the diver then would be back to floating on their side with their airway underwater. U.S. Pat. No. 3,967,459 locates the weight system inferior and adjacent to the diver nearly the exact opposite as disclosed herein. It is also noted that this weight system is intended to be released in an emergency reestablishing the tendency of the cylinder to submerge the diver's airway. The integrated ballast system of U.S. Pat. No. 4,752,263 is similar in that it is releasable, and located inferior and adjacent to the diver allowing for an airway endangering surface position. The ballast system disclosed in U.S. Pat. No. 2,120,420 places weight symmetrically about the diver which would totally eliminate any heads up righting moment and in fact would stabilize the diver 50% of the time in a face down position. Additionally, this system is not designed to be used with an air cylinder, but rather a surface supply air system.

The instant invention achieves many critical features including providing that the weight be permanently attached, so that in an emergency it cannot be dropped. Since the keel weight must be small enough to not compromise surface safety, it must be located on the cylinder exactly opposite the diver where it generates the maximal rotational energy per pound of keel, rotational energy desperately needed to repeatedly turn the unconscious diver over onto their back against minor righting moments caused by limbs, variations in body density, and attached gear. In particular,

EXHIBIT
B
Page 77 of 11 pages

if the victim dives near heavy surf where the waves can flip a victim over onto their face, a strong heads up righting moment is essential.

Another critical problem with the use of all current buoyancy compensators is that they combine high lift surface flotation needs with low lift underwater buoyancy needs. That same device at depth entraps pressurized air by design. The 190 lb. diver at 120 feet underwater requires nine pounds of air in their buoyancy compensator due to compression of their cold water wet suit, should that diver begin an uncontrolled ascent because; their regulator malfunctions, their tank is empty, they lose their mask and become disoriented, the power inflator sticks on their buoyancy compensators, they suffer a minor medical problems as they attempt an emergency ascent, for whatever the reason, as the diver ascends, the air in their buoyancy compensator begins to expand. Ten pounds of air at 99 feet underwater, increases to 13.3 pounds at 66 feet and increases to twenty pounds at 33 feet and doubles forty pounds during the last 33 feet of the water column, enough air to create excessively fast ascent rates.

Recommended safe ascent rates are in the process of being reduced from 60 feet per minute to 20-30 feet per minute. A buoyancy compensator that can contain 30 lbs. of air can accelerate a diver who is stationary less than 10 feet underwater to the surface at average velocities over the last 4 feet, in excess of 200 to 250 feet per minute. Ascent rates from greater depths or ascent rates with larger buoyancy compensators such as currently available products generating 40, 60 or 80 lbs. of lift are unknown. It is known that if a person's lungs are fully inflated and they hold their breath while ascending three and a half (3½) or four (4) feet, their lungs will rupture. Pulmonary barotrauma introduces air into the circulation where it can obstruct circulation and result in infarction of the tissue involved. Since the diver is often vertical during an uncontrolled rapid ascent, the embolism most often travels to the brain. Unless the diver is re-compressed within minutes damage is permanent and possibly fatal. The prior art on buoyancy compensators, as is practiced in the diving community, unfortunately combines low lift buoyancy compensation needs with high lift surface flotation. The prior art buoyancy compensator is in desperate need of the many advances disclosed herein.

Once the conscious or unconscious individual is supported safely at the surface with their airway free and clear, the next major threat to the water borne victim whether recently returned from the depths or a survivor of a common carrier accident such as an airplane crash, is from; not being seen by search and rescue efforts, of being drowned while attempting a rescue or from hypothermia.

The rapid lowering of the body's core temperature results in interruption of life sustaining cognitive activities such as staying in a tucked fetal position, which further aggravates heat loss. With the loss of cognition the victim stops monitoring and responding to changing surface conditions. Inevitably hypothermia interferes in brain stem activities such as musculoskeletal tone and respiration. It is widely known that hypothermia is the actual killer in most accidental immersions. In response to such knowledge, exposure suits have been developed to insulate individuals and preserve core temperature thus extending survival from minutes to hours. An effective exposure suit is a large, bulky item that is prohibitively expensive. Despite these serious drawbacks it is the only alternative to dying from hypothermia within minutes and as such it is a legally mandated safety device for the industrial sector where its costs, bulk and inconveniences can be borne. Exposure suit costs and bulk have

prevented their use being required in the recreational, civilian or commercial carrier sectors such as airlines, liners, ferries etc. Therefore it is clear that despite recognition that hypothermia is the active process in death at sea, there has not existed until this time a viable, affordable, storable means to control hypothermia.

To address this deficiency in the prior art, the current invention addresses both aspects of safety at sea. Rescue can rarely be performed within minutes. Often the sailor on watch is not missed until the next watch, obviously the single handed sailor is never missed. The sinking of a civilian or commercial carrier is often unattended for many hours or longer. As is noted in Harrigan's U.S. Pat. No. 2,114,301; Bennett's U.S. Pat. No. 3,105,981; or DeSimone's U.S. Pat. No. 4,187,570, there exists complex, bulky and costly means whereby jet pilots and navy personnel have personal power inflated life rafts. These automatically inflated life rafts require a cylinder whose cost alone is prohibitive to private and commercial carriers. The bulk of the cylinder, the bulk of the raft constructed from a fabric capable of withstanding pressurized inflation and high impact forces results in a device that is incompatible with civilian and commercial carriers such as airlines or ferries, yet alone individuals wind surfing, fishing from rubber rafts or touring ocean kayaks.

SUMMARY OF THE INVENTION

The smallest safety vest that reliably protects the victim's airway is ideal because of its lower cost, reduced bulk when deflated, and improved appearance. all factors that contribute to compliance with use, the true basis of success in any emergency. The current water safety vest distinguishes the two critical points of buoyancy, one behind the neck and head with the second point of buoyancy being in the area of the umbilicus, and one of ballast, behind the victim and their flotation chamber. A very small amount of buoyancy and ballast securely attached to the victim at these two points is sufficient to roll an individual over and put them on their back, thereby protecting their airway from submersion. Entry and adjustments are from below, from the side or if from the front then the front chamber must overlap and be maintained and secured in a central position. Only this combination of small buoyant chambers reliably creates safe positioning of the victim's neck and head. This face up righting moment is generated regardless of the angle of entry into the water or level of conscious participation. This strong righting moment also compensates for the ongoing effects of rotational forces such as waves that at a certain point will overcome the lateral stabilization provided by the rear perimeter chamber.

Ideally the rear chamber is constructed to cradle the head and neck preventing it from drooping over backwards or sideways and becoming submerged. The chamber can be extended along the sides where they act much as outriggers, stabilizing the body from being rolled over because of wave action. The perimeter rear buoyant chamber defines a space, and actually forms a containment means for stowing a separating flotation chamber, such as a multi-function rescue safety product. It also is the ideal site of expansion that occurs when an inflatable life vest is actually inflated. All inflatable buoyant chambers upon inflation convert from a two dimensional product to a space occupying three dimensional object. This creates a shortening that results in constriction. Power inflated vests generally have an over pressure valve to protect against rupture but before this is actuated an unacceptable amount of pressure is applied to the thorax of the wearer. To compensate for this either the

EXHIBIT 9
Page 78 of 11 pages

US 6,530,725 B1

7

garment is very loose so that when it is inflated the wearer can still breathe or the chamber slides along a retaining strap or belt shifting the position of the inflatable bladder and thereby shifting the righting moment. Current inflatable vests upon inflation slide to the rear as an accommodation to the front entry. This pulls the buoyant means towards the back and results in greater moments of stability in the side high position which submerges the airway. In the current embodiment if the vest is entered from the front its closure is fixed. The rear buoyant chamber upon inflation stretches away from the center of the back and out towards the sides strengthening the lateral stability of the vest and the forward central buoyant bubble remains aligned along the center.

There are several reasons that most life jackets are vest style; the historical basis of clothing design, the need to locate the required amount of lift required by the regulatory agencies and the degree of fit. The buoyancy generated by the life vest must be able to be secured reliably about the torso of the wearer. Entry into the water or rough surface action must not strip the life jacket from the victim, in this regard the secure closure, appropriate sizing and an elastic component combine to provide a reasonable attachment. The only way to be assured that the victim and their life jacket will not be separated is by the inclusion of a crotch strap. Once again compliance is a function of comfort. If the crotch strap is loosely attached prior to entry into the water then easily adjustable while in the water, it might be used. A wet, limp, unconscious victim being tossed about by waves will require a retaining strap between the legs to optimize the survival value of any buoyant product attached to the victim. Its inclusion in a life saving system is necessary, the option of its timely use is a function of comfort and cosmetics. Another reason for the current vest design of water safety products is that the Coast Guard use to require certain amounts of buoyant lift for varying classes. Commercial requirements exceed those for personal use, but all classes displace such a large volume of water that the buoyant means needs to be spread out over a large surface area such as is provided by a vest style life jacket configuration, despite its serious drawbacks.

Some vest style life jackets have four righting moments; face up, back up, left side up and right side up. The current invention creates a broad base triangle. Central to this invention's uniqueness is a small buoyant bubble that is centrally located in front of the wearer, and a small amount of ballast posterior. The front chamber is responsible for initiating the righting moment and the counterweight eliminates the side position, and supplies the rotational energy needed to roll the victim over onto their back thereby assuring that the victim's face will be out of the water regardless of the angle of entry. Once the forward chamber has reached the surface, it in conjunction with the dynamics of a limp unconscious body, will oppose any tendency for the waves to roll the victim over into a face down position that would compromise the airway. If the front chamber is too wide, it can combine with the rear buoyant bladder and create a second, life threatening righting moment in which either side could be held at the surface and concomitantly the airway submerged. In summary, the rear buoyant chamber provides a base of support for the head and neck, supporting the airway and providing lateral stabilization, opposing rotational motion of the waves from over turning the victim into a face down position, but in the event that occurs, the forward buoyant bubble that is located at the umbilicus will automatically flip the victim back over onto their back, reestablishing the heads up orientation.

While the forward and rear buoyant chambers could be constructed form a single chamber, ideally two or more

8

chambers confer several advantages. In this design one of the chambers is retained by a releasible system. This feature allows the wearer the option of being able to remove a chamber and use it as a distress marker, thus the preferred embodiment is to construct the forward chamber from a highly visible and radar reflective material. Separation also allows the chamber to be used as a rescue device. It can function as a rescue board to approach a swimmer in distress or used as a buoyant assist beneath the arms of the rescuer to provide lift in the event the rescuer is attempting to perform artificial respiration while in the water.

In adapting the product for the scuba diver, the separating chamber can be used under water by the advanced diver to mark a dive site such as in search and rescue attempts. The separating bladder can also be used as an underwater lift or salvage device rather than the common but unsafe practice of using the divers high lift buoyancy compensator as a salvage device. In the event that the object being salvaged slips from the divers grasp, the diver suddenly becomes markedly buoyant and is thrown into an uncontrolled ascent. In the event of a sudden increase in boat activity the diver could leave the separating chamber at the surface marking the dive site, so that boaters will avoid driving over the partially submerged diver. The universal retaining strap of the releasible chamber ideally has an elastic component to allow for distention of the bladder when it is inflated. The separating chamber when modified for use underwater in a buoyancy compensator must be reliably regulated. Safe and secure containment of the bladder underwater is critical. As helpful as additional buoyancy is at the surface, that same buoyancy underwater represents serious exposure to rapid ascent with its numerous serious problems. On the other hand the surface flotation chamber must also be simply and quickly deployed to be of assistance of an emergency at the surface.

Because the volume of the buoyancy compensator has been reduced to mitigate the chances of rapid ascent, it is foreseeable that the forward surface flotation chamber may not be deployed in an acute emergency underwater so the rear chamber and the disclosed keel weight have to be sufficient to protect the airway by establishing a heads up orientation with or without the deployment of the forward chamber.

When an air cylinder is attached to the heads up life vest, the life vests counterweight must increase in size to offset any additional outrigger effect. It is called a keel, because when the diver is lying face down at the surface and goes limp, the tank compensating keel weight, like the keel of the sail boat will roll the diver over onto their back, stabilizing the airway out of the water. The compensating portion of the name is because the size of the weight is in proportion to the type and size of the vest, cylinder and whether the water is fresh or salt. If the cylinder when empty is neutral to slightly negative it will sink allowing the diver to roll over onto their back. The keel weight in other words compensates for the buoyancy shifts of the diver's jacket and air cylinder. If the cylinder remains negative when empty then the keel weight can be smaller but still must generate sufficient angular momentum to offset the secondary righting moments generated by an imbalanced weight belt and attached gear or bladders. If the keel weight is used as an adaption to existing vest style buoyancy compensator, then it has to be strong enough to overcome the side righting movements generated by the common practice of using buoyancy under the arms.

Central to the tank compensating keel weight's design is that it be made of a very dense material such as lead, and be located exactly opposite the diver on the back side of the

EXHIBIT
b
Page 26 of 41 pages

tank. Traditionally the buckle that generates pressure on the belt that attaches the buoyancy compensator to the tank is located in the center at the back of the tank. Because the posterior central position is so critical for the performance of the keel, the buckle has to be moved off center. This shift in the cam buckles location results in a slight inconvenience in terms of reduced access but is necessary to preserve the critical location and therefore the righting moment of the compensating keel weight.

Ninety (90%) percent of drowned divers are often found with their weight belts still on and fifty (50%) percent of such are at the surface. Usually the weights are located along the waist and the amount runs from a couple of pounds to more than forty pounds. As the amount of weight increases, the keel weight needs to be located higher up the air cylinder to offset the placement of the weight belt. The dual tank band allows for a wide variation of weight placement. Obviously, the keel weight could be incorporated into the metal of the cylinder, adhered to the cylinder, enclosed in a covering of any sort, or even attached with magnetism. A pouch or cylinder could be used to contain lead shot or beach sand as long as it is located along the longitudinal axis of the cylinder and thereby serves to generate the heads up righting moment.

Additionally the concept of critical ballast is such that a certain amount of ballast is absolutely required in order for the diver to stay underwater. To facilitate the concept of safe diver weighting the tank compensating keel weight is also used to offset the inherent buoyant material from which the buoyancy compensator itself is constructed. Thus, because of the tank compensating keel weight, the buoyancy compensator, the tank, and regulator combination is neutral and as such does not contribute to the consolidation of additional ballast on the weight belt. If the quick release buckle of a consolidated weight belt should snag on a plant or slip out of hand during adjustment at depth the dangers of an uncontrolled buoyant ascent are somewhat mitigated because the shift in buoyancy is reduced by the amount of ballast used as a tank compensating keel weight.

While the forward chamber is not critical for protecting the airway of the scuba diver because of the effectiveness of the tank compensating keel weight, the forward chamber's ability to provide additional high lift surface flotation fulfills an expectation in the sport. The key to the addition of high lift surface flotation to the diver underwater is its safe regulation. The operation of the forward chamber requires diametric opposed properties of the valve chosen to regulate the chamber. One embodiment employs the use of a variable fabric valve fabricated from a self releasible hook and loop fastener such as VELCRO® that can operate in three different modes, as a manual on/off valve, semi-automatic valve or a fully automatic valve. In addition, as the fabric valve ages its strength can be renewed by further increasing the interactive surface area.

The value of including a variable valve in line between the rear chamber and the forward chamber is that the diver can become more responsible with experience and training for the total amount of lift available to the diver underwater as well as at the surface and thus more responsible for uncontrolled ascent rates and consequently the risk of pulmonary barotrauma, arterial gas embolism and its frequent outcome cerebral infarction as well as the risks of decompression sickness.

Some dive instructors fear that the beginning student will not be able to perform an additional task in an emergency and therefore prefer that the entire buoyancy system auto-

matically inflate choosing simplicity of operation at the expense of exposing the beginning diver to the consequences of a more rapid uncontrolled ascent, despite the fact that deaths have occurred during buoyant ascents while training in a swimming pool. In particular, since the student will be involved in a lot of surface drills and exercises, such as determining how much weight they require in order to be able to submerge, clearing their masks and snorkels, and since the first dives will be shallow, the consequences of rapid ascent are severe. As their experience grows and their comfort in the water with their gear and the concepts of correct weighting develop, they will be making deeper dives where the consequences of sudden ascent continue to mount and become progressively more severe. As the student begins to submerge and the lungs become more pressurized the manual operation mode of the valve is necessary for the diver to safely regulate the total amount of lift attached to their body underwater and thereby mitigate one of the major risks of diving.

As the buoyancy compensator is reduced to a device dedicated to contain the small amounts of lift actually required while underwater, some instructors are concerned that the diver will not be able to rely on the buoyancy compensator for a buoyant ascent. The problem with buoyant ascents is that they are very difficult to control when all the divers' faculties are intact. In an emergency the ability to regulate a high lift buoyancy compensator at depth is very unlikely. Optionally, one of the forward chambers can be a low volume chamber designed for emergency ascent which has incorporated a rupture plug, disc or weld so that if the product is deployed unintentionally by use of a CO2 cylinder or the divers air cylinder, or accidentally, it will self destruct at a preset pressure differential, limiting its buoyant assist to the first leg of an emergency ascent allowing the diver a second chance to regain control and reduce their velocity to a safe rate. Some of the larger high lift surface flotation chambers may never fill to rupture so its containment system that regulates its inflation must be very secure to be assured that it will only be deployed intentionally, otherwise the diver would be in the same high lift rapid ascent predicament that they currently find themselves in with today's product.

Incorporated within the multi-chambered heads up safety vest is a multi-function rescue safety product which can culminate into a raft for removal of the victim from the water and thereby confer protection from hypothermia. The needs and use of this rescue safety product determines its requirements for durability which in turn determines the type of fabric, its storable volume and therefore the location of the rescue product within the safety vest. The primary flotation device or life vest stays secured to the individual to assist them during their entry, and support them while they are deploying the rescue product. Once inflated if the product is not needed for rescue or signaling, the rescue product evolves into a raft that the individual can crawl into. The life vest remains on the victim protecting the individual should they be washed overboard as well as insulating the trunk, further helping to maintain core temperature.

The need and uses of a rescue device varies with the application. For the civilian airline passenger suddenly thrust into a survival situation, they are provided with a floating cushion or a lightweight inflatable life vest. In this situation a single use, ultra lightweight product is ideal. Such a rescue product might be constructed from an all welded mylar film. A multiplicity of layers would confer separate air chambers within the product providing for insulation, conferring a puncture protection while remaining small enough

EXHIBIT D
Page 21 of 31 pages

US 6,530,725 B1

11

to fit inside a seat cushion or within a pocket of a purely inflatable life vest. To facilitate the single use products operation the oral inflator would lead to a manifold which could be constructed of differing diameters and/or which would pass through separate one way check valves of differing relief pressures. The diameter and/or pressure relief valves would direct the flow of air such that the chambers could be inflated sequentially. As pressure in the system builds up after inflating the first air chamber the second begins to inflate. The arrangement would allow for the inflation of a life ring first, followed by the rescue float, then if necessary a large outer tube would convert the rescue product into a raft with a canopy arch. The mylar, in addition to reflecting the radiant energy back towards the victim, is mirrored so that it is highly visible and radar reflective both of which would facilitate search and rescue. It structurally would resemble a single use raincoat. With the advantages conferred by this invention the victim could be of assistance to themselves and to others. Survival would be increased from minutes to days, dehydration would become the next serious threat to the survivor. An off the shelf plastic solar still could be easily included for trans-oceanic passages.

The water enthusiast on the other hand may find themselves in the water more often than the civilian airline passenger and their needs may tolerate slightly more bulk from the stored rescue product in exchange for reusability. The bulk increases because of the demands of a more durable and reusable product requires a more substantial choice of fabric. As the bulk increases, the location for stowing the rescue product becomes more critical. The ideal location is built into the back of the life vest where it is out of the way but securely and accessibly stowed until needed. In this posterior and inferior position the actions of the new and improved life vest are retained, that is the perimeter of the torso is supported by the rear inflation chamber of the life vest, stabilizing the victim against inadvertent rotation to a face down position. The location of the raft, is ideally within the walls of the life vest, protecting the raft from the shearing forces of entry, freeing the hands to assist entry and recovery once in the water. An envelope for containing the rescue product could be provided so that it could be attached to the inside or outside of any current life vest and thereby confer the protective advantages to all owners of a life vest without having to incur the cost of buying a new life vest. This would allow all current owners of a safety vest to upgrade to a dual chambered separating water survival system. This attachment system employs a hook and loop fastener looped through the arm holes and is universally adaptable to all life vests, of all sizes. Any releasable fastener such as buttons, zippers, snaps, hook and loop, etc. would allow for the rescue product and its stowage and release system to be located comfortably centered both up and down as well as side to side. While it could be positioned outside the life vest, its inclusion within the life vest will ensure its secure attachment. The inflation of the rescue product is determined by its use, cost, and available stowage space but since oral inflation is not restricted by shelf life, it is always present and most affordable. Inflation via a manifold will allow the rescuer to provide a rapidly inflated life ring to help stabilize the victim through the initial insult and then provide a float while the remainder of the chambers are inflated. In the current embodiment the rescue product is built into the safety vest or floating cushion, if anyone in the water intentionally or accidentally and is sequentially inflated through a series of rescue products that culminates in a raft for removal of the individual from the hypothermic effect of the water.

12

An additional advantage of the disclosed invention is directed to the adaption necessary when the safety vest is used underwater by the scuba diver. In this application the heads up safety vest would be called a buoyancy compensator or BC. Because of the serious consequences of rapid ascent on pressurized lungs, in addition to the reliable regulation of the high lift surface flotation component of the buoyancy compensator, the primary buoyancy compensation bladder should be variable size. By design the buoyancy compensator is to be used underwater where it is vulnerable to inflation from entrapped pressurized air at two to three atmospheres, as well as subject to inflation from panicked misuse or mechanical failure of the power inflator, all causes leading to the same result, dangerously rapid ascent rates. The volume of the bladder should be tailored to the dive environment. The dedicated buoyancy compensator can be adjusted to the lowest volume needed to accomplish the goal of compensating for compression of thermal protective gear and the resultant loss of buoyancy. As the dive environment changes, so does the need for thermal protective gear. In tropical water minimal or no protective gear is worn and therefore the diver has nothing to compress and so experiences no loss of buoyancy at depth. For the diver in a bathing suit, the need for a power inflatable bladder underwater is limited to the shift in buoyancy that occurs in their air cylinders, and usually is well under 5 or 6 pounds of lift. This chamber is only needed to cover the initial overweighting needed to allow the diver to be neutral at the end of the dive in order to make a safety stop. This product should not be called a buoyancy compensator as a first step in reeducating the diving population about the dangers of power inflatables underwater.

In cold water, at 120 feet of depth, a 190 lb. diver in a ¼ inch neoprene wet suit experiences a loss of 9 lbs. of lift due to compression of the wet suit. Most sport divers are smaller and therefore are wearing less neoprene, dive in warmer waters and/or making shallower dives. There is no justification for subjecting a diver to unnecessary risks of rapid ascent. Due to the extreme danger of pulmonary rupture and secondary air embolism that results from a rapid uncontrolled ascent it is imperative that the buoyancy compensation chamber be restricted to the lowest volume absolutely necessary to accomplish its goal. Any lift over and above the minimum amount exposes the diver to unnecessary risk. The diver doing repetitive dives in one day is advised to do their deepest dive of the day first and will need a buoyancy compensation capacity commensurate with their thermal protective gear and dive plan. As the dives become shallower and consequently warmer as well, the volume of an adjustable buoyancy compensator can be reduced, and consequently reduce the divers exposure to the risk of rapid ascent. Recommended ascent rates are dropping from 60 feet per minute to 20-30 feet per minute. The medical literature notes that a 30 lb. buoyancy compensator can produce average velocities in excess of 250 feet per minute from less than ten feet under the water. For several generations, divers dove without a buoyancy compensator so its use cannot be construed as critical. The advent of this convenience product has resulted in ballistic ascent rates because of the air entrapped inside the product which is pressurized at depth which then doubles and possibly quadruples upon ascent depending on the initial depth. An inexperienced diver in an "out-of-air" situation is prone to forget about the intellectual concept of arterial gas embolism in the hypoxic and hypercapnic driven race to the surface, only to die from an arterial gas embolism before ever getting a chance to drown. Drowning is a slow, reversible process that lends itself to

rescue for quite some time after the event, unlike arterial gas embolism. When using an adjustable dedicated buoyancy compensator the diver can very precisely control their exposure to the dangers of an emergency ascent through the water column and thereby significantly reduce the risks of rupturing a lung and suffering an arterial gas embolism to the brain or heart or similarly reduce the risks of suffering the bends because of missed decompression stops.

An alternate location for a separating forward surface flotation chamber is for its inclusion within the shoulder straps. The redundant personal flotation device is designed to be separated away from the remainder of the dive gear to provide complete duplication of personal flotation devices in the event of failure of the primary chamber. The chamber can also be used as a rescue, signaling, salvage product or snorkeling vest.

Appropriately sized releasable shoulder trim weights offset the operation of the buoyancy compensator underwater, improving swimming position, decreasing frontal area, producing less hydrodynamic resistance and consequently less diver fatigue. Once again, the shoulder trim weight results in a reduction of the consolidated weight belt with its inherent advantage of protecting the diver from accidental loss of all ballast at one time.

In summary, a multiple chambered life vest can be of a low volume, low lift, and low profile design as long as at least two points in need of buoyancy are covered, behind the neck and at the umbilicus and one point of ballast along the vertical posterior axis. Excessive buoyancy can be extremely detrimental either because the product is not actually worn because it is too bulky or because side righting moments have been created that jeopardize the airway. The separating chamber in the hands of a conscious, capable user can be removed providing a signaling device for facilitating search and rescue efforts or used as a rescue board minimizing the risk associated with attempting to rescue another victim who has become hypoxic. After the initial insult has been survived the user can deploy the incorporated inflatable rescue product that sequentially inflates into a life ring, then rescue board and distress marker and culminates in a raft to remove the victim from the water with its inevitable and often rapid hypothermia. The entire water safety survival system constructed for a single use application could easily fit within the air line seat cushion, dramatically improving survival statistics for accidents at sea.

The multi-chambered heads up safety vest as adapted for the scuba diver allows for reliable segregation of a variety of high lift surface flotation chambers while underwater. In addition a variable volume dedicated buoyancy compensator allows the diver to further reduce the amount of lift attached to the smallest amount necessary for a particular dive environment. The combination of these two improvements will markedly reduce the largest cause of pulmonary barotrauma, and secondary embolism, a major cause of injury and death in the field of diving.

The inclusion of a couple of pounds of weight integrated into the posterior axis of the victim's vest will allow the victim to overcome numerous minor righting moments that can place the airway of the exhausted or distressed victim under the water leading to drowning another major cause of death in the sport of diving. The benefits of the tank compensating keel weight are so dramatic that they can be included into a separate product that can retrofit existing buoyancy compensators, converting them into a heads up product. The inclusion of the multi-function rescue product within the walls of the buoyancy compensator confers on

that diver the ability to respond to a number of problems frequently encountered by the diver in rescue, marking and salvage.

Thus, a water safety and survival system that provides a multi-chambered personal flotation device that operates on minimal volume to create a single heads-up righting moment that reliably stabilizes an unconscious victim with his airway out of the water is disclosed in one embodiment. This is accomplished with a minimal amount of lift, less deflated bulk, improved cosmetic appeal, and reduced cost. These combined advances result in a safety vest conducive to actually being worn, a key feature for a safety vest. The system also provides for incorporation of a separating second inflatable life ring, rescue board, artificial respiration assist platform, and ultimately a raft for removal of the victim from the water to protect him from hypothermia. This sequentially inflated, multi-chambered, multi-faceted inflatable rescue product is incorporated within the body of the safety vest. The incorporation of a wide range of rescue products into the body of the person flotation device will reduce the incidence of that dual tragedy that occurs when the rescuer becomes the second victim. This water survival system, when adapted to the special needs of the scuba diver, requires the incorporation of a tank compensating counterweight to offset the deleterious effects of a buoyant empty tank whose buoyancy can force the diver's airway under the water. Further adaptation for use underwater also includes a system to adjust the volume of the primary buoyancy compensation chamber and variable valve for segregation and reliable regulation of one or more additional surface flotation chambers underwater. The design of the separating chambers coincides with responsibilities and goals of the diver. These and more modifications for the safe underwater use of the heads-up safety vest are critical in order to mitigate the risk of rapid ascent and its consequences, arterial gas embolism and decompression sickness.

In accordance with these and other objects which will become apparent hereinafter, the instant invention will now be described with particular reference to the accompanying drawings.

BRIEF DESCRIPTION OF THE DRAWINGS

FIG. 1 is a view of a personal flotation device shown incorporating the multi-function rescue product within the back wall of the vest.

FIG. 2 is a view of an existing buoyancy compensator with the multi-function rescue product attached.

FIG. 3 is a view of an airline life vest carrying a multi-function water rescue safety product.

FIG. 4 is a view of an airline seat cushion modified by the inclusion of an ultra lightweight disposable multi-function rescue safety product.

FIG. 5 is a view of an inflation manifold.

FIG. 6 is a top view of a multi-chambered rescue product.

FIG. 7 is a cross section view of the multi-function rescue product fully inflated.

FIG. 8 is a view of a face up personal flotation device modified for scuba diving.

FIG. 9 is a view of the scuba diver with an inflated separating horse collar, and self rupturing emergency ascent chamber.

FIG. 10 is a view of the inflatable cummerbund, with a releasable forward chamber, carrying an alternatively forward chamber in the form of a float.

FIG. 11 is a view of the pyramidal structure with central forward buoyant chamber and rear buoyant chamber.

EXHIBIT B
Page 28 of 111 pages

FIG. 12 is a combined view of the elements of the water safety and survival system as it is adapted to the scuba diver.

FIG. 13 is a front view of the adjustable buoyancy compensator.

FIG. 14 is a rear view of an alternate adjustable buoyancy compensator.

FIG. 15 is a front perspective view of a first counter weight member in accordance with the present invention.

FIG. 16 is a back perspective view of the counter weight member illustrated in FIG. 15.

FIG. 17 is a front elevational view of the counter weight member illustrated in FIG. 15.

FIG. 18 is a back elevational view of the counter weight member illustrated in FIG. 15.

FIG. 19 is a side elevational view of the counter weight member illustrated in FIG. 15.

FIG. 20 is a top plan view of the counter weight member illustrated in FIG. 15.

FIG. 21 is a front perspective view illustrating a first attachment embodiment for a first counterweight assembly in accordance with the present invention.

FIG. 22 is a front perspective view illustrating a second attachment embodiment for a first counterweight assembly in accordance with the present invention.

FIG. 23 is a back perspective view illustrating the second attachment embodiment for the first counterweight assembly.

FIG. 24 is a perspective view illustrating a connection portion of a coupling strap in accordance with the present invention.

FIG. 25 is a front perspective view illustrating a second attachment embodiment for a first counterweight assembly in accordance with the present invention.

FIG. 26 is a top plan view of the counter weight member illustrated in FIG. 15 having at least one suction cup.

FIG. 27 is a side elevational view of the counter weight member illustrated in FIG. 15 having a plurality of suction cups.

FIG. 28 is a front elevational view of a second embodiment counterweight assembly in accordance with the present invention in a flap open position.

FIG. 29 is a top elevational view of the second embodiment counterweight assembly with the flap removed.

FIG. 30 is a front elevational view of the second embodiment counterweight assembly in a flap closed position.

FIG. 31 is a side elevational view of the second embodiment counterweight assembly.

FIG. 32 is a front elevational view of a third embodiment counterweight assembly in accordance with the present invention.

FIG. 33 is a side elevational view of a weight member utilized with the third embodiment counterweight assembly.

FIG. 34 is a perspective view of a fourth embodiment counterweight assembly in accordance with the present invention.

FIG. 35 is a top plan view of the fourth embodiment counterweight assembly.

FIG. 36 is a perspective view of a fourth embodiment counterweight assembly in accordance with the present invention.

FIG. 37 is a perspective view of a fifth embodiment counterweight assembly in accordance with the present invention.

FIG. 38a is a front elevational view of the fifth embodiment counterweight assembly.

FIG. 38b is a front elevational view of a soft weight member in accordance with the present invention.

FIG. 38c is a front elevational view of a hard weight member in accordance with the present invention.

FIGS. 39a through 39e illustrate the various steps which are performed for removing a pouch member and associated weight member from a pocket member for the fifth embodiment counterweight assembly of FIG. 37.

FIG. 40 is a front perspective view illustrating a combination of counterweight assemblies in accordance with the present invention utilized together.

FIG. 41 is a back perspective view illustrating a combination of counterweight assemblies in accordance with the present invention utilized together.

FIG. 42 is a perspective view of a diver having his or her airway submerged.

FIG. 43 is a perspective view of a diver having his or her airway protected in accordance with the present invention.

FIG. 44 is a perspective view of a training device for determining proper size and location for the weight member in accordance with the counterweight assemblies of the present invention.

FIG. 45 is a perspective view of a quick disconnect member in accordance with the present invention.

FIG. 46 is an enlarged perspective view of a male portion of the quick disconnect member illustrated in FIG. 45.

FIG. 47 is a perspective view of a prior art quick disconnect member having its female portion in section.

FIG. 48 is a view of the personal flotation device shown in Figure and incorporating a counterweight member.

FIG. 49 is a view of the airline life vest shown in FIG. 3 and incorporating a counterweight member.

FIG. 50 is a view of the face up personal flotation device shown in FIG. 8 and incorporating a counterweight member.

FIG. 51 is a view of the scuba diver with the inflated separating horse collar shown in FIG. 9 and incorporating a counterweight member.

FIG. 52 is a view of the pyramidal structure with central forward buoyant chamber and rear buoyant chamber shown in FIG. 11 and incorporating a counterweight member.

DESCRIPTION OF THE PREFERRED EMBODIMENTS

FIG. 1 shows victim 201 wearing a vest 203 that can function separately as a snorkeling vest, personal flotation device for boating or alternately hooked up to the primary bladder of a buoyancy compensator through quick release means 91 and hose 70 that is attached within pocket 74. Vest 203 can also be inflated through oral inflation means 72. Additionally, vest 203 can be incorporated with a ballast means 100 (FIG. 48). A multi-function rescue product and raft 207 is stowed within the back pocket of the lift vest between the outer wall 208 and inner wall 209. A retrieval strap 211 opens the pouch formed by wall 208 and wall 209, and is wrapped around raft 207 allowing the user to remove rescue product and raft 207, comprised of an expansible material allowing inflation chamber portion 73 located along the perimeter of the back to roll forward upon inflation.

FIG. 2 shows a diver 202 adapting an existing vest style buoyancy compensator 204 to carry the rescue product 207 within a containment pouch 210, held in place by band 23 that is supported by arm holes 24. A retrieval strap 211 is

EXHIBIT
b
Page 83 of 167 pages

wrapped around rescue product 207 so that it can be removed from the containment pouch 210 without having to remove the vest 204. The scuba tank 102 is standard.

FIG. 3 shows a typical inflatable vest 205, as might be worn by an airline passenger 201, that is strapped to the victim by strap 214, in the event of a water landing. The typical vest 205 is modified by addition of a containment pocket 213 that stows a single use rescue product 207. Additionally, vest 205 can be modified by the addition of a counterweight 100 (FIG. 49).

FIG. 4 shows an airline cushion 206 containing rescue product 207. The victim puts their arms through straps 15 to secure the cushion 206 to the victim during water entry.

FIG. 5 shows a manifold device 17 that connects an oral inflator 16 through barbed fittings 18 to a series of one-way check valves that can also function as variable pressure relief valves 19, 29, 39, 39, and 59 that connect via tubing 20, 30, 40, 50, and 60 to a series of inflatable chambers as are demonstrated in the next drawing, FIG. 6.

FIG. 6 shows a multi-function rescue product and raft 207, comprised of life ring 21 which is inflated by tube 20 which because it has the largest, diameter tubing and because the pressure relief valve 19 has the lowest relief pressure setting, will inflate first. Inflation chamber 31 or the floor is the second to inflate. Chamber 41 is a second chamber in the floor and because of the setting of the pressure relief valve and/or the diameter of tube 40 would be the third chamber to fill. The first three chambers; the life ring 21, and the floor chambers 31 and 41 form a rescue board or distress marker. The next chamber is a wall tube 51 and that can be inflated while resting on combined chambers 21, 31, and 41. The final chamber 61 forms an arch, supporting a protective canopy. In its last configuration, the multi-function rescue product 207 can be inflated to a raft constructed from radar, solar, and infrared reflective material.

FIG. 7 shows construction of rescue product 207 in cross section, highlighting the various chambers and their sequence in inflation, life ring 21 first, portion of floor 31, remainder of floor 41 second, high volume tube wall 51 third, arch canopy tube 60 last. Ideally, the floor is doubled or tripled to provide thermal insulation from the water and puncture resistance.

FIG. 8 scuba diver 202 is shown wearing a heads up, multi-chambered, dedicated, rear mounted, adjustable buoyancy compensator having an inflatable chamber 85 connected with hose 83 through quick release coupling 91, and through one-way pressure release valve 82 to a releasable inflatable shoulder harness 80 that is stowed in a folded configuration. In FIG. 9, the shoulder harness 80 is inflated. In FIG. 8, an alternate or concurrent surface flotation bladder having an inflatable chamber 90 can be connected to buoyancy compensation chamber 85 by tube 93, which is regulated by one-way check valve 92, and can be separated from the diver for rescue, salvage or marking activities by quick release coupling 91. In FIG. 8, it is noted that the life vest comprised of inflatable chambers 85 and 90 is snug but releasably attached to diver 202 by a crotch strap 94. The diver 202 in FIG. 8 is holding an air hose 191 which couples to the male quick release coupling 192 on the power inflator 87, or can be used to inflate rescue product 207 of FIG. 2 or can be used as a high pressure air source for the rapid inflation of chamber 90 when it is being used in a rescue attempt. Additionally, a counterweight 100 can be provided (FIG. 50).

FIG. 9 shows an adjustable buoyancy compensation chamber 85 reduced in volume by rolling up the side

chamber as shown at 130. An automatic rupturing emergency ascent chamber 180 is inflated from buoyancy compensation chamber 85 through quick release coupler 91, or by a separate compressed gas cylinder such as a CO2 cylinder 215. Standardized retaining strap 110 as found on all the interchangeable forward bladders. Strap 110 keeps bladder 180 from separating from diver 202 until the quick release buckle 103 is opened. Retaining band 104 is expandable allowing for the forward chamber to expand away from the diver upon inflation. In an uncontrolled ascent the diver is unlikely to operate the venting mechanism 183 in which case a rupture plug 182, can be provided, which crosses a weld line 181 weakening it so that as the chamber 180 pressurizes upon ascent, it will rupture out at the weakened point, thereby reducing total lift attached to diver 202 and helping to control the ascent velocity. In FIG. 10 diver 202 demonstrates two of a wide variety of different releasable forward chambers indicated generally as inflatable means 90 stored in the waist band in FIG. 8. Additionally, a counterweight 100 can be provided (FIG. 51).

FIG. 10 shows the diver 202 whose waist band 95 is retaining releasable separating forward chamber 97 which is a redundant horse collar life vest and rescue product. Expandable element 104 stretches upon inflation of the forward chamber 97. In an emergency the horse collar vest 97 can be released from the divers buoyancy compensator by quick release buckle 103. The same quick release buckle is used for releasing the shoulder strap as is standard in the art, and familiar to divers. After releasing the forward vest 97 from the waist, the diver then disconnects the horse collar life vest 97 from its source of power inflation the buoyancy compensator 85, by using the quick release coupling 91. Once the forward chamber has been separated from the rear chamber 85 and diver 202, it can be employed as a rescue board, tied off as a bottom marker, left at the surface to warn boat traffic, or held aloft as a high visibility distress marker. In FIG. 10, the diver 202 is carrying a rescue board, distress marker, surf mat as an alternate separating forward surface flotation chamber indicated as 96. Chamber 96 can be retained by guides 110 on strap 104 of the divers waist band. In FIG. 10, chamber 96 is shown with oral inflation means 98 and quick release coupling means 192 which couples to quick release coupling 91 thereby connected to the rear buoyancy compensator 85, or to the air hose from the air cylinder for more rapid inflation. Retaining flap 106 serves to store the releasable forward chamber 97 or 96. Pouch 160 is sealed by flap 161 and is used to contain a small amount of lead shot to offset the buoyancy of the materials used to construct the forward chamber as well as its containment system. On the upper shoulder straps of the diver 202 in FIG. 10, D-ring 172 is attached to hook and loop covering flat 173 that is attached to underlying fabric walls 175 to create a quick release pocket for a lead shot filled pouch 174.

FIG. 11 demonstrate the pyramidal structure of the multiple chambered heads up life vest. The vest is comprised of a rear U-shaped buoyant chamber 121 and the forward centrally located buoyant chamber 120. The triangle 123, formed by chamber 120 and 121 has a single righting moment, face up. The victim 201, and his airway 124 are maintained out of the water whether or not the victim is conscious. A counterweight 100 can also be provided with the life vest (FIG. 52).

FIG. 12 shows a composite of the water safety and survival elements disclosed herein. In FIG. 12 the diver 202 is unconscious but his airway 124 is held out of the water. A generic centrally located inflated chamber 105 is retained by expansible strap 104 and could be released by quick

EXHIBIT D
Page 30 of 44 pages

US 6,530,725 B1

19

release buckle 103 if the diver was alert and it was needed for rescue or for use as a distress marker for search and rescue activities. Waist band 95 is secured in place by buckle 178 which is mounted on a Velcro® base 179 that allows the waist buckle to be adjusted along the length of the left side of the waist band 177 to accommodate the variation in waist size that occurs as different types of thermal protective gear are worn. The buckle 178 is off to the side so that the generic forward flotation chamber 105 retains its critical central location. The forward chamber retaining flat 106 is attached by hook flap 108 to the loop material that covers the entire length of the waist band indicated as strap 95. This allows the forward chamber 105 to be quickly but securely adjusted to its central position. Operation of forward chamber 105 is regulated by the variable fabric valve 171 built into the retaining flap 106. The hook and loop components 171 of flap 106 can be varied by the inclusion of a reducer strip of hook 107. The size of the reducer strip 107 determines whether the flap 106 will open quickly under pressurized inflation from the rear chamber 85, open slowly or not at all. If the entire reducer strip 107 is removed the hook and loop means 171 are of sufficient strength to lock off the forward chamber. An over pressure valve 111 is located on the opposite side of the chamber 85 so that the diver can vary the position of the power inflator from the rear to the front by interchanging the power inflator 87 and over pressure relief valve 111. Rescue product 207 is contained in a pocket built into the rear wall of the buoyancy compensator 85 and is accessible by strap 211. Rescue product 207 is attached to the diver by a releasable lanyard 212. The tank compensating keel weight 100 is permanently attached to the tank retaining strap 109. Ideally, the tank compensating keel weight 100 is of a hydrodynamic conformation, made from a dense substance such as lead, coated in a soft film such as plastic so it will facilitate keel weight 100 being securely clamped in place by cam buckle 101. The soft coating will also avoid damaging the protective coating of the tank 102. The tank compensating keel weight 100 may be replaced by a standard lead weight so that the diver traveling abroad will not have to transport a lead weight. A diver in tropical waters may only require 5 pounds to descend while use of a dry suit in cold water can require 40 lbs. or more to be able to submerge, the greater the weight of keel weight 100, the stronger the face up righting moment it will generate. As the weight belt is increased because of the use of buoyant thermal protection, it is critical the keel weight 100 be increased. Regardless of the size of the keel weight 100 it is critical that it be located exactly opposite the diver and thus its position must be adjustable so that as the diver changes between diving cylinders of different diameters, keel weight 100 can be easily adjusted, by a non-user, to maintain its critical position. Ideally strap 109 is marked with a scale 176 to guide the diver in selecting the correct placement of keel weight 100 on cylinders of different diameters. If the keel weight 100 is slightly off center, it could summate with an imbalanced weight belt and stabilize the diver in side up position which will allow the airway 124 to submerge. Because the position of the keel weight 100 cannot be compromised, the cam buckle 101 is moved to a less accessible position on the side. A waist buckle 178 is attached to a hook fastener base 179 that allows it to be positioned anywhere along the left side of loop fastener covered waist band 177.

FIG. 13 discloses one of many designs for the construction of an adjustable buoyancy compensator 85. The portion of the buoyancy chamber that is held inaccessible to inflation is indicated as a rolled up portion of the buoyancy

20

compensation chamber 130. The loop portion of a hook and loop fastener forms the inside back of the buoyancy compensator and is indicated as 131. Loop 131 serves to attach the side chamber 136 by hook strips 132 to the body of the buoyancy compensator 85. Flap 138 is formed from the forward facing loop strip 137 and the rear facing hook strip 132. As the volume of the buoyancy chamber is reduced by rolling up the side chambers, the hook strip 132 adheres to the loop strip 137 to form and secure the roll 130. Clip 196 secures the rolled up grommets to prevent the chamber from unrolling under pressure from the air in the buoyancy compensator 85. The portion of the buoyancy compensator behind the neck is indicated as 134. In the current drawings the side chambers 136 are reduced in an infinitely variable fashion and an indicator 133 informs the diver of the remaining amount of lift provided by the buoyancy compensator 85. The indicator 133 allows the diver to quickly return to preestablished buoyancy compensator lift volumes as indicated for a particular set of dive gear. Quick release shoulder strap buckles 135 rely on quick release buckle 103 and are common in prior art. The lower shoulder straps 195 rely on nylon webbing loop 194 to establish structural integrity and internal hook fastener for positioning webbing loop 194 on the loop fastener covered nylon webbing waist band 95 and 177.

FIG. 14 depicts another retaining system for reducing the volume of adjustable buoyancy compensator 85. Double sided hook strip 151 and double sided loop strap 150 are used to lock off the reduced portion of the buoyancy compensator chamber 85. Double sided hook flap 152 attaches the rolled up chamber securely to the loop covered body of the buoyancy compensator 85. The reducible portion of the buoyancy compensator chamber is indicated as 136. The portion of the buoyancy compensator 85 that supports the neck and head is indicated as 134. The keel weight 100 is threaded on tank band 109, that is secured to the air cylinder by cam buckle 101. The hook flat 161 seals off the lead shot filled pouch 160 used to neutralize the inherent buoyancy of the buoyancy compensator.

OPERATION OF THE INVENTION

In FIG. 1, the water enthusiast is shown wearing a traditionally designed vest 203 which could be used in any recreational water sport. The vest 203 contains a multi-function rescue product and raft 207 within its rear pocket. If the ocean kayaker should become separated from his kayak at sea the victim 201 could pull on lanyard 211 and remove the rescue product and begin inflating it. A releasable attachment cord 212 will keep the rescue product from blowing or washing away. Because the vest 203 includes quick release coupler 91, the vest can also eventually be used as a forward chamber with the appropriate dedicated buoyancy compensator if the user becomes certified in diving.

FIG. 2 shows that the diver 202 wearing a current vest style buoyancy compensator 204 can adapt the rescue product 207 contained in pocket 210 to be carried between the diver and the tank by use of a strap 23 which passes through the arm holes of the buoyancy compensator. Access and use of the rescue product 207 is the same as described in FIG. 6 below.

FIG. 3 shows the victim 201 of a common carrier accident wearing a traditionally designed inflatable vest 205, modified with pocket 213 which contains a single use multifunction rescue product and raft 207 constructed from a mylar film and vacuum packed much as a single use raincoat. After

21

surviving the initial entry the product is inflated and used as a life ring, then rescue board or distress marker, and finally inflated to a raft if necessary to remove the victim from the hypothermic effects of the water.

FIG. 4 shows the airline or ferry safety seat cushion 206 containing the multi-function rescue product and raft 207. The victim's arms are placed through straps 15. The cushion 206 provides minimal safety in the water. The incorporated rescue product 207 would confer dramatic improvements in survival at sea.

Referring to FIG. 5, as the user exhales through oral inflator 16, the air passes into manifold 17 that connects multiple chambers to the oral inflator 16. The air is directed to the appropriate chamber according to the diameter of the tubing indicated as 20, 30, 40, 50, and 60. The one way check valves 19, 29, 39, 49, and 59 create structural integrity for each of the chambers down stream. If a puncture should occur only that chamber will lose pressure. If the oral inflator fails, the manifold 17 at its barbed connectors 18 can be disconnected from connector tubes 22 allowing separate inflation through each check valve. The simplicity of a single oral inflator will help the victim focus on a single task. Obviously, separate oral inflators could be used and the significance of which oral inflator is to be inflated first could be printed on the raft in multiple languages.

FIG. 6 is a top view of the multi-function rescue product and raft 207, fully inflated. The life ring 21 because of its small diameter is inflated first and quickly because of its low volume. This life ring could be used by the individual or extended to a family member. The floor chamber 31 and 41 would be inflated next also because they are low volume. Once inflated the first three chambers forms a float that gives the victim a sense of accomplishment. Inflated chambers 21, 31, and 41 create a four foot rescue board for approaching a flailing, distressed victim. The float can also be held aloft as a high visibility distress marker signaling other victims or search and rescue efforts. The inflated floor also gives a platform for the victim to rest on. If necessary the victim can rest on the first three chambers as they begin inflating the high volume side wall tubes 51. Once inside the raft the infrared reflective mylar would help to offset further loss of body temperature. Finally, the canopy arch 61 is inflated and the victim creates an enclosed space that is highly visible to the naked eye as well as radar. The multiplicity of chambers confers protection from puncture.

FIG. 7 is a view of the inflated raft 207 in cross section. The sequence of inflation, 21, 31, 41, 51, then 61 shows how the life ring would convert to a rescue float and ultimately to a raft.

FIG. 8 shows the scuba diver 202 holding a pressure hose 191 with its common female quick release coupler 91 disconnected from the male quick release coupler 192 of the power inflator 87. The common female coupler 91 can be attached to any of the other incorporated chambers such as the horse collar vest which is deflated and stored in the shoulder straps indicated at 80, or any of a multiplicity of deflated chambers that can be interchangeably stored in waist band as indicated at 90 or in the pocket. The high pressure hose 191 is employed to effect a more rapid inflation in an emergency. For routine operation of the chambers stored in the waist band or shoulder straps, they are in fluid communication with the buoyancy compensator chamber 85 through quick release couplers 91 and check valves 92. The crotch strap 94 is the only way the user can be assured that he will not be separated from his inflatable rescue product in heavy surf. With the auxiliary chambers

22

deflated and stored, the diver has a sleek profile with reduced hydrodynamic drag while swimming under water. Most importantly with the high lift surface flotation chamber stored it will not contribute its buoyancy to the total lift available to the diver under water.

FIG. 9 shows a diver 202 with a redundant separating shoulder mounted horse collar 80 inflated. The diver also is demonstrating the self rupturing emergency ascent chamber 180 inflated at the diver's waist. It is to be noted that the dedicated adjustable buoyancy compensator 85 has been reduced by rolling up the lower portion of the chamber as indicated at 130. If this reduced chamber was providing insufficient lift at a depth and the diver chose to attempt an emergency buoyant ascent the forward chamber 180 at the waist could be released. If the diver was out of air, the air pressure in the rear chamber would spill forward causing chamber 180 to inflate. Alternatively, chamber 180 can be inflated from its own compressed cylinder 215 when chamber 180 is disconnected at quick release coupling 91 or if air cylinder 102 and buoyancy compensator 85 are both empty. If the emergency ascent was uncontrolled, and the diver forgot to deflate chamber 180, it would self destruct at rupture plug 182, releasing its entrapped air, that had become pressurized because of the ascent. At that point the ascent rate would slow allowing the diver to regain control, further slowing his ascent rate to within the recommended rate of 20 to 30 feet per minute, rather than the ascent rates of 200 to 300 feet per minute, generated during an emergency buoyant ascent. If the diver should snag a fish hook in their primary chamber 85, then the horse collar vest stored in the shoulder straps would provide a redundant personal safety vest. In the event that the diver needed to ditch the dive gear, the power inflated forward horse collar safety vest can be quickly disconnected by quick release coupling 91. Alternatively, the horse collar can be separated and extended to the diver's buddy who has suffered a failure of his single chambered buoyancy compensator. If the diver was snorkeling the horse collar safety vest could be disconnected and inflated via oral inflator 84 and used independently from the remainder of the heads up safety vest.

FIG. 10 shows a diver 202 with a flap 106 which was used to enclose the flotation chamber 97 now shown in the open position. In front of flap 106 is the separating horse collar forward surface flotation chamber 97, inflated at the diver's waist. The forward chamber is retained by elastic webbing 104 that allows the chamber to expand away from the diver rather than constrict the diver's abdomen and therefore breathing. Quick release buckle 104 allows the diver to separate the forward bladder which can then be disconnected via quick release coupler 91. Once the flotation chamber 97 is free it can be used as a rescue float for approaching a hypoxic diver, held aloft as a distress marker, left floating at the surface to warn boat traffic of diver activity, used underwater as a bottom marker in search and rescue activities, or used as a small salvage device. For rapid emergency inflation the product can be stored in a pocket and connected to the air hose. Chamber 97 as it is currently shown is retained by strap 104 providing the central point of buoyancy that contributes to the heads up surface position. Though not required, the diver can be provided with quick release shoulder trim weights 174, retained by hook and loop fastener 173 and 175. The diver by pulling on D-ring 172 peels open the pocket and lead shot filled container 174 can fall away from the diver. The trim weights are exactly opposite the site of underwater buoyancy contained in the buoyancy compensator and helps the diver achieve an ideal balanced underwater and surface position. The diver 202 is

EXHIBIT B
Page 22 of 111 pages

also shown carrying an alternate forward or flotation chamber 96 which can be substituted for chamber 97 and secured to the diver by elastic retaining strap 104 which passes through strap eyelets 110 mounted on the edges of bladder 96. This larger float has all the same functions of the horse collar forward chamber 97 with the addition that it can be used as a transport raft for a disabled diver or act as a surf mat at the end of the dive for swimming back to shore.

FIG. 12 illustrates a composite of several of the disclosed inventions. The multi-chambered heads up safety vest modified for use by the scuba diver by inclusion of tank bands 109 which attach the tank 102 to a fully inflated adjustable buoyancy compensator 85. The tank bands 109 are longer than those currently located on buoyancy compensators in the marketplace. The extra length in tank band 109 is needed to allow the diver to thread on the tank compensating keel weight 100. The keel weight 100 can be located on the top, bottom, or on both tank bands 109 as needed. A diver in a bathing suit needs to locate the keel weight on the lower band. A diver wearing a buoyant thermal protective suit requiring a weight belt can shift the keel weight to the top tank band 109 to establish the ideal surface position. Cam buckle 101 is located off the side of the tank 102 so that the back side of the tank is available for placement of the keel weight 100. Over pressure relief valve 111 is located opposite the buoyancy compensator power inflator 87 allowing the two to be interchanged. The beginner is accustomed to the power inflator 87 coming over the shoulder but when located in this position power inflator 87 floats free and is often hard to locate underwater. When the power inflator 87 is mounted on the front of the buoyancy compensator chamber 85 it hangs straight down between the diver and the tank and is easily located when needed. The multifunction rescue product and raft 207 is located between the diver 202 and the tank 102. Lanyard 211 wraps around rescue product 207 allowing the diver to remove the rescue product 207 for use without having to remove any other dive gear. A generic forward chamber 105 is inflated and retained by elastic strap 104. The flap 106 includes a variable fabric valve comprised of hook and loop fasteners 171 that variably regulates the use of the forward chamber 105. Reducer hooks strip 107 decreases the amount of interactive surface in the fabric valve allowing the diver 202 to vary the operation of the fabric valve from automatic to semi-automatic, to manual. With the reducer strip in place the air pressure from the rear chamber is capable of forcing open the valve deploying the forward chamber without the diver needing to do anything. In the semi-automatic mode, the diver 202 partially removes the reducer strip 107, now the fabric valve 171 will swell because of the mounting air pressure, after a period of time flap 106 will eventually open. As the diver becomes more skilled and capable of operating the fabric valve 171 in flap 106 in the manual mode, he will totally remove the reducer strip 107. With no reducer strip 107 in place the strength of the fabric valve 171 exceeds the 2.5 psi over pressure relief valve 111 on the rear chamber or the small bore over pressure relief valve built into the oral inflator 193. On a rapid ascent from significant depths, pressure will build up at such a fast rate that the small bore oral inflator over pressure relief valve 193 cannot keep up and the forward chamber will rupture, protecting the diver from any further acceleration and will contribute to the diver's deceleration by removing the buoyancy contributed by the forward chamber. With no reducer strip 107 in place the high lift surface flotation device is safely locked away while the diver is underwater, reducing the amount of lift attached to the diver's body that entraps air or could be inflated by panic or

mechanical failure of the power inflator 87. Waist band buckle 178 is attached to hook and loop base 179 that allows the diver to quickly and reliably shift the position of the waist band buckle 178 to adapt the product to different divers or the same diver with different thermal protective gear.

FIG. 13 illustrates one way that an adjustable buoyancy compensator 85 can be assembled from the front. The body of the buoyancy compensator 85 is covered with loop fastener 131. The inside edge of the side chamber forms a flap 138 which has loop fastener 137 on the front side and hook fastener 132 on the back side. As the chamber is rolled up the hook and loop adhere along the inside edge and clip 196 locks the outer edge from unwinding under pressure from the air contained in the buoyancy compensator. The adjustable buoyancy compensator 85 gives the diver the ability to further reduce the amount of lift attached to his body to the absolute minimum needed for each dive profile and dive environment. Reducing unnecessary risk of rapid ascent, embolism and the bends.

FIG. 14 shows an alternate way to reduce the volume of a chamber using hook straps 151 and loops traps 150. As the chamber is rolled up to the desired amount of lift as indicated on indicator gauge 133, straps 150 and 151 are fastened. The side chambers are attached to the loop body of the buoyancy compensator by way of hook strap 152. Hook flap 161 closes loop pouch 160 that contains lead shot to neutralize the inherent buoyancy of the buoyancy compensator 85 so that ballast is not consolidated onto the weight belt. Keel weight 100 is shown on the top tank band 109. There are many ways that the chambers could be secured after being reduced in volume such as by buttons, snaps, zippers, pins, constricting bands, fabric flaps and fabric valves. The final result is that the diver can vary the volume of their buoyancy compensation chamber as required for a safe dive.

The side chambers 136 can be rolled to any point as indicated by the demands of the particular dive. Double sided velcro loop 150 connects with double sided hook 151. A piece of double sided velcro hook 152 attaches to the loop body of the buoyancy compensator. The cam buckle 101 of tank band 109 generates the pressure between the buoyancy compensator and the tank and secures the hook strap 152 from peeling off. In an emergency at the surface the reduced volume can be accessed by releasing the velcro valve straps 150 and 151. It is noted that the chamber behind the neck 134 is not accessible to being reduced.

SUMMARY, RAMIFICATIONS, AND SCOPE

Accordingly, the correct positioning of a very small amount of buoyancy can accomplish what five to ten times that same amount of buoyancy cannot, a single heads up righting moment that will protect the airway. After surviving the initial entry into the water, signaling search and rescue efforts can make the difference between life and death. Dual tragedy is the term applied to the death of the rescuer by a hypoxic victim, an inflatable float is one of the safest ways to approach a floundering victim. It can take hours for available life rafts to round up survivors, often victims who have survived the initial insult of entry perish within thirty minutes of hypothermia. The only solution to hypothermia is to remove the victim from the water whether they are waiting to be picked up by the life raft of it they are going to be spending an extended period at sea until land based search and rescue efforts arrive. The multi-function rescue product and raft comprised of a multiplicity of chambers,

constructed from the appropriate material, can be built into the heads up safety vest where it is safely stored until needed.

The principles of a heads up safety vest need to be modified for use underwater by separating out high lift surface flotation, incorporating a variable volume buoyancy compensation chamber that can be reduced to the lowest volume necessary for a particular set of dive gear and dive environment. The current invention makes great strides in reducing the emergency ascent rate and thus reducing the exposure to pulmonary barotrauma, arterial gas embolism as well as the chances of developing decompression sickness. The buoyancy of some air cylinders when empty and the use of a primary back mounted buoyancy compensator, require the addition of a tank compensating keel weight to assure the diver that with or without the deployment of the forward chamber that once the diver is at the surface, that their only inflatable product will roll them over and place their airway out of the water if they are unable to do so themselves. A third self rupturing emergency buoyant ascent chamber can be an option if the diver insists on using an underwater propulsion device. The incorporation of numerous rescue devices as integrated chambers in fluid communication with the power inflated dedicated buoyancy compensator, allows the user rapid access to rescue boards, distress markers, transport rafts, dive site markers, underwater markers, salvage devices, tender crafts and surf mater. This wide range of power inflatable products confers significant advances in water safety, survival and enjoyment.

FIGS. 15 through 25 illustrate a first alternative embodiment for a counterweight assembly 300 which generally includes a weight member 302 and means for attaching weight member 302 to assure reliable and consistent heads up position of the person at surface level. A first means for attaching weight member 302 embodiment includes a pair of vertical slots 304 and 306 defined by weight member 302 and a tank band or strap 320 which includes a first end 322 and a second end 324. A tank band connection member can be provided at first end 322 of tank band 320. Preferably, the connection member is a tensioning device such as a conventional cam buckle 330, however, such is not limiting and other attachment mechanisms, such as D-rings, hook and loop fasteners, magnets, suction cup devices, etc., are considered within the scope of the invention.

To properly attach weight member 302 to air tank 301 second end 324 is inserted through vertical slots 304 and 306, weight member 302 is properly positioned with respect to air tank 301 and tank band 320 is tightly wrapped around air tank 301 with weight member 302 properly positioned. Cam buckle 330 provides for attachment of second end 324 with first end 322 to maintain weight member 302 in proper position along tank 301. Weight member 302 is preferably secured such that the diver or user cannot remove or release weight member 302 during his or her underwater travels. This guarantees reliable and consistent heads up positioning of the diver at the water surface level in the event the diver becomes incapacitated.

A non-skid means can be provided to prevent weight member 302 from moving out of position with respect to tank 301. Preferably, the non-skid means is a non-compressible rubber or plastic member 328 sewn to the inside surface of tank band 320, however, other conventional non-skid means can be provided and are considered within the scope of the invention.

As seen in FIGS. 26 and 27, one or more suction cups 380 can be mechanically fastened into weight member 302 by

conventional means. Alternatively, a sheet of suction cups (not shown) can be glued or molded into weight member 302. The sheet of suction cups is provided to cover a majority of the interior surface of counterweight 300. The sheet of suction cups is provided with apertures which are shaped and aligned with vertical slots 304 and 306 and horizontal slots 314 and 316, described in detail below, so not to interfere with the insertion of tank band 320 or coupling strap 340, also described in detail below, through slots 304 and 306 or 314 and 316, respectively.

In either suction cup embodiment, the suction cups are provided to provide a quick attachment of weight member 302, as well as a quick removal means for weight member 302. The suction cups are particularly useful during training or practices where the exact amount of ballast for the diver or person is uncertain and various weight members 302 of differing weights are to be attached and detached from cylinder 301 until the proper amount of ballast (weight) required for the specific individual is determined. Without the suction cups, the trainer or person determining the proper amount of ballast (weight), has to repeatedly attach and detach various weight members 302 via straps 320 or 340 as described above, which is very time consuming. The use of suction cups provide a quick and accurate method for readily determining a proper weight member 302 for the individual.

Additionally, the suction cups are also useful for maintaining weight member 302 in proper position, while weight member 302 is properly secured by either tank band 320 or coupling strap 340 in conjunction with strap 360 of buoyancy compensator 359.

Alternatively, a hook and loop/pin/snap system along the tank's longitudinal axis would allow rapid determination of size and location by a dive master/instructor. Thus, a multitude of known attachment devices could be incorporated and utilized by a second person assisting the user for determining the proper size and location of the weight member for the specific user.

An alternative means for attaching weight member 302 embodiment includes a pair of horizontal slots 314 and 316 and a relatively small coupling strap 340 for joining weight member 302 to a conventional buoyancy compensator strap 360 which is provided for conventionally attaching air cylinder 301 to a conventional buoyancy compensator 359.

Coupling strap 340 includes a first end 342, a second end 344, an outer surface 346 and an inner surface 348. Preferably, hook and loop fastening means 350 and 352 are provided on inner surface 348 at first end 342 and second end 344, respectively. However, other conventional attachment means, though not preferred, can also be utilized and are considered within the scope of the invention. Coupling strap 340 can also be provided with a pull strap 354 at first end 342.

To properly attach weight member 302, cylinder or tank 301 is initially conventionally loosely attached to buoyancy compensator 359 in conjunction with strap 360 which utilizes a conventional cam buckle for its connection means. Once cylinder 301 is loosely attached to buoyancy compensator 359, first end 342 of coupling strap 340 is inserted between strap 360 and cylinder 301. Second end 344 of coupling strap 340 is inserted through horizontal slot 314 or 316 from behind weight member 302 and then back through the other horizontal slot 316 or 314, respectively, for attachment to first end 342 by mating of hook and loop fastening means 350 and 352. Strap 360, having weight member 302 attached thereto, is tightened around cylinder 301 in conjunction with its cam buckle as is conventionally known, to

EXHIBIT
Page 88 of 167 pages

US 6,530,725 B1

27

securely attaching cylinder 301 to buoyancy compensator 359. It is to be understood that the roles of ends 342 and 344 can be reversed with second end 344 being inserted through and between strap 360 and cylinder 301 and first end 342 being inserted through horizontal slots 314 and 316 for mating with second end 344.

Prior to tightening strap 360, weight member 302 is properly positioned with respect to cylinder 301 and preferably, the mating of first end 342 to second end 344 is positioned between buoyancy compensator strap 360 and cylinder 301. This attachment position prevents inadvertent detachment of ends 342 and 344 from each other, once strap 360 is properly tightened, thus, assuring that weight member 302 will remain properly secured.

A slight recess 319 on the interior aspect of weight member 302 is preferably provided when attaching weight member 302 by a coupling strap 340. As the cam buckle generates tension in the buoyancy compensator strap 360, the tension also pulls on coupling strap 340. This pulling on coupling strap 340, tightens the attachment of weight member 302 to strap 360. The secured and tightened strap 360 compresses the hook and loop attachment of ends 342 and 344, thus, preventing accidental release. The point where ends 342 and 344 are positioned between strap 360 and cylinder 301 protrudes outward slightly which is received within recess 319 of weight member 302, when weight member 302 is properly secured. Thus, recess 319 helps couple weight member 302 specifically to the exact shape of each tank or cylinder 301 so that there is no opening to ensnare objects underwater.

When removing weight member 302, strap 360 is loosened by conventional means, and tab 354 is pulled to break the attachment of ends 342 and 344 to each other, which allows weight member 302 to be removed. However, it is important to note, that weight member 302 is preferably secured such that the diver or user cannot remove or release weight member 302 during his or her underwater travels. This guarantees reliable and consistent heads up positioning of the diver at the water surface level in the event the diver becomes incapacitated.

The threading of the cam buckle, in conjunction with strap 360, is a complicated process. Thus, by providing slots 314 and 316 and coupling strap 340, weight member 302 can be removed without having to re-thread the cam buckle.

Preferably, buoyancy compensator strap 360, similar to tank band 320, is provided with a non-skid means to prevent tank 301 from moving out of position with respect to its attachment by strap 360 and assuring that weight member 302 remains properly placed with respect to tank 301. Also like tank band 320, in the preferred embodiment, the non-skid means is a non-compressible rubber or plastic member 363 sewn to the inside surface of strap 360.

Preferably, the radius of weight member 302 is the same as the cylinder or tank 301 to which it is attached to prevent snagging of various underwater objects, such as fishing lines, when a diver, having a tank 301 and counterweight assembly 300 attached to his or her buoyancy compensator, is moving underwater. Accordingly, weight member 302 is preferably configured specifically to tank 301's circumference and is provided with a feathered edge (rounded/tapered leading edge) to eliminate any gaps which might snag kelp.

Though the various counterweight assembly described above and below are discussed in conjunction with a buoyancy compensator, it should be understood that the counterweight assemblies can also be utilized with personal flotation devices such as life jackets and life vests. Thus, where

28

reference is made to a buoyancy compensator throughout the application, it is also intended to include other personal flotation devices such as the life jackets and life vests.

Weight member 302 can be provided with a soft coating to also prevent weight member 302 from sliding when properly attached, as well as increasing the adherence of weight member 302 and buoyancy compensator 359 to cylinder 301. The soft outer coating of weight member 302 also protects cylinder 301's protective and cosmetic coating from being scratched.

Weight member 302 is provided with a relatively thin flat profile which increases the total surface area between weight member 302 and cylinder 301 and increases the security of the attachment of buoyancy compensator 359 to cylinder 301. The lower profile is designed to provide less drag and less chance of snagging underwater objects such as kelp. Weight member 302 can be provided with a feathered edge to couple specifically to the exact shape of each tank or cylinder 301 so that there is no opening to ensnare objects underwater.

Preferably, weight member 302 can weigh approximately six (6 lbs) pounds. However, this weight amount is not limiting, and other weight amounts for weight member 302 can be utilized, as determined by a particular diver's needs, and are considered within the scope of the invention.

FIGS. 28 through 30 illustrate a second alternative embodiment counterweight assembly generally designated as reference numeral 400. Counterweight assembly 400 can either be utilized with conventional buoyancy compensator strap 360 or can be utilized in conjunction with a tank strap or band 420, which is similar to tank band 320. Counterweight assembly 400 consists of a flexible pouch member 430 and one or more weight members 460. Pouch member 430 is preferably constructed from a fabric material, and can be either slidably and removably attached or permanently attached to either tank band 420 or buoyancy compensator strap 360.

When removably attaching pouch member 430 to either tank band 420 or strap 360, a loop member 434 is preferably attached to the back of pouch member 430, by conventional means such as stitching, and either tank band 420 or strap 360 is inserted through loop member 434 until pouch member is properly positioned with respect to cylinder 301. Where strap 360 is utilized, pouch member 430 is preferably properly positioned prior to final tightening of strap 360 around cylinder 301.

Alternatively, two loop portions (not shown) can be provided each being attached at their respective first ends to pouch member 430 by conventional means such as stitching. The second outer ends of the loop portions can respectively be provided with attachment means such as hook and loop fasteners. When removably attaching pouch member 430 to strap 360 or tank band 420, the outer ends of the loop portions being disposed between strap 360 or tank band 420 and cylinder 301, where the loop portion outer ends mate to define a loop member. Once the outer ends are mating and properly positioned, strap 360 or tank band 420 is properly tightened sandwiching the outer ends between cylinder 301 and strap 360 or tank band 420 to prevent inadvertent releasing of the outer ends, as well as assuring proper positioning of pouch member 430.

When permanent attachment of pouch member 430 is desired, such attachment is preferably accomplished by conventional means such as stitching or sewing (FIG. 29). Preferably, the permanent attachment of pouch member 430 to tank band 420 or strap 360 is such that pouch member 430 is properly positioned when tank band 420 or strap 360 is tightened.

Pouch member 430 can be provided with a plurality of individual weight receiving pockets 432. Preferably, four (4) to eight (8) individual pockets 432 are provided. However, this number of pockets 432 is not limiting, and other pocket 432 amounts can be provided and are considered within the scope of the invention. Alternatively, pouch member 430 can be provided with large weight receiving area.

Individual weights 460, which act as ballast members, can be inserted into one or more of pockets 432 or into the large weight receiving area, depending on the amount of weight required. Alternatively one large hard weight (i.e. lead, steel etc.) or soft weight (i.e. sand, loose ballast, etc.) can be provided in the large weight receiving area. Weight members 460 are preferably constructed from lead, though other materials can be utilized and are considered within the scope of the invention.

The use of one or more weight members 460 allows for fine tuning of the amount of weight necessary for reliable heads up positioning at water surface level of an incapacitated diver. taking into consideration the diver's weight, equipment, etc. Thus, the exact amount of weight or ballast can be provided to assure that the user's airway will be protected in the event of an emergency.

A flap member 440 can be attached to pouch member 430 by conventional means such as sewing or stitching. In use, flap member is folded over and attached to pouch member 430 preferably by conventional means such as by the mating of hook and loop fasteners 435 and 437 disposed on at least a portion of an inner surface of flap member 440 and on at least a back outer surface of pouch member 430. However, other attachment means can be provided such as snaps, buttons, zippers, etc., and are considered within the scope of the invention. Flap member 440 prevents weight members 460 from inadvertently being removed from their placement within pocket member 432 or the large weight receiving area. Thus, when counterweight assembly is properly positioned, flap member 440 is compressed, to guarantee it remains in its closed position, by tank strap 420 or strap 360. Flap member 440 can be provided with a non-skid member 441, similar to the non-skid members discussed above.

Additionally, in lieu of inserting weight members 460 across in a horizontal manner, pouch member 430 can be constructed such that the weight members are inserted within pouch member 430 in a vertical fashion. Preferably, each individual weight member 460 weighs approximately two (2 lbs) pounds, though such is not limiting and other weight amounts can be utilized and are considered within the scope of the invention. Furthermore, weight members 460 can be symmetrical, however, such is also not limiting.

Pouch member 430 can be constructed from neoprene, spandex, canvas, nylon, or other conventional soft and flexible fabric materials. Furthermore, elastic or other stretch means can be incorporated into pouch member, to assure a tight and snug fit of one or more weight members 460 within pouch member.

In this embodiment, pouch member 430 is preferably secured such that the diver or user cannot remove or release weight member(s) 460 during his or her underwater travels. This guarantees reliable and consistent heads up positioning of the diver at the water surface level in the event the diver becomes incapacitated. This feature of not allowing the diver or user from having access to the weight members during his or her underwater travels is found in all of the tank mounted counterweight assemblies of the present invention, described above or below.

As seen in FIGS. 32 and 33, one or more individual weights 500 can be attached directly to conventional buoy-

ancy compensator strap 360 or to tank band 320. In this counterweight assembly embodiment, weight members 500 are provided with a slot 502 for insertion therethrough of either strap 360 or tank band 320. Similar to above, a non-skid means (not shown) can also be provided on either strap 320 or 360 or weight members 500 to prevent weight members 500 from moving out of proper position. Also similar to above, the number of weight members 500 provided is dependent on several factors such as diver's weight, equipment weight, etc. Weight members 500 are preferably constructed from lead or steel, though other materials can be utilized and are considered within the scope of the invention. Weight members 500 preferably weigh between one (1 lb) pound to three (3 lbs) pounds each. However, this weight amount is not limiting, and other weight amounts for weight members 500 can be utilized and are considered within the scope of the invention.

As seen in FIGS. 34 through 36, a weighted sleeve member 600 can be positioned along tank or cylinder 301 to provide ballast in order to assure heads up positioning at water surface level of an incapacitated diver. Weighted sleeve member 600 is tightly slid along cylinder 301 to its proper position with respect to cylinder 301. Weighted sleeve member may be fastened by conventional means such as bolting.

A flexible pouch member 620, similar to the various embodiments pouch member of described above and below, can also be provided in addition to weighted sleeve member 600. Pouch member 620 can be provided with one or more weight 630 receiving pockets 632. Pouch member 620 is preferably constructed from a fabric material and can include a flap member (not shown). Pouch member 620 is preferably disposed around sleeve member 600 and can be attached by conventional means such as hook and loop fastening members 622 or by buckle means. Thus, weighted sleeve member 600 can have a non-user releasable connection securing an additional counterweight assembly to weighted sleeve member 600. Furthermore, weighted sleeve member 600 can be positioned at the bottom of tank 301 for use in warm water.

Alternatively, a pouch member 650 (FIG. 36), can be provided which is constructed from a rigid material, such as plastic and is preferably constructed integral with sleeve member 600. Pouch member 650 can be provided with one or more weight 630 receiving pockets 652. Rigid receiving pockets 652 can be provided with holes in their bottom to push weight members 630 out after the dive. As receiving pockets 652 are constructed from a rigid material, preferably, the weight members to be inserted within, should correspond in shape to pockets 652. Furthermore, conventional cap means is preferably provided for each pocket 652 to prevent the weight members from falling out during the dive. Pouch member 620 or 650 and sleeve member 600 function similar to the other embodiment pouch members of the present invention. The lateral edge of weight members 630 can be modified to allow it to easily slide into tracks (pockets 652) built into or formed integral with weighted sleeve member 600.

FIGS. 37 through 39 illustrate another counterweight assembly embodiment generally designated as reference numeral 700. Counterweight assembly 700 includes a pocket member 710 which can be either permanently or removably fixed to buoyancy compensator strap 360 or tank band 320, in any of the methods previously described above, and a hard weight member 780 or soft weight member 790 disposed within a pouch member 740 with pouch member 740 being at least partially disposed within pocket member 710.

EXHIBIT
Page 90 of 111 pages

Pouch member 740 is provided with a quick release handle 754 which is attached to pouch member 740 by a strap member 770 and allows a person, other than the user, to remove pouch member 740 and weight member 780 or 790 from pocket member 710 when a diver or other swimmer is finished with his or her underwater travels. Normally a person standing on a boat, dock or other type of surface, pulls off the diver's equipment (including his or her buoyancy compensator 359 and attached air tank 301) while the diver remains in the water.

This removal of equipment makes it easier for the diver to climb onto the boat or dock. Buoyancy compensator 359 and air tank 301 typically weigh together approximately fifty (50 lbs) pounds. With the use of certain buoyancy compensators currently available, an attached weight member 780 or 790 may add up to approximately eighteen (18) to twenty (20) additional pounds to the amount of weight the person in the boat has to remove. The person in the boat normally bends over towards the water in order to reach the diver who is in the water. This position, seriously exposes the person's back to strains and pulls, as well as potential hernias. Individuals who work on dive boats are constantly lifting the equipment onto the boat, in such awkward position, throughout the day. Accordingly, any reduction in the amount of weight to be lifted each time, becomes significant when such tasks are performed on numerous occasions during one outing or continuously throughout the day.

Thus, by providing a quick release means for weight members 780 or 790, the person in the boat can initially remove weight members 780 or 790, thus, reducing the weight of the buoyancy compensator and air tank to be lifted by approximately up to eighteen (18) to twenty (20) pounds. This reduction in weight could help to prevent many back problems commonly experienced by persons removing the diver's equipment onto the boat or dock.

FIG. 39 illustrates the various steps of removing quick release weight member 780 or 790 from pocket member 710 by the person on the boat or dock. As previously mentioned, it is to be understood that weight members 780 or 790, as well as all of the counterweight assembly embodiments of the present invention, are positioned such that the weight members cannot be removed or released by the diver in order to assure that the diver is consistently maintained in a heads up position in the event he or she becomes incapacitated.

Pocket member 710 is shown having an outer surface 712. A hook and loop fastening means 714 is provided on outer surface 712 adjacent an open end of pocket member 710. A pocket flap member 716 is provided having an outer surface 718 and an inner surface 720. A first flap hook and loop fastening means 722 is provided on outer surface 718 and a second hook and loop fastening means 724 is provided on inner surface 720. Pocket member 710 can be provided with a perforated portion.

Pouch member 740 houses removable weight member 780 or 790. The weight member can be a sandbag (soft weight 790), lead weight (hard weight 780), or other appropriate ballast member which can be disposed within pouch member 740. A hook and loop fastening means 772 is provided on a first surface of strap member 770 and hook and loop fastening means 776 and 778 are provided on a second surface of strap member 770. A first end of strap member 770 is attached to pouch member 740 and a second end of strap member 770 is attached to handle means 754 both by conventional means. Handle means 754 includes a triangularly shaped gripping member 756 having a gripping surface 758.

Weight members 780 or 790 act as ballast means to assure heads up positioning of an incapacitated diver at water surface level and in use are disposed within pouch member 740 which in turn is disposed within pocket member 710 with strap member 770 and handle means 454 protruding out of pocket member 710. A portion of hook and loop fastening means 724 mates with hook and loop fastening means 778, hook and loop fastening means 772 mates with a portion of hook and loop fastening means 714, and a remaining portion of hook and loop fastening means 724 mates with a remaining portion of hook and loop fastening means 714, by folding flap 716 inward along a fold line 717. At this point, strap 770 is folded inward over flap 716 to allow hook and loop fastening means 776 to mate with hook and loop fastening means 772 to securely retain weight member 780 or 790 within pocket member 710, to assure consistent heads up positioning of an incapacitated diver, while allowing a person standing on a boat or dock to remove weight member 780 or 790 when the diver is ready to climb onto the boat or dock.

To remove weight member 780 or 790, the person on the boat or dock grabs handle means 754 at gripping surface 758 and pulls handle means 754 with a normal, but strong, tugging motion force, which nearly simultaneously breaks the attachment of fastening means 776 to fastening means 722, fastening means 714 to fastening means 724, fastening means 772 to fastening means 714, and fastening means 778 to fastening means 724, to allow weight member 780 or 790 to be quickly removed from pocket member 710. Once removed, the person on the boat or dock, merely drops weight member 780 or 790 and pouch member 740, on the boat or dock, respectively, where it can be properly redispensed within pocket member 710, when the diver or another prepares to enter the water again.

As seen in FIGS. 40 and 41, a combination of the previously described weight members can also be provided. As shown, counterweight assembly 300 is provided with a counterweight assembly 700 attached thereto. Weight member 302 provides a certain amount of ballast (weight), while the amount of ballast (weight member 780 or 790) provided within pocket member 710 varies depending on the weight of the diver and his or her equipment. Though, pocket member 710 is shown removably attached to weight member 302, it is to be understood, that the other pouch members described above, as well as one or more individual weights 500, can also be utilized in combination with weight member 302, and such other combinations are also within the scope of the invention. Furthermore, other combinations of counterweight assembly 700, counterweight assembly 300, individual weights 500 and the other pouch members described above can be provided and are all considered within the scope of the present invention.

To attach pocket member 710, or the other pouch members, tank band 320 is inserted through one of the vertical slots 304 or 306 of weight member 302, through a loop member attached to the back of pocket member (the loop portions described above could also be utilized), through the other vertical slot 306 or 304, respectively, and then tightened by conventional means, such as D-rings members, buckle means, etc, as described above.

Where weight member 302 is attached with buoyancy compensator strap 360, if loop portions are provided, the loop portions can be inserted through horizontal slots 314 and 316 and attached to each other, in lieu of providing coupling strap 340. Thus, in this embodiment, the loop portions provide the mechanism for attaching both weight member 302 to cylinder 301 and pocket member 710 to weight member 302.

It should also be understood in some applications, more than one of the same type of weight member, described above, may be utilized. For example, a first weight member 302 could be attached relatively high with respect to cylinder 301 and a second weight member 302 could be attached relatively low with respect to cylinder 301.

Furthermore, the vertical positioning of any of the weight members described above can be easily adjusted between dives or possibly by a person, other than the diver, during the dive. The weight member and tank band 320 are infinitely adjustable along the length of the horizontal axis. The ability to move tank band 320 and the attached weight member up and down the tank allows for optimal position of the weight member. This in turn allows the angle of the hyperextension of the "distressed" diver's neck at the surface to be accurately adjusted for optimal airway comfort. Thus, tank band 320 can be quickly and securely adjusted to attach the appropriate weight member in the appropriate position in response to any specific set of dive gear or dive environment.

A warm water diver may be diving with a minimal weight belt (i.e. four (4) to ten (10) pounds). Some divers may feel that attaching six (6) pounds of non-releasable ballast to their air cylinder 301 would result in a significant reduction in the amount of releasable ballast at depth. In order to incorporate the critical ballast counterweight (weight member) while preserving the diver's current releasable weight, the diver can use an offsetting buoyant means, fixed or releasable. The diver that requires a four (4) pound counterweight (weight member) to provide reliable airway protection can add a four (4) pound buoyant pad to protect their tail bone from the tank, fill the space between the small of the back and their tank or use the buoyant material to pad the thorax or their head. The foam can be alternatively attached to the front of the buoyancy compensator where it can be released in the event of an uncontrolled emergency (i.e. ascent due to accidental loss of weight at depth as might occur if the weight belt is snagged). The foam on the front would also increase the strength of the face up righting moment at the surface as might be desired by the beginning diver.

It is notable that if the counterweight is large enough it will overcome all other righting moments. The larger the ballast the stronger the righting effect. The balance is that cylinder 301 is already heavy, at the point of barely manageable. The combination of the forward buoyant means and four (4) to eight (8) pounds of ballast in the counterweight keeps the total system light enough that it can be comfortably maneuvered. If the forward chamber is left at the surface to protect the diver from boat traffic then the counterweight must be approximately doubled to preserve the heads up safety feature. If the counterweight is large enough, it can act alone to right the diver. Its key requirement is that it be located exactly opposite the diver, easily adjusted to maintain that position. A securely attached counterweight can be used to retrofit existing buoyancy compensators, as long as they have an adherent element to assure that the counterweight will not slide from position.

The counterweight is critical in balancing out the entire set of dive gear so that in an emergency the diver's gear provides a single stabilized righting moment that places the distressed divers airway out of the water.

The counterweight embodiments described above (FIGS. 15 through 41) can be relatively easily incorporated into other products, such as any and all other life vests, life jackets, etc. Thus, the life jacket or other personal flotation

device (collectively referred to as "life jacket") can be provided with a ballast/weight member attached to the back of the jacket, which as a counterweight member to provide angular momentum in rolling the diver or other wearer over in the water, such that the diver floats face up in the water. Preferably, the counterweight is attached posterior central.

A conventional life vest/life jacket can be comprised of inherently buoyant material, such as (1) kapok, closed foam; (2) mixed inherently buoyant material and inflatable ("hybrid" personal flotation device"); and (3) purely inflatable design. All of these design of a lifesaving buoyant means are improved by the addition of the ballast/counterweight. Preferably, the counterweight is able to be varied in size and position depending on the other equipment worn by the user and the user's anatomy. Typically the counterweight is between three (3) and six (6) pounds and is securely attachable to the life jacket adjacent and between the neck and lower back area of the user.

Furthermore, a conventional air tank or cylinder can have a weight member constructed integral with the tank if the intended wearer knows the specific amount of counterweight he or she requires, and the exact location of the weight member with respect to the air tank.

Additionally, where steel tanks or cylinders are utilized, a weight member having magnet means associated there with can be provided for directly attaching the weight member to the tank. This use would only be for training purposes and/or for determining the proper amount of weight, as well as the proper location of the weight on the tank, for the specific individual. This attachment embodiment would not be used during normal dives and underwater travels, as there is a chance that the weight member may move or inadvertently fall off. However, the weight member could also be provided with a strap, to provide a second attachment means for the weight member, as well as providing a secure attachment.

The counterweight allows for the application of ballast mediated airway protection to enhance surface airway management and promote self sufficiency. The reliable protection of a distressed diver's airway depends on the ballast not changing position in any of the three axis (up, down or around cylinder).

The instant invention achieves many critical features including providing that the weight be permanently attached, so that in an emergency it cannot be dropped. Since the weight member (counterweight) must be small enough to not compromise surface safety, it must be located on the back of the life jacket or on the back of the cylinder exactly opposite the diver where it generates the maximal rotational energy per pound of weight, rotational energy desperately needed to repeatedly turn the unconscious diver over onto their back against minor righting moments caused by limbs, variations in body density, and attached gear. In particular, if the victim is near heavy surf where the waves can flip a victim over onto their face, a strong heads up righting moment is essential. It should be understood that references to a "victim" include, but are not limited to, water accident victims and/or diving accident victims.

The counterweight assembly utilized is responsible for initiating the righting moment, and supplies the rotational energy needed to roll the victim over onto their back thereby assuring that the victim's face will be out of the water regardless of the angle of entry. Once the diver has reached the surface, the counterweight, in conjunction with the dynamics of a limp unconscious body, will oppose any tendency for the waves to roll the victim over into a face down position that would compromise the airway. In

EXHIBIT D
Page 28 of 41 pages

US 6,530,725 B1

35

summary, the counterweight assembly provides lateral stabilization of the water accident victim or diver (victim), and opposes rotational motion of the waves from over turning the victim into a face down position, but in the event that occurs, the counterweight assembly will automatically flip the victim back over onto their back, reestablishing the heads up orientation.

When an air cylinder is attached to the life vest or buoyancy compensator, the tank compensating counterweight becomes critical. If the victim is lying face down at the surface and goes limp, the counterweight will roll the diver over onto their back, stabilizing the diver's airway out of the water. The size of the weight member selected is in proportion to the type and size of life vest or size of buoyancy compensator and cylinder and whether the water is fresh or salt. The cylinder when empty is neutral to slightly negative, but lacks sufficient rotational energy to roll the victim over onto their back. The counterweight assembly in other words compensates for imbalances in the life vest, buoyancy compensator or the buoyancy shifts of the life vest or buoyancy compensator or the diver's air cylinder. If the cylinder remains negative when empty then the weight member can be smaller but still must generate sufficient angular momentum to offset the secondary righting moments generated by an imbalanced weight belt and attached gear or bladders. If the counterweight assembly is used as an adaption to existing vest style buoyancy compensator, then it has to be strong enough to overcome the side righting movements generated by the common practice of using buoyancy under the arms.

Central to the weight member's design is that it be made of a very dense material such as lead, and be located exactly opposite the diver on the back side of the life vest or the tank. Traditionally the buckle that generates pressure on the belt that attaches the buoyancy compensator to the tank is located in the center at the back of the tank. Because the posterior central position is so critical for the performance of the counterweight assembly, the buckle has to be moved off center. This shift in the cam buckles location results in a slight inconvenience in terms of reduced access but is necessary to preserve the critical location and therefore the righting moment of the compensating counterweight assembly.

Drowned divers are often found with their weight belts still on. Usually the weights are located along the waist and the amount runs from a couple of pounds to more than forty pounds. As the amount of weight increases, the weight member needs to be located higher up the air cylinder to offset the placement of the weight belt. A dual tank band (providing two weight members) allows for a wide variation of weight placement.

The weight member can also be incorporated into the metal of the cylinder, adhered to the cylinder, enclosed in a covering of any sort, or even attached with magnetism. A pouch or cylinder can be used to contain lead shot or beach sand as long as it is non-releasable and ideally located along the longitudinal axis of the cylinder and thereby serves to generate the heads up righting moment, with the least amount of weight. The various weight member embodiments, described above, guarantee a single surface position every time. That surface position being heads up.

The inclusion of a couple of pounds of weight integrated into the tank band of the buoyancy compensator will allow the diver to overcome numerous minor righting moments that can place the airway of the exhausted or distressed diver under the water leading to drowning, the major cause of death in the sport of diving.

36

The various counterweight embodiments provide for ballast mediated airway protection, namely, the protection of the diver's airway at water surface level, particularly in an emergency when the diver is unable to protect his or her airway. The various present invention counterweight assemblies reduce the current problem of airway submersion which normally leads to shallow water drowning, the number one cause of recreational diver fatalities.

The attachment of the buoyancy compensator to the tank has always created problems. A cam buckle is provided at the end of the strap to generate tension in the strap. The strap which attaches the tank to the buoyancy compensator, stretches when wet, which can cause the tank to slide down if not out. Thus, the critical ballast compensating counterweight (weight member), in addition to rolling the distressed diver over to protect his or her airway, through increasing the surface area for attachment, serves to markedly improve the attachment of the buoyancy compensator to the tank.

Thus, the present invention illustrates the use or attachment of a relatively small, non-releasable weight, which is applied to a variety of positions along the back of an air tank. The location at the back of the tank allows the size to be reduced to its minimum and still be able to provide reliable airway protection. In warm water the weight is provided relatively lower with respect to the air tank. In cold water where the diver has significant ballast already attached, the weight member is moved relatively higher with respect to the air cylinder towards the head to maintain optimal airway protection. The positioning of the weight member along the back of the tank, optimizes the angular momentum generated per unit of weight. The use of the smallest amount of weight possible to provide airway protection allows the warm water diver, who is by definition already using minimum weight.

With the use of a weight member as described above, from any position a distressed diver can be rolled over onto their back, repeatedly if necessary, with their neck hyper-extended and their airway positioned free and clear. The distressed diver is provided with ballast mediated airway protection which allows only a single, stable, surface position. Thus, when the diver cannot protect their airway, they can count on their counterweight assembly to act as a self rescue device providing emergency heads up surface flotation. Self rescue requires that at all times throughout the entire dive or underwater travel that the diver's gear is balanced such that their airway will not suddenly become vulnerable to submersion solely because they have become a couple of pounds out of balance in the last minutes of the dive or underwater travel due to the loss of air.

The above described counterweight assemblies roll the diver over, out of his or her side high airway submerging position and onto his or her back when the diver is unconscious. Accordingly, from any position the diver is rolled over onto their back, neck hyper-extended as it drops back, opening the airway. A diver in balance has a single stable airway protective righting moment, while a diver out of balance is susceptible to airway submersion and shallow water drowning.

By it's variable position, high or low, the above-described counterweight assemblies also assists in balancing all of the buoyancy and ballast attached to the diver, creating improved airway support for the distressed diver, from the beginning through the end of their dive or underwater adventure. Diver airway protection is provided regardless of whether the diver's gear is attached or dropped in part or in whole, as may occur in an emergency. The counterweight

EXHIBIT B
Page 24 of 111 pages

assemblies are designed to compensate for loss ballast or shift in balance to extend airway protection throughout the dive or underwater travels. Even if the diver is originally face down and unconscious at the surface, the counterweight assembly, when properly positioned tends to almost immediately right the diver face up, thus, protecting the diver's airway should such diver lose consciousness on the surface.

Additionally, a variable displacement device can be provided for providing additional buoyancy to the diver and his or her gear to offset any excess ballast that must be attached to acquire airway protection through ballast mediated airway management as described above.

Some divers, in particular warm water tropical divers, may dive with very little ballast. On occasion, the diver requires a tank mounted ballast that exceeds the amount of ballast needed to submerge. Some reasons why this is required includes (1) diver anatomy (i.e. large "Barrel Chest"); (2) composition of the diver's cylinder (i.e. aluminum); (3) large displacement buoyancy compensator may require up to eighteen (18) to twenty (20) pounds of tank mounted counterweight to provided airway protection yet only require approximately seven (7) pounds to submerge while diving in a bathing suit in warm water; (4) diver wishes to retain the entire amount of releasable ballast so he or she can quickly acquire a net positive surface flotation by dropping his or her weight belt. In such situations the addition of buoyancy will allow the diver to retain his or her releasable weight belt while acquiring the ability to self rescue, as described above, i.e. protect his or her airway from submersion if the diver becomes unconscious. Preferably, the buoyancy added is non-compressible which can occur through the use of a rigid container built into the diver's buoyancy compensator back pack.

Thus, the buoyancy means is attached to the diver/gear to offset the required airway protective tank mounted ballast (weight member). Preferably, the buoyant means is a rigid, non-compressible means for the provision of a specific amount of buoyancy, such as a non-compressible foam with permanent flotation qualities or fixed buoyancy bladder with adjustment inner valve for custom sizing to diver's buoyancy needs. Other alternative embodiment include a closed cell foam. However, with the use of a closed cell foam, as the diver submerges the bubbles in the foam compress, thus, reducing the buoyancy and requiring air to be added to the diver's buoyancy compensator jacket. The added air needs to be vented on ascent.

The buoyancy means preferably has a variable volume to allow for volume adjustments specific to the diver/dive environment. Additionally a single or multiple buoyant means can be provided and arranged to enhance surface flotation attitude.

As seen in FIG. 44, a training device for a tank mounted counter weight member is shown and generally references as device 800. A dive instructor during training, such as pool training, needs to individualize the size and location of the tank mounted counter weight member for each student (diver). To facilitate this time consuming process a longitudinal attachment means 800 is affixed to tank 301 with a quick release coupling means, such as quick side release buckles 802, thus, allowing for rapid attachment and adjustment of size and position of weight member(s) 820 which are housed in sleeve members. Hook and loop fastening means is disposed on at least a portion of the outer surface of the sleeve members for mating with hook and loop fastening strips 804 and 806 associated with training device 800.

The very security that is demanded of the tank mounted counter weight member when used as a life saving means complicates its rapid change and adjustment. As a pool training aid, speed of adjustments is more important than security. As such, training device 800 can be preferably clearly marked with a warning label stating that the device is not to be used for diving.

The vertical tank mounted attachment means can be secured by a wide variety of mechanical means, including, magnetic, zippers, snaps, spring loaded pins, hook and loop fasteners, etc. For example, a fabric jacket having a strip of hook and loop fastening means attached along its length can be provided. Weights in specific sizes can be quickly affixed in combination to establish the correct size, then adjusted vertically to optimize the exact surface flotation position for hyperextension of the diver's neck. The weights are not limited to any specific, but preferably approximately one (1) or two (2) pounds each.

Training device 800 can be preferably provided with a vertical index 810 which identifies location, such as a measurement means from the bottom of tank 301. Thus, the instructor can inform the student of the exact location where the weight member should be attached to tank 301, as well as the exact amount of weight required at such location.

The fabric jacket can also be secured by a wide variety of means. Preferably, hook and loop fastening means is provided to allow the jacket to be easily attached to a wide variety of cylinder diameters. One or more adjustable locking belts can be provided for use with large tank mounted counter weights, which may be required with certain technical buoyancy compensators. The jacket may also be secured by a variety of other means such as belts, buckles, zippers, snaps, etc. Furthermore, the inside coating of the fabric is preferably of a high coefficient of friction to reduce any tendency of the jacket to slip or slide from proper position during adjustment and testing of various tank mounted counter weight member.

FIGS. 45 and 46 illustrate a quick disconnect connector embodiment generally designated as connector 900. Connector 900 generally includes a male member 910 associated with a lifting device 902 and a female member 930 commonly associated with an inflating hose member of a conventional buoyancy compensator (not shown). Typically, lifting device 902 is deployed at depth. Lifting device 902 can be any type of device which contains a flotation chamber, including, raft 96 shown in FIG. 10. When raft 96 is the intended lifting device, male member 910 replaces a conventional male member 192 (FIG. 10) and which is shown in greater detail as conventional male member 980 (FIG. 47).

With the use of a conventional connector (FIG. 47), male member 980 is provided with a groove member 982 for a locking attachment with female member 930, when the intended lifting device is to be inflated (i.e. emergency situation). Once male member 980 is properly connected to female member 930, an activating member 984 presses a Schrader valve 932 disposed within an internal passageway 934 which extends through female member 930 from its first end 936 to its second end 938. The activation of Schrader valve 932 allows air to flow into the flotation chamber of the lifting device for inflation purposes.

However, with the connection of male member 980 to female member 930, the user (diver) is also attached to the lifting device. Under pressure it is often difficult to release male member 980 from its locking attachment to female member 930. Thus, as the lifting device begins to ascent, the

EXHIBIT B
Page 94 of 167 pages

diver (user) is placed in a position of uncontrolled ascent, possibly, leading the diver to one or more of the dangerous conditions described above.

As seen in FIGS. 45 and 46, male member 980 is replaced with a male member 910. Male member 910 includes a first end 912, a second end 914 and an internal passageway 916 extending through said male member 910 from first end 912 to second end 914. Male member is not provided with a groove member to avoid the locking problems described in the previous paragraph. Male member 910 can also be provided with an outer circular flange member 918 and a Schrader valve activating bridge member 920.

In use, male member 910 is received within internal passageway 934 of female member 930 until flange member 918 abuts an outer first end 936 of female member. Thus, flange member 918 acts as a stop means to properly position the first end of male member 910 within internal passageway 934 of female member 930. This positioning of male member 910 with respect to female member 930 allows bridge member 920 to activate Schrader valve 932 to allow air to flow within a flotation chamber of lifting device 940.

Male member 910 is slightly smaller in outer diameter as compared to the inner diameter of internal passageway 934. This allows male member 910 to be snugly and tightly received and maintained within internal passageway 934 of female member 930, while at the same quickly and easily releasable. Lastly, outer flange member 918 also serves as a gripping means to quickly remove male member 910 from within internal passageway 934 of female member 930 once the flotation chamber of lifting device 902 is properly inflated or in the event of an emergency.

The instant invention has been shown and described herein in what is considered to be the most practical and preferred embodiment. It is recognized, however, that departures may be made therefrom within the scope of the invention and that obvious modifications will occur to a person skilled in the art.

We claim:

1. A counterweight assembly for providing enhanced heads up surface positioning of a person, said counterweight assembly comprising:

a weight member; and

means for attaching said weight member to a cylinder, the cylinder adapted to be attached to the person, said means for attaching and said weight member attached at a position on said cylinder where the person cannot remove said weight member while the cylinder is attached to the person;

wherein the attachment position of said weight member on the cylinder allows the weight member to rotate the person to ensure heads up surface positioning if the person becomes incapacitated.

2. The counterweight assembly of claim 1 wherein said means for attaching is a flexible pocket member attached to a tank band, said tank band wrapped and attached tightly around the cylinder, wherein said weight member is disposed within said pocket member.

3. The counterweight assembly of claim 2 wherein said flexible pocket member is permanently attached to said tank band.

4. The counterweight assembly of claim 2 wherein said flexible pocket member is removably attached to said tank band.

5. The counterweight assembly of claim 2 wherein said flexible pocket member is divided into a plurality of weight receiving sections.

6. The counterweight assembly of claim 2 wherein said flexible pocket member has a flap member.

7. The counterweight assembly of claim 6 further including a releasable pouch member, said pouch member attached to a handle member, said weight member disposed within said pouch member, wherein said handle member is disposed out of said pocket member when properly assembled.

8. A counterweight assembly for providing enhanced heads up surface positioning of a person, said counterweight assembly comprising:

a weight member; and

means for attaching said weight member to a cylinder, the cylinder attached to the person, said means for attaching and said weight member attached at a position on said cylinder where the person cannot remove said means for attaching and said weight member while the cylinder is attached to the person;

wherein the attachment position of said weight member on the cylinder allows said weight member to rotate the person to ensure heads up surface positioning if the person becomes incapacitated.

9. The counterweight assembly of claim 8 wherein said means for attaching is a flexible pocket member attached to a tank band, said tank band wrapped and attached tightly around the cylinder, wherein said weight member is disposed within said pocket member.

10. The counterweight assembly of claim 9 wherein said flexible pocket member is divided into a plurality of weight receiving sections.

11. The counterweight assembly of claim 9 wherein said flexible pocket member has a flap member.

12. The counterweight assembly of claim 11 further including a releasable pouch member, said pouch member attached to a handle member, said weight member disposed within said pouch member, wherein said handle member is disposed out of said pocket member when properly assembled.

* * * * *

EXHIBIT B
Page 11 of 11 pages

EXHIBIT C

J06558082B1

(12) **United States Patent**
Courtney et al.

(10) **Patent No.:** US 6,558,082 B1
 (45) **Date of Patent:** *May 6, 2003

(54) **COMBINED BALLAST AND SIGNALLING DEVICE FOR A PERSONAL FLOTATION DEVICE**

4,858,204 A	*	8/1989	Holston et al.	405/186 X
5,106,236 A	*	4/1992	Hancock et al.	405/186
5,199,820 A	*	4/1993	Nicklo	405/186
5,400,736 A	*	3/1995	Gold	116/26
6,030,147 A	*	2/2000	Bowden	405/186

(76) Inventors: **William L. Courtney**, 1990 Hwy. One, Elk, CA (US) 95432; **Robert Manuel Carmichael**, 940 NW. 1st St., Ft. Lauderdale, FL (US) 33311

OTHER PUBLICATIONS

Jim Walker, Sea Quest Quickdraw BC, Where Up Meets Down, *Skin Diver Magazine*, Apr. 1991, *Best Seller Series*, Buoyancy Compensators.

(*) Notice: Subject to any disclaimer, the term of this patent is extended or adjusted under 35 U.S.C. 154(b) by 0 days.

* cited by examiner

This patent is subject to a terminal disclaimer.

Primary Examiner—Thomas B. Will
Assistant Examiner—Tara L. Mayo
 (74) *Attorney, Agent, or Firm*—Malin, Haley & DiMaggio, P.A.

(21) Appl. No.: **09/641,932**

(22) Filed: **Aug. 18, 2000**

Related U.S. Application Data

(57) **ABSTRACT**

(63) Continuation-in-part of application No. 09/618,333, filed on Jul. 18, 2000, which is a continuation-in-part of application No. 09/225,892, filed on Jan. 4, 1999, which is a continuation of application No. 08/645,206, filed on May 13, 1996, now Pat. No. 5,855,454.

A counterweight assembly is provided to enhance heads up surface positioning of a person. The assembly includes a weight/ballast member strategically disposed on a cylinder/tank worn by a diver during a dive. The weight member can be attached by several different embodiments. Preferably, the weight member is attached such that the diver cannot release or adjust the weight member while he or she is diving. The weight member rotates the person to ensure heads up surface positioning in the event the person becomes incapacitated. Also provided are several other water safety and survival devices. Also disclosed is a combined ballast and signaling device preferably neutralized by attachment to an eccentrically buoyant personal flotation device.

(51) Int. Cl.⁷ **B63C 11/02**
 (52) U.S. Cl. **405/186**; 116/26; 441/89; 441/114; 441/129
 (58) **Field of Search** 405/185-187; 441/40, 80, 88, 92, 96, 108, 114, 115, 129, 89; 116/26

(56) **References Cited**

U.S. PATENT DOCUMENTS

3,967,459 A * 7/1976 Denis 405/186

16 Claims, 34 Drawing Sheets

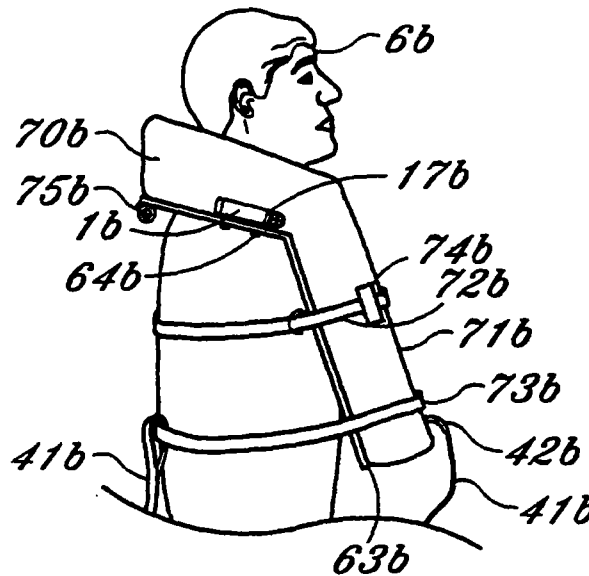

U.S. Patent

May 6, 2003

Sheet 1 of 34

US 6,558,082 B1

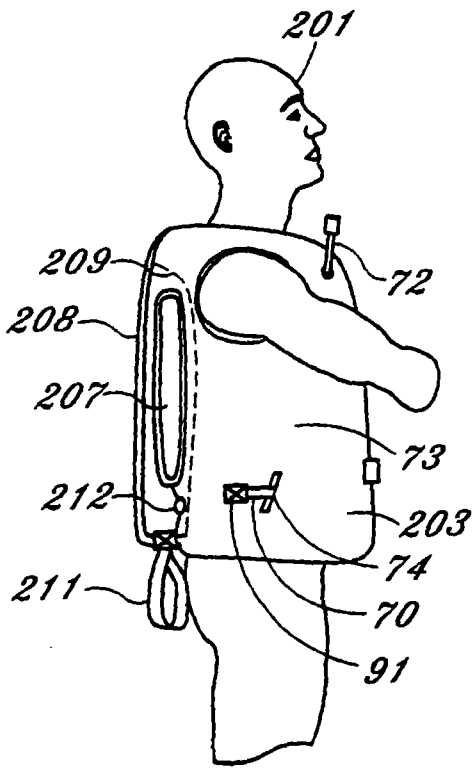

Fig. 1

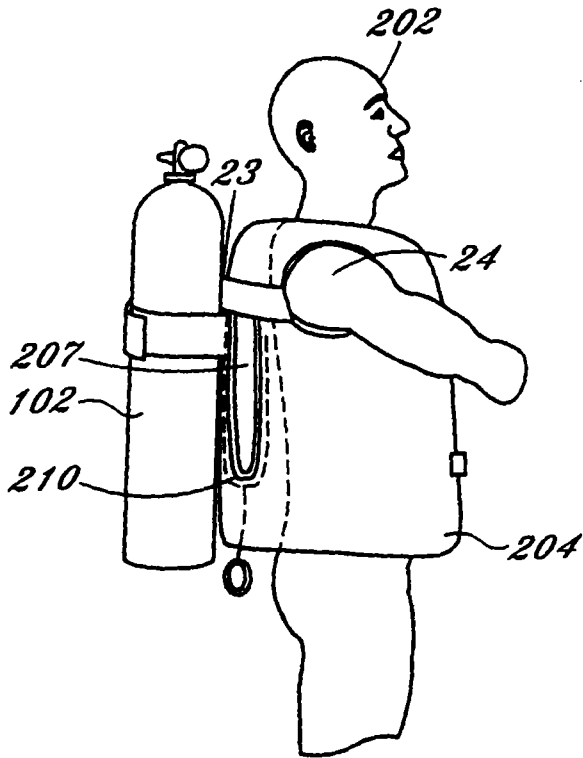

Fig. 2

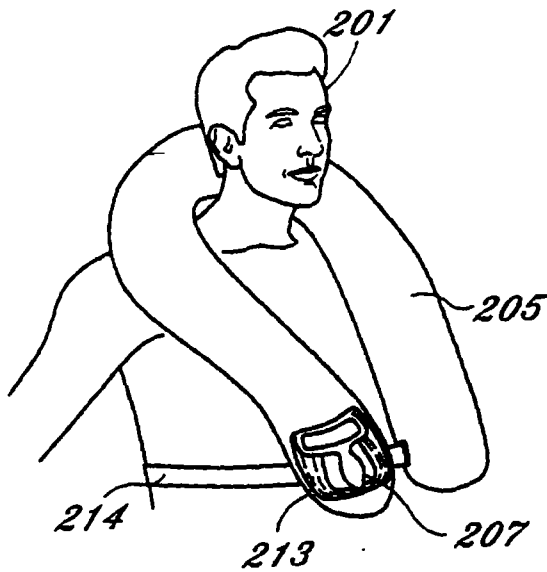

Fig. 3

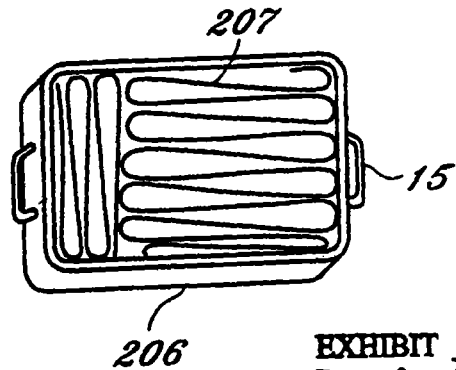

Fig. 4

EXHIBIT C
Page 2 of 167 pages

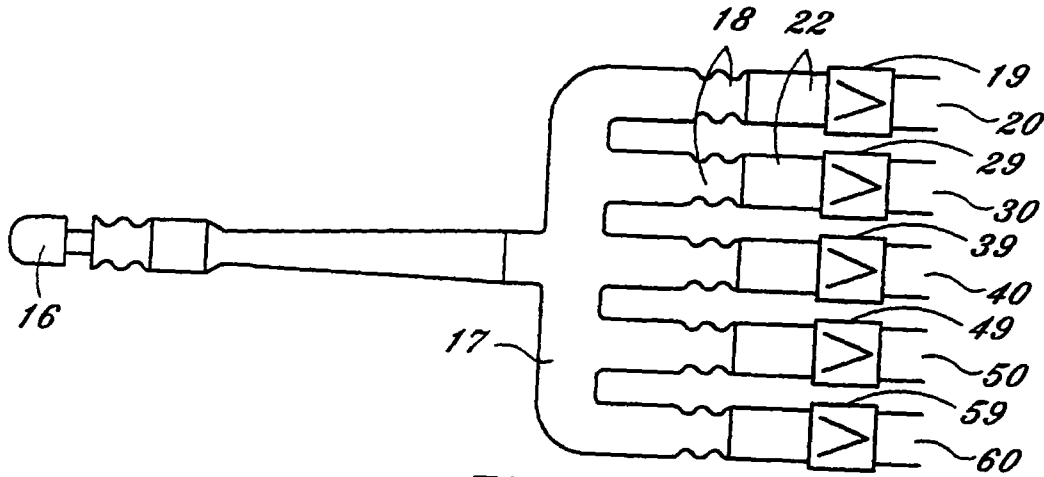

Fig. 5

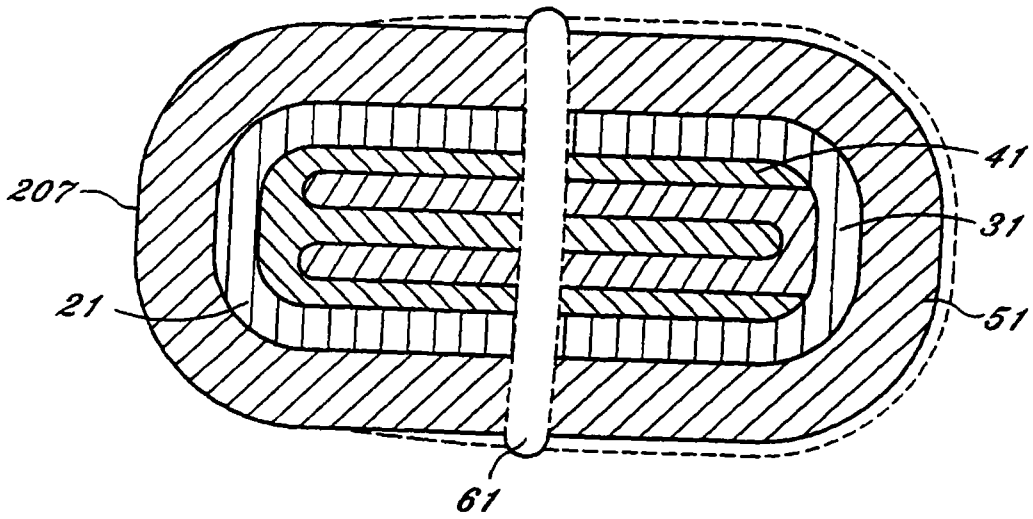

Fig. 6

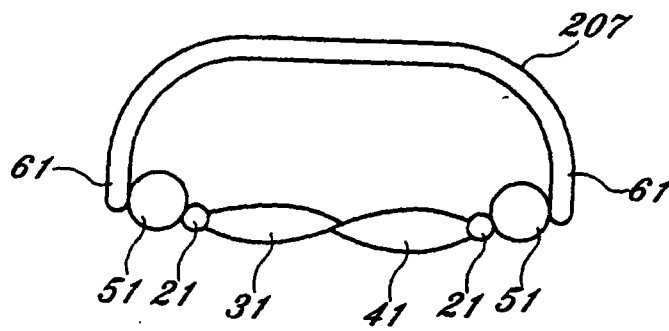

Fig. 7

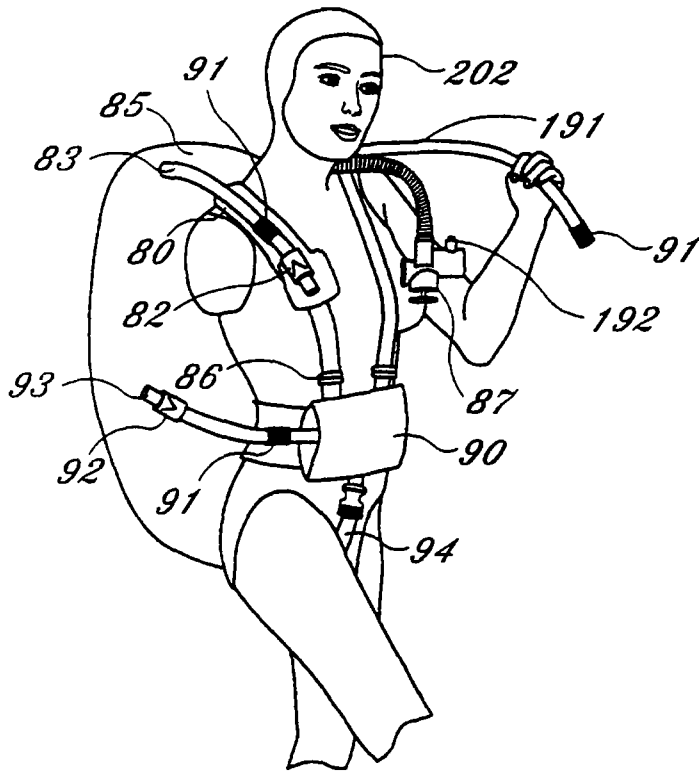

Fig. 8

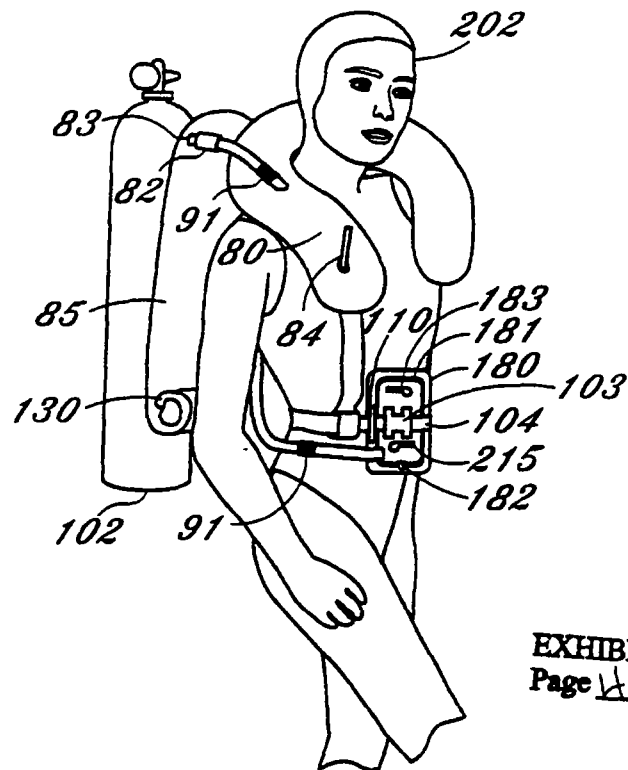

Fig. 9

EXHIBIT C
Page 4 of 17 pages

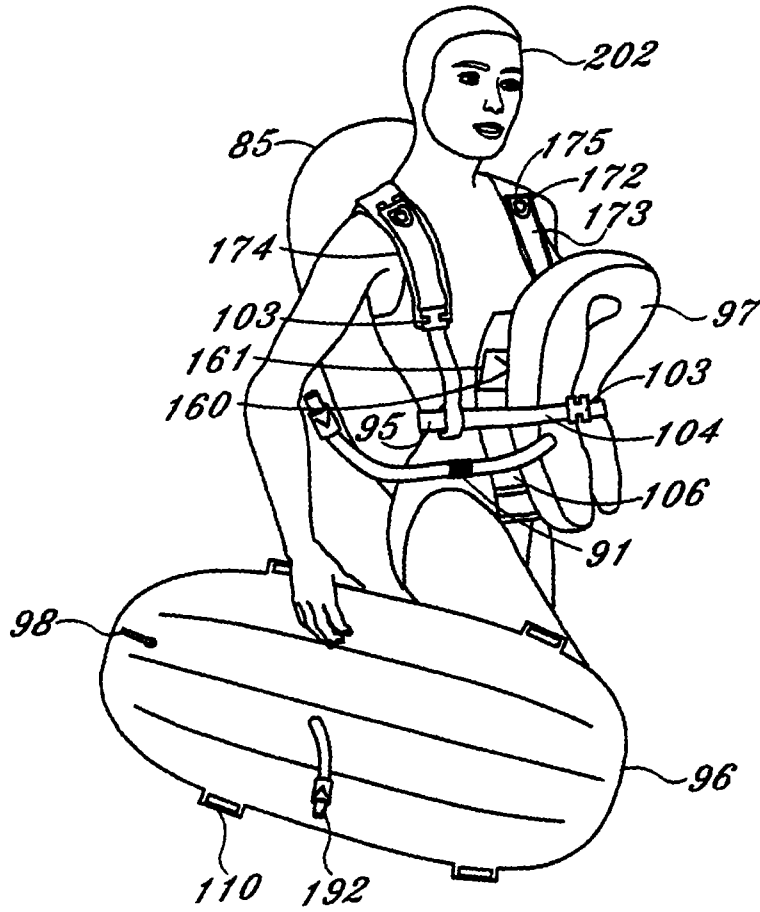

Fig. 10

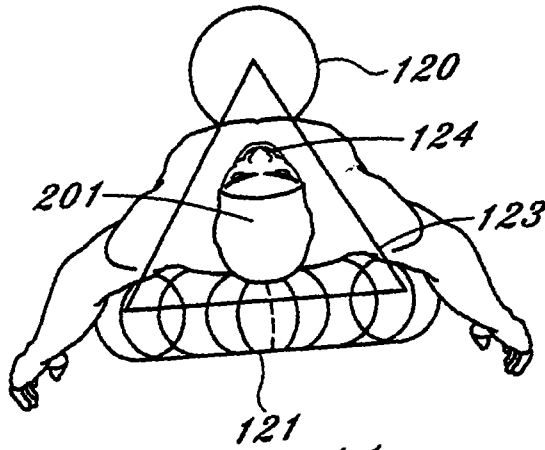

Fig. 11

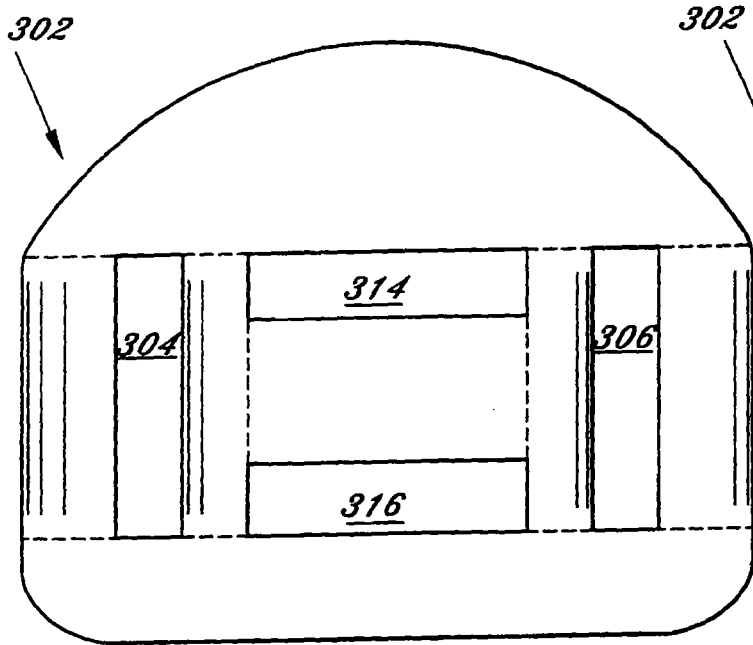

Fig. 17

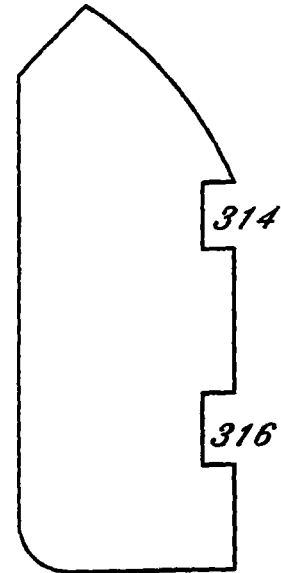

Fig. 19

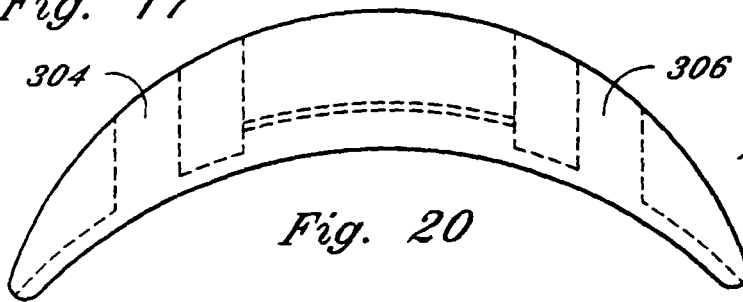

Fig. 20

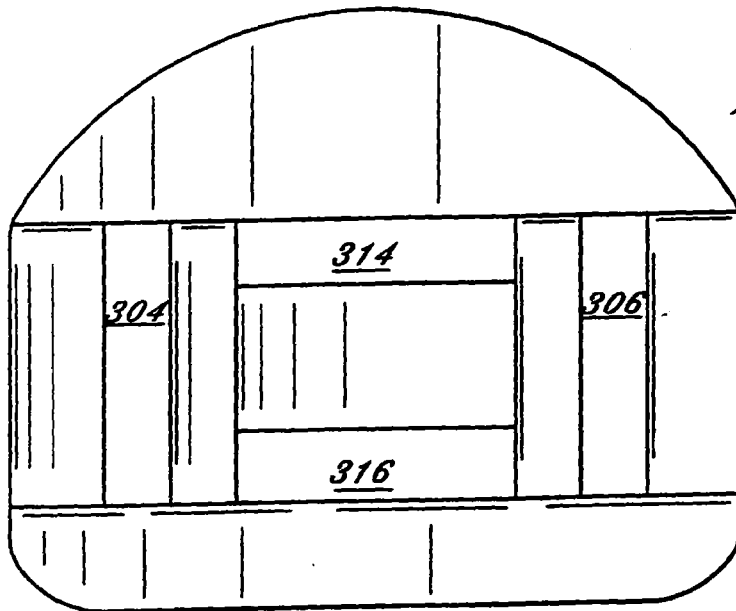

Fig. 18

EXHIBIT C
Page 7 of 67 pages

U.S. Patent

May 6, 2003

Sheet 9 of 34

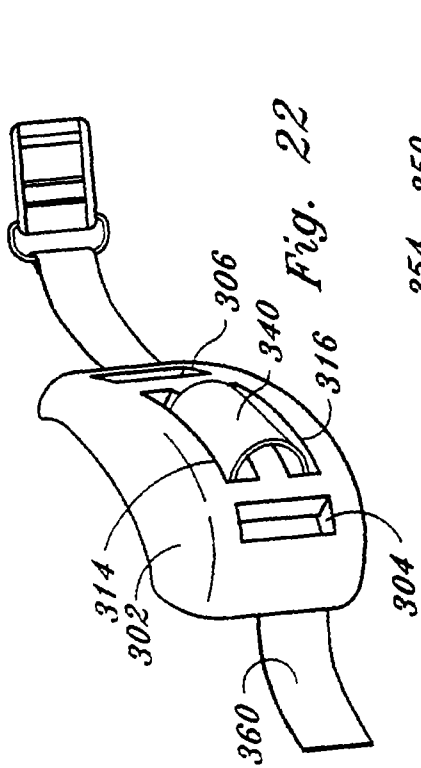

Fig. 22

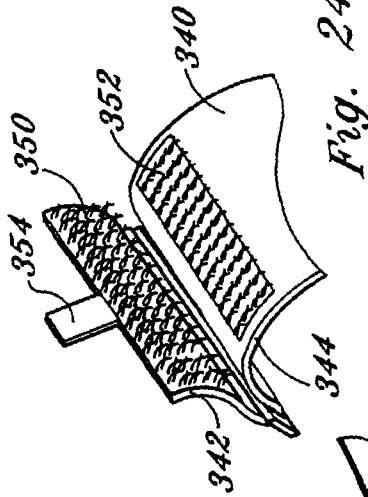

Fig. 24

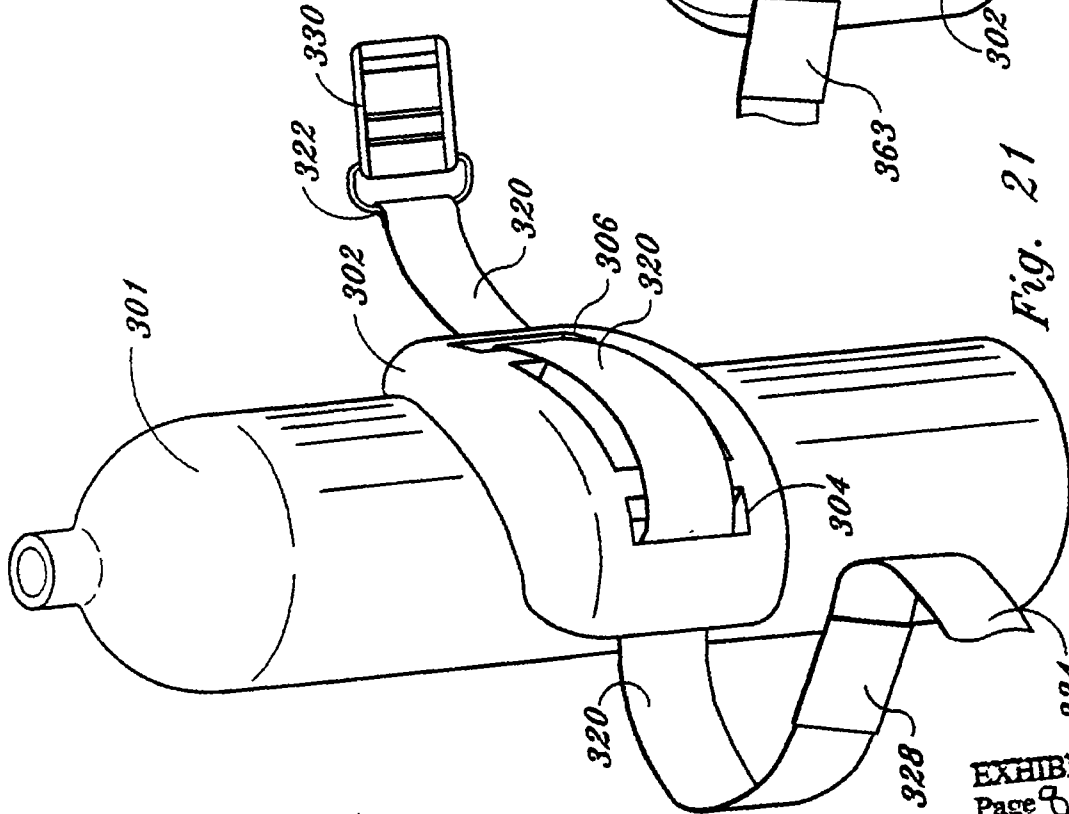

Fig. 21

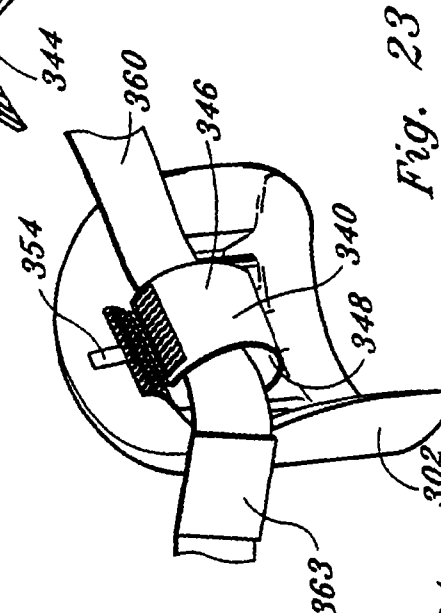

Fig. 23

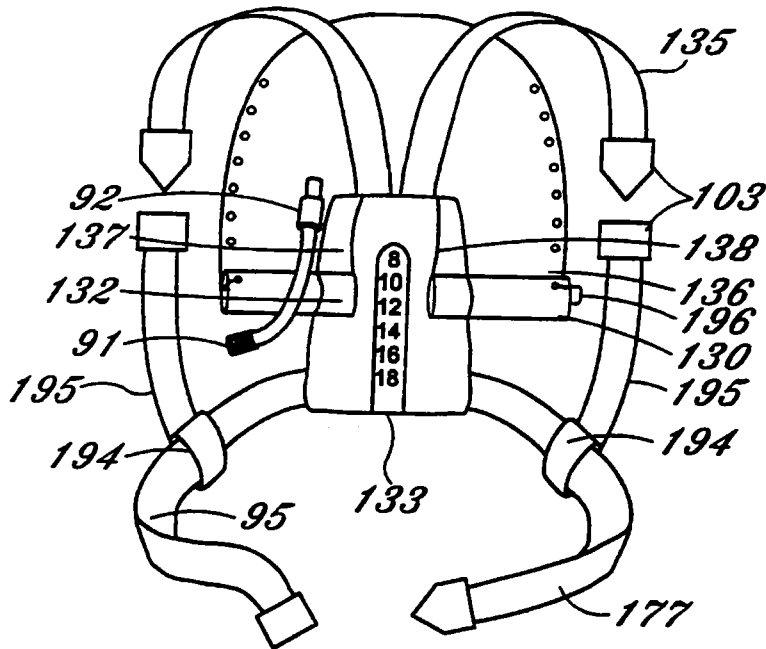

Fig. 13

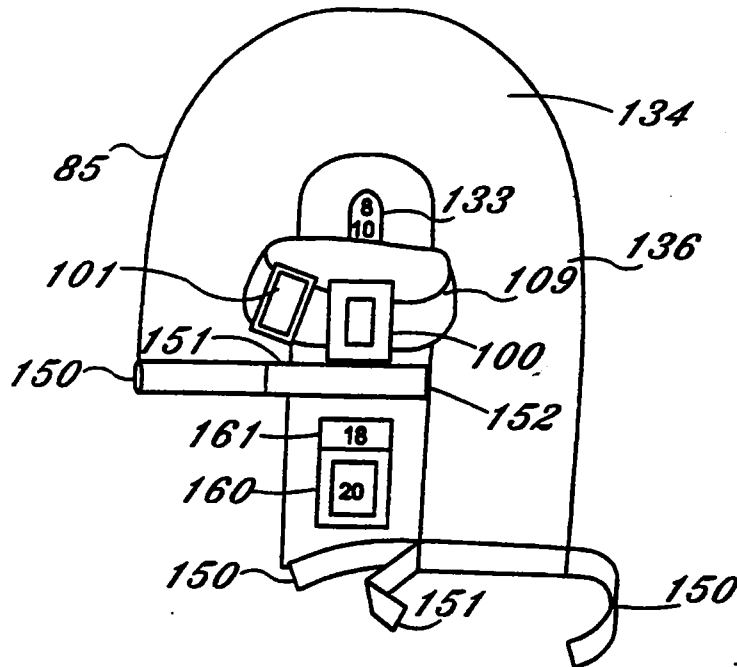

Fig. 14

U.S. Patent

May 6, 2003

Sheet 7 of 34

US 6,558,082 B1

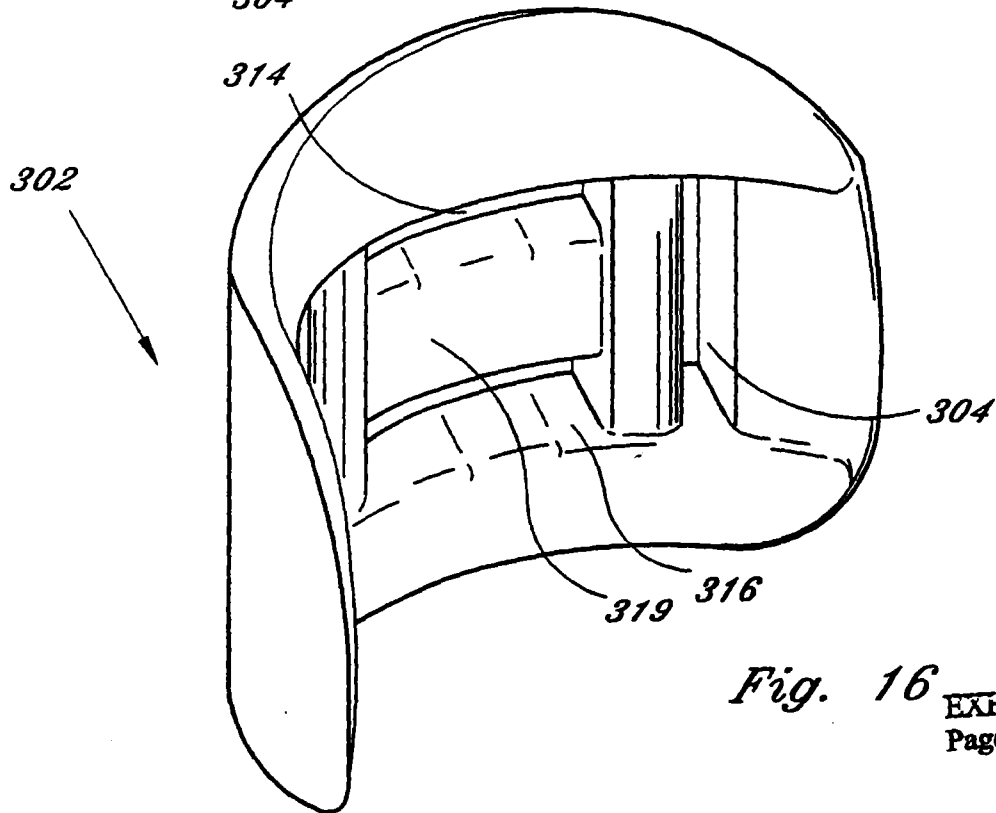
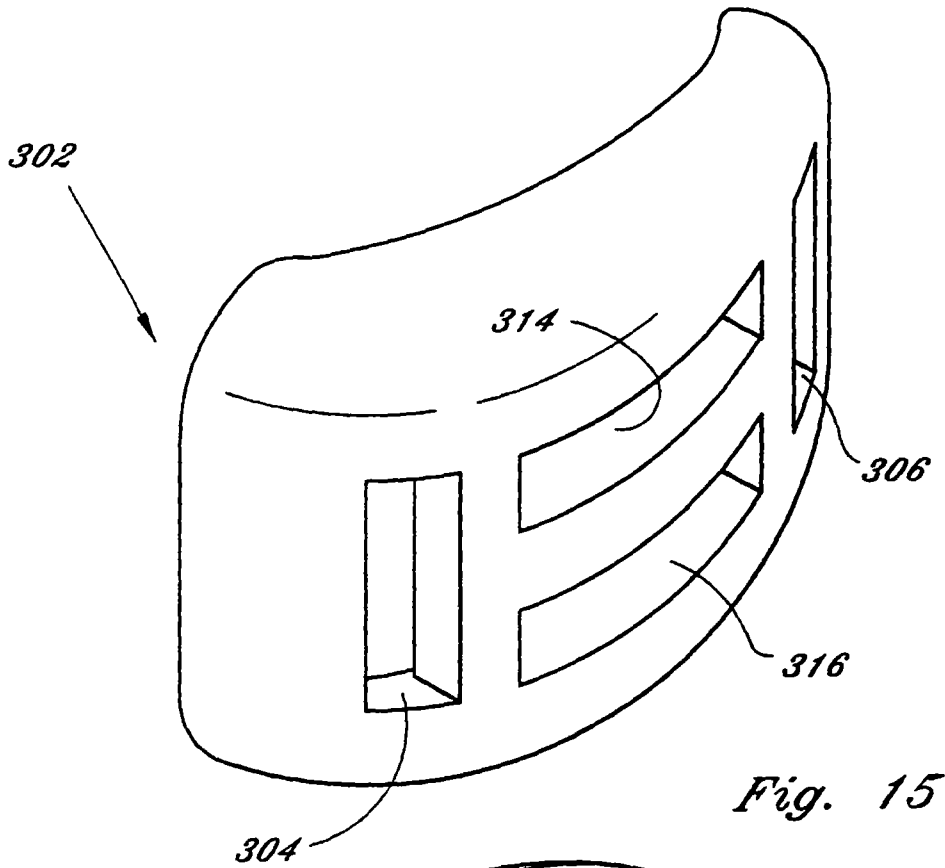

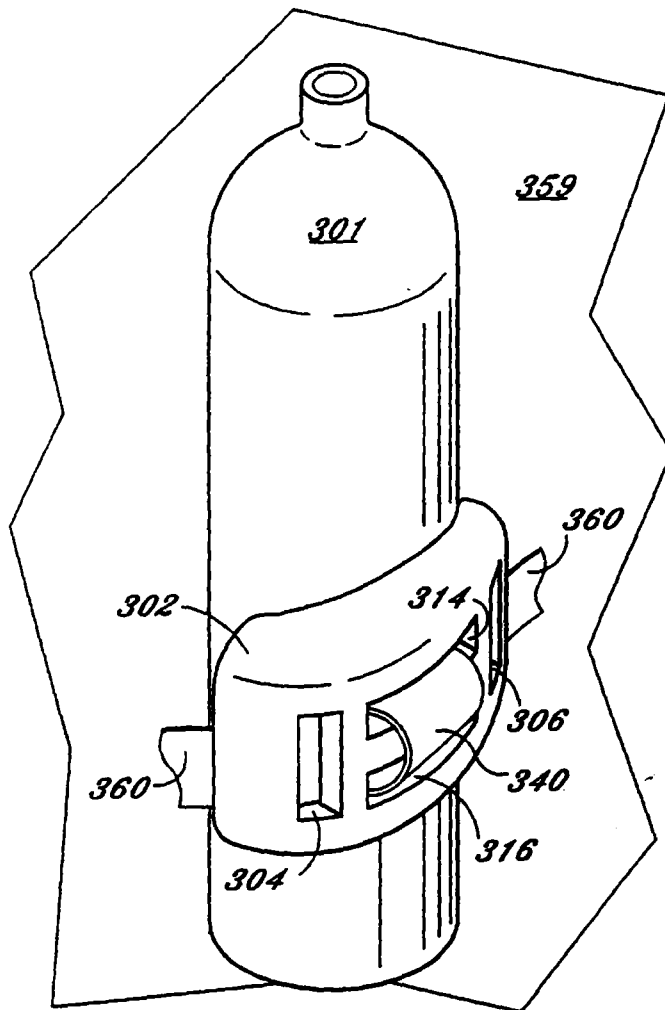
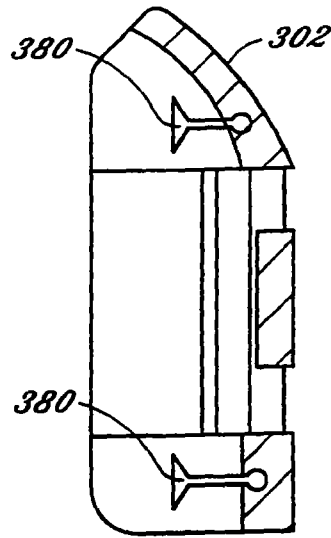
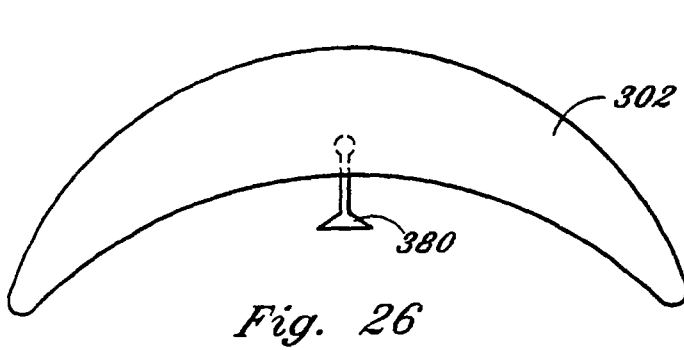

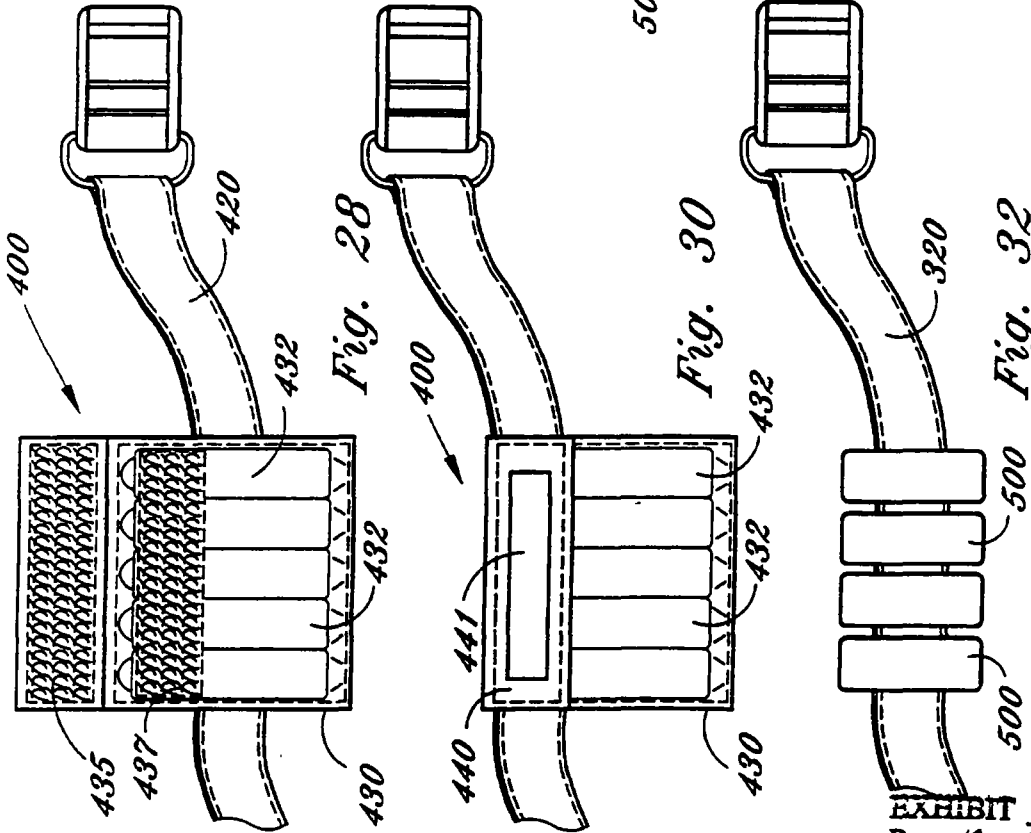
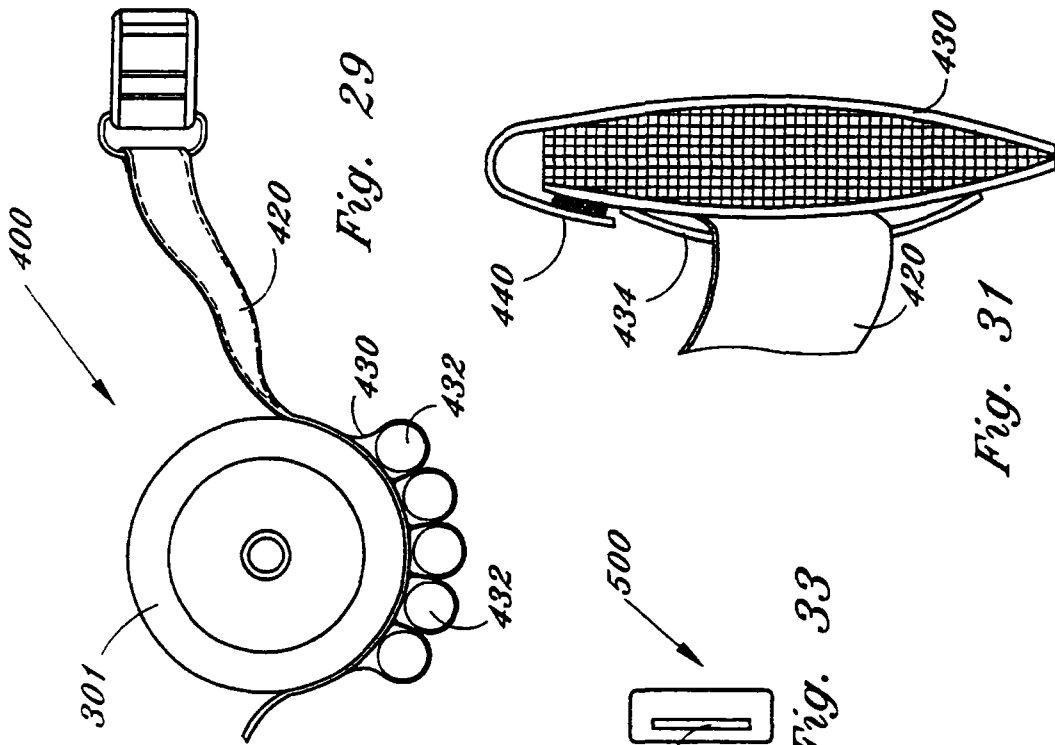

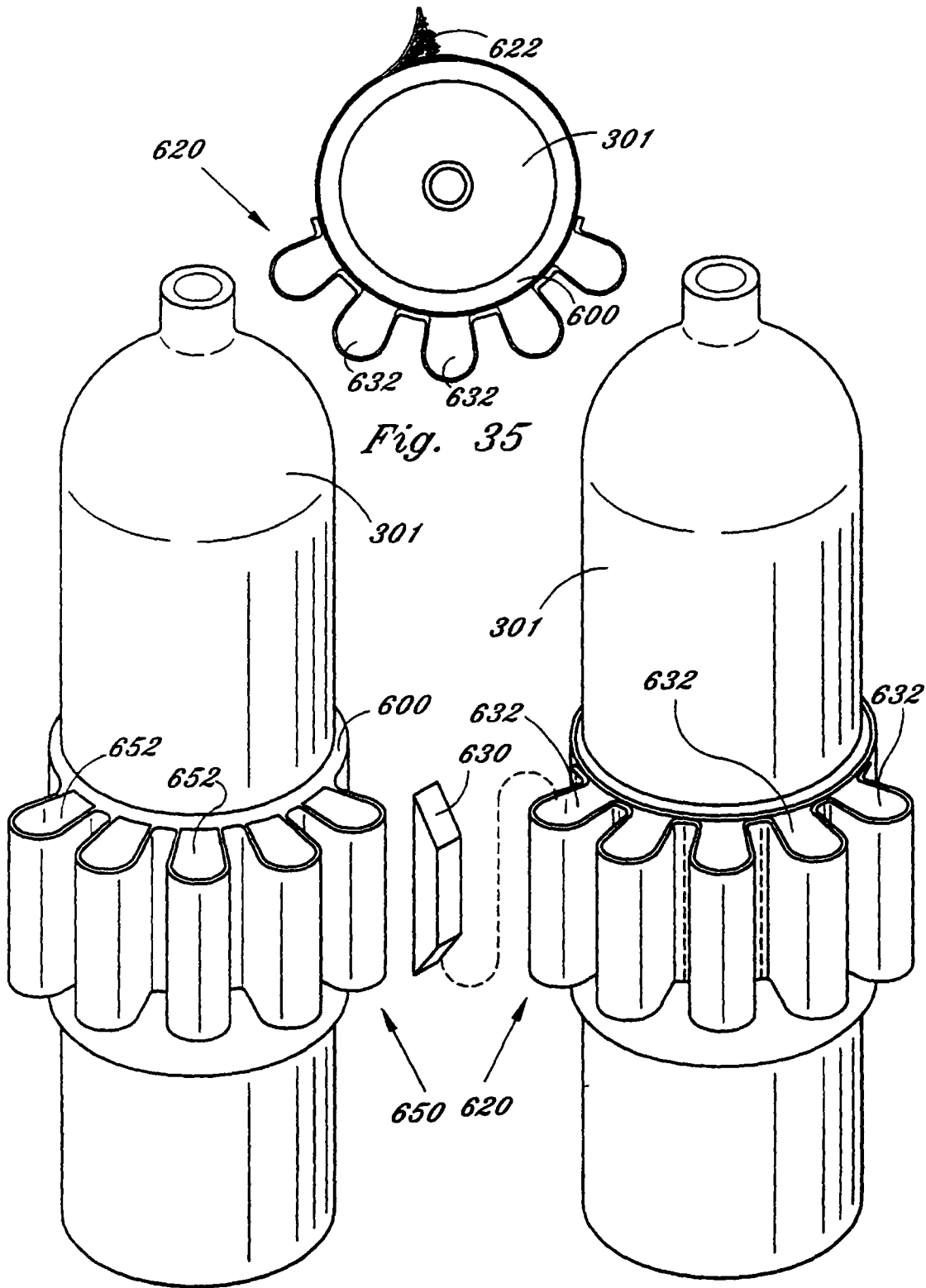
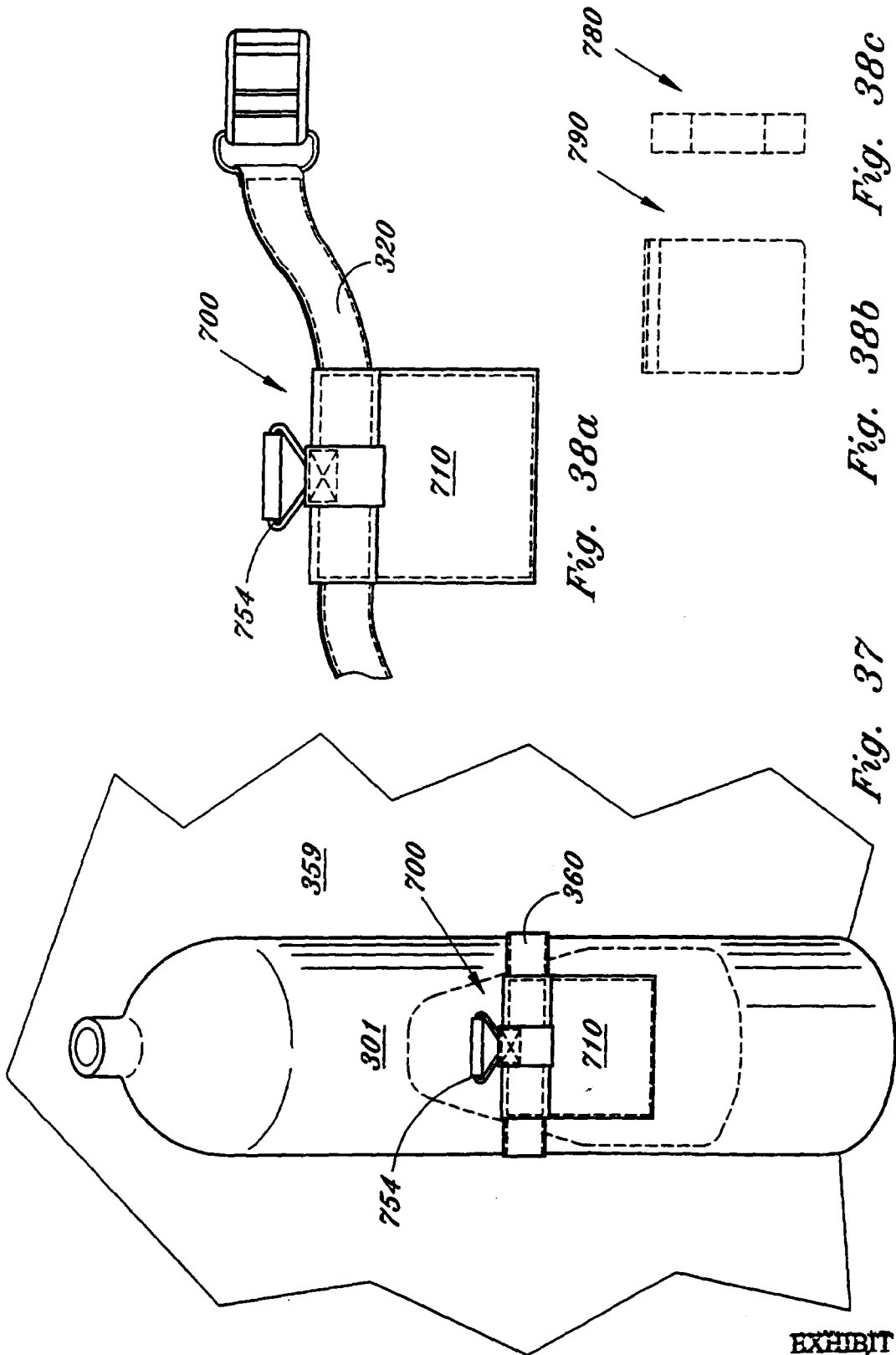

Fig. 36

Fig. 34



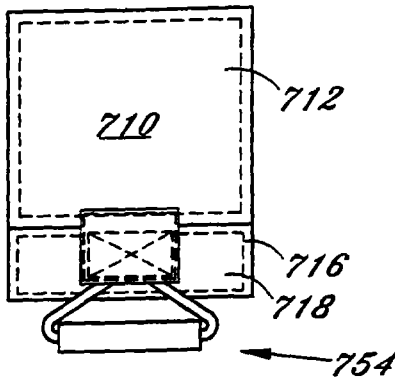

Fig. 39a

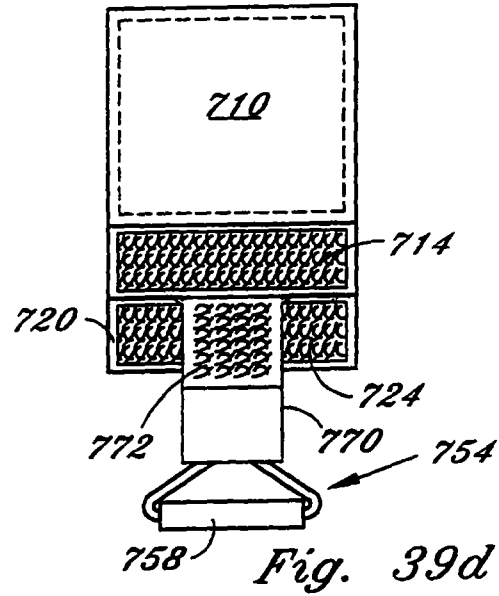

Fig. 39d

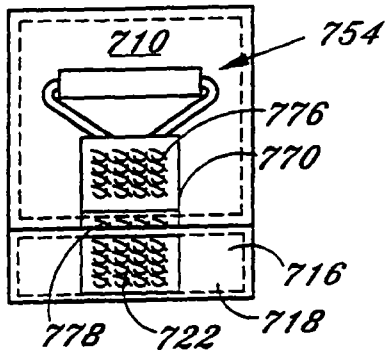

Fig. 39b

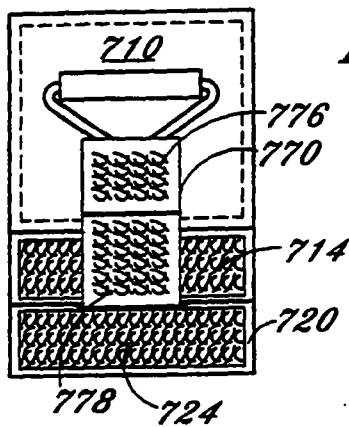
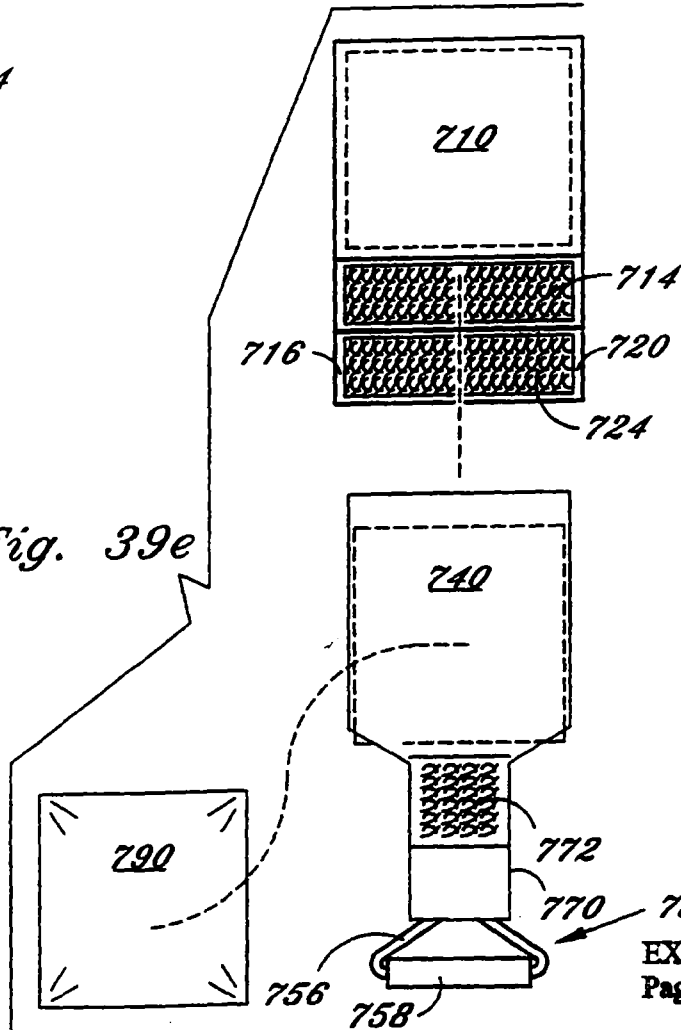

Fig. 39c

Fig. 39e



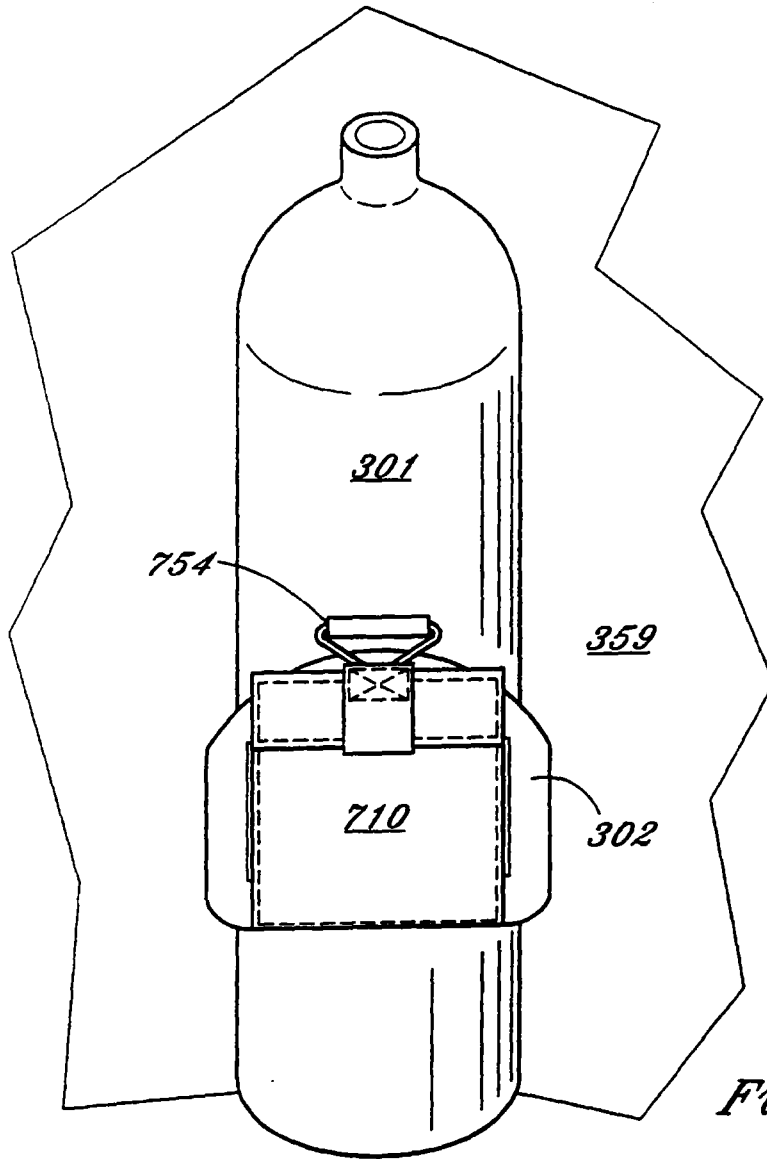
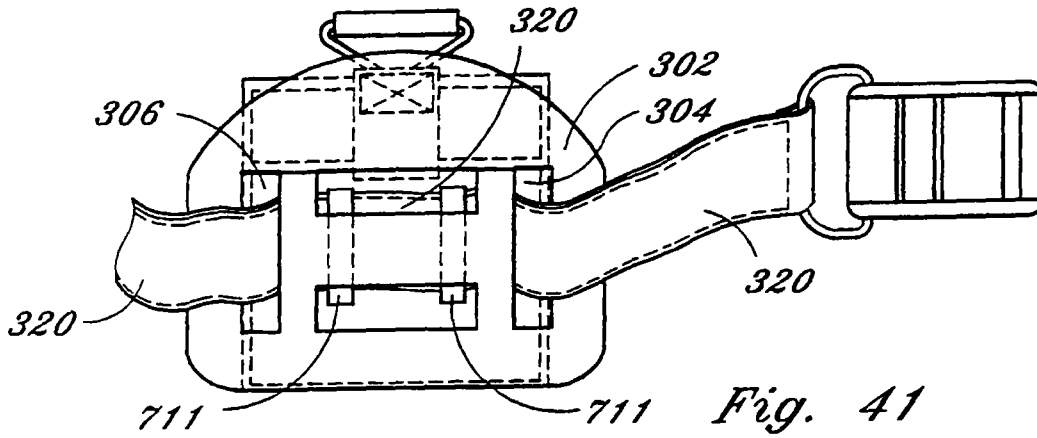

EXHIBIT c
Page 112 of 167 pages

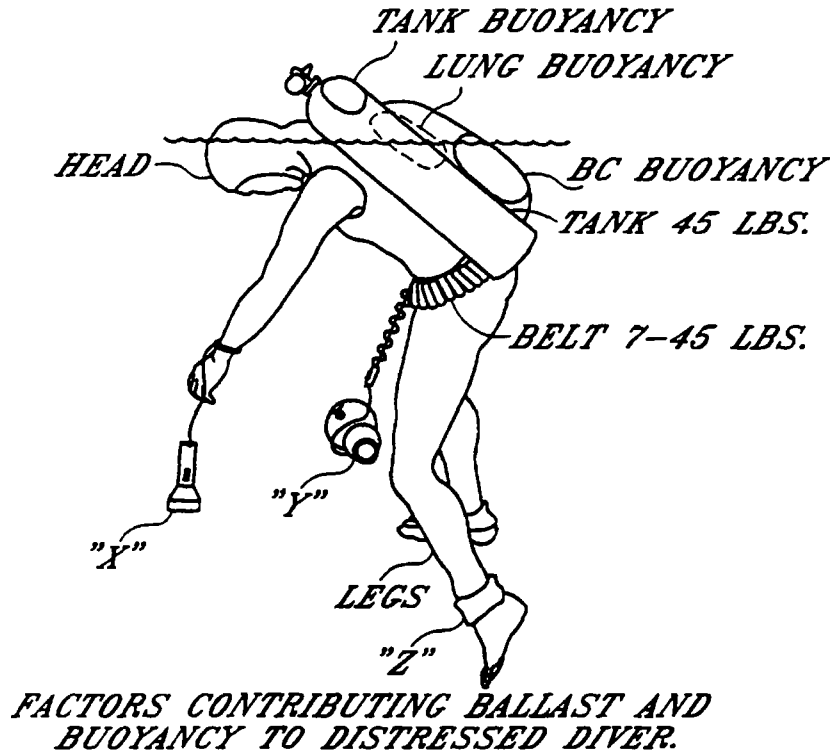

Fig. 42

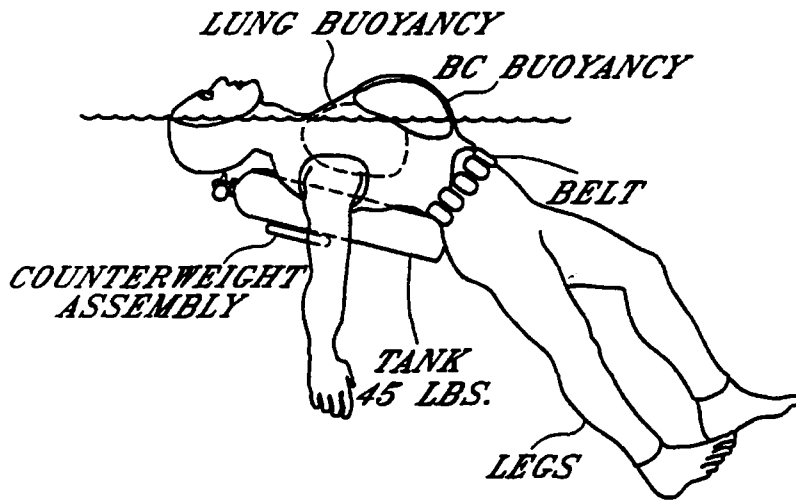
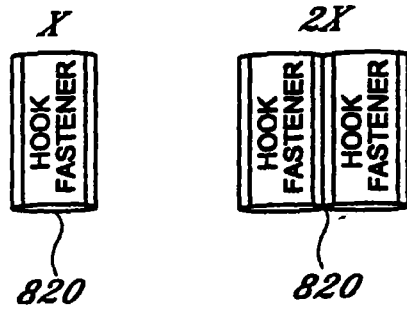
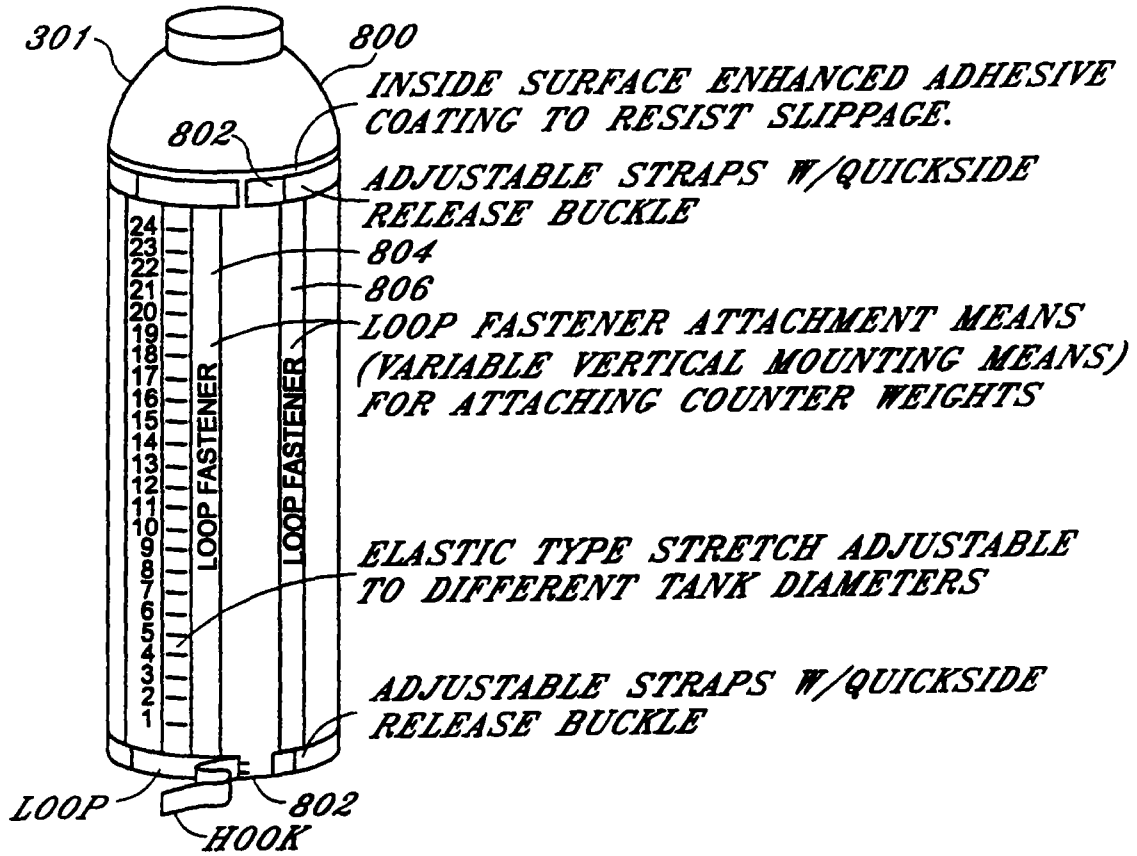

Fig. 43



VARIABLE WEIGHT SIZING W/HOOK FASTENER

Fig. 44

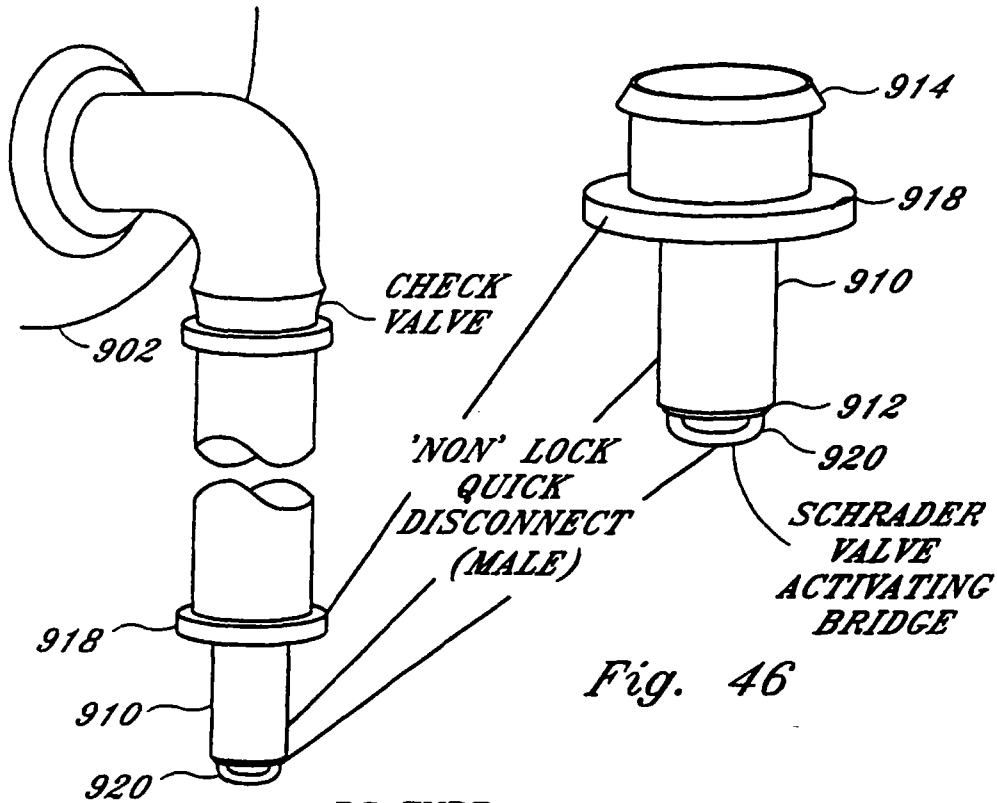

Fig. 46

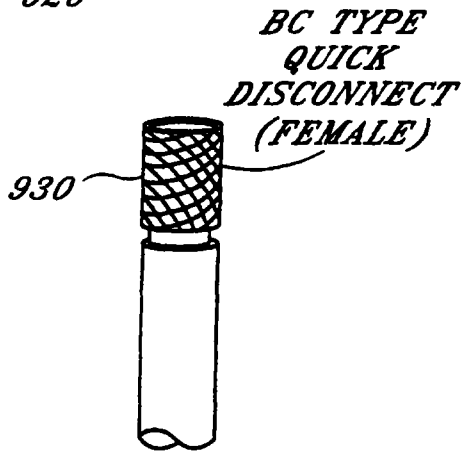

Fig. 45

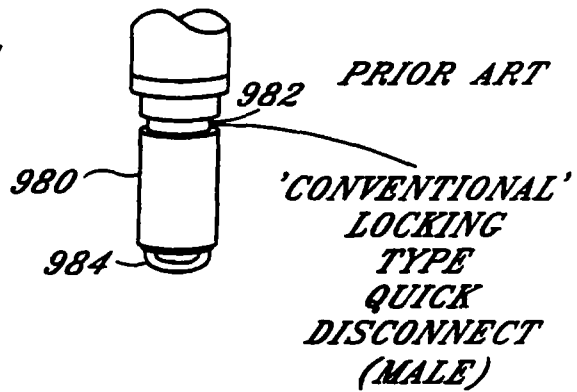

Fig. 47

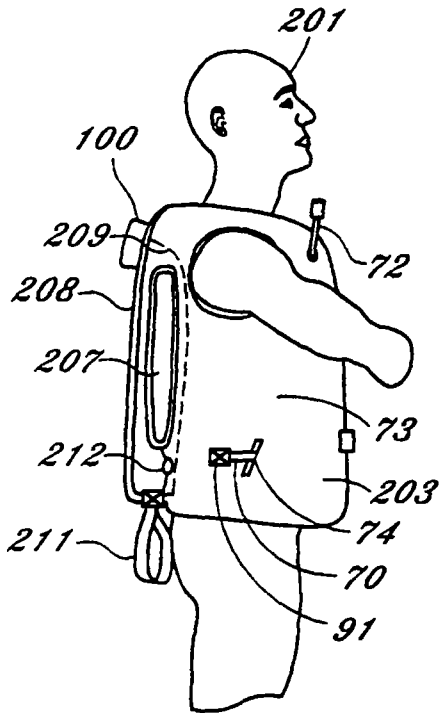

Fig. 48

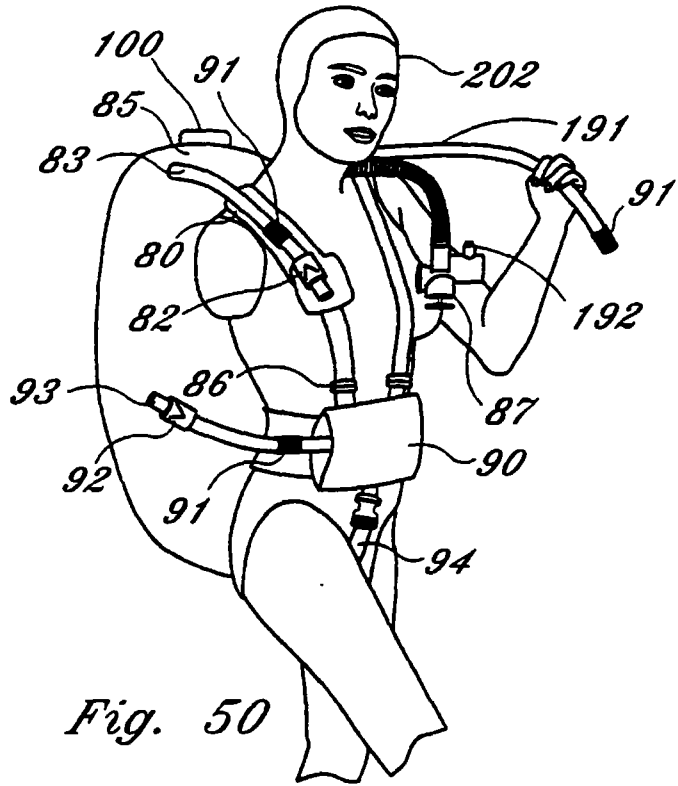

Fig. 50

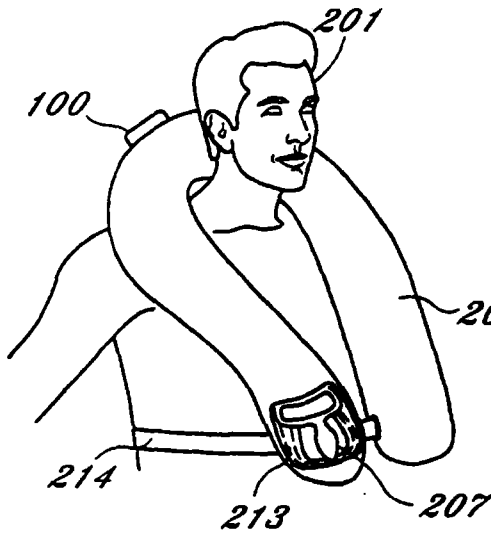

Fig. 49

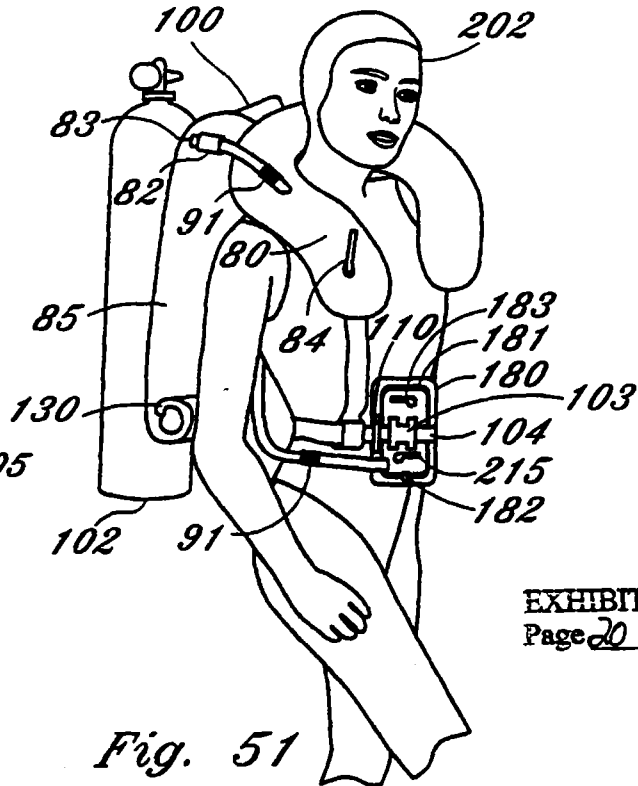
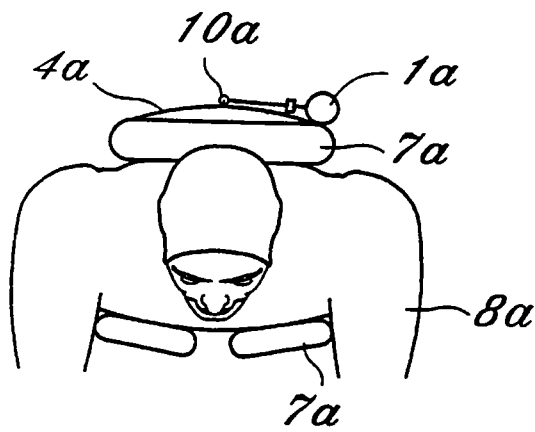
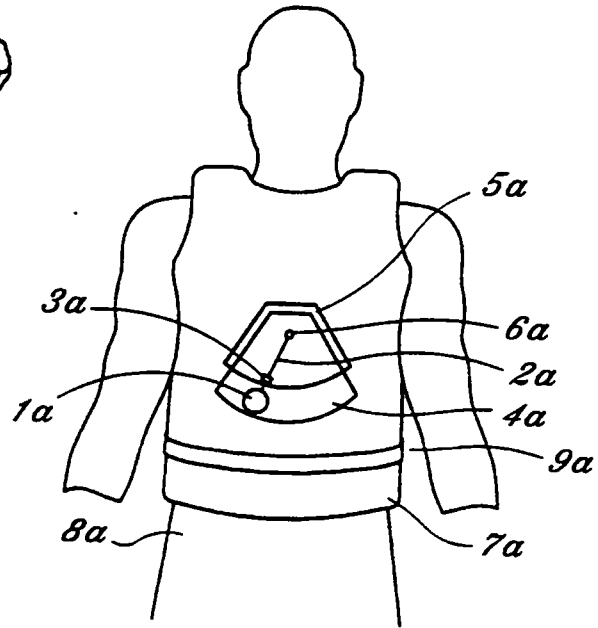
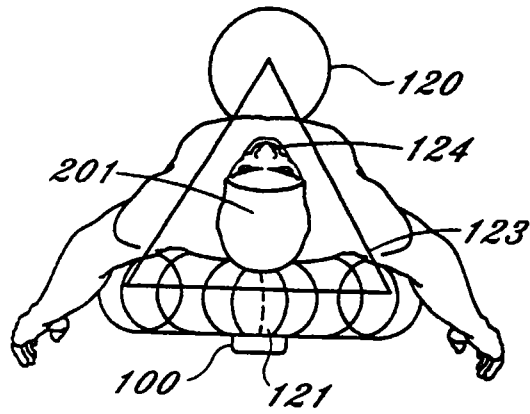

Fig. 51



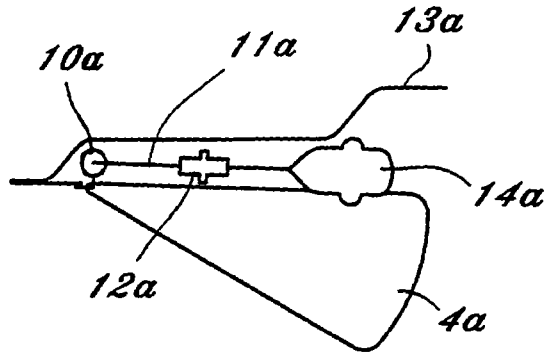

Fig. 55

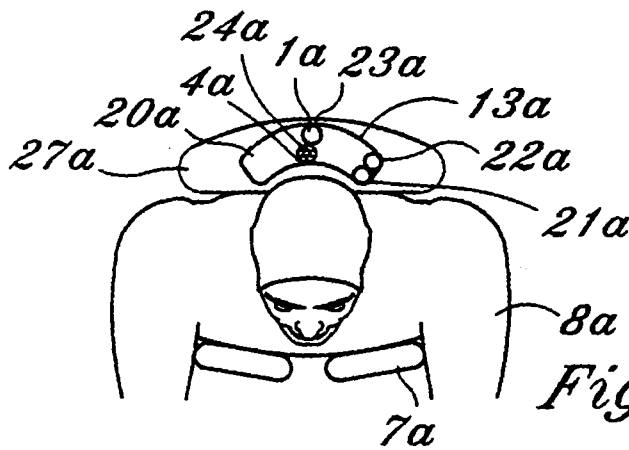

Fig. 56

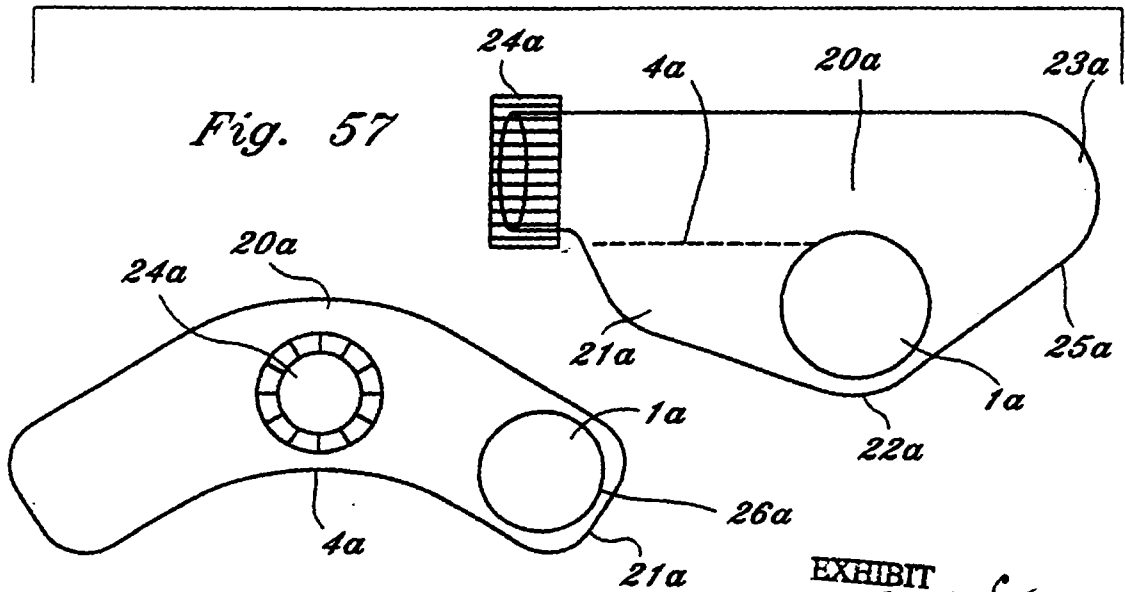

Fig. 57

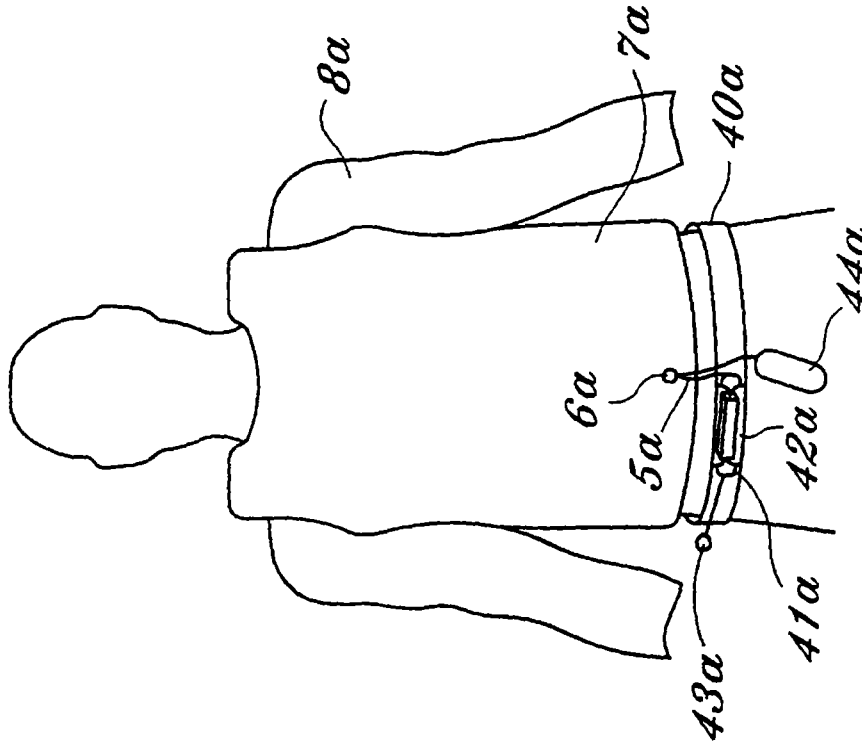

Fig. 59

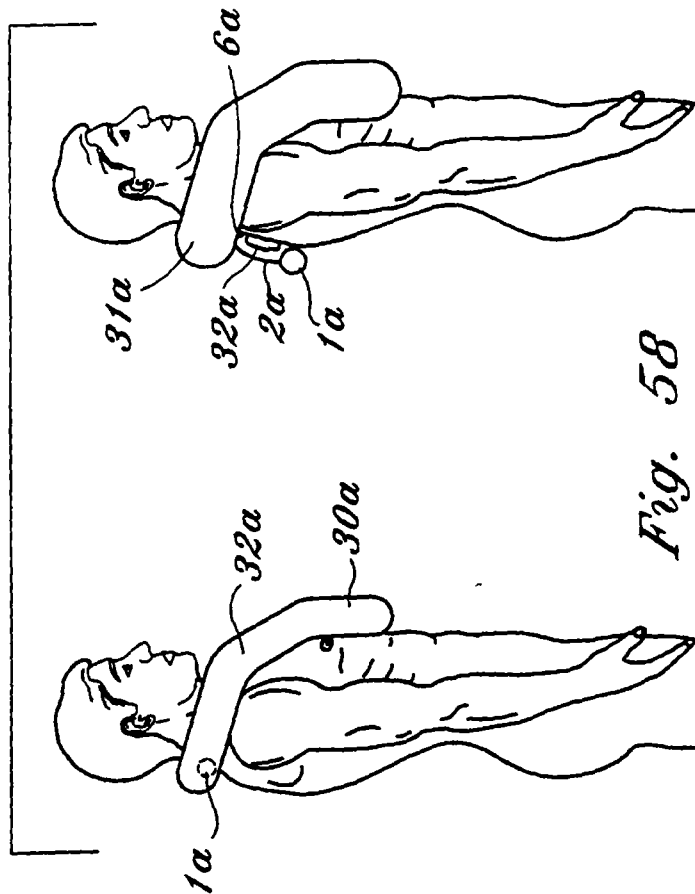

Fig. 58

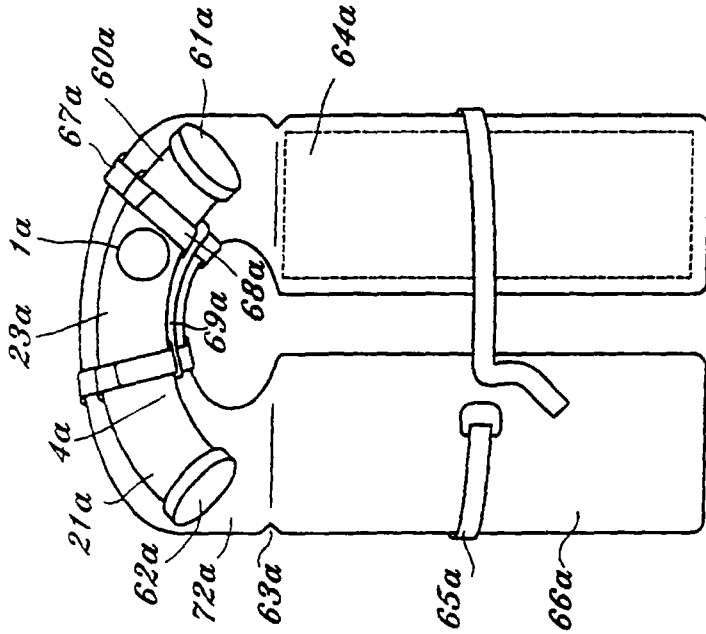

Fig. 61

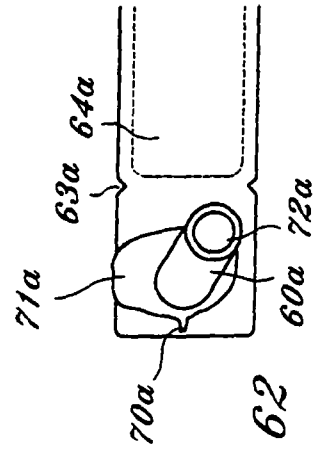

Fig. 62

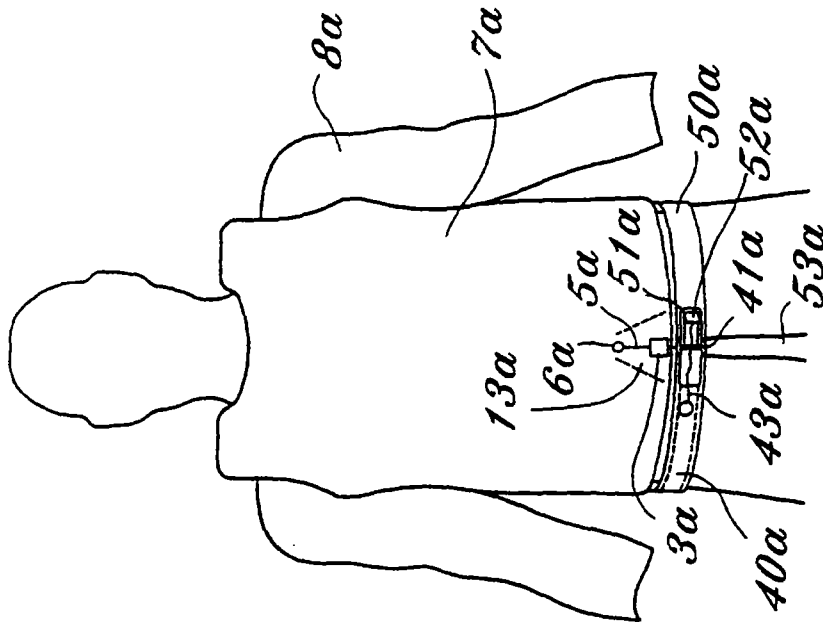

Fig. 60

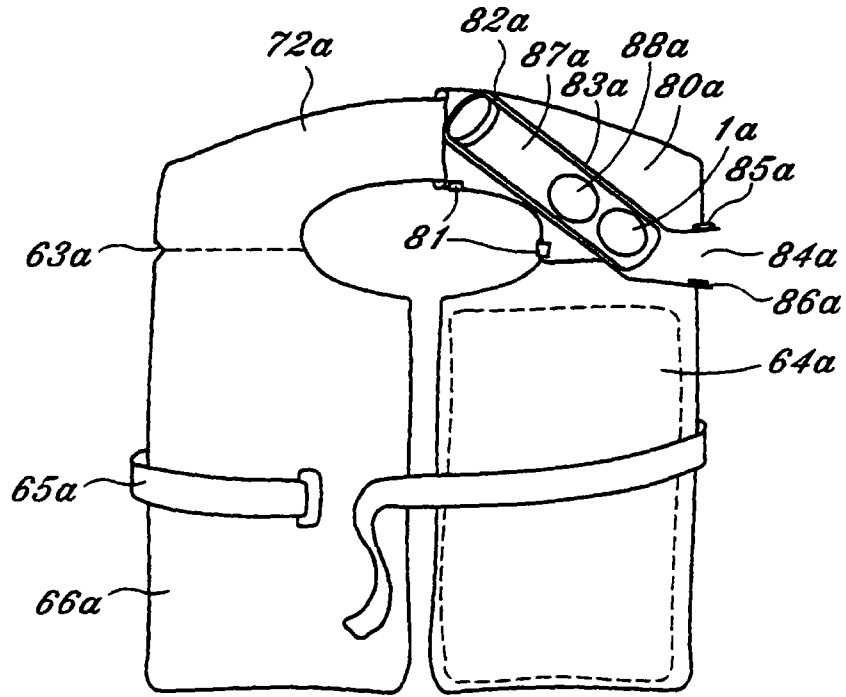

Fig. 63

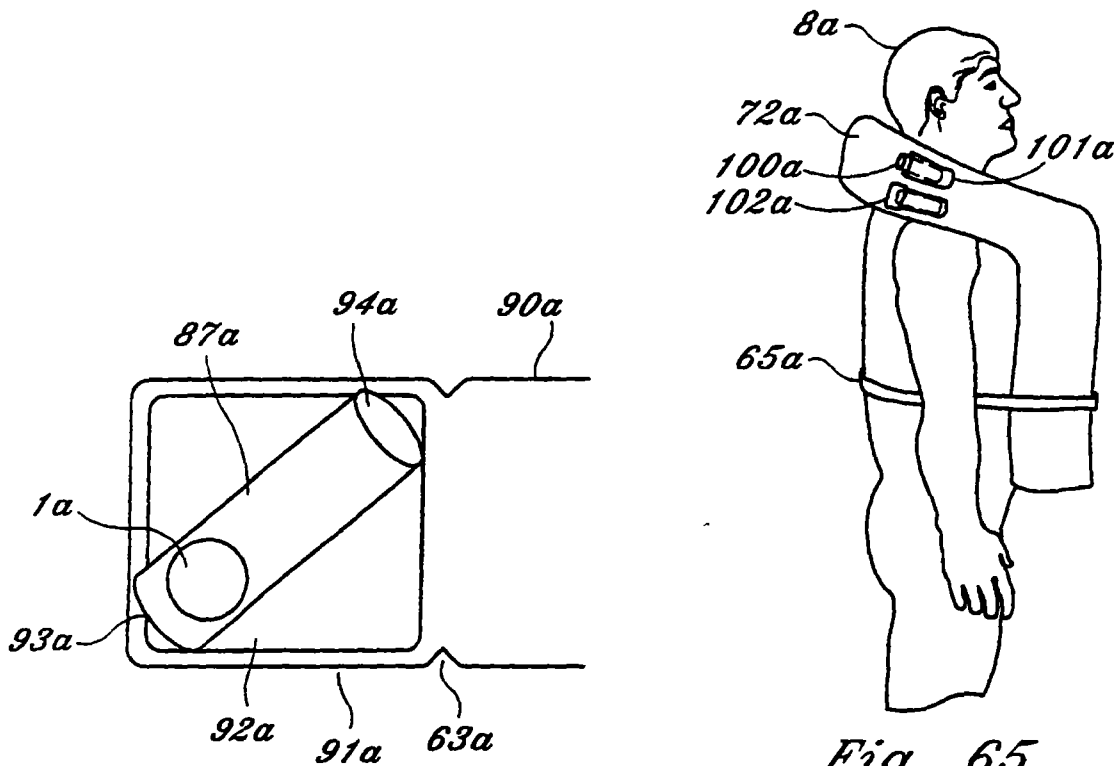

Fig. 64

Fig. 65

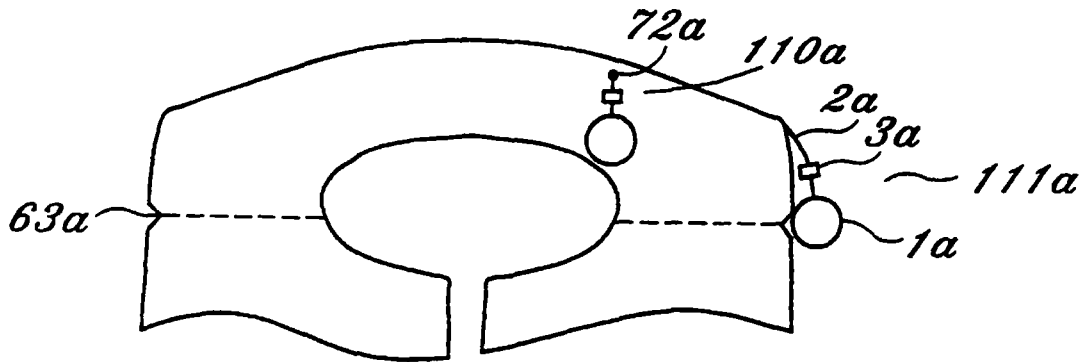

Fig. 66

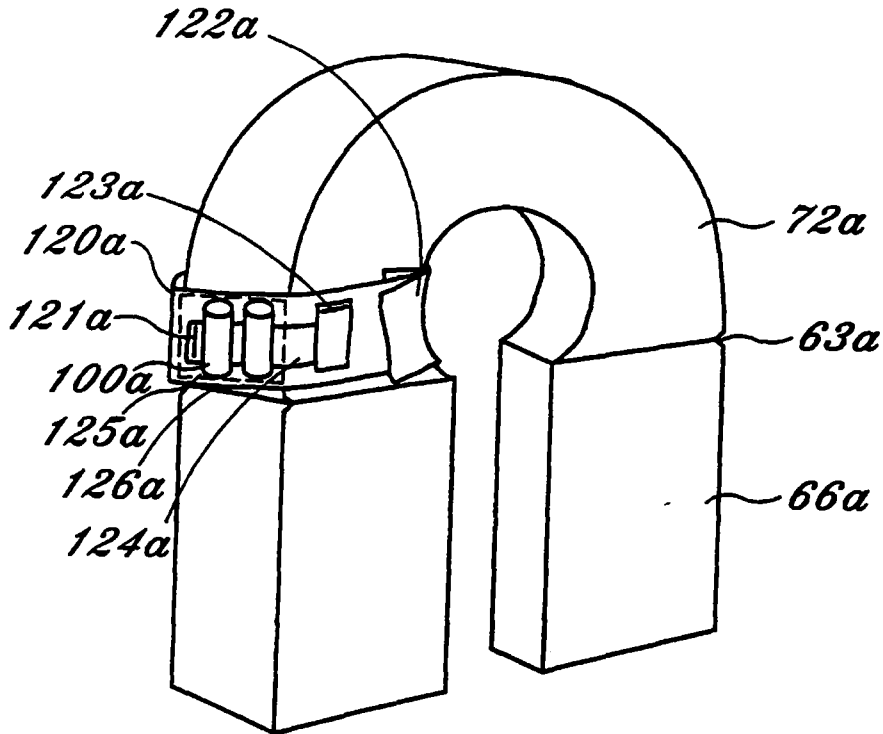

Fig. 67

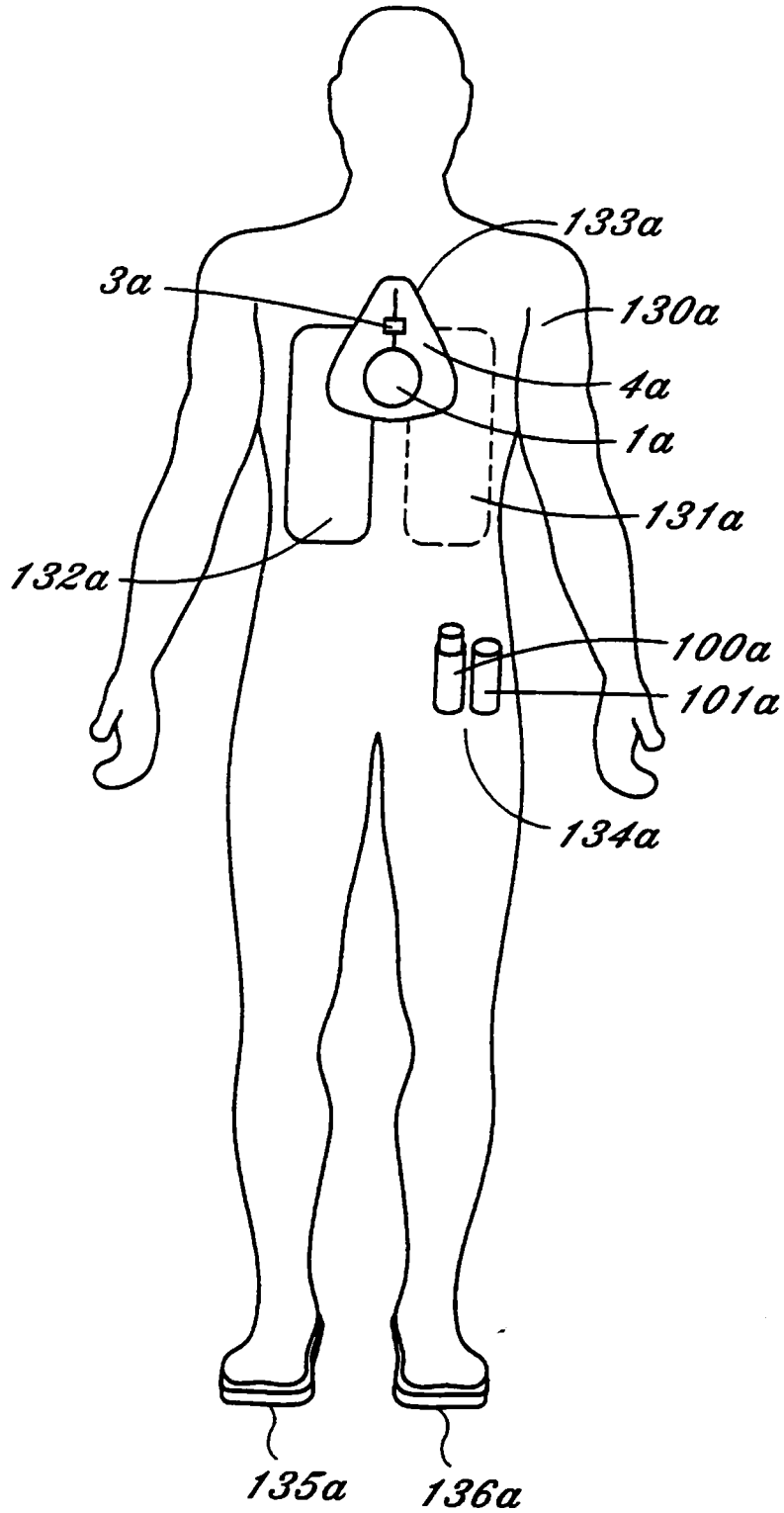

Fig. 68

EXHIBIT C
Page 21 of 61 pages

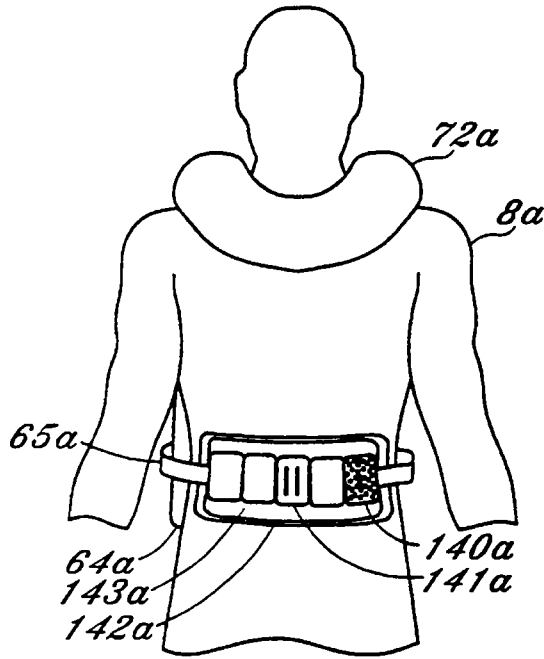

Fig. 69

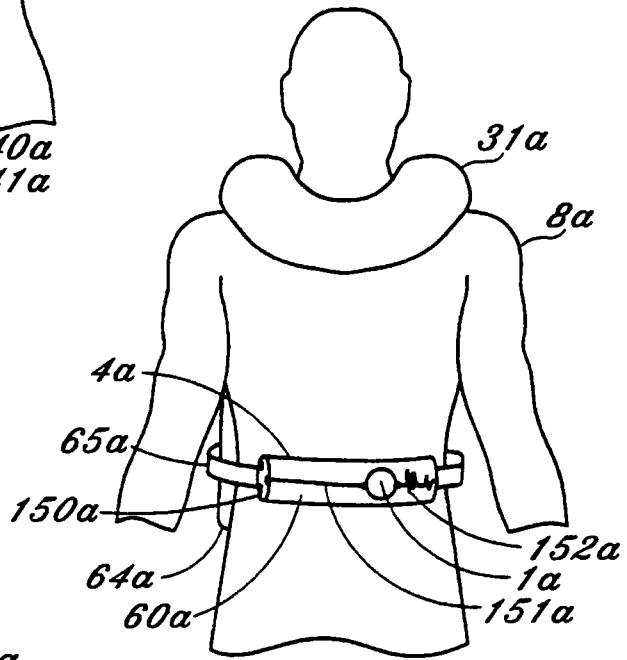

Fig. 70

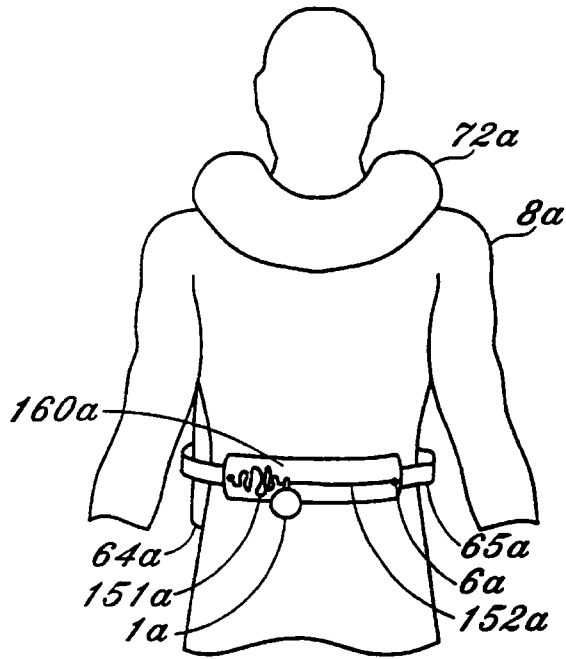

Fig. 71

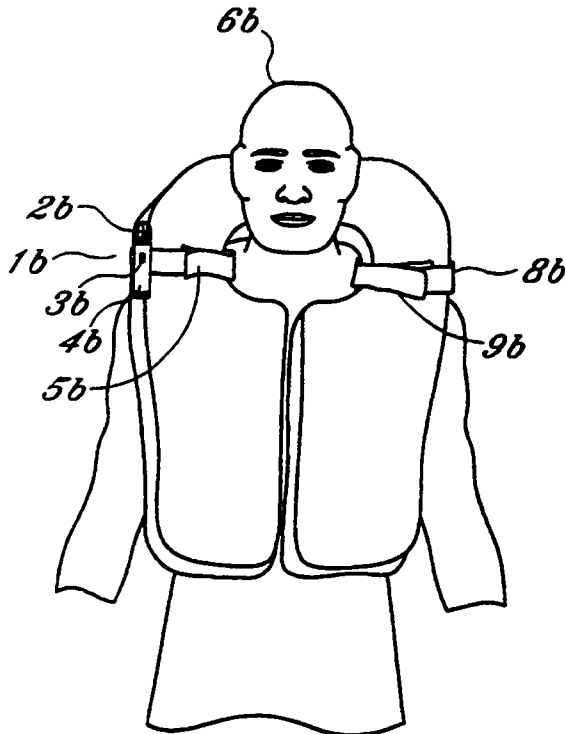

Fig. 72

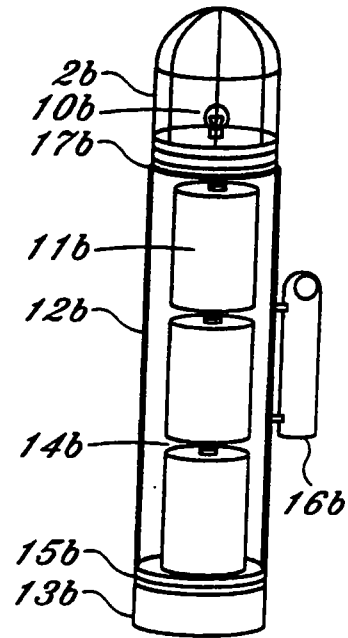

Fig. 73

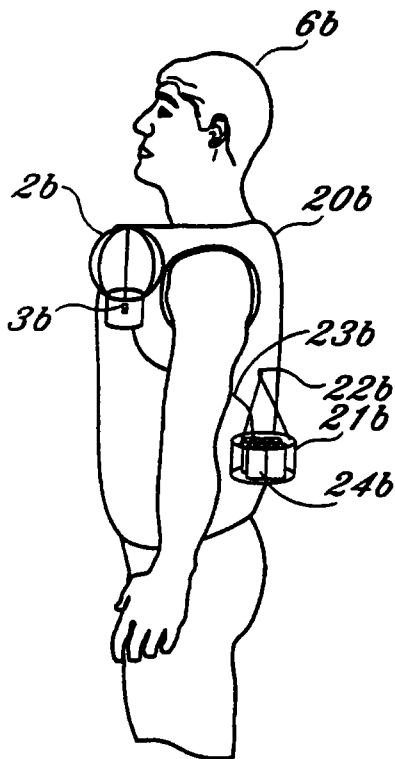

Fig. 74

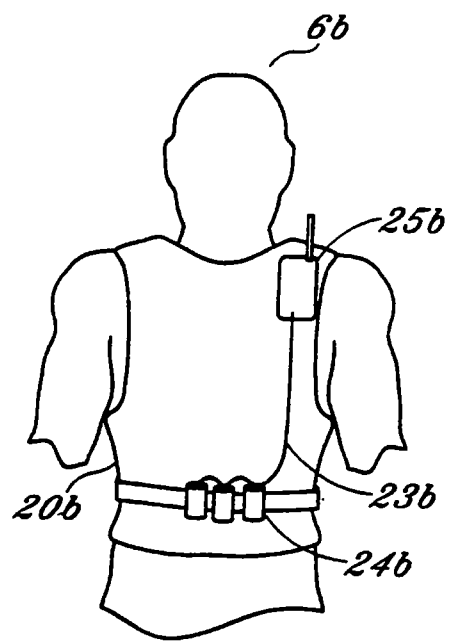

Fig. 75

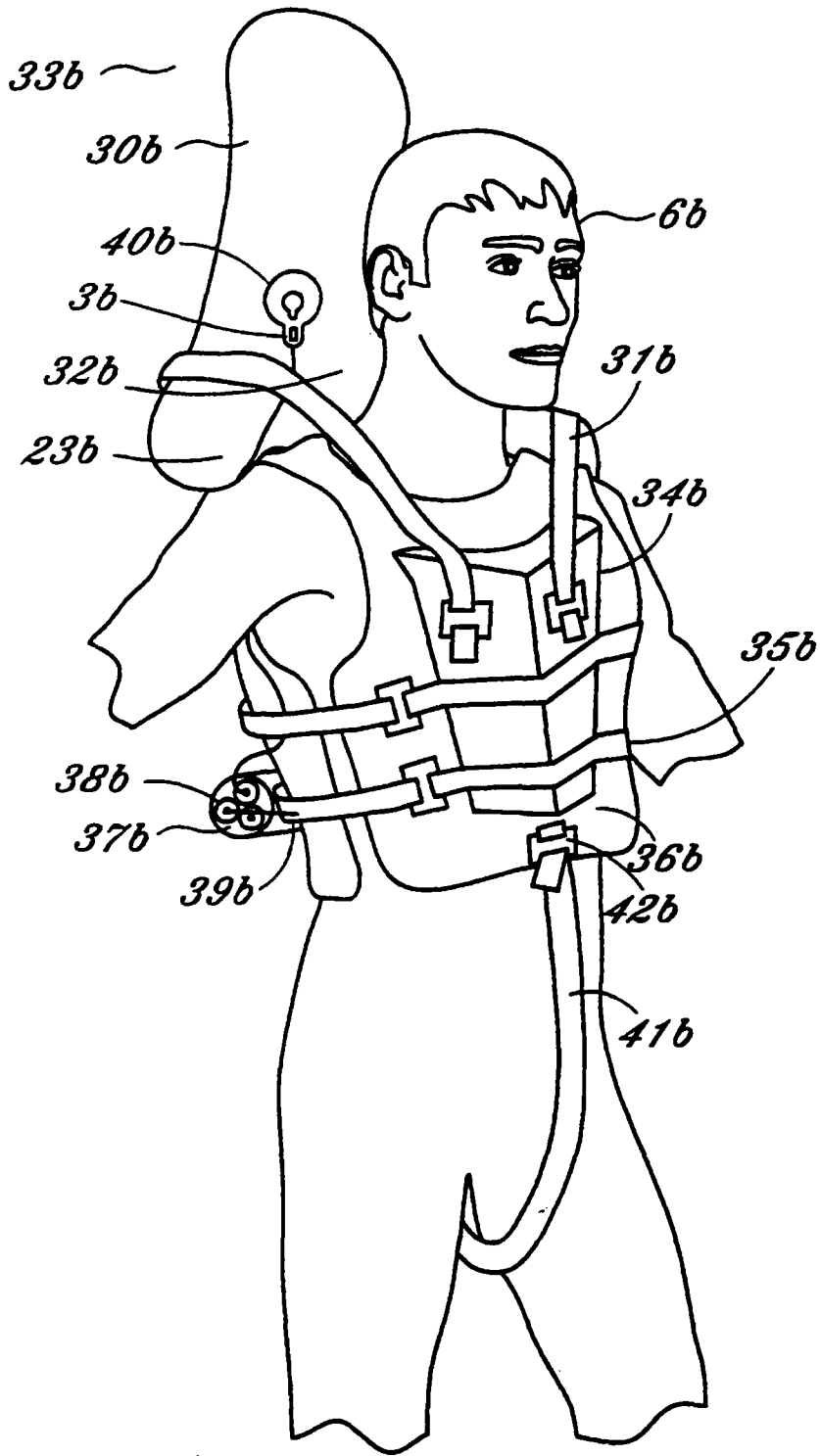

Fig. 76

EXHIBIT c
Page 20 of 1 pages

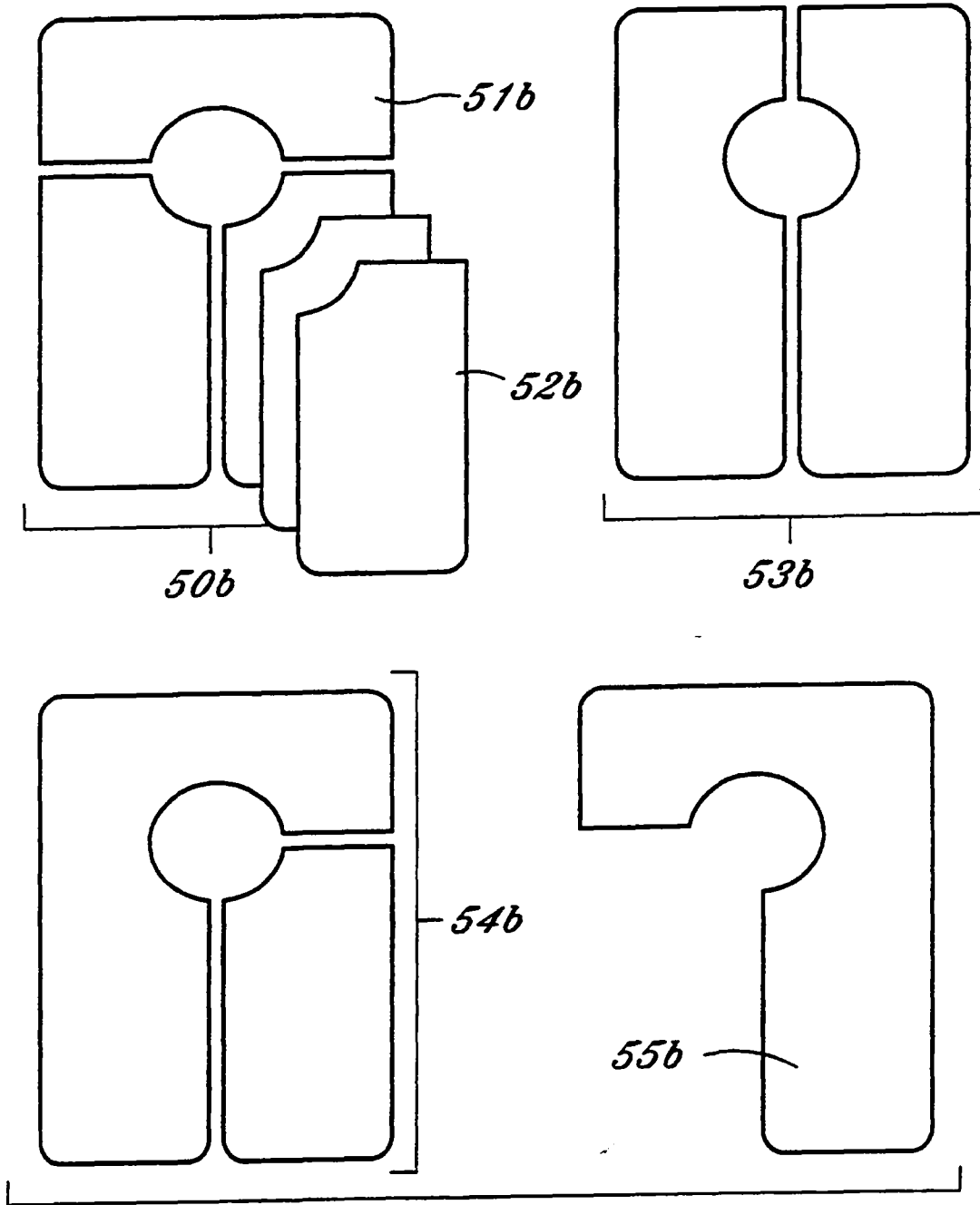

Fig. 77

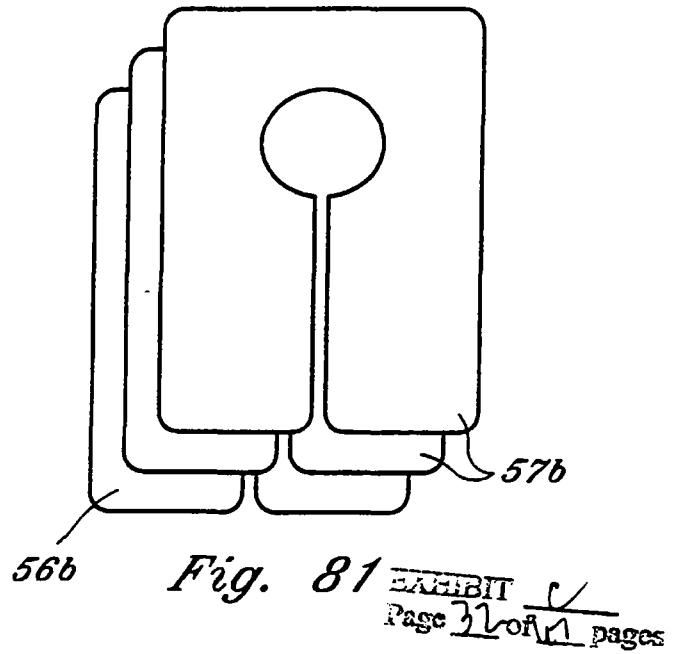
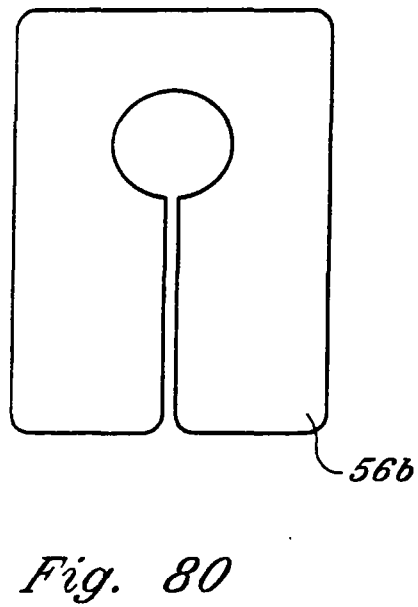
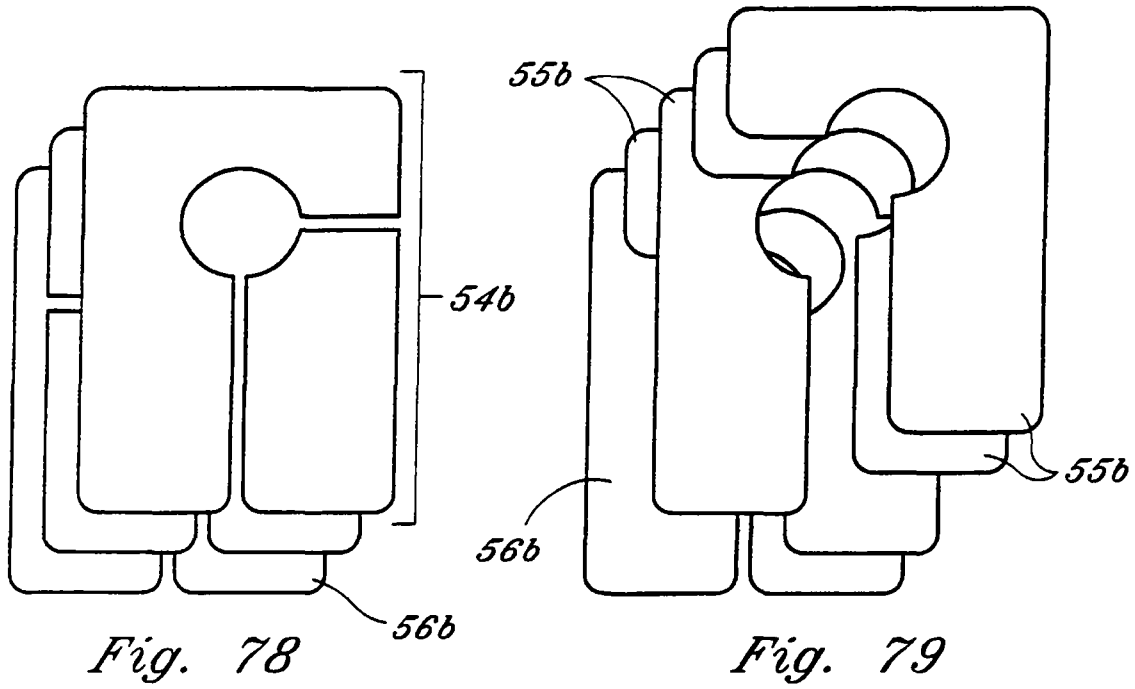

EXHIBIT ✓
Page 32 of 11 pages

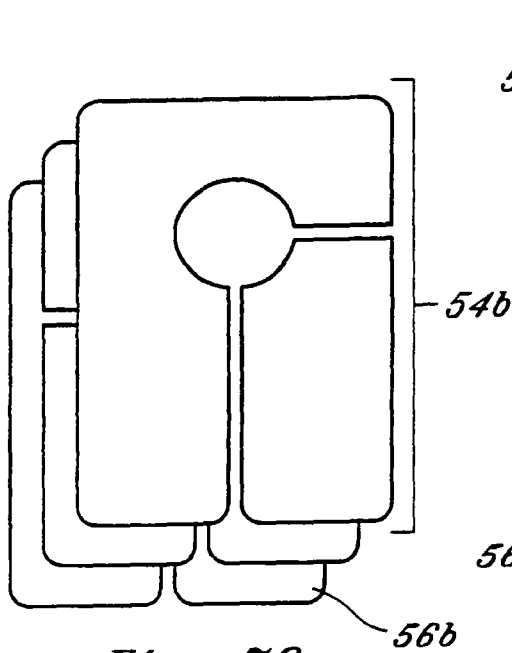

Fig. 78

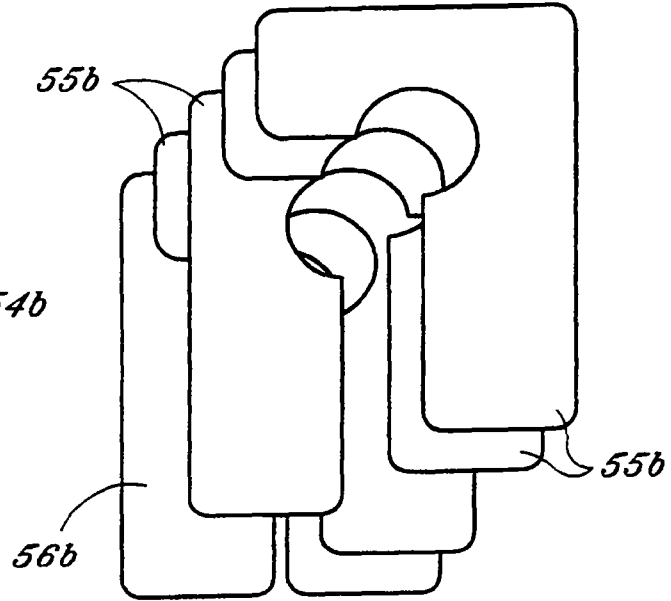

Fig. 79

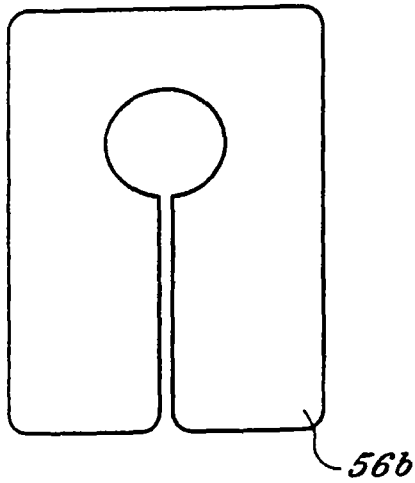

Fig. 80

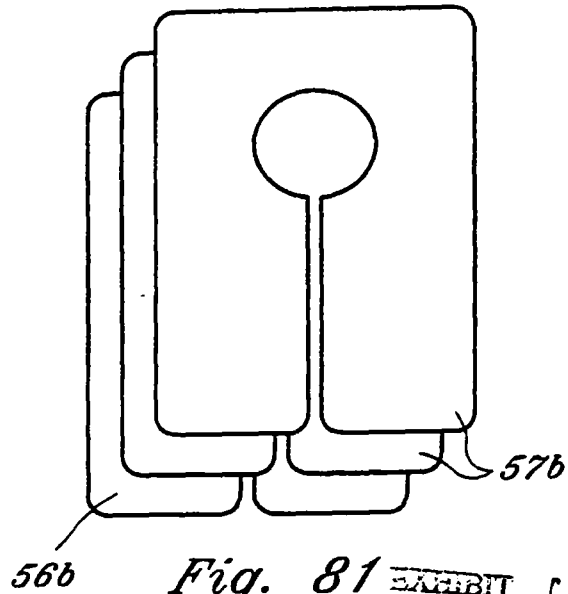

Fig. 81

EXHIBIT
Page 32 of 11 pages

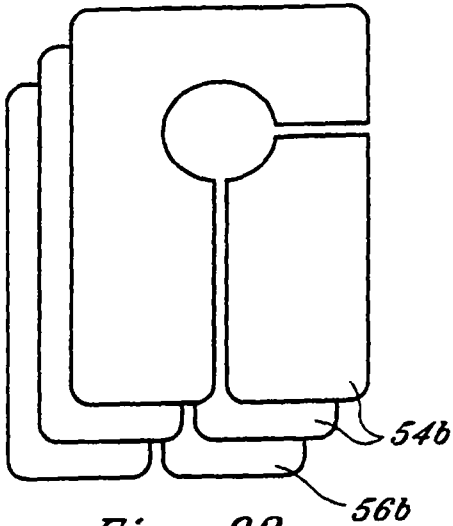

Fig. 82

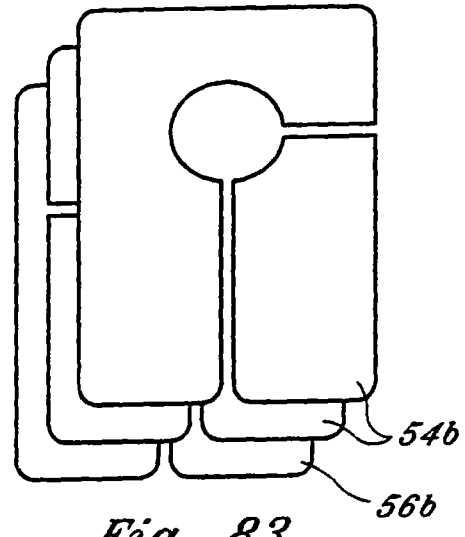

Fig. 83

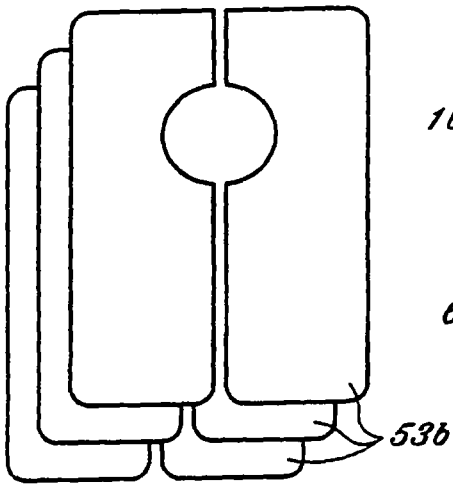

Fig. 84

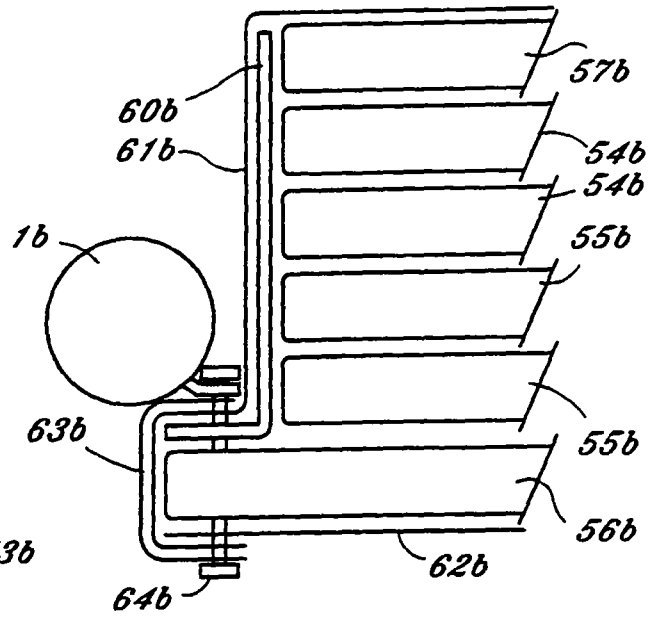

Fig. 85

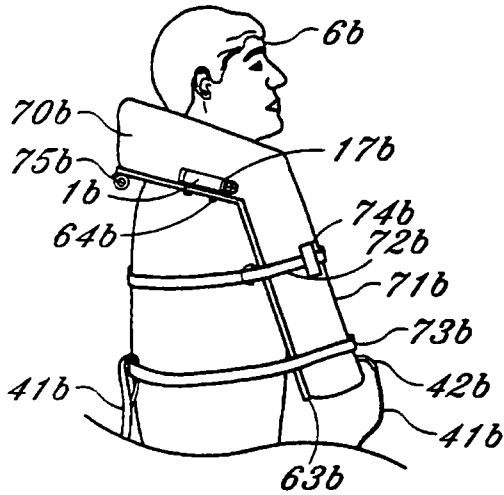

Fig. 86

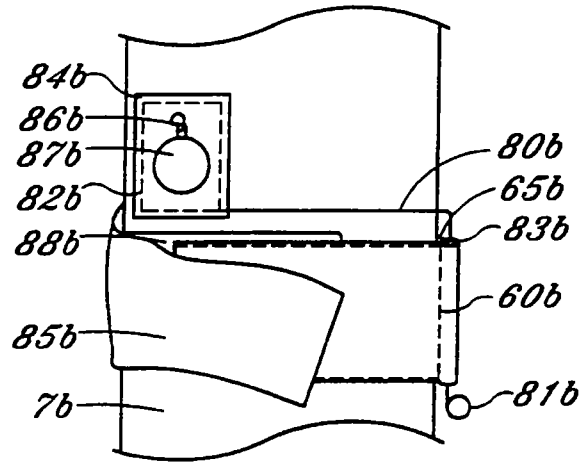

Fig. 87

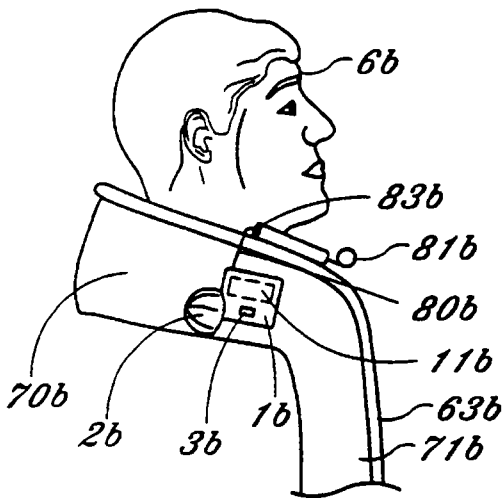

Fig. 88

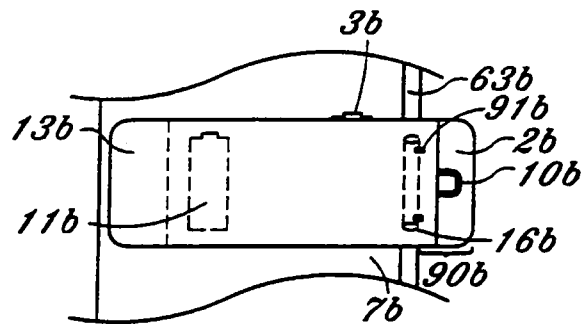

Fig. 89

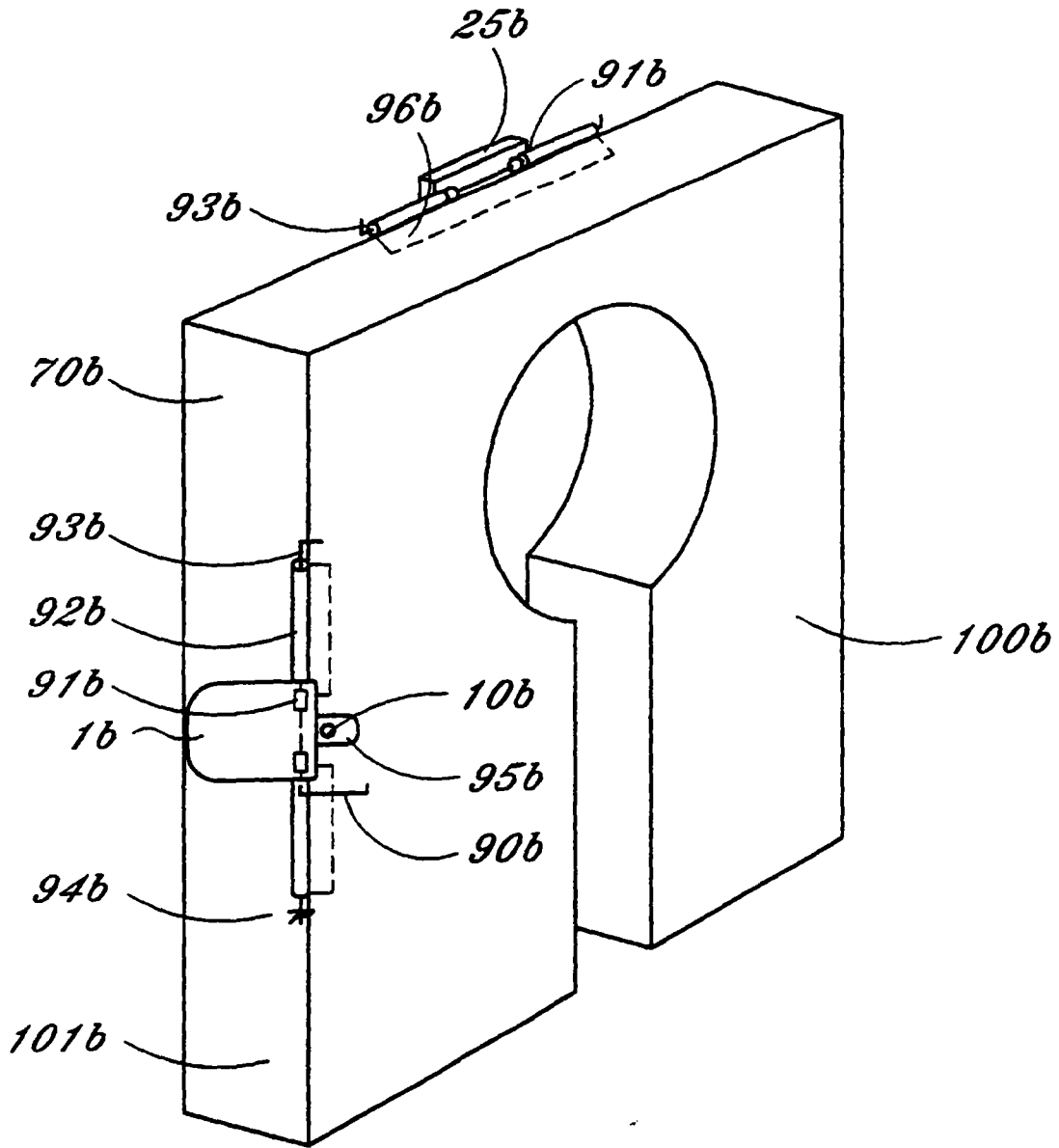

Fig. 90

COMBINED BALLAST AND SIGNALLING DEVICE FOR A PERSONAL FLOTATION DEVICE

This application is a continuation-in-part of U.S. Ser. No. 09/618,333, filed Jul. 18, 2000, which is a continuation-in-part of U.S. Application Ser. No. 09/255,892, filed Jan. 4, 1999, which is a continuation of U.S. patent application Ser. No. 08/645,206 filed May 13, 1996, now U.S. Pat. No. 5,855,454.

BACKGROUND OF THE INVENTION

1. Field of the Invention

The invention relates generally to personal flotation devices and particularly to a personal flotation device incorporating a ballast member.

2. Description of the Prior Art

Heretofore, accidental immersion often resulted in death by two causes, aspiration leading to asphyxiation or hypothermia. A life saving system, to be viable for more than a few minutes, must successfully address both of these issues. Current life vests supply the requisite amount of buoyancy to return the victim to the surface, but often require a conscious victim's involvement to keep the airway clear. While it is common practice, as well as legally mandated, that all civilian, commercial, and non-civilian vessels carry Coast Guard approved life vests, many current water safety products provide only a limited portion of the safety they are capable of providing. They do provide for positive buoyancy during the shock of the initial entry into the water, but by incorporation of the concepts disclosed herein are capable of providing significantly improved airway protection after the initial insult with significantly increased reliability of airway protection and less bulk, cost and, consequently, more compliance.

By force of habit, life vests are currently designed after clothing and as such they open in the middle of the chest, producing a point of reduced buoyancy where it is least acceptable. The division of the forward chamber into two halves produces two side chambers which are each capable of generating righting moments in the water. When a righting moment is created on the body of an exhausted or unconscious individual, they can be stabilized in a face down or side down position. If the left or right side is out of the water, concurrent loss of muscle tone in the neck allows the face, nose, and mouth to be positioned underwater. Thus, current constructions of many life vest are really only adequate for conscious, alert, and active victims because they require participation, constant monitoring and adjustment by the user to keep the face and airway out of the water.

On sudden entry into the water, water on face actuates the Dive Reflex, which is a rapid uncontrollable inhalation. This reflex often results in aspirating water with its consequent choking and coughing. This distress further complicates the victim's ability to right themselves and assist in their own rescue. It is often the case that the sailor who is knocked overboard by the boom of the sail or is swept overboard by a wave, can suffer a temporary loss of consciousness. During this initial interval it is important that their life vest not only buoy them to the surface, but that it also obtain and maintain the victim's face and airway out of the water until consciousness is regained.

The only life vest that is of any value is the life vest that is worn. Compliance can not be ignored as an important criteria in the design and manufacture of any safety product. The actual use of safety vests has begun to move forward by

the hybrid personal flotation devices. The HPFD is a combination of a certain amount of inherently buoyant material along with an additional amount of inflatable buoyancy. Because of the reduced amount of bulk and therefore increased convenience associated with the hpfd, their acceptance is growing. U.S. Pat. No. 4,681,552 issued Jul. 21, 1987 to William Courtney, addresses the value of hybrid personal flotation devices. Like many vest style safety products and in particular all buoyancy compensators, the BC vest described in U.S. Pat. No. 4,681,552, when both chambers are inflated in the configuration disclosed in FIG. 1, would stabilize the user on their side, placing their airway underwater if the user was unable to hold their head up.

The vest that is constructed entirely from inflatable chambers is much more comfortable, convenient and therefore is frequently worn by itself and is now approved by the United States Coast Guard. The purely inflatable product such as the inflatable sailing harness, wind breaker, safety device, because of its compactness, is often the actual product worn by the victim. Many purely inflatable safety products attempt to compensate for the lack of inherent buoyancy by generating large amounts of lift. The use of excessive lift often results in the use of air under the arms where it creates the side up righting moment that can jeopardize the airway, a design defect addressed by the instant invention.

The airlines, because of their insoluble stowage problems are allowed the use of a purely inflatable device that has redundant chambers to guard against the failure problems inherent in single chamber safety devices. The scuba diver also wears a purely inflatable device known as a buoyancy compensator or "BC," which looks like a traditional life vest but because it lacks at least reliability is not called such. The sailor is known to use inflatable wind breakers. All these devices, as well as many not described here, that are meant to provide surface flotation to individuals in the water, would be markedly improved by incorporation of the concepts described herein. Whether constructed solely from inherently buoyant means as are traditional life vests, or constructed from a hybrid composition of inherently buoyant and partially inflatable, or constructed from purely inflatable components, the specific location of a minimal amount of ballast in accordance with the construction herein disclosed would confer dramatic improvements in bulk, cost and compliance and consequently, in safety and survival statistics at sea.

The prior art on the use of dual chambered safety vests includes Swedish patent #203592 issued to Lindqvist on April 1966. This patent discloses a dual chambered product with a large forward chamber which would allow the victim to be stabilized in either a heads up position or if unconscious the victim could be stabilized lying over the forward float with their nose and mouth underwater. The device also relies on the victim's legs to apply tension to a draw string to pull the rear chamber up behind the victim's neck. For the active participant the product may have some utility but would be unsuccessful if not closely regulated. In addition the product is needlessly large and thus unnecessarily bulky when deflated, a feature that often results in the product being stored in a locker rather than being worn.

The buoyancy compensator is a convenience product that has unfortunately replaced the diver's safety vest. The buoyancy compensator is a specific adaptation of a purely inflatable safety product that is worn by the diver for use both at the surface and underwater. The product evolved from the orally inflated safety vest that had the appearance of and was often called a horse collar vest. After decades of diving it was decided that the diver would benefit from the

EXHIBIT C Page 36 of 67 pages

US 6,558,082 B1

3

inclusion of a chamber to hold air while under water to offset the loss of buoyancy that occurs as the diver's thermal protective gear is compressed at depth. The initial compensators for this shift in buoyancy were containers that could be filled with air to displace water and therefore generate increased buoyancy as the diver's wet suit was compressed by the water. In an emergency this device could be easily disconnected from the diver.

The next step in the evolution of the buoyancy compensator was to use the air cylinder to inflate the safety vest, a product designed to protect the airway at the surface. Its proximity to the face and neck, its obstruction of the chest and therefore the site of controls for the dry suit diver, its general bulk and appearance left room for the advent of the life vest style buoyancy compensator. The initial detached, canister buoyancy compensators were of low volume and easy to ditch. The horse collar and then the life vest style buoyancy compensator became voluminous. The larger lift capacity became equivalent to the better the product. Buoyancy compensators are available with 80 lb. lift capacities. At the surface the high lift product conferred a sense of security because it would buoy the diver far above the water as long as diver remained in firm control of the product. As the diving population became more diverse in health and age, the false sense of security led to marked competitiveness over the amount of lift that could be attached to the diver. The product is so confused with security that a diver can not get onto a dive boat without wearing a high lift buoyancy compensator for "safety" reasons.

The inflatable products worn by scuba divers as disclosed in Greenwood's U.S. Pat. No. 3,436,777; Robert's U.S. Pat. No. 3,747,140; Walters' U.S. Pat. No. 4,016,616; Wright III's U.S. Pat. No. 4,137,585; Scott's U.S. Pat. No. 4,176,418; Maness's U.S. Pat. No. 4,324,234; or Courtney's U.S. Pat. No. 4,645,465 and 4,681,552, and all buoyancy compensators in the prior art are complicated by the attachment of an air cylinder that undergoes shifts in buoyancy throughout each dive as the cylinder empties and becomes more buoyant. The size of the shift in buoyancy is directly proportional to the size of the cylinder used. The nature of the shift in buoyancy, whether the cylinder ends up positively buoyant or only less negative, is a combination of cylinder composition, most commonly aluminum or steel and the water density, fresh, brackish or salt. Some air cylinders become six pounds positively buoyant when empty in sea water. This cylinder will float on its longitudinal axis as will the diver who is attached to that cylinder. Consequently, if for any reason the diver is unconscious, such as from a minor embolism from rapid ascent, blackout, trauma, medical problem or just over exhausted after being stranded at sea, they will eventually lie along side the air cylinder with their airway under the water and statistically the deaths are recorded as drowning. The current management of the life threatening side righting moments of every vest style buoyancy compensator is to disclaim liability for keeping the airway out of the water.

The instant invention discloses the integration of a very small amount of non-releasable weight exactly opposite the diver that converts the only inflatable worn by divers into a product that will protect the airway if the diver is unable to. The attachment of weight to the air cylinder in the prior art has been a way for carrying the ballast necessary for the diver to be able to submerge, and thus were designed to carry significant amounts of weight. Patents issued have turned on the design of the release system. The dive community demands that the attachment of significant amounts of weight must be able to be quickly released by one hand, by

4

either hand. The release mechanism must be sure in that it must not accidentally release, but once the diver chooses to release the ballast the mechanism must be simple enough that it will not fail. All of the prior art by way of its incorporation of reliable release mechanism assures the diver that as an emergency is evolving and their weights are dropped to gain a better surface attitude, the air cylinder that was critical for use under water and is now empty will be attempting to float the diver on their side. If the diver is unable to oppose this action, their nose and mouth will be forcefully submerged.

It is to be noted that in U.S. Pat. No. 4,455,718, the quick release means is positioned centrally to allow access by either hand in the event of an emergency release. Prior to the release, the central positioning of the quick release mechanism necessitates that the weights as demonstrated in FIGS. 1 and 2 and be placed off center, potentially reenforcing the side righting moments of the life vest style buoyancy compensator. The keel retaining system disclosed is built into the buoyancy compensator so it will not be lost or left at home, the buoyancy compensator cannot be safely used without this critical component. In patent U.S. Pat. No. 3,670,509 it is noted that the ballast is located in front of the tank, close to the back of the diver and consequently closer to the axis of rotation which parallels the spine of the diver, thereby drastically reducing the rotational energy generated per unit of keel weight. This greatly reduces the effective strength of the angular rotation generated by a particular amount of ballast. Since some divers in the tropics may dive with only a few pounds of weight, it is important that the keel weight be kept as far away from the axis of rotation as is possible to maximize the strength of the righting moment. The critical location is on the exact opposite side of the tank from the diver. U.S. Pat. No. 3,670,509 refers to "substantial reducing" the tendency to force the diver face into the water. Use of the disclosed improvements will not allow the face to remain underwater. The ballast in patent U.S. Pat. No. 3,670,509 that attempts to reduce the face down righting moment, positions the diver so that they are able to "... activate the weight release mechanism.", with the loss of the ballast the diver then would be back to floating on their side with their airway underwater. U.S. Pat. No. 3,967,459 locates the weight system inferior and adjacent to the diver nearly the exact opposite as disclosed herein. It is also noted that this weight system is intended to be released in an emergency reestablishing the tendency of the cylinder to submerge the diver's airway. The integrated ballast system of U.S. Pat. No. 4,752,263 is similar in that it is releasable, and located inferior and adjacent to the diver allowing for an airway endangering surface position. The ballast system disclosed in U.S. Pat. No. 2,120,420 places weight symmetrically about the diver which would totally eliminate any heads up righting moment and in fact would stabilize the diver 50% of the time in a face down position, additionally, this system is not designed to be used with an air cylinder, but rather a surface supply air system.

The instant invention achieves many critical features including providing that the weight be permanently attached, so that in an emergency it cannot be dropped. Since the keel weight must be small enough to not compromise surface safety, it must be located on the cylinder exactly opposite the diver where it generates the maximal rotational energy per pound of keel, rotational energy desperately needed to repeatedly turn the unconscious diver over onto their back against minor righting moments caused by limbs, variations in body density, and attached gear. In particular, if the victim dives near heavy surf where the waves can flip

5

a victim over onto their face, a strong heads up righting moment is essential.

Another critical problem with the use of all current buoyancy compensators is that they combine high lift surface flotation needs with low lift underwater buoyancy needs. That same device at depth entraps pressurized air by design. The 190 lb. diver at 120 feet underwater requires nine pounds of air in their buoyancy compensator due to compression of their cold water wet suit, should that diver begin an uncontrolled ascent because; their regulator malfunctions, their tank is empty, they lose their mask and become disoriented, the power inflator sticks on their buoyancy compensators, they suffer a minor medical problems as they attempt an emergency ascent, for whatever the reason, as the diver ascends, the air in their buoyancy compensator begins to expand. Ten pounds of air at 99 feet underwater, increases to 13.3 pounds at 66 feet and increases to twenty pounds at 33 feet and doubles forty pounds during the last 33 feet of the water column, enough air to create excessively fast ascent rates.

Recommended safe ascent rates are in the process of being reduced from 60 feet per minute to 20-30 feet per minute. A buoyancy compensator that can contain 30 lbs. of air can accelerate a diver who is stationary less than 10 feet underwater to the surface at average velocities over the last 4 feet, in excess of 200 to 250 feet per minute. Ascent rates from greater depths or ascent rates with larger buoyancy compensators such as currently available products generating 40, 60 or 80 lbs. of lift are unknown. It is known that if a person's lungs are fully inflated and they hold their breath while ascending three and a half (3½) or four (4) feet, their lungs will rupture. Pulmonary barotrauma introduces air into the circulation where it can obstruct circulation and result in infarction of the tissue involved. Since the diver is often vertical during an uncontrolled rapid ascent, the embolism most often travels to the brain. Unless the diver is re-compressed within minutes damage is permanent and possibly fatal. The prior art on buoyancy compensators, as is practiced in the diving community, unfortunately combines low lift buoyancy compensation needs with high lift surface flotation. The prior art buoyancy compensator is in desperate need of the many advances disclosed herein.

Once the conscious or unconscious individual is supported safely at the surface with their airway free and clear, the next major threat to the water borne victim whether recently returned from the depths or a survivor of a common carrier accident such as an airplane crash, is from; not being seen by search and rescue efforts, of being drowned while attempting a rescue or from hypothermia.

The rapid lowering of the body's core temperature results in interruption of life sustaining cognitive activities such as staying in a tucked fetal position, which further aggravates heat loss. With the loss of cognition the victim stops monitoring and responding to changing surface conditions. Inevitably hypothermia interferes in brain stem activities such as musculoskeletal tone and respiration. It is widely known that hypothermia is the actual killer in most accidental immersions. In response to such knowledge, exposure suits have been developed to insulate individuals and preserve core temperature thus extending survival from minutes to hours. An effective exposure suit is a large, bulky item that is prohibitively expensive. Despite these serious drawbacks it is the only alternative to dying from hypothermia within minutes and as such it is a legally mandated safety device for the industrial sector where its costs, bulk and inconveniences can be borne. Exposure suit costs and bulk have prevented their use being required in the recreational, civil-

6

ian or commercial carrier sectors such as airlines, liners, ferries etc. Therefore it is clear that despite recognition that hypothermia is the active process in death at sea, there has not existed until this time a viable, affordable, storable means to control hypothermia.

To address this deficiency in the prior art, the current invention addresses both aspects of safety at sea. Rescue can rarely be performed within minutes. Often the sailor on watch is not missed until the next watch, obviously the single handed sailor is never missed. The sinking of a civilian or commercial carrier is often unattended for many hours or longer. As is noted in Harrigan's U.S. Pat. No. 2,114,301; Bennett's U.S. Pat. No. 3,105,981; or DeSimone's U.S. Pat. No. 4,187,570, there exists complex, bulky and costly means whereby jet pilots and navy personnel have personal power inflated life rafts. These automatically inflated life rafts require a cylinder whose cost alone is prohibitive to private and commercial carriers. The bulk of the cylinder, the bulk of the raft constructed from a fabric capable of withstanding pressurized inflation and high impact forces results in a device that is incompatible with civilian and commercial carriers such as airlines or ferries, yet alone individuals wind surfing, fishing from rubber rafts or touring ocean kayaks.

SUMMARY OF THE INVENTION

The present invention relates to water safety gear including life vests, integrated rescue products, and hypothermic protective gear, adapted for one-time use by the victim placed in the water by accident or for regular use by the water enthusiast whether a sailor or scuba diver.

The smallest safety vest that reliably protects the victim's airway is ideal because of its lower cost, reduced bulk when deflated, and improved appearance, all factors that contribute to compliance with use, the true basis of success in any emergency. The current water safety vest distinguishes the two critical points of buoyancy, one behind the neck and head with the second point of buoyancy being in the area of the umbilicus, and one of ballast, behind the victim and their flotation chamber. A very small amount of buoyancy and ballast securely attached to the victim at these two points is sufficient to roll an individual over and put them on their back, thereby protecting their airway from submersion. Entry and adjustments are from below, from the side or if from the front then the front chamber must overlap and be maintained and secured in a central position. Only this combination of small buoyant chambers reliably creates safe positioning of the victim's neck and head. This face up righting moment is generated regardless of the angle of entry into the water or level of conscious participation. This strong righting moment also compensates for the ongoing effects of rotational forces such as waves that at a certain point will overcome the lateral stabilization provided by the rear perimeter chamber.

Ideally the rear chamber is constructed to cradle the head and neck preventing it from drooping over backwards or sideways and becoming submerged. The chamber can be extended along the sides where they act much as outriggers, stabilizing the body from being rolled over because of wave action. The perimeter rear buoyant chamber defines a space, and actually forms a containment means for stowing a separating flotation chamber, such as a multi-function rescue safety product. It also is the ideal site of expansion that occurs when an inflatable life vest is actually inflated. All inflatable buoyant chambers upon inflation convert from a two dimensional product to a space occupying three dimen-

EXHIBIT
Page 36 of 67 pages

sional object. This creates a shortening that results in con-
 striction. Power inflated vests generally have an over pres-
 sure valve to protect against rupture but before this is
 actuated an unacceptable amount of pressure is applied to
 the thorax of the wearer. To compensate for this either the
 garment is very loose so that when it is inflated the wearer
 can still breathe or the chamber slides along a retaining strap
 or belt shifting the position of the inflatable bladder and
 thereby shifting the righting moment. Current inflatable
 vests upon inflation slide to the rear as an accommodation to
 the front entry. This pulls the buoyant means towards the
 back and results in greater moments of stability in the side
 high position which submerges the airway. In the current
 embodiment if the vest is entered from the front its closure
 is fixed. The rear buoyant chamber upon inflation stretches
 away from the center of the back and out towards the sides
 strengthening the lateral stability of the vest and the forward
 central buoyant bubble remains aligned along the center.

There are several reasons that most life jackets are vest
 style; the historical basis of clothing design, the need to
 locate the required amount of lift required by the regulatory
 agencies and the degree of fit. The buoyancy generated by
 the life vest must be able to be secured reliably about the
 torso of the wearer. Entry into the water or rough surface
 action must not strip the life jacket from the victim, in this
 regard the secure closure, appropriate sizing and an elastic
 component combine to provide a reasonable attachment.
 The only way to be assured that the victim and their life
 jacket will not be separated is by the inclusion of a crotch
 strap. Once again compliance is a function of comfort. If the
 crotch strap is loosely attached prior to entry into the water
 then easily adjustable while in the water, it might be used.
 A wet, limp, unconscious victim being tossed about by
 waves will require a retaining strap between the legs to
 optimize the survival value of any buoyant product attached
 to the victim. Its inclusion in a life saving system is
 necessary, the option of its timely use is a function of
 comfort and cosmetics. Another reason for the current vest
 design of water safety products is that the Coast Guard use
 to require certain amounts of buoyant lift for varying classes.
 Commercial requirements exceed those for personal use, but
 all classes displace such a large volume of water that the
 buoyant means needs to be spread out over a large surface
 area such as is provided by a vest style life jacket
 configuration, despite its serious drawbacks.

Some vest style life jackets have four righting moments;
 face up, back up, left side up and right side up. The current
 invention creates a broad base triangle. Central to this
 invention's uniqueness is a small buoyant bubble that is
 centrally located in front of the wearer, and a small amount
 of ballast posterior. The front chamber is responsible for
 initiating the righting moment and the counterweight elimi-
 nates the side position, and supplies the rotational energy
 needed to roll the victim over onto their back thereby
 assuring that the victim's face will be out of the water
 regardless of the angle of entry. Once the forward chamber
 has reached the surface, it in conjunction with the dynamics
 of a limp unconscious body, will oppose any tendency for
 the waves to roll the victim over into a face down position
 that would compromise the airway. If the front chamber is
 too wide, it can combine with the rear buoyant bladder and
 create a second, life threatening righting moment in which
 either side could be held at the surface and concomitantly
 the airway submerged. In summary, the rear buoyant chamber
 provides a base of support for the head and neck, supporting
 the airway and providing lateral stabilization, opposing
 rotational motion of the waves from over turning the victim

into a face down position, but in the event that occurs, the
 forward buoyant bubble that is located at the umbilicus will
 automatically flip the victim back over onto their back,
 reestablishing the heads up orientation.

While the forward and rear buoyant chambers could be
 constructed form a single chamber, ideally two or more
 chambers confer several advantages. In this design one of
 the chambers is retained by a releasable system. This feature
 allows the wearer the option of being able to remove a
 chamber and use it as a distress marker, thus the preferred
 embodiment is to construct the forward chamber from a
 highly visible and radar reflective material. Separation also
 allows the chamber to be used as a rescue device. It can
 function as a rescue board to approach a swimmer in distress
 or used as a buoyant assist beneath the arms of the rescuer
 to provide lift in the event the rescuer is attempting to
 perform artificial respiration while in the water.

In adapting the product for the scuba diver, the separating
 chamber can be used under water by the advanced diver to
 mark a dive site such as in search and rescue attempts. The
 separating bladder can also be used as an underwater lift or
 salvage device rather than the common but unsafe practice
 of using the divers high lift buoyancy compensator as a
 salvage device. In the event that the object being salvaged
 slips from the divers grasp, the diver suddenly becomes
 markedly buoyant and is thrown into an uncontrolled ascent.
 In the event of a sudden increase in boat activity the diver
 could leave the separating chamber at the surface marking
 the dive site, so that boaters will avoid driving over the
 partially submerged diver. The universal retaining strap of
 the releasable chamber ideally has an elastic component to
 allow for distention of the bladder when it is inflated. The
 separating chamber when modified for use underwater in a
 buoyancy compensator must be reliably regulated. Safe and
 secure containment of the bladder underwater is critical. As
 helpful as additional buoyancy is at the surface, that same
 buoyancy underwater represents serious exposure to rapid
 ascent with its numerous serious problems. On the other
 hand the surface flotation chamber must also be simply and
 quickly deployed to be of assistance of an emergency at the
 surface.

Because the volume of the buoyancy compensator has
 been reduced to mitigate the chances of rapid ascent, it is
 foreseeable that the forward surface flotation chamber may
 not be deployed in an acute emergency underwater so the
 rear chamber and the disclosed keel weight have to be
 sufficient to protect the airway by establishing a heads up
 orientation with or without the deployment of the forward
 chamber.

When an air cylinder is attached to the heads up life vest,
 the life vests counterweight must increase in size to offset
 any additional outrigger effect. It is called a keel, because
 when the diver is lying face down at the surface and goes
 limp, the tank compensating keel weight, like the keel of the
 sail boat will roll the diver over onto their back, stabilizing
 the airway out of the water. The compensating portion of the
 name is because the size of the weight is in proportion to the
 type and size of the vest, cylinder and whether the water is
 fresh or salt. If the cylinder when empty is neutral to slightly
 negative it will sink allowing the diver to roll over onto their
 back. The keel weight in other words compensates for the
 buoyancy shifts of the diver's jacket and air cylinder. If
 the cylinder remains negative when empty then the keel weight
 can be smaller but still must generate sufficient angular
 momentum to offset the secondary righting moments gener-
 ated by an imbalanced weight belt and attached gear or
 bladders. If the keel weight is used as an adaptation to

EXHIBIT C
 Page 32 of 67 pages

existing vest style buoyancy compensator, then it has to be strong enough to overcome the side righting movements generated by the common practice of using buoyancy under the arms.

Central to the tank compensating keel weight's design is that it be made of a very dense material such as lead, and be located exactly opposite the diver on the back side of the tank. Traditionally the buckle that generates pressure on the belt that attaches the buoyancy compensator to the tank is located in the center at the back of the tank. Because the posterior central position is so critical for the performance of the keel, the buckle has to be moved off center. This shift in the cam buckles location results in a slight inconvenience in terms of reduced access but is necessary to preserve the critical location and therefore the righting moment of the compensating keel weight.

Ninety (90%) percent of drowned divers are often found with their weight belts still on and fifty (50%) percent of such are at the surface. Usually the weights are located along the waist and the amount runs from a couple of pounds to more than forty pounds. As the amount of weight increases, the keel weight needs to be located higher up the air cylinder to offset the placement of the weight belt. The dual tank band allows for a wide variation of weight placement. Obviously, the keel weight could be incorporated into the metal of the cylinder, adhered to the cylinder, enclosed in a covering of any sort, or even attached with magnetism. A pouch or cylinder could be used to contain lead shot or beach sand as long as it is located along the longitudinal axis of the cylinder and thereby serves to generate the heads up righting moment.

Additionally the concept of critical ballast is such that a certain amount of ballast is absolutely required in order for the diver to stay underwater. To facilitate the concept of safe diver weighting the tank compensating keel weight is also used to offset the inherent buoyant material from which the buoyancy compensator itself is constructed. Thus, because of the tank compensating keel weight, the buoyancy compensator, the tank, and regulator combination is neutral and as such does not contribute to the consolidation of additional ballast on the weight belt. If the quick release buckle of a consolidated weight belt should snag on a plant or slip out of hand during adjustment at depth the dangers of an uncontrolled buoyant ascent are somewhat mitigated because the shift in buoyancy is reduced by the amount of ballast used as a tank compensating keel weight.

While the forward chamber is not critical for protecting the airway of the scuba diver because of the effectiveness of the tank compensating keel weight, the forward chamber's ability to provide additional high lift surface flotation fulfills an expectation in the sport. The key to the addition of high lift surface flotation to the diver underwater is its safe regulation. The operation of the forward chamber requires diametric opposed properties of the valve chosen to regulate the chamber. One embodiment employs the use of a variable fabric valve fabricated from a self releasable hook and loop fastener such as VELCRO® that can operate in three different modes, as a manual on/off valve, semi-automatic valve or a fully automatic valve. In addition, as the fabric valve ages its strength can be renewed by further increasing the interactive surface area.

The value of including a variable valve in line between the rear chamber and the forward chamber is that the diver can become more responsible with experience and training for the total amount of lift available to the diver underwater as well as at the surface and thus more responsible for uncon-

trolled ascent rates and consequently the risk of pulmonary barotrauma, arterial gas embolism and its frequent outcome cerebral infarction as well as the risks of decompression sickness.

Some dive instructors fear that the beginning student will not be able to perform an additional task in an emergency and therefore prefer that the entire buoyancy system automatically inflate choosing simplicity of operation at the expense of exposing the beginning diver to the consequences of a more rapid uncontrolled ascent, despite the fact that deaths have occurred during buoyant ascents while training in a swimming pool. In particular, since the student will be involved in a lot of surface drills and exercises, such as determining how much weight they require in order to be able to submerge, clearing their masks and snorkels, and since the first dives will be shallow, the consequences of rapid ascent are severe. As their experience grows and their comfort in the water with their gear and the concepts of correct weighting develop, they will be making deeper dives where the consequences of sudden ascent continue to mount and become progressively more severe. As the student begins to submerge and the lungs become more pressurized the manual operation mode of the valve is necessary for the diver to safely regulate the total amount of lift attached to their body underwater and thereby mitigate one of the major risks of diving.

As the buoyancy compensator is reduced to a device dedicated to contain the small amounts of lift actually required while underwater, some instructors are concerned that the diver will not be able to rely on the buoyancy compensator for a buoyant ascent. The problem with buoyant ascents is that they are very difficult to control when all the divers' faculties are intact. In an emergency the ability to regulate a high lift buoyancy compensator at depth is very unlikely. Optionally, one of the forward chambers can be a low volume chamber designed for emergency ascent which has incorporated a rupture plug, disc or weld so that if the product is deployed unintentionally by use of a CO2 cylinder or the divers air cylinder, or accidentally, it will self destruct at a preset pressure differential, limiting its buoyant assist to the first leg of an emergency ascent allowing the diver a second chance to regain control and reduce their velocity to a safe rate. Some of the larger high lift surface flotation chambers may never fill to rupture so its containment system that regulates its inflation must be very secure to be assured that it will only be deployed intentionally, otherwise the diver would be in the same high lift rapid ascent predicament that they currently find themselves in with today's product.

Incorporated within the multi-chambered heads up safety vest is a multi-function rescue safety product which can culminate into a raft for removal of the victim from the water and thereby confer protection from hypothermia. The needs and use of this rescue safety product determines its requirements for durability which in turn determines the type of fabric, its storable volume and therefore the location of the rescue product within the safety vest. The primary flotation device or life vest stays secured to the individual to assist them during their entry, and support them while they are deploying the rescue product. Once inflated if the product is not needed for rescue or signaling, the rescue product evolves into a raft that the individual can crawl into. The life vest remains on the victim protecting the individual should they be washed overboard as well as insulating the trunk, further helping to maintain core temperature.

The need and uses of a rescue device varies with the application. For the civilian airline passenger suddenly

EXHIBIT
Page 90 of 171 pages

US 6,558,082 B1

11

thrust into a survival situation, they are provided with a floating cushion or a lightweight inflatable life vest. In this situation a single use, ultra lightweight product is ideal. Such a rescue product might be constructed from an all welded mylar film. A multiplicity of layers would confer separate air chambers within the product providing for insulation, conferring a puncture protection while remaining small enough to fit inside a seat cushion or within a pocket of a purely inflatable life vest. To facilitate the single use products operation the oral inflator would lead to a manifold which could be constructed of differing diameters and/or which would pass through separate one way check valves of differing relief pressures. The diameter and/or pressure relief valves would direct the flow of air such that the chambers could be inflated sequentially. As pressure in the system builds up after inflating the first air chamber the second begins to inflate. The arrangement would allow for the inflation of a life ring first, followed by the rescue float, then if necessary a large outer tube would convert the rescue product into a raft with a canopy arch. The mylar, in addition to reflecting the radiant energy back towards the victim, is mirrored so that it is highly visible and radar reflective both of which would facilitate search and rescue. It structurally would resemble a single use raincoat. With the advantages conferred by this invention the victim could be of assistance to themselves and to others. Survival would be increased from minutes to days, dehydration would become the next serious threat to the survivor. An off the shelf plastic solar still could be easily included for trans-oceanic passages.

The water enthusiast on the other hand may find themselves in the water more often than the civilian airline passenger and their needs may tolerate slightly more bulk from the stored rescue product in exchange for reusability. The bulk increases because of the demands of a more durable and reusable product requires a more substantial choice of fabric. As the bulk increases, the location for stowing the rescue product becomes more critical. The ideal location is built into the back of the life vest where it is out of the way but securely and accessibly stowed until needed. In this posterior and inferior position the actions of the new and improved life vest are retained, that is the perimeter of the torso is supported by the rear inflation chamber of the life vest, stabilizing the victim against inadvertent rotation to a face down position. The location of the raft, is ideally within the walls of the life vest, protecting the raft from the shearing forces of entry, freeing the hands to assist entry and recovery once in the water. An envelope for containing the rescue product could be provided so that it could be attached to the inside or outside of any current life vest and thereby confer the protective advantages to all owners of a life vest without having to incur the cost of buying a new life vest. This would allow all current owners of a safety vest to upgrade to a dual chambered separating water survival system. This attachment system employs a hook and loop fastener looped through the arm holes and is universally adaptable to all life vests, of all sizes. Any releasable fastener such as buttons, zippers, snaps, hook and loop, etc. would allow for the rescue product and its stowage and release system to be located comfortably centered both up and down as well as side to side. While it could be positioned outside the life vest, its inclusion within the life vest will ensure its secure attachment. The inflation of the rescue product is determined by its use, cost, and available stowage space but since oral inflation is not restricted by shelf life, it is always present and most affordable. Inflation via a manifold will allow the rescuer to provide a rapidly inflated life ring to help stabilize the victim through the initial insult and then provide a float

12

while the remainder of the chambers are inflated. In the current embodiment the rescue product is built into the safety vest or floating cushion, if anyone in the water intentionally or accidentally and is sequentially inflated through a series of rescue products that culminates in a raft for removal of the individual from the hypothermic effect of the water.

An additional advantage of the disclosed invention is directed to the adaptation necessary when the safety vest is used underwater by the scuba diver. In this application the heads up safety vest would be called a buoyancy compensator or BC. Because of the serious consequences of rapid ascent on pressurized lungs, in addition to the reliable regulation of the high lift surface flotation component of the buoyancy compensator, the primary buoyancy compensation bladder should be variable size. By design the buoyancy compensator is to be used underwater where it is vulnerable to inflation from entrapped pressurized air at two to three atmospheres, as well as subject to inflation from panicked misuse or mechanical failure of the power inflator, all causes leading to the same result, dangerously rapid ascent rates. The volume of the bladder should be tailored to the dive environment. The dedicated buoyancy compensator can be adjusted to the lowest volume needed to accomplish the goal of compensating for compression of thermal protective gear and the resultant loss of buoyancy. As the dive environment changes, so does the need for thermal protective gear. In tropical water minimal or no protective gear is worn and therefore the diver has nothing to compress and so experiences no loss of buoyancy at depth. For the diver in a bathing suit, the need for a power inflatable bladder underwater is limited to the shift in buoyancy that occurs in their air cylinders, and usually is well under 5 or 6 pounds of lift. This chamber is only needed to cover the initial overweighting needed to allow the diver to be neutral at the end of the dive in order to make a safety stop. This product should not be called a buoyancy compensator as a first step in reeducating the diving population about the dangers of power inflatables underwater.

In cold water, at 120 feet of depth, a 190 lb. diver in a ¼ inch neoprene wet suit experiences a loss of 9 lbs. of lift due to compression of the wet suit. Most sport divers are smaller and therefore are wearing less neoprene, dive in warmer waters and/or making shallower dives. There is no justification for subjecting a diver to unnecessary risks of rapid ascent. Due to the extreme danger of pulmonary rupture and secondary air embolism that results from a rapid uncontrolled ascent it is imperative that the buoyancy compensation chamber be restricted to the lowest volume absolutely necessary to accomplish its goal. Any lift over and above the minimum amount exposes the diver to unnecessary risk. The diver doing repetitive dives in one day is advised to do their deepest dive of the day first and will need a buoyancy compensation capacity commensurate with their thermal protective gear and dive plan. As the dives become shallower and consequently warmer as well, the volume of an adjustable buoyancy compensator can be reduced, and consequently reduce the divers exposure to the risk of rapid ascent. Recommended ascent rates are dropping from 60 feet per minute to 20-30 feet per minute. The medical literature notes that a 30 lb. buoyancy compensator can produce average velocities in excess of 250 feet per minute from less than ten feet under the water. For several generations, divers dove without a buoyancy compensator so its use cannot be construed as critical. The advent of this convenience product has resulted in ballistic ascent rates because of the air entrapped inside the product which is pressurized at depth

US 6,558,082 B1

13

which then doubles and possibly quadruples upon ascent depending on the initial depth. An inexperienced diver in an "out-of-air" situation is prone to forget about the intellectual concept of arterial gas embolism in the hypoxic and hypercapnic driven race to the surface, only to die from an arterial gas embolism before ever getting a chance to drown. Drowning is a slow, reversible process that lends itself to rescue for quite some time after the event, unlike arterial gas embolism. When using an adjustable dedicated buoyancy compensator the diver can very precisely control their exposure to the dangers of an emergency ascent through the water column and thereby significantly reduce the risks of rupturing a lung and suffering an arterial gas embolism to the brain or heart or similarly reduce the risks of suffering the bends because of missed decompression stops.

An alternate location for a separating forward surface flotation chamber is for its inclusion within the shoulder straps. The redundant personal flotation device is designed to be separated away from the remainder of the dive gear to provide complete duplication of personal flotation devices in the event of failure of the primary chamber. The chamber can also be used as a rescue, signaling, salvage product or snorkeling vest.

Appropriately sized releasable shoulder trim weights offset the operation of the buoyancy compensator underwater, improving swimming position, decreasing frontal area, producing less hydrodynamic resistance and consequently less diver fatigue. Once again, the shoulder trim weight results in a reduction of the consolidated weight belt with its inherent advantage of protecting the diver from accidental loss of all ballast at one time.

In summary, a multiple chambered life vest can be of a low volume, low lift, and low profile design as long as at least two points in need of buoyancy are covered, behind the neck and at the umbilicus and one point of ballast along the vertical posterior axis. Excessive buoyancy can be extremely detrimental either because the product is not actually worn because it is too bulky or because side righting moments have been created that jeopardize the airway. The separating chamber in the hands of a conscious, capable user can be removed providing a signaling device for facilitating search and rescue efforts or used as a rescue board minimizing the risk associated with attempting to rescue another victim who has become hypoxic. After the initial insult has been survived the user can deploy the incorporated inflatable rescue product that sequentially inflates into a life ring, then rescue board and distress marker and culminates in a raft to remove the victim from the water with its inevitable and often rapid hypothermia. The entire water safety survival system constructed for a single use application could easily fit within the air line seat cushion, dramatically improving survival statistics for accidents at sea.

The multi-chambered heads up safety vest as adapted for the scuba diver allows for reliable segregation of a variety of high lift surface flotation chambers while underwater. In addition a variable volume dedicated buoyancy compensator allows the diver to further reduce the amount of lift attached to the smallest amount necessary for a particular dive environment. The combination of these two improvements will markedly reduce the largest cause of pulmonary barotrauma, and secondary embolism, a major cause of injury and death in the field of diving.

The inclusion of a couple of pounds of weight integrated into the posterior axis of the victim's vest will allow the victim to overcome numerous minor righting moments that can place the airway of the exhausted or distressed victim

14

under the water leading to drowning another major cause of death in the sport of diving. The benefits of the tank compensating keel weight are so dramatic that they can be included into a separate product that can retrofit existing buoyancy compensators, converting them into a heads up product. The inclusion of the multi-function rescue product within the walls of the buoyancy compensator confers on that diver the ability to respond to a number of problems frequently encountered by the diver in rescue, marking and salvage.

Thus, a water safety and survival system that provides a multi-chambered personal flotation device that operates on minimal volume to create a single heads-up righting moment that reliably stabilizes an unconscious victim with his airway out of the water is disclosed in one embodiment. This is accomplished with a minimal amount of lift, less deflated bulk, improved cosmetic appeal, and reduced cost. These combined advances result in a safety vest conducive to actually being worn, a key feature for a safety vest. The system also provides for incorporation of a separating second inflatable life ring, rescue board, artificial respiration assist platform, and ultimately a raft for removal of the victim from the water to protect him from hypothermia. This sequentially inflated, multi-chambered, multi-faceted inflatable rescue product is incorporated within the body of the safety vest. The incorporation of a wide range of rescue products into the body of the person flotation device will reduce the incidence of that dual tragedy that occurs when the rescuer becomes the second victim. This water survival system, when adapted to the special needs of the scuba diver, requires the incorporation of a tank compensating counterweight to offset the deleterious effects of a buoyant empty tank whose buoyancy can force the diver's airway under the water. Further adaptation for use underwater also includes a system to adjust the volume of the primary buoyancy compensation chamber and variable valve for segregation and reliable regulation of one or more additional surface flotation chambers underwater. The design of the separating chambers coincides with responsibilities and goals of the diver. These and more modifications for the safe underwater use of the heads-up safety vest are critical in order to mitigate the risk of rapid ascent and its consequences, arterial gas embolism and decompression sickness.

In accordance with these and other objects which will become apparent hereinafter, the instant invention will now be described with particular reference to the accompanying drawings.

BRIEF DESCRIPTION OF THE DRAWINGS

FIG. 1 is a view of a personal flotation device shown incorporating the multi-function rescue product within the back wall of the vest.

FIG. 2 is a view of an existing buoyancy compensator with the multi-function rescue product attached.

FIG. 3 is a view of an airline life vest carrying a multi-function water rescue safety product.

FIG. 4 is a view of an airline seat cushion modified by the inclusion of an ultra lightweight disposable multi-function rescue safety product.

FIG. 5 is a view of an inflation manifold.

FIG. 6 is a top view of a multi-chambered rescue product.

FIG. 7 is a cross section view of the multi-function rescue product fully inflated.

FIG. 8 is a view of a face up personal flotation device modified for scuba diving.

EXHIBIT
Page 17 of 17

15

FIG. 9 is a view of the scuba diver with an inflated separating horse collar, and self rupturing emergency ascent chamber.

FIG. 10 is a view of the inflatable cummerbund, with a releasable forward chamber, carrying an alternatively forward chamber in the form of a float.

FIG. 11 is a view of the pyramidal structure with central forward buoyant chamber and rear buoyant chamber.

FIG. 12 is a combined view of the elements of the water safety and survival system as it is adapted to the scuba diver.

FIG. 13 is a front view of the adjustable buoyancy compensator.

FIG. 14 is a rear view of an alternate adjustable buoyancy compensator.

FIG. 15 is a front perspective view of a first counter weight member in accordance with the present invention.

FIG. 16 is a back perspective view of the counter weight member illustrated in FIG. 15.

FIG. 17 is a front elevational view of the counter weight member illustrated in FIG. 15.

FIG. 18 is a back elevational view of the counter weight member illustrated in FIG. 15.

FIG. 19 is a side elevational view of the counter weight member illustrated in FIG. 15.

FIG. 20 is a top plan view of the counter weight member illustrated in FIG. 15.

FIG. 21 is a front perspective view illustrating a first attachment embodiment for a first counterweight assembly in accordance with the present invention.

FIG. 22 is a front perspective view illustrating a second attachment embodiment for a first counterweight assembly in accordance with the present invention.

FIG. 23 is a back perspective view illustrating the second attachment embodiment for the first counterweight assembly.

FIG. 24 is a perspective view illustrating a connection portion of a coupling strap in accordance with the present invention.

FIG. 25 is a front perspective view illustrating a second attachment embodiment for a first counterweight assembly in accordance with the present invention.

FIG. 26 is a top plan view of the counter weight member illustrated in FIG. 15 having at least one suction cup.

FIG. 27 is a side elevational view of the counter weight member illustrated in FIG. 15 having a plurality of suction cups.

FIG. 28 is a front elevational view of a second embodiment counterweight assembly in accordance with the present invention in a flap open position.

FIG. 29 is a top elevational view of the second embodiment counterweight assembly with the flap removed.

FIG. 30 is a front elevational view of the second embodiment counterweight assembly in a flap closed position.

FIG. 31 is a side elevational view of the second embodiment counterweight assembly.

FIG. 32 is a front elevational view of a third embodiment counterweight assembly in accordance with the present invention.

FIG. 33 is a side elevational view of a weight member utilized with the third embodiment counterweight assembly.

FIG. 34 is a perspective view of a fourth embodiment counterweight assembly in accordance with the present invention.

16

FIG. 35 is a top plan view of the fourth embodiment counterweight assembly.

FIG. 36 is a perspective view of a fourth embodiment counterweight assembly in accordance with the present invention.

FIG. 37 is a perspective view of a fifth embodiment counterweight assembly in accordance with the present invention.

FIG. 38a is a front elevational view of the fifth embodiment counterweight assembly.

FIG. 38b is a front elevational view of a soft weight member in accordance with the present invention.

FIG. 38c is a front elevational view of a hard weight member in accordance with the present invention.

FIGS. 39a through 39e illustrate the various steps which are performed for removing a pouch member and associated weight member from a pocket member for the fifth embodiment counterweight assembly of FIG. 37.

FIG. 40 is a front perspective view illustrating a combination of counterweight assemblies in accordance with the present invention utilized together.

FIG. 41 is a back perspective view illustrating a combination of counterweight assemblies in accordance with the present invention utilized together.

FIG. 42 is a perspective view of a diver having his or her airway submerged.

FIG. 43 is a perspective view of a diver having his or her airway protected in accordance with the present invention.

FIG. 44 is a perspective view of a training device for determining proper size and location for the weight member in accordance with the counterweight assemblies of the present invention.

FIG. 45 is a perspective view of a quick disconnect member in accordance with the present invention.

FIG. 46 is an enlarged perspective view of a male portion of the quick disconnect member illustrated in FIG. 45.

FIG. 47 is a perspective view of a prior art quick disconnect member having its female portion in section.

FIG. 48 is a view of the personal flotation device shown in Figure and incorporating a counterweight member.

FIG. 49 is a view of the airline life vest shown in FIG. 3 and incorporating a counterweight member.

FIG. 50 is a view of the face up personal flotation device shown in FIG. 8 and incorporating a counterweight member.

FIG. 51 is a view of the scuba diver with the inflated separating horse collar shown in FIG. 9 and incorporating a counterweight member.

FIG. 52 is a view of the pyramidal structure with central forward buoyant chamber and rear buoyant chamber shown in FIG. 11 and incorporating a counterweight member.

FIG. 53 is a posterior view of a vest style personal flotation device ("PFD") illustrating middling mobile ballast.

FIG. 54 is a cephalic view of a victim wearing a vest style PFD illustrating the eccentric positioning of mobile ballast.

FIG. 55 is a side view of a mobile ballast attachment means illustrating numerous components facilitating mobility of the ballast member.

FIG. 56 is a cephalic view of a victim wearing a vest style PFD illustrating a freely mobile ballast within a container that redirects the ballast's movement as the victim rolls.

FIG. 57 is a lateral and cephalic view of the mobile ballast's container illustrating the multiple points of stability, as it is reoriented in three dimensions.

EXHIBIT Page 13 of 67 pages

17

FIG. 58 are lateral views of a deflated then inflated PFD illustrating stowage then deployment of the ballast member.

FIG. 59 is a posterior view illustrating a dual position minimally active eccentric fixed keel that can be released by the wearer into a maximally active mobile position.

FIG. 60 is a posterior view showing an immobilized ballast member that can be released by the wearer into an active mobile position.

FIG. 61 is a posterior view of a yoke collar PFD with an attached mobile ballast contained in a sealed semi-circular container.

FIG. 62 is a lateral view of a yoke collar PFD illustrating a PFD in accordance with the present invention constructed to accommodate a recyclable contained mobile ballast member.

FIG. 63 is a posterior view of a yoke collar style or stackable PFD illustrating an externally attached eccentric cylindrical container for a mobile ballast member that can be put in place without having to remove the jacket.

FIG. 64 is a lateral view of a yoke collar PFD showing the integrated form of FIG. 63 where the mobile ballast and containment means are embedded in the foam of the neck of the jacket.

FIG. 65 is a lateral view of a yoke collar PFD while being worn and showing multiple external pouches built into the fabric of the jacket that allow the user accessible adjustment of an amount of ballast without having to remove the vest.

FIG. 66 is a posterior view of a cervical portion of a yoke collar style PFD illustrating eccentric placement of quick release mobile ballast members, one of which can preferably be added while wearing the PFD, one of which preferably cannot.

FIG. 67 is a right anteriolateral view of a yoke collar style PFD showing an externally attached eccentric fixed ballast system that can be adjusted while wearing the PFD.

FIG. 68 is a posterior view of a thermal protective suit illustrating multiple fixed and mobile ballast and buoyant members.

FIG. 69 is a posterior view of a yoke collar style PFD illustrating a fixed hemicircumferential ballasting member.

FIG. 70 is a posterior view of a yoke collar style PFD illustrating a mobile ballast secured via multiple attachment points crossing a victim's midline within a ventilated container.

FIG. 71 is a posterior view of a yoke collar style PFD illustrating a mobile ballast secured via multiple attachment points crossing a victim's midline secured to a PFD strap but otherwise open for unlimited range of motion.

FIG. 72 is an anterior view of an individual wearing a yoke collar style PFD, illustrating an eccentric, fixed combined illumination and ballast means.

FIG. 73 is an enlarged view of a combined illumination and ballast means showing thickened high density walls, extra batteries, variably sized high density solid base plug and neutrally buoyant packing material.

FIG. 74 is a left lateral view of a vest style PFD illustrating left anterior buoyant globe appliance and posterior mobile ballast power means.

FIG. 75 is a posterior view of a vest style PFD illustrating fixed horizontal ballasting batteries connected to eccentric transmitter means.

FIG. 76 is a left antero-lateral view illustrating a two part PFD with eccentric central anterior buoyant means and second cephalo-cervical buoyant means with dual arm mobile ballasting battery means.

18

FIG. 77 is a frontal view of yoke collar style PFD foam members showing existing and disclosed alternate configurations for internal foam layers.

FIG. 78 is an anterior view of stacked foam layers preserving uniform foam thickness throughout the PFD.

FIG. 79 is an anterior view of stacked foam layers with interlocking layers which result in an increased cervical displacement relative to ventral component.

FIG. 80 is a frontal view of a yoke collar style PFD oversized and complete single piece base foam layer.

FIG. 81 is a frontal view of PFD stack layers comprised entirely from continuous single piece layers.

FIG. 82 is a frontal view of a PFD stack comprised of a single piece over sized base layer with the balance being two piece layers with the joints all on one side opposite the ballast.

FIG. 83 is a frontal view of a PFD stack comprised of single piece over sized base layer two piece layers with the joints on alternating sides.

FIG. 84 is a frontal view of a PFD stack comprised solely of two piece layers with the joints located at the posterior cervical midline.

FIG. 85 is a cross sectional view of a cervical area of a yoke collar style PFD illustrating attachment of combined ballast and appliance to oversized foam base, coated fabric shell and 90 degree two part stiffener means the lateral component of which may be constructed of high density material.

FIG. 86 is a left lateral view of a yoke collar style PFD illustrating amplified cervical displacement means relative to reduced ventral means and attachment of combined ballast and appliance member to oversized foam base/fabric shell held securely by foam layer compressing chest strap(s).

FIG. 87 is an enlarged view of a cervical-ventral joint of a yoke collar style PFD illustrating an externally attached rigid swing arm attachment of eccentric mobile ballast.

FIG. 88 is a left lateral view of a yoke collar style PFD with combined ballast and signaling device attached via an integrated 90 degree swing arm.

FIG. 89 is an enlarged view of a left lateral cervical-ventral joint illustrating the location of buoyant stop and ballasting swing ends of combined ballast and signaling device with pivoting attachment means parallel to the anterior face of the PFD.

FIG. 90 is an enlarged antero-lateral view of a yoke collar style PFD illustrating secure, rigidifying standardized integrated mounting means of combined ballast and appliance.

DESCRIPTION OF THE PREFERRED EMBODIMENTS

FIG. 1 shows victim 201 wearing a vest 203 that can function separately as a snorkeling vest, personal flotation device for boating or alternately hooked up to the primary bladder of a buoyancy compensator through quick release means 91 and hose 70 that is attached within pocket 74. Vest 203 can also be inflated through oral inflation means 72. Additionally, vest 203 can be incorporated with a ballast means 100 (FIG. 48). A multi-function rescue product and raft 207 is stowed within the back pocket of the lift vest between the outer wall 208 and inner wall 209. A retrieval strap 211 opens the pouch formed by wall 208 and wall 209, and is wrapped around raft 207 allowing the user to remove rescue product and raft 207, comprised of an expansible material allowing inflation chamber portion 73 located along the perimeter of the back to roll forward upon inflation.

EXHIBIT C
Page 44 of 111 pages

FIG. 2 shows a diver 202 adapting an existing vest style buoyancy compensator 204 to carry the rescue product 207 within a containment pouch 210, held in place by band 23 that is supported by arm holes 24. A retrieval strap 211 is wrapped around rescue product 207 so that it can be removed from the containment pouch 210 without having to remove the vest 204. The scuba tank 102 is standard.

FIG. 3 shows a typical inflatable vest 205, as might be worn by an airline passenger 201, that is strapped to the victim by strap 214, in the event of a water landing. The typical vest 205 is modified by addition of a containment pocket 213 that stows a single use rescue product 207. Additionally, vest 205 can be modified by the addition of a counterweight 100 (FIG. 49).

FIG. 4 shows an airline cushion 206 containing rescue product 207. The victim puts their arms through straps 15 to secure the cushion 206 to the victim during water entry.

FIG. 5 shows a manifold device 17 that connects an oral inflator 16 through barbed fittings 18 to a series of one-way check valves that can also function as variable pressure relief valves 19, 29, 39, 39, and 59 that connect via tubing 20, 30, 40, 50, and 60 to a series of inflatable chambers as are demonstrated in the next drawing, FIG. 6.

FIG. 6 shows a multi-function rescue product and raft 207, comprised of life ring 21 which is inflated by tube 20 which because it has the largest diameter tubing and because the pressure relief valve 19 has the lowest relief pressure setting, will inflate first. Inflation chamber 31 or the floor is the second to inflate. Chamber 41 is a second chamber in the floor and because of the setting of the pressure relief valve and/or the diameter of tube 40 would be the third chamber to fill. The first three chambers; the life ring 21, and the floor chambers 31 and 41 form a rescue board or distress marker. The next chamber is a wall tube 51 and that can be inflated while resting on combined chambers 21, 31, and 41. The final chamber 61 forms an arch, supporting a protective canopy. In its last configuration, the multi-function rescue product 207 can be inflated to a raft constructed from radar, solar, and infrared reflective material.

FIG. 7 shows construction of rescue product 207 in cross section, highlighting the various chambers and their sequence in inflation, life ring 21 first, portion of floor 31, remainder of floor 41 second, high volume tube wall 51 third, arch canopy tube 60 last. Ideally, the floor is doubled or tripled to provide thermal insulation from the water and puncture resistance.

FIG. 8 scuba diver 202 is shown wearing a heads up, multi-chambered, dedicated, rear mounted, adjustable buoyancy compensator having an inflatable chamber 85 connected with hose 83 through quick release coupling 91, and through one-way pressure release valve 82 to a releasable inflatable shoulder harness 80 that is stowed in a folded configuration. In FIG. 9, the shoulder harness 80 is inflated. In FIG. 8, an alternate or concurrent surface flotation bladder having an inflatable chamber 90 can be connected to buoyancy compensation chamber 85 by tube 93, which is regulated by one-way check valve 92, and can be separated from the diver for rescue, salvage or marking activities by quick release coupling 91. In FIG. 8, it is noted that the life vest comprised of inflatable chambers 85 and 90 is snug but releasably attached to diver 202 by a crotch strap 94. The diver 202 in FIG. 8 is holding an air hose 191 which couples to the male quick release coupling 192 on the power inflator 87, or can be used to inflate rescue product 207 of FIG. 2 or can be used as a high pressure air source for the rapid inflation of chamber 90 when it is being used in a rescue attempt. Additionally, a counterweight 100 can be provided (FIG. 50).

FIG. 9 shows an adjustable buoyancy compensation chamber 85 reduced in volume by rolling up the side chamber as shown at 130. An automatic rupturing emergency ascent chamber 180 is inflated from buoyancy compensation chamber 85 through quick release coupler 91, or by a separate compressed gas cylinder such as a CO2 cylinder 215. Standardized retaining strap 110 as found on all the interchangeable forward bladders. Strap 110 keeps bladder 180 from separating from diver 202 until the quick release buckle 103 is opened. Retaining band 104 is expandable allowing for the forward chamber to expand away from the diver upon inflation. In an uncontrolled ascent the diver is unlikely to operate the venting mechanism 183 in which case a rupture plug 182, can be provided, which crosses a weld line 181 weakening it so that as the chamber 180 pressurizes upon ascent, it will rupture out at the weakened point, thereby reducing total lift attached to diver 202 and helping to control the ascent velocity. In FIG. 10 diver 202 demonstrates two of a wide variety of different releasable forward chambers indicated generally as inflatable means 90 stored in the waist band in FIG. 8. Additionally, a counterweight 100 can be provided (FIG. 51).

FIG. 10 shows the diver 202 whose waist band 95 is retaining releasable separating forward chamber 97 which is a redundant horse collar life vest and rescue product. Expandable element 104 stretches upon inflation of the forward chamber 97. In an emergency the horse collar vest 97 can be released from the divers buoyancy compensator by quick release buckle 103. The same quick release buckle is used for releasing the shoulder strap as is standard in the art, and familiar to divers. After releasing the forward vest 97 from the waist, the diver then disconnects the horse collar life vest 97 from its source of power inflation the buoyancy compensator 85, by using the quick release coupling 91. Once the forward chamber has been separated from the rear chamber 85 and diver 202, it can be employed as a rescue board, tied off as a bottom marker, left at the surface to warn boat traffic, or held aloft as a high visibility distress marker. In FIG. 10, the diver 202 is carrying a rescue board, distress marker, surf mat as an alternate separating forward surface flotation chamber indicated as 96. Chamber 96 can be retained by guides 110 on strap 104 of the divers waist band. In FIG. 10, chamber 96 is shown with oral inflation means 98 and quick release coupling means 192 which couples to quick release coupling 91 thereby connected to the rear buoyancy compensator 85, or to the air hose from the air cylinder for more rapid inflation. Retaining flap 106 serves to store the releasable forward chamber 97 or 96. Pouch 160 is sealed by flap 161 and is used to contain a small amount of lead shot to offset the buoyancy of the materials used to construct the forward chamber as well as its containment system. On the upper shoulder straps of the diver 202 in FIG. 10, D-ring 172 is attached to hook and loop covering flat 173 that is attached to underlying fabric walls 175 to create a quick release pocket for a lead shot filled pouch 174.

FIG. 11 demonstrate the pyramidal structure of the multiple chambered heads up life vest. The vest is comprised of a rear U-shaped buoyant chamber 121 and the forward centrally located buoyant chamber 120. The triangle 123, formed by chamber 120 and 121 has a single righting moment, face up. The victim 201, and his airway 124 are maintained out of the water whether or not the victim is conscious. A counterweight 100 can also be provided with the life vest (FIG. 52).

FIG. 12 shows a composite of the water safety and survival elements disclosed herein. In FIG. 12 the diver 202 is unconscious but his airway 124 is held out of the water.

US 6,558,082 B1

21

A generic centrally located inflated chamber 105 is retained by expansible strap 104 and could be released by quick release buckle 103 if the diver was alert and it was needed for rescue or for use as a distress marker for search and rescue activities. Waist band 95 is secured in place by buckle 178 which is mounted on a Velcro® base 179 that allows the waist buckle to be adjusted along the length of the left side of the waist band 177 to accommodate the variation in waist size that occurs as different types of thermal protective gear are worn. The buckle 178 is off to the side so that the generic forward flotation chamber 105 retains its critical central location. The forward chamber retaining flap 106 is attached by hook flap 108 to the loop material that covers the entire length of the waist band indicated as strap 95. This allows the forward chamber 105 to be quickly but securely adjusted to its central position. Operation of forward chamber 105 is regulated by the variable fabric valve 171 built into the retaining flag 106. The hook and loop components 171 of flap 106 can be varied by the inclusion of a reducer strip of hook 107. The size of the reducer strip 107 determines whether the flap 106 will open quickly under pressurized inflation from the rear chamber 85, open slowly or not at all. If the entire reducer strip 107 is removed the hook and loop means 171 are of sufficient strength to lock off the forward chamber. An over pressure valve 111 is located on the opposite side of the chamber 85 so that the diver can vary the position of the power inflator from the rear to the front by interchanging the power inflator 87 and over pressure relief valve 111. Rescue product 207 is contained in a pocket built into the rear wall of the buoyancy compensator 85 and is accessible by strap 211. Rescue product 207 is attached to the diver by a releasable lanyard 212. The tank compensating keel weight 100 is permanently attached to the tank retaining strap 109. Ideally, the tank compensating keel weight 100 is of a hydrodynamic conformation, made from a dense substance such as lead, coated in a soft film such as plastic so it will facilitate keel weight 100 being securely clamped in place by cam buckle 101. The soft coating will also avoid damaging the protective coating of the tank 102. The tank compensating keel weight 100 may be replaced by a standard lead weight so that the diver traveling abroad will not have to transport a lead weight. A diver in tropical waters may only require 5 pounds to descend while use of a dry suit in cold water can require 40 lbs. or more to be able to submerge, the greater the weight of keel weight 100, the stronger the face up righting moment it will generate. As the weight belt is increased because of the use of buoyant thermal protection, it is critical the keel weight 100 be increased. Regardless of the size of the keel weight 100 it is critical that it be located exactly opposite the diver and thus its position must be adjustable so that as the diver changes between diving cylinders of different diameters, keel weight 100 can be easily adjusted, by a non-user, to maintain its critical position. Ideally strap 109 is marked with a scale 176 to guide the diver in selecting the correct placement of keel weight 100 on cylinders of different diameters. If the keel weight 100 is slightly off center, it could summate with an imbalanced weight belt and stabilize the diver in side up position which will allow the airway 124 to submerge. Because the position of the keel weight 100 cannot be compromised, the cam buckle 101 is moved to a less accessible position on the side. A waist buckle 178 is attached to a hook fastener base 179 that allows it to be positioned anywhere along the left side of loop fastener covered waist band 177.

FIG. 13 discloses one of many designs for the construction of an adjustable buoyancy compensator 85. The portion

22

of the buoyancy chamber that is held inaccessible to inflation is indicated as a rolled up portion of the buoyancy compensation chamber 130. The loop portion of a hook and loop fastener forms the inside back of the buoyancy compensator and is indicated as 131. Loop 131 serves to attach the side chamber 136 by hook strips 132 to the body of the buoyancy compensator 85. Flap 138 is formed from the forward facing loop strip 137 and the rear facing hook strip 132. As the volume of the buoyancy chamber is reduced by rolling up the side chambers, the hook strip 132 adheres to the loop strip 137 to form and secure the roll 130. Clip 196 secures the rolled up grommets to prevent the chamber from unrolling under pressure from the air in the buoyancy compensator 85. The portion of the buoyancy compensator behind the neck is indicated as 134. In the current drawings the side chambers 136 are reduced in an infinitely variable fashion and an indicator 133 informs the diver of the remaining amount of lift provided by the buoyancy compensator 85. The indicator 133 allows the diver to quickly return to preestablished buoyancy compensator lift volumes as indicated for a particular set of dive gear. Quick release shoulder strap buckles 135 rely on quick release buckle 103 and are common in prior art. The lower shoulder straps 195 rely on nylon webbing loop 194 to establish structural integrity and internal hook fastener for positioning webbing loop 194 on the loop fastener covered nylon webbing waist band 95 and 177.

FIG. 14 depicts another retaining system for reducing the volume of adjustable buoyancy compensator 85. Double sided hook strip 151 and double sided loop strap 150 are used to lock off the reduced portion of the buoyancy compensator chamber 85. Double sided hook flap 152 attaches the rolled up chamber securely to the loop covered body of the buoyancy compensator 85. The reducible portion of the buoyancy compensator chamber is indicated as 136. The portion of the buoyancy compensator 85 that supports the neck and head is indicated as 134. The keel weight 100 is threaded on tank band 109, that is secured to the air cylinder by cam buckle 101. The hook flat 161 seals off the lead shot filled pouch 160 used to neutralize the inherent buoyancy of the buoyancy compensator.

OPERATION OF THE INVENTION

In FIG. 1, the water enthusiast is shown wearing a traditionally designed vest 203 which could be used in any recreational water sport. The vest 203 contains a multifunction rescue product and raft 207 within its rear pocket. If the ocean kayaker should become separated from his kayak at sea the victim 201 could pull on lanyard 211 and remove the rescue product and begin inflating it. A releasable attachment cord 212 will keep the rescue product from blowing or washing away. Because the vest 203 includes quick release coupler 91, the vest can also eventually be used as a forward chamber with the appropriate dedicated buoyancy compensator if the user becomes certified in diving.

FIG. 2 shows that the diver 202 wearing a current vest style buoyancy compensator 204 can adapt the rescue product 207 contained in pocket 210 to be carried between the diver and the tank by use of a strap 23 which passes through the arm holes of the buoyancy compensator. Access and use of the rescue product 207 is the same as described in FIG. 6 below.

FIG. 3 shows the victim 201 of a common carrier accident wearing a traditionally designed inflatable vest 205, modified with pocket 213 which contains a single use multi-

function rescue product and raft 207 constructed from a mylar film and vacuum packed much as a single use rain-coat. After surviving the initial entry the product is inflated and used as a life ring, then rescue board or distress marker, and finally inflated to a raft if necessary to remove the victim from the hypothermic effects of the water.

FIG. 4 shows the airline or ferry safety seat cushion 206 containing the multi-function rescue product and raft 207. The victim's arms are placed through straps 15. The cushion 206 provides minimal safety in the water. The incorporated rescue product 207 would confer dramatic improvements in survival at sea.

Referring to FIG. 5, as the user exhales through oral inflator 16, the air passes into manifold 17 that connects multiple chambers to the oral inflator 16. The air is directed to the appropriate chamber according to the diameter of the tubing indicated as 20, 30, 40, 50, and 60. The one way check valves 19, 29, 39, 49, and 59 create structural integrity for each of the chambers down stream. If a puncture should occur only that chamber will lose pressure. If the oral inflator fails, the manifold 17 at its barbed connectors 18 can be disconnected from connector tubes 22 allowing separate inflation through each check valve. The simplicity of a single oral inflator will help the victim focus on a single task. Obviously, separate oral inflators could be used and the significance of which oral inflator is to be inflated first could be printed on the raft in multiple languages.

FIG. 6 is a top view of the multi-function rescue product and raft 207, fully inflated. The life ring 21 because of its small diameter is inflated first and quickly because of its low volume. This life ring could be used by the individual or extended to a family member. The floor chamber 31 and 41 would be inflated next also because they are low volume. Once inflated the first three chambers forms a float that gives the victim a sense of accomplishment. Inflated chambers 21, 31, and 41 create a four foot rescue board for approaching a flailing, distressed victim. The float can also be held aloft as a high visibility distress marker signaling other victims or search and rescue efforts. The inflated floor also gives a platform for the victim to rest on. If necessary the victim can rest on the first three chambers as they begin inflating the high volume side wall tubes 51. Once inside the raft the infrared reflective mylar would help to offset further loss of body temperature. Finally, the canopy arch 61 is inflated and the victim creates an enclosed space that is highly visible to the naked eye as well as radar. The multiplicity of chambers confers protection from puncture.

FIG. 7 is a view of the inflated raft 207 in cross section. The sequence of inflation, 21, 31, 41, 51, then 61 shows how the life ring would convert to a rescue float and ultimately to a raft.

FIG. 8 shows the scuba diver 202 holding a pressure hose 191 with its common female quick release coupler 91 disconnected from the male quick release coupler 192 of the power inflator 87. The common female coupler 91 can be attached to any of the other incorporated chambers such as the horse collar vest which is deflated and stored in the shoulder straps indicated at 80, or any of a multiplicity of deflated chambers that can be interchangeably stored in waist band as indicated at 90 or in the pocket. The high pressure hose 191 is employed to effect a more rapid inflation in an emergency. For routine operation of the chambers stored in the waist band or shoulder straps, they are in fluid communication with the buoyancy compensator chamber 85 through quick release couplers 91 and check valves 92. The crotch strap 94 is the only way the user can

be assured that he will not be separated from his inflatable rescue product in heavy surf. With the auxiliary chambers deflated and stored, the diver has a sleek profile with reduced hydrodynamic drag while swimming under water. Most importantly with the high lift surface flotation chamber stored it will not contribute its buoyancy to the total lift available to the diver under water.

FIG. 9 shows a diver 202 with a redundant separating shoulder mounted horse collar 80 inflated. The diver also is demonstrating the self rupturing emergency ascent chamber 180 inflated at the diver's waist. It is to be noted that the dedicated adjustable buoyancy compensator 85 has been reduced by rolling up the lower portion of the chamber as indicated at 130. If this reduced chamber was providing insufficient lift at a depth and the diver chose to attempt an emergency buoyant ascent the forward chamber 180 at the waist could be released. If the diver was out of air, the air pressure in the rear chamber would spill forward causing chamber 180 to inflate. Alternatively, chamber 180 can be inflated from its own compressed cylinder 215 when chamber 180 is disconnected at quick release coupling 91 or if air cylinder 102 and buoyancy compensator 85 are both empty. If the emergency ascent was uncontrolled, and the diver forgot to deflate chamber 180, it would self destruct at rupture plug 182, releasing its entrapped air that had become pressurized because of the ascent. At that point the ascent rate would slow allowing the diver to regain control, further slowing his ascent rate to within the recommended rate of 20 to 30 feet per minute, rather than the ascent rates of 200 to 300 feet per minute, generated during an emergency buoyant ascent. If the diver should snag a fish hook in their primary chamber 85, then the horse collar vest stored in the shoulder straps would provide a redundant personal safety vest. In the event that the diver needed to ditch the dive gear, the power inflated forward horse collar safety vest can be quickly disconnected by quick release coupling 91. Alternatively, the horse collar can be separated and extended to the diver's buddy who has suffered a failure of his single chambered buoyancy compensator. If the diver was snorkeling the horse collar safety vest could be disconnected and inflated via oral inflator 84 and used independently from the remainder of the heads up safety vest.

FIG. 10 shows a diver 202 with a flap 106 which was used to enclose the flotation chamber 97 now shown in the open position. In front of flap 106 is the separating horse collar forward surface flotation chamber 97, inflated at the diver's waist. The forward chamber is retained by elastic webbing 104 that allows the chamber to expand away from the diver rather than constrict the diver's abdomen and therefore breathing. Quick release buckle 104 allows the diver to separate the forward bladder which can then be disconnected via quick release coupler 91. Once the flotation chamber 97 is free it can be used as a rescue float for approaching a hypoxic diver, held aloft as a distress marker, left floating at the surface to warn boat traffic of diver activity, used underwater as a bottom marker in search and rescue activities, or used as a small salvage device. For rapid emergency inflation the product can be stored in a pocket and connected to the air hose. Chamber 97 as it is currently shown is retained by strap 104 providing the central point of buoyancy that contributes to the heads up surface position. Though not required, the diver can be provided with quick release shoulder trim weights 174, retained by hook and loop fastener 173 and 175. The diver by pulling on D-ring 172 peels open the pocket and lead shot filled container 174 can fall away from the diver. The trim weights are exactly opposite the site of underwater buoyancy contained in the

EXHIBIT C
Page 47 of 67 pages

US 6,558,082 B1

25

buoyancy compensator and helps the diver achieve an ideal balanced underwater and surface position. The diver 202 is also shown carrying an alternate forward or flotation chamber 96 which can be substituted for chamber 97 and secured to the diver by elastic retaining strap 104 which passes through strap eyelets 110 mounted on the edges of bladder 96. This larger float has all the same functions of the horse collar forward chamber 97 with the addition that it can be used as a transport raft for a disabled diver or act as a surf mat at the end of the dive for swimming back to shore.

FIG. 12 illustrates a composite of several of the disclosed inventions. The multi-chambered heads up safety vest modified for use by the scuba diver by inclusion of tank bands 109 which attach the tank 102 to a fully inflated adjustable buoyancy compensator 85. The tank bands 109 are longer than those currently located on buoyancy compensators in the marketplace. The extra length in tank band 109 is needed to allow the diver to thread on the tank compensating keel weight 100. The keel weight 100 can be located on the top, bottom, or on both tank bands 109 as needed. A diver in a bathing suit needs to locate the keel weight on the lower band. A diver wearing a buoyant thermal protective suit requiring a weight belt can shift the keel weight to the top tank band 109 to establish the ideal surface position. Cam buckle 101 is located off the side of the tank 102 so that the back side of the tank is available for placement of the keel weight 100. Over pressure relief valve 111 is located opposite the buoyancy compensator power inflator 87 allowing the two to be interchanged. The beginner is accustomed to the power inflator 87 coming over the shoulder but when located in this position power inflator 87 floats free and is often hard to locate underwater. When the power inflator 87 is mounted on the front of the buoyancy compensator chamber 85 it hangs straight down between the diver and the tank and is easily located when needed. The multi-function rescue product and raft 207 is located between the diver 202 and the tank 102. Lanyard 211 wraps around rescue product 207 allowing the diver to remove the rescue product 207 for use without having to remove any other dive gear. A generic forward chamber 105 is inflated and retained by elastic strap 104. The flap 106 includes a variable fabric valve comprised of hook and loop fasteners 171 that variably regulates the use of the forward chamber 105. Reducer hooks strip 107 decreases the amount of interactive surface in the fabric valve allowing the diver 202 to vary the operation of the fabric valve from automatic to semi-automatic, to manual. With the reducer strip in place the air pressure from the rear chamber is capable of forcing open the valve deploying the forward chamber without the diver needing to do anything. In the semi-automatic mode, the diver 202 partially removes the reducer strip 107, now the fabric valve 171 will swell because of the mounting air pressure, after a period of time flap 106 will eventually open. As the diver becomes more skilled and capable of operating the fabric valve 171 in flap 106 in the manual mode, he will totally remove the reducer strip 107. With no reducer strip 107 in place the strength of the fabric valve 171 exceeds the 2.5 psi over pressure relief valve 111 on the rear chamber or the small bore over pressure relief valve built into the oral inflator 193. On a rapid ascent from significant depths, pressure will build up at such a fast rate that the small bore oral inflator over pressure relief valve 193 cannot keep up and the forward chamber will rupture, protecting the diver from any further acceleration and will contribute to the diver's deceleration by removing the buoyancy contributed by the forward chamber. With no reducer strip 107 in place the high lift surface flotation device is safely locked away while the diver

26

is underwater, reducing the amount of lift attached to the diver's body that entraps air or could be inflated by panic or mechanical failure of the power inflator 87. Waist band buckle 178 is attached to hook and loop base 179 that allows the diver to quickly and reliably shift the position of the waist band buckle 178 to adapt the product to different divers or the same diver with different thermal protective gear.

FIG. 13 illustrates one way that an adjustable buoyancy compensator 85 can be assembled from the front. The body of the buoyancy compensator 85 is covered with loop fastener 131. The inside edge of the side chamber forms a flap 138 which has loop fastener 137 on the front side and hook fastener 132 on the back side. As the chamber is rolled up the hook and loop adhere along the inside edge and clip 196 locks the outer edge from unwinding under pressure from the air contained in the buoyancy compensator. The adjustable buoyancy compensator 85 gives the diver the ability to further reduce the amount of lift attached to his body to the absolute minimum needed for each dive profile and dive environment. Reducing unnecessary risk of rapid ascent, embolism and the bends.

FIG. 14 shows an alternate way to reduce the volume of a chamber using hook straps 151 and loops traps 150. As the chamber is rolled up to the desired amount of lift as indicated on indicator gauge 133, straps 150 and 151 are fastened. The side chambers are attached to the loop body of the buoyancy compensator by way of hook strap 152. Hook flap 161 closes loop pouch 160 that contains lead shot to neutralize the inherent buoyancy of the buoyancy compensator 85 so that ballast is not consolidated onto the weight belt. Keel weight 100 is shown on the top tank band 109. There are many ways that the chambers could be secured after being reduced in volume such as by buttons, snaps, zippers, pins, constricting bands, fabric flaps and fabric valves. The final result is that the diver can vary the volume of their buoyancy compensation chamber as required for a safe dive.

The side chambers 136 can be rolled to any point as indicated by the demands of the particular dive. Double sided velcro loop 150 connects with double sided hook 151. A piece of double sided velcro hook 152 attaches to the loop body of the buoyancy compensator. The cam buckle 101 of tank band 109 generates the pressure between the buoyancy compensator and the tank and secures the hook strap 152 from peeling off. In an emergency at the surface the reduced volume can be accessed by releasing the velcro valve straps 150 and 151. It is noted that the chamber behind the neck 134 is not accessible to being reduced.

SUMMARY OF THE INVENTION

Accordingly, the correct positioning of a very small amount of buoyancy can accomplish what five to ten times that same amount of buoyancy cannot, a single heads up righting moment that will protect the airway. After surviving the initial entry into the water, signaling search and rescue efforts can make the difference between life and death. Dual tragedy is the term applied to the death of the rescuer by a hypoxic victim, an inflatable float is one of the safest ways to approach a floundering victim. It can take hours for available life rafts to round up survivors, often victims who have survived the initial insult of entry perish within thirty minutes of hypothermia. The only solution to hypothermia is to remove the victim from the water whether they are waiting to be picked up by the life raft of it they are going to be spending an extended period at sea until land based

EXHIBIT
Page 44 of 103 pages

search and rescue efforts arrive. The multi-function rescue product and raft comprised of a multiplicity of chambers, constructed from the appropriate material, can be built into the heads up safety vest where it is safely stored until needed.

The principles of a heads up safety vest need to be modified for use underwater by separating out high lift surface flotation, incorporating a variable volume buoyancy compensation chamber that can be reduced to the lowest volume necessary for a particular set of dive gear and dive environment. The current invention makes great strides in reducing the emergency ascent rate and thus reducing the exposure to pulmonary barotrauma, arterial gas embolism as well as the chances of developing decompression sickness. The buoyancy of some air cylinders when empty and the use of a primary back mounted buoyancy compensator, require the addition of a tank compensating keel weight to assure the diver that with or without the deployment of the forward chamber that once the diver is at the surface, that their only inflatable product will roll them over and place their airway out of the water if they are unable to do so themselves. A third self rupturing emergency buoyant ascent chamber can be an option if the diver insists on using an underwater propulsion device. The incorporation of numerous rescue devices as integrated chambers in fluid communication with the power inflated dedicated buoyancy compensator, allows the user rapid access to rescue boards, distress markers, transport rafts, dive site markers, underwater markers, salvage devices, tender crafts and surf mater. This wide range of power inflatable products confers significant advances in water safety, survival and enjoyment.

FIGS. 15 through 25 illustrate a first alternative embodiment for a counterweight assembly 300 which generally includes a weight member 302 and means for attaching weight member 302 to assure reliable and consistent heads up position of the person at surface level. A first means for attaching weight member 302 embodiment includes a pair of vertical slots 304 and 306 defined by weight member 302 and a tank band or strap 320 which includes a first end 322 and a second end 324. A tank band connection member can be provided at first end 322 of tank band 320. Preferably, the connection member is a tensioning device such as a conventional cam buckle 330, however, such is not limiting and other attachment mechanisms, such as D-rings, hook and loop fasteners, magnets, suction cup devices, etc., are considered within the scope of the invention.

To properly attach weight member 302 to air tank 301 second end 324 is inserted through vertical slots 304 and 306, weight member 302 is properly positioned with respect to air tank 301 and tank band 320 is tightly wrapped around air tank 301 with weight member 302 properly positioned. Cam buckle 330 provides for attachment of second end 324 with first end 322 to maintain weight member 302 in proper position along tank 301. Weight member 302 is preferably secured such that the diver or user cannot remove or release weight member 302 during his or her underwater travels. This guarantees reliable and consistent heads up positioning of the diver at the water surface level in the event the diver becomes incapacitated.

A non-skid means can be provided to prevent weight member 302 from moving out of position with respect to tank 301. Preferably, the non-skid means is a non-compressible rubber or plastic member 328 sewn to the inside surface of tank band 320, however, other conventional nonskid means can be provided and are considered within the scope of the invention.

As seen in FIGS. 26 and 27, one or more suction cups 380 can be mechanically fastened into weight member 302 by

conventional means. Alternatively, a sheet of suction cups (not shown) can be glued or molded into weight member 302. The sheet of suction cups is provided to cover a majority of the interior surface of counterweight 300. The sheet of suction cups is provided with apertures which are shaped and aligned with vertical slots 304 and 306 and horizontal slots 314 and 316, described in detail below, so not to interfere with the insertion of tank band 320 or coupling strap 340, also described in detail below, through slots 304 and 306 or 314 and 316, respectively.

In either suction cup embodiment, the suction cups are provided to provide a quick attachment of weight member 302, as well as a quick removal means for weight member 302. The suction cups are particularly useful during training or practices where the exact amount of ballast for the diver or person is uncertain and various weight members 302 of differing weights are to be attached and detached from cylinder 301 until the proper amount of ballast (weight) required for the specific individual is determined. Without the suction cups, the trainer or person determining the proper amount of ballast (weight), has to repeatedly attach and detach various weight members 302 via straps 320 or 340 as described above, which is very time consuming. The use of suction cups provide a quick and accurate method for readily determining a proper weight member 302 for the individual. Additionally, the suction cups are also useful for maintaining weight member 302 in proper position, while weight member 302 is properly secured by either tank band 320 or coupling strap 340 in conjunction with strap 360 of buoyancy compensator 359.

Alternatively, a hook and loop/pin/snap system along the tank's longitudinal axis would allow rapid determination of size and location by a dive master/instructor. Thus, a multitude of known attachment devices could be incorporated and utilized by a second person assisting the user for determining the proper size and location of the weight member for the specific user.

An alternative means for attaching weight member 302 embodiment includes a pair of horizontal slots 314 and 316 and a relatively small coupling strap 340 for joining weight member 302 to a conventional buoyancy compensator strap 360 which is provided for conventionally attaching air cylinder 301 to a conventional buoyancy compensator 359.

Coupling strap 340 includes a first end 342, a second end 344, an outer surface 346 and an inner surface 348. Preferably, hook and loop fastening means 350 and 352 are provided on inner surface 348 at first end 342 and second end 344, respectively. However, other conventional attachment means, though not preferred, can also be utilized and are considered within the scope of the invention. Coupling strap 340 can also be provided with a pull strap 354 at first end 342.

To properly attach weight member 302, cylinder or tank 301 is initially conventionally loosely attached to buoyancy compensator 359 in conjunction with strap 360 which utilizes a conventional cam buckle for its connection means. Once cylinder 301 is loosely attached to buoyancy compensator 359, first end 342 of coupling strap 340 is inserted between strap 360 and cylinder 301. Second end 344 of coupling strap 340 is inserted through horizontal slot 314 or 316 from behind weight member 302 and then back through the other horizontal slot 316 or 314, respectively, for attachment to first end 342 by mating of hook and loop fastening means 350 and 352. Strap 360, having weight member 302 attached thereto, is tightened around cylinder 301 in conjunction with its cam buckle as is conventionally known, to

EXHIBIT
Page 82 of 62 pages

securely attaching cylinder 301 to buoyancy compensator 359. It is to be understood that the roles of ends 342 and 344 can be reversed with second end 344 being inserted through and between strap 360 and cylinder 301 and first end 342 being inserted through horizontal slots 314 and 316 for mating with second end 344.

Prior to tightening strap 360, weight member 302 is properly positioned with respect to cylinder 301 and preferably, the mating of first end 342 to second end 344 is positioned between buoyancy compensator strap 360 and cylinder 301. This attachment position prevents inadvertent detachment of ends 342 and 344 from each other, once strap 360 is properly tightened, thus, assuring that weight member 302 will remain properly secured.

A slight recess 319 on the interior aspect of weight member 302 is preferably provided when attaching weight member 302 by a coupling strap 340. As the cam buckle generates tension in the buoyancy compensator strap 360, the tension also pulls on coupling strap 340. This pulling on coupling strap 340, tightens the attachment of weight member 302 to strap 360. The secured and tightened strap 360 compresses the hook and loop attachment of ends 342 and 344, thus, preventing accidental release. The point where ends 342 and 344 are positioned between strap 360 and cylinder 301 protrudes outward slightly which is received within recess 319 of weight member 302, when weight member 302 is properly secured. Thus, recess 319 helps couple weight member 302 specifically to the exact shape of each tank or cylinder 301 so that there is no opening to ensnare objects underwater.

When removing weight member 302, strap 360 is loosened by conventional means, and tab 354 is pulled to break the attachment of ends 342 and 344 to each other, which allows weight member 302 to be removed. However, it is important to note, that weight member 302 is preferably secured such that the diver or user cannot remove or release weight member 302 during his or her underwater travels. This guarantees reliable and consistent heads up positioning of the diver at the water surface level in the event the diver becomes incapacitated.

The threading of the cam buckle, in conjunction with strap 360, is a complicated process. Thus, by providing slots 314 and 316 and coupling strap 340, weight member 302 can be removed without having to re-thread the cam buckle.

Preferably, buoyancy compensator strap 360, similar to tank band 320, is provided with a non-skid means to prevent tank 301 from moving out of position with respect to its attachment by strap 360 and assuring that weight member 302 remains properly placed with respect to tank 301. Also like tank band 320, in the preferred embodiment, the non-skid means is a non-compressible rubber or plastic member 363 sewn to the inside surface of strap 360.

Preferably, the radius of weight member 302 is the same as the cylinder or tank 301 to which it is attached to prevent snagging of various underwater objects, such as fishing lines, when a diver, having a tank 301 and counterweight assembly 300 attached to his or her buoyancy compensator, is moving underwater. Accordingly, weight member 302 is preferably configured specifically to tank 301's circumference and is provided with a feathered edge (rounded/tapered leading edge) to eliminate any gaps which might snag kelp.

Though the various counterweight assembly described above and below are discussed in conjunction with a buoyancy compensator, it should be understood that the counterweight assemblies can also be utilized with personal flotation devices such as life jackets and life vests. Thus, where

reference is made to a buoyancy compensator throughout the application, it is also intended to include other personal flotation devices such as the life jackets and life vests.

Weight member 302 can be provided with a soft coating to also prevent weight member 302 from sliding when properly attached, as well as increasing the adherence of weight member 302 and buoyancy compensator 359 to cylinder 301. The soft outer coating of weight member 302 also protects cylinder 301's protective and cosmetic coating from being scratched.

Weight member 302 is provided with a relatively thin flat profile which increases the total surface area between weight member 302 and cylinder 301 and increases the security of the attachment of buoyancy compensator 359 to cylinder 301. The lower profile is designed to provide less drag and less chance of snagging underwater objects such as kelp. Weight member 302 can be provided with a feathered edge to couple specifically to the exact shape of each tank or cylinder 301 so that there is no opening to ensnare objects underwater.

Preferably, weight member 302 can weigh approximately six (6 lbs) pounds. However, this weight amount is not limiting, and other weight amounts for weight member 302 can be utilized, as determined by a particular diver's needs, and are considered within the scope of the invention.

FIGS. 28 through 30 illustrate a second alternative embodiment counterweight assembly generally designated as reference numeral 400. Counterweight assembly 400 can either be utilized with conventional buoyancy compensator strap 360 or can be utilized in conjunction with a tank strap or band 420, which is similar to tank band 320. Counterweight assembly 400 consists of a flexible pouch member 430 and one or more weight members 460. Pouch member 430 is preferably constructed from a fabric material, and can be either slidably and removably attached or permanently attached to either tank band 420 or buoyancy compensator strap 360.

When removably attaching pouch member 430 to either tank band 420 or strap 360, a loop member 434 is preferably attached to the back of pouch member 430, by conventional means such as stitching, and either tank band 420 or strap 360 is inserted through loop member 434 until pouch member is properly positioned with respect to cylinder 301. Where strap 360 is utilized, pouch member 430 is preferably properly positioned prior to final tightening of strap 360 around cylinder 301.

Alternatively, two loop portions (not shown) can be provided each being attached at their respective first ends to pouch member 430 by conventional means such as stitching. The second outer ends of the loop portions can respectively be provided with attachment means such as hook and loop fasteners. When removably attaching pouch member 430 to strap 360 or tank band 420, the outer ends of the loop portions being disposed between strap 360 or tank band 420 and cylinder 301, where the loop portion outer ends mate to define a loop member. Once the outer ends are mating and properly positioned, strap 360 or tank band 420 is properly tightened sandwiching the outer ends between cylinder 301 and strap 360 or tank band 420 to prevent inadvertent releasing of the outer ends, as well as assuring proper positioning of pouch member 430.

When permanent attachment of pouch member 430 is desired, such attachment is preferably accomplished by conventional means such as stitching or sewing (FIG. 29). Preferably, the permanent attachment of pouch member 430 to tank band 420 or strap 360 is such that pouch member 430 is properly positioned when tank band 420 or strap 360 is tightened.

EXHIBIT 4
Page 50 of 114 pages

US 6,558,082 B1

31

Pouch member 430 can be provided with a plurality of individual weight receiving pockets 432. Preferably, four (4) to eight (8) individual pockets 432 are provided. However, this number of pockets 432 is not limiting, and other pocket 432 amounts can be provided and are considered within the scope of the invention. Alternatively, pouch member 430 can be provided with large weight receiving area.

Individual weights 460, which act as ballast members, can be inserted into one or more of pockets 432 or into the large weight receiving area, depending on the amount of weight required. Alternatively one large hard weight (i.e. lead, steel etc.) or soft weight (i.e. sand, loose ballast, etc.) can be provided in the large weight receiving area. Weight members 460 are preferably constructed from lead, though other materials can be utilized and are considered within the scope of the invention.

The use of one or more weight members 460 allows for fine tuning of the amount of weight necessary for reliable heads up positioning at water surface level of an incapacitated diver, taking into consideration the diver's weight, equipment, etc. Thus, the exact amount of weight or ballast can be provided to assure that the user's airway will be protected in the event of an emergency.

A flap member 440 can be attached to pouch member 430 by conventional means such as sewing or stitching. In use, flap member is folded over and attached to pouch member 430 preferably by conventional means such as by the mating of hook and loop fasteners 435 and 437 disposed on at least a portion of an inner surface of flap member 440 and on at least a back outer surface of pouch member 430. However, other attachment means can be provided such as snaps, buttons, zippers, etc., and are considered within the scope of the invention. Flap member 440 prevents weight members 460 from inadvertently being removed from their placement within pocket member 432 or the large weight receiving area. Thus, when counterweight assembly is properly positioned, flap member 440 is compressed, to guarantee it remains in its closed position, by tank strap 420 or strap 360. Flap member 440 can be provided with a non-skid member 441, similar to the non-skid members discussed above.

Additionally, in lieu of inserting weight members 460 across in a horizontal manner, pouch member 430 can be constructed such that the weight members are inserted within pouch member 430 in a vertical fashion. Preferably, each individual weight member 460 weighs approximately two (2 lbs) pounds, though such is not limiting and other weight amounts can be utilized and are considered within the scope of the invention. Furthermore, weight members 460 can be symmetrical, however, such is also not limiting.

Pouch member 430 can be constructed from neoprene, spandex, canvas, nylon, or other conventional soft and flexible fabric materials. Furthermore, elastic or other stretch means can be incorporated into pouch member, to assure a tight and snug fit of one or more weight members 460 within pouch member.

In this embodiment, pouch member 430 is preferably secured such that the diver or user cannot remove or release weight member(s) 460 during his or her underwater travels. This guarantees reliable and consistent heads up positioning of the diver at the water surface level in the event the diver becomes incapacitated. This feature of not allowing the diver or user from having access to the weight members during his or her underwater travels is found in all of the tank mounted counterweight assemblies of the present invention, described above or below.

As seen in FIGS. 32 and 33, one or more individual weights 500 can be attached directly to conventional buoy-

32

ancy compensator strap 360 or to tank band 320. In this counterweight assembly embodiment, weight members 500 are provided with a slot 502 for insertion therethrough of either strap 360 or tank band 320. Similar to above, a non-skid means (not shown) can also be provided on either strap 320 or 360 or weight members 500 to prevent weight members 500 from moving out of proper position. Also similar to above, the number of weight members 500 provided is dependent on several factors such as diver's weight, equipment weight, etc. Weight members 500 are preferably constructed from lead or steel, though other materials can be utilized and are considered within the scope of the invention. Weight members 500 preferably weigh between one (1 lb) pound to three (3 lbs) pounds each. However, this weight amount is not limiting, and other weight amounts for weight members 500 can be utilized and are considered within the scope of the invention.

As seen in FIGS. 34 through 36, a weighted sleeve member 600 can be positioned along tank or cylinder 301 to provide ballast in order to assure heads up positioning at water surface level of an incapacitated diver. Weighted sleeve member 600 is tightly slid along cylinder 301 to its proper position with respect to cylinder 301. Weighted sleeve member may be fastened by conventional means such as bolting.

A flexible pouch member 620, similar to the various embodiments pouch member of described above and below, can also be provided in addition to weighted sleeve member 600. Pouch member 620 can be provided with one or more weight 630 receiving pockets 632. Pouch member 620 is preferably constructed from a fabric material and can include a flap member (not shown). Pouch member 620 is preferably disposed around sleeve member 600 and can be attached by conventional means such as hook and loop fastening members 622 or by buckle means. Thus, weighted sleeve member 600 can have a non-user releasable connection securing an additional counterweight assembly to weighted sleeve member 600. Furthermore, weighted sleeve member 600 can be positioned at the bottom of tank 301 for use in warm water.

Alternatively, a pouch member 650 (FIG. 36), can be provided which is constructed from a rigid material, such as plastic and is preferably constructed integral with sleeve member 600. Pouch member 650 can be provided with one or more weight 630 receiving pockets 652. Rigid receiving pockets 652 can be provided with holes in their bottom to push weight members 630 out after the dive. As receiving pockets 652 are constructed from a rigid material, preferably, the weight members to be inserted within, should correspond in shape to pockets 652. Furthermore, conventional cap means is preferably provided for each pocket 652 to prevent the weight members from falling out during the dive. Pouch member 620 or 650 and sleeve member 600 function similar to the other embodiment pouch members of the present invention. The lateral edge of weight members 630 can be modified to allow it to easily slide into tracks (pockets 652) built into or formed integral with weighted sleeve member 600.

FIGS. 37 through 39 illustrate another counterweight assembly embodiment generally designated as reference numeral 700. Counterweight assembly 700 includes a pocket member 710 which can be either permanently or removably fixed to buoyancy compensator strap 360 or tank band 320, in any of the methods previously described above, and a hard weight member 780 or soft weight member 790 disposed within a pouch member 740 with pouch member 740 being at least partially disposed within pocket member

US 6,558,082 B1

33

710. Pouch member 740 is provided with a quick release handle 754 which is attached to pouch member 740 by a strap member 770 and allows a person, other than the user, to remove pouch member 740 and weight member 780 or 790 from pocket member 710 when a diver or other swimmer is finished with his or her underwater travels. Normally a person standing on a boat, dock or other type of surface, pulls off the diver's equipment (including his or her buoyancy compensator 359 and attached air tank 301) while the diver remains in the water.

This removal of equipment makes it easier for the diver to climb onto the boat or dock. Buoyancy compensator 359 and air tank 301 typically weigh together approximately fifty (50 lbs) pounds. With the use of certain buoyancy compensators currently available, an attached weight member 780 or 790 may add up to approximately eighteen (18) to twenty (20) additional pounds to the amount of weight the person in the boat has to remove. The person in the boat normally bends over towards the water in order to reach the diver who is in the water. This position, seriously exposes the person's back to strains and pulls, as well as potential hernias. Individuals who work on dive boats are constantly lifting the equipment onto the boat, in such awkward position, throughout the day. Accordingly, any reduction in the amount of weight to be lifted each time, becomes significant when such tasks are performed on numerous occasions during one outing or continuously throughout the day.

Thus, by providing a quick release means for weight members 780 or 790, the person in the boat can initially remove weight members 780 or 790, thus, reducing the weight of the buoyancy compensator and air tank to be lifted by approximately up to eighteen (18) to twenty (20) pounds. This reduction in weight could help to prevent many back problems commonly experienced by persons removing the diver's equipment onto the boat or dock.

FIG. 39 illustrates the various steps of removing quick release weight member 780 or 790 from pocket member 710 by the person on the boat or dock. As previously mentioned, it is to be understood that weight members 780 or 790, as well as all of the counterweight assembly embodiments of the present invention, are positioned such that the weight members cannot be removed or released by the diver in order to assure that the diver is consistently maintained in a heads up position in the event he or she becomes incapacitated.

Pocket member 710 is shown having an outer surface 712. A hook and loop fastening means 714 is provided on outer surface 712 adjacent an open end of pocket member 710. A pocket flap member 716 is provided having an outer surface 718 and an inner surface 720. A first flap hook and loop fastening means 722 is provided on outer surface 718 and a second hook and loop fastening means 724 is provided on inner surface 720. Pocket member 710 can be provided with a perforated portion.

Pouch member 740 houses removable weight member 780 or 790. The weight member can be a sandbag (soft weight 790), lead weight (hard weight 780), or other appropriate ballast member which can be disposed within pouch member 740. A hook and loop fastening means 772 is provided on a first surface of strap member 770 and hook and loop fastening means 776 and 778 are provided on a second surface of strap member 770. A first end of strap member 770 is attached to pouch member 740 and a second end of strap member 770 is attached to handle means 754 both by conventional means. Handle means 754 includes a triangularly shaped gripping member 756 having a gripping surface 758.

34

Weight members 780 or 790 act as ballast means to assure heads up positioning of an incapacitated diver at water surface level and in use are disposed within pouch member 740 which in turn is disposed within pocket member 710 with strap member 770 and handle means 454 protruding out of pocket member 710. A portion of hook and loop fastening means 724 mates with hook and loop fastening means 778, hook and loop fastening means 772 mates with a portion of hook and loop fastening means 714, and a remaining portion of hook and loop fastening means 724 mates with a remaining portion of hook and loop fastening means 714, by folding flap 716 inward along a fold line 717. At this point, strap 770 is folded inward over flap 716 to allow hook and loop fastening means 776 to mate with hook and loop fastening means 722 to securely retain weight member 780 or 790 within pocket member 710, to assure consistent heads up positioning of an incapacitated diver, while allowing a person standing on a boat or dock to remove weight member 780 or 790 when the diver is ready to climb onto the boat or dock.

To remove weight member 780 or 790, the person on the boat or dock grabs handle means 754 at gripping surface 758 and pulls handle means 754 with a normal, but strong, tugging motion force, which nearly simultaneously breaks the attachment of fastening means 776 to fastening means 722, fastening means 714 to fastening means 724, fastening means 772 to fastening means 714, and fastening means 778 to fastening means 724, to allow weight member 780 or 790 to be quickly removed from pocket member 710. Once removed, the person on the boat or dock, merely drops weight member 780 or 790 and pouch member 740, on the boat or dock, respectively, where it can be properly redispensed within pocket member 710, when the diver or another prepares to enter the water again.

As seen in FIGS. 40 and 41, a combination of the previously described weight members can also be provided. As shown, counterweight assembly 300 is provided with a counterweight assembly 700 attached thereto. Weight member 302 provides a certain amount of ballast (weight), while the amount of ballast (weight member 780 or 790) provided within pocket member 710 varies depending on the weight of the diver and his or her equipment. Though, pocket member 710 is shown removably attached to weight member 302, it is to be understood, that the other pouch members described above, as well as one or more individual weights 500, can also be utilized in combination with weight member 302, and such other combinations are also within the scope of the invention. Furthermore, other combinations of counterweight assembly 700, counterweight assembly 300, individual weights 500 and the other pouch members described above can be provided and are all considered within the scope of the present invention.

To attach pocket member 710, or the other pouch members, tank band 320 is inserted through one of the vertical slots 304 or 306 of weight member 302, through a loop member attached to the back of pocket member (the loop portions described above could also be utilized), through the other vertical slot 306 or 304, respectively, and then tightened by conventional means, such as D-rings members, buckle means, etc, as described above.

Where weight member 302 is attached with buoyancy compensator strap 360, if loop portions are provided, the loop portions can be inserted through horizontal slots 314 and 316 and attached to each other, in lieu of providing coupling strap 340. Thus, in this embodiment, the loop portions provide the mechanism for attaching both weight member 302 to cylinder 301 and pocket member 710 to weight member 302.

It should also be understood in some applications, more than one of the same type of weight member, described above, may be utilized. For example, a first weight member 302 could be attached relatively high with respect to cylinder 301 and a second weight member 302 could be attached relatively low with respect to cylinder 301.

Furthermore, the vertical positioning of any of the weight members described above can be easily adjusted between dives or possibly by a person, other than the diver, during the dive. The weight member and tank band 320 are infinitely adjustable along the length of the horizontal axis. The ability to move tank band 320 and the attached weight member up and down the tank allows for optimal position of the weight member. This in turn allows the angle of the hyperextension of the "distressed" diver's neck at the surface to be accurately adjusted for optimal airway comfort. Thus, tank band 320 can be quickly and securely adjusted to attach the appropriate weight member in the appropriate position in response to any specific set of dive gear or dive environment.

A warm water diver may be diving with a minimal weight belt (i.e. four (4) to ten (10) pounds). Some divers may feel that attaching six (6) pounds of non-releasable ballast to their air cylinder 301 would result in a significant reduction in the amount of releasable ballast at depth. In order to incorporate the critical ballast counterweight (weight member) while preserving the diver's current releasable weight, the diver can use an offsetting buoyant means, fixed or releasable. The diver that requires a four (4) pound counterweight (weight member) to provide reliable airway protection can add a four (4) pound buoyant pad to protect their tail bone from the tank, fill the space between the small of the back and their tank or use the buoyant material to pad the thorax or their head. The foam can be alternatively attached to the front of the buoyancy compensator where it can be released in the event of an uncontrolled emergency (i.e. ascent due to accidental loss of weight at depth as might occur if the weight belt is snagged). The foam on the front would also increase the strength of the face up righting moment at the surface as might be desired by the beginning diver.

It is notable that if the counterweight is large enough it will overcome all other righting moments. The larger the ballast the stronger the righting effect. The balance is that cylinder 301 is already heavy, at the point of barely manageable. The combination of the forward buoyant means and four (4) to eight (8) pounds of ballast in the counterweight keeps the total system light enough that it can be comfortably maneuvered. If the forward chamber is left at the surface to protect the diver from boat traffic then the counterweight must be approximately doubled to preserve the heads up safety feature. If the counterweight is large enough, it can act alone to right the diver. Its key requirement is that it be located exactly opposite the diver, easily adjusted to maintain that position. A securely attached counterweight can be used to retrofit existing buoyancy compensators, as long as they have an adherent element to assure that the counterweight will not slide from position.

The counterweight is critical in balancing out the entire set of dive gear so that in an emergency the diver's gear provides a single stabilized righting moment that places the distressed divers airway out of the water.

The counterweight embodiments described above (FIGS. 15 through 41) can be relatively easily incorporated into other products, such as any and all other life vests, life jackets, etc. Thus, the life jacket or other personal flotation

device (collectively referred to as "life jacket") can be provided with a ballast/weight member attached to the back of the jacket, which as a counterweight member to provide angular momentum in rolling the diver or other wearer over in the water, such that the diver floats face up in the water. Preferably, the counterweight is attached posterior central.

A conventional life vest/life jacket can be comprised of inherently buoyant material, such as (1) kapok, closed foam; (2) mixed inherently buoyant material and inflatable ("hybrid" personal flotation device"); and (3) purely inflatable design. All of these design of a lifesaving buoyant means are improved by the addition of the ballast/counterweight. Preferably, the counterweight is able to be varied in size and position depending on the other equipment worn by the user and the user's anatomy. Typically the counterweight is between three (3) and six (6) pounds and is securely attachable to the life jacket adjacent and between the neck and lower back area of the user.

Furthermore, a conventional air tank or cylinder can have a weight member constructed integral with the tank if the intended wearer knows the specific amount of counterweight he or she requires, and the exact location of the weight member with respect to the air tank.

Additionally, where steel tanks or cylinders are utilized, a weight member having magnet means associated there with can be provided for directly attaching the weight member to the tank. This use would only be for training purposes and/or for determining the proper amount of weight, as well as the proper location of the weight on the tank, for the specific individual. This attachment embodiment would not be used during normal dives and underwater travels, as there is a chance that the weight member may move or inadvertently fall off. However, the weight member could also be provided with a strap, to provide a second attachment means for the weight member, as well as providing a secure attachment.

The counterweight allows for the application of ballast mediated airway protection to enhance surface airway management and promote self sufficiency. The reliable protection of a distressed diver's airway depends on the ballast not changing position in any of the three axis (up, down or around cylinder). The instant invention achieves many critical features including providing that the weight be permanently attached, so that in an emergency it cannot be dropped. Since the weight member (counterweight) must be small enough to not compromise surface safety, it must be located on the back of the life jacket or on the back of the cylinder exactly opposite the diver where it generates the maximal rotational energy per pound of weight, rotational energy desperately needed to repeatedly turn the unconscious diver over onto their back against minor righting moments caused by limbs, variations in body density, and attached gear. In particular, if the victim is near heavy surf where the waves can flip a victim over onto their face, a strong heads up righting moment is essential. It should be understood that references to a "victim" include, but are not limited to, water accident victims and/or diving accident victims.

The counterweight assembly utilized is responsible for initiating the righting moment, and supplies the rotational energy needed to roll the victim over onto their back thereby assuring that the victim's face will be out of the water regardless of the angle of entry. Once the diver has reached the surface, the counterweight, in conjunction with the dynamics of a limp unconscious body, will oppose any tendency for the waves to roll the victim over into a face down position that would compromise the airway. In

EXHIBIT
Page 53 of 62 pages

summary, the counterweight assembly provides lateral stabilization of the water accident victim or diver (victim), and opposes rotational motion of the waves from over turning the victim into a face down position, but in the event that occurs, the counterweight assembly will automatically flip the victim back over onto their back, reestablishing the heads up orientation.

When an air cylinder is attached to the life vest or buoyancy compensator, the tank compensating counterweight becomes critical. If the victim is lying face down at the surface and goes limp, the counterweight will roll the diver over onto their back, stabilizing the diver's airway out of the water. The size of the weight member selected is in proportion to the type and size of life vest or size of buoyancy compensator and cylinder and whether the water is fresh or salt. The cylinder when empty is neutral to slightly negative, but lacks sufficient rotational energy to roll the victim over onto their back. The counterweight assembly in other words compensates for imbalances in the life vest, buoyancy compensator or the buoyancy shifts of the life vest or buoyancy compensator or the diver's air cylinder. If the cylinder remains negative when empty then the weight member can be smaller but still must generate sufficient angular momentum to offset the secondary righting moments generated by an imbalanced weight belt and attached gear or bladders. If the counterweight assembly is used as an adaptation to existing vest style buoyancy compensator, then it has to be strong enough to overcome the side righting movements generated by the common practice of using buoyancy under the arms.

Central to the weight member's design is that it be made of a very dense material such as lead, and be located exactly opposite the diver on the back side of the life vest or the tank. Traditionally the buckle that generates pressure on the belt that attaches the buoyancy compensator to the tank is located in the center at the back of the tank. Because the posterior central position is so critical for the performance of the counterweight assembly, the buckle has to be moved off center. This shift in the cam buckles location results in a slight inconvenience in terms of reduced access but is necessary to preserve the critical location and therefore the righting moment of the compensating counterweight assembly.

Drowned divers are often found with their weight belts still on. Usually the weights are located along the waist and the amount runs from a couple of pounds to more than forty pounds. As the amount of weight increases, the weight member needs to be located higher up the air cylinder to offset the placement of the weight belt. A dual tank band (providing two weight members) allows for a wide variation of weight placement.

The weight member can also be incorporated into the metal of the cylinder, adhered to the cylinder, enclosed in a covering of any sort, or even attached with magnetism. A pouch or cylinder can be used to contain lead shot or beach sand as long as it is non-releasable and ideally located along the longitudinal axis of the cylinder and thereby serves to generate the heads up righting moment, with the least amount of weight. The various weight member embodiments, described above, guarantee a single surface position every time. That surface position being heads up.

The inclusion of a couple of pounds of weight integrated into the tank band of the buoyancy compensator will allow the diver to overcome numerous minor righting moments that can place the airway of the exhausted or distressed diver under the water leading to drowning, the major cause of death in the sport of diving.

The various counterweight embodiments provide for ballast mediated airway protection, namely, the protection of the diver's airway at water surface level, particularly in an emergency when the diver is unable to protect his or her airway. The various present invention counterweight assemblies reduce the current problem of airway submersion which normally leads to shallow water drowning, the number one cause of recreational diver fatalities.

The attachment of the buoyancy compensator to the tank has always created problems. A cam buckle is provided at the end of the strap to generate tension in the strap. The strap which attaches the tank to the buoyancy compensator, stretches when wet, which can cause the tank to slide down if not out. Thus, the critical ballast compensating counterweight (weight member), in addition to rolling the distressed diver over to protect his or her airway, through increasing the surface area for attachment, serves to markedly improve the attachment of the buoyancy compensator to the tank.

Thus, the present invention illustrates the use or attachment of a relatively small, nonreleasable weight, which is applied to a variety of positions along the back of an air tank. The location at the back of the tank allows the size to be reduced to its minimum and still be able to provide reliable airway protection. In warm water the weight is provided relatively lower with respect to the air tank. In cold water where the diver has significant ballast already attached, the weight member is moved relatively higher with respect to the air cylinder towards the head to maintain optimal airway protection. The positioning of the weight member along the back of the tank, optimizes the angular momentum generated per unit of weight. The use of the smallest amount of weight possible to provide airway protection allows the warm water diver, who is by definition already using minimum weight.

With the use of a weight member as described above, from any position a distressed diver can be rolled over onto their back, repeatedly if necessary, with their neck hyper-extended and their airway positioned free and clear. The distressed diver is provided with ballast mediated airway protection which allows only a single, stable, surface position. Thus, when the diver cannot protect their airway, they can count on their counterweight assembly to act as a self rescue device providing emergency heads up surface flotation. Self rescue requires that at all times throughout the entire dive or underwater travel that the diver's gear is balanced such that their airway will not suddenly become vulnerable to submersion solely because they have become a couple of pounds out of balance in the last minutes of the dive or underwater travel due to the loss of air.

The above described counterweight assemblies roll the diver over, out of his or her side high airway submerging position and onto his or her back when the diver is unconscious. Accordingly, from any position the diver is rolled over onto their back, neck hyper-extended as it drops back, opening the airway. A diver in balance has a single stable airway protective righting moment, while a diver out of balance is susceptible to airway submersion and shallow water drowning.

By it's variable position, high or low, the above-described counterweight assemblies also assists in balancing all of the buoyancy and ballast attached to the diver, creating improved airway support for the distressed diver, from the beginning through the end of their dive or underwater adventure. Diver airway protection is provided regardless of whether the diver's gear is attached or dropped in part or in whole, as may occur in an emergency. The counterweight

EXHIBIT 11
Page 55 of 14 pages

assemblies are designed to compensate for loss ballast or shift in balance to extend airway protection throughout the dive or underwater travels. Even if the diver is originally face down and unconscious at the surface, the counterweight assembly, when properly positioned tends to almost immediately right the diver face up, thus, protecting the diver's airway should such diver lose consciousness on the surface.

Additionally, a variable displacement device can be provided for providing additional buoyancy to the diver and his or her gear to offset any excess ballast that must be attached to acquire airway protection through ballast mediated airway management as described above.

Some divers, in particular warm water tropical divers, may dive with very little ballast. On occasion, the diver requires a tank mounted ballast that exceeds the amount of ballast needed to submerge. Some reasons why this is required includes (1) diver anatomy (i.e. large "Barrel Chest"); (2) composition of the diver's cylinder (i.e. aluminum); (3) large displacement buoyancy compensator may require up to eighteen (18) to twenty (20) pounds of tank mounted counterweight to provided airway protection yet only require approximately seven (7) pounds to submerge while diving in a bathing suit in warm water; (4) diver wishes to retain the entire amount of releasable ballast so he or she can quickly acquire a net positive surface flotation by dropping his or her weight belt. In such situations the addition of buoyancy will allow the diver to retain his or her releasable weight belt while acquiring the ability to self rescue, as described above, i.e. protect his or her airway from submersion if the diver becomes unconscious. Preferably, the buoyancy added is non-compressible which can occur through the use of a rigid container built into the diver's buoyancy compensator back pack. Thus, the buoyancy means is attached to the diver/gear to offset the required airway protective tank mounted ballast (weight member). Preferably, the buoyant means is a rigid, non-compressible means for the provision of a specific amount of buoyancy, such as a non-compressible foam with permanent flotation qualities or fixed buoyancy bladder with adjustment inner valve for custom sizing to diver's buoyancy needs. Other alternative embodiment include a closed cell foam. However, with the use of a closed cell foam, as the diver submerges the bubbles in the foam compress, thus, reducing the buoyancy and requiring air to be added to the diver's buoyancy compensator jacket. The added air needs to be vented on ascent.

The buoyancy means preferably has a variable volume to allow for volume adjustments specific to the diver/dive environment. Additionally a single or multiple buoyant means can be provided and arranged to enhance surface flotation attitude.

As seen in FIG. 44, a training device for a tank mounted counter weight member is shown and generally references as device 800. A dive instructor during training, such as pool training, needs to individualize the size and location of the tank mounted counter weight member for each student (diver). To facilitate this time consuming process a longitudinal attachment means 800 is affixed to tank 301 with a quick release coupling means, such as quick side release buckles 802, thus, allowing for rapid attachment and adjustment of size and position of weight member(s) 820 which are housed in sleeve members. Hook and loop fastening means is disposed on at least a portion of the outer surface of the sleeve members for mating with hook and loop fastening strips 804 and 806 associated with training device 800.

The very security that is demanded of the tank mounted counter weight member when used as a life saving means

complicates its rapid change and adjustment. As a pool training aid, speed of adjustments is more important than security. As such, training device 800 can be preferably clearly marked with a warning label stating that the device is not to be used for diving.

The vertical tank mounted attachment means can be secured by a wide variety of mechanical means, including, magnetic, zippers, snaps, spring loaded pins, hook and loop fasteners, etc. For example, a fabric jacket having a strip of hook and loop fastening means attached along its length can be provided. Weights in specific sizes can be quickly affixed in combination to establish the correct size, then adjusted vertically to optimize the exact surface flotation position for hyperextension of the diver's neck. The weights are not limited to any specific, but preferably approximately one (1) or two (2) pounds each.

Training device 800 can be preferably provided with a vertical index 810 which identifies location, such as a measurement means from the bottom of tank 301. Thus, the instructor can inform the student of the exact location where the weight member should be attached to tank 301, as well as the exact amount of weight required at such location.

The fabric jacket can also be secured by a wide variety of means. Preferably, hook and loop fastening means is provided to allow the jacket to be easily attached to a wide variety of cylinder diameters. One or more adjustable locking belts can be provided for use with large tank mounted counter weights, which may be required with certain technical buoyancy compensators. The jacket may also be secured by a variety of other means such as belts, buckles, zippers, snaps, etc. Furthermore, the inside coating of the fabric is preferably of a high coefficient of friction to reduce any tendency of the jacket to slip or slide from proper position during adjustment and testing of various tank mounted counter weight member.

FIGS. 45 and 46 illustrate a quick disconnect connector embodiment generally designated as connector 900. Connector 900 generally includes a male member 910 associated with a lifting device 902 and a female member 930 commonly associated with an inflating hose member of a conventional buoyancy compensator (not shown). Typically, lifting device 902 is deployed at depth. Lifting device 902 can be any type of device which contains a flotation chamber, including, raft 96 shown in FIG. 10. When raft 96 is the intended lifting device, male member 910 replaces a conventional male member 192 (FIG. 10) and which is shown in greater detail as conventional male member 980 (FIG. 47).

With the use of a conventional connector (FIG. 47), male member 980 is provided with a groove member 982 for a locking attachment with female member 930, when the intended lifting device is to be inflated (i.e. emergency situation). Once male member 980 is properly connected to female member 930, an activating member 984 presses a Schrader valve 932 disposed within an internal passageway 934 which extends through female member 930 from its first end 936 to its second end 938. The activation of Schrader valve 932 allows air to flow into the flotation chamber of the lifting device for inflation purposes.

However, with the connection of male member 980 to female member 930, the user (diver) is also attached to the lifting device. Under pressure it is often difficult to release male member 980 from its locking attachment to female member 930. Thus, as the lifting device begins to ascent, the diver (user) is placed in a position of uncontrolled ascent, possibly, leading the diver to one or more of the dangerous conditions described above.

As seen in FIGS. 45 and 46, male member 980 is replaced with a male member 910. Male member 910 includes a first end 912, a second end 914 and an internal passageway 916 extending through said male member 910 from first end 912 to second end 914. Male member is not provided with a groove member to avoid the locking problems described in the previous paragraph. Male member 910 can also be provided with an outer circular flange member 918 and a Schrader valve activating bridge member 920.

In use, male member 910 is received within internal passageway 934 of female member 930 until flange member 918 abuts an outer first end 936 of female member. Thus, flange member 918 acts as a stop means to properly position the first end of male member 910 within internal passageway 934 of female member 930. This positioning of male member 910 with respect to female member 930 allows bridge member 920 to activate Schrader valve 932 to allow air to flow within a flotation chamber of lifting device 940.

Male member 910 is slightly smaller in outer diameter as compared to the inner diameter of internal passageway 934. This allows male member 910 to be snugly and tightly received and maintained within internal passageway 934 of female member 930, while at the same quickly and easily releasable. Lastly, outer flange member 918 also serves as a gripping means to quickly remove male member 910 from within internal passageway 934 of female member 930 once the flotation chamber of lifting device 902 is properly inflated or in the event of an emergency.

FIGS. 53 through 60 illustrate swing keel embodiments for a ballasted personal flotation device ("BPDF") which allows the use of a relatively small (light) keel (weight/ballast) to enhance comfort and compliance of a personal flotation device ("PFD") while retaining the efficacy necessary to self rescue a unconscious victim. PFD is defined, for all of the above and below disclosure, to include all various traditional personal flotation devices, as well as buoyancy compensators, and other types of dive gear. While permanent eccentric placement of the ballasting member achieves enhanced rotation, it leaves the victim floating off to one side, placing one corner of the mouth in closer proximity to the waters surface i.e. decreasing freeboard, a parameter used by testing laboratories to determine PFD efficacy. The placement of the mobile ballasting moment 1a on a centrally attached flexible 2a or rigid arm 11a allows movement of the keeling member towards either the left or right side. Once set in motion the keeling moment gains momentum, accelerating the victim about their axis of rotation, towards the position of greatest stability i.e. where the ballasting moment is suspended beneath the center of buoyancy rather than balanced above it and the victim's airway is consequently positioned out of the water.

The keel's arm can either be flexible 2a or rigid 11a. The swing of the keel is preferably constrained such that its course allows access to the left or right about a caudal arc but restricted in its cephalic swing such that the ballasting member cannot strike the victim's head. The location of attachment 6a of the keel's arm can be variable as dictated by location of the PFD's buoyant members or the individual's anatomy, i.e. such as one who has had a lung or limb removed with its dramatic impact on surface positioning. In general a central positioning provides the greatest symmetric freeboard. The keel's range can be limited by rigid 13a or flexible 5a member that constrains range of motion but ideally without impinging upon the ballasting member in such away that it would impair freedom of movement. A rigid cover 13a is preferred in protecting the head of the victim from being struck by the keel and provides reliable

constraints upon the lateral and posterior range of motion. To reduce cost, a fabric cover 5a sewn above the keel arm 2a can alternatively be provided and determines the keel's lateral and posterior range of motion.

To enhance mobility of the keel a spherical design 1a promotes easy rotation about its arc, though other shapes are considered within the scope of the invention. Comfort, aesthetics and therefore compliance argue for a portion of the keeling member to be more cylindrical 14a to reduce the protuberance of the keel from the back of the PFD.

A swivel 3a integrated into the flexible arm 2a or rigid arm 11a of the swing keel can be provided to reduce resistance of the ballasting member rolling along its arc. Swivel 3a eliminates the opposition to rotation that can arise from twisting the rigid or flexible arm that attaches the keel to the BPDF and/or eliminates the drag that can arise as the keel is skidded or dragged along the surface rather than rolled.

Modification of the dorsal surface of the PFD into a complementary convexity 4a further reduces the incidence of the center of ballast to be stabilized above the center of buoyancy. While the foam of the jacket could be shaped into a convex surface 4a to meet this need, the storage of the BPDF might result in the high density keel deforming the foam, creating a depression with significant memory such that when the PFD is pressed into use the depression might entrap the keel allowing the victim to once again be stabilized in a face down position. Ideally convexity 4a is formed of some rigid material. The rigid surface can be independent or fused to the PFD's closed cell foam. Rigid convex surface 4a further reduces the coefficient of friction between rolling swing keel 1a and the surface of the PFD over which the keel is rolling. The improved ease of movement of the rigid keel upon the rigid convexity further contributes to the reduction in keel mass without sacrificing reliable airway protection.

A rigid container 20a can alternatively contain the ballasting member, to be freed from the constraints of the flexible or rigid arm. Fully enclosed the ballast sphere 1a could roll across a surface designed to enhance self-rescue. In the face down position the keel preferably resides on a rigid convexity 4a initiating movement to the left or right lateral gully the lowest point to the left or right upon face down entry into the water. Upon reaching the lateral gully of the container the surface would angle off towards the legs or Caudal gully 22a. This inferior movement of the mobile ballast 1a complements the naturally occurring motion of the victim where the initial axial rotation is supplanted by a pendular motion as the legs swing from the flexed position of the face down position into the extended position of a victim floating face up. The containers third low point, the posterior gully 23a would attract the mobile keel from either the left or right caudal gully 22a, moving the ballast away from the back of the victim, establishing then stabilizing the victim in the safe zone, approximately thirty (30°) degree off of dead vertical. The dangerous zone is identified as vertical to less than approximately twenty (20°) degrees off of vertical, in which position the head of the unconscious victim can flex forward submerging the victim's face and/or seriously compromising the victim's airway. The rigid container 13a provides a three-dimensional rigid surface upon which the keel can easily relocate, directing the mobile ballast 1a through a progressive series of angled surfaces complementing and thereby driving the complex maneuvers associated first with initiation of rotation then converting the victim's rotary motion into a cephalo-pedal swing and finally stabilizing the unconscious victim in the airway protected surface position known as the "safe zone".

EXHIBIT 17
Page 91 of 111 pages

US 6,558,082 B1

43

The container if sealed **24a** can contribute an inflatable element equal to its displacement minus the mass of the keel, to the buoyant means of the PFD. The "neutral" buoyant mobile ballast "swing" keel can thus be integrated into the body of the PFD, reducing bulk and thereby enhancing comfort appearance and therefore supporting the compliance critical to real world efficacy. Any decrement in comfort is outweighed by the superior performance of the BPFDF over current PFDs.

The BPFDF shifts the onus of rotating the unconscious victim from buoyancy alone to a system combining ballast and buoyancy. The secondary gain associated with the advent of the BPFDF is that buoyancy now relieved of the task of rotation can be relocated from the ventral area to the peri-cervical-cephalo area where its displacement can be employed to improve freeboard enhancing victim viability in an inclement sea state rather than sitting uselessly above the water line upon the chest of the unconscious victim. Additionally, with the improved physics of self rescue accomplished by using a combined ballast/buoyant PFD, some of the buoyancy previously employed for rotation in prior art PFDs can be eliminated reducing bulk and further increasing comfort and compliance.

For the individual occupied around the water environment, a soft coating of the mobile keel **26a** and/or inner surface **25a** of the container can be provided to mute the sound of the movement of the ballasting member **1a**, promoting day in/day out comfort and compliance while retaining the advances of BPFDF's reliable airway protection.

Environmental concerns mandate that the keeling members, ideally of high density comport with environmental responsibility. Given the life span of the fabric bodice of the PFD it is preferred that a non-lead keel be selected, though such is not considered limiting. The corrosive marine environment can be negotiated by an epoxy coated ferrous material that would exceed the life span of the other component of the PFD and not lead to a lead recovery problem.

There is currently a movement under way to convert the current complex classification of PFD's which is Type I through V into a more succinct and clear labeling of life jackets. Type A & B. Clear labeling would identify Type A as Airway Protective and Type B as a Buoyant Aid but not airway protection. The Type B can be identified with a pictograph showing a slash across a victim floating in a face up position. Complementing the new direction in PFD nomenclature, a quick release coupling **12a** in the swing keel's arm **5a** can be provided to allow the recreational boater required to wear PFD to comply with the law by routinely wearing a Type B Buoyant Aid, but in the event of deteriorating weather or impending emergency the connection of ballasting member **1a** would allow the boater to upgrade the performance of their Type B PFD into a Type A Airway Protective PFD.

For the individual engaged in or about water, mobile ballast member **1a** can be restrained in an inactive position **42a** until released in the event of an emergency into its central active position **44a**. Such release converts the BPFDF from Type B into Type A. Ideally the outer shell of the PFD **50a** continues down towards the waist to envelope a secure belt **40a** to which the inactive immobilized ballast member **41a** is secured by a quick release means **42a**. In one embodiment, a pair of hook and/or loop fastening members can be closed or the immobilized ballast member **41a** by a releasable piece of hook and/or loop fastening member connected by a pull cord **43a** to the front of the BPFDF. The secure belt holding the ballast in close and tight proximity to

44

the body of the wearer **8a** allows the ballast to be comfortably borne by the hips of the wearer rather than swinging about on their back. The dual position BPFDF is preferably used with active water sports where the decision to convert from Buoyant Aid to Life Jacket occurs rarely, in contrast to the commercial Type A jacket which is only donned in the event of an impending emergency water entry.

Additionally the mobile ballast **1a** can be specifically adapted to inflatable PFD where it is stowed and restrained within the cover. Upon inflation of the buoyant chamber the mobile keel would be released into its active position.

Some of the advantages achieved with and/or features of the embodiments illustrated in FIGS. 53 through 60 include the following:

- (1) Mobile ballast member integrated into the buoyant means of a personal flotation device;
- (2) Mobile ballast member attached to life jacket by flexible means;
- (3) Mobile ballast member attachable at variable positions to the life jacket by flexible means;
- (4) Mobile ballast member attached to life jacket by flexible means held in inactive position until released;
- (5) Flexible means connected through swivel to ballast member;
- (6) Flexible means connected through quick release coupler to ballast member;
- (7) Mobile ballast member attached to life jacket by rigid means;
- (8) Rigid means connected through swivel to ballast member;
- (9) Rigid means connected through quick release coupler to ballast member;
- (10) Ballast member of spherical configuration to facilitate movement along arc;
- (11) Rigid convex surface over which ballast member rolls throughout the arc of rotation determined by attachment means;
- (12) Rigid convex surface integrated with displacement foam of life jacket;
- (13) Rigid cover limiting range of motion of ballast member;
- (14) Flexible cover limiting range of motion of ballast member;
- (15) Enclosed container restricting range of motion of ballast member;
- (16) Enclosed container with convex surface—With second intersecting surface angled caudally - With third intersecting surface angled dorsally;
- (17) Enclosed container permanently sealed off to create buoyant means, less than, equal to or greater than ballasting means;
- (18) Enclosed container reversibly sealed off to create buoyant means, less than, equal to or greater than ballasting means;
- (19) Container and or ballast means coated with sound absorbing material;
- (20) Mobile Ballast secured quick release inactive position—Secured to belt about waist;
- (21) Belt loosely connected to PFD contained in Fabric of outer shell;
- (22) Quick release mobile ballast secured to crotch strap securing PFD to wearer;
- (23) Mobile ballast immobilized within storage shell of inflatable PFD, released upon inflation; and
- (24) Inflatable.

EXHIBIT
Page 57 of 67 pages

US 6,558,082 B1

45

FIGS. 61 through 67 illustrate the eccentric fixed and mobile ballasted life jackets embodiments of the present invention. While sufficient ballast placed along the posterior midline of a PFD will create instability of the face down position and therefore eventually initiate the airway protective roll, central positioning requires significantly more ballast and time to destabilize the face down position. The current invention provides several embodiments that allow a relatively small keel to achieve, more rapidly and comfortably, reliable airway protection. Given that a stackable Type 1 PFD only weighs 3-5 lbs., the addition of excessive amounts of high density ballast is quite noticeable and uncomfortable to the wearer. Previously discussed tank mounted ballast for a typical midline keel weigh from the 6-8 lbs. The present invention reduces the weight to 1-2 pounds of highly effective eccentric mobile ballast.

In the fixed posterior midline position discussed above, the keel is stabilized directly above the center of buoyancy, the horizontal distance of the keel from the axis of rotation is consequently zero and the rotational energy generated by the fixed midline keel is also unfortunately zero. A keel located top dead center is described as being at zero (0°) degrees on the circumference about the victims axis of rotation.

When the keel is at ninety (90°) degrees the horizontal distance from the axis of rotation is at its maximum and therefore, for a given amount of ballast, so is the effort applied in rotation of the victim about their axis. When the keel is at one hundred eighty (180°) degrees it is suspended directly beneath the victim and the entire system's center of buoyancy. The effect of gravity upon the keel at one hundred eighty (180°) degrees is straight down once again i.e. no energy is being applied in an attempt to rotate the victim about their axis. This position, with the keel one hundred eighty (180°) degrees, places the victim face up airway protected and is the only stable moment in a correctly ballasted self rescuing BPPFD (Ballasted Personal Flotation Device). In the event that a large wave throws the victim over onto their face, once again the keel will seek its lowest point, suspended directly beneath the center of buoyancy, restoring airway protection.

The rate of self rescue is dependant upon numerous factors in addition to size of the keel and are discussed below. Compliance (the presence of the Life Jacket on the victim at the onset of a water emergency) has been shown to be critical in drowning prevention as opposed to the PFD carried aboard the vessel but stowed rather than worn. The eccentric mobile ballast of the present invention by either its site of attachment off of the midline or its rapid movement away from the midline is able to initiate the self rescue roll with relatively less energy input i.e. less weight. The eccentric keel optimizes the rotational energy per unit mass allowing reliable airway protection to coexist with wearer comfort which has been shown to be a non-negotiable bottom line necessary to achieve real world compliance and therefore efficacy.

There are a wide variety of prior art life jackets, with each design group unique in how they locate ballast about the victims neck and torso. What is referred to as the stackable PFD is a flat PFD that allows easy stowage. Some jurisdictions require the highest rated Life Jackets to roll a face down unconscious victim into and airway protected position within five (5) seconds in calm fresh water. FIGS. 61 through 67 illustrate a Yoke Style Collar or stackable PFD 66a having pericervical buoyant means 71a that supplies the displacement of the cervical collar 72a. FIG. 67 shows a

46

relatively simple, reliable attachment means for securing one or more ballast moments to the perimeter of an existing PFD. Without any ballast the existing PFD is a buoyant aid, i.e. only capable of airway protection if the conscious wearer can position themselves in a face up position. This buoyant aid may be all that can be tolerated or necessary. If an emergency were to arise and the wearer was in warm water wearing minimal clothing a single ballast element is sufficient, if the emergency arise in an inclement environment in which the impending water victim is wearing thermal protective clothing, two or more elements may be required to right an unconscious victim draped in water logged clothing. The eccentric ballast attachment member 126a is preferably comprised of a cylindrical ballast 100a which is threaded onto a strap 124a. The strap is secured by attachment means 121a to the mounting strap 120a that envelops the PFD. The mounting means 120a is secured by fastener member 122a which preferably makes a reliable connection by relying upon multiple overlapping surfaces. If this closure mechanism were to fail the ballast would drop away and the life jacket would be reduced back to an airway submerging buoyant aid. Similarly cover strap 123a secures and protects the ballast belt 124a from being snagged and possibly released with the same consequences described above. Stiffener 125a supplies critical rigidity necessary to prevent ballast 100a from sliding from its position on the PFD's lateral surface onto the PFD's ventral, dorsal or medial surface where the selected ballast may be insufficient to effectuate the self rescue roll. Notably ballast 100a is specifically selected so that it can be transferred to an integrated mobile ballast PFD as shown in FIG. 64. Once the ballast is located in a tubular containment member 87a it can be continued to be used indefinitely, allowing its cost and ecological impact to be minimized.

Typically, a PFD's inherently buoyant means is comprised of multiple layers placed symmetrically about the wearer. However, the size of eccentric ballast can be reduced removing a portion of the buoyant means whether inherently buoyant, inflatable buoyant or of mixed origin. The eccentric placement of buoyant means about the PFD can be used to facilitate the self rescue roll by reducing the symmetry as well as by reducing the size of the buoyant moment that must be submerged by the ballast during the initiation phase of self rescue (zero to ninety degrees).

The fixed, eccentric ballast as shown in FIG. 65 integrated into the construction of a new PFD locates the containment means 101a in an accessible area for wearer manipulation in the field. Significantly the jacket does not have to be removed in order to convert the jacket from a buoyant aid device into a Life Jacket with varying strengths of active self rescue. FIG. 67 shows a "fix" for PFDs currently in existence. The eccentric fixed ballast means 100a are only applicable to those select PFDs which through specific placement of the buoyant means of the PFD, only need assistance with the initiation phase of the self rescue roll, i.e. zero (0°) to ninety (90°) degrees. Once PFDs of this design are moved out of the stable face down position the buoyant means alone is capable of completing the phase two of self rescue, i.e. ninety (90°) to one hundred (180°) degrees.

Other PFD designs in order to achieve reliable airway protection with minimal amounts of ballast require mobility of that ballast means to assist not only with phase one initiation but with phase two completion of active self rescue. A mobile ballast requires a containment means to limit and direct the keels movement to effectuate the conversion of stabilize face down flotation into face up. In PFDs of this design an eccentric fixed keel will roll the victim off

EXHIBIT
Page 58 of 111 pages

US 6,558,082 B1

47

their back and onto their side where they become stabilized in a side high position. However, the unconscious victim's flaccid airway is severely flexed to the point of obstruction and their airway remains submerged. In this side high position the victim often rapidly succumbs to Shallow Water Drowning. Notably both the eccentric fixed and mobile ballast elements rely upon being located off the midline to achieve phase one rotation with a minimum amount of ballast.

As seen in FIG. 61, another embodiment is shown where an exterior attachment of a semi-circular container 60a containing a mobile ballast 1a allows existing jackets to acquire active self rescue. Container 60a and mobile ballast is of such a design that it can also be used within the cervical collar of a new stackable PFD. Container 23 and ballast 1 have a longer useful life expectancy than the fabric lives of several current PFDs. This recyclable feature allows the cost to be spread out over many jackets and minimizes the disposal problems presented by high density metals such as lead. Furthermore, the stackable PFD 66a of FIG. 63 shows a straight container means 87a within a fabric sleeve 83a attached to a fabric hood 80a secured to stackable PFD 66a by attachment means 81a allowing an in field fix of an existing stackable PFD. One advantage of straight container means 87a is it allows the use of one, two, as well as three or more mobile ballast elements 1a since they all stack up the same corner of the PFD. With semicircular 60a containment means 23a, mobile ballast 1a elements are preferably provided in an odd number (i.e. 1, 3, 5 . . .) to prevent an even distribution of the ballast elements. With only two elements one could be located at each end effectively balancing each other out leaving the victim floating face down. The advantage to multiple elements is that the container diameter can be reduced allowing easier manipulation as well as comporting with the size restrictions of infant or children's PFDs.

The stacking linear containment means finds slightly divergent applications in other PFD designs. The multiple stacking of the ballast elements moves and facilitates container 23a relocation as is necessary in effecting the first phase of active self rescue (i.e. zero (0°) to ninety (90°) degrees), then the ballast must relocate to the other end to optimally facilitate phase two of the active self rescue roll (i.e. ninety (90°) to one hundred eighty (180°) degrees.

While cervical container means 60a and 87a benefit from being closed in that they contribute displacement in the critical cephalic area, helping to maintain freeboard, the distance measured from the corner of the mouth to the water's surface, when used within the back of a vest style PFD, perforated end caps 101a allow the air to exhaust so that the container's displacement does not oppose the containers relocation during the conversion from phase one to phase two of the active self rescue roll.

Some of the advantages achieved with and/or features of the embodiments illustrated in FIGS. 61 through 67 include the following:

- (1) Eccentric Single or Multiple ballasting means, Attached to Inherently buoyant, Inflatable buoyant, or Hybrid buoyant, Personal Flotation device;
- (2) Fixed Eccentric ballast means;
- (3) (New Construction) Internal or external Integrated Fixed eccentric ballast member Accessible for placement and or removal, Inaccessible, combination of partially inaccessible with the option to add additional ballasting elements;
- (4) (Fix of in existing products) Externally Attached eccentric ballast member, with independent reversible

48

or Permanent attachment means, accessible, inaccessible, mixed;

- (5) Ballast Means, cylindrical or spherical for use in fixed and mobile ballast systems;
- (6) Mobile ballast member integrated into the buoyant means of a personal flotation device;
- (7) mobile ballast member attached to life jacket by flexible means;
- (8) mobile ballast member attachable at variable positions to the life jacket by flexible means;
- (9) Mobile ballast member attached to life jacket by flexible means held in inactive position until released;
- (10) Mobile ballast attached midline;
- (11) Eccentric mobile ballast member attached at point off midline;
- (12) Flexible means connected through swivel to ballast member;
- (13) Flexible means connected through quick release coupler to ballast member;
- (14) Mobile ballast member attached to life jacket by rigid means;
- (15) Rigid means connected through swivel to ballast member;
- (16) Rigid means connected through quick release coupler to ballast member;
- (17) Ballast member of spherical configuration to facilitate movement along arc;
- (18) Rigid convex surface over which ballast member rolls throughout the arc of rotation determined by attachment means;
- (19) Rigid convex surface integrated with displacement foam of life jacket;
- (20) Rigid cover limiting range of motion of ballast member;
- (21) Flexible cover limiting range of motion of ballast member;
- (22) Enclosed container restricting range of motion of ballast member;
- (23) Enclosed container with convex surface—with second intersecting surface angled caudally—with third intersecting surface angled dorsally;
- (24) Enclosed container permanently sealed off to create buoyant means, less than, equal to or greater than ballasting means;
- (25) Enclosed container reversibly sealed off to create buoyant means, less than, equal to or greater than ballasting means;
- (26) Vented non-buoyant container for mobile ballast;
- (27) pivoting straight container attached at laterally, swinging cephalo-caudal;
- (28) container and/or ballast means coated with sound absorbing material inflatable;
- (29) stiffener means;
- (30) asymmetric buoyant means; and
- (31) mobile buoyant means.

Individuals employed offshore are often supplied with whole body thermal protective garments 130a as seen in FIG. 68. Currently despite the garments massive buoyant moment such individuals are also required to wear a life jacket. The inclusion of eccentric fixed and mobile ballast and buoyant means of the present invention allows the buoyancy inherent in the thermal protective garment 130a to

US 6,558,082 B1

49

fulfill the dual purposes of warmth and surface support. FIG. 68 is a posterior view of one such exposure suit or thermal protective garment 130a. The traditional neoprene suit of a wind surfer or water enthusiast is likewise capable of protecting core temperature as well and is also considered with the scope of the invention. A ventral eccentric buoyant means 131a combines with a posterior eccentric buoyant means 132a to help destabilize the face down position. The addition of multiple ballast members such as a midline mobile ballast system 133a with an eccentric fixed ballast system maybe sufficient for a tight fitting neoprene protective garment. In the exposure suits designed for north sea offshore oil rigs there is a need for peripheral ballast members, 135a and 136a to assure the victim will maintain a heads up position. Preferably, the identified direction of turning is reinforced by the placement of eccentric ballast such that there is sufficient energy to initiate the first phase of self rescue, i.e. the size of 136a exceeds 135a. In the vertical position this difference is negligible.

Some of the advantages achieved with and/or features of the embodiments illustrated in FIG. 68 include the following:

- (1) Thermal protective gear with one or more eccentric fixed buoyant means;
- (2) Thermal protective gear with one or more eccentric mobile buoyant means;
- (3) Thermal protective gear with one or more eccentric fixed ballast means;
- (4) Thermal protective gear with one or more quick release eccentric fixed ballast means;
- (5) Thermal protective gear with one or more eccentric mobile ballast means; and
- (6) Thermal protective gear with one or more quick release eccentric mobile ballast means.

FIG. 69 illustrates a PFD Strap ballast embodiment in accordance with the present invention. One PFD design that is popular in children is a yoke type collar PFD or stackable PFD. The children's PFD does not lend it self to the same solution as the adult, i.e. the eccentric fixed ballast locate along the lateral cervical area. The combination of the child's body density, narrow pulmonary fields and predominance of mass in the cephalic area makes them resistant to the lateral ballast moment. FIG. 69 shows the wearer 8a wearing a stackable PFD 72a held by strap 65a. The ballast moment is spread by attachment means 142a along the posterior width of the individual. The ballast may be a lead shot 140a, though such is not limiting. Lead shot 140a, in a soft coating, preferably conforms to the body's surface. Alternatively, lead shot 140a may be comprised of small rigid blocks of ballast such as 141a. The posterior horizontal distributed ballast means 142a is located upon the back of the wearer 8a and held in place from slippage there from by a stiffener that conforms to the wearer 143a.

Alternatively, in FIG. 70 the child 8a wearing an inflatable PFD 31a achieves the keeling action from mobile ballast contained within a container 60a with curved surface 4a. The mobile ballast 1a is preferably attached to both ends ventilated end caps 150a, which allow water end thereby avoiding placement of a counterproductive buoyant moment low on the victim's back. Mobile ballast 1a is suspended from diametric points via left flexible means 151a and a right flexible means 152a. This dual suspension transfers across the midline of the victim to the opposite side of the ballast's location. FIG. 71 adapts this dual suspension to a strap attachment means 160a that can be added or built into the PFD strap 65a. Unrestrained mobile ballast 1a is free to

50

roll to either side yet when it reaches the end of its flexible arm 151a or 152a it exerts a turning force across the midline. As the self-rescue roll nears the end of the second phase, the mobile ballast is suspended from both arms and is located in the midline, swung away from the victim, stabilizing them in the safe zone. Due to the lack of a container that invariably restricts motion and consequently location, the open device can be of smaller size for a given rate of turning.

Some of the advantages achieved with and/or features of the embodiments illustrated in FIGS. 69 through 71 include the following:

- (1) Horizontal band of ballast, fixed or mobile along PFD Strap or belt or back of vest;
- (2) Body Stiffener conforming sized and conforming to the wearer;
- (3) Mobile ballast suspend from left and right arms;
- (4) Attached to PFD Strap;
- (5) Contained in ventilated means—With curved surface beneath mobile ballast

Eccentric and Mobile Ballast and Bouyancy Parts
List (FIGS. 53 through 71)

- 1a Mobile Ballast Member
- 2a Flexible Arm
- 3a Swivel
- 4a Curved Surface
- 5a Flexible Retaining Cover
- 6a Arm Attachment Point
- 7a Life Jacket
- 8a Wearer of PFD
- 9a Lower Edge of PFD Fabric Back Panel Covering Ballast Components
- 10a Pivoting Attachment Point
- 11a Rigid Arm
- 12a Quick Release Coupler
- 13a Rigid Retaining Cover
- 14a Conical Mobile Ballast
- 20a Container for Mobile Ballast Member
- 21a Lateral Gully Low Point
- 22a Caudal Gully Low Point
- 23a Posterior Gully Low Point
- 24a Airtight Lid for placing/servicing mobile ballast member
- 25a Sound Reducing Coating of inside of Container
- 26a Sound Reducing Coating of Mobile Ballast Member
- 27a Surrounding Foam of PFD
- 30a Stowed Inflatable PFD
- 31a Inflated PFD
- 32a Deflated PFD Retaining Cover
- 40a Secure belt
- 41a Inactive Immobilized Ballast Member
- 42a Quick Release Retainer Means
- 43a Quick Release Activation Means—Pull Cord
- 44a Activated—Mobile Ballast Member
- 50a Continuation of Outer Shell of PFD
- 51a Loop Portion of Hook and Loop Fastening Member/Quick Release Means
- 52a Hook Portion of Hook and Loop Fastening Member/Quick Release Means
- 53a Crotch Strap
- 60a Semi-Circular Container
- 61a Foam Pad insulating end cap
- 62a Resealable End Cap
- 63a Flexible Fabric Joint between Thoracic-Ventral and Cervical-Dorsal
- 64a Ventral Buoyant Means

EXHIBIT C
Page 10 of 11 pages

US 6,558,082 B1

51

- 65a PFD Strap
- 66a Yoke Collar Style or Stackable PFD
- 67a Resealable Closure for container
- 68a Cervical Foam Pad
- 69a Semicircular Fabric Hood
- 70a Resealable Closure Means
- 71a Layers of closed cell foam
- 72a Cervical collar of stackable PFD
- 80a Fabric Hood
- 81a Hood Attachment means
- 82a Tube Cap
- 83a Tube Sleeve Cover
- 84a Tube Sleeve Cover Opening
- 85a Tube Sleeve Closure Means, Loop Portion of Hook and Loop Fastening Member
- 86a Tube Sleeve Closure Means, Hook Portion of Hook and Loop Fastening Member
- 87a Straight tube Containing Mobile Ballast
- 88a Second Mobile Ballast Element
- 90a Ventral Surface of PFD
- 91a Posterior Surface of PFD
- 92a Cervical Buoyant Means Embedding Container means
- 93a Posterior-Medical End of Container Means
- 94a Ventral-Lateral End of Container Means
- 100a Eccentric Fixed Ballast Means
- 101a Ballast Container Means
- 102a Sealable Container Cover
- 110a Eccentric Inaccessible Mobile Ballast Element
- 111a Eccentric Accessible Mobile Ballast Element
- 120a Mounting Means for addition of Ballast, Strap
- 121a Attachment Point of Ballast Belt
- 122a Secure Closure Means
- 123a Safety Cover for termination of Ballast Belt
- 124a Ballast Belt for secure mounting of eccentric ballast
- 125a Stiffener Means
- 126a Eccentric Ballast Attachment Means
- 130a Thermal Protection Garment
- 131a Ventral Eccentric Buoyant Means
- 132a Posterior Eccentric Buoyant Means
- 133a Midline Mobile Ballast System
- 134a Eccentric Fixed Ballast System
- 135a Single Eccentric Peripheral Ballast Means
- 136a Multiple Eccentric Peripheral Ballast Means
- 140a Shot Ballast
- 141a Solid Block Ballast
- 142a Posterior horizontal distributed ballast means
- 143a Stiffener sized to conform to wearer
- 150a Ventilated End Cap
- 151a Left Flexible Arm
- 152a Right Flexible Arm
- 160a Attachment means for multiple suspended mobile ballast

As seen in FIGS. 72 through 90 a combined ballast and signaling device which is neutralized by attachment to an eccentrically buoyant PFD is disclosed and generally designated as reference numeral 1b. It is recognized that the role of the eccentric or midline, fixed or mobile, ballast or buoyant moment confers improved airway protection upon personal flotation devices ("PFDs"), which have been defined above. It is disclosed herein that the ballast associated with certain required attachments when appropriately sized, located and if required, minimally augmented, can confer a synergistic dual advantage enhancing airway protection as well as enhancing visibility to search and rescue efforts.

Standards agencies have not only approved but require that certain types of PFDs particularly commercial Safety Of

52

Life At Sea ("SOLAS"), Off-Shore Type 1 Life Jackets carry a lighting or illumination means 2b for assisting in the night time search and rescue efforts of individuals lost at sea. Other individuals making passage on lightly crewed vessels carry telemetry devices 40b that awaken sleeping crew alerting them to a man over board situation as well as demarcating their position on an electronic locating device aboard the vessel. Others advise carrying personal EPIRBS 25b (a signaling device) for assisting their being located day or night while adrift. These and other devices routinely attached to the PFD when specifically sized and located can supply the ballast that is critical in order to replace PFD stabilized airway submersion with active self rescue. i.e. a PFD that is capable of reliably rolling an unconscious victim's face out of the water without their assistance or reliance upon sea state to initiate the Life Jackets turning.

Since every PFD requires a different ballasting arrangement as previously disclosed, certain PFD designs may require the ballasting/powering element 24b, 37b to be connected to the light, strobe, transmitter, etc., preferably via a conductive cable 23b. Other PFDs, because of their design, lend themselves to a easier solution in which the batteries, case and appliance are all contained at a solitary site, where the mass of the device confers enhanced airway protection while concurrently providing wearer operable access to the signaling device. If necessary, an additional battery 11b or batteries can be added to assure that the requisite ballast requirement is met for active self rescue. Additionally, the materials for the container 12b might be selected to help fulfill a portion of the ballast requirements of a particular PFD, i.e. steel or lead instead of plastic. Further, as some devices exposed to moisture are packed in petroleum jelly 14b to decrease detrimental effects of water within the device, the packaging medium can be selected to meet or exceed the specific gravity of water so that the entire volume of the containment means contributes positively to the ballasting moment rather than sealing in air which would reduce the net ballast moment. A variably sized high density plug 13b can be attached as required by the individual PFD to meet the PFD's specific ballast needs, i.e. the remainder of the ballast and signaling device remains constant but if a particular brand PFD requires 2 lbs. instead of 1 lb., a different plug 13b can be attached. Attachment means 16b allows quick and secure retrofitting of PFDs in the field. Attachment means 16b can be an arm member, preferably rigid, whose distance from the PFD can be varied allowing the attached appliance increased range of motion and therefore increased efficacy in imparted rotational energy per unit mass of the combined ballast and appliance.

A new PFD would locate grommets to specify the exact location of existing ballasted appliance identifying where a ballasted appliance needs to be attached in order to assure ballast mediated airway protection. O-ring sealed switch 17b allows operation by the wearer. Alternately, the appliance device may be water activated in the event of unconscious water entry.

Ballasted signaling device 1b can be instantly mounted such as by a locking hook and loop fastening strap member 5b or safety pins 16 onto PFDs currently in the field allowing a fix to airway submersion that does not result in the attachment of yet another device to the PFD where it not only clutters the appearance but may confuse an obtunded individual seeking to differentiate their strobe light from their ballast fix (i.e. in the event of hearing a search and rescue vehicle approaching at night). Given the difficulty associated with trying to change regulatory standards to allow the attachment of a purely ballasting member to a PFD

US 6,558,082 B1

53

with its concomitant reduction in the net buoyancy of a life jacket, a combined ballast appliance device 1b of the present invention, only slightly augmented with additional ballast if necessary, can be immediately shepherded into the field without the paper work and time required to change international standards to accommodate the consequential reduction in the net buoyancy that would occur upon attachment of ballast on PFDs in the field. With newly constructed PFDs, the placement of the additional eccentric displacement means 101b on the ventral leg opposite the side where the ballast moment is attached 100b will neutralize any effective net loss of buoyancy.

Additionally, the intentional placement of a buoyant member 2b, 34b on the PFD can supplant or complement the need for a ballasting member in order to achieve active self rescue.

Buoyancy can be located in several places such as along the ventral midline of the victim 34b, where it alone or in combination destabilizes the airway submerged face down position. As previously disclosed a midline buoyant bubble wants to rise to the surface, shifting the wearer sufficiently off center so that the main buoyant elements of the PFD, with or without attached ballasting means, can come into play and thereby roll the victim over into an airway protected position.

Furthermore, an eccentric placement of a buoyant member 34b, 2b may take advantage of the differences of the right pulmonary fields preponderance of displacement versus the left lung field which is reduced by the volume of the intrusion of the pericardial sac with its fluid and muscular contents. While there is a predictable incidence in which the location of the heart is reversed, it typically is not a factor to be ignored in positioning.

Any container sized, sealed and or selected so as to be sufficiently buoyant, such as the device purely for displacement 34b or one with alternate function such as a means of illumination 2b, can be located in either a midline or eccentric position and if of sufficient buoyancy it alone can shift the victim out of the zero (0°) degree face down position. Obviously, separation of a products buoyant moment from its ballasting moment and thereby positioned to optimize turning, could combine in a synergistic fashion to accomplish enhanced airway protection while assisting in search and rescue. If additional batteries are needed for ballast purposed, they can also provide for extended operation or increased brilliance and range of signaling devices, that may also prove life saving.

As part of the responsibility for turning over the unconscious victim is borne by ballast, the buoyant means can be redistributed to where more of its displacement is located about the head and neck 33b. In this place, increased freeboard is achieved for a given displacement PFD. A side entry PFD as seen in FIG. 76 allows the central ventral position to be occupied by an asymmetric ventral buoyant means 34b where the displacement mimics a horse collar life jacket. The central preponderance creates an instability of the face down position and drives the first phase of self rescue, 0° to 90° degrees. The lateral ventral component only has to be sufficient to power the rescue through phase 2, 90° to 180° degrees. Complementing this is the dual arm mobile ballast battery means 37b which is attached across the victims midline so that the rotational energy will be applied past 90° degrees. The mobile ballast comes back to a central position once the victim reaches 180° degrees or face up. The cephalo-cervical cradle 33 bcan be securely snugged up by the wearer operating straps 3 lb locking the head from rolling off to the side. Secure and correctly

54

positioned straps and fasteners are preferably provided to prevent the wearer from slipping down in the PFD. Furthermore, a crotch strap 4 lb with secure fastener means 42b is also preferably provided for keeping the buoyant moments in their correct position on the flaccid victim.

FIG. 77 shows a current configuration for a yoke collar style PFD, generally designated as reference numeral 50b, which includes three pieces of foam that currently comprise each layer, one cervical piece 5 lb and two ventral pieces 52b. This configuration has been grand fathered in to its current position as an industry standard based on ease of sewing and assembly. Configuration 50b stacks all the foam joints bilaterally in the lateral cervical area. In FIG. 72, the locking attachment means 5b not only secures the combined ballast and appliance device and stiffener to the outside perimeter where it prevents the ballast and combined signaling devices migration from the ideal point of attachment, the stiffener also preferably structurally ties together the ventral and cervical foam of the PFD. As seen in FIG. 87 the stiffener can be shaped as a right angle where the anterior stiffener 65b can be neutrally buoyant while the lateral stiffener 60b can be constructed out of a high density material and thereby comprise an internal fixed ballast. The combination of stiffeners on two sides preferably locks the combined ballast and signaling device securely to the PFD.

FIG. 77 illustrates a relatively simple solution for a newly constructed PFD which preferably includes additional units of ventral foam piece 52b. In a SOLAS grade PFD, depending on the thickness of foam selected by the manufacturer, as little as two additional pieces of foam on top of the usual 8b piece construction produces enough of a difference in the left versus right ventral buoyant members to shift the flaccid victim off center and thus initiate phase one of active self rescue.

Another cost effective configuration for a newly constructed PFD, is a PFD built from a simple two piece foam layer arrangement 53b then stacked as in FIG. 84. This eliminates the lateral joint and thereby allows the attachment of the lateral ballast a more complete purchase on the ventral and a portion of the cervical displacement means.

Adding considerably to the complexity of sewing the fabric shell and then stuffing that fabric shell with the foam layers, are the foam layer stacking arrangements as shown in FIGS. 82 and 83. An oversized base layer 56b as seen in FIG. 85 allows the anterior coated fabric shell 61b and the posterior coated fabric shell 62b to be sewn through the foam base layer integrating the PFD structurally. Currently PFD fabric is uncoated allowing it to stretch and loosen resulting in increased laxity of the cervical-ventral joint. A coated one side fabric can greatly extend the life of the PFD and if the applied SOLAS tape were sufficient and the coating was placed outside there can be fabric protection form UV, petroleum products, salt water, etc. Depending on whether the PFD is designed to be classified as a PFD that will be required to carry a signaling device, the stiffener can be in part or completely comprised of high density ballasting means 60b which can be joined to the fabric and foam at the peripheral seam or encased in a pocket along the side of the PFD. A binding tape 61b covers and reinforces the joint. The combined ballast and signaling means 1b is secured via fastener means 64b at the ideal site as determined by the arrangement of buoyant means in a particular PFD.

Compliance from a child asked to wear a PFD all day long may necessitate greater flexibility of the lateral cervical joint as in the alternating stacking arrangement of FIG. 83, yet the base layer and alternating layers supply improved structural integrity to the foam elements that must effectively receive

EXHIBIT
Page 159 of 167 pages

and transfer the rotational energy from the ballast means to the victim. FIG. 82 shows a stacking arrangement which will confer even greater rigidity on the ballasted side since there are no lateral cervical joints. While this results in less flexibility and comfort it increases efficacy per unit mass of ballast. On the opposite side of FIG. 82 all the joints lie in a line conferring greatest flexibility for ease of entry allowing the PFD to flex about this joint while donning the device. PFDs constructed as in FIGS. 82 and 83, as do all PFDs, benefit from the inclusion of an eccentric fixed buoyant moment in the side opposite from the side carrying the ballast moment. This can be achieved through the use of foam pieces such as 52b or 55b as shown in FIG. 77.

Certain Types of PFDs designed for commercial cold water use where the wearer is likely to be wearing thermal protective clothing can include the foam layer stacking arrangement. FIG. 81 is comprised of solid single pieces 57b resting upon an oversized base layer 56b and sometimes capped by another oversized layer conferring the greatest PFD structural rigidity short of solid foam. The use of layers confers a real advantage in conforming the PFD to the wearer and in adjusting to movement by the wearer as the PFD is bent over the wearer and as the wearer bends, twists etc. Ideally such a stacking arrangement includes the minimum buoyant offset such as foam piece 55b, to assure minimal performance under ideal conditions, i.e. tester wearing only a bathing suit as it currently is the sole testing standard despite its short comings when mapped to a real world disaster in the open ocean.

The reduction or elimination of the lateral cervical joint allows the rotational energy of the combined ballast and appliance to more fully applied to rolling the PFD and wearer into a face up position. In current PFDs a lot of the energy is used to deform the fabric shell twisting the lateral cervical joint. The energy that is transferred impacts primarily either the posterior cervical part 5 lb or the ventral foam part 52b where it acts independently and if the ballast is insufficient to the PFD inadequately attached to the wearer, the ballast will be suspended below the buoyant component allowing the airway to remain submerged. Current PFD foam layer structure requires unnecessarily excessive ballast to be attached in order for the PFD shell to first be twisted, next the ventral component moved then the cervical before the victim can be rolled into an airway protective position.

Ideally, the yoke collar style PFD shape can be retained yet free board optimized while keeping the ballasting appliance to a minimum by using a stacking arrangement as shown in FIG. 79. As shown, the PFDs foam layers build upon an oversized base layer 56b. Succeeding layers then alternate partial single piece layers 55b such that there is a preferential build up of displacement behind the head and neck of the wearer. Depending on how many layers are stacked, this can result in an effective conversion of ventral displacement means toward the neck where it can now be used to enhance free board rather than sit out of water upon the chest of the victim where the majority of the ventral foam can be found and where it does not contribute to displacement or free board. This stacking arrangement in a finished PFD is shown in FIG. 86. The inclusion of two additional ventral elements on one side relative to the other incorporates the fixed eccentric buoyant means necessary and sufficient to meet minimal turning performance. Positioning the combined ballast and signaling device on a vertical pivoting attachment along the opposite ventral buoyant means improves the aggressiveness of the airway protective turning moment of such a PFD.

The efficacy of the PFD, as measured by its airway protection, is enhanced if the buoyant ventral means 100b,

which in FIG. 86 is shown as the right side of the PFD, is constructed with enhanced displacement relative to the left side or ballasted ventral means 101b. This creates an eccentric fixed buoyant means that destabilizes the face down position. If the PFD's differential ventral buoyant means are adequately designed and constructed, an eccentric inherently buoyant PFD can be sufficient to provide airway protection. Ideally, the combination of a ventral buoyant discrepancy combined with a correctly located and attached combined ballast and signaling device provides the PFD with a brisk and reliable rotation of the victim out of the face down position and into the face up position with the least amount of physical divergence from the currently configured PFD as stowed aboard many commercial vessels.

The above advantages as detailed in the PFD constructed from foam layers applies to the solid foam PFD. The enhanced ventral buoyant moment complements the correctly positioned ballast or combined ballast and appliance. That combined efficacy allows for a shift of some of the displacement towards the head and neck where it increases the distance from the waters surface to the victim's airway.

Towards further securing the effective application of energy per unit of ballast 1b towards effective self rescue rotation, is cinching strap 72b, which encircles the ventral stacked foam layers on the ballasted side of the PFD. Once the PFD is placed on the wearer the foam layers slide into their final position at which time strap 72b is now tightened, compressing the foam layers. Once the strap is tightened it connects the stacked layers to the oversized base layer where they connect to the fabric shell and combined ballast and signaling means. A second strap 73b can also be provided and encircles the opposite ventral stack further unifying the PFD structurally. Certain body types and or use of thermal protective clothing, make the in water vertical position markedly stable and may require an additional posterior cervical mobile or fixed ballast device 75b, similarly attached to the base foam layer and fabric shell of the PFD.

For an individual working in foul weather wearing significant amounts of clothing it can be important to further amplify the rotational energy supplied per unit mass of a ballast regardless of its source. FIG. 87 illustrates an externally applied rigid lever arm 80b with an attached 90° degree stop 81b that prevents the ballast from swinging past the 90° degree point. In the active position the ballast is moved away from the victim's axis of rotation and held in this position of greatest rotational impact on the face down victim. A second significant advantage of amplifying the ballast's impact by moving it outboard is that it lengthens the lever arm from the vertical axis, generating the additional leverage needed to pry the flaccid victim out of the face forward slump. When the victim is vertical in the water column in what is called the 'PFD Dangerous Zone', i.e. 0° to 20° degrees from vertical, just before losing consciousness there is a strong tendency for the victim to slump forward when they pass out. If the victim slumps forward he or she may hang from their PFD, airway crimped and face in the water, where he or she may quickly drown. With the swing ballast at its greatest distance from the victims vertical axis, the victim is rocked off to the side where the ventral buoyancy is now free to rise towards the surface, swinging the person on their back, airway protected.

Arm 80b and stop 81b are preferably connected to a ballast plate 82b upon which can be mounted an attachment cover supporting a range of additional ballasting devices via a quick release attachment means 86b for securing a simple ballast 87b or a combined ballast and appliance such as is shown in FIG. 73. The swing arm is attached by a secure

EXHIBIT C
Page 60 of 62 pages

US 6,558,082 B1

57

locking means such as might be comprised of an outer jaw 85b and inner jaw 88b. A stiffener of ballasting stiffener 60b improves the conversion of the torque applied to the tubular arm guide 83b into rotation of the wearer rather than into deformation of the PFD. FIG. 88 shows an integrated eccentric mobile swing arm with a combined ballast and appliance device 1b with additional ballasting power supply 11b, regulated by switch 3b power signaling/illumination device 2b. The tubular hinge 83b is preferably secured to the over sized top layer of foam further improving the transfer of the kinetic energy of the ballast into rotation of PFD buoyant means. As the efficacy per unit mass is advanced the buoyant means of the PFD can be reallocated from subserving the responsibility of rolling over the obtunded victim to support the flaccid victim's head and neck, i.e. buoyancy can be removed from ventral means 71b and placed behind the head and neck 70b conferring increased freeboard or distance of the victim's nose and mouth from the water line.

SOLAS Life Jackets when used commercially are required to carry an illumination or signaling device, a preferred embodiment of such is shown in FIG. 89 demonstrates how the combined ballast and signaling means is divided into a long arm that extends towards the rear of the wearer. At the extreme end of the long arm is located the highest density ballast so that when the combined ballast and signaling device swings about attachment means 16b that pivots freely through mounting means 91b, the ballasted end is moved laterally to the point furthest from the axis of rotation. Alternatively, when the victim is floating face up, the long arm of the ballast end swings the device back adjacent the lateral edge of the PFD which now positions the short buoyant arm straight up so that the illumination means 2b is out of the water and visible from 360° degrees. If the victim enters the water face down or is rolled over onto their face by a wave, the long arm of the device swings out approximately 90° degrees moving the ballast to its optimal position of approximately 90° degrees to the victim's axis of rotation. In this position, the ballast is maximally effective at applying torque to the victim and their PFD in order to rotate their face out of the water. As the long arm of the ballasted end of the device approaches 90° degrees the short buoyant arm is simultaneously moved medially where the impact of the buoyancy is reduced to its minimum in terms of opposing active self rescue. The short buoyant arm of the combined ballast and signaling device preferably acts as a 90° degree stop arresting the swing from perpendicular to horizontal relative to the ventral face of the PFD. In the stop position, the short buoyant arm of the device rests against the face of the PFD. FIG. 90 shows a preferred embodiment where the short arm buoyancy is reduced to its practical minimum thereby reducing the need for offsetting ballast. Once the victim is rolled over into a face up position, the ballast swings back in reducing the ballast's distance from the victim's axis of rotation thereby reducing the ballast's impact or lowering the corner of the mouth of the victim towards the water (i.e. thereby maintaining as much freeboard as possible).

FIG. 90 also illustrates a secure and simple mounting means for a combined ballast and appliance. Preferably, a sewable plastic piping 92b is integrated into the seam of the PFD spaced to accommodate the appliance's hinge means 91b. The section of tubing can be die cut to be removed leaving the sewable flange so that the space for the appliance can be consistently close for optimal support yet sufficient to allow easy assembly. Hinge pin 93b serves multiple functions; it secures combined ballast and signaling device 1b through the sleeve means integrated into the PFD 92b in a

58

secure but preferably releasable manner. It rigidifies the cervical-ventral joint. The placement of multiple sewn in sleeves 92b which contain their hinge pin 93b, with or without a combined ballast and appliance device, can supply rigidification of the cervical-ventral joint complementing PFD turning due to ballast(s) at other locations. Furthermore, when sleeve means 92b is sewn onto the oversized foam layer 63b it further advances the transfer of the positional energy of the ballast into rotation of the PFD/victim reducing the amount of ballast required for reliable active self rescue.

PFD with Attached Combined Ballast and Signaling Parts List (FIGS. 72 through 90)

- 15 1b Combined ballast and signaling means
- 2b Continuous or stroboscopic illuminating means
- 3b Wearer operable appliance switch
- 4b Elongated battery containment means
- 5 5b Locking attachment means for securing ballasted signaling device
- 6b PFD wearer
- 7b Yoke Collar Style PFD
- 8b Cervical Side Joint stiffener
- 9b Cervical joint strap and stiffener for non-ballasted side
- 10 10b Light source
- 11b Additional ballasting batteries
- 12b Thickened high-density wall of container
- 13b Variably Sized High density plug
- 14b High density water excluding packing medium
- 15b O-Ring sealed threaded connector
- 16b Secure attachment means
- 17b O-Ring Sealed Switch
- 20b Vest Style PFD
- 21b Mobile ballast battery container means
- 22b Single attachment point
- 23b Conductive cable connecting ballasting batteries to appliance
- 24b Additional parallel ballasting batteries
- 25b Signaling Device
- 30b Cephalic Cradle portion of second buoyant means
- 31b Dual securing straps for cephalo-cervical buoyant cradle
- 32b Cervical cradle portion of second buoyant means
- 33b Cephalo-Cervical Cradle
- 34b Asymmetric ventral buoyant means
- 35b Dual securing means for ventral buoyant means
- 36b Thermal protective inner liner for two part PFD
- 37b Dual arm mobile ballast battery means
- 38b Ballasting battery units
- 39b Right arm attachment point
- 40b Appliance
- 41b Crotch strap
- 42b Secure-Fastener Means
- 50b Existing foam components for Yoke Collar Style PFD
- 51b Cervical foam component of a traditional Yoke Collar Style PFD
- 52b Ventral foam component of Yoke Collar Style PFD
- 53b Alternate configuration for foam layer showing Single Posterior-Cervical Joint
- 54b Alternate foam layer configuration showing two piece layer with Single Side Cervical Joint
- 55b Alternate Single Piece layer combining cervical and ventral components
- 56b Over sized single piece base foam layer
- 57b Regular sized single piece foam layer
- 60b Combined Internal Ballast Component and lateral Stiffener
- 61b Ventral Coated Fabric Cover

62b Dorsal Coated Fabric Cover
 63b Binding Tape
 64b Combined Ballast and Appliance Fastener means
 65b Anterior Stiffener
 70b Amplified Cervical Displacement means
 71b Relatively reduced ventral displacement means
 72b Ballast attachment side, PFD Foam Layer Compressing chest strap
 73b Alternate side PFD Foam Layer Compressing chest strap
 74b Chest strap retainer guide
 80b Rigid Swing Arm of mobile ballast
 81b 90 degree Range of Motion Stop
 82b Internal Ballast Plate
 83b Tubular liner guide
 84b Ballast Attachment cover
 85b Locking Attachment means for mobile swing ballast and lever arm
 86b Quick Release attachment means for ballast
 87b Ballast means
 88b Inner Locking Jaw
 90b Buoyant arm of device
 91b Hinge Pivot means of appliance
 92b Sleeve means integrated into PFD
 93b Hinge pin means
 94b Hinge pin retainer means
 95b Reduced Volume Buoyant Arm
 96b Die cut sewable plastic sleeve means
 100b Enhanced non-ballasted ventral component
 101b Relatively diminished ballasted ventral component
 Some of the advantages achieved with and/or features of the embodiments illustrated in FIGS. 72 through 90 include the following:

- (1) Combined Rotational and Functional Ballast attached to Life Jacket;
- (2) Ballast that is comprised in total or part by power supply means;
- (3) Ballast that is comprised in total or part by signaling, illumination or appliance means;
- (4) Ballast that is comprised in total or in part by containment means;
- (5) Ballast that is comprised in total or in part by high density component to offset buoyant functional components;
- (6) Ballast that is comprised in total or in part by neutral or negative packing fluid/gel;
- (7) Ballast that is comprised in total or in part by high density stiffener/attachment means complementing functional ballast means;
- (8) Fixed midline functional ballast/power supply/appliance;
- (9) Fixed eccentric functional ballast/power supply/appliance;
- (10) Mobile midline functional ballast/power supply/appliance;
- (11) Mobile eccentric functional ballast/power supply/appliance;
- (12) Dual Arm Mobile functional ballast/power supply/appliance;
- (13) Ballast power supply connected to remote appliance;
- (14) Attached buoyant device eccentric;
- (15) Attached buoyant device midline;
- (16) Eccentric shaped midline buoyant means;
- (17) Independent cephalo-cervical buoyant cradle means;

- (18) Buoyant thermally protective inner shell of PFD;
- (19) Rigid arm attachment means for mobile eccentric functional ballast/power supply/appliance;
- (20) Interchangeable variable rigid arm length of attachment means for mobile eccentric functional ballast/power supply/appliance;
- (21) Flexible arm attachment means for mobile eccentric functional ballast/power supply/appliance;
- (22) Neutrally buoyant ballast and foam means attached at opposite sides to PFD;
- (23) Placement of ballast offsetting foam in ventral leg opposite of site of ballast attachment;
- (24) Reduced single sided lateral cervical joints, through foam layer design(selection, construction);
- (25) Reduced bilateral cervical joints, through foam layer design;
- (26) Eliminate s single sided lateral cervical joints, through foam layer design;
- (27) Eliminates bilateral cervical joints, through foam layer design;
- (28) Oversized foam base layer sewn into fabric shell of life jacket;
- (29) Oversized foam top layer sewn into fabric shell of life jacket;
- (30) Alternating incomplete foam layers increasing cervical displacement relative to ventral displacement;
- (31) Alternating incomplete foam layers increasing the buoyant lateral ventral displacement relative to the opposite ballasted ventral side;
- (32) Alternating incomplete foam layers increasing both cervical displacement means relative to ventral and increasing the buoyant lateral ventral displacement relative to the opposite ballasted ventral side;
- (33) PFD of solid foam construction with eccentric displacement means;
- (34) PFD of solid foam construction with left right ventral components of unequal displacement means;
- (35) PFD of solid foam construction with cervical and ventral components of unequal thickness of displacement means;
- (36) PFD of solid foam construction with eccentric displacement means where side with attachment means for ballast or combined ballast and appliance device is reduced relative to the opposite ventral means;
- (37) PFD of solid foam construction with eccentric displacement means where side with attachment means for ballast or combined ballast and appliance device is reduced relative to width and or thickness and or length of the opposite ventral means;
- (38) PFD of solid foam construction with eccentric displacement means where side with attachment means for ballast or combined ballast and appliance device is reduced relative to wedge shaped opposite ventral buoyant means;
- (39) Ballast sided foam layer compressing strap means;
- (40) Bilateral foam layer compressing strap means;
- (41) Rigid swing arm with stop;
- (42) Rigid swing arm supported by tubular hinge;
- (43) Rigid swing arm with attached ballast component;
- (44) Fabric encased ballast plate;
- (45) Tubular fabric webbing encased ballast plate/framework;

EXHIBIT C
Page 65 of 67 pages

61

- (46) Dual eye ballast attachment points for attaching ballasted signal device;
- (47) Stiffener attached to swing arm hinge;
- (48) Rigid swing arm with stop attached to inherent buoyant means;
- (49) Wearer operable ballasting appliance attached to rigid swing arm with stop;
- (50) Water activated ballasting appliance attached to rigid swing arm with stop;
- (51) Appliance housing with Horizontal mounting means;
- (52) Appliance housing with Horizontal mounting means paralleling illumination means;
- (53) Appliance housing with Horizontal mounting means paralleling signaling means;
- (54) Appliance housing with Horizontal mounting means paralleling appliance means;
- (55) Mounting means of Ballasted signaling device separating housing into buoyant and ballasting sections;
- (56) Mounting means of Ballasted signaling device separating housing into short buoyant and long ballasting sections;
- (57) Container means of combined ballast and signaling device with reduced buoyant illumination component of short buoyant arm that stops against the anterior face of PFD;
- (58) Container means of combined ballast and signaling device with enhanced ballast at extreme end of long ballast arm that stops at the greatest distance from the PFD axis of rotation;
- (59) Pivot means dividing combined ballast and signaling device into buoyant anterior stop arm and ballasted rigid posterior swing arm;
- (60) Dual position ballasted signaling device, ballast lateral in prone position;
- (61) Dual position ballasted signaling device, ballast medial in supine position;
- (62) Buoyant signaling means forward of pivot means;
- (63) Buoyant signaling means forward of pivot means adapted to lie parallel to anterior face of PFD in active position;
- (64) Buoyant signaling means forward of pivot means adapted to extend perpendicular to PFD in face up position and lie along anterior face of PFD in ballast active face down position;
- (65) Dedicated ballast and Power located ballast posterior of pivot means;
- (66) Sewable plastic sleeve hinge component means;
- (67) Die cut sewable single piece hinge component;
- (68) PFD with integrated hinge means;
- (69) PFD with plastic sewn in hinge means;
- (70) PFD with multiple standardized hinge components;
- (71) PFD with ventral cervical hinge component with hinge pin;
- (72) PFD with ventral cervical hinge component with rigid hinge pin;
- (73) PFD with ventral cervical hinge component with semi-rigid hinge pin;
- (74) PFD with ventral cervical hinge component with hinge pin with combined ballast and appliance device;
- (75) Illumination or appliance strap means that splints one or both lateral cervical joints;
- (76) Stiffener means externally applied that splints one or both lateral cervical joints;

62

- (77) Stiffener means integrated during construction that splints one or both lateral cervical joints;
- (78) Attachment means stiffener on both lateral and anterior sides;
- (79) Lateral attachment means stiffener constructed of high density material;
- (80) Anterior attachment means stiffener constructed of low density material; and
- (81) Non Inflatable PFD constructed of coated fabric.

The instant invention has been shown and described herein in what is considered to be the most practical and preferred embodiment. It is recognized, however, that departures may be made therefrom within the scope of the invention and that obvious modifications will occur to a person skilled in the art.

We claim:

1. A counterweight assembly for providing heads up surface positioning of a person, said counterweight assembly comprising:

a weight member; and
 means for attaching said weight member to a personal flotation device, the personal flotation device worn by the person;

wherein said weight member rotates the person to ensure heads up surface positioning if the person becomes incapacitated;

wherein said weight member is a combined ballast and signaling device.

2. The counterweight assembly of claim 1 wherein said personal flotation device is a life vest.

3. The counterweight assembly of claim 1 wherein said personal flotation device is eccentrically buoyant and said combined ballast and signaling device are neutralized by attachment of said personal flotation device.

4. The counterweight assembly of claim 1 wherein said personal flotation device is a buoyancy compensator.

5. The counterweight assembly of claim 1 wherein said personal flotation device is a life jacket.

6. The counterweight assembly of claim 1 wherein said personal flotation device is an inflatable garment.

7. The counterweight assembly of claim 1 wherein said personal flotation device is a garment worn by a person in the water.

8. A counterweight for providing heads up surface positioning of a person, said counterweight comprising:

a weight member adapted for non-releasable attachment to a personal flotation device by a person while being worn by the person;

wherein said weight member aids in rotating the person to ensure heads up surface positioning if the person becomes incapacitated.

9. The counterweight assembly of claim 8 wherein said personal flotation device is a buoyancy compensator.

10. The counterweight assembly of claim 8 wherein said personal flotation device is a life jacket.

11. The counterweight assembly of claim 8 wherein said personal flotation device is an inflatable garment.

12. The counterweight assembly of claim 8 wherein said personal flotation device is a garment worn by a person in the water.

13. The counterweight assembly of claim 8 wherein said personal flotation device is a life vest.

EXHIBIT C
Page 109 of 111 pages

US 6,558,082 B1

63

14. A buoyancy compensator comprising:
a buoyancy compensator body member; and
at least one weight member secured to said buoyancy
compensator body member;
wherein said weight member aids in rotating a person
wearing said buoyancy compensator body member to
ensure heads up surface positioning if the person
becomes incapacitated.
15. The buoyancy compensator of claim 14 wherein said
at least one weight member is secured to said buoyancy
compensator body member such that it is non-releasable by
a person while the buoyancy compensator weight member is
worn by the person.

64

16. A buoyancy compensator comprising:
a buoyancy compensator body member; and
at least one weight member secured to said buoyancy
compensator body member;
wherein said at least one weight member is secured to said
buoyancy compensator body member such that it is
non-releasable by a person while the buoyancy com-
pensator weight member is worn by the person;
wherein said weight member aids in rotating the person to
ensure heads up surface positioning if the person
becomes incapacitated.

* * * * *

EXHIBIT D

ASSIGNMENT

CO-INVENTOR/ASSIGNOR: WILLIAM L. COURTNEY
Residence Address: 1990 Highway One
Elk, California

CO-INVENTOR/ASSIGNOR: ROBERT M. CARMICHAEL
Residence Address: 940 N.W. First Street
Fort Lauderdale, Florida 33311

ASSIGNEE: THE CARLEIGH RAE CORP.
Status: Small Entity
Address: 940 N.W. First Street, Fort Lauderdale, Florida 33311

TITLE OF INVENTION: WATER SAFETY AND SURVIVAL SYSTEM
U.S. Patent No.: 5,855,454
Issued: January 5, 1999

TITLE OF INVENTION: WATER SAFETY AND SURVIVAL SYSTEM
U. S. Patent No.: 6,530,725
Issued: March 11, 2003

**TITLE OF INVENTION: COMBINED BALLAST AND SIGNALING
DEVICE FOR A PERSONAL FLOTATION DEVICE**
U.S. Patent No.: 6,558,082
Issued: May 6, 2003

The Co-Inventors/Assignors are the owners of the above-referenced claimed inventions and owners of the above-referenced United States Patents, and the Assignee is desirous of acquiring the same. In consideration of Ten Dollars (\$10.00) and other good and valuable consideration, the Assignors hereby assign to the Assignee, including its successors, assigns, heirs, administrators, all of the Assignor's right, title and interest in and to the claimed inventions reflected in the above-identified United States Patents, including the right to sue for damages for all past infringement occurring prior to the execution date of this Assignment; and

The Assignors agree to execute any papers or perform any acts required to establish, vest or protect the Assignee's rights therein or required by Assignee to obtain said patents, without any additional payment therefor, but without any expense to Assignors.

Date: August 14, 2003

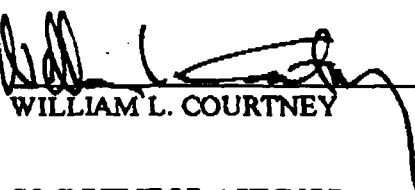
CO-INVENTOR/ASSIGNOR:

WILLIAM L. COURTNEY

Date: 14 August 2003

CO-INVENTOR/ASSIGNOR:

ROBERT M. CARMICHAEL

CIVIL COVER SHEET

The JS-44 civil cover sheet and the information contained herein neither replace nor supplement the filing and service of pleadings or other papers as required by law, except as provided by local rules of court. This form, approved by the Judicial Conference of the United States in September 1974, is required for the use of the Clerk of Court for the purpose of initiating the civil docket sheet. (SEE INSTRUCTIONS ON THE REVERSE OF THE FORM.)

I. (a) PLAINTIFFS
Carleigh Rae Corporation

(b) COUNTY OF RESIDENCE OF FIRST LISTED PLAINTIFF Broward
 (EXCEPT IN U.S. PLAINTIFF CASES)

DEFENDANTS **CIV - SEITZ**
Custom Buoyancy Inc.
MAGISTRATE BANDSTRA

COUNTY OF RESIDENCE OF FIRST LISTED DEFENDANT Los Angeles
 (IN U.S. PLAINTIFF CASES ONLY)

NOTE: IN LAND CONDEMNATION CASES, USE THE LOCATION OF THE TRACT OF LAND INVOLVED.

(c) ATTORNEYS (FIRM NAME, ADDRESS AND TELEPHONE NUMBER)
John Bradley for John Bradley and Associates P.A.
215 E Broward Blvd Ste 200 Ft. Lauderdale, FL 33301
(561) 523-6160

ATTORNEYS (IF KNOWN)
Broward 0:03cv61798 PAS/TEB

(d) CIRCLE COUNTY WHERE ACTION AROSE: DADE, MONROE, **(BROWARD)**, PALM BEACH, MARTIN, ST. LUCIE, INDIAN RIVER, OKEECHOBEE HIGHLANDS

II. BASIS OF JURISDICTION (PLACE AN "X" IN ONE BOX ONLY)

1 U.S. Government Plaintiff
 3 **Federal Question** (U.S. Government Not a Party)
 2 U.S. Government Defendant
 4 Diversity (Indicate Citizenship of Parties in Item III)

III. CITIZENSHIP OF PRINCIPAL PARTIES (PLACE AN "X" IN ONE BOX FOR PLAINTIFF AND ONE BOX FOR DEFENDANT)

	PTF	DEF		PTF	DEF
Citizen of This State	<input type="checkbox"/> 1	<input type="checkbox"/> 1	Incorporated or Principal Place of Business in This State	<input type="checkbox"/> 4	<input type="checkbox"/> 4
Citizen of Another State	<input type="checkbox"/> 2	<input type="checkbox"/> 2	Incorporated and Principal Place of Business in Another State	<input type="checkbox"/> 5	<input type="checkbox"/> 5
Citizen or Subject of a Foreign Country	<input type="checkbox"/> 3	<input type="checkbox"/> 3	Foreign Nation	<input type="checkbox"/> 6	<input type="checkbox"/> 6

NIGHT BOX FILED SEP 30 2003

IV. ORIGIN (PLACE AN "X" IN ONE BOX ONLY)

1 Original Proceeding
 2 Removed from State Court
 3 Remanded from Appellate Court
 4 Reinstated or Reopened
 5 Transferred from another district (specify) CLERK, USDC District of Columbia
 7 Appeal to District Judge from Magistrate Judgment

V. NATURE OF SUIT (PLACE AN "X" IN ONE BOX ONLY)

A CONTRACT	A TORTS	FORFEITURE/PENALTY	A BANKRUPTCY	A OTHER STATUTES
<input type="checkbox"/> 110 Insurance <input type="checkbox"/> 120 Marine <input type="checkbox"/> 130 Miller Act <input type="checkbox"/> 140 Negotiable Instrument <input type="checkbox"/> 150 Recovery of Overpayment & Enforcement of Judgment <input type="checkbox"/> 151 Medicare Act <input type="checkbox"/> 152 Recovery of Defaulted Student Loans - Excl. Veterans <input type="checkbox"/> 153 Recovery of Overpayment of Veteran's Benefits <input type="checkbox"/> 160 Stockholders Suits <input type="checkbox"/> 190 Other Contract <input type="checkbox"/> 195 Contract Product Liability	PERSONAL INJURY <input type="checkbox"/> 310 Airplane <input type="checkbox"/> 315 Airplane Product Liability <input type="checkbox"/> 320 Assault, Libel & Slander <input type="checkbox"/> 330 Federal Employers Liability <input type="checkbox"/> 340 Marine <input type="checkbox"/> 345 Marine Product Liability <input type="checkbox"/> 350 Motor Vehicle <input type="checkbox"/> 355 Motor Vehicle Product Liability <input type="checkbox"/> 360 Other Personal Injury	PERSONAL INJURY <input type="checkbox"/> 362 Personal Injury - Med Malpractice <input type="checkbox"/> 365 Personal Injury - Product Liability <input type="checkbox"/> 368 Asbestos Personal Injury Product Liability	<input type="checkbox"/> 422 Appeal 28 USC 158 <input type="checkbox"/> 423 Withdrawal 28 USC 157	<input type="checkbox"/> 400 State Reapportionment <input type="checkbox"/> 410 Antitrust <input type="checkbox"/> 430 Banks and Banking <input type="checkbox"/> 450 Commerce/ICC Rates/etc <input type="checkbox"/> 460 Deportation <input type="checkbox"/> 470 Racketeer Influenced and Corrupt Organizations <input type="checkbox"/> 810 Selective Service <input type="checkbox"/> 850 Securities/Commodities/Exchange <input type="checkbox"/> 875 Customer Challenge 12 USC 3410 <input type="checkbox"/> 891 Agricultural Acts <input type="checkbox"/> 892 Economic Stabilization Act <input type="checkbox"/> 893 Environmental Matters <input type="checkbox"/> 894 Energy Allocation Act <input type="checkbox"/> 895 Freedom of Information Act <input type="checkbox"/> 900 Appeal of Fee Determination Under Equal Access to Justice <input type="checkbox"/> 950 Constitutionality of State Statutes <input type="checkbox"/> 990 Other Statutory Actions A OR B
A REAL PROPERTY <input type="checkbox"/> 210 Land Condemnation <input type="checkbox"/> 220 Foreclosure <input type="checkbox"/> 230 Rent Lease & Ejectment <input type="checkbox"/> 240 Torts to Land <input type="checkbox"/> 245 Tort Product Liability <input type="checkbox"/> 290 All Other Real Property	A CIVIL RIGHTS <input type="checkbox"/> 441 Voting <input type="checkbox"/> 442 Employment <input type="checkbox"/> 443 Housing, Accommodations <input type="checkbox"/> 444 Welfare <input type="checkbox"/> 440 Other Civil Rights	PRISONER PETITIONS <input type="checkbox"/> 510 Motions to Vacate Sentence HABEAS CORPUS: <input type="checkbox"/> 530 General <input type="checkbox"/> 535 Death Penalty <input type="checkbox"/> 540 Mandamus & Other <input type="checkbox"/> 550 Civil Rights <input type="checkbox"/> 555 Prison Condition	A LABOR <input type="checkbox"/> 610 Agriculture <input type="checkbox"/> 620 Other Food & Drug <input type="checkbox"/> 625 Drug Related Seizure of Property 21 USC 881 <input type="checkbox"/> 630 Liquor Laws <input type="checkbox"/> 640 R.R. & Truck <input type="checkbox"/> 650 Airline Regs <input type="checkbox"/> 660 Occupational Safety/Health <input type="checkbox"/> 690 Other	A PROPERTY RIGHTS <input type="checkbox"/> 820 Copyrights <input type="checkbox"/> 830 Patent <input type="checkbox"/> 840 Trademark
		<input type="checkbox"/> 710 Fair Labor Standards Act <input type="checkbox"/> 720 Labor/Mgmt Relations <input type="checkbox"/> 730 Labor/Mgmt Reporting & Disclosure Act <input type="checkbox"/> 740 Railway Labor Act <input type="checkbox"/> 790 Other Labor Litigation <input type="checkbox"/> 791 Empl Ret Inc Security Act	B SOCIAL SECURITY <input type="checkbox"/> 861 HIA (1395f) <input type="checkbox"/> 862 Black Lung (923) <input type="checkbox"/> 863 DIWC/DIWW (405(g)) <input type="checkbox"/> 864 SSID Title XVI <input type="checkbox"/> 865 RSI (405(g))	FEDERAL TAX SUITS <input type="checkbox"/> 870 Taxes (U.S. Plaintiff or Defendant) <input type="checkbox"/> 871 IRS - Third Party 26 USC 7809

VI. CAUSE OF ACTION (CITE THE U.S. CIVIL STATUTE UNDER WHICH YOU ARE FILING AND WRITE BRIEF STATEMENT OF CAUSE. DO NOT CITE JURISDICTIONAL STATUTES UNLESS DIVERSITY)

35 U.S.C. § 271 Patent Infringement

LENGTH OF TRIAL: 2 days estimated (for both sides to try entire case)

VII. REQUESTED IN COMPLAINT: CHECK IF THIS IS A CLASS ACTION UNDER F.R.C.P. 23

DEMAND \$

CHECK YES only if demanded in complaint:
JURY DEMAND: YES NO

VIII. RELATED CASE(S) IF ANY (See instructions): JUDGE _____ DOCKET NUMBER _____

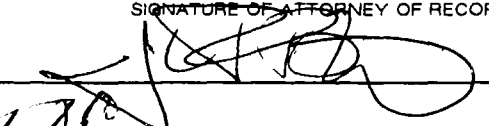
DATE: 9/30/03 SIGNATURE OF ATTORNEY OF RECORD: 

RECEIPT 529195 AMOUNT: 1380 APPLYING IFP: _____ JUDGE: _____ MAG. JUDGE: _____