

IN THE UNITED STATES DISTRICT COURT
FOR THE NORTHERN DISTRICT OF ILLINOIS
EASTERN DIVISION

DOCKETED
JUL 07 2003

SASO GOLF, INC.,)

Plaintiff,)

v.)

CALLAWAY GOLF CO.,)
CALLAWAY GOLF SALES CO., and)
PRO SELECT SPORTS USA)

Defendants.)

03C 4646

JUDGE CASTILLO

Jury Trial Demanded

MAKES THE JUDGE DEMAND

FILED 2:05

03 JUL -3 PM 2:40

CLERK
U.S. DISTRICT COURT

COMPLAINT

Plaintiff Saso Golf, Inc. ("Saso Golf"), by its attorneys, complains of defendants Callaway Golf Co. ("Callaway"), Callaway Golf Sales Co. ("Callaway Golf Sales"), and Pro Select Sports USA ("Pro Select Sports") (collectively, "Defendants") and alleges as follows:

Parties

1. Saso Golf is an Illinois corporation with a principal office located in Chicago, Illinois.
2. On information and belief, Defendant Callaway is a Delaware corporation with a principal place of business located in Carlsbad, California.
3. On information and belief, Defendant Callaway Golf Sales is a California corporation with a registered agent located in Chicago, Illinois. On information and belief, Callaway Golf Sales is a wholly-owned subsidiary of Callaway and sells products, including infringing products in this district.
4. On information and belief, Defendant Pro Select Sports is an Illinois corporation with a principal place of business located in Elmhurst, Illinois.

1-1

Jurisdiction and Venue

5. This action is an action for patent infringement under the laws of the United States, Title 35 of the United States Code, as set forth below.

6. This Court has subject matter jurisdiction over the claims in this action pursuant to 28 U.S.C. §1338(a).

7. Personal jurisdiction and venue are proper in this judicial district pursuant to 28 U.S.C. § 1400 (b) because Defendants reside and do business in this judicial district and because they have committed acts of infringement in this judicial district.

Count I - Patent Infringement

8. Plaintiffs repeat and reallege each and every allegation contained in paragraphs 1 – 7, with the same force and effect as if fully set forth herein.

9. On July 8, 1997, United States Patent No. 5,645,495 entitled "GOLF CLUB," a copy of which is attached as Exhibit A, was duly and legally issued. Saso Golf owns the full right, title and interest in and to United States Patent No. 5,645,495.

10. In violation of 35 U.S.C. § 271, Defendants make, use, offer to sell, sell and/or import products that infringe United States Patent No. 5,645,495.

11. United States Patent No. 5,645,495 was publicly available and on information and belief, Defendants Callaway and Callaway Golf Sales have been fully aware of U.S. Patent No. 5,645,495 since April 1998.

12. Pro Select Sports has been fully aware of U.S. Patent No. 5,645,495 since at least as early as August 2001.

13. On information and belief, with full knowledge of U.S. Patent No. 5,645,495, Defendants willfully continue to make, use, offer to sell, sell and/or import products that infringe

United States Patent No. 5,645,495. Defendants will continue their infringement unless enjoined by this Court.

Relief Sought

WHEREFORE, Plaintiff Saso Golf respectfully requests that the Court grant the following relief:

- a. A preliminary and permanent injunction preventing infringement by the Defendants of U.S. Patent No. 5,645,495;
- b. Damages of lost profits, but in no event less than a reasonable royalty, to the maximum extent permitted by law, for Defendants' past and current infringement of U.S. Patent No. 5,645,495;
- c. An award of treble damages and attorney's fees by reason of Defendants' willful infringement of U.S. Patent No. 5,645,495;
- d. An award of interest, including prejudgment interest;
- e. An assessment of costs and disbursements of this action; and
- f. Such other and further relief as justice and equity may require.

Jury Demand

Plaintiff Saso Golf hereby demands trial by jury.

Respectfully submitted,

SASO GOLF, INC.

By:  One of Its Attorneys

James D. Ryndak #2435942
Mark K. Suri #6199636
RYNDAK & SURI
30 North LaSalle Street
Suite 2630
Chicago, IL 60602
Phone: 312-214-7770
Fax: 312-214-7715



US005645495A

United States Patent [19]

[11] **Patent Number:** 5,645,495

Saso

[45] **Date of Patent:** Jul. 8, 1997

[54] **GOLF CLUB**

[75] **Inventor:** Mitsubishi Saso, Kanzaki-gun, Japan

[73] **Assignee:** Himeji Lodge Hakuba Co., Ltd., Himeji, Japan

[21] **Appl. No.:** 479,142

[22] **Filed:** Jun. 7, 1995

3,625,517	12/1971	Durnack	273/167 F
3,655,188	4/1972	Solheim	473/290
3,751,035	8/1973	Lockwood	473/290
3,759,527	9/1973	Witherspoon	273/175
4,211,416	7/1980	Swanson	.
4,367,878	1/1983	Schmidt	273/175
4,438,931	3/1984	Motomiya	273/167 H
4,471,961	9/1984	Masghati	273/175
4,725,062	2/1988	Kinney	273/175
4,854,581	8/1989	Long	473/290
5,011,151	4/1991	Antonious	473/350
5,242,167	9/1993	Antonious	473/350

Related U.S. Application Data

[63] Continuation of Ser. No. 321,588, Oct. 11, 1994, abandoned, which is a continuation of Ser. No. 962,586, filed as PCT/JP92/00303 Mar. 13, 1992 published as WO92/19327 Nov. 12, 1992, abandoned.

[30] **Foreign Application Priority Data**

May 1, 1991	[JP]	Japan	3-130375
Dec. 21, 1991	[JP]	Japan	3-355888

[51] **Int. Cl.⁶** A63B 53/04

[52] **U.S. Cl.** 473/345; 473/349

[58] **Field of Search** 273/167 R, 168, 273/78, 169, 170, 171, 172, 173, 174, 175, 167 A, 77 A, 77 R, 193 R, 194 R, 194 B, 164.1, 187.4, 186.2; 473/324-350

[56] **References Cited**

U.S. PATENT DOCUMENTS

1,299,014	4/1919	O'Hara	273/175
1,503,291	7/1924	Rimmer	273/169 X
1,524,731	2/1925	Davis	273/175
1,525,148	2/1925	Pickop	273/169
1,657,473	1/1928	Howard	273/175 X
1,671,956	5/1928	Sime	273/169 X
1,683,639	9/1928	Vaile	273/169 X
2,023,885	12/1935	Hinckley	273/175 X
2,395,837	3/1946	Baymiller	273/175
2,683,036	7/1954	Klein	.
3,020,048	2/1962	Carroll	273/175 X
3,068,011	12/1962	Sano	273/169 X
3,419,275	12/1968	Winkleman	273/171
3,595,577	7/1971	Hodge	273/167 G X

FOREIGN PATENT DOCUMENTS

211781	12/1957	Australia	273/167 F
238646	10/1960	Australia	273/167 F
54-116079	8/1979	Japan	.
60-85769	5/1985	Japan	.
61-159961	10/1986	Japan	.
62-59059	4/1987	Japan	.
64-43278	2/1989	Japan	.

Primary Examiner—Sebastiano Passaniti
Attorney, Agent, or Firm—Smith Patent Office

[57] **ABSTRACT**

A golf club for improving the flying distance of a ball overcomes toe-down phenomenon due to pulling of the shaft particularly by a skilled player enjoying a high head speed. The golf club further improves the head speed and the directional stability of a hit ball. The golf club has a center of gravity of the head shifted from the toe end of the shaft end by modifying the head shape to decrease the volume of the head by a certain amount at the toe end on the rear side thereof and to increase the head volume at the shaft end on the rear side by an amount equal to the decreased amount. This will reduce the rotational radius of the head about a vertical line, as a rotational center line, when the golf club is suspended at the upper end of the shaft. Furthermore, with a metal wood club, a head is provided with a face which comprises a spherical face formed in such a manner that the curvature in the transverse width direction becomes substantially equal to that in the vertical width direction.

7 Claims, 8 Drawing Sheets

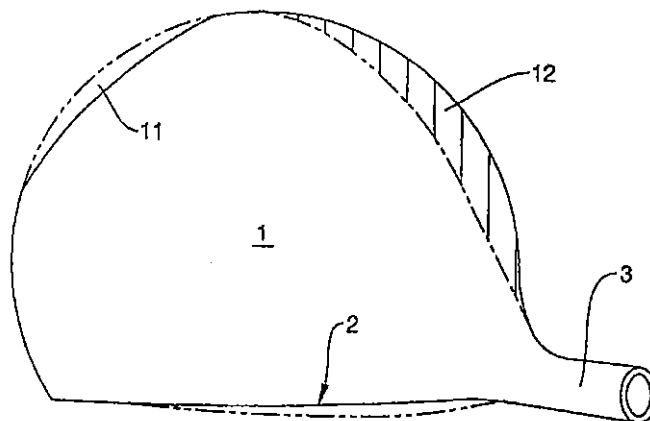

FIG. 1

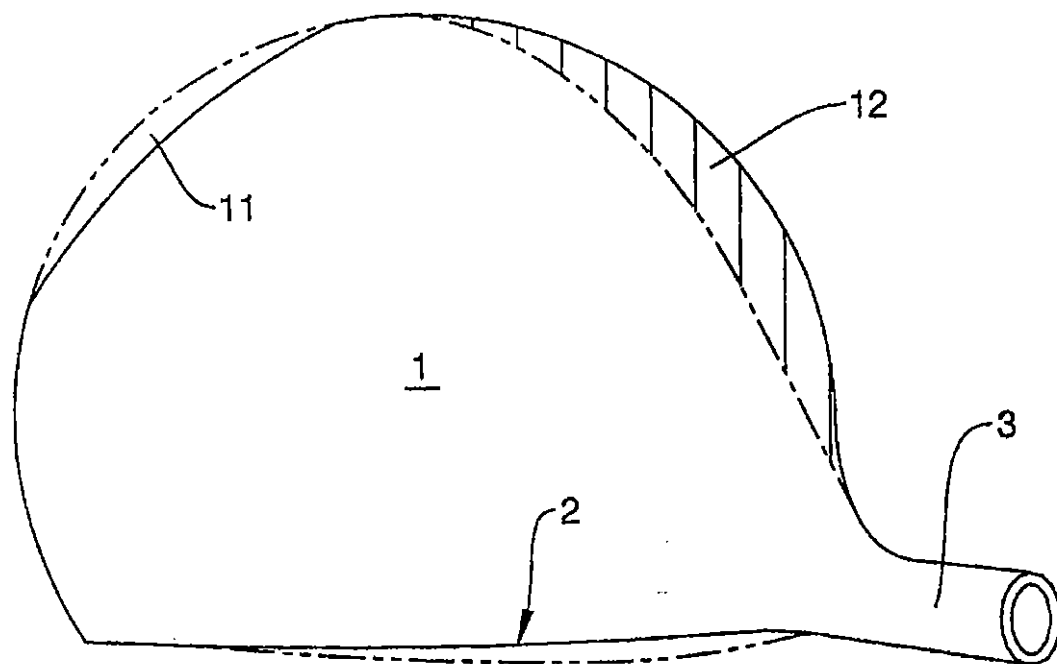
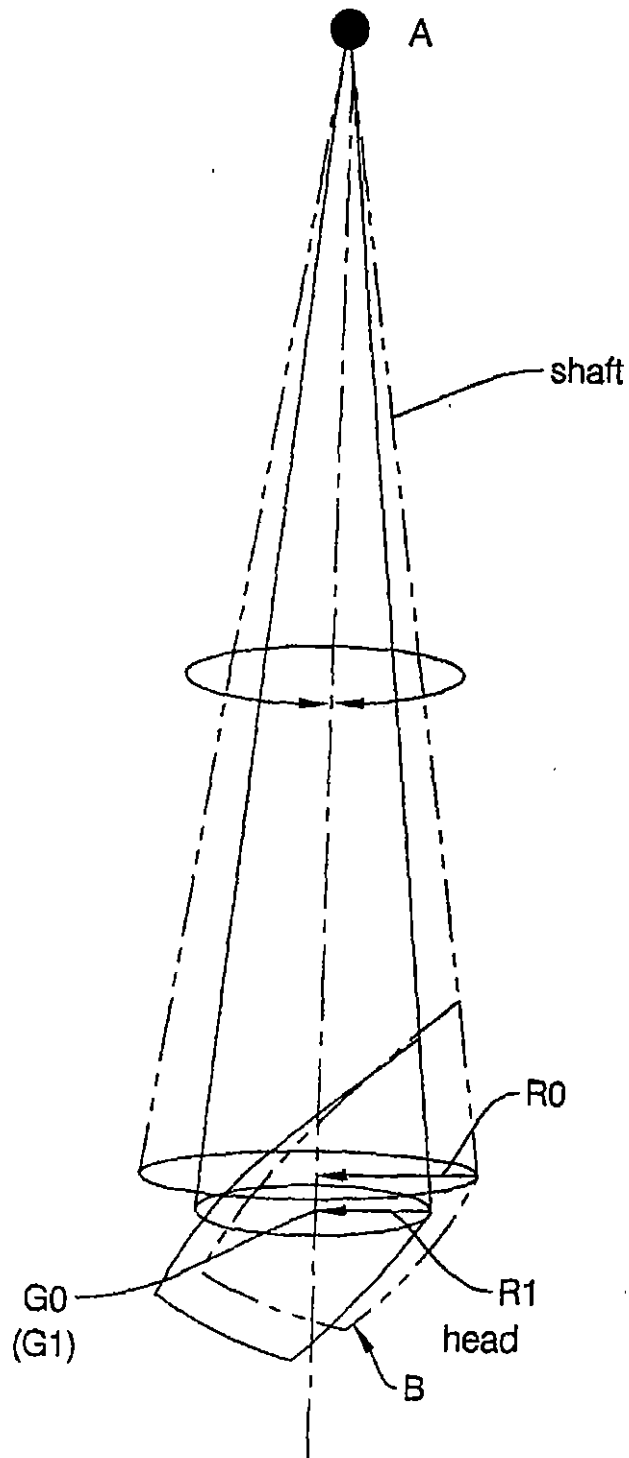

FIG. 2



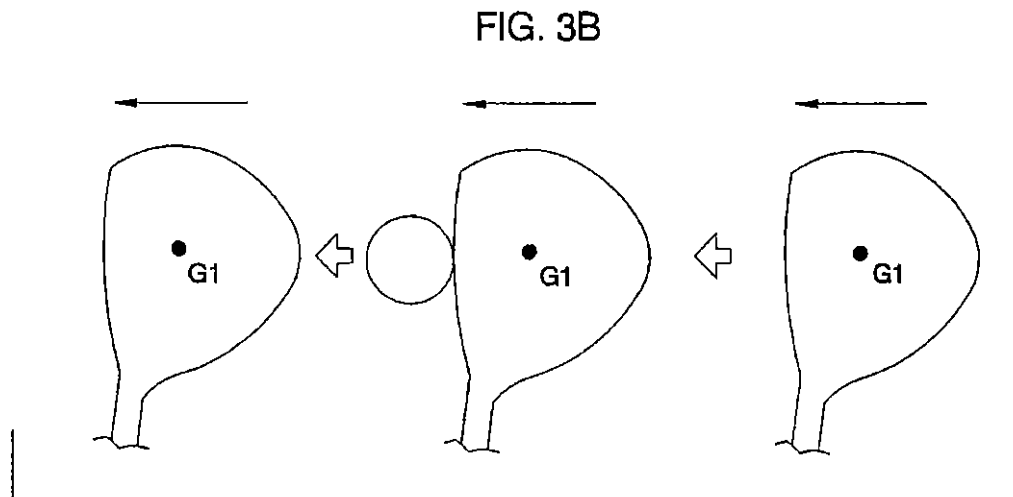
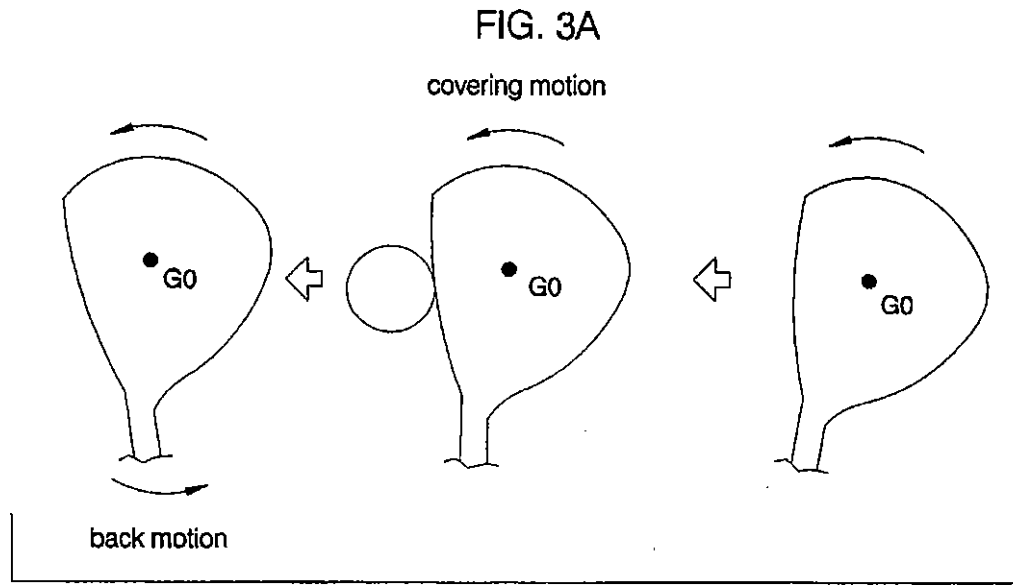

FIG. 4

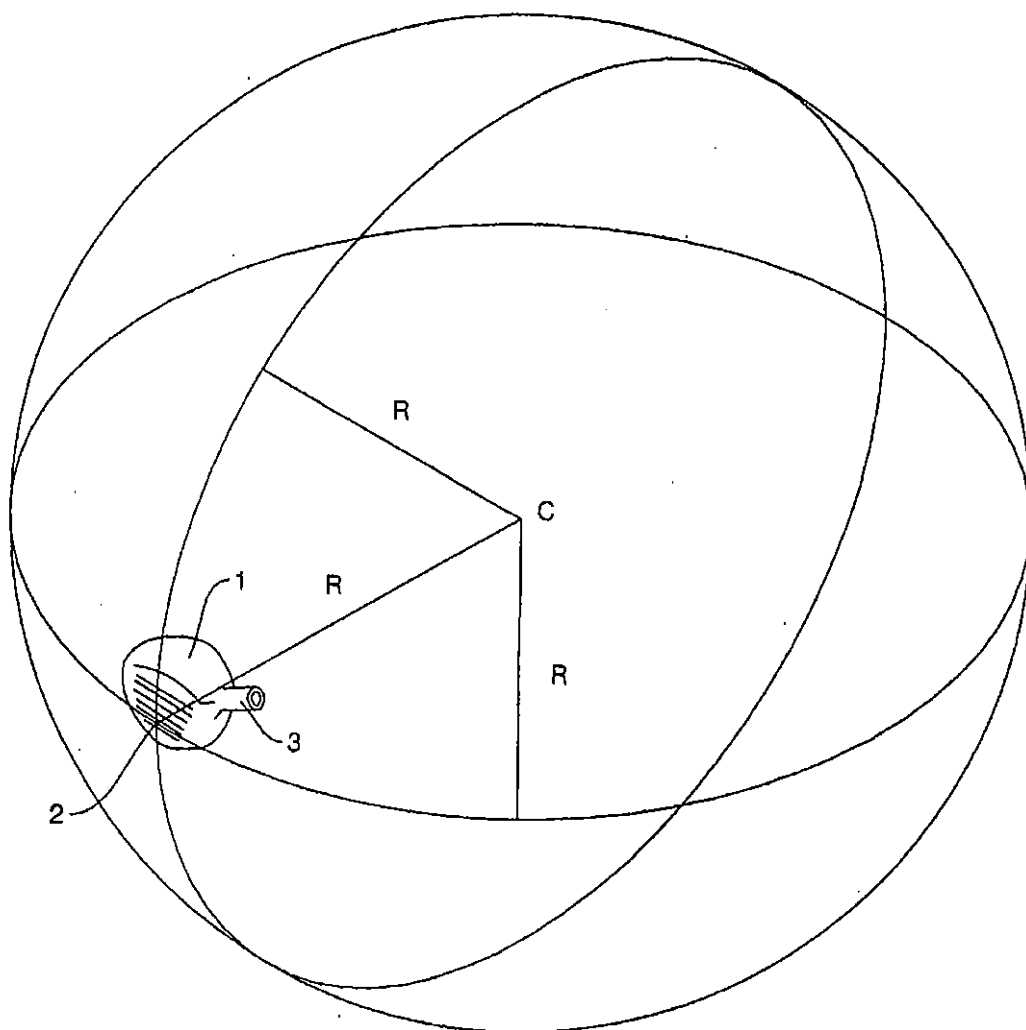

FIG. 5

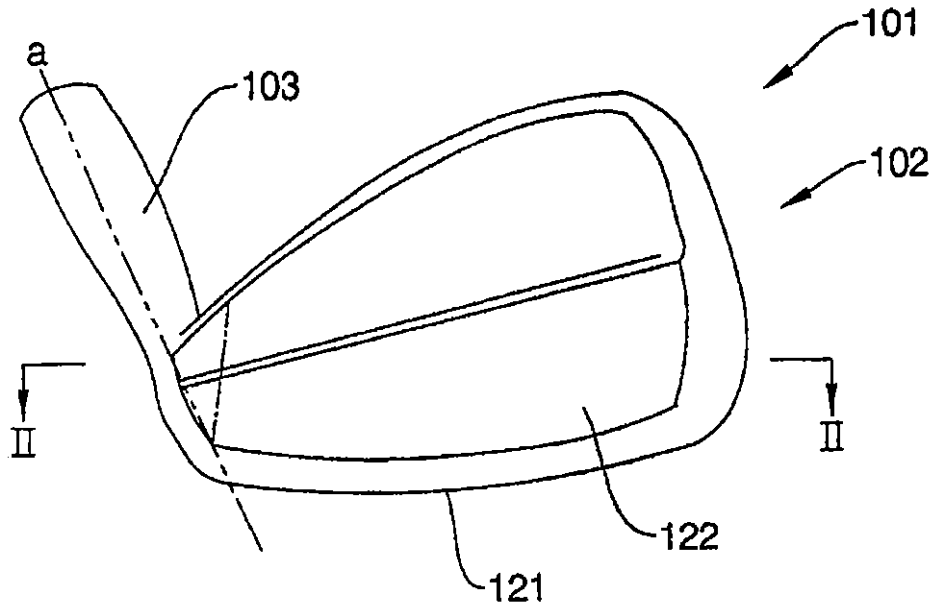

FIG. 6

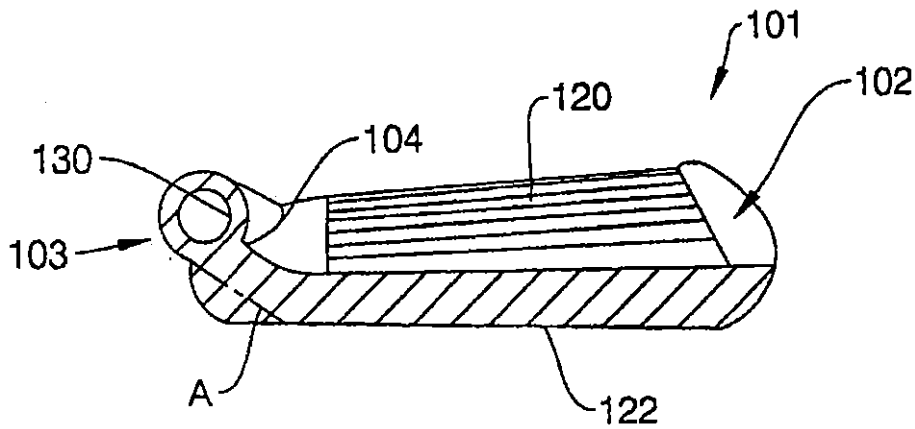
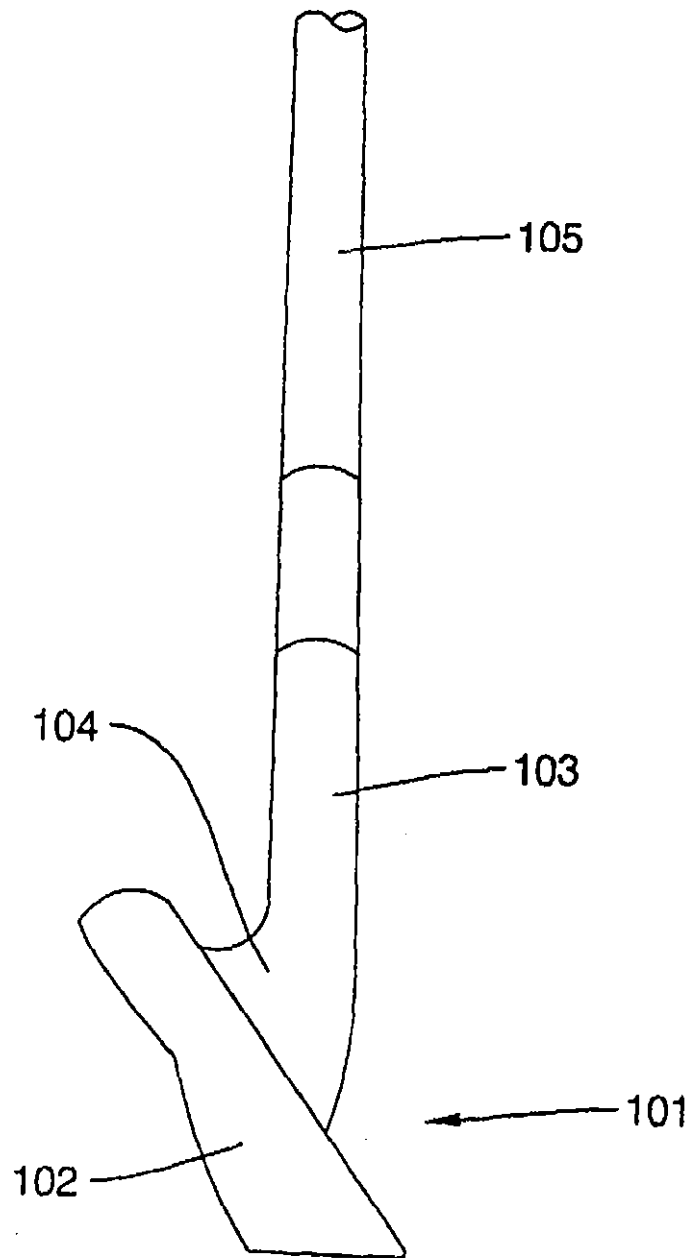

FIG. 7



U.S. Patent

Jul. 8, 1997

Sheet 7 of 8

5,645,495

FIG. 8

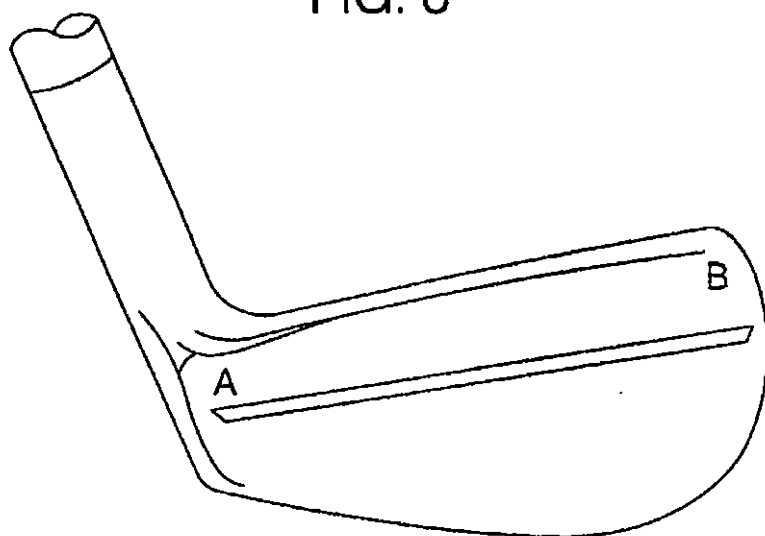
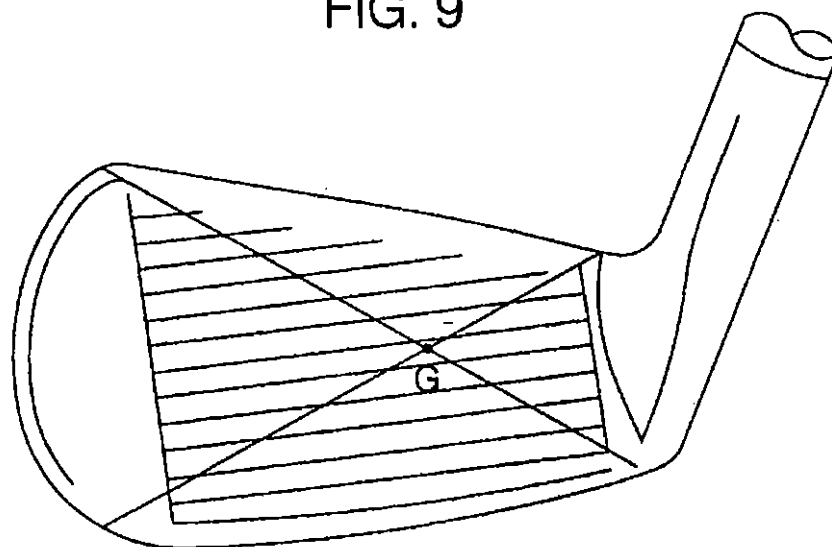

FIG. 9



U.S. Patent

Jul. 8, 1997

Sheet 8 of 8

5,645,495

FIG. 10

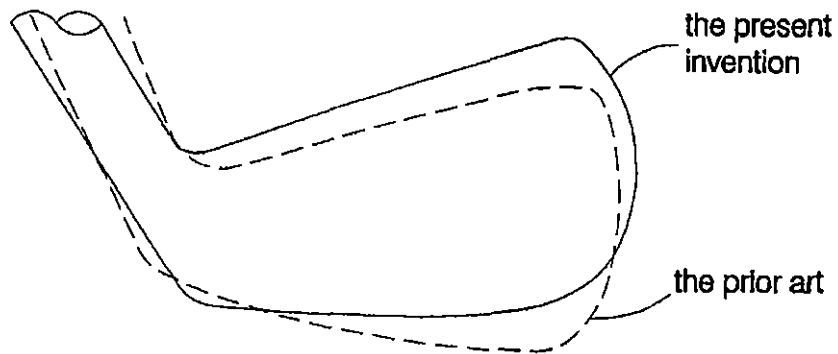

FIG. 11A
the prior art

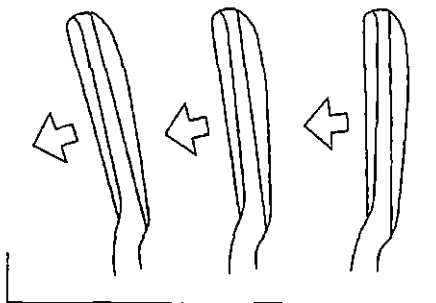
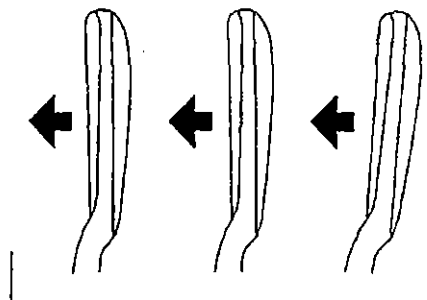

FIG. 11B
the present invention



5,645,495

1

GOLF CLUB

This application is a continuation, of application Ser. No. 08/321,588 filed on Oct. 11, 1994, now abandoned, which is a Continuation application of Ser. No. 07/962,586 filed on Dec. 30, 1992 which was abandoned.

BACKGROUND OF THE INVENTION**1. Field of the Invention**

The present invention relates to a golf club by which the directional stability and flight distance of a shot ball can be improved.

2. Description of the Related Art

In a conventional wooden club, as well as to a metal wood club, a head is in such a shape that, as shown by two dashed line in FIG. 1, it gradually expands from a shaft side to a toe side. The center of gravity of the head is set at a position inclined toward the toe side rather than the center of the projection plane of the head, thereby the head speed of the golf club may be increased at the time of impacting on the ball.

Also in a conventional golf club of an iron type, according to the similar theory, an end of the back side of a club face part is, when seen from a plane, smoothly connected to the hosel, through a neck part, forming a curve (See dashed line A in FIG. 6) and thus the center of gravity of the club is set at a position slightly inclined toward a toe side.

However, when the center of gravity of the head inclines toward the toe side, as shown by two dashed line in FIG. 2, and when the head B is rotated with holding an end A of the club shaft, a radius R_0 of the rotation, with its center line of the rotation positioned at the vertical line made by suspending an upper end of the shaft, increases. Therefore, the metal wood club and the iron club, as shown in FIGS. 3(a) and 11(a), respectively, are apt to cause covering motion (which means the phenomenon that the toe side goes fast than the shaft side as if the toe side rotates around the shaft side) at each head toe side just before impacting.

For the purpose of inhibiting a hook flying of the shot ball, caused by the covering motion, in the metal wood club, as shown by two dashed line in FIG. 1, a head face surface usually has such a shape that the shaft side expands slightly more forward than the toe side. Accordingly, curvature along the transverse direction of the face surface and curvature along longitudinal direction of the face surface are not the same; usually curvature along longitudinal direction is larger than that along the transverse direction.

On the other hand, as shown in FIG. 10, the covering motion is not the only problem in the iron club; that is, the center of gravity of the iron club slightly inclines toward the toe side in the club face part, therefore for advanced golfers whose down swings are faster than those of beginners, a toe down phenomenon, in which the neck part is twisted downwardly by an accelerated motion applied to the head and thus the toe side of the club face part tends to be lowered, resulting in a duff shot.

SUMMARY OF THE INVENTION

Accordingly, for the purpose of overcoming the defects of the conventional club head, the inventor, as a result of his sharp research, has converted the basic concept of designing the club head to a new one in order to provide a golf club head by which improvement in the directional stability and flight distance of the shot ball can be realized. That is the object of the present invention.

2

The present invention has been completed on the inventive concept that due to the property of the sling motion of the club head round the gravity center thereof, in which a heavier part goes forward and a lighter part does not catch up with the heavier part in a manner that the heavier part and the lighter part rotate around the gravity center axis, the conventional club head is subjected not only to the above-mentioned covering movement but also to a pull-back phenomenon in the shaft side as a reaction of the covering movement, accordingly resulting in substantial decrease of the speed of the head. The present invention is, therefore, to provide a golf club which head is formed in such a manner that the amount of a shaft side is increased as much as the amount of a head toe side is decreased so as to shift the center of gravity of the head toward the shaft side and a radius of a rotation, with its center line of the rotation positioned at a vertical line made by suspending an upper end of a shaft, is decreased.

Mere shift of the center of gravity of the head toward the shaft side is not enough to overcome the covering motion of the head; at the same time, the weight balance of the head must be maintained. Therefore, it is advantageous to increase the amount of the shaft side in the head as much as that of the toe side decreases so as to maintain the weight balance of the head. Due to this, the center of gravity of the head usually inclines toward the shaft area by the amount having been shifted.

According to the present invention, as shown by solid line in FIG. 2, since the center of gravity of the head inclines toward the shaft side, when the head is rotated by holding the end of the club shaft, the radius SLAYING of the rotation is smaller than the conventional radius R_0 of the rotation. Moreover due to the increased amount of the shaft side, with use of the sling motion in which the heavier part tends to go forward and the lighter part tends to be pulled backward just before impact, as shown in FIG. 3(b), it is difficult to cause the covering motion apt to take place in the toe side and the draw phenomenon apt to take place in the shaft side, which results in the improvement in the speed of the head upon giving the impact.

In applying the present invention to a metal wood club, the curvatures along the transverse direction and along the longitudinal direction of the face surface are substantially the same. Since the flight direction of the shot golf ball is dominated by both curvatures along the transverse direction and along the longitudinal direction of the face surface of a point where the impact is given, when the curvatures are not the same, the flight direction is not controlled to a desired direction. In the present invention, however, the covering motion of the head at the time of the impact is inhibited by shifting the center of gravity of the head toward the shaft side, resulting in the head face surface is formed by a sphere having substantially the same curvatures along both directions of the face surface, which spherical face is most suitable for giving an impact causing the shot ball controlled. Moreover, since it is difficult to cause the covering motion of the head upon giving an impact, the shot ball tends to direct to the extension of the line connecting the center C of spherical body defining the spherical face and the position where the impact was given, by which superior directional stability of the shot ball is ensured.

In applying the present invention to an iron club, it is preferable to form a back side 122 of a club face part 102 by extending the back side 122 until it passes through the center axis (a) of the hosel part 103 (See FIG. 6), and moreover it is preferable to increase thickness A of the back side 122 by shifting a part of the weight of the toe side B (See FIG. 8).

5,645,495

3

Due to this, although the design is out of the conventional common knowledge in the light of the conventional toe-heel balance, the center of gravity is located at, or almost at the intersection point of diagonals passing across the club face part, by which good balance is maintained, return of the toe in hitting a ball is suppressed by 70% and the cause for duffing can be solved (See FIG. 11). Therefore secure down strokes can be ensured. Moreover in light of the design, thickness of a blade can be increased, by which sufficient spinning shot ball can be made.

Further, since the center of gravity is located at, or almost at the intersection point of diagonals passing across the club face part, different from the conventional iron, a toe down phenomenon apt to take place upon giving an impact can be overcome (See FIG. 10) and the weight distribution suitable for the motion going in and out from a heel is completed, resulting in prevention of mistakes caused by duffing.

In the present invention, when the club face part 2 is designed so as to slightly open by about 1.5° against the ball upon addressing, the defect of the conventional club, in which the head easily turns after the impact and therefore golfers are apt to duff (See FIG. 11(a)), can be overcome. Namely, an impact is given in a slightly open position and immediately after this, the position becomes square and then the head turns little by little, which makes the shot ball fly in a high draw trajectory (See FIG. 11(b)).

Further scope of applicability of the present invention will become apparent from the detailed description given hereinafter. However, it should be understood that the detailed description and specific examples, while indicating preferred embodiments of the invention, are given by way of illustration only, since various changes and modifications within the spirit and scope of the invention will become apparent to those skilled in the art from this detailed description.

BRIEF DESCRIPTION OF THE DRAWINGS

The present invention will become more fully understood from the detailed description given hereinbelow and the accompanying drawings which are given by way of illustration only, and thus are not limitative of the present invention.

FIG. 1 is a plan view comparing the plane shape of a metal head according to the present invention with that of a conventional metal head.

FIG. 2 is a comparative view showing sling motions of wooden clubs with the metal head according to the present invention and with the conventional metal head.

FIG. 3(a) is an explanatory view showing motion of the conventional metal head before and after an impact.

FIG. 3(b) is an explanatory view showing motion of the metal head according to the present invention before and after an impact.

FIG. 4 is a perspective view showing the idea of designing a face surface of the metal head according to the present invention.

FIG. 5 is a rear view showing a head part of an iron club according to the present invention.

FIG. 6 is a sectional view along line II--II in FIG. 5.

FIG. 7 is a front view showing the club according to the present invention.

FIG. 8 is a rear view showing an iron club according to another example of the present invention.

FIG. 9 is a front view showing a position of the center of gravity according to the weight distribution of the present invention.

4

FIG. 10 is a comparative explanatory view showing a toe-down phenomenon in a club according to the present invention (solid line) and in a conventional club.

FIG. 11 is a comparative explanatory view showing a covering motion in an iron club according to the present invention (b) and in a conventional club (a).

DETAILED DESCRIPTION OF THE PREFERRED EMBODIMENTS

The present invention will now be explained in detail, in which the present invention is applied to a metal wood club.

FIG. 1 is a plan view illustrating a projected plane of a metal head according to the present invention, comparing with a conventional metal head. A metal head 1 is a hollow casting, having a spherical face 2 and a hosel part 3 connecting with an unshown shaft. The weight distribution 11 of a toe side is shifted to the back of a shaft side 12 and expanded (See an extent of oblique line). On the whole, the distribution of the amount is not symmetrical, but leans toward the shaft area rather than the toe area. Therefore besides the center of gravity of the head shifts from G0 to the shaft side G1, the distribution of the amount in the shaft side is increased. As a result, the superior weight distribution which, at the moment of giving an impact, suppresses the covering motion in the toe side and the draw phenomenon in the shaft side, can be obtained.

As for the face surface 2, as shown in FIG. 4, the curvature R along the transverse direction and the curvature R along the longitudinal direction are unified and the face 2 surface is so designed that it forms a part of a sphere with radius R round a center C as illustrated. The hosel part 3 obliquely protrudes upward from a position adjacent to the face surface translated in parallel to the center of the sphere. The loft angle of the face surface generally falls on the range from about 9° – 12° and both curvatures along the transverse and longitudinal directions of the face are selected from the range from 9 – $12R$ so that they are the same. Use of such a golf club makes a golf ball and the face surface collide with each other at the time of impact as if a small ball and a large ball collided with each other and the shot ball is directed to the line extending a radius connecting the spherical center C and the position where the impact was given.

Now the present invention will be explained, in which it is applied to an iron club head.

FIGS. 5 to 7 illustrate an iron golf club according to an example of this invention. A club head 101 is formed by integrally connecting a club face part 102 and a hosel part 103 at a neck part 104. The club head 101 is integrally manufactured with use of an iron material or a copper material by means of forging or casting and polished for finishing.

A fixed hole 130 is formed along the longitudinal direction of the hosel part 103. A shaft 105 is engaged with and fixed to the fixed hole 130 and at the upper side of the shaft, a grip (not shown) is provided.

The club face part 102 comprises a face 120 made open by 1.5° from a square, a sole 121 and a back side 122. As shown in FIG. 5, the back side 122 is formed in such a manner that the back side 122 is extended to a position passing through the center axis (a) of the hosel part 103 and connected to the hosel part 103 through an end surface. The thickness of the back side 122 of the club face part 102, therefore, is increased and compared with the shape of a conventional club head, the neck part is made much smaller. As a result, the weight of the neck part is increased and, as shown in FIG. 9, the center of gravity of the club head is located at or adjacent to an intersection point of diagonals of the face part.

5,645,495

5

Accordingly, when a golfer with this club addresses, even though the club face part 102 is placed in a square position, it looks slightly open. The back side 122 of the club face part 102 is extended to a position passing across the center axis (a) of the hosel part 103. The neck part swells and further the center of gravity of the club face part 102 is positioned at the intersection point of the diagonals and slightly inclines toward a heel side to stabilize the club face part 102. When the club is swung under these conditions, it is easy for a golfer to give an impact to a ball in a square position and fly the ball in a straight direction without a hook or a slice. Moreover even when advanced golfers swing downward at a high speed, since good rigidity around the hosel part 103 is given and the center of gravity of the club face part 102 is located at the intersection point of the diagonals so as to slightly incline toward the heel side, a toe-down phenomenon hardly takes place and it results in a smooth impact without duffing.

The invention being thus described, it will be obvious that the same may be varied in many ways. Such variations are not to be regarded as a departure from the spirit and scope of the invention, and all such modifications as would be obvious to one skilled in the art are intended to be included within the scope of the following claims.

What is claimed is:

1. A golf club comprising:

a metallic wood type head having a heel side and a toe side, the mass of the heel side being increased as much as the mass of the toe side of the head is decreased so as to shift the center of gravity of the head toward the heel side, the head having a portion of a surface shaped such that the curvature of the surface approximates the curvature of a sphere, the portion of the surface of the head having substantially the same curvatures along the transverse direction thereof as along a longitudinal direction thereof;

a shaft having an upper end and lower end, the lower end being connected to the head at the heel side; and

6

said metallic wood type head further comprising a toe, a heel and a back side profile shape extending from the toe side to the heel side, said back side profile shape between the toe and a most rearwardly point of said metallic wood type head having a radius of curvature that is larger than the radius of curvature of said back side profile shape between the most rearwardly point of said metallic wood type head and the heel.

2. The golf club as claimed in claim 1, wherein the head is a hollow casting with a hosel part to which the shaft is connected.

3. The golf club as claimed in claim 2, wherein the hosel part obliquely protrudes upwardly from a position adjacent a face surface of the head.

4. The golf club as claimed in claim 3, wherein the face surface of the head has a loft angle of 9° to 12°.

5. The golf club as claimed in claim 1, wherein the head has a face surface with a loft angle of 9° to 12°.

6. The golf club as claimed in claim 1, wherein the center of gravity of the head is located approximately in a geometric center of the head.

7. A golf club comprising:

a metallic wood type head including a cylindrical hosel portion formed integrally therewith;

said metallic wood type head having a heel side and a toe side, said metallic wood type head having a hitting surface extending from the toe side to said heel side, the hitting surface having substantially the same curvature along a transverse direction as a longitudinal direction,

said metallic wood type head further comprising a toe, a heel, and a back side profile shape extending from the toe side to the heel side, said back side profile shape between the toe and a most rearwardly point of said metallic wood type head having a radius of curvature that is larger than the radius of curvature of said back side profile shape between the most rearwardly point of said metallic wood type head and the heel.

* * * * *

UNITED STATES DISTRICT COURT
NORTHERN DISTRICT OF ILLINOIS

1

Civil Cover Sheet

This automated JS-44 conforms generally to the manual JS-44 approved by the Judicial Conference of the United States in September 1974. The data is required for the use of the Clerk of Court for the purpose of initiating the civil docket sheet. The information contained herein neither replaces nor supplements the filing and service of pleadings or other papers as required by law. This form is authorized for use only in the Northern District of Illinois.

DOCKETED
JUL 07 2003

Plaintiff(s): **Saso Golf, Inc.**

Defendant(s): **Callaway Golf Co., Callaway Golf Sales Co., and Pro Select Sports USA**

County of Residence: **Cook County**

County of Residence:

Plaintiff's Atty: **See Attachment**

Defendant's Atty:

II. Basis of Jurisdiction: **3. Federal Question (U.S. not a party)**

III. Citizenship of Principal Parties (Diversity Cases Only)

Plaintiff:- **N/A**
Defendant:- **N/A**

030 4646

FILED-ED5
03 JUL -3 PM 2:43
CLERK
U.S. DISTRICT COURT

JUDGE CASTILLO

IV. Origin : **1. Original Proceeding**

V. Nature of Suit: **830 Patent**

MAGISTRATE JUDGE DENLOW

VI. Cause of Action: **35 U.S.C. Sec. 271 (Action for Patent Infringement)**

VII. Requested in Complaint

Class Action: **No**
Dollar Demand:
Jury Demand: **Yes**

VIII. This case **IS NOT** a refiling of a previously dismissed case.

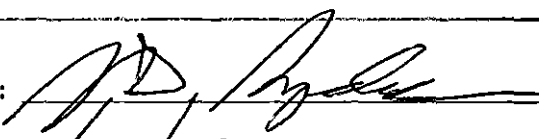
Signature: 
Date: 7/3/03

If any of this information is incorrect, please go back to the Civil Cover Sheet Input form using the *Back* button in your browser and change it. Once correct, print this form, sign and date it and submit it with your new civil action. **Note: You may need to adjust the font size in your browser display to make the form print properly.**
Revised: 06/28/00

1-2

**IN THE UNITED STATES DISTRICT COURT
FOR THE NORTHERN DISTRICT OF ILLINOIS
EASTERN DIVISION**

SASO GOLF, INC.,)	
)	
Plaintiff,)	
)	
v.)	
)	
CALLAWAY GOLF CO.,)	Civil Action No.
CALLAWAY GOLF SALES CO. and)	
PRO SELECT SPORTS USA)	
)	
Defendants.)	

ATTACHMENT TO CIVIL COVER SHEET

Plaintiff's Attorneys:

James D. Ryndak, #2435942
Mark K. Suri, #6199636
RYNDAK & SURI
30 North LaSalle
Suite 2630
Chicago, IL 60602
Phone: 312-214-7770
Fax: 312-214-7715

**UNITED STATES DISTRICT COURT
NORTHERN DISTRICT OF ILLINOIS**

In the Matter of

EASTERN DIVISION

Saso Golf, Inc., Plaintiff

v.

Callaway Golf Co., Callaway Golf Sales Co.,
and Pro Select Sports USA, Defendants.

Case Number:

030 4646

APPEARANCES ARE HEREBY FILED BY THE UNDERSIGNED AS ATTORNEY(S) FOR:

Saso Golf, Inc., Plaintiff

JUDGE CASTILLO

DOCKETED

MAGISTRATE JUDGE DENLOW

JUL 07 2003

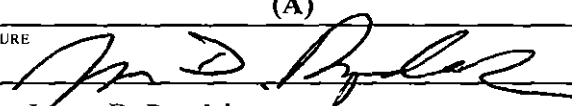
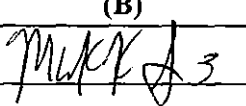
(A)		(B)	
SIGNATURE 		SIGNATURE 	
NAME James D. Ryndak		NAME Mark K. Suri	
FIRM Ryndak & Suri		FIRM Ryndak & Suri	
STREET ADDRESS 30 N. LaSalle Street, Suite 2630		STREET ADDRESS 30 N. LaSalle Street, Suite 2630	
CITY/STATE/ZIP Chicago, IL 60602		CITY/STATE/ZIP Chicago, IL 60602	
TELEPHONE NUMBER 312-214-7770	FAX NUMBER 312-214-7715	TELEPHONE NUMBER 312-214-7770	FAX NUMBER 312-214-7715
E-MAIL ADDRESS Ryndak@ryndaksuri.com		E-MAIL ADDRESS Suri@ryndaksuri.com	
IDENTIFICATION NUMBER (SEE ITEM 4 ON REVERSE) 2435942		IDENTIFICATION NUMBER (SEE ITEM 4 ON REVERSE) 6199636	
MEMBER OF TRIAL BAR?	YES <input checked="" type="checkbox"/> NO <input type="checkbox"/>	MEMBER OF TRIAL BAR?	YES <input checked="" type="checkbox"/> NO <input type="checkbox"/>
TRIAL ATTORNEY?	YES <input checked="" type="checkbox"/> NO <input type="checkbox"/>	TRIAL ATTORNEY?	YES <input checked="" type="checkbox"/> NO <input type="checkbox"/>
		DESIGNATED AS LOCAL COUNSEL?	YES <input type="checkbox"/> NO <input type="checkbox"/>
(C)		(D)	
SIGNATURE		SIGNATURE	
NAME		NAME	
FIRM		FIRM	
STREET ADDRESS		STREET ADDRESS	
CITY/STATE/ZIP		CITY/STATE/ZIP	
TELEPHONE NUMBER	FAX NUMBER	TELEPHONE NUMBER	FAX NUMBER
E-MAIL ADDRESS		E-MAIL ADDRESS	
IDENTIFICATION NUMBER (SEE ITEM 4 ON REVERSE)		IDENTIFICATION NUMBER (SEE ITEM 4 ON REVERSE)	
MEMBER OF TRIAL BAR?	YES <input type="checkbox"/> NO <input type="checkbox"/>	MEMBER OF TRIAL BAR?	YES <input type="checkbox"/> NO <input type="checkbox"/>
TRIAL ATTORNEY?	YES <input type="checkbox"/> NO <input type="checkbox"/>	TRIAL ATTORNEY?	YES <input type="checkbox"/> NO <input type="checkbox"/>
DESIGNATED AS LOCAL COUNSEL?	YES <input type="checkbox"/> NO <input type="checkbox"/>	DESIGNATED AS LOCAL COUNSEL?	YES <input type="checkbox"/> NO <input type="checkbox"/>

FILED
 03 JUL - 3 PM 2:13
 CLERK
 U.S. DISTRICT COURT

13