

1 Michael J. Wise, Bar No. 143501
Mwise@perkinscoie.com
2 Lauren Sliger, Bar No. 213880
LSliger@perkinscoie.com
3 John E. Peterson, Bar No. 197978
JEPeterson@perkinscoie.com
4 PERKINS COIE LLP
1888 Century Park E., Suite 1700
5 Los Angeles, CA 90067-1721
Telephone: 310.788.9900
6 Facsimile: 310.788.3399

7 Attorneys for Plaintiff
RUYAN INVESTMENT (HOLDINGS) LIMITED
8

2011 JAN 26 PM 3:42
CLERK U.S. DISTRICT COURT
CENTRAL DISTRICT OF CALIF.
LOS ANGELES

FILED

9 UNITED STATES DISTRICT COURT
10 CENTRAL DISTRICT OF CALIFORNIA

11
12 RUYAN INVESTMENT
(HOLDINGS) LIMITED,
13 a British Virgin Islands company,

14 Plaintiff,

15 v.

16 SMOKING EVERYWHERE, INC., a
Florida corporation; INSTEAD, LLC, a
17 Nevada limited liability company;
BLEC, LLC, a Nevada limited liability
18 company; SOTTERA, INC., a Nevada
corporation,

19 Defendants.
20

Case No. CV11-0367 GAF (FFMx)
FIRST
**AMENDED COMPLAINT FOR
PATENT INFRINGEMENT**

DEMAND FOR JURY TRIAL

21 Plaintiff Ruyan Investment (Holdings) Limited (“Ruyan”), by and though its
22 attorneys, files this amended complaint against Defendants Smoking Everywhere,
23 Inc., Instead, LLC, BLEC, LLC, and Sottera, Inc., (collectively “Defendants”) and,
24 demanding a trial by jury, hereby alleges with knowledge with respect to its own
25 acts and upon information and belief with respect to all others, as follows:
26
27
28

1
2
3
4
5
6
7
8
9
10
11
12
13
14
15
16
17
18
19
20
21
22
23
24
25
26
27
28

JURISDICTION AND VENUE

- 1. This is a civil action for patent infringement arising under the patent laws of the United States, 35 U.S.C. §§ 101, et seq., and in particular § 271.
- 2. This Court has subject matter jurisdiction over this patent infringement action under 28 U.S.C. §§ 1331, 1332, and 1338(a).
- 3. This Court has personal jurisdiction over Defendants because they regularly conduct and solicit business in California and derive substantial revenue from goods used or services rendered in California and within this judicial district.
- 4. Venue lies in this judicial district pursuant to 28 U.S.C. §§ 1391(b) and (c), and 1400(b).

PARTIES

- 5. Plaintiff Ruyan (“Plaintiff”) is a company organized and existing under the laws of British Virgin Islands and has its principle place of business at 15F, Hong Kong and Macau Building, 156-157 Connaught Rd., Central, Hong Kong, S.A.R.
- 6. Defendant Smoking Everywhere, Inc. is a corporation organized and existing under the laws of the State of Florida, having its principal place of business at 5600 NW 102nd Avenue, Suite A, Sunrise, Florida 33351, USA, and doing business in this judicial district, including business related to the claims asserted in this Complaint.
- 7. Defendant Instead, LLC is a limited liability company organized and existing under the laws of the State of Nevada, having its principal place of business at 9801 Fall Creek Rd. #245, Indianapolis, Indiana 46256, USA, and doing business in this judicial district, including business related to the claims asserted in this Complaint.
- 8. Defendant BLEC, LLC is a limited liability company organized and existing under the laws of the State of Nevada, having its principal place of business at 401 N. Tryon St., Suite 100, Charlotte, North Carolina 28202, USA, and

1 doing business in this judicial district, including business related to the claims
2 asserted in this Complaint.

3 9. Defendant Sottera, Inc., is a corporation organized and existing under
4 the laws of the State of Nevada, having its principal place of business at 15455
5 North Greenway Hayden Loop Road, Scottsdale, Arizona 85260, USA, and doing
6 business under the tradename NJOY, including business in this judicial district
7 related to the claims asserted in this Complaint.

8
9

FIRST CAUSE OF ACTION

10 (Infringement of U.S. Patent No. 7,832,410)

11 10. Ruyan repeats, realleges and incorporates by reference, as though fully
12 set forth herein, the allegations contained in paragraphs 1-9 above.

13 11. Ruyan is the owner, by proper assignment, of United States Patent No.
14 7,832,410 (“the 410 Patent”). The ’410 Patent was duly and legally issued by the
15 United States Patent Office on November 16, 2010 and is valid and subsisting and
16 in full force and effect. A copy of the ’410 Patent is attached to the Complaint as
17 **Exhibit A.**

18 12. Defendants have each infringed, contributed to the infringement of,
19 and/or actively induced infringement of the ’410 Patent by, themselves and/or
20 through their agents, unlawfully and wrongfully making, using, importing, offering
21 to sell, and/or selling electronic cigarette (a.k.a. “e-cigarette”) products embodying
22 one or more of the inventions claimed in the ’410 Patent, within and/or from the
23 United States without permission or license from Ruyan, and will continue to do so
24 unless enjoined by this Court.

25 13. Defendant Smoking Everywhere, Inc. has infringed, contributed to the
26 infringement of, and/or actively induced infringement of the ’410 Patent by,
27 themselves and/or through their agents, unlawfully and wrongfully making, using,
28 importing, offering to sell, and/or selling electronic cigarette products, such as the

1 Smoking Everywhere Gold One Edition e-cigarette kit, that embody one or more of
2 the inventions claimed in the '410 Patent.

3 14. Defendant Instead, LLC has infringed, contributed to the infringement
4 of, and/or actively induced infringement of the '410 Patent by, themselves and/or
5 through their agents, unlawfully and wrongfully making, using, importing, offering
6 to sell, and/or selling electronic cigarette products, such as the INSTEAD e-
7 cigarette kit, that embody one or more of the inventions claimed in the '410 Patent.

8 15. Defendant BLEC, LLC has infringed, contributed to the infringement
9 of, and/or actively induced infringement of the '410 Patent by, themselves and/or
10 through their agents, unlawfully and wrongfully making, using, importing, offering
11 to sell, and/or selling electronic cigarette products, such as the blu e-cigarette kit,
12 that embody one or more of the inventions claimed in the '410 Patent.

13 16. Defendant Sottera, Inc., has infringed, contributed to the infringement
14 of, and/or actively induced infringement of the '410 Patent by, themselves and/or
15 through their agents, unlawfully and wrongfully making, using, importing, offering
16 to sell, and/or selling electronic cigarette products, such as the NJOY NCIG e-
17 cigarette, that embody one or more of the inventions claimed in the '410 Patent.

18 17. Defendants' continuing infringement has inflicted and, unless
19 restrained by this court, will continue to inflict great and irreparable harm upon
20 Ruyan. Ruyan has no adequate remedy at law. Ruyan is entitled to preliminary and
21 permanent injunctions enjoining Defendants from engaging in further acts of
22 infringement.

23 18. As a direct and proximate result of the foregoing acts of Defendants,
24 Ruyan has suffered, and is entitled to, monetary damages in an amount not yet
25 determined. Ruyan is also entitled to its costs of suit and interest.

26 19. By way of this patent infringement complaint, Defendants now have
27 notice and knowledge of the '410 Patent and of Ruyan's rights therein.

28

1 20. Defendants' continuing acts of infringement, if any, are in conscious
2 and willful disregard for Ruyan's rights, and the resulting damages to Ruyan is such
3 as to warrant the trebling of damages to provide just compensation.

4 **PRAYER FOR RELIEF**

5 WHEREFORE, Ruyan respectfully demands that this Court:

6 A. Enter a judgment that Defendants have infringed the '410 Patent;

7 B. Enter an order preliminarily and permanently enjoining Defendants,
8 their officers, agents, servants and employees, and any others acting in concert with
9 any of them, from directly or indirectly infringing the '410 Patent;

10 C. Award Ruyan damages resulting from Defendants' patent infringement
11 pursuant to 35 U.S.C. § 284;

12 D. Find that Defendants' continuing patent infringement has been willful
13 and increase damages awarded to Ruyan three times the amount assessed pursuant
14 to 35 U.S.C. § 284;

15 E. Find this to be an exceptional case and award Ruyan attorneys' fees
16 pursuant to 35 U.S.C. § 285;

17 F. Award Ruyan prejudgment interest and post-judgment interest on the
18 damages and award Ruyan costs; and

19 G. Award Ruyan such other and further relief, in law or in equity, as the
20 Court deems just, equitable or appropriate.

21 DATED: January 25, 2011

PERKINS COIE LLP

22
23 By: 
24 John E. Peterson, Bar No. 197978
JEPeterson@perkinscoie.com

25 Attorneys for Plaintiff
26 RUYAN INVESTMENT
27 (HOLDINGS) LIMITED
28

1
2
3
4
5
6
7
8
9
10
11
12
13
14
15
16
17
18
19
20
21
22
23
24
25
26
27
28

DEMAND FOR JURY TRIAL

Plaintiff hereby demands a trial by jury of all issues triable by a jury.

DATED: January 25, 2011

PERKINS COIE LLP

By: 
John E. Peterson, Bar No. 197978
JEPeterson@perkinscoie.com

Attorneys for Plaintiff
RUYAN INVESTMENT
(HOLDINGS) LIMITED

Exhibit A



US007832410B2

(12) **United States Patent**
Hon

(10) **Patent No.:** US 7,832,410 B2
 (45) **Date of Patent:** Nov. 16, 2010

(54) **ELECTRONIC ATOMIZATION CIGARETTE**

FOREIGN PATENT DOCUMENTS

(75) Inventor: **Lik Hon, Hong Kong (CN)**

CA 2562581 A1 10/2005

(73) Assignee: **Best Partners Worldwide Limited, Tortola (VG)**

(Continued)

(*) Notice: Subject to any disclaimer, the term of this patent is extended or adjusted under 35 U.S.C. 154(b) by 600 days.

OTHER PUBLICATIONS

(21) Appl. No.: **10/587,707**

Australian Patent Office Examination Report for SG 200505930-8 dated May 4, 2006 (3 pages).

(22) PCT Filed: **Mar. 18, 2005**

(Continued)

(86) PCT No.: **PCT/CN2005/000337**

Primary Examiner—Eric Hug
 Assistant Examiner—Anthony J Calandra
 (74) Attorney, Agent, or Firm—Perkins Coie LLP

§ 371 (c)(1),
 (2), (4) Date: **Mar. 9, 2007**

(87) PCT Pub. No.: **WO2005/099494**

(57) **ABSTRACT**

PCT Pub. Date: **Oct. 27, 2005**

(65) **Prior Publication Data**

US 2007/0267031 A1 Nov. 22, 2007

(30) **Foreign Application Priority Data**

Apr. 14, 2004 (CN) 2004 2 0031182 U

(51) **Int. Cl.**

A24F 47/00 (2006.01)
A61M 15/06 (2006.01)

(52) **U.S. Cl.** 131/273; 128/200.14; 128/202.21;
 131/347; 131/359; 131/360

(58) **Field of Classification Search** 131/273,
 131/347, 359, 360; 128/200.14, 202.21
 See application file for complete search history.

(56) **References Cited**

U.S. PATENT DOCUMENTS

4,228,925 A 10/1980 Mendelovich

(Continued)

The invention relates to an electronic atomization cigarette which only contains nicotine without harmful tar. The electronic atomization cigarette includes a shell and a mouthpiece. The external wall of the shell has an air inlet. An electronic circuit board, a normal pressure cavity, a sensor, a vapor-liquid separator, an atomizer, a liquid-supplying bottle are sequentially provided within the shell, wherein the electronic circuit board comprises an electronic switching circuit and a high frequency generator. A stream passage of the sensor is provided on one side of the sensor, and a negative pressure cavity is provided in the sensor. The atomizer and the liquid-supplying bottle is in contact with each other. An atomization cavity is arranged in the atomizer. A retaining ring for locking the liquid-supplying bottle is provided between one side of the liquid-supplying bottle and the shell, and an aerosol passage is provided on the other side of the liquid-supplying bottle. The air inlet, normal pressure cavity, vapor-liquid separator, atomizer, aerosol passage, gas vent and mouthpiece are sequentially interconnected.

27 Claims, 5 Drawing Sheets

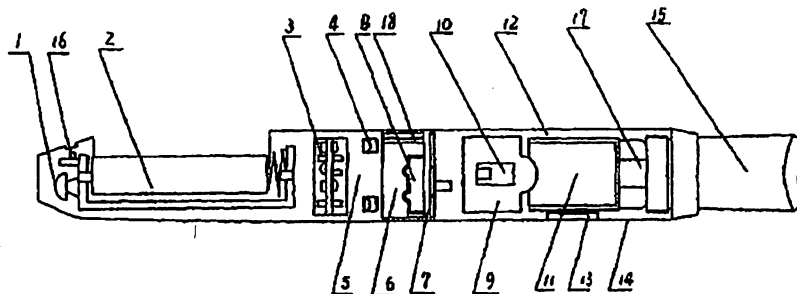

US 7,832,410 B2

Page 2

U.S. PATENT DOCUMENTS

4,641,053 A * 2/1987 Takeda 310/317
 4,848,374 A * 7/1989 Chard et al. 131/330
 4,945,929 A 8/1990 Egilmex
 4,945,931 A 8/1990 Gori
 5,042,470 A * 8/1991 Kanesaka 128/202.22
 5,080,114 A 1/1992 Rudolph et al.
 5,095,921 A 3/1992 Losee et al.
 5,190,060 A 3/1993 Gerding et al.
 5,322,075 A 6/1994 Deevi et al.
 5,666,978 A 9/1997 Counts et al.
 5,743,251 A 4/1998 Howell et al.
 5,894,841 A 4/1999 Voges
 6,040,560 A 3/2000 Fleischhauer et al.
 6,178,969 B1 1/2001 St. Charles
 6,196,218 B1 3/2001 Voges
 6,357,671 B1 * 3/2002 Cewers 239/102.2
 6,443,146 B1 9/2002 Voges
 6,532,965 B1 3/2003 Abhulimen et al.
 6,854,461 B2 2/2005 Nichols et al.
 2005/0016550 A1 * 1/2005 Katase 131/194

FOREIGN PATENT DOCUMENTS

CN 2047485 11/1989
 CN 2047485 U 11/1989
 CN 1135860 11/1996
 CN 2293957 Y 10/1998
 CN 1252961 5/2000
 CN 1196660 A 3/2010
 DE 100 51 792 5/2002
 EP 0 295 122 A2 12/1988
 EP 0342538 11/1989
 EP 0545186 6/1993
 EP 0 824 927 A 2/1998
 EP 0 845 220 A1 6/1998
 EP 0 893 071 A1 1/1999
 EP 0 970 627 A1 1/2000
 GB 1528391 A 10/1978
 JP 64-000498 U 1/1989
 JP 06-114105 A 4/1994
 JP 07-506999 A 8/1995
 JP 09-075058 A 3/1997
 UA 47514 C2 12/1997
 WO 97/48293 12/1997

WO WO 00/49901 8/2000
 WO WO 00/50111 8/2000
 WO 03/034847 1/2003
 WO 03/022364 A1 3/2003
 WO WO 03/055486 7/2003
 WO WO 03/101454 12/2003
 WO 2004/080216 9/2004
 WO WO 2004/095955 11/2004
 WO WO 2005/099494 10/2005

OTHER PUBLICATIONS

Supplementary Partial European Search Report for EP04718242 dated May 22, 2007 (4 pages).
 Supplementary European Search Report for EP04718242 dated Jul. 27, 2007 (7 pages).
 Supplementary Partial European Search Report for EP05729107 dated May 22, 2007 (4 pages).
 Supplementary European Search Report for EP05729107 dated Jul. 31, 2007 (6 pages).
 International Search Report for International Application No. PCT/CN2005/000337 dated Jul. 14, 2005 (3 pages).
 International Search Report for International Application No. PCT/CN2004/000182 dated Jun. 10, 2004 (2 pages).
 Malaysia Intellectual Property Office; Examiner's Report for Malaysian Application No. PI 20041407, dated Sep. 28, 2007.
 Australian Patent Office; Singapore Examination Report for Singapore Patent Application No. 0604498-6, mailed May 13, 2008.
 Australian Patent Office, Exam Report for AU2004234199 dated Aug. 14, 2009.
 Singapore Patent Office, Search and Examination Report for SG200604498-6 dated Apr. 16, 2008.
 European Patent Office, Supplementary European Search Report for EP05729107.2 dated Oct. 10, 2007.
 Japanese Patent Office, Office Action for JP2006-504199 dated Oct. 30, 2009 (English translation included).
 Korean Patent Office, Notice of Preliminary Rejection for KR10-2005-7009767 dated Jul. 27, 2009 (English translation included).
 Macau Patent Office, Official Communication for MOI/121 dated Apr. 17, 2009.
 Taiwan Intellectual Property Office, Official Letter for TW093111573 dated April 24, 2009 (English translation included).
 Ukrainian Patent Office, Examination Report for UK2005-11258 dated Feb. 4, 2009.

* cited by examiner

U.S. Patent

Nov. 16, 2010

Sheet 1 of 5

US 7,832,410 B2

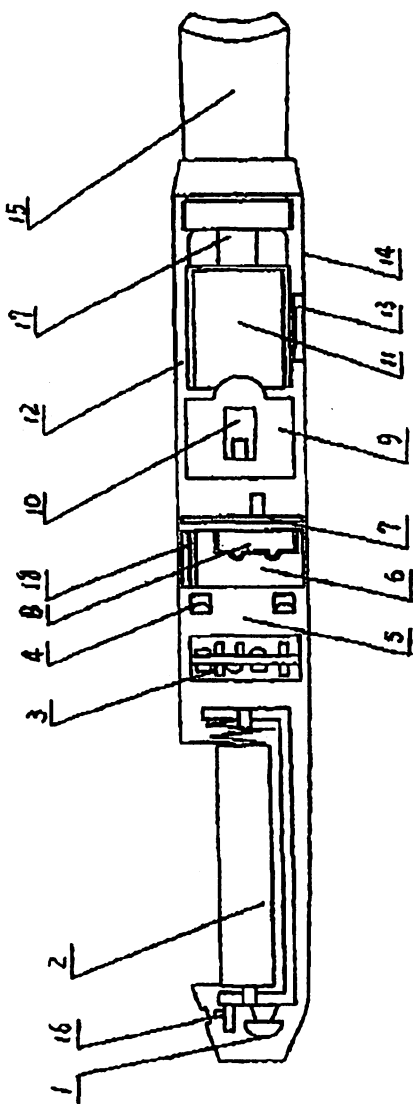

Fig. 1

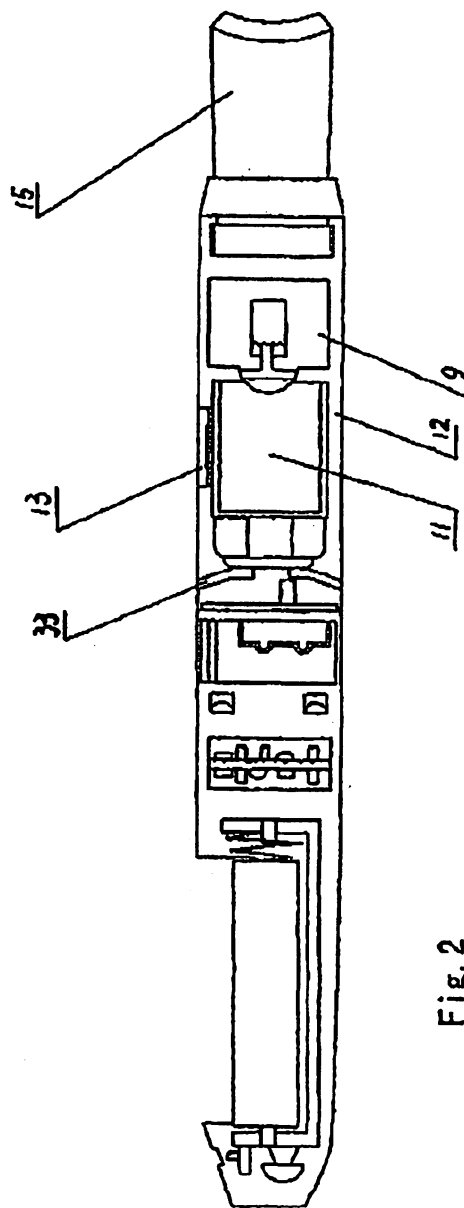

Fig. 2

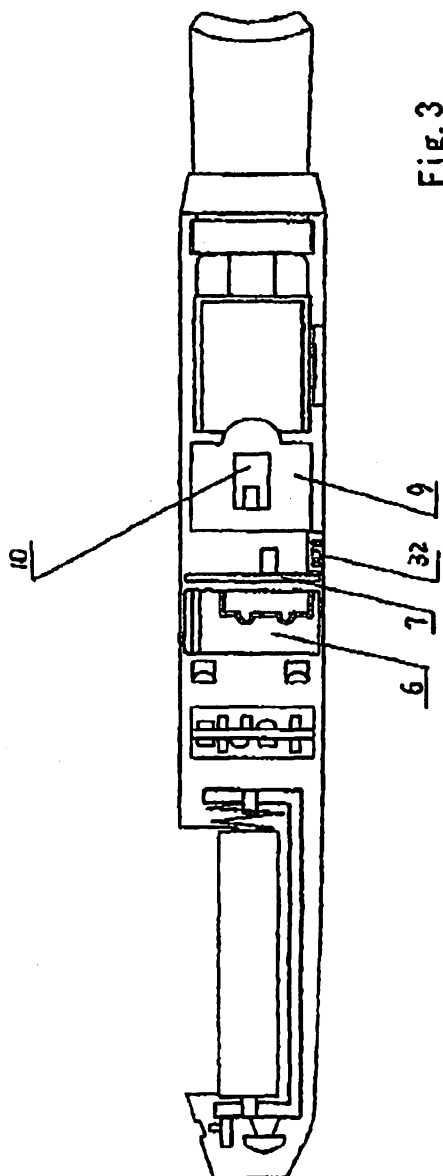

Fig. 3

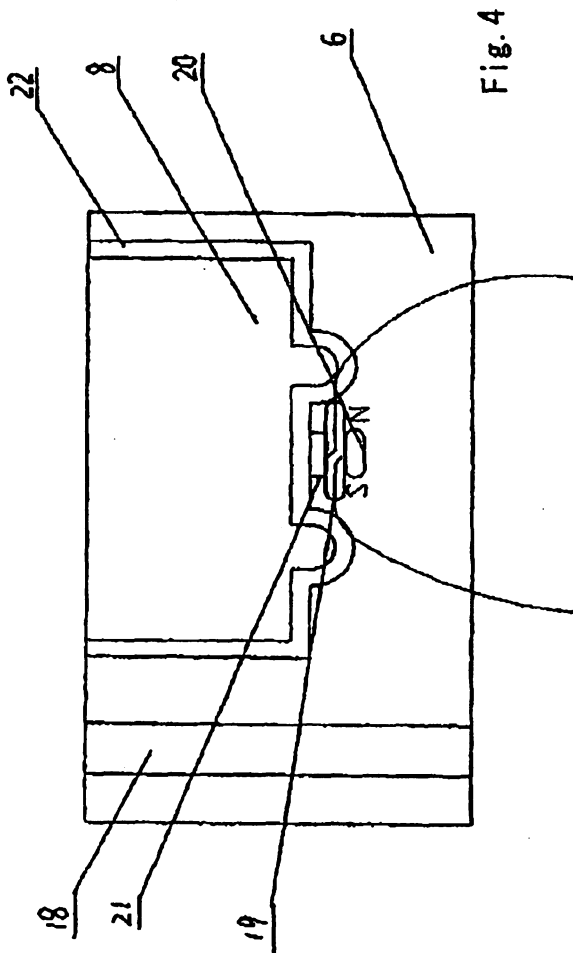

Fig. 4

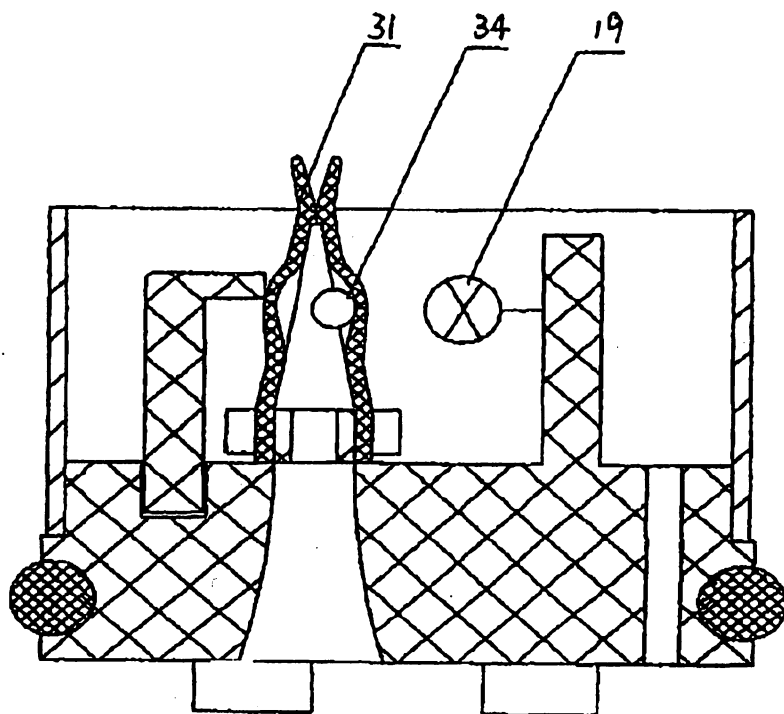

Fig. 5

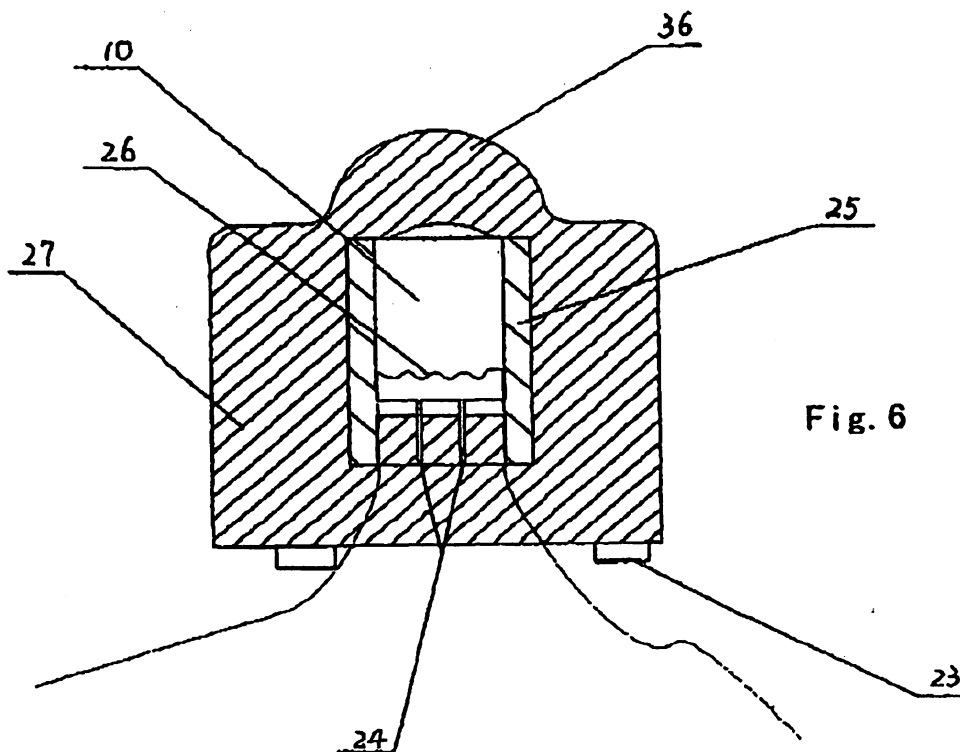

Fig. 6

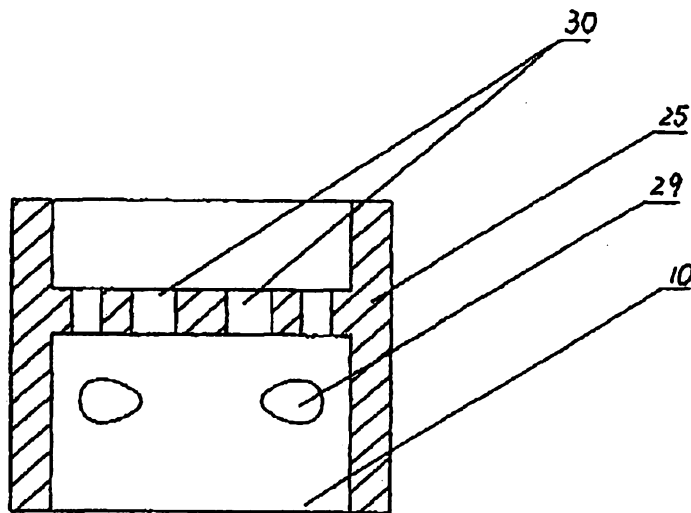

Fig. 7

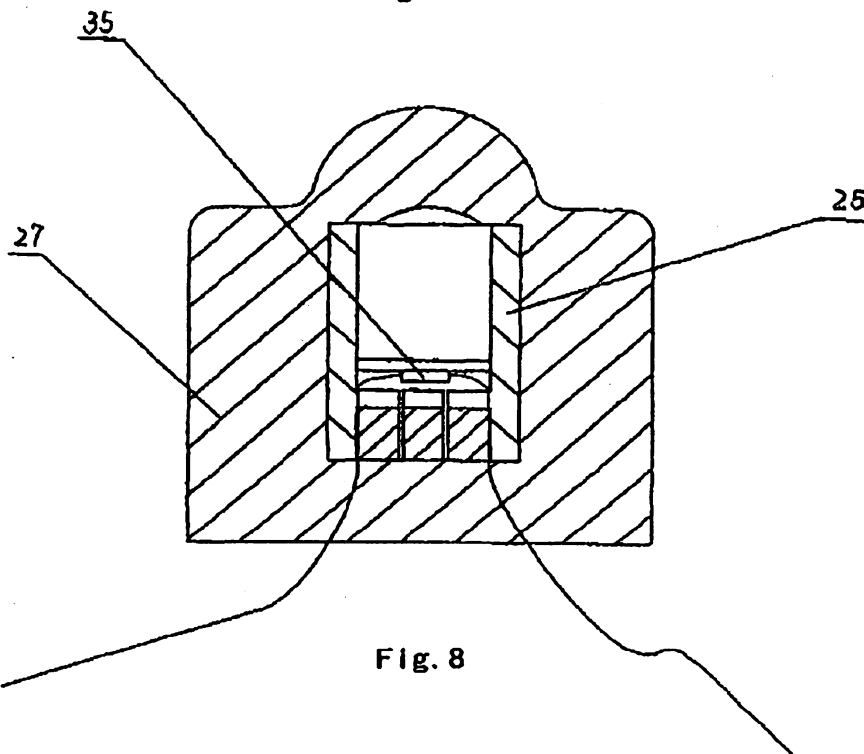

Fig. 8

U.S. Patent

Nov. 16, 2010

Sheet 5 of 5

US 7,832,410 B2

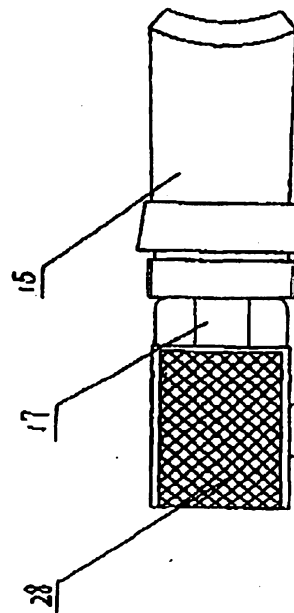
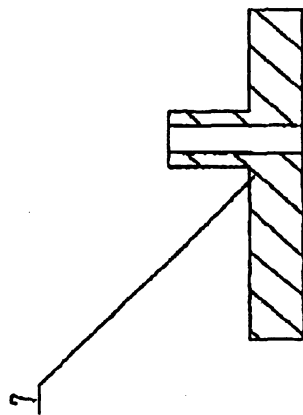
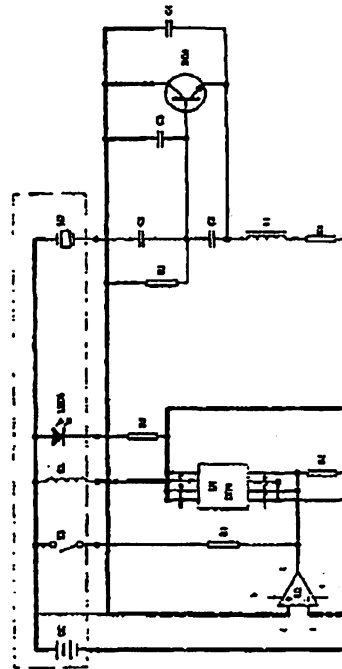
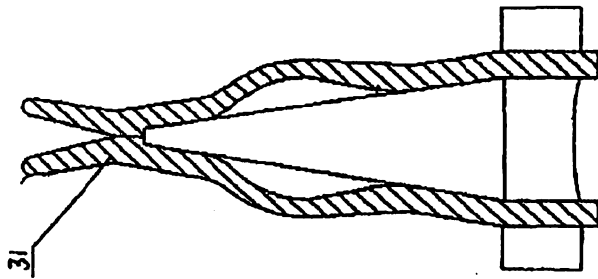

US 7,832,410 B2

1

ELECTRONIC ATOMIZATION CIGARETTE

TECHNICAL FIELD

The present invention relates to an electronic cigarette, in particular to an electronic atomization cigarette that contains only nicotine without tar.

BACKGROUND ART

Despite it is commonly known that "smoking is harmful to your health", the number of smokers worldwide is up to 1 billion, and the number is increasing every year. On Mar. 1, 2003, the World Health Organization (WHO) concluded a global Framework Convention on Tobacco Control. According to the statistical data from WHO, about 4.9 million people die of is diseases caused by smoking each year. Although smoking may cause serious respiratory diseases and cancer, it remains extremely difficult for smokers to quit smoking completely.

The active ingredient in a cigarette is nicotine. During smoking, nicotine, along with a lot of tar aerosol droplets produced in the cigarette burning, enters smoker's alveolus and is rapidly absorbed. After being absorbed into the blood of a smoker, nicotine then produces its effect on the receptors of the smoker's central nervous system, which makes him/her relax and enjoy an inebriety similar to that produced by an exhilarant.

Nicotine is a kind of alkaloid with low molecular weight and its half-life in blood is quite short. The major harmful subsantance in tobacco is tar, tar in tobacco is composed of thousands of ingredients, tens of which are carcinogenic substances. At present it has been proven that passive smoking can be more harmful to non-smokers.

Some cigarette substitutes flat contain only nicotine without tar have been proposed, many of them, such as "nicotine patch", "nicotine mouthwash", "spray agent packaged in high pressure gas tank with propellant", "nicotine chewing gum", "nicotine drink" etc., are made of pure nicotine. Although these cigarette substitutes are free from tar, their major disadvantage is that an effective peak concentration can not be reached in the blood of a smoker due to slow absorption of nicotine and thus it can not make a smoker get real fin, in addition, these cigarette substitutes can not satisfy habitual smoking actions of a smoker, for example, inhaling action or sucking action, and thus are not likely to be widely accepted as effective substitutes for quitting smoking or cigarette substitutes.

THE SUMMARY OF THE INVENTION

To overcome the above-referenced drawbacks, an objective of the present invention is to provide an electronic atomization cigarette that may function as a substitute for smoking cessation products or as a cigarette substitute.

The objective of the present invention is achieved by the following technical solution.

The present invention includes a shell; a mouthpiece; an air inlet provided in the external wall of the shell; an electronic circuit board, a normal pressure cavity, a sensor, a vapor-liquid separator, an atomizer, a liquid-supplying bottle arranged sequentially within the shell; a stream passage provided on one side of the sensor; a negative pressure cavity provided in the sensor; an atomization cavity arranged in the atomizer; a retaining ring for locking the liquid-supplying bottle provided between one side of the liquid-supplying bottle and the shell; and an aerosol passage provided on the

2

other side of the liquid-supplying bottle, wherein the electronic circuit board comprises an electronic switching circuit and a high frequency generator; the liquid-supplying bottle is in contact with the atomizer; and the air inlet, normal pressure cavity, vapor-liquid separator, atomizer, aerosol passage, gas vent and mouthpiece are sequentially interconnected. A LED and a cell are provided at the front end within the shell, collectively constituting an integrity like a cigarette holder, cigar or a pipe.

Furthermore, a display screen is additionally provided on the inner wall of the shell; a microswitch for manually cleaning is connected to the sensor in parallel connection within the shell; a ripple film is provided between the sensor and the negative pressure cavity inside the sensor; a first magnetic steel, a second magnetic steel and a Reed switch connected between them provided within the sensor, wherein the second magnetic steel is attached to the ripple film; a silicon gel check valve is provided within the sensor, a third magnetic steel is provided in the silicon gel check valve, and a Reed switch is provided outside the valve, on the side close to the magnetic steel; a through hole is arranged on the vapor-liquid separator, a silicon gel check valve covers the through hole on the vapor-liquid separator; a overflow hole is provided on the atomization cavity wall of the atomization cavity, a heating element is provided within the atomization cavity, a long stream ejection hole is provided on one side of the heating element, the porous body is arranged outside around the atomization cavity wall, the first piezoelectric element is provided on one side of the atomizer, and a bulge is provided on the other side; the second piezoelectric element is additionally provided in the atomizer; the porous body in the atomizer can be made of foam nickel, stainless steel fiber felt, high molecule polymer foam and foam ceramic; the heating element can be made of platinum wire, nickel chromium alloy or iron chromium aluminum alloy wire with rare earth element, or may be made into a sheet form with conductive ceramics or PTC ceramics; the atomization cavity wall can be made of aluminum oxide or ceramic; the vapor-liquid separator can be made of plastic or silicon rubber; the solution storage porous body is included in the liquid-supplying bottle, and can be filled with polypropylene fiber, terylene fiber or nylon fiber, or be filled with plastics that are shaped by foaming; alternatively, it may be modeled into a column with laminated layers by polyvinyl chloride, polypropylene, polycarbonate; the Reed switch, the first magnetic steel, the second magnetic steel, the ripple film can be replaced by a semiconductor strain gauge with sealed film, which is mounted in the place of the sensor ripple film.

The present invention also discloses an electronic atomization cigarette with another structure, wherein the atomizer is postposed within the shell, the liquid-supplying bottle is arranged between the vapor-liquid separator and the atomizer, and a spring piece for pressing the liquid-supplying bottle on the atomizer is arranged at one end of the liquid-supplying bottle.

The advantages of the present invention include smoking without tar, significantly reducing the cancerogenic risk. Furthermore users still feel as if they are smoking and experiencing the same excitement, and the cigarette is no need to be lit and is no fire risk.

US 7,832,410 B2

3

With slight modification of the solution storage container, the device and connecting structures of the present invention can be filled with conventional drug for pulmonary administration apparatus.

DESCRIPTION OF THE DRAWINGS

FIG. 1 is a schematic diagram of an overall structure according to the present invention;

FIG. 2 is a schematic diagram of another overall structure according to the present invention;

FIG. 3 is a schematic diagram of an overall structure with a display screen according to the present invention;

FIG. 4 is a structural diagram of a sensor according to the present invention;

FIG. 5 is a structural diagram of a sensor with a silicon gel check valve according to the present invention;

FIG. 6 is a structural diagram of an atomizer according to the present invention;

FIG. 7 is a structural diagram of the ceramic member in an atomizer according to the present invention;

FIG. 8 is a structural diagram of another atomizer according to the present invention;

FIG. 9 is a structural diagram of a vapor-liquid separator according to the present invention;

FIG. 10 is a structural diagram of another vapor-liquid separator according to the present invention;

FIG. 11 is a structural diagram of the connection of a liquid-supplying bottle and a mouthpiece according to the present invention;

FIG. 12 is a functional diagram of a circuit according to the present invention.

DETAILED DESCRIPTION OF THE INVENTION

The present invention is further described below with reference to the accompanying drawings.

Embodiment 1

As shown in FIG. 1, the present invention can form an integrity like a cigarette holder, a cigar or a pipe. An air inlet 4 is provided on the external wall of the shell 14. A LED 1, a cell 2, an electronic circuit board 3, a normal pressure cavity 5, a sensor 6, a vapor-liquid separator 7, an atomizer 9, a liquid-supplying bottle 11 and a mouthpiece 15 are sequentially provided within the shell 14. The electronic circuit board 3 comprises an electronic switching circuit and a high frequency generator. As shown in FIG. 4, a negative pressure cavity 8 is provided in the sensor 6 and is separated from the sensor 6 by a ripple film 22. A first magnetic steel 20, a second magnetic steel 21 and a Reed switch 19 arranged between them is also provided within the sensor 6, and the second magnetic steel 21 is attached to the ripple film 22. The atomizer 9 is in contact with the liquid-supplying bottle 11 via the bulge 36, and the atomization cavity 10 is provided in the atomizer 9. As shown in FIGS. 6 and 7, the overflow hole 29 is provided on the atomization cavity wall 25 of the atomization cavity 10. A heating element 26, which can be made of platinum wire, nickel chromium alloy or iron chromium aluminum alloy wire with rare earth element, is provided within the cavity, and can also be made into a sheet form with conductive ceramics or PTC ceramics. An ejection hole is provided on the side opposite to the heating element 26 and the ejection hole can be determined to select either the long stream ejection hole 24 or the short stream ejection hole 30, depending on the material used for the atomization cavity

4

wall 25. The long stream ejection hole 24 can employ slot structure of 0.1 mm-1.3 mm or circular hole structure of Φ 0.2 mm-1.3 mm with a single and multiple holes. The short stream ejection hole 30 has the diameter of about 0.3 mm-1.3 mm. The atomization cavity wall 25 is surrounded with the porous body 27, which can be made of foam nickel, stainless steel fiber felt, high molecule polymer foam and foam ceramic. A first piezoelectric element 23 is also provided on the atomizer 9. The atomization cavity wall 25 can be made of aluminum oxide or ceramic. As shown in FIG. 9, a through hole is provided on the vapor-liquid separator 7, and can be made of plastic or silicon rubber. As shown in FIG. 11, a retaining ring 13 for locking the liquid-supplying bottle 11 is provided between one side of the liquid-supplying bottle 11 and the shell 14, an aerosol passage 12 is provided on the other side of the liquid-supplying bottle. The solution storage porous body 28 is provided in the liquid-supplying bottle, and can be filled with polypropylene fiber, terylene fiber or nylon fiber, or be filled with plastic that are shaped by foaming, such as polyamine resin foam column or polypropylene foam column; alternatively, it may be made of a column formed by molding polyvinyl chloride, polypropylene, polycarbonate into a stack of laminated layers. The air inlet 4, normal pressure cavity 5, vapor-liquid separator 7, atomizer 9, aerosol passage 12, gas vent 17, mouthpiece 15 are sequentially interconnected.

As shown in the functional diagram of the circuit in FIG. 12, K1 refers to the Reed switch 19, RL refers to the heating element 26, LED1 refers to the Light Emitting Diode 1, U2 refers to the low voltage detecting element used for the over-discharging protection of the lithium cell, M1 refers to the first piezoelectric element 23, and C1, C2, R3, L1, C3, BG, M1 collectively constitute a Colpitts oscillator. The operating principle of the circuit is as follows: when K1 is closed, U1, i.e., the field effect power transistor, is turned on, RL starts, and the Colpitts oscillator starts oscillating, M1 will provide the high frequency mechanical oscillatory wave to the atomizer 9 to achieve the result of atomization.

When a smoker smokes, the mouthpiece 15 is under negative pressure, the air pressure difference or high speed stream between the normal pressure cavity 5 and the negative pressure cavity 8 will cause the sensor 6 to output an actuating signal, the electronic circuit board 3 connected therewith goes into operation. Now the ripple film 22 in the sensor 6 is deformed to take the second magnetic steel 21 away from the Reed switch 19, and the Reed switch 19 is then closed (i.e., K1 is closed) under the effect of the excessive magnetic line of force from the first magnetic steel 20, starting the field effect power. The high frequency oscillator may use the Colpitts oscillator with the frequency of automatic fine-adjusting element in the circuit resonates with the first piezoelectric element 23 in the form of a ring to supply power to liquid molecule, and the LED 1 can be lit under the supply of the rechargeable battery 2. The air enters the normal pressure cavity 5 through the air inlet 4, passes through the air passage 18 of the sensor and then the through hole in the vapor-liquid separator 7, and flows into the atomization cavity 10 in the atomizer 9. The high speed stream passing through the ejection hole drives the nicotine solution in the porous body 27 to eject into the atomization cavity 10 in the form of droplet, where the nicotine solution is subjected to the ultrasonic atomization by the first piezoelectric element 23 and is further atomized by the heating element 26. After the atomization the droplets with large diameter stick to the wall under the action of eddy flow and are reabsorbed by the porous body 27 via the overflow hole 29, whereas the droplets with small diameter float in stream and forms aerosols, which are sucked out via

US 7,832,410 B2

5

the aerosol passage 12, gas vent 17 and mouthpiece 15. The solution storage porous body 28 in the liquid-supplying bottle 11 will be in contact with the bulge 36 on the atomizer 9, thereby achieving the capillary infiltration liquid-supplying.

The mouthpiece 15 is threaded. When the nicotine solution in the liquid-supplying bottle 11 is used up, users can screw the mouthpiece 15 out to take the liquid-supplying bottle 11 out, refill the liquid-supplying bottle 11 with the nicotine solution, put the liquid-supplying bottle 11 into the shell 14 again, and then screw the mouthpiece 15.

The Reed switch 19, the first magnetic steel 20, the second magnetic steel 21, the ripple film 22 can be replaced by a semiconductor strain gauge with sealed film, which is mounted in the place of the sensor ripple film.

To simplify the design, the first piezoelectric element 23 on the atomizer 9 can be omitted, and the atomization of the nicotine solution will be made only by the heating element 26. The size of such an atomizer can be made smaller, and the structure of the connection of the whole electronic atomization cigarette is the same as the embodiment 1. In addition, as shown FIG. 8, the first piezoelectric element 23 and the heating element 26 in the atomizer 9 can be omitted, an additional second piezoelectric element 35 in the form of platen with a single layer or multiple laminated layers can be arranged in the atomization cavity, and the stream passing through the ejection hole vibrates the focus at the center of the second piezoelectric element 35 to achieve the effect of strong ultrasonic atomization.

As shown in FIG. 10, a silicon gel check valve 31 may cover the outside of the through hole on the vapor-liquid separator 7. During smoking, a stream reaches the through hole, as the air pressure in the through hole increases, the silicon gel check valve 31 is opened and the stream passes; otherwise, the silicon gel check valve 31 is closed.

As shown in FIG. 5, the sensor 6 may also be designed into a structure with the silicon gel check valve 31. During smoking, the stream comes into the silicon gel check valve 31, the air pressure increases and the air expands, the third magnetic steel 34 in the valve approaches the Reed switch 19 gradually until the Reed switch is closed and the circuit is turned on, and the air outlet of the silicon gel check valve 31 is opened with the increment of the air pressure difference. The Reed switch 19 can also be made of Hall device or magneto diode or magneto triode instead.

Embodiment 2

As shown in FIG. 2, to improve the liquid-supplying state, the atomizer 9 is postposed within the shell 14, and the liquid-supplying bottle 11 is arranged between the vapor-liquid separator 7 and the atomizer 9. A spring piece 33 for pressing the liquid-supplying bottle 11 on the atomizer 9 is provided on one end of the liquid-supplying bottle 11. Other components and their functions are the same as those in the embodiment 1.

On the inner wall of the shell 14 of the electronic atomization cigarette described in the embodiment 1 and 2, a digital display screen 32 for showing the smoking times per day and the cell capacity can be also provided. The sensor 6 uses a linear signal output, which is proportional to the suction force (i.e., the stronger one sucks, the longer the time of operation is), the atomizer 9 operates in the linear mode, thereby simulating a humanized cigarette that looks like a normal cigarette.

Within the shell 14, the microswitch 16 is connected to the sensor 6 in parallel and used for manually cleaning. When users do not smoke, they press the microswitch 16 to start the

6

sensor 6 connected therewith in parallel, or clean the residue or other impurity substance within the shell 14.

The nicotine solution for atomization contains 0.4-3.5% nicotine, 0.05-2% cigarette essence, 0.1-3.1% organic acid, 0.1-0.5% anti-oxidation agent, and the rest is 1,2-propylene glycol.

What is claimed is:

1. An electronic atomization cigarette, comprising:
 - a shell;
 - a mouthpiece;
 - an air inlet provided on the external wall of the shell;
 - a cell, an electronic circuit board, a normal pressure cavity, a sensor, a vapor-liquid separator, an atomizer, a liquid-supplying bottle arranged sequentially within the shell;
 - a stream passage provided on one side of the sensor;
 - a gas vent;
 - a negative pressure cavity provided in the sensor;
 - an atomization cavity arranged in the atomizer;
 - an aerosol passage provided on one side of the liquid-supplying bottle;
 - wherein the liquid-supplying bottle is in contact with the atomizer;
 - a ripple film provided between the sensor and the negative pressure cavity within the sensor;
 - a first magnetic steel, a second magnetic steel and a magneto device connected between said first and second magnetic steel provided within the sensor, wherein the second magnetic steel is attached to the ripple film; and
 - the air inlet, normal pressure cavity, vapor-liquid separator, atomizer, aerosol passage, the gas vent and mouthpiece are sequentially interconnected.
2. The electronic atomization cigarette according to claim 1, wherein the magneto device is a Reed switch.
3. The electronic atomization cigarette according to claim 1, wherein the magneto device is a Hall device.
4. The electronic atomization cigarette according to claim 1, wherein the magneto device is a magneto diode.
5. The electronic atomization cigarette according to claim 1, wherein the magneto device is a magnetic triode.
6. The electronic atomization cigarette according to claim 1, further comprising:
 - a silicon gel check valve provided within the sensor;
 - a third magnetic steel provided in the silicon gel check valve; and
 - a Reed switch provided outside the silicon gel check valve, on a side close to the magnetic steel.
7. The electronic atomization cigarette according to claim 1, further comprising:
 - a heating element provided within the atomization cavity;
 - a stream ejection hole provided on one side of the heating element; and
 - a porous body arranged outside around a wall of the atomization cavity.
8. The electronic atomization cigarette according to claim 1, further comprising:
 - a first piezoelectric element provided on one side of the atomizer; and
 - a bulge provided on the other side of the atomizer.
9. The electronic atomization cigarette according to claim 7, wherein the stream ejection hole is a long stream ejection hole with 0.1 mm-1.3 mm of slot structure.
10. The electronic atomization cigarette according to claim 7, wherein the stream ejection hole is a long stream ejection hole with ϕ 0.2 mm-1.3 mm of circular hole structure having a single and multiple holes.

US 7,832,410 B2

7

11. The electronic atomization cigarette according to claim 7, wherein the stream ejection hole is a short stream ejection hole with a diameter of 0.3 mm-1.3 mm.

12. The electronic atomization cigarette according to claim 1, further comprising:

a piezoelectric element provided in the atomizer, wherein a stream passing through an ejection hole is atomized at a central vibration focus of the piezoelectric element to achieve an effect of strong ultrasonic atomization.

13. The electronic atomization cigarette according to claim 12, wherein the piezoelectric element comprises a platen with a single layer.

14. The electronic atomization cigarette according to claim 12, wherein the piezoelectric element comprises a platen with laminated layers.

15. The electronic atomization cigarette according to claim 1, wherein the atomizer is surrounded by a porous body which can be made of foam nickel, stainless steel fiber felt, high molecule polymer foam and foam ceramic.

16. The electronic atomization cigarette according to claim 7, wherein the heating element is made of platinum wire, nickel chromium alloy or iron chromium aluminum alloy wire with rare earth element.

17. The electronic atomization cigarette according to claim 7, wherein the heating element is made into a sheet comprising ceramics.

18. The electronic atomization cigarette according to claim 1, wherein the atomization cavity comprises a wall made of aluminum oxide.

19. The electronic atomization cigarette according to claim 1, wherein the atomization cavity comprises a wall made of ceramics.

20. An electronic atomization cigarette, comprising:
a shell;
a mouthpiece;
an air inlet provided on the external wall of the shell;
a cell, an electronic circuit board, a normal pressure cavity, a sensor, a vapor-liquid separator, an atomizer, a liquid-supplying bottle arranged sequentially within the shell;
a stream passage provided on one side of the sensor;
a gas vent;
a negative pressure cavity provided in the sensor;
an atomization cavity arranged in the atomizer;

8

an aerosol passage provided on one side of the liquid-supplying bottle, wherein the liquid-supplying bottle is in contact with the atomizer; and

a through hole arranged on the vapor-liquid separator wherein the air inlet, normal pressure cavity, vapor-liquid separator, atomizer, aerosol passage, the gas vent and mouthpiece are sequentially interconnected.

21. The electronic atomization cigarette according to claim 20, further comprising:

a silicon gel check valve covering the outside of the through hole on the vapor-liquid separator.

22. The electronic atomization cigarette according to claim 20, wherein the vapor-liquid separator is made of plastics.

23. The electronic atomization cigarette according to claim 20, wherein the vapor-liquid separator is made of silicon rubber.

24. An electronic atomization cigarette, comprising:
a shell;
a mouthpiece;

an air inlet provided on the external wall of the shell;
a cell, an electronic circuit board, a normal pressure cavity, a sensor, a vapor-liquid separator, an atomizer, a liquid-supplying bottle arranged sequentially within the shell;
a stream passage provided on one side of the sensor;
a negative pressure cavity provided in the sensor;
an atomization cavity arranged in the atomizer; and
an aerosol passage provided on one side of the liquid-supplying bottle, wherein the liquid-supplying bottle is in contact with the atomizer;

wherein the air inlet, normal pressure cavity, vapor-liquid separator, atomizer, aerosol passage, gas vent and mouthpiece are sequentially interconnected and wherein a solution storage porous body is provided in the liquid-supplying bottle.

25. The electronic atomization cigarette according to claim 24, wherein the solution storage porous body is filled with polypropylene fiber, terylene fiber or nylon fiber.

26. The electronic atomization cigarette according to claim 24, wherein the solution storage porous body is filled with plastics that are shaped by foaming.

27. The electronic atomization cigarette according to claim 24, wherein the solution storage porous body is molded into a column with laminated layers by polyvinyl chloride, polypropylene, polycarbonate.

* * * * *