

COPY

FILED

2009 JUL -9 AM 6:04

CLERK, U.S. DISTRICT COURT  
CENTRAL DIST. OF CALIF.  
EASTERN DIVISION

BY:

1 BARCELO & HARRISON, LLP  
2 Reynaldo C. Barceló (199741)  
3 rey@bhiplaw.com  
4 2901 West Coast Hwy, Suite 200  
5 Newport Beach, California 92663  
6 Telephone: (949) 340-9736  
7 Facsimile: (949) 258-5752

8  
9 Attorneys for Plaintiff,  
10 TMI PRODUCTS, INC.

11 UNITED STATES DISTRICT COURT  
12 CENTRAL DISTRICT OF CALIFORNIA

13 ED CV 09 - 01300 SGL

14 TMI PRODUCTS, INC.,

Case No.

15 Plaintiff

COMPLAINT FOR PATENT  
INFRINGEMENT (OPX)

16 v.

DEMAND FOR JURY TRIAL

17 ROSEN ENTERTAINMENT  
18 SYSTEMS, L.P.

19 Defendant

20  
21  
22  
23  
24  
25  
26  
27  
28

1 For its complaint against Rosen Entertainment Systems, L.P. (“Rosen,” or  
2 “Defendant”), Plaintiff TMI Products, Inc. (“TMI”) alleges as follows:

3 **THE PARTIES**

4 1. TMI is a corporation duly organized and existing under the laws of the  
5 California, with its principal place of business at 1493 E. Bentley Drive, Corona,  
6 California 92879. TMI holds an exclusive license to U.S. Patent Nos. 7,040,697  
7 (“the ’697 patent”) and 7,407,227 (“the ’227 patent”) (collectively, “the Patents in  
8 Suit”). TMI’s exclusive license includes the exclusive world-wide rights to  
9 sublicense the ’697 and ’227 patents, and to enforce the ’697 and ’227 patents  
10 against alleged infringers.

11 2. Upon information and belief, Rosen is a partnership organized and  
12 existing under the laws of the State of California, with its principal place of business  
13 at 1120 California Avenue, Corona, California 92881.

14 **NATURE OF THE ACTION**

15 3. In this civil action, TMI seeks damages and injunctive relief against  
16 Defendant for acts of patent infringement in violation of the Patent Act of the United  
17 States, 35 U.S.C. §§ 1 et seq.

18 **JURISDICTION AND VENUE**

19 4. This Court has subject matter jurisdiction pursuant to the provisions of  
20 28 U.S.C. §§ 1331 and 1338(a), because this is an action for patent infringement  
21 arising under the laws of the United States, including 35 U.S.C. §§ 1 et seq.

22 5. Venue is proper under 28 U.S.C. §§ 1391(c) and 1400(b), in that the  
23 acts and transactions complained of herein were conceived, carried out, made  
24 effective, or had effect within the State of California and within this Judicial  
25 District, among other places.

26 6. On information and belief, Rosen resides in this Judicial District by  
27 virtue of its business activities in this Judicial District. For example, and without  
28 limitation, on information and belief, Rosen is licensed to do business in California

1 by the California Secretary of State, and Rosen maintains a registered agent for  
2 service of process in this Judicial District.

3 7. On information and belief, Rosen markets and sells, throughout the  
4 United States and including in this Judicial District, headrest mountable video  
5 systems.

6 8. On information and belief, based at least on the facts stated above, this  
7 Court has personal jurisdiction over Defendant.

8 **BACKGROUND**

9 9. On May 9, 2006, the United States Patent & Trademark Office duly  
10 and legally issued United States Letters Patent No. 7,040,697 (“the ’697 patent”),  
11 entitled “HEADREST HAVING AN INTEGRATED VIDEO SCREEN.” A true  
12 and correct copy of the ’697 Patent is attached as Exhibit A and incorporated herein  
13 by reference.

14 10. On August 5, 2008, the United States Patent & Trademark Office duly  
15 and legally issued United States Letters Patent No. 7,407,227 (“the ’227 patent”),  
16 entitled “HEADREST HAVING AN INTEGRATED VIDEO SCREEN.” A true  
17 and correct copy of the ’227 Patent is attached as Exhibit B and incorporated herein  
18 by reference.

19 **FIRST CLAIM FOR RELIEF**

20 **(Infringement of U.S. Patent No. 7,040,697)**

21 11. TMI incorporates herein by reference the allegations set forth in  
22 paragraphs 1-12 of this Complaint as though fully set forth herein.

23 12. On information and belief, Calli Ventosa, Inc. and Tierra Vista Corp.  
24 are the joint legal owners by assignment of the ’697 patent from Timely  
25 Innovations, LP, which is the original assignee listed on the front page of the ’697  
26 patent. TMI is the exclusive licensee of the ’697 patent, having acquired from Calli  
27 Ventosa, Inc. and Tierra Vista Corp. substantially all rights in the ’697 patent,  
28

1 including the exclusive world-wide right to sublicense the '697 patent and to enforce  
2 the '697 patent against any and all infringers.

3 13. Defendant has directly infringed and continues to directly infringe the  
4 '697 Patent by making, using, selling, or offering for sale in or importing into the  
5 United States mobile video headrest systems that embody or otherwise practice one  
6 or more of the claims of the '697 Patent, such as, without limitation, products and  
7 systems marketed as the "AV7000 Dual DVD Headrest Replacement System" and  
8 the "AV7500 Dual DVD Headrest Replacement System."

9 14. On information and belief, Defendant has indirectly infringed and  
10 continues to indirectly infringe the '697 Patent by actively inducing direct  
11 infringement by other persons who operate and/or use mobile video headrest  
12 systems such as, without limitation, products and systems marketed as the "AV7000  
13 Dual DVD Headrest Replacement System" and the "AV7500 Dual DVD Headrest  
14 Replacement System," or otherwise practice one or more of the claims of the '697  
15 Patent, when Defendant had knowledge of the '697 Patent and knew or should have  
16 known that its actions would induce direct infringement by others and intended that  
17 its actions would induce direct infringement by others.

18 15. On information and belief, Defendant has indirectly infringed and  
19 continue to indirectly infringe the '697 Patent by contributory infringement by  
20 providing non-staple articles of commerce to others for use in an infringing system  
21 or method with respect to mobile video headrest systems such as, without limitation,  
22 products and systems marketed as the "AV7000 Dual DVD Headrest Replacement  
23 System" and the "AV7500 Dual DVD Headrest Replacement System." with  
24 knowledge of the '697 Patent and knowledge that these non-staple articles of  
25 commerce are used as a material part of the claimed inventions of the '697 Patent.

26 16. On information and belief, Defendant will continue to infringe the '697  
27 Patent as alleged in this Complaint unless enjoined by this Court.

28

1 17. On information and belief, Defendant's infringement of the '697 patent  
2 is, has been, and continues to be willful and deliberate.

3 18. As a direct and proximate result of Defendant's infringement of the  
4 '697 patent, TMI has been and continues to be damaged in an amount yet to be  
5 determined.

6 19. Unless Defendant and its respective officers, agents, servants, and  
7 employees, and all persons acting in concert with Defendant, are enjoined from  
8 infringing the '697 patent, TMI will be greatly and irreparably harmed.

9 20. By reason of the above acts, TMI is entitled to injunctive relief  
10 enjoining and restraining Defendant, and its respective officers, agents, servants, and  
11 employees, and all persons acting in concert with Defendant, from further  
12 infringement of the '697 patent.

13 **SECOND CLAIM FOR RELIEF**

14 **(Infringement of U.S. Patent No. 7,407,227)**

15 21. TMI incorporates herein by reference the allegations set forth in  
16 paragraphs 1-12 of this Complaint as though fully set forth herein.

17 22. On information and belief, Calli Ventosa, Inc. and Tierra Vista Corp.  
18 are the joint legal owners by assignment of the '227 patent from Timely  
19 Innovations, LP, which is the original assignee listed on the front page of the '227  
20 patent. TMI is the exclusive licensee of the '227 patent, having acquired from Calli  
21 Ventosa, Inc. and Tierra Vista Corp. substantially all rights in the '227 patent,  
22 including the exclusive world-wide right to sublicense the '227 patent and to enforce  
23 the '227 patent against any and all infringers.

24 23. Defendant has directly infringed and continue to directly infringe the  
25 '227 Patent by making, using, selling, or offering for sale in or importing into the  
26 United States mobile video headrest systems that embody or otherwise practice one  
27 or more of the claims of the '227 Patent, such as, without limitation, products and  
28

1 systems marketed as the “AV7000 Dual DVD Headrest Replacement System” and  
2 the “AV7500 Dual DVD Headrest Replacement System.”

3       24. On information and belief, Defendant has indirectly infringed and  
4 continues to indirectly infringe the ’227 Patent by actively inducing direct  
5 infringement by other persons who operate and/or use mobile video headrest  
6 systems such as, without limitation, products and systems marketed as the “AV7000  
7 Dual DVD Headrest Replacement System” and the “AV7500 Dual DVD Headrest  
8 Replacement System,” or otherwise practice one or more of the claims of the ’227  
9 Patent, when Defendant had knowledge of the ’227 Patent and knew or should have  
10 known that its actions would induce direct infringement by others and intended that  
11 its actions would induce direct infringement by others.

12       25. On information and belief, Defendant has indirectly infringed and  
13 continues to indirectly infringe the ’227 Patent by contributory infringement by  
14 providing non-staple articles of commerce to others for use in an infringing system  
15 or method with respect to mobile video headrest systems such as, without limitation,  
16 products and systems marketed as the “AV7000 Dual DVD Headrest Replacement  
17 System” and the “AV7500 Dual DVD Headrest Replacement System,” with  
18 knowledge of the ’227 Patent and knowledge that these non-staple articles of  
19 commerce are used as a material part of the claimed inventions of the ’227 Patent.

20       26. On information and belief, Defendant will continue to infringe the ’227  
21 Patent as alleged in this Complaint unless enjoined by this Court.

22       27. On information and belief, Defendant’s infringement of the ’227 patent  
23 is, has been, and continues to be willful and deliberate.

24       28. As a direct and proximate result of Defendant’s infringement of the  
25 ’227 patent, TMI has been and continues to be damaged in an amount yet to be  
26 determined.

27  
28

1 29. Unless Defendant and its respective officers, agents, servants, and  
2 employees, and all persons acting in concert with Defendant, are enjoined from  
3 infringing the '227 patent, TMI will be greatly and irreparably harmed.

4 30. By reason of the above acts, TMI is entitled to injunctive relief  
5 enjoining and restraining Defendant, and its respective officers, agents, servants, and  
6 employees, and all persons acting in concert with Defendant, from further  
7 infringement of the '227 patent.

8 **PRAYER FOR RELIEF**

9 WHEREFORE, TMI prays for judgment against Defendant as follows:

10 1. For a judicial determination and declaration that Defendant directly  
11 infringes United States Letters Patent Nos. 7,040,697 and 7,407,227 by making,  
12 using, offering to sell and/or selling mobile video headrest systems such as, without  
13 limitation, products and systems marketed as the “AV7000 Dual DVD Headrest  
14 Replacement System” and the “AV7500 Dual DVD Headrest Replacement  
15 System”;

16 2. For a judicial determination and declaration that Defendant induces  
17 direct infringement of United States Letters Patent Nos. 7,040,697 and 7,407,227;

18 3. For a judicial determination and declaration that Defendant commits  
19 contributory infringement of United States Letters Patent Nos. 7,040,697 and  
20 7,407,227;

21 4. For a judicial determination and decree that Defendant’s infringement  
22 of United States Letters Patent Nos. 7,040,697 and 7,407,227 is willful;

23 5. For damages resulting from Defendant’s past and present infringement  
24 of United States Letters Patent Nos. 7,040,697 and 7,407,227, and the trebling of  
25 such damages because of the willful and deliberate nature of its infringement;

26 6. For injunctive relief against further infringement of United States  
27 Letters Patent Nos. 7,040,697 and 7,407,227 by Defendant, its respective officers,  
28

1 directors, shareholders, agents, servants, employees, and all other entities and  
2 individuals acting in concert with the enjoined entities or on their behalf;

3 7. For a declaration that this is an exceptional case under 35 U.S.C. § 285  
4 and for an award of attorneys' fees and costs in this action;

5 8. For an assessment of prejudgment interest; and

6 9. For such other and further relief as the Court may deem just and proper  
7 under the circumstances.

8 Dated: July 9, 2009 By: Reynaldo C. Barceló

Reynaldo C. Barceló (199741)  
BARCELO & HARRISON, LLP  
2901 West Coast Hwy, Suite 200  
Newport Beach, CA 92663  
(949) 340-9736

*Attorneys for Plaintiff, TMI Products, Inc.*

**DEMAND FOR JURY TRIAL**

16 TMI hereby demands a jury trial pursuant to Rule 38 of the Federal Rules of  
17 Civil Procedure as to all issues in this lawsuit.

19 Dated: July 9, 2009 By: Reynaldo C. Barceló

Reynaldo C. Barceló (199741)  
BARCELO & HARRISON, LLP  
2901 West Coast Hwy, Suite 200  
Newport Beach, CA 92663  
(949) 340-9736

*Attorneys for Plaintiff, TMI Products, Inc.*



# **EXHIBIT A**

(12) **United States Patent**  
**Tuccinardi et al.**

(10) **Patent No.:** **US 7,040,697 B1**  
 (45) **Date of Patent:** **May 9, 2006**

(54) **HEADREST HAVING AN INTEGRATED VIDEO SCREEN**

(75) Inventors: **Eugene M. Tuccinardi**, Temecula, CA (US); **Ernesto R. Haack**, Perris, CA (US); **Robert Murphy**, Lake Elsinore, CA (US); **Frank Barrese**, Temecula, CA (US); **Roel C. Espina**, Loma Linda, CA (US); **Jon A. Molo**, Ontario, CA (US); **Theo Zoetemelk**, Riverside, CA (US)

5,267,775 A 12/1993 Nguyen  
 5,292,174 A 3/1994 Ohnuma  
 5,293,244 A \* 3/1994 Kawaguchi ..... 348/789  
 5,311,302 A 5/1994 Berry et al.  
 5,333,416 A 8/1994 Harris et al.  
 5,359,349 A 10/1994 Jambor et al.  
 5,507,556 A \* 4/1996 Dixon ..... 297/217.3  
 5,529,265 A 6/1996 Sakurai  
 5,555,466 A 9/1996 Scribner et al.  
 5,640,297 A 6/1997 Labaze  
 5,713,633 A 2/1998 Lu

(73) Assignee: **Timely Innovations, LP**, Temecula, CA (US)

(\* ) Notice: Subject to any disclaimer, the term of this patent is extended or adjusted under 35 U.S.C. 154(b) by 0 days.

(21) Appl. No.: **10/395,870**

(22) Filed: **Mar. 20, 2003**

(51) **Int. Cl.**  
*A47C 31/00* (2006.01)  
*A47C 7/62* (2006.01)

(52) **U.S. Cl.** ..... **297/217.3; 297/188.04**  
 (58) **Field of Classification Search** ..... 297/217.3, 297/188.04, 188.07, 185; 411/510; 312/242, 312/245

See application file for complete search history.

(56) **References Cited**

U.S. PATENT DOCUMENTS

3,004,815 A \* 10/1961 O’Kain et al. .... 312/242  
 4,584,603 A 4/1986 Harrison  
 4,635,110 A 1/1987 Weinblatt  
 4,647,980 A 3/1987 Steventon et al.  
 4,756,528 A 7/1988 Umashankar  
 4,776,739 A \* 10/1988 Hamman ..... 411/510  
 4,788,588 A 11/1988 Tomita  
 4,866,515 A 9/1989 Tagawa et al.  
 RE33,423 E \* 11/1990 Lobanoff ..... 297/188.06  
 4,983,951 A 1/1991 Igarashi et al.

(Continued)

FOREIGN PATENT DOCUMENTS

DE 3637772 A1 \* 5/1988

(Continued)

*Primary Examiner*—Peter M. Cuomo

*Assistant Examiner*—Sarah B. McPartlin

(74) *Attorney, Agent, or Firm*—Knobbe, Martens, Olson & Bear, LLP

(57) **ABSTRACT**

A seat back video display assembly adapted to be positioned in the back of a vehicle seat having an outer skin cover. In one aspect, the assembly may comprise a receptacle member having sidewalls and a back wall so as to define an opening wherein the receptacle member is adapted to be positioned in the back of the vehicle seat. In addition, the assembly may further comprise a carrier member having sidewalls and a back wall so as to define an opening, wherein the carrier member includes at least one fastener that extends from the back wall of the carrier member and engages with the back wall of the receptacle member to secure the carrier member into the receptacle member. Moreover, the assembly may still further comprise a video display unit that is sized so as to be positioned secured within the opening in the carrier member, wherein the video display unit provides video signals.

**24 Claims, 10 Drawing Sheets**

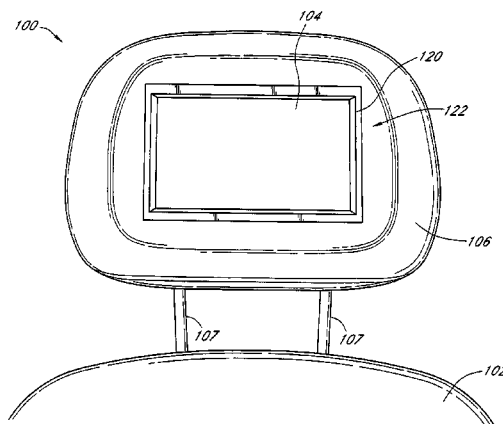

**US 7,040,697 B1**

Page 2

U.S. PATENT DOCUMENTS

D398,921 S 9/1998 Rosen  
 5,842,715 A 12/1998 Jones  
 6,024,027 A \* 2/2000 Esmaili ..... 109/50  
 D434,400 S 11/2000 Rosen  
 6,199,948 B1 3/2001 Bush et al.  
 6,216,927 B1 4/2001 Meritt  
 6,250,967 B1 6/2001 Chu  
 6,292,236 B1 9/2001 Rosen  
 6,339,455 B1 1/2002 Allan et al.  
 6,394,551 B1 5/2002 Beukema  
 6,406,334 B1 6/2002 Chu  
 6,409,242 B1 6/2002 Chang  
 6,480,243 B1 \* 11/2002 Yamamoto ..... 348/836

6,669,285 B1 \* 12/2003 Park et al. .... 297/217.3  
 6,739,654 B1 \* 5/2004 Shen et al. .... 297/188.04  
 6,750,599 B1 \* 6/2004 Tajima ..... 313/292  
 6,755,491 B1 \* 6/2004 McElheney ..... 312/242  
 2001/0008266 A1 7/2001 Lambert  
 2003/0025367 A1 2/2003 Boudinot  
 2004/0007906 A1 \* 1/2004 Park et al. .... 297/217.3  
 2004/0160096 A1 \* 8/2004 Boudinot ..... 297/217.3

FOREIGN PATENT DOCUMENTS

FR 2764563 A1 12/1998  
 JP 01094048 A 4/1989

\* cited by examiner

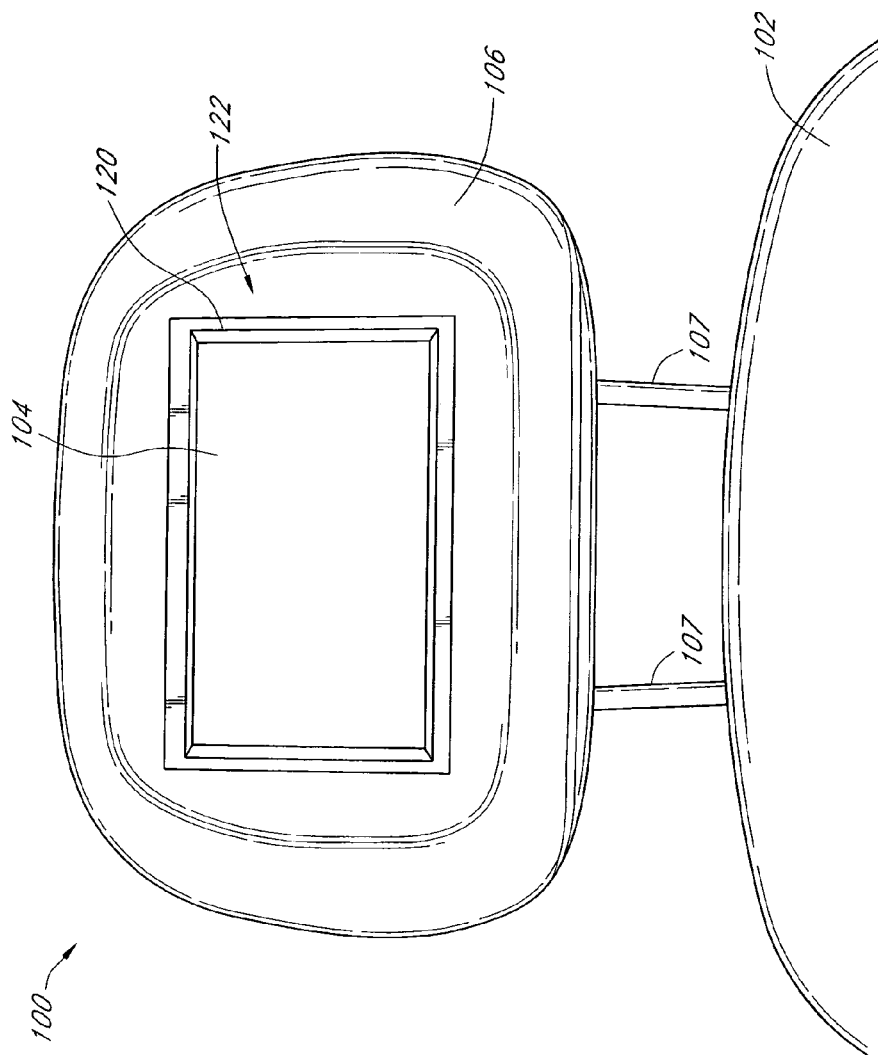

FIG. 1A

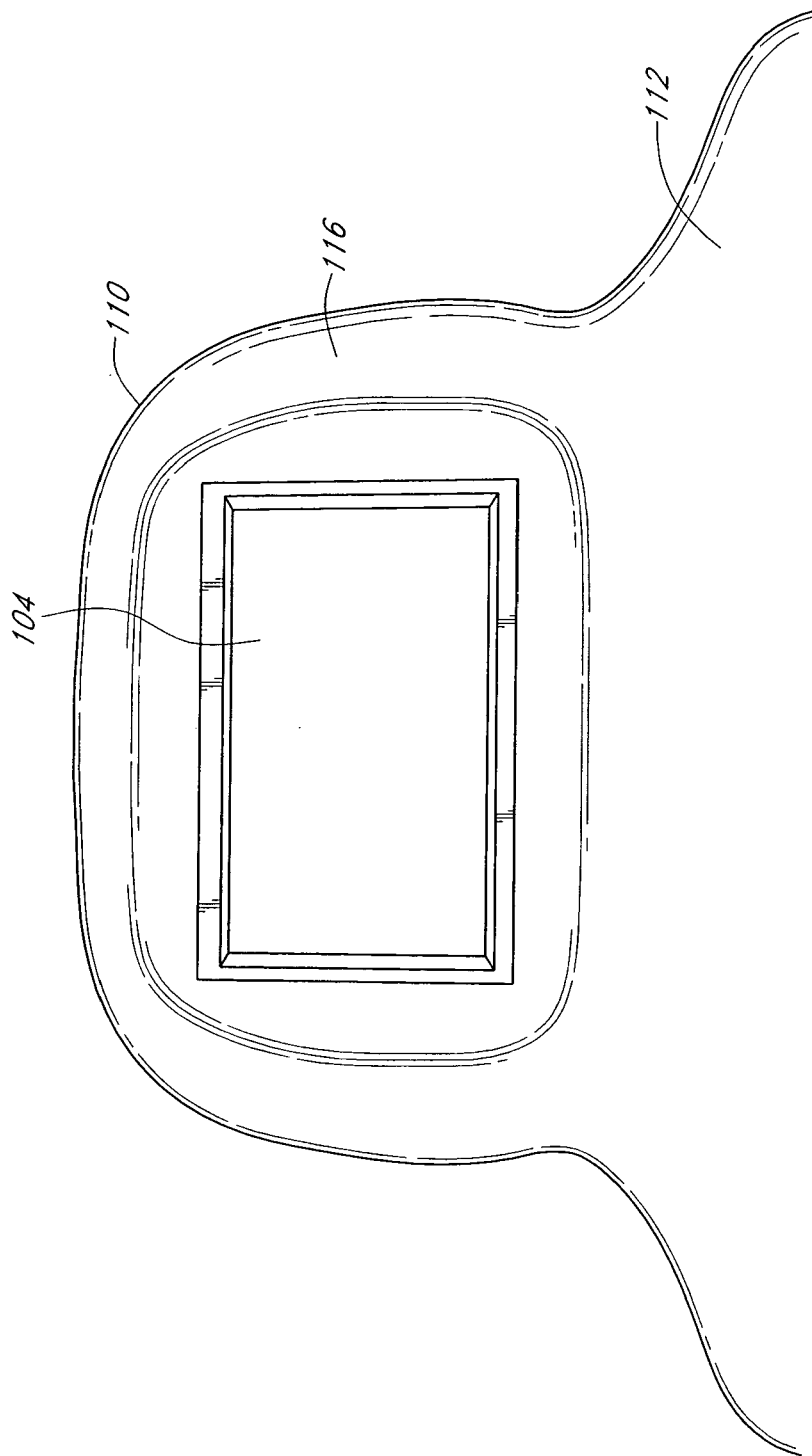

FIG. 1B

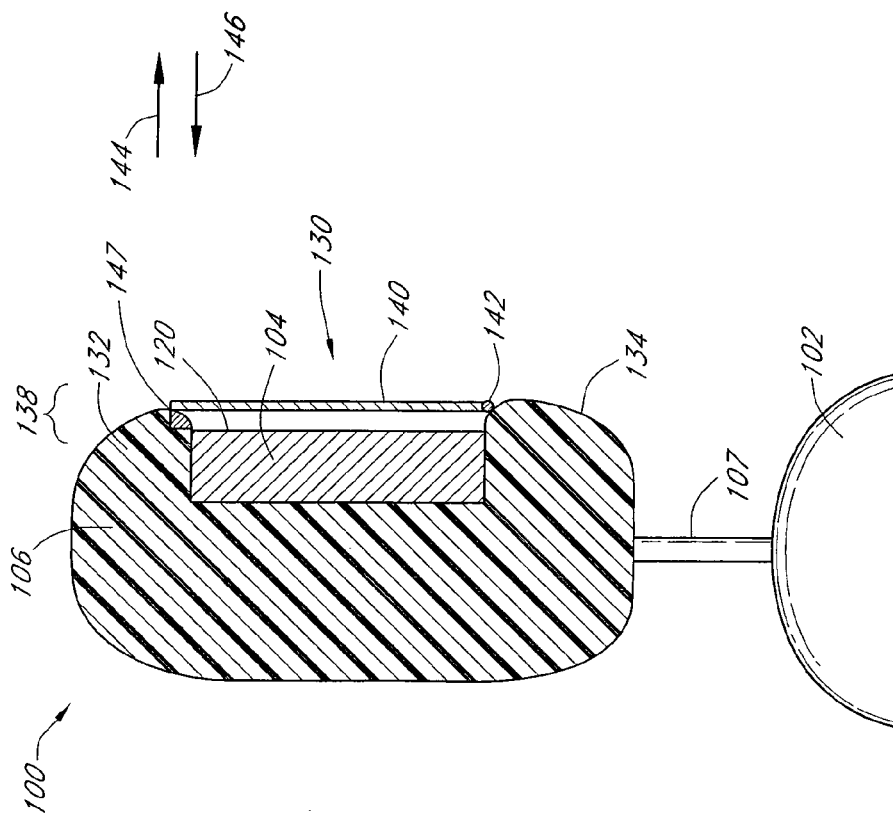

FIG. 3A

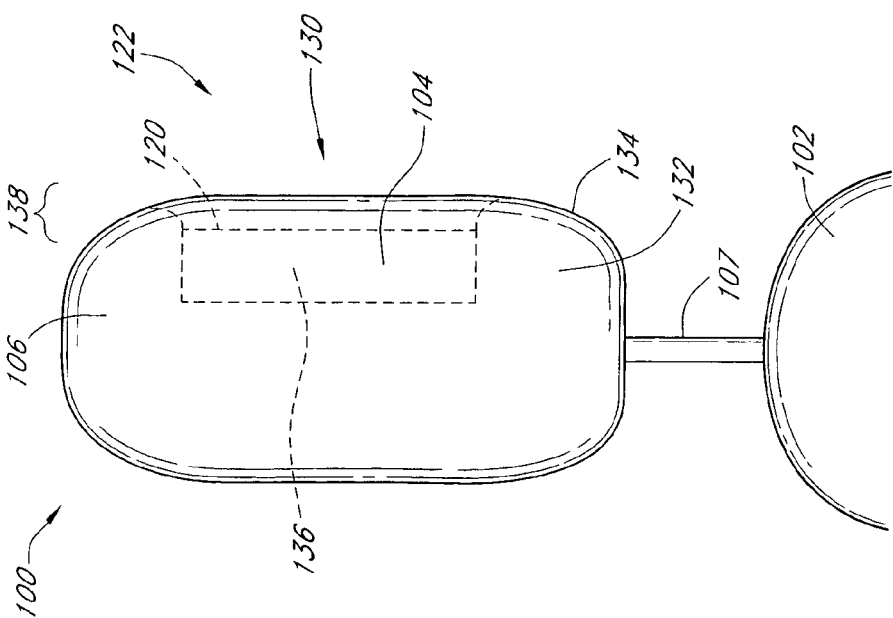

FIG. 2

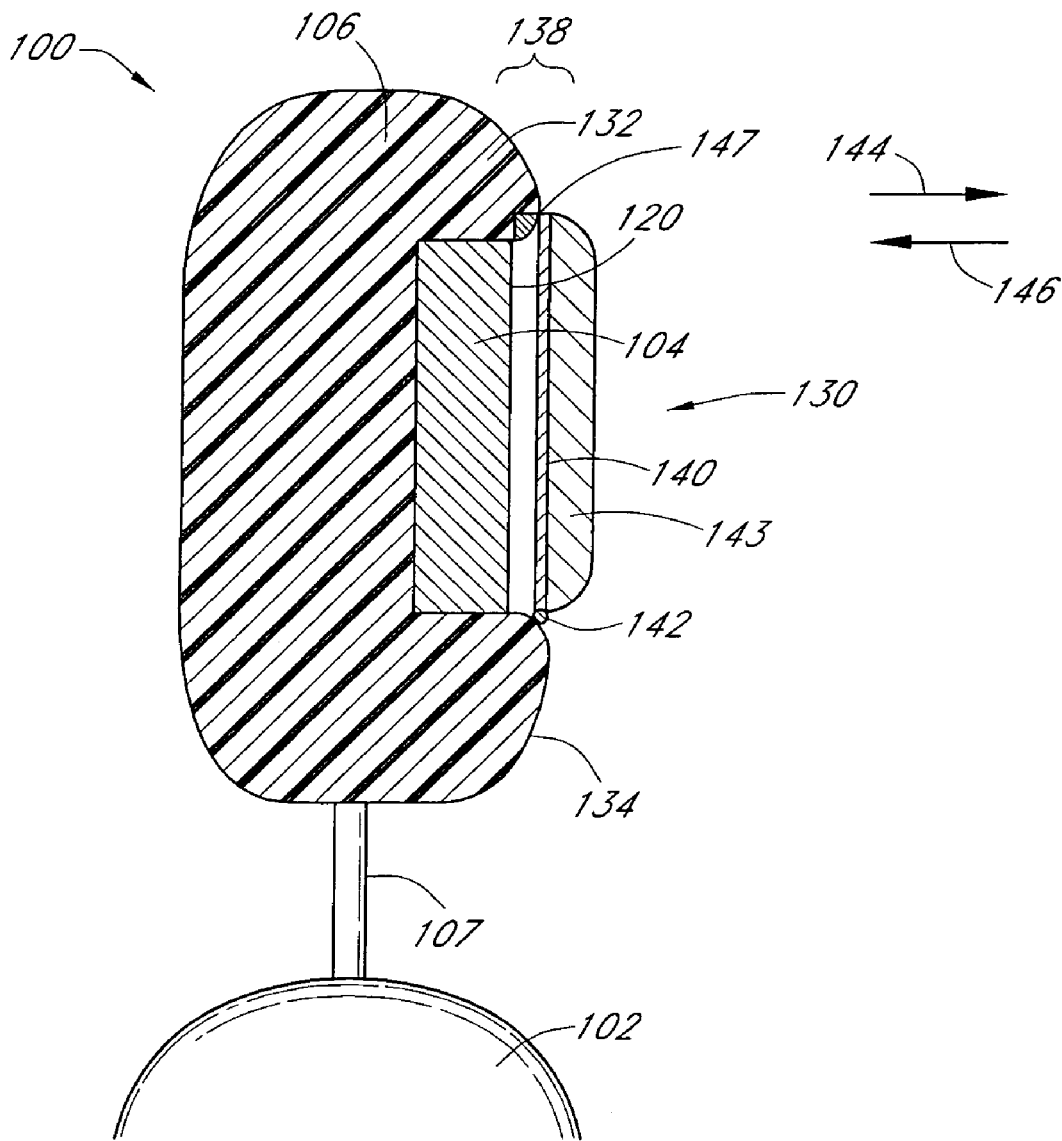

FIG. 3B

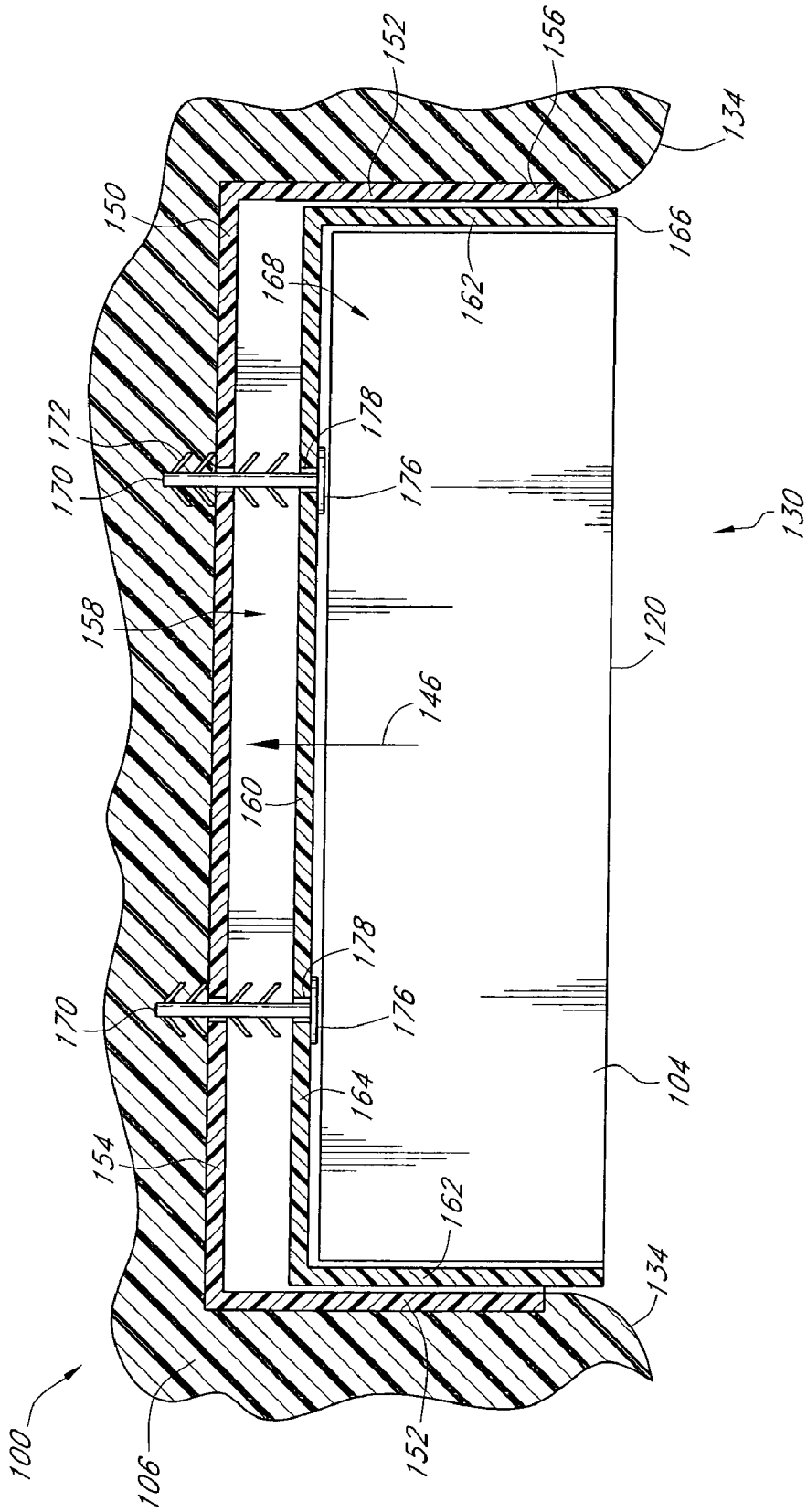

FIG. 4



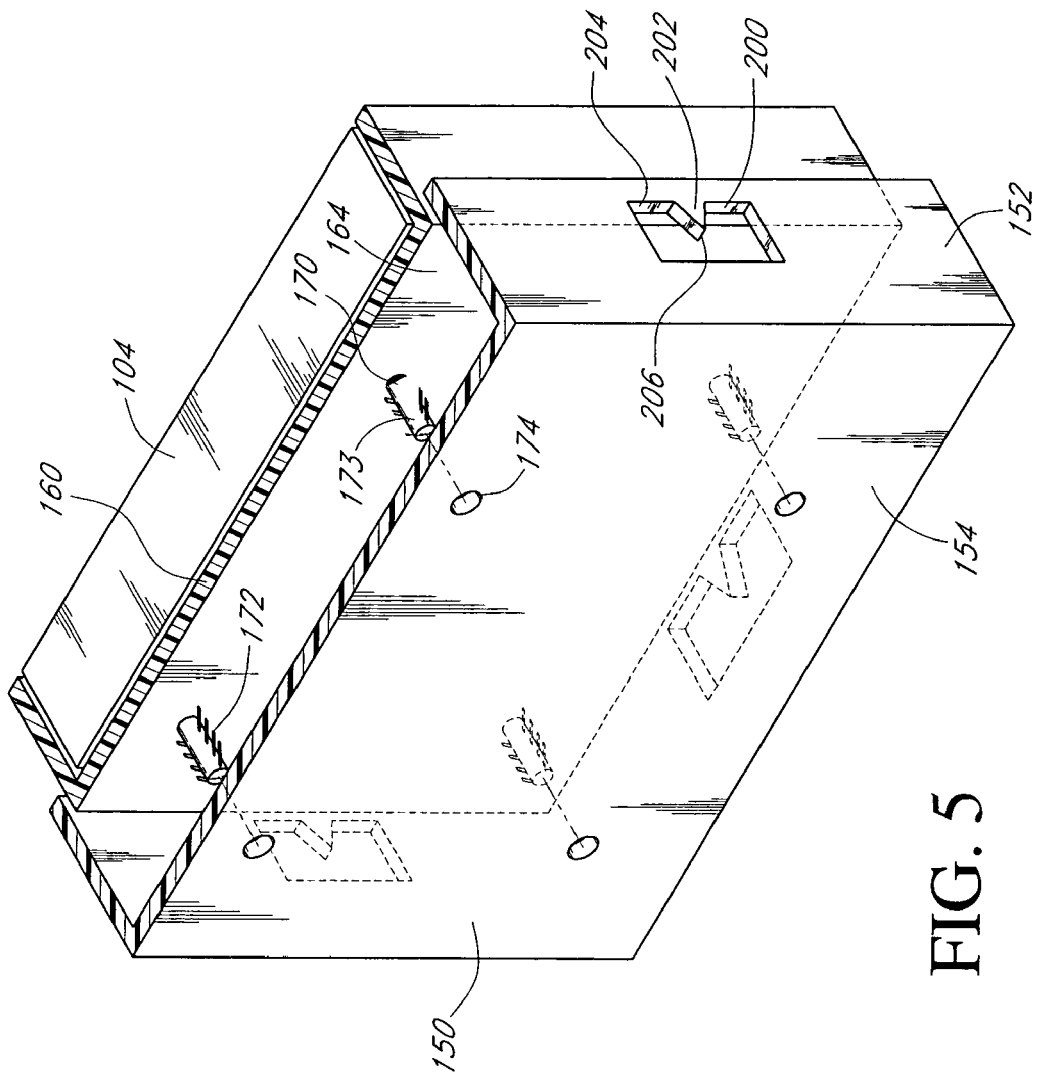

FIG. 5

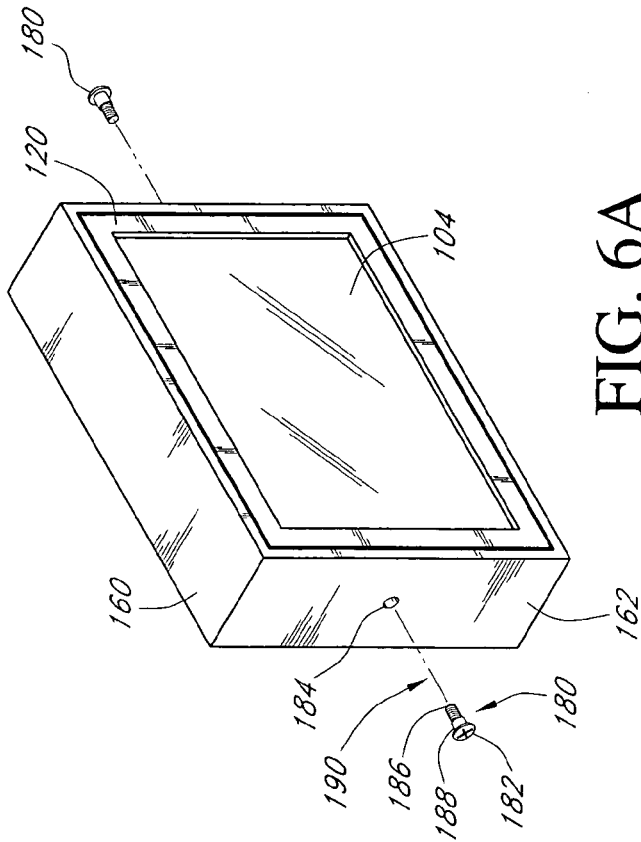

FIG. 6A

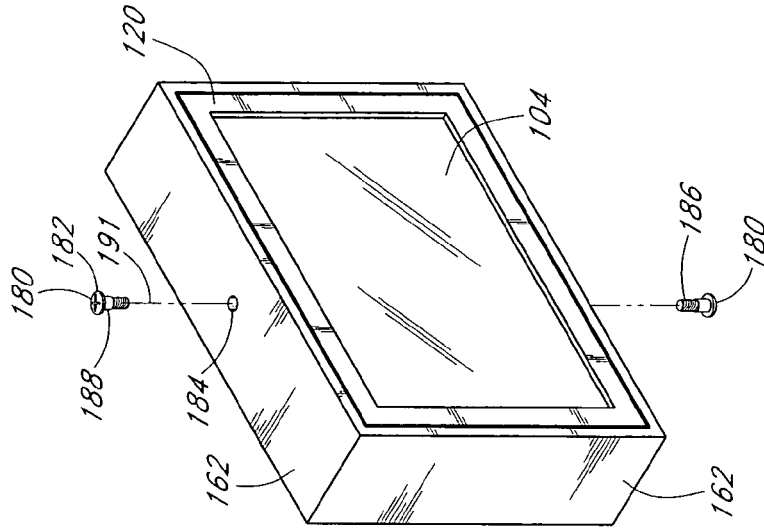

FIG. 6B

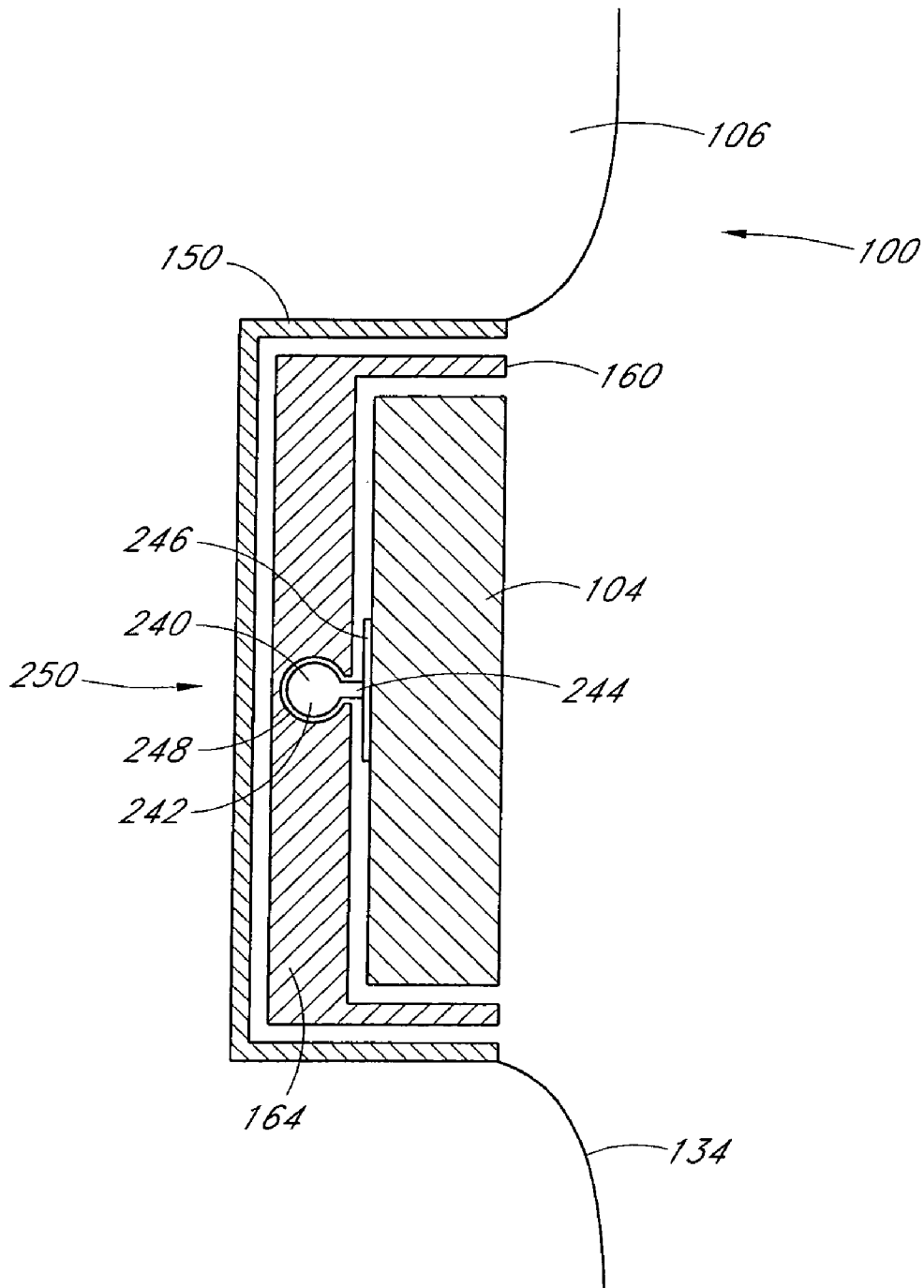

FIG. 6C

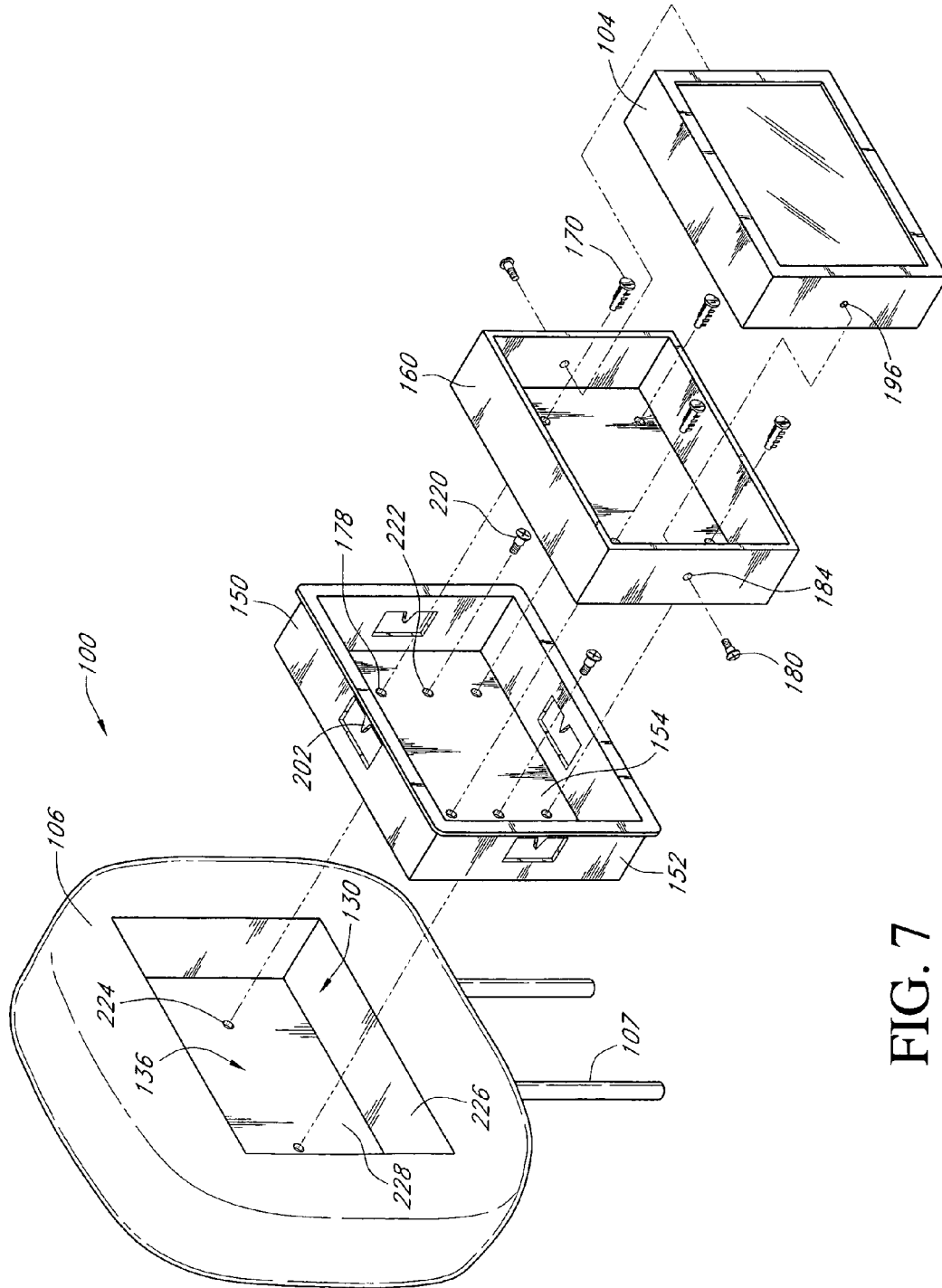

FIG. 7

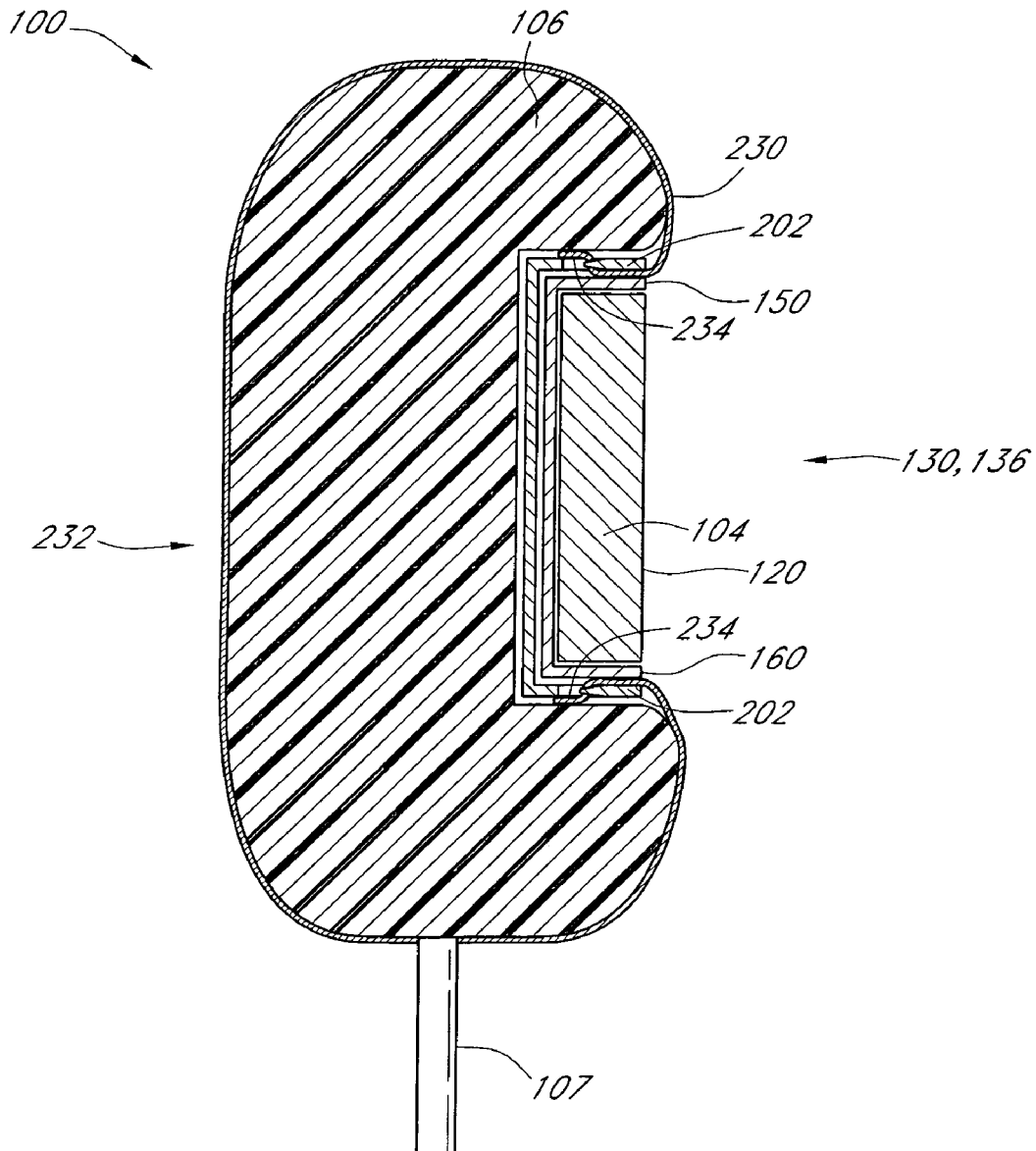

FIG. 8

US 7,040,697 B1

1

**HEADREST HAVING AN INTEGRATED  
VIDEO SCREEN**

## BACKGROUND OF THE INVENTION

## 1. Field of the Invention

The present invention relates to motor vehicles and, in particular, to a headrest for motor vehicle seats having an integrated video screen mounted therein.

## 2. Description of the Related Art

Seat back video monitors are becoming increasingly popular in vehicles. Originally, these entertainment systems were largely confined to airplanes, however, recently, these systems have become much more popular with cars, trucks and SUVs. These entertainment systems provide the opportunity for passengers to view entertainment or educational video programs during long trips.

Typically, these systems have been installed as aftermarket products where the seat back is modified to accept the video display device, however, more of these systems are being installed as original equipment. Unfortunately, existing systems are often difficult and labor intensive to mount, particularly as an aftermarket product and are also subject to being dislodged.

Generally, the devices are mounted on the outer surface of the seat back where they protrude. In many vehicles, the space between seats and seat backs is limited, hence the protruding video display unit can inhibit the ability of passengers to easily get into and out of the vehicles. Moreover, passenger contact with the protruding video display screen may result in the screens being inadvertently dislodged.

A further difficulty with many existing video display unit designs is that they are not well secured to the seat. This is particularly the case for designs that allow the video display unit to pivot about an axis to improve the viewing angle of the passenger. One common way that these display units are installed is that a bucket is installed into the seat and the peripheral rim of the bucket includes openings that receive pivot posts that extend outward from the housing of the display unit. The pivot posts are positioned within the openings and keepers or caps are then positioned in the openings to prevent the pivot posts from being removed from the openings.

In these designs, the keepers or caps are generally press fit and are exposed to the passenger. Hence, inadvertent contact may result in the keepers or caps being dislodged. Moreover, many of the passengers are children who, through boredom, may attempt to remove the keepers which can result in the video display being dislodged and potentially damaged.

Hence, from the foregoing, there is a need for a seat back video display system and method of mounting that provides more secure mounting of the video display unit. To this end, there is a need for an assembly that is less likely to be dislodged through inadvertent contact and does not have exposed detachable mounting components.

## SUMMARY OF THE INVENTION

The aforementioned needs may be satisfied by a seat back video display assembly adapted to be positioned in the back of a vehicle seat having an outer skin cover. In one aspect, the assembly may comprise a receptacle member having sidewalls and a back wall so as to define an opening, wherein the receptacle member is adapted to be positioned in the back of the vehicle seat. In addition the assembly may

2

further comprise a carrier member having sidewalls and a back wall so as to define an opening, wherein the carrier member includes at least one fastener that extends from the back wall of the carrier member and engages with the back wall of the receptacle member to secure the carrier member into the receptacle member, and a video display unit that is sized so as to be positioned secured within the opening in the carrier member, wherein the video display unit provides video signals.

Additionally, in one embodiment, the at least one fastener may comprise a plurality of fasteners that include a central member that extends outward from back wall of the carrier member and a plurality of flexible engagement members attached to the central member, wherein the flexible engagement members are deformable so as to allow insertion of the central member into the openings in the back wall of the receptacle member, and wherein the flexible engagement members are biased outward so as to inhibit removal of the central member from the openings in the back wall of the receptacle member. Also, the video display unit may be pivotally attached to the carrier member such that the plane of the video display unit can be adjusted by a user about a pivot point or axis, wherein the video display unit may be pivotable about a substantially horizontal pivot axis, a substantially vertical pivot axis, or pivot point that allows a continuous range of pivotal motion about the pivot point. Also, the openings may be positioned in the sidewalls of the receptacle member and the plurality of capture members are positioned within the openings, and wherein the plurality of capture members define a pointed surface that engages with the outer skin and inhibits removal of the outer skin from the opening defined by the receptacle member so as to securely fasten the outer skin to the receptacle member.

Additionally, in certain embodiments, the seat back video display assembly includes a screen cover that is dimensioned to cover the video display unit such that the screen cover can disengageably cover the screen of the video display unit to occlude the screen. The screen cover can include an impact attenuating material, a rigid protective layer, or any combination thereof.

The aforementioned needs may also be satisfied by a vehicle seat assembly having a seat back display. In one aspect, the vehicle seat assembly may comprise a vehicle seat adapted to receive an occupant during travel of a vehicle, the vehicle seat defining a seat back with an outer contour and a skin, and a receptacle member having sidewalls and a back wall to as to define an opening, wherein the receptacle member is mounted in the seat back of the vehicle seat such that the sidewalls are located at or below the outer contour of the seat back. In addition, the vehicle seat assembly may further comprise a video display unit mounted within the receptacle member, wherein the video display unit is generally planar with the outer plane being mounted at or below the outer contour of the seat back.

Moreover, the aforementioned needs may also be satisfied by a method of installing a video display unit into a seat back of a vehicle seat. In one embodiment, the method may comprise cutting an opening through an outer skin of the seat back, forming an aperture in the seat back, and positioning a receptacle in the aperture such that the receptacle is mounted at or below the level of the seat back. In addition, the method may comprise securing the video display unit to a carrier, and mounting the carrier into the receptacle such that an upper surface of the video display unit is mounted below the outer surface of the seat back. These and other objects and advantages of the present invention will become

US 7,040,697 B1

3

more fully apparent from the following description taken in conjunction with the accompanying drawings.

#### BRIEF DESCRIPTION OF THE DRAWINGS

FIG. 1A illustrates an adjustable headrest for a motor vehicle seat having an integrated video screen mounted therein.

FIG. 1B illustrates a fixed headrest for a motor vehicle seat having the integrated video screen of FIG. 1A mounted therein.

FIG. 2 illustrates a side view of the adjustable headrest shown in FIG. 1A having the integrated video screen mounted therein with a recessed orientation.

FIGS. 3A, 3B illustrate a cross-sectional view of the adjustable headrest shown in FIG. 1A having the integrated video screen mounted therein with a screen cover.

FIG. 4 illustrates a cross-sectional view of the integrated video screen being mounted to the headrest via a carrier receptacle, a carrier member, and a plurality of fasteners.

FIG. 5 illustrates a perspective view of the integrated video screen being mounted to the headrest via the carrier member and the plurality of fasteners of FIG. 4.

FIGS. 6A, 6B illustrate a perspective view of mounting the integrated video screen to the carrier member.

FIG. 6C illustrates a side view of mounting the integrated video screen to the carrier member via pivot member.

FIG. 7 illustrates a perspective view of mounting the integrated video screen to the adjustable headrest of FIG. 1A.

FIG. 8 illustrates a cross-sectional view of the video screen mounted to the headrest, wherein an outer skin from the headrest is secured to the carrier receptacle.

#### DETAILED DESCRIPTION OF THE PREFERRED EMBODIMENT

Reference will now be made to the drawings wherein like numerals refer to like parts throughout. A headrest for motor vehicle seats having an integrated video screen mounted therein in a flush or recessed manner will be described in greater detail herein below with reference to the drawings. In one aspect, it should be appreciated that the term motor vehicle seats refers to a plurality of generally known motor vehicles seats, such as those manufactured for automobiles, buses, boats, cars, semi-trucks, etc., wherein the following discussion can be similarly applied to these various types of motor vehicle seats without departing from scope of the present teachings. In addition, the following discussion refers to mounting the integrated video screen to the headrest of motor vehicle seats but may also be applied to other various component features of motor vehicle seats, such as the seat back, without departing from the scope of the present teachings.

FIG. 1A illustrates an adjustable headrest 100 for a first motor vehicle seat 102 having an integrated video screen 104 mounted therein. As illustrated in FIG. 1A, the adjustable headrest 100 is coupled to the seat 102 via posts 106 that extend therefrom and allow vertical adjustment of the adjustable headrest 100 with respect to the seat 102 in a generally known manner. FIG. 1B illustrates a fixed headrest 110 for a second motor vehicle seat 112 having the integrated video screen 104 mounted therein. In one embodiment, the video screen 104 is mounted within a headrest bun 106, 116 that is adapted to receive the video screen 104 for firm attachment therein in a manner that will be described in greater detail herein below. In addition, as will be described

4

in greater detail herein below, the video screen 102 is mounted such that a front surface 120 of the video screen 104 is either flush or recessed from a contour 122 of the headrest 100, 110.

In one embodiment, the video screen 104 comprises a generally known LCD (liquid crystal display) monitor or terminal that can be electrically coupled to a video entertainment system so as to receive video signals therefrom for viewing of movies, television, internet web pages, video games, etc. As illustrated, the video screen 104 is generally rectangular in shape with the planar front surface 120 that is viewable by a user. In one aspect, it should be appreciated that the degree of recessed depth (with no depth comprising a flush mount) of the integrated video screen 104 and the manner in which the contour 122 of the seat 102, 112 is shaped may be selected such that the shape (side view, for example) of the headrest 100, 110 with the integrated video screen 104 mounted therein is generally similar to the shape of the headrest 100, 110 without the integrated video screen 104. Moreover, it should be appreciated that the motor vehicle seats 102, 112 may comprise any one of a number of various types or models of generally known motor vehicle seats without departing from the scope of the present invention.

FIG. 2 illustrates a side view of the adjustable headrest 100 shown in FIG. 1A having the integrated video screen 104 mounted therein with a recessed orientation. It should be appreciated that the following discussion is with respect to the adjustable headrest 100 of FIG. 1A but may be similarly applied to the fixed headrest 110 of FIG. 1B without departing from the scope of the present teachings.

FIG. 2 further illustrates the side view shape or contour 122 of the headrest 100. As illustrated in FIG. 2, the contour 122 of the headrest 100 is maintained due to the recessed orientation of the video screen 104 within the headrest bun 106. In addition, an opening 130 is formed in a rear section 132 of the headrest 100 so as to define a substantially rectangular interior region 136 within the headrest bun 106 below an outer surface 134 of the headrest 100. As further illustrated in FIG. 2, the video screen 104 can then be positioned adjacent the opening 130 so as to be firmly positioned within the interior region 136 of the headrest bun 106. Moreover, the recessed orientation may be defined by a depth 138 between the front surface 120 of the video screen 104 and the outer surface 134 of the headrest 100. The depth 138 therebetween may vary in magnitude depending on the thickness of the headrest bun 106 and/or the internal structural characteristics of the headrest 100, which may vary with respect to the type or model of motor vehicle seat used. In one aspect, the depth 138 of the recessed orientation may comprise a magnitude of approximately zero so as to define a flush mounted video screen 104, wherein the front surface 1120 of the video screen 104 is substantially aligned with the outer surface 134 of the headrest 100.

FIG. 3A illustrates a cross-sectional view of the adjustable headrest 102 shown in FIGS. 1A having the integrated video screen 104 mounted therein with the recessed orientation shown in FIG. 2 and a screen cover 140. In one embodiment, the screen cover 140 is coupled to the rear section 132 of the headrest 100 via a hinge 142 so as to overlie the video screen 104 and at least part of the opening 130 formed therein. The screen cover 140 may comprise generally rectangular shape and is oriented generally parallel to the front surface 120 of the video screen 104 so as to temporarily occlude the video screen 104. In one aspect, as further illustrated in FIG. 3A, the screen cover 140 can be positioned adjacent the opening



US 7,040,697 B1

5

130 so as to substantially align with the outer surface 134 of the headrest 100 thus forming a flush mounting therewith. It should be appreciated that the screen cover 140 may be positioned within the opening 130 so as to be recessed with respect to the outer surface 134 of the headrest 100 without departing from the scope of the present teachings. Moreover, the screen cover 140 may comprise a rigid material, such as plastic, metal, etc. Alternatively, in another aspect, the screen cover 140 may comprise a piece or flap of material from an outer skin 230 (FIG. 8) of the motor vehicle seat 102 that is attached to the headrest 100 adjacent the lower side of the video screen 104.

In still another aspect, as illustrated in FIG. 3B, the screen cover 140 may comprise an impact attenuating section 143 comprising a material such as foam, various types of padding, an air cushion, etc. so as to soften the force of an impact from an object. For example, during a car accident, a person's head may be propelled towards the screen cover 140, wherein the impact attenuating material may soften the impact to the headrest 102 to thereby protect the person's head and the video screen 104 from damage.

Also, in one embodiment, the video screen 104 can be viewed by opening the screen cover 140 or temporarily occluded by closing the screen cover 140. Hence, the screen cover 140 can be outwardly rotated about the hinge 142 in a first direction 144 to openly view the video screen 104, or the screen cover 140 can be inwardly rotated about the hinge 142 in a second direction 144 opposite the first direction 144 to temporarily occlude the video screen 104. Advantageously, the screen cover 104, when closed, conceals the video screen 104 from view thus, in some situations, functions as a thief deterrent.

Moreover, in one aspect, the recessed configuration of the video screen 104 facilitates the manner in which the screen cover 140 may be deployed. For example, the video screen 104 may not physically interfere with the closing of the screen cover 140. In addition, as illustrated in FIGS. 3A, 3B, the screen cover 140 is intended to "hide" the video screen 104 from outside observers, thereby reducing the probability that the video screen 104 will be a target of theft. As further illustrated in FIGS. 3A, 3B, the screen cover 140 may further comprise a means for engagement 144 that allows the screen cover 140 to remain in the "up" or closed configuration. In general, it should be appreciated that some possible means for achieving such an engagement include but are not limited to magnetic strips, mechanical clips, velcro strips, and the like.

FIG. 4 illustrates a cross-sectional view of the integrated video screen 104 being mounted to the headrest 100 via a carrier receptacle 150, a carrier member 160, and first fasteners 170. FIG. 5 illustrates a perspective view of the integrated video screen 104 being mounted to the headrest 100 via the carrier receptacle 150, the carrier member 152, and the first fasteners 170. In one embodiment, the carrier receptacle 150 comprises a plurality of planar sidewalls 152 and a rear planar wall 154 that are joined together in a manner so as to form a substantially rectangular outer structure 156 having an inner recessed region 158 that is adapted to receive the carrier member 152 therein. Similarly, the carrier member 152 comprises a plurality of planar sidewalls 162 and a rear planar wall 164 that are joined together in a manner so as to form a substantially rectangular outer structure 166 having an inner recessed region 168 that is adapted to receive the video screen 104 therein.

As illustrated in FIG. 4, the video screen 104 may be mounted within the carrier member 160 via side fasteners 180 (shown in FIGS. 6A, 6B) and then the carrier member

6

152 is mounted within the carrier receptacle 150 via the first fasteners 170 so as to simplify the mounting of the video screen 104 to the headrest 100 including the headrest bun 106. In one aspect, the first fasteners 170 may comprise a plurality of flexible engagement members 172 that extend therefrom so as to mechanically couple with a plurality of mounting apertures 174 (FIG. 5) formed in the rear wall 154 of the carrier receptacle 150. The first fasteners 170 may further comprise a central member 173 that extends outward from the rear wall 164 of the carrier member 160. Also, the flexible engagement members 172 are attached to the central member 173, wherein the flexible engagement members 172 are deformable so as to allow insertion of the central member 173 into the mounting apertures 174 in the rear wall 164 of the receptacle member 150. Moreover, the flexible engagement members 170 are biased outward so as to inhibit removal of the central member 173 from the mounting apertures 174 in the rear wall 154 of the receptacle member 150. In addition, the first fasteners 170 comprise a head 176 that abuts the rear wall 164 of the carrier member 152 and is positioned through a plurality of second apertures 178 formed in the rear wall 164 of the carrier member 152.

Advantageously, the video screen 104 can be mounted to the headrest 100 via the carrier receptacle 150 and the carrier member 152 without using external fasteners that may be seen. Hence, the video screen 104 can be mounted to the headrest 100 in a more aesthetically appealing manner, wherein the front surface 120 of the video screen 104 recessed or flush mounted with respect to the outer surface 134 of the headrest 100, and wherein the first and second fasteners 170, 180 are concealed from view.

As illustrated in FIG. 5, the sidewalls 152 of the carrier receptacle 150 each comprise at least one sidewall aperture 200 having at least one serrated tooth 202 protruding from an interior sidewall 204. In one embodiment, the at least one serrated tooth 202 is triangular in shape having a pointed tip 206 that projects outward from the interior sidewall 204 in a horizontal manner. It should be appreciated that the serrated tooth 202 may comprise any one of a number of various shapes known in the art without departing from the scope of the present teachings. Additionally, as will be shown in FIG. 8, the pointed tip 234 engages with the outer skin 230 (FIG. 8) and inhibits removal of the outer skin 230 from the at least one sidewall aperture 200 formed in the carrier receptacle 150. Advantageously, as will be described in greater detail herein below, the serrated tooth 200 allows outer skin from the motor vehicle seat 102, 112 to be attached to the carrier receptacle 150 by wrapping the outer skin around the planar sidewalls 152 and into the recessed region 158 of the carrier receptacle 150 and then securing the outer skin to the serrated tooth 200.

FIG. 6A illustrates a perspective view of attaching the integrated video screen 104 to the carrier member 152 via the second fasteners 180. In one embodiment, the planar sidewalls 162 of the carrier member 160 comprise pivot apertures 184 that allow the video display 104 to be mounted to the carrier member 160. Also, the pivot apertures 184 are adapted to rotatably receive the second fasteners 180. As illustrated in FIG. 6A, the second fasteners 180 comprise a threaded region 186 that mechanically couples to threaded apertures 196 (FIG. 7) formed in the video screen 104 in a generally known manner so as to be securely attached thereto. Moreover, the second fasteners 180 further comprise a head 182 and a smooth pivot region 188 interposed between the threaded region and the head 182.

In one aspect, the pivot region 188 of the second fastener 180 rotatably communicates with the pivot aperture 184 of



US 7,040,697 B1

7

the carrier member **160** to thereby allow the video screen **104** to pivot or tilt with respect to the carrier member **160** and/or the headrest **100** along a horizontal pivot axis **190** defined by the horizontally mounted second fasteners **180**. Hence, the video screen **104** is pivotally attached to the carrier member **160** such that the plane of the video screen **104** can be adjusted with respect to the headrest **100** by a user about the defined horizontal pivot axis **190**. Advantageously, the horizontal pivot axis **190** allows the video screen **104** to readily pivot when mounted to the headrest **100** to thereby allow greater positional flexibility during viewing of the video screen **104** by a user.

FIG. 6B further illustrates a perspective view of attaching the integrated video screen **104** to the carrier member **152** via the second fasteners **180**. In one embodiment, as illustrated in FIG. 6B, the second fasteners **180** can be mounted vertically through the planar sidewalls **162** of the carrier member **160**. The pivot region **188** of the vertically mounted second fasteners **180** rotatably communicates with the pivot aperture **184** of the carrier member **160** to thereby allow the video screen **104** to pivot or tilt side-to-side with respect to the carrier member **160** and/or the headrest **100** along a vertical pivot axis **191** defined by the vertically mounted second fasteners **180**. Hence, the video screen **104** is pivotally attached to the carrier member **160** such that the plane of the video screen **104** can be adjusted with respect to the headrest **100** by a user about the vertical pivot axis **191**. Advantageously, the vertical pivot axis **191** allows the video screen **104** to readily pivot when mounted to the headrest **100** to thereby allow greater positional flexibility during viewing of the video screen **104** by a user.

In one aspect, it should be appreciated that the second fasteners **180** may comprise generally known screws, such as sheet metal screws, without departing from the scope of the present invention. It should also be appreciated that the pivot region **188** of the second fasteners **180** may be threaded in a manner such that the video screen **104** can still pivot with respect to the carrier member **150** without departing from the scope of the present invention.

FIG. 6C illustrates a view of attaching the integrated video screen **104** to the carrier member **152** via a pivot member **240**. In one embodiment, as illustrated in FIG. 6C, the pivot member **240** comprises a spherical ball **242** attached to the video screen **104** via a shaft **244** and a plate **246**. The spherical ball **242** is positioned within a spherical receptacle **248** formed in the rear wall **164** of the carrier member **160**. As illustrated in FIG. 6C, the rear wall **164** of the carrier member **160** may be dimensioned so as to accommodate the spherical receptacle **248**. In one aspect, the plate **246** of the pivot member **240** may be attached to the video screen **104** using an adhesive, such as epoxy or glue, or fasteners, such as screws or bolts. In addition, the shaft **244** distally extends from the plate **246** towards the spherical receptacle **248** of the carrier member **160**. Also, the shaft **244** and the spherical ball **242** may be formed as an integral part of the plate **246** or may be formed separately and interconnected to the plate **246** via an adhesive or fasteners.

Moreover, once the pivot member **240** is attached to the video screen **104** in a manner as previously described, the spherical ball **242** of the pivot member **240** can be pressed to fit within the spherical receptacle **248** formed in the rear wall **164** of the carrier member **160**. In one aspect, the spherical ball **242** may be sized at least less than the size of the spherical receptacle **248** so as to allow rotational movement therein. Advantageously, the resulting interconnection between the spherical ball **242** of the pivot member **240** and the spherical receptacle **248** of the carrier member **160**

8

defines a pivot point **250** to thereby allow the video screen **104** to pivot, tilt, or rotate in a multi-directional manner with respect to the defined pivot point **250**. Therefore, the defined pivot point **250** allows the video screen **104** to readily pivot when mounted to the headrest **100** to thereby allow greater positional flexibility during viewing of the video screen **104** by a user.

FIG. 7 illustrates a perspective view of mounting the integrated video screen **104** to the headrest **100** of FIG. 1A. In one embodiment, as illustrated in FIG. 7, the opening **130** is formed in the headrest bun **106** so as to define the substantially rectangular interior region **136** and to receive the carrier receptacle **150**. The carrier receptacle **150** can then be positioned within the opening **130** so that the planar sidewalls **152** and the planar rear wall **154** abut the interior walls **226** of the mounting recess **136** formed in the headrest bun **106**. In one embodiment, the carrier receptacle **150** can be secured to the headrest **100** via one or more third fasteners **220**, such as screws, machine screws, sheet metal screws, etc. As illustrated in FIG. 7, the third fasteners **220** are positioned through rear wall apertures **222** formed in the rear wall **154** of the carrier receptacle **150** and coupled to rear mounting apertures **224** formed in a back wall **226** of the mounting recess **136** of the headrest bun **106**. Advantageously, the third fasteners **220** can be securely attached to a structural component (not shown) of the headrest **100**, such as an internal framework member of the headrest **100**, so as to form a rigid attachment between the carrier receptacle **150** and the headrest **100**.

In addition, the video screen **104** may be mounted to the carrier member **160** so as to pivot with respect thereto in a manner as previously described with reference to FIGS. 6A, 6B, 6C. Following, the carrier member **160** including the video screen **104** can then be mounted to the carrier receptacle **150** via the first fasteners **170** in a manner as previously described with reference to FIG. 4. Advantageously, this method of attaching the video screen **104** to the headrest **100** via the carrier receptacle **150**, the carrier member **160**, and the fasteners **170**, **180** allows the video screen **104** to be securely mounted to the headrest **100** while providing a means for pivoting the video screen **104** with respect to the headrest **100** so as to improve the viewing range by a user.

FIG. 8 illustrates a cross-sectional view of the video screen **104** mounted to the headrest **100**, wherein the outer skin **230** of the headrest **100** of the motor vehicle seat **102** is attached to the carrier receptacle **150** and the carrier member **160** with the video screen **104** mounted therein is mounted within the mounting recess **136** of the carrier receptacle **150**. As is generally known, many motor vehicle car seats comprise the illustrated outer skin **230**, such as fabric, leather, upholstery, vinyl, etc., that provides a outer surface **232** for a user to lean against or rest upon. In one aspect, when mounting the integrated video screen **104** into the headrest **100** of the motor vehicle seat **102**, the outer skin **230** is adapted to accommodate the video screen **104** including the carrier receptacle **150**. In some situations, one or more flaps **234** can be formed in the outer skin **230** and attached to the one or more serrated teeth **202** formed in the planar sidewalls **152** of the carrier receptacle **150**.

As further illustrated in FIG. 8, the carrier receptacle **150** may be positioned within the mounting recess **136** formed in the headrest bun **106**, and then the outer skin **230** is secured to the serrated teeth **202** via the flaps **234** formed therein by hooking the flaps **234** to one or more of the serrated teeth **202**. Once the outer skin **230** is attached to the serrated teeth **202** via the flaps **234**, the carrier member **160** is firmly pressed within the mounting recess **136** of the headrest bun

US 7,040,697 B1

9

106 so that the first fasteners 170 couple to the mounting apertures 174 formed in the rear wall 154 of the carrier receptacle 150.

Advantageously, this interconnection between the carrier member 160 and carrier receptacle 150 provides a quick and easy means for mounting of the video screen 104 to the headrest 100. In addition, the pressed fit of the outer skin between the carrier member 160 and the carrier receptacle 150 further secures the outer skin of the motor vehicle seat 102 to the carrier receptacle 150. As a result, the outer skin is securely held to the carrier receptacle 150 via the one or more serrated teeth 202 formed in the planar sidewalls 152 of the carrier receptacle 150 and the pressed fit of the carrier member 160 within the mourning recess 136 of the carrier receptacle 150.

Although the foregoing description has shown, described and pointed out the fundamental novel features of the invention, it will be understood that various omissions, substitutions, and changes in the form of the detail of the apparatus as illustrated, as well as the uses thereof, may be made by those skilled in the art, without departing from the spirit or scope of the present invention. Consequently, the scope of the invention should not be limited to the foregoing discussion, but should be defined by the appended claims.

What is claimed is:

1. A seat back video display assembly adapted to be positioned in a back of a vehicle seat having an outer skin, the assembly comprising:

a receptacle member having sidewalls and a back wall so as to define an opening wherein the receptacle member is adapted to be positioned in the back of the vehicle seat wherein the opening is facing away from the back of the vehicle seat when the receptacle member is positioned within the back of the vehicle seat and wherein the receptacle member includes at least one securing opening formed in the back wall of the receptacle member;

a carrier member having sidewalls and a back wall so as to define an opening, wherein the carrier member includes at least one fastener that is coupled to the back wall that extends from the back wall of the carrier member and engages with the at least one securing opening in the back wall of the receptacle member to secure the carrier member into the receptacle member and wherein the opening in the carrier member is facing away from the back of the vehicle seat when the carrier member is positioned within the receptacle member; and

a video display unit that is sized so as to be positioned secured within the opening in the carrier member and substantially conceal the at least one fastener, wherein the video display unit provides video signals wherein the video display unit is pre-assembled into the carrier member so that the combined video display unit and the carrier member can be simultaneously secured within the receptacle member by positioning the carrier member in the receptacle member such that the back wall of the carrier member is flush with the back wall of the receptacle member and the at least one fastener of the carrier member is pushed through the at least one securing opening.

2. The assembly of claim 1, wherein the receptacle member includes a plurality of openings positioned within the back wall that receive the fasteners of the carrier member.

3. The assembly of claim 2, wherein the at least one fastener comprises a plurality of fasteners that include a

10

central member that extends outward from back wall of the carrier member and a plurality of flexible engagement members attached to the central member, wherein the flexible engagement members are deformable so as to allow insertion of the central member into the openings in the back wall of the receptacle member, and wherein the flexible engagement members are biased outward so as to inhibit removal of the central member from the openings in the back wall of the receptacle member.

4. The assembly of claim 1, wherein the video display unit defines a plane and is pivotally attached to the carrier member such that the plane of the video display unit can be adjusted by a user about a pivot axis.

5. The assembly of claim 4, wherein the video display unit is pivotable about a substantially horizontal axis.

6. The assembly of claim 4, wherein at least a first and second fasteners are positioned through the carrier into the display unit so as to secure the video display unit to the carrier member prior to installation of the carrier into the receptacle member, and wherein the at least first and second fasteners engage with the video display unit so as to define a pivot axis.

7. The assembly of claim 1, wherein the receptacle member includes an outer lip and a plurality of outer skin capture members that engage with the outer skin of the seat back following installation such that the outer skin is extended over the outer lip of the receptacle member and secured to the outer skin capture members.

8. The assembly of claim 7, wherein openings are positioned in the sidewalls of the receptacle member and the plurality of capture members are positioned within the openings, and wherein the plurality of capture members define a pointed surface that engages with the outer skin and inhibits removal of the outer skin from the opening defined by the receptacle member.

9. The assembly of claim 1, further comprising a screen cover that is dimensioned to cover the video display unit in a first configuration following installation into the seat back, and wherein the cover is selectively disengagable so as to allow visual access to the video display unit.

10. The assembly of claim 9, wherein the cover includes an impact attenuating material.

11. The assembly of claim 9, wherein the cover includes a generally rigid layer to provide physical protection of the video display unit.

12. A vehicle seat assembly having a seat back display, the assembly comprising:

a vehicle seat adapted to receive an occupant during travel of a vehicle, the vehicle seat defining a seat back with an outer contour and an outer skin;

a receptacle member having sidewalls and a back wall so as to define an opening, wherein the receptacle member is mounted in the seat back of the vehicle seat such that the sidewalls are located at or below the outer contour of the seat back and wherein the receptacle member includes at least one opening in the side walls and at least one outer skin capture member having a pointed surface positioned within the at least one opening such that the at least one outer skin capture member captures the outer skin of the seat back to inhibit removal of the outer skin from the at least one opening; and

a video display unit mounted within the receptacle member, wherein the video display unit is generally planar with an outer plane that is at or below the outer contour of the vehicle seat.

13. The assembly of claim 12, further comprising a carrier member having sidewalls and a back wall so as to define an

US 7,040,697 B1

11

opening, wherein the carrier member includes at least one fastener that extends from the back wall of the carrier member and engages with the back wall of the receptacle member to secure the carrier member into the receptacle member, and wherein the video display unit is positioned within the carrier unit.

14. The assembly of claim 13, wherein the receptacle member includes a plurality of openings positioned within the back wall that receive the fasteners of the carrier member.

15. The assembly of claim 14, wherein the at least one fastener comprises a plurality of fasteners that include a central member that extends outward from back wall of the carrier member and a plurality of flexible engagement members attached to the central member, wherein the flexible engagement members are deformable so as to allow insertion of the central member into the openings in the back wall of the receptacle member, and wherein the flexible engagement members are biased outward so as to inhibit removal of the central member from the openings in the back wall of the receptacle member.

16. The assembly of claim 13, wherein the video display unit is pivotally attached to the carrier member such that the outer plane of the video display unit can be adjusted by a user about a pivot axis.

17. The assembly of claim 16, wherein the video display unit is pivotable about a substantially horizontal axis.

18. The assembly of claim 16, wherein at least a first and second fasteners are positioned through the carrier into the display unit so as to secure the video display unit to the

12

carrier member prior to installation of the carrier into the receptacle member, and wherein the at least first and second fasteners engage with the video display unit so as to define a pivot axis.

19. The assembly of claim 12, further comprising a screen cover that is dimensioned to cover the video display unit in a first configuration following installation into the seat back, and wherein the cover is selectively disengagable so as to allow visual access to the video display unit.

20. The assembly of claim 19, wherein the screen cover comprises at least a portion of the outer skin that is attached to the seat back adjacent a bottom side of the video display unit and a fastener assembly attached to the portion of outer skin and the seat back adjacent a top side of the video display unit such that the portion of outer skin can hide the video display unit from view.

21. The assembly of claim 19, wherein the screen cover includes an impact attenuating material selected from the group consisting of foam, padding, and an air cushion.

22. The assembly of claim 19, wherein the screen cover includes a generally rigid layer to provide physical protection of the video display unit.

23. The assembly of claim 12, wherein the outer skin is selected from the group consisting of fabric, leather, upholstery, and vinyl.

24. The assembly of claim 12, wherein the vehicle seat includes a head rest and the receptacle member is positioned within the head rest.

\* \* \* \* \*

# **EXHIBIT B**



US007407227B1

(12) **United States Patent**  
**Tuccinardi et al.**

(10) **Patent No.:** **US 7,407,227 B1**  
(45) **Date of Patent:** **\*Aug. 5, 2008**

(54) **HEADREST HAVING AN INTEGRATED VIDEO SCREEN**

4,584,603 A 4/1986 Harrison  
4,635,110 A 1/1987 Weinblatt  
4,647,980 A 3/1987 Steventon et al.

(75) Inventors: **Eugene M. Tuccinardi**, Temecula, CA (US); **Ernesto R. Haack**, Perris, CA (US); **Robert Murphy**, Lake Elsinore, CA (US); **Frank Barrese**, Temecula, CA (US); **Roel C. Espina**, Loma Linda, CA (US); **Jon A. Molo**, Ontario (CA); **Theo Zoetemelk**, Riverside, CA (US)

(Continued)

**FOREIGN PATENT DOCUMENTS**

DE 3637772 A1 5/1988

(Continued)

**OTHER PUBLICATIONS**

WO 02/074577. Jost, Gilbert. Headrest, Particularly for a Motor Vehicle Seat, Sep. 26, 2002.\*

(Continued)

*Primary Examiner*—Sarah B McPartlin

(74) *Attorney, Agent, or Firm*—Knobbe, Martens, Olson & Bear, LLP

(73) Assignee: **Timely Innovations, L.P.**, Temecula, CA (US)

(\* ) Notice: Subject to any disclaimer, the term of this patent is extended or adjusted under 35 U.S.C. 154(b) by 0 days.

This patent is subject to a terminal disclaimer.

(21) Appl. No.: **11/415,696**

(57) **ABSTRACT**

(22) Filed: **May 2, 2006**

A seat back video display assembly adapted to be positioned in the back of a vehicle seat having an outer skin cover. In one aspect, the assembly may comprise a receptacle member having sidewalls and a back wall so as to define an opening wherein the receptacle member is adapted to be positioned in the back of the vehicle seat. In addition, the assembly may further comprise a carrier member having sidewalls and a back wall so as to define an opening, wherein the carrier member includes at least one fastener that extends from the back wall of the carrier member and engages with the back wall of the receptacle member to secure the carrier member into the receptacle member. Moreover, the assembly may still further comprise a video display unit that is sized so as to be positioned secured within the opening in the carrier member, wherein the video display unit provides video signals.

**Related U.S. Application Data**

(63) Continuation of application No. 10/395,870, filed on Mar. 20, 2003, now Pat. No. 7,040,697.

(51) **Int. Cl.**  
*A47C 7/62* (2006.01)

(52) **U.S. Cl.** ..... 297/217.3; 297/188.04

(58) **Field of Classification Search** ..... 297/217.3, 297/188.04, 188.07, 408, 391; 5/643, 645  
See application file for complete search history.

(56) **References Cited**

**U.S. PATENT DOCUMENTS**

3,004,815 A 10/1961 O’Kain et al.

**14 Claims, 10 Drawing Sheets**

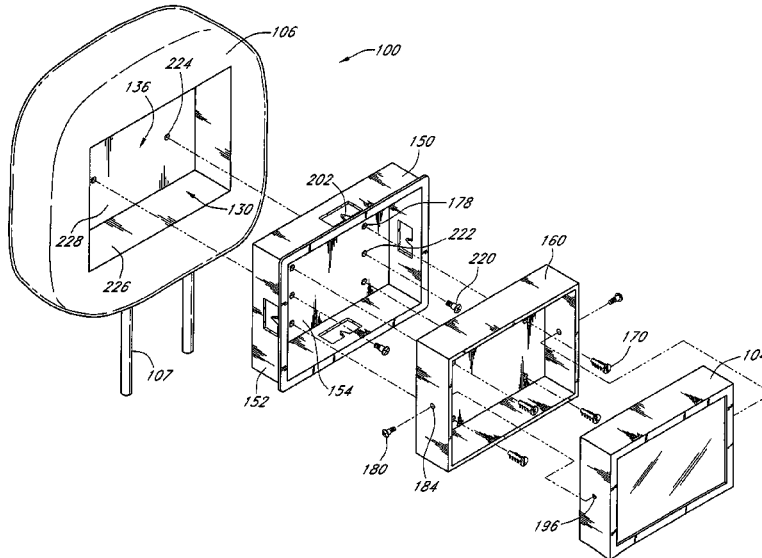

**US 7,407,227 B1**

U.S. PATENT DOCUMENTS

4,681,366 A \* 7/1987 Lobanoff ..... 297/188.06  
 4,756,528 A 7/1988 Umashankar  
 4,776,739 A \* 10/1988 Hamman ..... 411/510  
 4,788,588 A 11/1988 Tomita  
 4,866,515 A 9/1989 Tagawa et al.  
 RE33,423 E 11/1990 Lobanoff  
 4,983,951 A 1/1991 Igarashi et al.  
 5,267,775 A \* 12/1993 Nguyen ..... 297/217.3  
 5,292,174 A 3/1994 Ohnuma  
 5,293,244 A 3/1994 Kawaguchi  
 5,311,302 A 5/1994 Berry et al.  
 5,333,416 A 8/1994 Harris et al.  
 5,359,349 A 10/1994 Jambor et al.  
 5,507,556 A \* 4/1996 Dixon ..... 297/217.3  
 5,529,265 A 6/1996 Sakurai  
 5,555,466 A 9/1996 Scribner et al.  
 5,640,297 A 6/1997 Labaze  
 5,713,633 A 2/1998 Lu  
 D398,921 S 9/1998 Rosen  
 5,842,715 A 12/1998 Jones  
 5,953,784 A \* 9/1999 Suzuki et al. .... 15/209.1  
 6,024,027 A 2/2000 Esmaili  
 6,055,478 A 4/2000 Heron  
 D434,400 S 11/2000 Rosen  
 6,199,948 B1 3/2001 Bush et al.  
 6,216,927 B1 4/2001 Meritt  
 6,250,967 B1 6/2001 Chu  
 6,292,236 B1 9/2001 Rosen  
 6,305,046 B1 \* 10/2001 Kingry et al. .... 15/231  
 6,339,455 B1 1/2002 Allan et al.  
 6,394,551 B1 5/2002 Beukema  
 6,406,334 B2 6/2002 Chu  
 6,409,242 B1 6/2002 Chang  
 6,480,243 B2 11/2002 Yamamoto  
 6,669,285 B1 \* 12/2003 Park et al. .... 297/217.3  
 6,739,654 B1 5/2004 Shen et al.  
 6,750,599 B2 6/2004 Tajima  
 6,755,491 B2 6/2004 McElheney  
 6,762,929 B2 7/2004 Sawyer  
 6,883,870 B2 \* 4/2005 Jost ..... 297/391  
 7,036,879 B2 5/2006 Chang  
 7,038,581 B2 5/2006 Kendall et al.

7,040,697 B1 \* 5/2006 Tuccinardi et al. .... 297/217.3  
 7,044,546 B2 5/2006 Chang  
 2001/0008266 A1 7/2001 Lambert  
 2003/0025367 A1 \* 2/2003 Boudinot ..... 297/217.3  
 2004/0007906 A1 1/2004 Park et al.  
 2004/0032543 A1 \* 2/2004 Chang ..... 348/837  
 2004/0160096 A1 8/2004 Boudinot  
 2005/0099042 A1 5/2005 Vitito  
 2005/0242638 A1 11/2005 Vitito  
 2007/0001492 A1 1/2007 Chang  
 2007/0102973 A1 5/2007 Vitito

FOREIGN PATENT DOCUMENTS

DE 19601582 A1 1/1996  
 FR 2764563 A1 12/1998  
 JP 01094048 A2 4/1989

OTHER PUBLICATIONS

Office Action of Jul. 27, 2007 for U.S. Appl. No. 10/819,341.  
 Response to Office Action of Jul. 27, 2007 for U.S. Appl. No. 10/819,341.  
 Office Action of Jan. 31, 2007 for U.S. Appl. No. 11/415,918.  
 Response to Restriction Requirement of May 10, 2007 for U.S. Appl. No. 10/819,341.  
 Restriction Requirement of May 10, 2007 for U.S. Appl. No. 10/819,341.  
 Response to Office Action of Jan. 31, 2007 for U.S. Appl. No. 11/415,918.  
 Final Office Action of Jul. 30, 2007 for U.S. Appl. No. 11/415,918.  
 RCE and Response to Final Office Action of Jul. 30, 2007 for U.S. Appl. No. 11/415,918.  
 Restriction Requirement of Jul. 19, 2004 for U.S. Appl. No. 10/395,870.  
 Response to Restriction Requirement of Jul. 19, 2004 for U.S. Appl. No. 10/395,870.  
 Office Action of Sep. 27, 2004 for U.S. Appl. No. 10/395,870.  
 Response to Office Action of Sep. 27, 2004 for U.S. Appl. No. 10/395,870.  
 Final Office Action of May 3, 2005 for U.S. Appl. No. 10/395,870.  
 RCE & Response to Final Action of May 3, 2005 for U.S. Appl. No. 10/395,870.  
 Notice of Allowance of Dec. 6, 2005 for U.S. Appl. No. 10/395,870.

\* cited by examiner

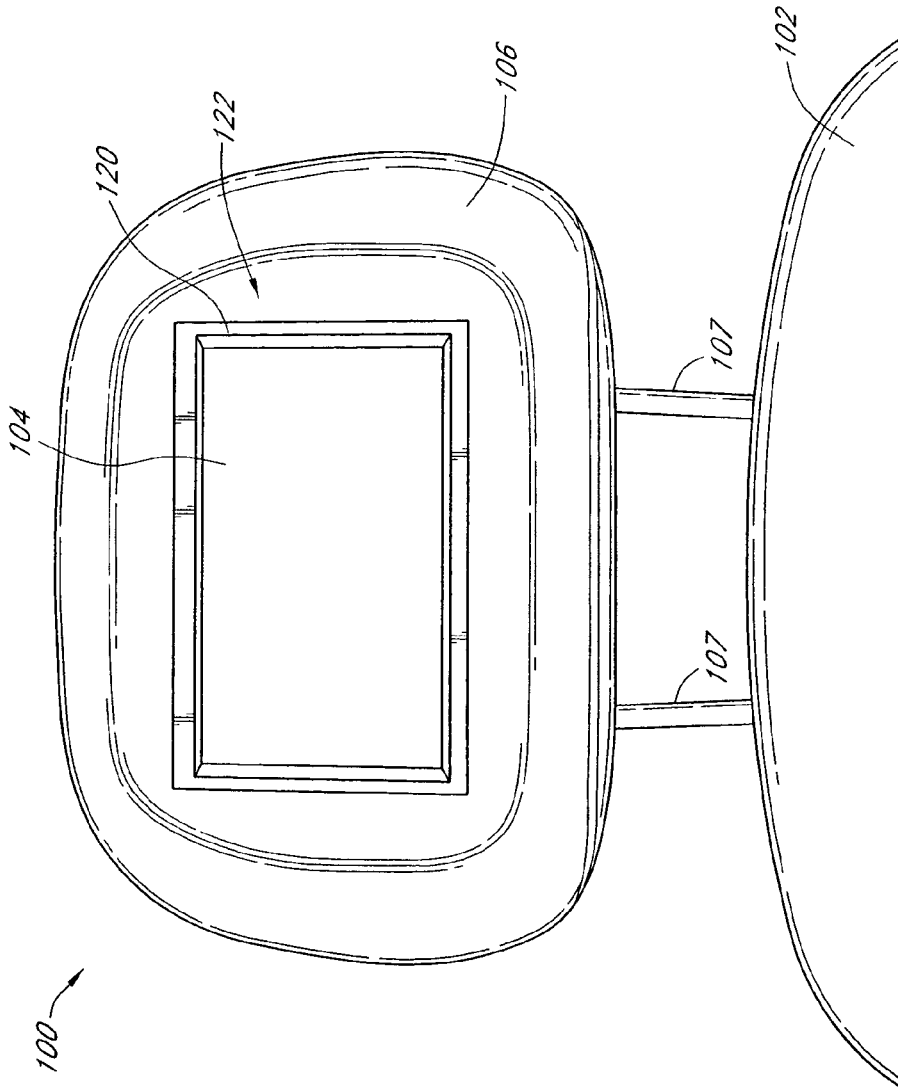

FIG. 1A

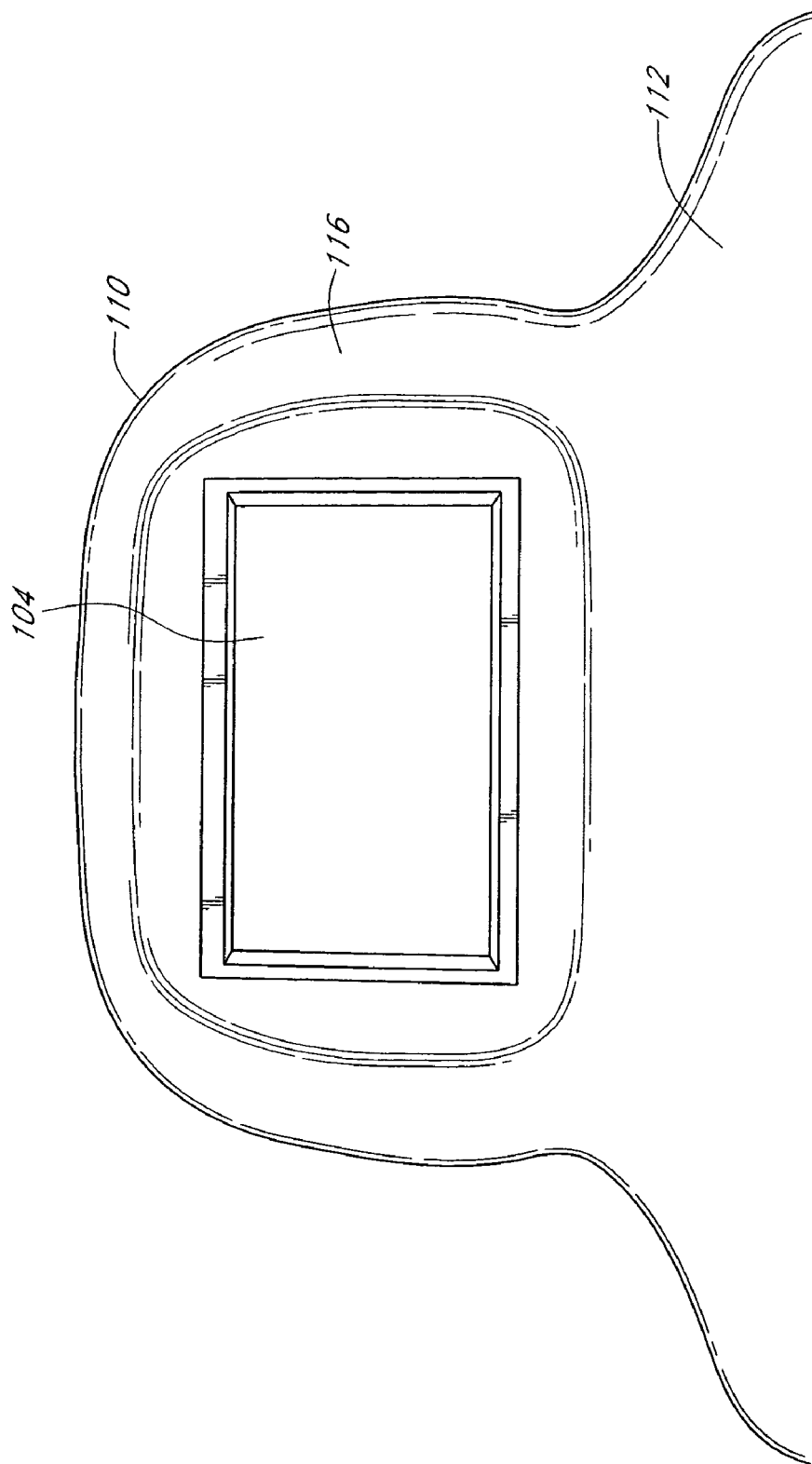

FIG. 1B



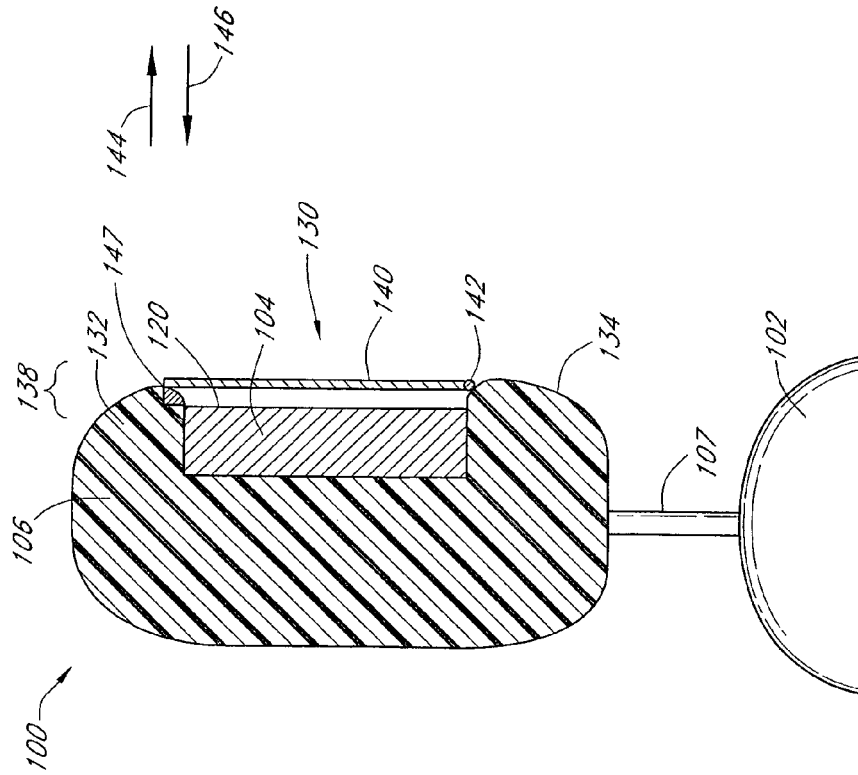

FIG. 3A

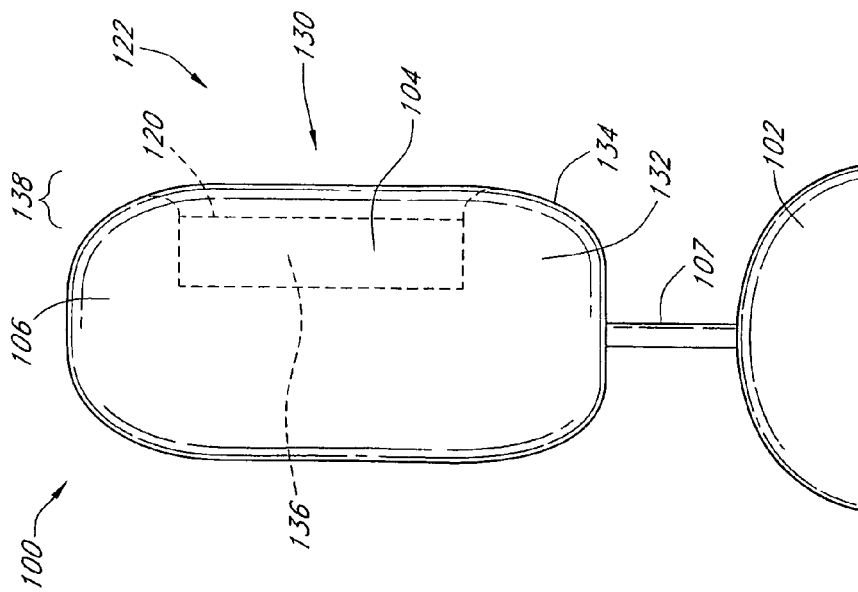

FIG. 2

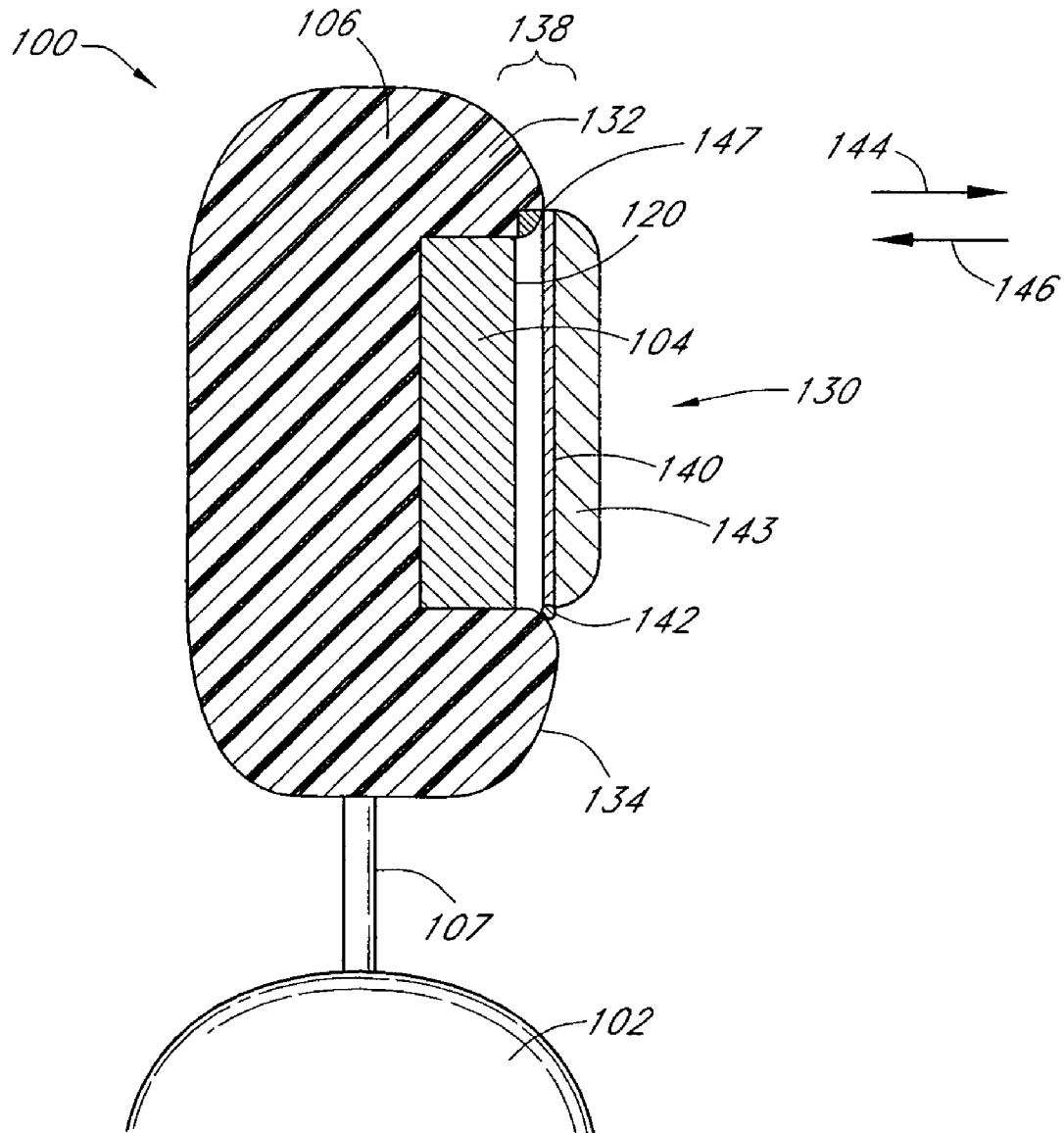

FIG. 3B

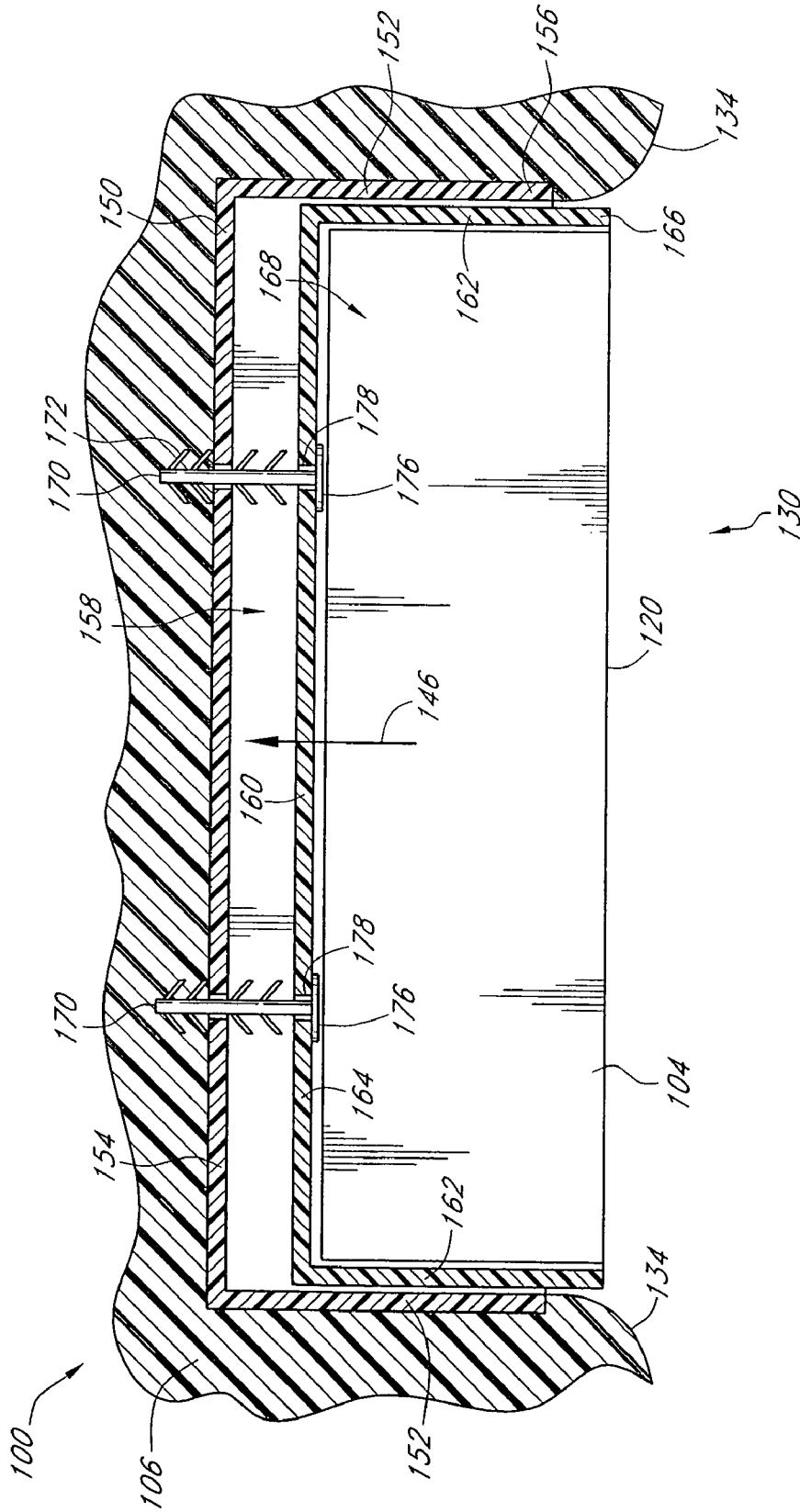

FIG. 4

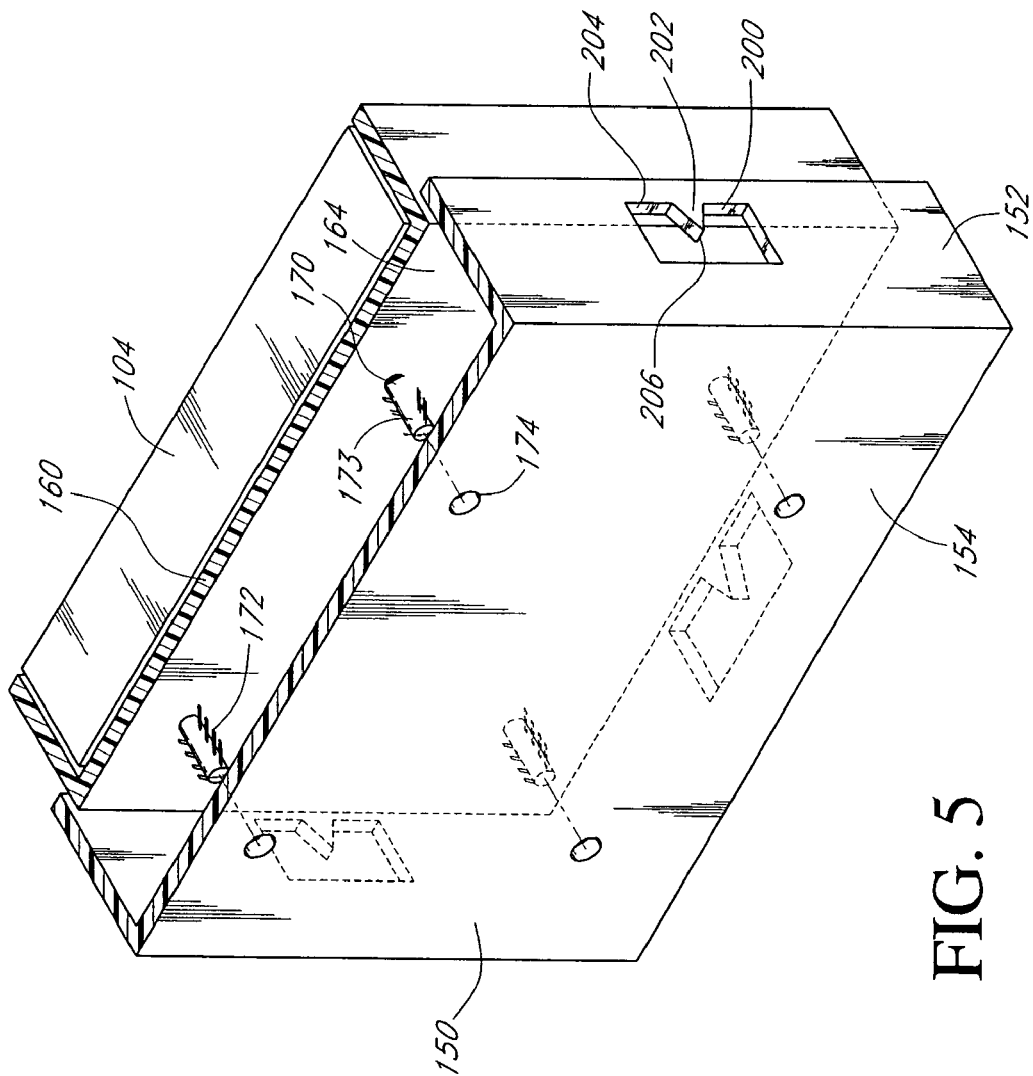

FIG. 5

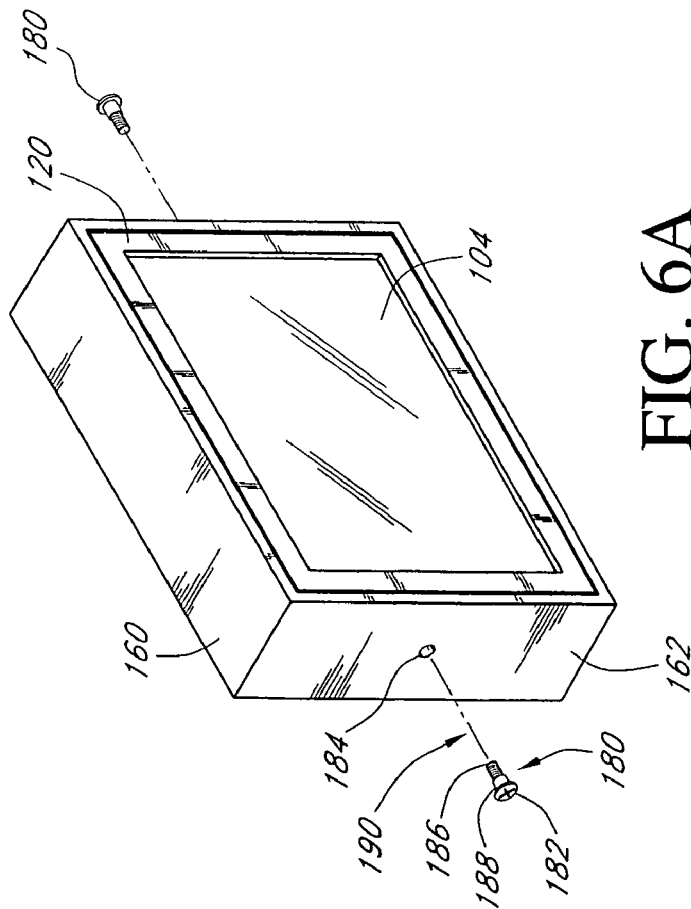

FIG. 6A

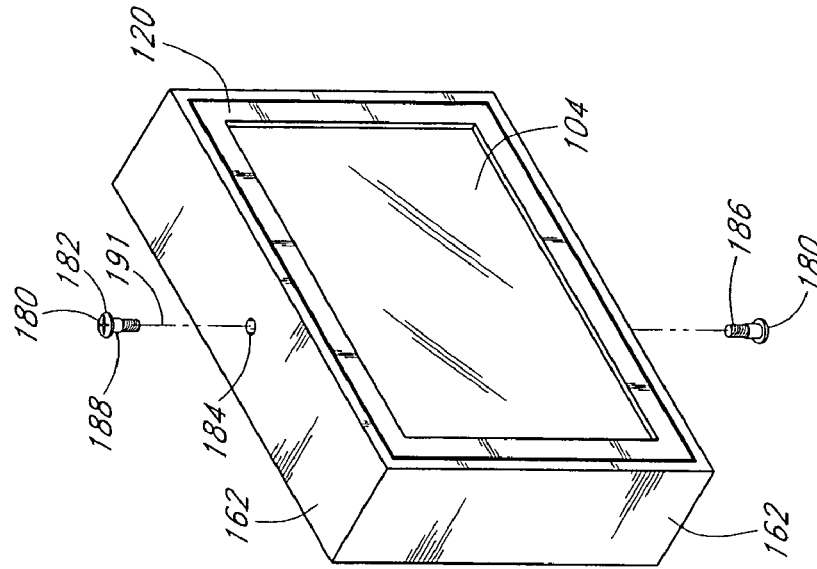

FIG. 6B

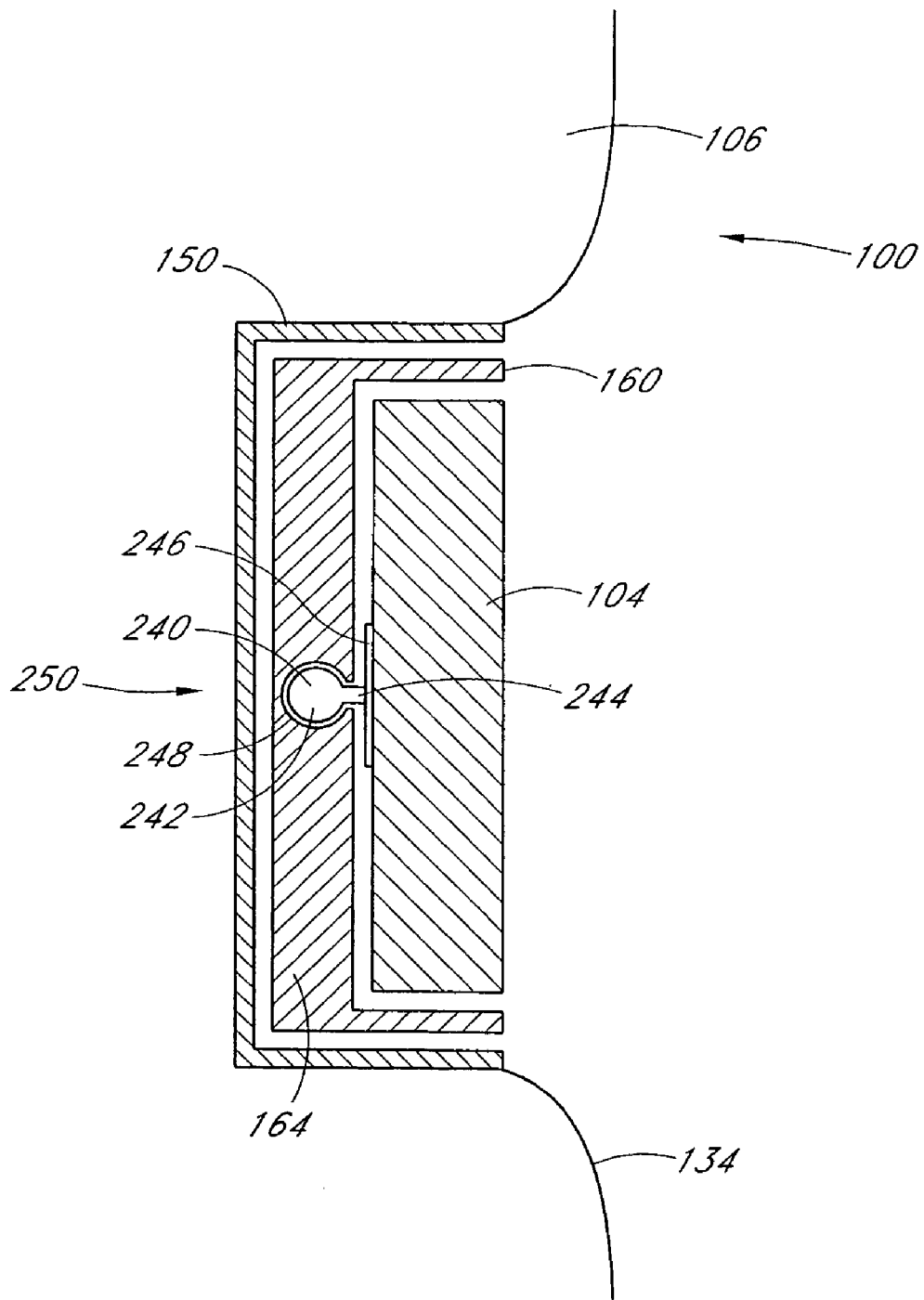

FIG. 6C

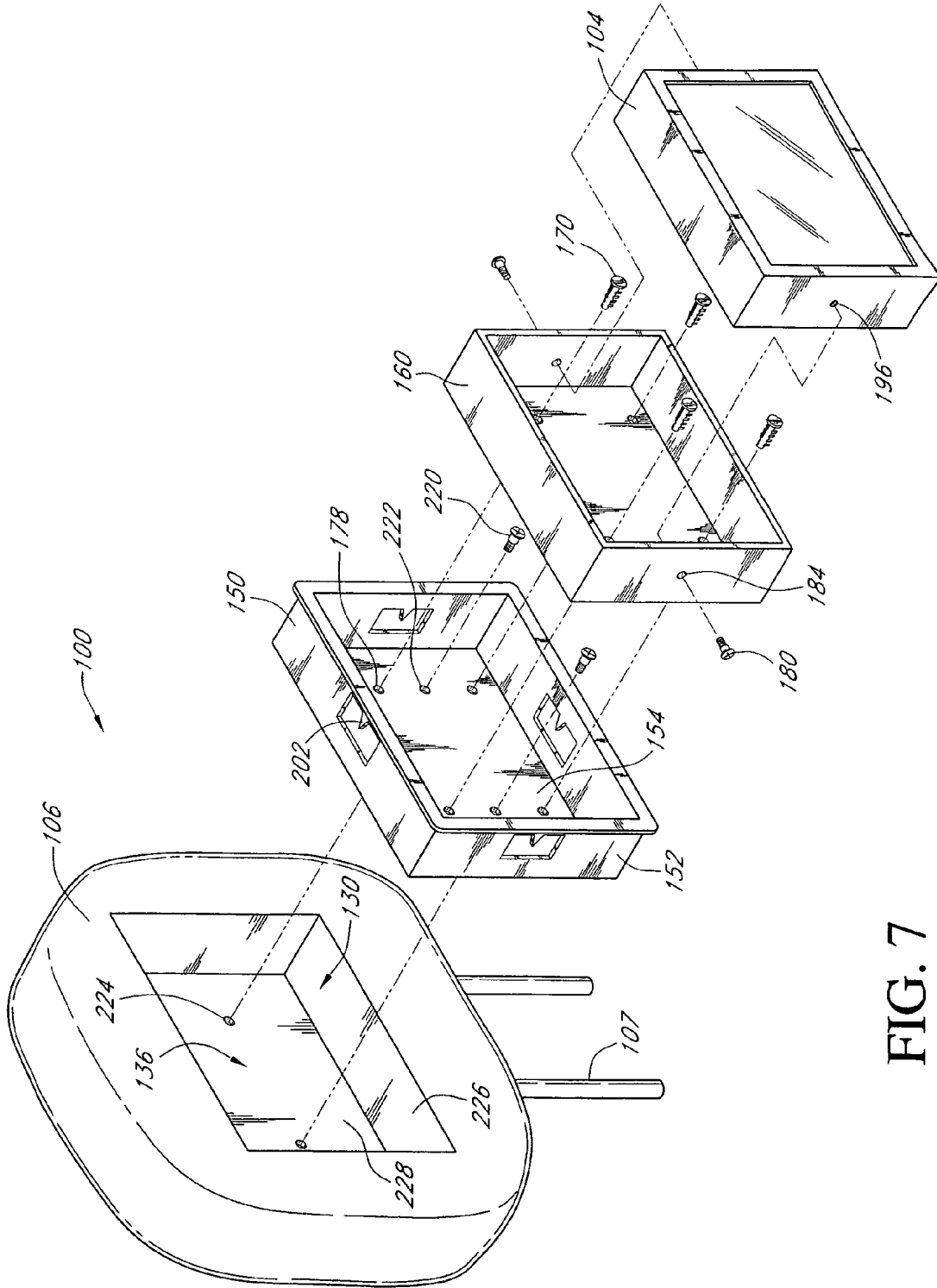

FIG. 7

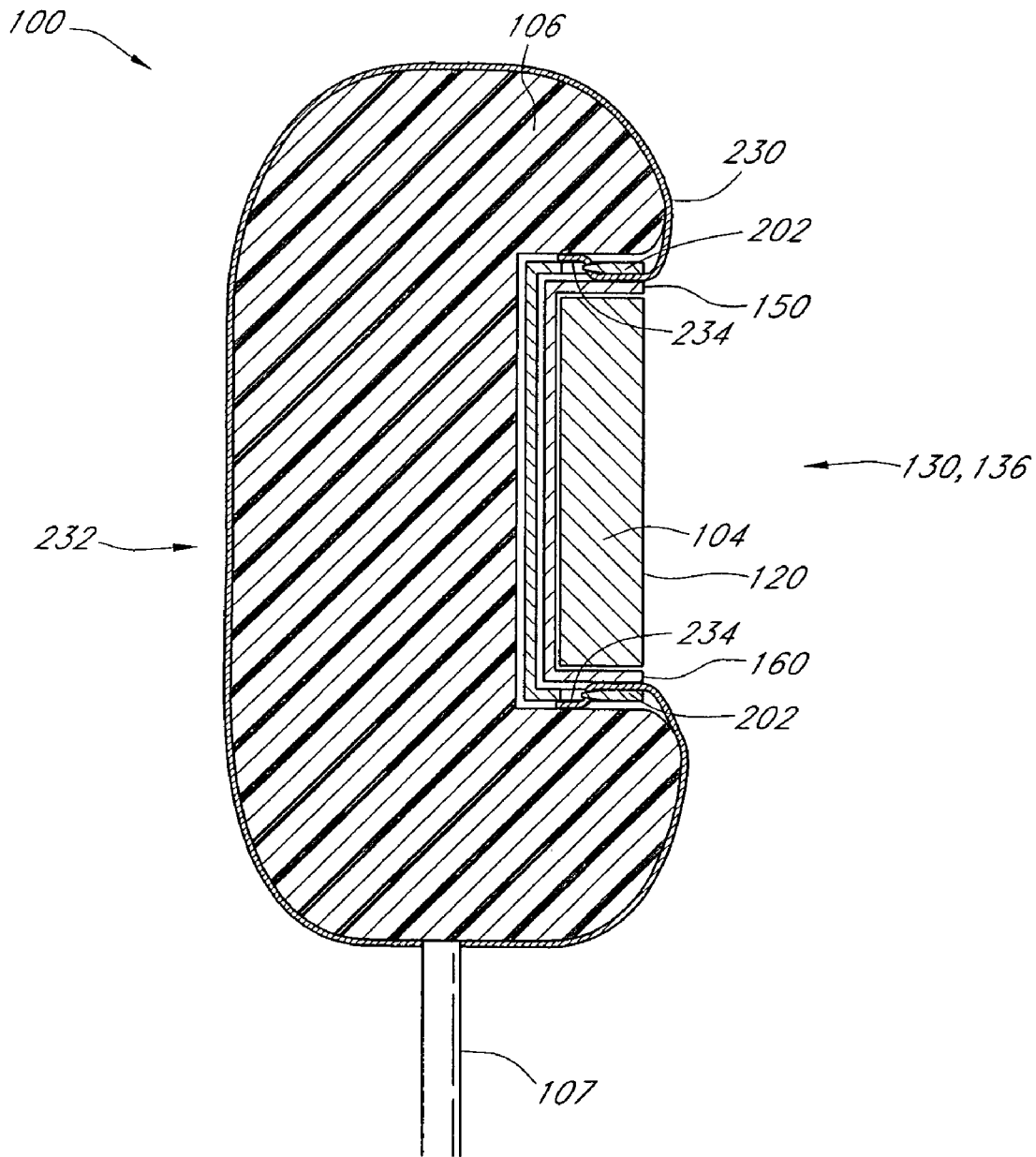

FIG. 8



US 7,407,227 B1

1

**HEADREST HAVING AN INTEGRATED  
VIDEO SCREEN**

## RELATED APPLICATIONS

This application is a continuation of U.S. application Ser. No. 10/395,870 filed Mar. 20, 2003 now U.S. Pat. No. 7,040,697, entitled "HEADREST HAVING AN INTEGRATED VIDEO SCREEN," which is hereby incorporated by reference herein in its entirety; and this application is related to U.S. application Ser. No. 10/819,341 filed Apr. 5, 2004, entitled "HEADREST/HEAD RESTRAINT HAVING AN INTEGRATED VIDEO SCREEN," and to U.S. application Ser. No. 11/415,918 filed concurrently with this application, entitled "HEADREST HAVING AN INTEGRATED VIDEO SCREEN," which is a divisional of the above-identified Ser. No. 10/395,870 application.

## BACKGROUND OF THE INVENTION

## 1. Field of the Invention

The present invention relates to motor vehicles and, in particular, to a headrest for motor vehicle seats having an integrated video screen mounted therein.

## 2. Description of the Related Art

Seat back video monitors are becoming increasingly popular in vehicles. Originally, these entertainment systems were largely confined to airplanes, however, recently, these systems have become much more popular with cars, trucks and SUVs. These entertainment systems provide the opportunity for passengers to view entertainment or educational video programs during long trips.

Typically, these systems have been installed as aftermarket products where the seat back is modified to accept the video display device, however, more of these systems are being installed as original equipment. Unfortunately, existing systems are often difficult and labor intensive to mount, particularly as an aftermarket product and are also subject to being dislodged.

Generally, the devices are mounted on the outer surface of the seat back where they protrude. In many vehicles, the space between seats and seat backs is limited, hence the protruding video display unit can inhibit the ability of passengers to easily get into and out of the vehicles. Moreover, passenger contact with the protruding video display screen may result in the screens being inadvertently dislodged.

A further difficulty with many existing video display unit designs is that they are not well secured to the seat. This is particularly the case for designs that allow the video display unit to pivot about an axis to improve the viewing angle of the passenger. One common way that these display units are installed is that a bucket is installed into the seat and the peripheral rim of the bucket includes openings that receive pivot posts that extend outward from the housing of the display unit. The pivot posts are positioned within the openings and keepers or caps are then positioned in the openings to prevent the pivot posts from being removed from the openings.

In these designs, the keepers or caps are generally press fit and are exposed to the passenger. Hence, inadvertent contact may result in the keepers or caps being dislodged. Moreover, many of the passengers are children who, through boredom, may attempt to remove the keepers which can result in the video display being dislodged and potentially damaged.

Hence, from the foregoing, there is a need for a seat back video display system and method of mounting that provides more secure mounting of the video display unit. To this end,

2

there is a need for an assembly that is less likely to be dislodged through inadvertent contact and does not have exposed detachable mounting components.

## SUMMARY OF THE INVENTION

The aforementioned needs may be satisfied by a seat back video display assembly adapted to be positioned in the back of a vehicle seat having an outer skin cover. In one aspect, the assembly may comprise a receptacle member having sidewalls and a back wall so as to define an opening, wherein the receptacle member is adapted to be positioned in the back of the vehicle seat. In addition the assembly may further comprise a carrier member having sidewalls and a back wall so as to define an opening, wherein the carrier member includes at least one fastener that extends from the back wall of the carrier member and engages with the back wall of the receptacle member to secure the carrier member into the receptacle member, and a video display unit that is sized so as to be positioned secured within the opening in the carrier member, wherein the video display unit provides video signals.

Additionally, in one embodiment, the at least one fastener may comprise a plurality of fasteners that include a central member that extends outward from back wall of the carrier member and a plurality of flexible engagement members attached to the central member, wherein the flexible engagement members are deformable so as to allow insertion of the central member into the openings in the back wall of the receptacle member, and wherein the flexible engagement members are biased outward so as to inhibit removal of the central member from the openings in the back wall of the receptacle member. Also, the video display unit may be pivotally attached to the carrier member such that the plane of the video display unit can be adjusted by a user about a pivot point or axis, wherein the video display unit may be pivotable about a substantially horizontal pivot axis, a substantially vertical pivot axis, or pivot point that allows a continuous range of pivotal motion about the pivot point. Also, the openings may be positioned in the sidewalls of the receptacle member and the plurality of capture members are positioned within the openings, and wherein the plurality of capture members define a pointed surface that engages with the outer skin and inhibits removal of the outer skin from the opening defined by the receptacle member so as to securely fasten the outer skin to the receptacle member.

Additionally, in certain embodiments, the seat back video display assembly includes a screen cover that is dimensioned to cover the video display unit such that the screen cover can disengageably cover the screen of the video display unit to occlude the screen. The screen cover can include an impact attenuating material, a rigid protective layer, or any combination thereof.

The aforementioned needs may also be satisfied by a vehicle seat assembly having a seat back display. In one aspect, the vehicle seat assembly may comprise a vehicle seat adapted to receive an occupant during travel of a vehicle, the vehicle seat defining a seat back with an outer contour and a skin, and a receptacle member having sidewalls and a back wall to as to define an opening, wherein the receptacle member is mounted in the seat back of the vehicle seat such that the sidewalls are located at or below the outer contour of the seat back. In addition, the vehicle seat assembly may further comprise a video display unit mounted within the receptacle member, wherein the video display unit is generally planar with the outer plane being mounted at or below the outer contour of the seat back.

US 7,407,227 B1

3

Moreover, the aforementioned needs may also be satisfied by a method of installing a video display unit into a seat back of a vehicle seat. In one embodiment, the method may comprise cutting an opening through an outer skin of the seat back, forming an aperture in the seat back, and positioning a receptacle in the aperture such that the receptacle is mounted at or below the level of the seat back. In addition, the method may comprise securing the video display unit to a carrier, and mounting the carrier into the receptacle such that an upper surface of the video display unit is mounted below the outer surface of the seat back. These and other objects and advantages of the present invention will become more fully apparent from the following description taken in conjunction with the accompanying drawings.

#### BRIEF DESCRIPTION OF THE DRAWINGS

FIG. 1A illustrates an adjustable headrest for a motor vehicle seat having an integrated video screen mounted therein.

FIG. 1B illustrates a fixed headrest for a motor vehicle seat having the integrated video screen of FIG. 1A mounted therein.

FIG. 2 illustrates a side view of the adjustable headrest shown in FIG. 1A having the integrated video screen mounted therein with a recessed orientation.

FIGS. 3A, 3B illustrate a cross-sectional view of the adjustable headrest shown in FIG. 1A having the integrated video screen mounted therein with a screen cover.

FIG. 4 illustrates a cross-sectional view of the integrated video screen being mounted to the headrest via a carrier receptacle, a carrier member, and a plurality of fasteners.

FIG. 5 illustrates a perspective view of the integrated video screen being mounted to the headrest via the carrier member and the plurality of fasteners of FIG. 4.

FIGS. 6A, 6B illustrate a perspective view of mounting the integrated video screen to the carrier member.

FIG. 6C illustrates a side view of mounting the integrated video screen to the carrier member via pivot member.

FIG. 7 illustrates a perspective view of mounting the integrated video screen to the adjustable headrest of FIG. 1A.

FIG. 8 illustrates a cross-sectional view of the video screen mounted to the headrest, wherein an outer skin from the headrest is secured to the carrier receptacle.

#### DETAILED DESCRIPTION OF THE PREFERRED EMBODIMENT

Reference will now be made to the drawings wherein like numerals refer to like parts throughout. A headrest for motor vehicle seats having an integrated video screen mounted therein in a flush or recessed manner will be described in greater detail herein below with reference to the drawings. In one aspect, it should be appreciated that the term motor vehicle seats refers to a plurality of generally known motor vehicles seats, such as those manufactured for automobiles, buses, boats, cars, semi-trucks, etc., wherein the following discussion can be similarly applied to these various types of motor vehicle seats without departing from scope of the present teachings. In addition, the following discussion refers to mounting the integrated video screen to the headrest of motor vehicle seats but may also be applied to other various component features of motor vehicle seats, such as the seat back, without departing from the scope of the present teachings.

FIG. 1A illustrates an adjustable headrest 100 for a first motor vehicle seat 102 having an integrated video screen 104

4

mounted therein. As illustrated in FIG. 1A, the adjustable headrest 100 is coupled to the seat 102 via posts 107 that extend therefrom and allow vertical adjustment of the adjustable headrest 100 with respect to the seat 102 in a generally known manner. FIG. 1B illustrates a fixed headrest 110 for a second motor vehicle seat 112 having the integrated video screen 104 mounted therein. In one embodiment, the video screen 104 is mounted within a headrest bun 106, 116 that is adapted to receive the video screen 104 for firm attachment therein in a manner that will be described in greater detail herein below. In addition, as will be described in greater detail herein below, the video screen 102 is mounted such that a front surface 120 of the video screen 104 is either flush or recessed from a contour 122 of the headrest 100, 110.

In one embodiment, the video screen 104 comprises a generally known LCD (liquid crystal display) monitor or terminal that can be electrically coupled to a video entertainment system so as to receive video signals therefrom for viewing of movies, television, internet web pages, video games, etc. As illustrated, the video screen 104 is generally rectangular in shape with the planar front surface 120 that is viewable by a user. In one aspect, it should be appreciated that the degree of recessed depth (with no depth comprising a flush mount) of the integrated video screen 104 and the manner in which the contour 122 of the seat 102, 112 is shaped may be selected such that the shape (side view, for example) of the headrest 100, 110 with the integrated video screen 104 mounted therein is generally similar to the shape of the headrest 100, 110 without the integrated video screen 104. Moreover, it should be appreciated that the motor vehicle seats 102, 112 may comprise any one of a number of various types or models of generally known motor vehicle seats without departing from the scope of the present invention.

FIG. 2 illustrates a side view of the adjustable headrest 100 shown in FIG. 1A having the integrated video screen 104 mounted therein with a recessed orientation. It should be appreciated that the following discussion is with respect to the adjustable headrest 100 of FIG. 1A but may be similarly applied to the fixed headrest 110 of FIG. 1B without departing from the scope of the present teachings.

FIG. 2 further illustrates the side view shape or contour 122 of the headrest 100. As illustrated in FIG. 2, the contour 122 of the headrest 100 is maintained due to the recessed orientation of the video screen 104 within the headrest bun 106. In addition, an opening 130 is formed in a rear section 132 of the headrest 100 so as to define a substantially rectangular interior region 136 within the headrest bun 106 below an outer surface 134 of the headrest 100. As further illustrated in FIG. 2, the video screen 104 can then be positioned adjacent the opening 130 so as to be firmly positioned within the interior region 136 of the headrest bun 106. Moreover, the recessed orientation may be defined by a depth 138 between the front surface 120 of the video screen 104 and the outer surface 134 of the headrest 100. The depth 138 therebetween may vary in magnitude depending on the thickness of the headrest bun 106 and/or the internal structural characteristics of the headrest 100, which may vary with respect to the type or model of motor vehicle seat used. In one aspect, the depth 138 of the recessed orientation may comprise a magnitude of approximately zero so as to define a flush mounted video screen 104, wherein the front surface 1120 of the video screen 104 is substantially aligned with the outer surface 134 of the headrest 100.

FIG. 3A illustrates a cross-sectional view of the adjustable headrest 102 shown in FIG. 1A having the integrated video screen 104 mounted therein with the recessed orientation shown in FIG. 2 and a screen cover 140. In one embodiment,

US 7,407,227 B1

5

the screen cover 140 is coupled to the rear section 132 of the headrest 100 via a hinge 142 so as to overlie the video screen 104 and at least part of the opening 130 formed therein. The screen cover 140 may comprise generally rectangular shape and is oriented generally parallel to the front surface 120 of the video screen 104 so as to temporarily occlude the video screen 104. In one aspect, as further illustrated in FIG. 3A, the screen cover 140 can be positioned adjacent the opening 130 so as to substantially align with the outer surface 134 of the headrest 100 thus forming a flush mounting therewith. It should be appreciated that the screen cover 140 may be positioned within the opening 130 so as to be recessed with respect to the outer surface 134 of the headrest 100 without departing from the scope of the present teachings. Moreover, the screen cover 140 may comprise a rigid material, such as plastic, metal, etc. Alternatively, in another aspect, the screen cover 140 may comprise a piece or flap of material from an outer skin 230 (FIG. 8) of the motor vehicle seat 102 that is attached to the headrest 100 adjacent the lower side of the video screen 104.

In still another aspect, as illustrated in FIG. 3B, the screen cover 140 may comprise an impact attenuating section 143 comprising a material such as foam, various types of padding, an air cushion, etc. so as to soften the force of an impact from an object. For example, during a car accident, a person's head may be propelled towards the screen cover 140, wherein the impact attenuating material may soften the impact to the headrest 102 to thereby protect the person's head and the video screen 104 from damage.

Also, in one embodiment, the video screen 104 can be viewed by opening the screen cover 140 or temporarily occluded by closing the screen cover 140. Hence, the screen cover 140 can be outwardly rotated about the hinge 142 in a first direction 144 to openly view the video screen 104, or the screen cover 140 can be inwardly rotated about the hinge 142 in a second direction 144 opposite the first direction 144 to temporarily occlude the video screen 104. Advantageously, the screen cover 104, when closed, conceals the video screen 104 from view thus, in some situations, functions as a thief deterrent.

Moreover, in one aspect, the recessed configuration of the video screen 104 facilitates the manner in which the screen cover 140 may be deployed. For example, the video screen 104 may not physically interfere with the closing of the screen cover 140. In addition, as illustrated in FIGS. 3A, 3B, the screen cover 140 is intended to "hide" the video screen 104 from outside observers, thereby reducing the probability that the video screen 104 will be a target of theft. As further illustrated in FIGS. 3A, 3B, the screen cover 140 may further comprise a means for engagement 147 that allows the screen cover 140 to remain in the "up" or closed configuration. In general, it should be appreciated that some possible means for achieving such an engagement include but are not limited to magnetic strips, mechanical clips, velcro strips, and the like.

FIG. 4 illustrates a cross-sectional view of the integrated video screen 104 being mounted to the headrest 100 via a carrier receptacle 150, a carrier member 160, and first fasteners 170. FIG. 5 illustrates a perspective view of the integrated video screen 104 being mounted to the headrest 100 via the carrier receptacle 150, the carrier member 152, and the first fasteners 170. In one embodiment, the carrier receptacle 150 comprises a plurality of planar sidewalls 152 and a rear planar wall 154 that are joined together in a manner so as to form a substantially rectangular outer structure 156 having an inner recessed region 158 that is adapted to receive the carrier member 152 therein. Similarly, the carrier member 152 comprises a plurality of planar sidewalls 162 and a rear planar wall

6

164 that are joined together in a manner so as to form a substantially rectangular outer structure 166 having an inner recessed region 168 that is adapted to receive the video screen 104 therein.

As illustrated in FIG. 4, the video screen 104 may be mounted within the carrier member 160 via side fasteners 180 (shown in FIGS. 6A, 6B) and then the carrier member 152 is mounted within the carrier receptacle 150 via the first fasteners 170 so as to simplify the mounting of the video screen 104 to the headrest 100 including the headrest bun 106. In one aspect, the first fasteners 170 may comprise a plurality of flexible engagement members 172 that extend therefrom so as to mechanically couple with a plurality of mounting apertures 174 (FIG. 5) formed in the rear wall 154 of the carrier receptacle 150. The first fasteners 170 may further comprise a central member 173 that extends outward from the rear wall 164 of the carrier member 160. Also, the flexible engagement members 172 are attached to the central member 173, wherein the flexible engagement members 172 are deformable so as to allow insertion of the central member 173 into the mounting apertures 174 in the rear wall 164 of the carrier receptacle 150. Moreover, the flexible engagement members 170 are biased outward so as to inhibit removal of the central member 173 from the mounting apertures 174 in the rear wall 154 of the carrier receptacle 150. In addition, the first fasteners 170 comprise a head 176 that abuts the rear wall 164 of the carrier member 152 and is positioned through a plurality of second apertures 178 formed in the rear wall 164 of the carrier member 152.

Advantageously, the video screen 104 can be mounted to the headrest 100 via the carrier receptacle 150 and the carrier member 152 without using external fasteners that may be seen. Hence, the video screen 104 can be mounted to the headrest 100 in a more aesthetically appealing manner, wherein the front surface 120 of the video screen 104 recessed or flush mounted with respect to the outer surface 134 of the headrest 100, and wherein the first and second fasteners 170, 180 are concealed from view.

As illustrated in FIG. 5, the sidewalls 152 of the carrier receptacle 150 each comprise at least one sidewall aperture 200 having at least one serrated tooth 202 protruding from an interior sidewall 204. In one embodiment, the at least one serrated tooth 202 is triangular in shape having a pointed tip 206 that projects outward from the interior sidewall 204 in a horizontal manner. It should be appreciated that the serrated tooth 202 may comprise any one of a number of various shapes known in the art without departing from the scope of the present teachings. Additionally, as will be shown in FIG. 8, the pointed tip 234 engages with the outer skin 230 (FIG. 8) and inhibits removal of the outer skin 230 from the at least one sidewall aperture 200 formed in the carrier receptacle 150. Advantageously, as will be described in greater detail herein below, the serrated tooth 200 allows outer skin from the motor vehicle seat 102, 112 to be attached to the carrier receptacle 150 by wrapping the outer skin around the planar sidewalls 152 and into the recessed region 158 of the carrier receptacle 150 and then securing the outer skin to the serrated tooth 200.

FIG. 6A illustrates a perspective view of attaching the integrated video screen 104 to the carrier member 152 via the second fasteners 180. In one embodiment, the planar sidewalls 162 of the carrier member 160 comprise pivot apertures 184 that allow the video display 104 to be mounted to the carrier member 160. Also, the pivot apertures 184 are adapted to rotatably receive the second fasteners 180. As illustrated in FIG. 6A, the second fasteners 180 comprise a threaded region 186 that mechanically couples to threaded apertures 196 (FIG. 7) formed in the video screen 104 in a generally known



US 7,407,227 B1

7

manner so as to be securely attached thereto. Moreover, the second fasteners **180** further comprise a head **182** and a smooth pivot region **188** interposed between the threaded region and the head **182**.

In one aspect, the pivot region **188** of the second fastener **180** rotatably communicates with the pivot aperture **184** of the carrier member **160** to thereby allow the video screen **104** to pivot or tilt with respect to the carrier member **160** and/or the headrest **100** along a horizontal pivot axis **190** defined by the horizontally mounted second fasteners **180**. Hence, the video screen **104** is pivotally attached to the carrier member **160** such that the plane of the video screen **104** can be adjusted with respect to the headrest **100** by a user about the defined horizontal pivot axis **190**. Advantageously, the horizontal pivot axis **190** allows the video screen **104** to readily pivot when mounted to the headrest **100** to thereby allow greater positional flexibility during viewing of the video screen **104** by a user.

FIG. 6B further illustrates a perspective view of attaching the integrated video screen **104** to the carrier member **152** via the second fasteners **180**. In one embodiment, as illustrated in FIG. 6B, the second fasteners **180** can be mounted vertically through the planar sidewalls **162** of the carrier member **160**. The pivot region **188** of the vertically mounted second fasteners **180** rotatably communicates with the pivot aperture **184** of the carrier member **160** to thereby allow the video screen **104** to pivot or tilt side-to-side with respect to the carrier member **160** and/or the headrest **100** along a vertical pivot axis **191** defined by the vertically mounted second fasteners **180**. Hence, the video screen **104** is pivotally attached to the carrier member **160** such that the plane of the video screen **104** can be adjusted with respect to the headrest **100** by a user about the vertical pivot axis **191**. Advantageously, the vertical pivot axis **191** allows the video screen **104** to readily pivot when mounted to the headrest **100** to thereby allow greater positional flexibility during viewing of the video screen **104** by a user.

In one aspect, it should be appreciated that the second fasteners **180** may comprise generally known screws, such as sheet metal screws, without departing from the scope of the present invention. It should also be appreciated that the pivot region **188** of the second fasteners **180** may be threaded in a manner such that the video screen **104** can still pivot with respect to the carrier member **150** without departing from the scope of the present invention.

FIG. 6C illustrates a view of attaching the integrated video screen **104** to the carrier member **152** via a pivot member **240**. In one embodiment, as illustrated in FIG. 6C, the pivot member **240** comprises a spherical ball **242** attached to the video screen **104** via a shaft **244** and a plate **246**. The spherical ball **242** is positioned within a spherical receptacle **248** formed in the rear wall **164** of the carrier member **160**. As illustrated in FIG. 6C, the rear wall **164** of the carrier member **160** may be dimensioned so as to accommodate the spherical receptacle **248**. In one aspect, the plate **246** of the pivot member **240** may be attached to the video screen **104** using an adhesive, such as epoxy or glue, or fasteners, such as screws or bolts. In addition, the shaft **244** distally extends from the plate **246** towards the spherical receptacle **248** of the carrier member **160**. Also, the shaft **244** and the spherical ball **242** may be formed as an integral part of the plate **246** or may be formed separately and interconnected to the plate **246** via an adhesive or fasteners.

Moreover, once the pivot member **240** is attached to the video screen **104** in a manner as previously described, the spherical ball **242** of the pivot member **240** can be pressed to fit within the spherical receptacle **248** formed in the rear wall **164** of the carrier member **160**. In one aspect, the spherical ball **242** may be sized at least less than the size of the spherical receptacle **248** so as to allow rotational movement therein. Advantageously, the resulting interconnection between the

8

spherical ball **242** of the pivot member **240** and the spherical receptacle **248** of the carrier member **160** defines a pivot point **250** to thereby allow the video screen **104** to pivot, tilt, or rotate in a multi-directional manner with respect to the defined pivot point **250**. Therefore, the defined pivot point **250** allows the video screen **104** to readily pivot when mounted to the headrest **100** to thereby allow greater positional flexibility during viewing of the video screen **104** by a user.

FIG. 7 illustrates a perspective view of mounting the integrated video screen **104** to the headrest **100** of FIG. 1A. In one embodiment, as illustrated in FIG. 7, the opening **130** is formed in the headrest bun **106** so as to define the substantially rectangular interior region **136** and to receive the carrier receptacle **150**. The carrier receptacle **150** can then be positioned within the opening **130** so that the planar sidewalls **152** and the planar rear wall **154** abut the interior walls **226** of the mounting recess **136** formed in the headrest bun **106**. In one embodiment, the carrier receptacle **150** can be secured to the headrest **100** via one or more third fasteners **220**, such as screws, machine screws, sheet metal screws, etc. As illustrated in FIG. 7, the third fasteners **220** are positioned through rear wall apertures **222** formed in the rear wall **154** of the carrier receptacle **150** and coupled to rear mounting apertures **224** formed in a back wall **226** of the mounting recess **136** of the headrest bun **106**. Advantageously, the third fasteners **220** can be securely attached to a structural component (not shown) of the headrest **100**, such as an internal framework member of the headrest **100**, so as to form a rigid attachment between the carrier receptacle **150** and the headrest **100**.

In addition, the video screen **104** may be mounted to the carrier member **160** so as to pivot with respect thereto in a manner as previously described with reference to FIGS. 6A, 6B, 6C. Following, the carrier member **160** including the video screen **104** can then be mounted to the carrier receptacle **150** via the first fasteners **170** in a manner as previously described with reference to FIG. 4. Advantageously, this method of attaching the video screen **104** to the headrest **100** via the carrier receptacle **150**, the carrier member **160**, and the fasteners **170**, **180** allows the video screen **104** to be securely mounted to the headrest **100** while providing a means for pivoting the video screen **104** with respect to the headrest **100** so as to improve the viewing range by a user.

FIG. 8 illustrates a cross-sectional view of the video screen **104** mounted to the headrest **100**, wherein the outer skin **230** of the headrest **100** of the motor vehicle seat **102** is attached to the carrier receptacle **150** and the carrier member **160** with the video screen **104** mounted therein is mounted within the mounting recess **136** of the carrier receptacle **150**. As is generally known, many motor vehicle car seats comprise the illustrated outer skin **230**, such as fabric, leather, upholstery, vinyl, etc., that provides a outer surface **232** for a user to lean against or rest upon. In one aspect, when mounting the integrated video screen **104** into the headrest **100** of the motor vehicle seat **102**, the outer skin **230** is adapted to accommodate the video screen **104** including the carrier receptacle **150**. In some situations, one or more flaps **234** can be formed in the outer skin **230** and attached to the one or more serrated teeth **202** formed in the planar sidewalls **152** of the carrier receptacle **150**.

As further illustrated in FIG. 8, the carrier receptacle **150** may be positioned within the mounting recess **136** formed in the headrest bun **106**, and then the outer skin **230** is secured to the serrated teeth **202** via the flaps **234** formed therein by hooking the flaps **234** to one or more of the serrated teeth **202**. Once the outer skin **230** is attached to the serrated teeth **202** via the flaps **234**, the carrier member **160** is firmly pressed within the mounting recess **136** of the headrest bun **106** so that the first fasteners **170** couple to the mounting apertures **174** formed in the rear wall **154** of the carrier receptacle **150**.

Advantageously, this interconnection between the carrier member 160 and carrier receptacle 150 provides a quick and easy means for mounting of the video screen 104 to the headrest 100. In addition, the pressed fit of the outer skin between the carrier member 160 and the carrier receptacle 150 further secures the outer skin of the motor vehicle seat 102 to the carrier receptacle 150. As a result, the outer skin is securely held to the carrier receptacle 150 via the one or more serrated teeth 202 formed in the planar sidewalls 152 of the carrier receptacle 150 and the pressed fit of the carrier member 160 within the mourning recess 136 of the carrier receptacle 150.

Although the foregoing description has shown, described and pointed out the fundamental novel features of the invention, it will be understood that various omissions, substitutions, and changes in the form of the detail of the apparatus as illustrated, as well as the uses thereof, may be made by those skilled in the art, without departing from the spirit or scope of the present invention. Consequently, the scope of the invention should not be limited to the foregoing discussion, but should be defined by the appended claims.

What is claimed is:

1. A headrest assembly for a vehicle seat, the assembly comprising:

a receptacle member having a plurality of sidewalls and a back wall so as to define an opening wherein the receptacle member is adapted to be positioned in a back of the vehicle seat wherein the opening is facing away from the back of the vehicle seat when the receptacle member is positioned within the back of the vehicle seat and wherein the back wall of the receptacle member defines at least one securing aperture;

a carrier member having a plurality of sidewalls and a back wall so as to define an opening, wherein the opening in the carrier member is facing away from the back of the vehicle seat when the carrier member is positioned within the receptacle member and wherein the back wall of the carrier member defines at least one securing aperture;

an outer skin having edges that extend into the opening of the receptacle member and attached to at least some of the plurality of sidewalls of the receptacle member and wherein the edges of the outer skin are substantially concealed when the carrier member is positioned within the opening of the receptacle member;

at least one fastener that extends through the at least one securing aperture of the carrier member and engages with the at least one securing aperture of the receptacle member to allow securing of the carrier member in the opening of the receptacle member;

a video display unit that is sized so as to be positioned within the opening in the carrier member and substantially conceal the at least one fastener when in a viewing orientation.

2. The assembly of claim 1, wherein the at least one fastener comprises a plurality of fasteners that include a central member dimensioned to extend through the securing aperture of the carrier member and a plurality of flexible engagement members attached to the central member, wherein the flexible engagement members are deformable so as to allow insertion of the central member into the corresponding securing aperture of the receptacle member, and wherein the flexible engagement members are biased outward so as to inhibit removal of the central member from the apertures of the receptacle member.

3. The assembly of claim 1, wherein the video display unit defines a plane and is pivotally attached to the carrier member such that the plane of the video display unit can be adjusted by a user about a pivot axis.

4. The assembly of claim 3, wherein the video display unit is pivotable about a substantially horizontal axis.

5. The assembly of claim 3, wherein first and second pivot member coupled to the video display unit are positioned through the carrier member so as to define the pivot axis and pivotably secure the video display unit to the carrier member.

6. The assembly of claim 1, wherein the receptacle member includes an outer lip and a plurality of outer skin capture members that engage with the outer skin such that the outer skin is extended over the outer lip of the receptacle member and secured to the outer skin capture members.

7. The assembly of claim 6, wherein the plurality of capture members define a pointed surface that engages with the outer skin and inhibits removal of the outer skin from the opening defined by the receptacle member.

8. The assembly of claim 1, further comprising a screen cover that is dimensioned to cover the video display unit, and wherein the cover is selectively disengagable so as to allow visual access to the video display unit.

9. The assembly of claim 8, wherein the cover includes an impact attenuating material.

10. The assembly of claim 8, wherein the cover includes a generally rigid layer to provide physical protection of the video display unit.

11. The assembly of claim 1, wherein the receptacle member has four sidewalls.

12. The assembly of claim 1, wherein the carrier member has four sidewalls.

13. The assembly of claim 1, wherein the edges of the outer skin are secured to each of the plurality of sidewalls.

14. A headrest assembly for a vehicle seat, the assembly comprising:

a receptacle member having a plurality of sidewalls that are joined to a back wall so as to define an opening wherein the receptacle member is adapted to be positioned in a back of the vehicle seat wherein the opening is facing away from the back of the vehicle seat when the receptacle member is positioned within the back of the vehicle seat and wherein the back wall of the receptacle member defines at least one securing aperture;

a carrier member having a plurality of sidewalls and a back wall so as to define an opening, wherein the opening in the carrier member is facing away from the back of the vehicle seat when the carrier member is positioned within the receptacle member and wherein the back wall of the carrier member defines at least one securing aperture;

an outer skin having edges that extend into the opening of the receptacle member and secured to at least some of the plurality of sidewalls of the receptacle member, and wherein the edges of the outer skin are substantially concealed when the carrier member is positioned within the opening of the receptacle member;

at least one fastener that extends through the at least one securing aperture of the carrier member and engages with the at least one securing aperture of the receptacle member to allow securing of the carrier member in the opening of the receptacle member;

a video display unit that is sized so as to be positioned within the opening in the carrier member and substantially conceal the at least one fastener when in a viewing orientation.



**UNITED STATES DISTRICT COURT  
CENTRAL DISTRICT OF CALIFORNIA**

**NOTICE OF ASSIGNMENT TO UNITED STATES MAGISTRATE JUDGE FOR DISCOVERY**

This case has been assigned to District Judge Stephen G. Larson and the assigned discovery Magistrate Judge is Oswald Parada.

The case number on all documents filed with the Court should read as follows:

**EDCV09- 1300 SGL (OPx)**

Pursuant to General Order 05-07 of the United States District Court for the Central District of California, the Magistrate Judge has been designated to hear discovery related motions.

All discovery related motions should be noticed on the calendar of the Magistrate Judge

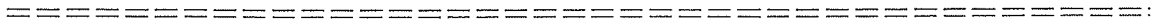

**NOTICE TO COUNSEL**

*A copy of this notice must be served with the summons and complaint on all defendants (if a removal action is filed, a copy of this notice must be served on all plaintiffs).*

Subsequent documents must be filed at the following location:

**Western Division**  
312 N. Spring St., Rm. G-8  
Los Angeles, CA 90012

**Southern Division**  
411 West Fourth St., Rm. 1-053  
Santa Ana, CA 92701-4516

**Eastern Division**  
3470 Twelfth St., Rm. 134  
Riverside, CA 92501

Failure to file at the proper location will result in your documents being returned to you.

ORIGINAL

UNITED STATES DISTRICT COURT  
CENTRAL DISTRICT OF CALIFORNIA

TMI PRODUCTS, INC.

CASE NUMBER

PLAINTIFF(S)

ED CV 09 - 01300 SGL(OPX)

v.

ROSEN ENTERTAINMENT SYSTEMS, L.P.

SUMMONS

DEFENDANT(S).

TO: DEFENDANT(S): ROSEN ENTERTAINMENT SYSTEMS, L.P.

A lawsuit has been filed against you.

Within 20 days after service of this summons on you (not counting the day you received it), you must serve on the plaintiff an answer to the attached  complaint  \_\_\_\_\_ amended complaint  counterclaim  cross-claim or a motion under Rule 12 of the Federal Rules of Civil Procedure. The answer or motion must be served on the plaintiff's attorney, Reynaldo C. Barcelo, whose address is Barcelo & Harrison, LLP, 2901 West Coast Hwy, Suite 200, Newport Beach, CA 92663. If you fail to do so, judgment by default will be entered against you for the relief demanded in the complaint. You also must file your answer or motion with the court.

**TERRY NAFISI**

Clerk, U.S. District Court

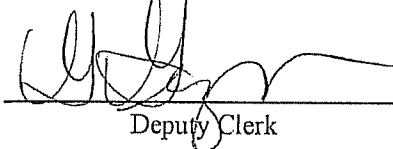
By:   
Deputy Clerk

**JUL - 9 2009**

Dated: \_\_\_\_\_

(Seal of the Court)

[Use 60 days if the defendant is the United States or a United States agency, or is an officer or employee of the United States. Allowed 60 days by Rule 12(a)(3)].

UNITED STATES DISTRICT COURT - CENTRAL DISTRICT OF CALIFORNIA

CIVIL COVER SHEET

<p><b>I (a) PLAINTIFFS</b> (Check box if you are representing yourself <input type="checkbox"/>)</p> <p style="text-align: center;">TMI PRODUCTS, INC.</p>	<p><b>DEFENDANTS</b></p> <p style="text-align: center;">ROSEN ENTERTAINMENT SYSTEMS, L.P.</p>
<p><b>(b) Attorneys</b> (Firm Name, Address and Telephone Number. If you are representing yourself, provide same.)</p> <p style="text-align: center;">REYNALDO C. BARCELO (199741), BARCELO &amp; HARRISON, LLP 2901 West Coast Hwy, Suite 200 Newport Beach, CA 92663 (949) 340-9736</p>	<p><b>Attorneys (If Known)</b></p> <p style="text-align: center;">not yet known</p>

<p><b>II. BASIS OF JURISDICTION</b> (Place an X in one box only.)</p> <p><input type="checkbox"/> 1 U.S. Government Plaintiff     <input checked="" type="checkbox"/> 3 Federal Question (U.S. Government Not a Party)</p> <p><input type="checkbox"/> 2 U.S. Government Defendant     <input type="checkbox"/> 4 Diversity (Indicate Citizenship of Parties in Item III)</p>	<p><b>III. CITIZENSHIP OF PRINCIPAL PARTIES - For Diversity Cases Only</b> (Place an X in one box for plaintiff and one for defendant.)</p> <table style="width:100%; border: none;"> <tr> <td style="border: none;">Citizen of This State</td> <td style="border: none; text-align: center;"> <table style="font-size: small;"> <tr><td>P/JF</td><td>DEF</td></tr> <tr><td><input checked="" type="checkbox"/> 1</td><td><input checked="" type="checkbox"/> 1</td></tr> </table> </td> <td style="border: none;">Incorporated or Principal Place of Business in this State</td> <td style="border: none; text-align: center;"> <table style="font-size: small;"> <tr><td>P/JF</td><td>DEF</td></tr> <tr><td><input checked="" type="checkbox"/> 4</td><td><input checked="" type="checkbox"/> 4</td></tr> </table> </td> </tr> <tr> <td style="border: none;">Citizen of Another State</td> <td style="border: none; text-align: center;"> <table style="font-size: small;"> <tr><td><input type="checkbox"/> 2</td><td><input type="checkbox"/> 2</td></tr> </table> </td> <td style="border: none;">Incorporated and Principal Place of Business in Another State</td> <td style="border: none; text-align: center;"> <table style="font-size: small;"> <tr><td><input type="checkbox"/> 5</td><td><input type="checkbox"/> 5</td></tr> </table> </td> </tr> <tr> <td style="border: none;">Citizen or Subject of a Foreign Country</td> <td style="border: none; text-align: center;"> <table style="font-size: small;"> <tr><td><input type="checkbox"/> 3</td><td><input type="checkbox"/> 3</td></tr> </table> </td> <td style="border: none;">Foreign Nation</td> <td style="border: none; text-align: center;"> <table style="font-size: small;"> <tr><td><input type="checkbox"/> 6</td><td><input type="checkbox"/> 6</td></tr> </table> </td> </tr> </table>	Citizen of This State	<table style="font-size: small;"> <tr><td>P/JF</td><td>DEF</td></tr> <tr><td><input checked="" type="checkbox"/> 1</td><td><input checked="" type="checkbox"/> 1</td></tr> </table>	P/JF	DEF	<input checked="" type="checkbox"/> 1	<input checked="" type="checkbox"/> 1	Incorporated or Principal Place of Business in this State	<table style="font-size: small;"> <tr><td>P/JF</td><td>DEF</td></tr> <tr><td><input checked="" type="checkbox"/> 4</td><td><input checked="" type="checkbox"/> 4</td></tr> </table>	P/JF	DEF	<input checked="" type="checkbox"/> 4	<input checked="" type="checkbox"/> 4	Citizen of Another State	<table style="font-size: small;"> <tr><td><input type="checkbox"/> 2</td><td><input type="checkbox"/> 2</td></tr> </table>	<input type="checkbox"/> 2	<input type="checkbox"/> 2	Incorporated and Principal Place of Business in Another State	<table style="font-size: small;"> <tr><td><input type="checkbox"/> 5</td><td><input type="checkbox"/> 5</td></tr> </table>	<input type="checkbox"/> 5	<input type="checkbox"/> 5	Citizen or Subject of a Foreign Country	<table style="font-size: small;"> <tr><td><input type="checkbox"/> 3</td><td><input type="checkbox"/> 3</td></tr> </table>	<input type="checkbox"/> 3	<input type="checkbox"/> 3	Foreign Nation	<table style="font-size: small;"> <tr><td><input type="checkbox"/> 6</td><td><input type="checkbox"/> 6</td></tr> </table>	<input type="checkbox"/> 6	<input type="checkbox"/> 6
Citizen of This State	<table style="font-size: small;"> <tr><td>P/JF</td><td>DEF</td></tr> <tr><td><input checked="" type="checkbox"/> 1</td><td><input checked="" type="checkbox"/> 1</td></tr> </table>	P/JF	DEF	<input checked="" type="checkbox"/> 1	<input checked="" type="checkbox"/> 1	Incorporated or Principal Place of Business in this State	<table style="font-size: small;"> <tr><td>P/JF</td><td>DEF</td></tr> <tr><td><input checked="" type="checkbox"/> 4</td><td><input checked="" type="checkbox"/> 4</td></tr> </table>	P/JF	DEF	<input checked="" type="checkbox"/> 4	<input checked="" type="checkbox"/> 4																		
P/JF	DEF																												
<input checked="" type="checkbox"/> 1	<input checked="" type="checkbox"/> 1																												
P/JF	DEF																												
<input checked="" type="checkbox"/> 4	<input checked="" type="checkbox"/> 4																												
Citizen of Another State	<table style="font-size: small;"> <tr><td><input type="checkbox"/> 2</td><td><input type="checkbox"/> 2</td></tr> </table>	<input type="checkbox"/> 2	<input type="checkbox"/> 2	Incorporated and Principal Place of Business in Another State	<table style="font-size: small;"> <tr><td><input type="checkbox"/> 5</td><td><input type="checkbox"/> 5</td></tr> </table>	<input type="checkbox"/> 5	<input type="checkbox"/> 5																						
<input type="checkbox"/> 2	<input type="checkbox"/> 2																												
<input type="checkbox"/> 5	<input type="checkbox"/> 5																												
Citizen or Subject of a Foreign Country	<table style="font-size: small;"> <tr><td><input type="checkbox"/> 3</td><td><input type="checkbox"/> 3</td></tr> </table>	<input type="checkbox"/> 3	<input type="checkbox"/> 3	Foreign Nation	<table style="font-size: small;"> <tr><td><input type="checkbox"/> 6</td><td><input type="checkbox"/> 6</td></tr> </table>	<input type="checkbox"/> 6	<input type="checkbox"/> 6																						
<input type="checkbox"/> 3	<input type="checkbox"/> 3																												
<input type="checkbox"/> 6	<input type="checkbox"/> 6																												

**IV. ORIGIN** (Place an X in one box only.)

1 Original Proceeding      2 Removed from State Court      3 Remanded from Appellate Court      4 Reinstated or Reopened      5 Transferred from another district (specify):      6 Multi-District Litigation      7 Appeal to District Judge from Magistrate Judge

**V. REQUESTED IN COMPLAINT:** JURY DEMAND:  Yes      No (Check 'Yes' only if demanded in complaint.)

**CLASS ACTION** under F.R.C.P. 23:  Yes      No     **MONEY DEMANDED IN COMPLAINT:** \$ To be determined at trial

**VI. CAUSE OF ACTION** (Cite the U.S. Civil Statute under which you are filing and write a brief statement of cause. Do not cite jurisdictional statutes unless diversity.)

Patent infringement, 35 U.S.C. sec. 1 et seq.

**VII. NATURE OF SUIT** (Place an X in one box only.)

<p><b>OTHER STATUTES</b></p> <p><input type="checkbox"/> 400 State Reapportionment</p> <p><input type="checkbox"/> 410 Antitrust</p> <p><input type="checkbox"/> 430 Banks and Banking</p> <p><input type="checkbox"/> 450 Commerce/ICC Rates/etc.</p> <p><input type="checkbox"/> 460 Deportation</p> <p><input type="checkbox"/> 470 Racketeer Influenced and Corrupt Organizations</p> <p><input type="checkbox"/> 480 Consumer Credit</p> <p><input type="checkbox"/> 490 Cable/Sat TV</p> <p><input type="checkbox"/> 810 Selective Service</p> <p><input type="checkbox"/> 850 Securities/Commodities/Exchange</p> <p><input type="checkbox"/> 875 Customer Challenge 12 USC 3410</p> <p><input type="checkbox"/> 890 Other Statutory Actions</p> <p><input type="checkbox"/> 891 Agricultural Act</p> <p><input type="checkbox"/> 892 Economic Stabilization Act</p> <p><input type="checkbox"/> 893 Environmental Matters</p> <p><input type="checkbox"/> 894 Energy Allocation Act</p> <p><input type="checkbox"/> 895 Freedom of Info. Act</p> <p><input type="checkbox"/> 900 Appeal of Fee Determination Under Equal Access to Justice</p> <p><input type="checkbox"/> 950 Constitutionality of State Statutes</p>	<p><b>CONTRACT</b></p> <p><input type="checkbox"/> 110 Insurance</p> <p><input type="checkbox"/> 120 Marine</p> <p><input type="checkbox"/> 130 Miller Act</p> <p><input type="checkbox"/> 140 Negotiable Instrument</p> <p><input type="checkbox"/> 150 Recovery of Overpayment &amp; Enforcement of Judgment</p> <p><input type="checkbox"/> 151 Medicare Act</p> <p><input type="checkbox"/> 152 Recovery of Defaulted Student Loan (Excl. Veterans)</p> <p><input type="checkbox"/> 153 Recovery of Overpayment of Veteran's Benefits</p> <p><input type="checkbox"/> 160 Stockholders' Suits</p> <p><input type="checkbox"/> 190 Other Contract</p> <p><input type="checkbox"/> 195 Contract Product Liability</p> <p><input type="checkbox"/> 196 Franchise</p> <p><b>REAL PROPERTY</b></p> <p><input type="checkbox"/> 210 Land Condemnation</p> <p><input type="checkbox"/> 220 Foreclosure</p> <p><input type="checkbox"/> 230 Rent Lease &amp; Ejectment</p> <p><input type="checkbox"/> 240 Torts to Land</p> <p><input type="checkbox"/> 245 Tort Product Liability</p> <p><input type="checkbox"/> 290 All Other Real Property</p>	<p><b>TORTS</b></p> <p><b>PERSONAL INJURY</b></p> <p><input type="checkbox"/> 310 Airplane</p> <p><input type="checkbox"/> 315 Airplane Product Liability</p> <p><input type="checkbox"/> 320 Assault, Libel &amp; Slander</p> <p><input type="checkbox"/> 330 Fed. Employers' Liability</p> <p><input type="checkbox"/> 340 Marine</p> <p><input type="checkbox"/> 345 Marine Product Liability</p> <p><input type="checkbox"/> 350 Motor Vehicle</p> <p><input type="checkbox"/> 355 Motor Vehicle Product Liability</p> <p><input type="checkbox"/> 360 Other Personal Injury</p> <p><input type="checkbox"/> 362 Personal Injury-Med Malpractice</p> <p><input type="checkbox"/> 365 Personal Injury-Product Liability</p> <p><input type="checkbox"/> 368 Asbestos Personal Injury Product Liability</p> <p><b>IMMIGRATION</b></p> <p><input type="checkbox"/> 462 Naturalization Application</p> <p><input type="checkbox"/> 463 Habeas Corpus-Alien Detainee</p> <p><input type="checkbox"/> 465 Other Immigration Actions</p>	<p><b>TORTS</b></p> <p><b>PERSONAL PROPERTY</b></p> <p><input type="checkbox"/> 370 Other Fraud</p> <p><input type="checkbox"/> 371 Truth in Lending</p> <p><input type="checkbox"/> 380 Other Personal Property Damage</p> <p><input type="checkbox"/> 385 Property Damage Product Liability</p> <p><b>BANKRUPTCY</b></p> <p><input type="checkbox"/> 422 Appeal 28 USC 158</p> <p><input type="checkbox"/> 423 Withdrawal 28 USC 157</p> <p><b>CIVIL RIGHTS</b></p> <p><input type="checkbox"/> 441 Voting</p> <p><input type="checkbox"/> 442 Employment</p> <p><input type="checkbox"/> 443 Housing/Accommodations</p> <p><input type="checkbox"/> 444 Welfare</p> <p><input type="checkbox"/> 445 American with Disabilities - Employment</p> <p><input type="checkbox"/> 446 American with Disabilities - Other</p> <p><input type="checkbox"/> 440 Other Civil Rights</p>	<p><b>PRISONER PETITIONS</b></p> <p><input type="checkbox"/> 510 Motions to Vacate Sentence</p> <p><input type="checkbox"/> 530 Habeas Corpus</p> <p><input type="checkbox"/> 530 General</p> <p><input type="checkbox"/> 535 Death Penalty</p> <p><input type="checkbox"/> 540 Mandamus/Other</p> <p><input type="checkbox"/> 550 Civil Rights</p> <p><input type="checkbox"/> 555 Prison Condition</p> <p><b>FORFEITURE / PENALTY</b></p> <p><input type="checkbox"/> 610 Agriculture</p> <p><input type="checkbox"/> 620 Other Food &amp; Drug</p> <p><input type="checkbox"/> 625 Drug Related</p> <p><input type="checkbox"/> 625 Seizure of Property 21 USC 881</p> <p><input type="checkbox"/> 630 Liquor Laws</p> <p><input type="checkbox"/> 640 R.R. &amp; Truck</p> <p><input type="checkbox"/> 650 Airline Regs</p> <p><input type="checkbox"/> 660 Occupational Safety/Health</p> <p><input type="checkbox"/> 690 Other</p>	<p><b>LABOR</b></p> <p><input type="checkbox"/> 710 Fair Labor Standards Act</p> <p><input type="checkbox"/> 720 Labor/Mgmt. Relations</p> <p><input type="checkbox"/> 730 Labor/Mgmt. Reporting &amp; Disclosure Act</p> <p><input type="checkbox"/> 740 Railway Labor Act</p> <p><input type="checkbox"/> 790 Other Labor Litigation</p> <p><input type="checkbox"/> 791 Empl. Ret. Inc. Security Act</p> <p><b>PROPERTY RIGHTS</b></p> <p><input type="checkbox"/> 820 Copyrights</p> <p><input checked="" type="checkbox"/> 830 Patent</p> <p><input type="checkbox"/> 840 Trademark</p> <p><b>SOCIAL SECURITY</b></p> <p><input type="checkbox"/> 861 HIA (1395ff)</p> <p><input type="checkbox"/> 862 Black Lung (923)</p> <p><input type="checkbox"/> 863 DIWC/DIWW (405(g))</p> <p><input type="checkbox"/> 864 SSID Title XVI</p> <p><input type="checkbox"/> 865 RSI (405(g))</p> <p><b>FEDERAL TAX SUITS</b></p> <p><input type="checkbox"/> 870 Taxes (U.S. Plaintiff or Defendant)</p> <p><input type="checkbox"/> 871 IRS-Third Party 26 USC 7609</p>
--	---	---	--	--	---

ED CV 09 - 01300 SGL (OPx)

FOR OFFICE USE ONLY: Case Number: \_\_\_\_\_

AFTER COMPLETING THE FRONT SIDE OF FORM CV-71, COMPLETE THE INFORMATION REQUESTED BELOW.



VIII(a). **IDENTICAL CASES:** Has this action been previously filed in this court and dismissed, remanded or closed?  No  Yes  
 If yes, list case number(s): \_\_\_\_\_

VIII(b). **RELATED CASES:** Have any cases been previously filed in this court that are related to the present case?  No  Yes  
 If yes, list case number(s): 09-cv-1437 (JFW)

**Civil cases are deemed related if a previously filed case and the present case:**

- (Check all boxes that apply)  A. Arise from the same or closely related transactions, happenings, or events; or  
 B. Call for determination of the same or substantially related or similar questions of law and fact; or  
 C. For other reasons would entail substantial duplication of labor if heard by different judges; or  
 D. Involve the same patent, trademark or copyright, and one of the factors identified above in a, b or c also is present.

**IX. VENUE:** (When completing the following information, use an additional sheet if necessary.)

(a) List the County in this District; California County outside of this District; State if other than California; or Foreign Country, in which **EACH** named plaintiff resides.  
 Check here if the government, its agencies or employees is a named plaintiff. If this box is checked, go to item (b).

County in this District:*	California County outside of this District; State, if other than California; or Foreign Country
TMI PRODUCTS, INC.: Riverside County, California	

(b) List the County in this District; California County outside of this District; State if other than California; or Foreign Country, in which **EACH** named defendant resides.  
 Check here if the government, its agencies or employees is a named defendant. If this box is checked, go to item (c).

County in this District:*	California County outside of this District; State, if other than California; or Foreign Country
ROSEN ENTERTAINMENT SYSTEMS, L.P.: Riverside County, California	

(c) List the County in this District; California County outside of this District; State if other than California; or Foreign Country, in which **EACH** claim arose.  
**Note: In land condemnation cases, use the location of the tract of land involved.**

County in this District:*	California County outside of this District; State, if other than California; or Foreign Country
Riverside County (California), and nationwide	

\* Los Angeles, Orange, San Bernardino, Riverside, Ventura, Santa Barbara, or San Luis Obispo Counties  
**Note: In land condemnation cases, use the location of the tract of land involved**

X. SIGNATURE OF ATTORNEY (OR PRO PER): Mary Barcelo Date July 9, 2009

**Notice to Counsel/Parties:** The CV-71 (JS-44) Civil Cover Sheet and the information contained herein neither replace nor supplement the filing and service of pleadings or other papers as required by law. This form, approved by the Judicial Conference of the United States in September 1974, is required pursuant to Local Rule 3-1 is not filed but is used by the Clerk of the Court for the purpose of statistics, venue and initiating the civil docket sheet. (For more detailed instructions, see separate instructions sheet.)

Key to Statistical codes relating to Social Security Cases:

Nature of Suit Code	Abbreviation	Substantive Statement of Cause of Action
861	HIA	All claims for health insurance benefits (Medicare) under Title 18, Part A, of the Social Security Act, as amended. Also, include claims by hospitals, skilled nursing facilities, etc., for certification as providers of services under the program. (42 U.S.C. 1935FF(b))
862	BL	All claims for "Black Lung" benefits under Title 4, Part B, of the Federal Coal Mine Health and Safety Act of 1969. (30 U.S.C. 923)
863	DIWC	All claims filed by insured workers for disability insurance benefits under Title 2 of the Social Security Act, as amended; plus all claims filed for child's insurance benefits based on disability. (42 U.S.C. 405(g))
863	DIWW	All claims filed for widows or widowers insurance benefits based on disability under Title 2 of the Social Security Act, as amended. (42 U.S.C. 405(g))
864	SSID	All claims for supplemental security income payments based upon disability filed under Title 16 of the Social Security Act, as amended.
865	RSI	All claims for retirement (old age) and survivors benefits under Title 2 of the Social Security Act, as amended. (42 U.S.C. (g))