

FILED LODGED ENTERED RECEIVED
JUL 19 2006 LK
AT SEATTLE
CLERK U.S. DISTRICT COURT
WESTERN DISTRICT OF WASHINGTON
DEPUTY

1
2
3
4
5
6
7
8
9
10
11
12
13
14
15
16
17
18
19
20
21
22
23
24

SEA 2704 Summ. 788u.

UNITED STATES DISTRICT COURT
FOR THE WESTERN DISTRICT OF WASHINGTON
AT SEATTLE

C06-1014 Rsm

NATIONAL PRODUCTS, INC.,

Civil Case No.

Plaintiff,

COMPLAINT

v.

DEMAND FOR JURY TRIAL

HEWLETT-PACKARD CO.,
BELKIN LOGISTICS, INC.,
BELKIN CORP., and
BELKIN LTD.,



Defendants.

06-CV-01014-CMP

Plaintiff National Products, Inc. ("NPI"), for its Complaint, states and alleges as follows:

THE PARTIES

1. NPI is a Washington corporation having a principal place of business at 1205 S. Orr Street, Seattle, WA 98108.

2. NPI is a market leader in the manufacture and sale of vehicle mounting systems. These devices generally allow a user to attach mobile devices, such as cellular phones, global positioning system ("GPS") devices, and handheld and notebook computers, to the interior of vehicles (e.g., cars, trucks, airplanes and boats). They can also be repositioned to adjust the angle or height of the devices. These vehicle mounting systems

1 are popular with commercial fleets, police departments, the military, sportsmen, and many
2 other consumers.

3 3. Upon information and belief, Defendant Hewlett-Packard Co. is a Delaware
4 corporation having its principal place of business at 3000 Hanover Street, Palo Alto, CA
5 94304.

6 4. Upon information and belief, Defendant Belkin Logistics, Inc., is a Delaware
7 corporation having its principal place of business at 501 West Walnut Street, Compton, CA
8 90220-5221.

9 5. Upon information and belief, Defendant Belkin Corp. is a Delaware
10 corporation having its principal place of business at 501 West Walnut Street, Compton, CA
11 90220-5221.

12 6. Upon information and belief, Defendant Belkin Ltd. is a British limited
13 liability company having its principal place of business at Bryan Cave, 33 Cannon Street
14 London EC4M 5TE, UK.

15 **JURISDICTION AND VENUE**

16 7. This is an action for patent infringement arising under the Acts of Congress
17 relating to patents, 35 U.S.C. §§ 271, 281-285.

18 8. This Court has subject matter jurisdiction under 28 U.S.C. §§ 1331 and
19 1338(a).

20 9. Venue is proper in this judicial district under 28 U.S.C. §§ 1391 and 1400(b).

21 **THE '420 PATENT**

22 10. On December 23, 2003, U.S. Patent No. 6,666,420 ("the '420 patent"),
23 entitled "Suction cup having compact axial installation and release mechanism," was issued
24 to the inventor Jeffrey D. Carnevali ("Carnevali"). A copy of the '420 patent is attached as

1 Exhibit A. The '420 patent is generally directed towards a suction cup and components that
2 allow a device to be attached to a surface, for example, to a vehicle windshield.

3 11. Carnevali has duly assigned all right, title and interest in the '420 patent to
4 NPI, and NPI is the current owner of all right, title, and interest in the '420 patent.

5 **COUNT I - PATENT INFRINGEMENT**

6 12. NPI realleges and reincorporates the allegations in paragraphs 1-11 above.

7 13. Defendants Hewlett-Packard Co., Belkin Logistics, Inc., Belkin Corp. and
8 Belkin Ltd. (collectively, "Defendants") have infringed the '420 patent by making, using,
9 selling, offering to sell and importing infringing products, including without limitation the HP
10 iPAQ Window Mount, and by contributing to and inducing such infringement, including
11 acts within this judicial district.

12 14. Defendants' infringement of the '420 patent has caused NPI irreparable
13 harm, and NPI will continue to suffer irreparable harm in the future unless Defendants are
14 enjoined from infringing the '420 patent.

15 **PRAYER FOR RELIEF**

16 WHEREFORE, NPI prays for the following relief:

- 17 a. A judgment that Defendants have infringed the '420 patent;
- 18 b. An order preliminarily and permanently enjoining and restraining
19 Defendants, their officers, directors, agents, servants, employees, licensees, attorneys, and
20 all other persons acting under or through them, directly or indirectly, from infringing the
21 '420 patent;
- 22 c. A judgment and order requiring that Defendants pay damages under
23 35 U.S.C. § 284 with prejudgment interest.
- 24

1 d. A judgment and order directing Defendants to pay the costs of this
2 action (including all disbursements).

3 e. Such other and further relief as the Court may deem just and
4 equitable.

5 **DEMAND FOR JURY TRIAL**

6 NPI hereby demands a trial by jury of all issues so triable.

7
8 NATIONAL PRODUCTS, INC.

9 By its attorneys,

10 

11 DATED: July 19, 2006

12 David K. Tellekson, WSBA No. 33523
13 Robert L. Jacobson, WSBA No. 30838
14 DARBY & DARBY P.C.
15 1191 Second Avenue
16 Seattle, Washington 98101
17 Telephone: 206.262.8900
18 Facsimile: 206.262.8901
19 Email: dtellekson@darbylaw.com
20
21
22
23
24

Exhibit A

(12) **United States Patent**
Carnevali

(10) **Patent No.:** **US 6,666,420 B1**
 (45) **Date of Patent:** **Dec. 23, 2003**

(54) **SUCTION CUP HAVING COMPACT AXIAL INSTALLATION AND RELEASE MECHANISM**

6,045,111 A * 4/2000 Hsieh 248/551
 5,193,197 B1 * 2/2001 Lian 248/206.2
 6,478,271 B1 * 11/2002 Mulholland 248/205.8

(76) **Inventor:** **Jeffrey D. Carnevali, 3262 - 36th Ave. SW., Seattle, King County, WA (US) 98126**

FOREIGN PATENT DOCUMENTS

AU 0159046 * 4/1953
 FR 2347563 * 11/1977
 GB 0813265 * 5/1959
 GB 0906624 * 9/1962
 GB 0975271 * 11/1964
 GB 1193899 * 6/1970
 JP 405220042 * 8/1993

(*) **Notice:** Subject to any disclaimer, the term of this patent is extended or adjusted under 35 U.S.C. 154(b) by 0 days.

* cited by examiner

(21) **Appl. No.:** **10/374,437**

Primary Examiner—Anita King

(22) **Filed:** **Feb. 25, 2003**

(74) *Attorney, Agent, or Firm*—Charles J. Rupnick

(51) **Int. Cl.**7 **A47G 1/17**

(52) **U.S. Cl.** **248/205.8; 248/363**

(58) **Field of Search** **248/205.8, 205.5, 248/205.6, 205.7, 206.2, 363, 362**

(57) **ABSTRACT**

A suction cup device including a housing having a recess formed in a first surface, a drive surface external to and aligned with the recess, an aperture communicating between the housing drive surface and the recess; a suction cup; a drive shaft coupled to a central portion of the suction cup and sized to pass through the aperture in the housing; a rotational drive member having a cooperating drive surface structured to cooperate with the housing drive surface, a spiral installation drive surface aligned with the cooperating drive surface and relatively inclined thereto, and an aperture communicating between the cooperating and spiral installation drive surfaces and sized to slidingly engage the drive shaft; and a drive pin fixed crosswise to the drive shaft and spaced away from the suction cup, the drive pin structured to interact with the spiral installation drive surface of the rotational drive member.

(56) **References Cited**

U.S. PATENT DOCUMENTS

1,871,113 A * 8/1932 Compter et al. 248/205.8
 2,089,714 A * 8/1937 Schuler 248/363
 2,542,101 A * 2/1951 Suben 248/205.8
 2,940,713 A * 6/1960 Van Dusen 248/205.1
 3,765,638 A * 10/1973 Harrison 248/363
 3,863,568 A * 2/1975 Frederick 248/205.8
 4,093,165 A * 6/1978 Sussman 248/106
 4,934,641 A * 6/1990 McElhaney 248/205.2
 5,029,786 A * 7/1991 Wu 248/205.7
 5,065,973 A * 11/1991 Wung 248/362
 5,087,005 A * 2/1992 Holoff et al. 248/205.8
 5,104,077 A * 4/1992 Liu 248/205.8
 5,381,990 A * 1/1995 Belokin et al. 248/205.9
 5,992,806 A * 11/1999 Adams 248/205.8

20 Claims, 6 Drawing Sheets

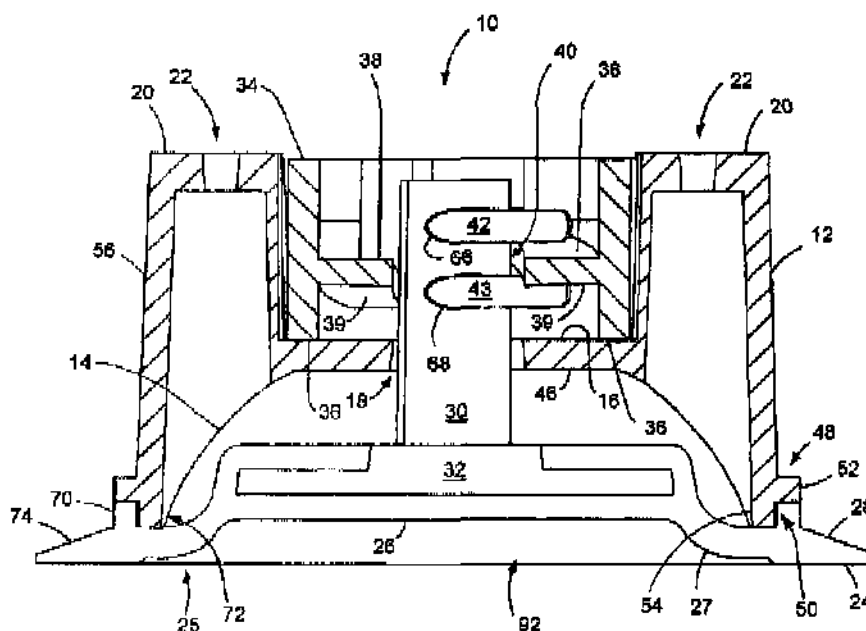

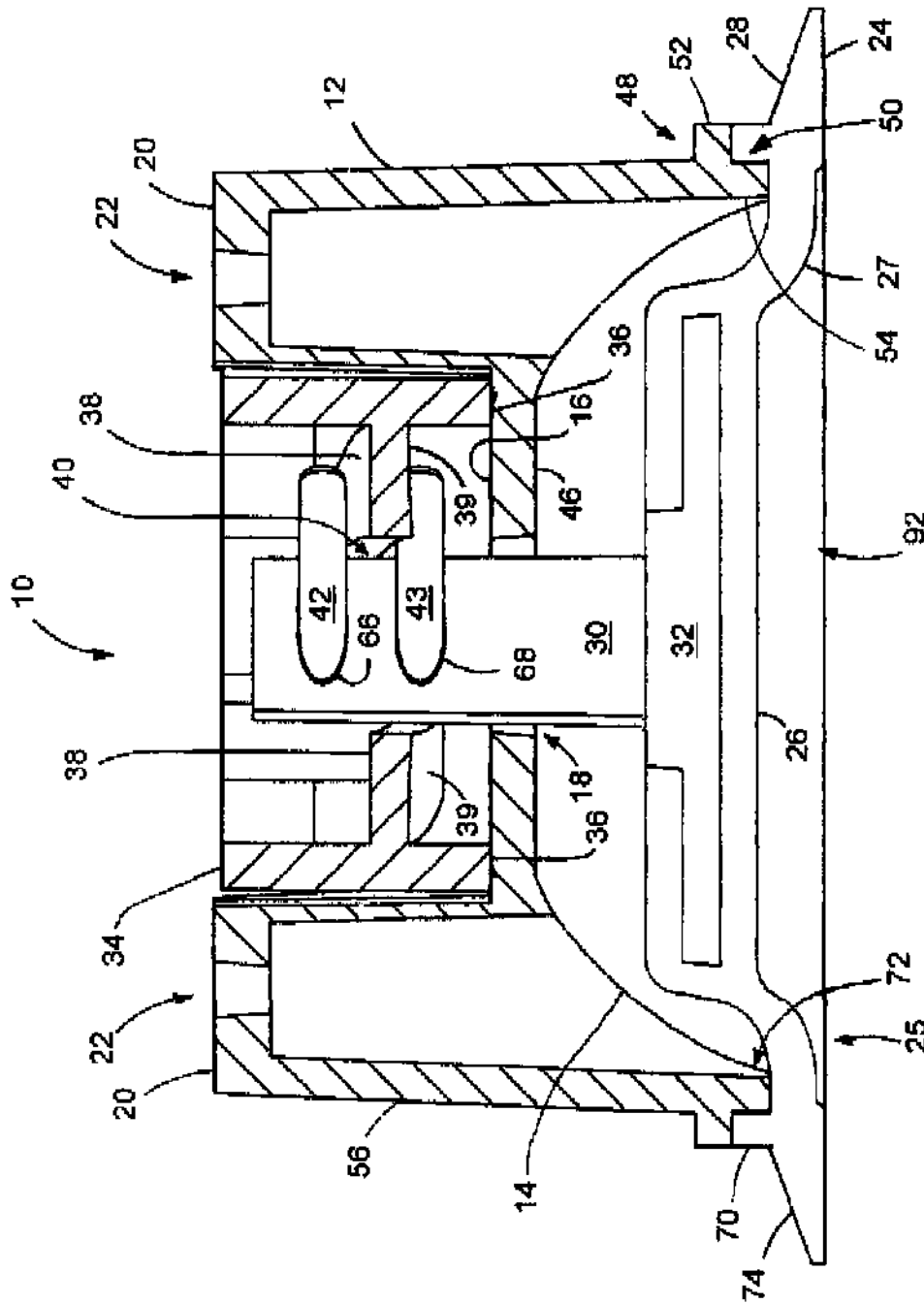

Fig. 1

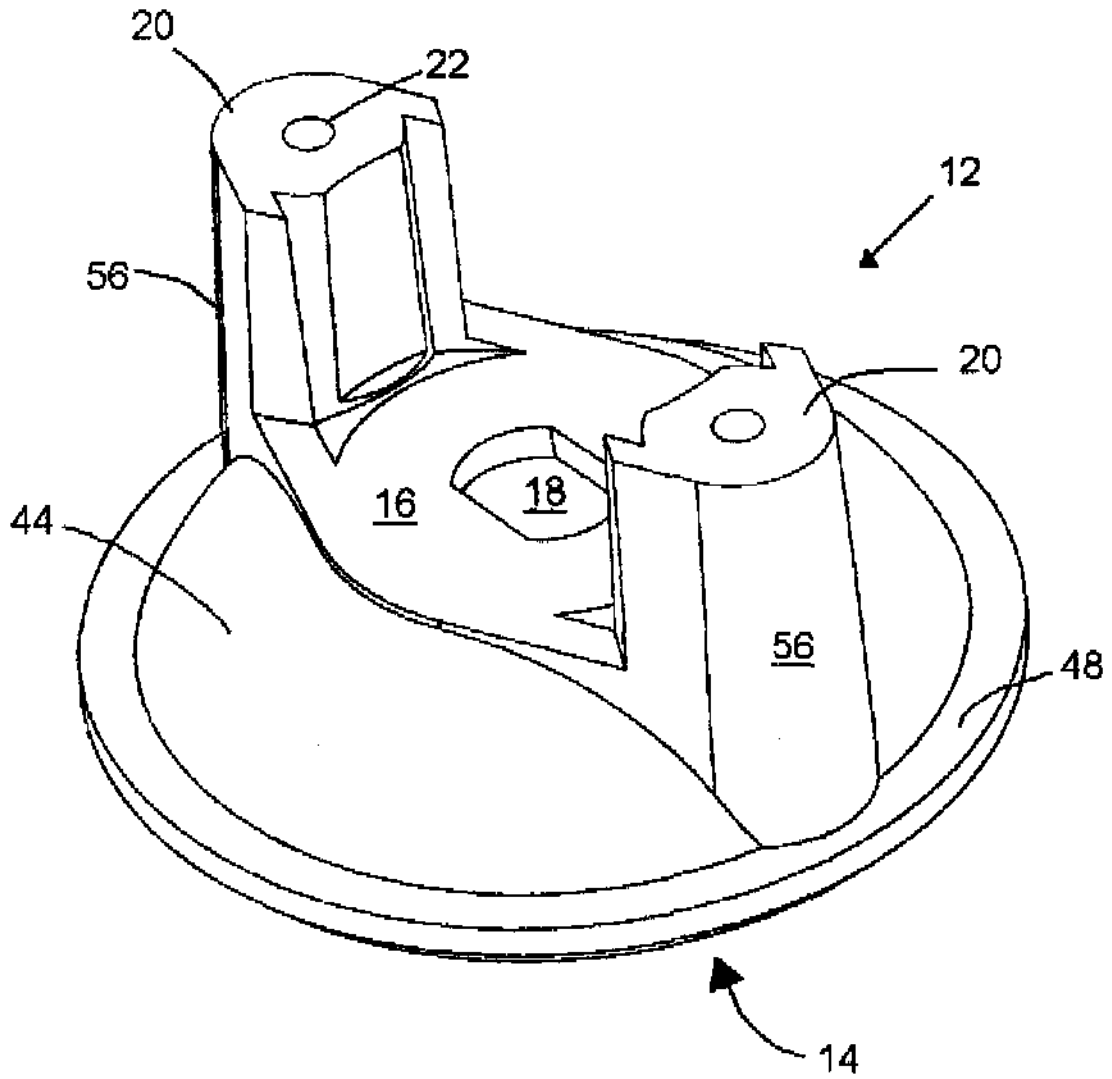

Fig. 2

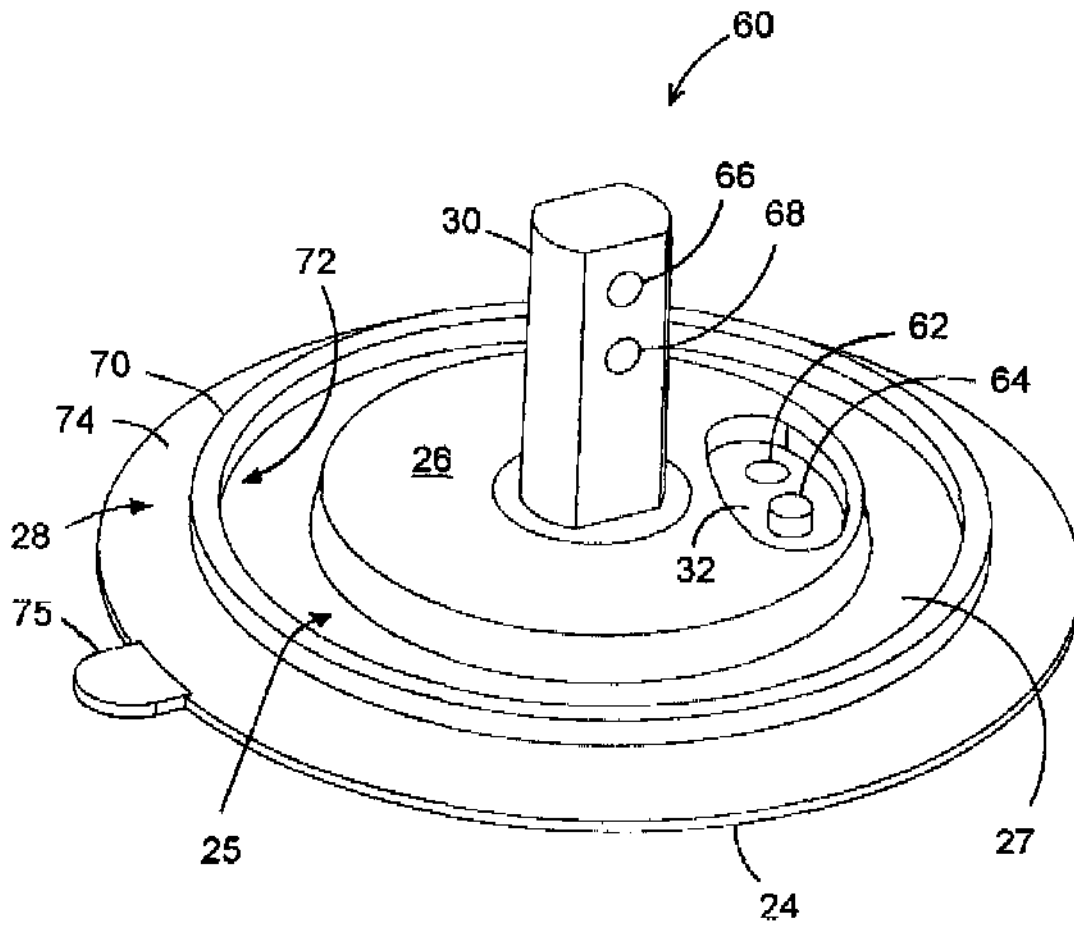

Fig. 3

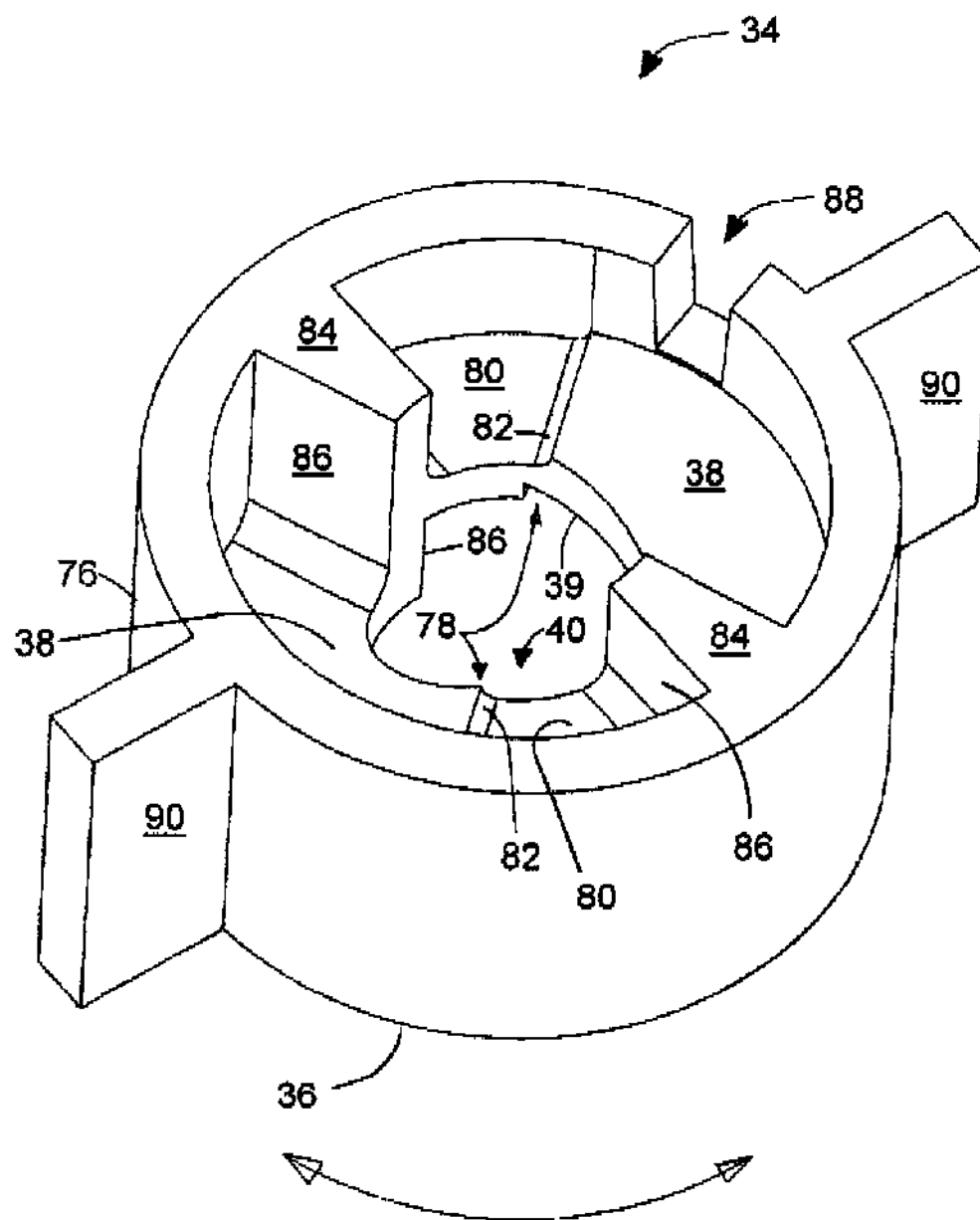

Fig. 4

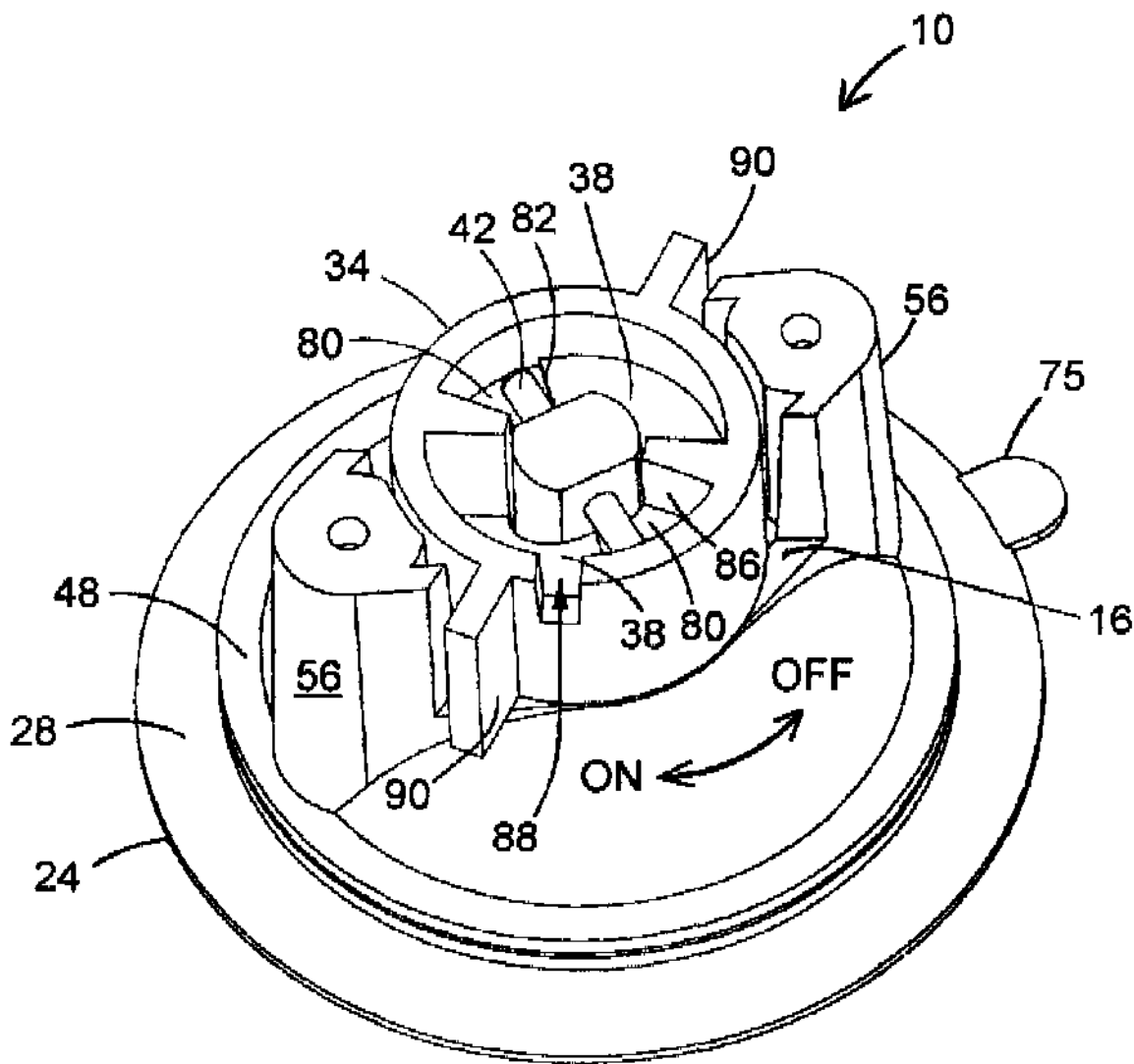

Fig. 5

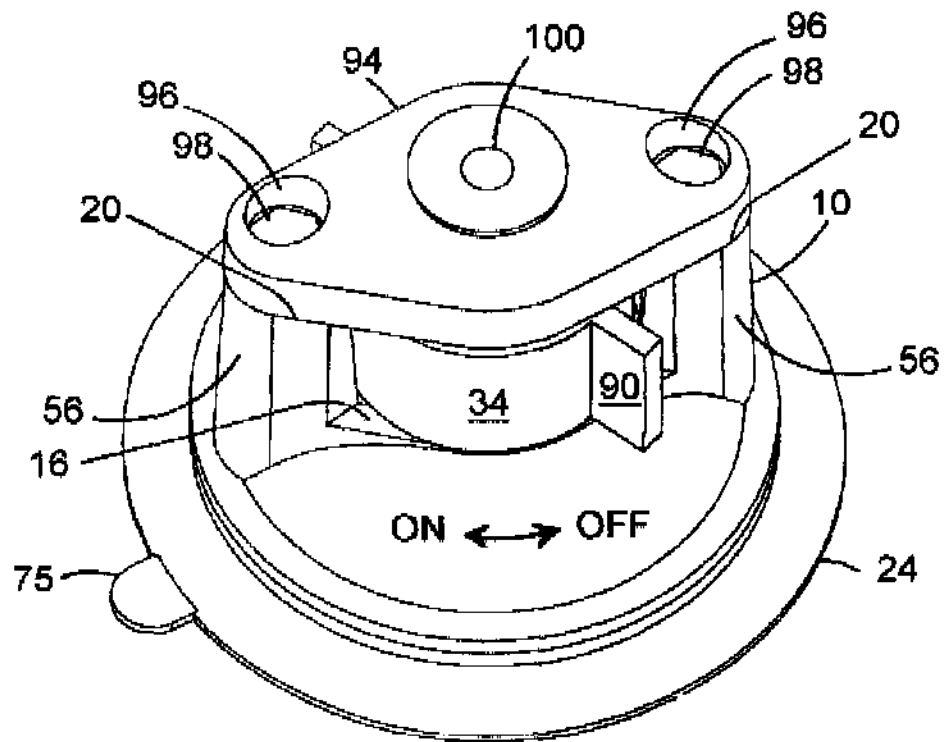

Fig. 6

US 6,666,420 B1

1

SUCTION CUP HAVING COMPACT AXIAL INSTALLATION AND RELEASE MECHANISM

FIELD OF THE INVENTION

The present invention relates to the field of suction cups, and in particular to axial suction cup installation and release devices and methods.

BACKGROUND OF THE INVENTION

Suction cups are generally well-known and commonly used to mount and secure objects to smooth surfaces such as the surfaces of glass, plastic, Formica, glazed tile, metal, and other smooth surfaces. A typical suction cup includes a cup body and a stem. The cup body is generally arcuate or circular and defines a concavity. Typically, the stem is integrally formed on the body and used as the place of attachment for the object to be supported by the suction cup. At least the body of the suction cup is made of rubber, plastic or other material having sufficiently elastically resilient properties such that, when the body is pressed against a smooth surface, the volume of concavity is reduced, thereby forcing air to be expelled so that the body forms an air-tight seal against the smooth surface. Atmospheric pressure outside the body retains the suction cup body against the surface. When the air-tight seal is broken, air rushes into the concavity, releasing the vacuum and the suction attachment to the surface. Whereupon the elastically resilient material of the suction cup body returns to its relaxed condition. The resilient suction cup can be repeatedly reused.

Suction cups are difficult to properly position. Once a suction cup is attached to a surface, the suction forces (atmospheric and friction) resist repositioning of the cup. Attachment of the suction cup to an object can also be a problem. Preferably, the attachment should be releasable.

Furthermore, the vacuum within the suction cup resists the resilient force of the body so that the force of suction balances the resilient force of the body of the suction cup. The result is a limit on the degree of vacuum which can be achieved.

One way this limitation on the vacuum can be at least partially overcome is by "pulling" the center of the suction cup body away from the surface, thereby at least partially overcoming the restraining effect of the vacuum and generating an even greater vacuum. The periphery of the suction cup forms an air-tight seal with the surface. When the center of the suction cup body is pulled resiliently away from the surface, a partial vacuum is formed between the body and the surface so that the suction cup body "sticks" to the surface. The greater the vacuum the better the cup sticks to the surface.

Several devices have been proposed to "pull" the center of the suction cup away from the surface in order to increase the suction. The most common arrangement, often found for example on the bases of pencil sharpeners and many kitchen appliances, involves a rod or crankshaft which extends mainly parallel to the surface to which the suction cup is to adhere. The center of the suction cup is attached to an eccentric section of the rod or crankshaft, and when a lever arm is turned, the center of the suction cup is pulled outward. U.S. Pat. No. 2,508,714, HOLDING DEVICE; issued Aug. 10, 1937, to Schuler; U.S. Pat. No. 3,765,638, SUCTION MOUNT, issued Oct. 16, 1973, to Harrison; and U.S. Pat. No. 4,934,641, CURVED SURFACE SUCTION MOUNTING APPARATUS, issued Jun. 19, 1990, to

2

McElhaney, all of which are incorporated herein by reference, all describe such shaft-based arrangements.

One problem with arrangements using crankshafts and eccentric rods is the lever arms which extend out from whatever device they are mounted in. The lever arms is all too easy to hit or snagged, and the suction is thereby accidentally released. Another drawback of lever arms is that the support and bearing structure for them is difficult to integrate into the structure of the device which is utilizing the suction cups. This complication increases costs and the likelihood of failure.

A further cause of increased costs associated with such suction cup assemblies according to the prior art is that they usually require suction cups that must be specially designed to accommodate the lever arms, crankshafts, and the like.

More recently, U.S. Pat. No. 5,087,005, TWIST-CAM SUCTION CUP ASSEMBLY, issued Feb. 11, 1992, to Holooff, et al. and U.S. Pat. No. 5,381,990, RELEASABLE SUCTION CUP ASSEMBLY, issued Jan. 17, 1995, to Belokin, et al., both incorporated herein by reference, proposed devices for "pulling" the center of the suction cup axially.

Holooff, et al., for example, discloses a suction cup assembly having a suction cup, a cam member, a cone member and a mating core member secured to the suction cup. The cone member has an outer periphery generally co-extensive with an outer portion of the suction cup, and a generally cylindrical inner opening closely enclosing a cylindrical outer surface of the core member. The cam member has generally cylindrical camming surfaces, and is mounted onto and closely engages either the core member or a camming flange on the cone member, depending on the embodiment. The cam member axially shifts the core member outward relative to the cone member by pulling the center of the suction cup away from a surface to which the suction cup may be adhered.

Belokin, et al. discloses a releasable suction cup formed by a cup body which has a duct passing therethrough and a valve element for opening the duct, whereby the vacuum holding the suction cup can be released for repositioning the suction cup. The valve extends through the duct and is threaded on one end to receive a threaded fastener which is used to move the valve element into a sealing position and to secure the suction cup to an object.

The axial suction cup devices of Holooff, et al. and Belokin, et al. and others however are overly complex to manufacture, assemble and operate, as well as suffering other limitations.

SUMMARY OF THE INVENTION

A compact axially-driven suction cup installation mechanism including a substantially rigid rotational drive mechanism having a tubular frame forming a substantially planar drive surface at one end thereof, a pair of diametrically opposed spiral installation drive members projecting inwardly from an internal wall surface of the tubular frame and being supported at first and second ends by a pair of diametrically opposed longitudinal stanchions projecting inwardly from the internal wall surface of the tubular frame, internal edge surfaces of the spiral installation drive members and longitudinal stanchions forming a longitudinal aperture axially aligned with the internal wall surfaces of the tubular frame, and means for manually rotating the tubular frame; a housing having a substantially planar external drive surface formed with an aperture therethrough and being structured to cooperate with the substantially planar drive

US 6,666,420 B1

3

surface of the rotational drive mechanism; and a columnar drive shaft structured to travel through the longitudinal aperture of the rotational drive mechanism, a first end of the columnar drive shaft including means for connecting to a suction cup and a second end of the columnar drive shaft including means for interacting with one or both of the pair of spiral installation drive members for moving the columnar drive shaft through the longitudinal aperture of the rotational drive mechanism in an outwardly direction relative to the planar drive surface thereof

According to one aspect of the invention, the means of the columnar drive shaft for interacting with the spiral installation drive members of the rotational drive mechanism is structured as a rigid installation drive pin installed crosswise to the columnar drive shaft.

According to another aspect of the invention, the means for connecting to a suction cup includes a structure adapted for being molded into the suction cup.

According to another aspect of the invention, a suction cup having a central attachment portion is included, the central attachment portion being coupled to the suction cup connecting means of the columnar drive shaft.

According to another aspect of the invention, the housing includes a concavity positioned on a surface opposite from the external drive surface thereof and is structured to admit a central flexible portion of a suction cup, the aperture communicating between the external drive surface and the concavity.

According to another aspect of the invention, the rotational drive mechanism further includes a pair of diametrically opposed spiral release drive members each projecting inwardly from an internal wall surface of the tubular frame on an opposite surface of the spiral installation drive members and being supported at first and second ends by the pair of diametrically opposed longitudinal stanchions projecting inwardly from the internal wall surface of the tubular frame; and the second end of the columnar drive shaft further includes means for interacting with one or both of the pair of spiral release drive members for moving the columnar drive shaft through the longitudinal aperture of the rotational drive mechanism in a second direction relative to the planar drive surface thereof opposite from the first direction. The means of the columnar drive shaft for interacting with the spiral release drive members of the rotational drive mechanism is, for example, a rigid release drive pin installed crosswise to the columnar drive shaft at a position between the installation drive pin and the means for connecting to a suction cup.

According to another aspect of the invention, the housing includes a utilization mounting surface structured as a pattern of mounting holes spaced away from the housing planar drive surface a distance sufficient to admit the rotational drive mechanism therebetween.

BRIEF DESCRIPTION OF THE DRAWINGS

The foregoing aspects and many of the attendant advantages of this invention will become more readily appreciated as the same becomes better understood by reference to the following detailed description, when taken in conjunction with the accompanying drawings, wherein:

FIG. 1 is a partial cutaway view of the invention embodied in a suction cup device having a compact axially-driven suction cup installation and release mechanism;

FIG. 2 illustrates the suction cup housing of the invention embodied as a shallow "bell" shaped body an under surface

4

of which is formed with a concave cavity structured to cooperate with the suction cup of the invention;

FIG. 3 illustrates the suction cup and drive shaft of the invention embodied in a plunger assembly;

FIG. 4 illustrates one embodiment of the spiral axial drive member of the invention that is mounted on the drive shaft illustrated in FIG. 1;

FIG. 5 illustrates the suction cup device of the invention for describing the assembly and operation of the device; and

FIG. 6 illustrates the suction cup device of the invention having a device mounting structure installed on a utilization mounting surface thereof.

DETAILED DESCRIPTION OF PREFERRED EMBODIMENT

In the Figures, like numerals indicate like elements.

The terms "up" and "down" and derivatives are used solely for clarity in describing the invention and relate to the relative orientation of the individual components shown in the Figures and the assembly relative to a surface to which it is attached.

The present invention is an apparatus and method for a suction cup device having a compact axial suction cup installation and release mechanism. The suction cup device includes a suction cup within a concave housing, and an axial drive member structured to operate on an external surface of the housing. A drive shaft is coupled to a central portion of the suction cup and extends through an aperture in the housing, projecting above a drive surface axially aligned with the concave surface formed in the housing. The drive shaft extends through a central aperture in the axial drive member and interacts with an inclined drive surface to pull the central portion of the suction cup toward and push it away from the concave surface of the housing when the axial drive member is rotated in first and second opposite directions relative to the housing.

FIG. 1 is a partial cutaway view of the invention embodied a suction cup device 10 having a compact axially-driven suction cup installation and release mechanism. Accordingly, the housing 12 is shown embodied by example and without limitation as having a substantially concave recess or cavity 14 formed in a first "suction" surface, a substantially planar reaction drive surface 16 formed on an opposite external surface of the housing 12 from, and axially aligned with, the concave cavity 14. An axial aperture 18 communicates between the housing drive surface 16 and the concave cavity 14. The suction cup device 10 according to the invention is intended to secure some device—a "utilization device"—to a surface. Therefore, a utilization mounting surface 20 is provided as a pattern of mounting holes raised above the operational features of the device. According to one embodiment of the invention, the utilization mounting surface 20 is formed external to the concave cavity 14 and spaced far enough from the housing drive surface 16 to fit the compact axially-driven suction cup installation and release mechanism of the invention to fit therebetween. The utilization mounting surface 20 is formed, by example and without limitation, with a pair of spaced apart threaded mounting holes 22.

A suction cup 24 is provided having a resiliently deformable central suction portion 25 positioned within the concave cavity 14 of the housing 12 and the peripheral lip portion 28 positioned outside of the cavity 14.

A drive shaft 30 is sized to pass through the aperture 18 in the housing 12 and includes a thin disk-shaped foot

US 6,666,420 B1

5

portion 32 that is coupled to the central portion 25 of the suction cup 24.

A spiral rotational drive member 34 is mounted on the drive shaft 30. The rotational drive member 34 is formed having a first substantially planar drive surface 36 that, in operation, drives rotationally against the housing reaction drive surface 16. The rotational drive member 34 is further formed with an pair of upper spiral axial installation drive surfaces 38 that are axially aligned with the first planar drive surface 36 and are relatively inclined at substantially identical angles thereto, and a second pair of spiral axial release drive surfaces 39 are formed on the undersides of the installation drive surfaces 38 and have substantially the identical inclination relative to the housing reaction drive surface 16. A substantially round axial aperture 40 communicates between the planar drive surface 36 and the two inclined drive surfaces 38 and is sized to slidingly accept the axial drive shaft 30 therethrough. Installation and release drive pins 42, 43 are fixed crosswise to the drive shaft 30 and spaced away from the suction cup 24. The installation and release drive pins 42, 43 are structured to interact with the respective installation and release inclined drive surfaces 38, 39 of the axial drive member 30.

The suction cup housing 12, drive shaft 30 and rotational drive member 34 all may be manufactured easily and inexpensively as individual units of relatively rigid molded plastic. The installation and release drive pins 42, 43 are of a tough and sturdy material such as metal.

FIG. 2 illustrates the suction cup housing 12 embodied as a shallow "bell" shaped body 44 an under surface of which is formed with the concave cavity 14. As is more clearly shown in FIG. 1, the concave cavity 14 is by example and without limitation formed with a shallow semi-spherical shape that is further truncated at its inner surface by the substantially planar underside 46 of the drive surface 16. The cavity 14 is alternatively embodied as a shallow semi-spherical shape that maintains its curvature across the underside 46 of the drive surface 16. According to another alternative embodiment, the concavity 14 is embodied as a shallow "funnel" shape that either maintains its shape to the underside 46 of the reaction drive surface 16, or is truncated at its inner surface by the substantially planar underside 46 of the reaction drive surface 16.

The drive surface 16 is embodied as a substantially planar surface that truncates the semi-spherical exterior of the housing 12 at a position opposite from the concave cavity surface 14 and spaced apart from it by the thickness of the housing body 44. The drive surface 16 is further axially aligned with the concavity 14. The aperture 18 communicating between the reaction drive surface 16 and its underside 46 within the concavity 14 is structured to limit relative rotation of the drive shaft 30. For example, the aperture 18 is formed as a generally square or rectangular slot, although other anti-rotational shapes may be used such as oblongs, stars, kidneys and free forms. According to one embodiment, the shape of the aperture 18 follows the generally round overall theme of the axially-driven suction cup device 10 of the invention having the short sides of the rectangular slot curved or arched substantially concentric with the bell-shaped housing body 44 and the concavity 14 formed therein.

A peripheral lip portion 48 formed concentrically with the bell-shaped housing body 44 is constructed to hold the peripheral lip portion 28 of the suction cup 24 smooth, flat annular ring concentric with the housing body 44 and positioned external to the concavity 14. As is more clearly

6

shown in FIG. 1, the lip portion 48 includes an annular groove 50 between concentric outward and downward projecting portions 52, 54 for capturing a thick and portion of the suction cup lip 28. The downward projecting portion 54 of the housing lip 48 keeps the suction cup lip 28 from being drawn into the concavity 14 during installation of the suction cup device 10, while the outwardly projecting portion 52 helps to keep the suction cup lip 28 from curling.

The suction cup housing 12 includes the utilization mounting surface 20 formed, for example, as a pair of spaced apart columns 56 diametrically opposed from one another on either side of the drive surface 16 and projecting upwardly from the external surface of the bell-shaped housing body 44. The columns 56 are sized and shaped to provide sufficient stiffness against side loading expected of the application for which suction cup device 10 is intended. The utilization mounting surfaces 20 are substantially co-planar surfaces formed substantially parallel with the drive surface 16 and disposed on the ends of the columns 56 distal from the housing body 44. Each of the utilization mounting surfaces 20 includes means 22 for attaching thereto. For example, the attaching means 22 are embodied as threaded holes or through holes backed up with embedded or free-floating metal hex nuts or another threaded insert.

FIG. 3 illustrates the suction cup 24 and the drive shaft 30 embodied in a plunger assembly 60. As is more clearly shown in FIG. 1, the drive shaft 30 includes an integral disk-shaped foot portion 32 expanding outwardly from one end of the column-shaped body of the drive shaft 30. The circular foot portion 32 is provided with means 62, 64 for adhering the moldable suction cup material thereto. For example, the adhering means 62, 64 (shown in cutaway) are embodied as a pattern of depressions or holes and short columnar projections, respectively, that may be present individually or in combination (shown). The columnar drive shaft 30 is sized to pass through the aperture 18 in the suction cup housing 12 and is shaped to cooperate with the aperture 18 for maintaining a constant relative rotational orientation, and thus remains rotationally oriented to the suction cup housing 12 during operation. In the example shown, the columnar drive shaft 30 generally rectangular in cross-section and is sized to slidingly engage the aperture 18. The columnar drive shaft 30 also includes one or a pair of spaced-apart crosswise through holes 66, 68 at intervals along its length, the hole 66 more proximate to the distal end of the drive shaft 30 is provided for the installation drive pin 42, while the more distal through hole 68 is provided for the release drive pin 43, as discussed below.

The suction cup 24 is a rubber, plastic or another elastically resilient material molded over the circular foot portion 32 of the drive shaft 30, as is more clearly shown in FIG. 1. The adhering means 62, 64 to improve and ensure adhesion of the molded suction cup material to the drive shaft foot portion 32. The central suction portion 25 of the suction cup 24 includes a relatively stiff round center section 26 formed of the elastically resilient material over molding the foot 32 of the drive shaft 30. The relatively stiff round center section 26 is surrounded by an integral thin deformably resilient annular portion of that extends to the integral peripheral lip portion 28. According to one embodiment of the invention, the peripheral lip portion 28 is an annular ring of the elastically resilient material structured to cooperate with the annular groove 50 of the housing body's lip 48 for keeping the peripheral lip 28 from being drawn into the concavity 14 during installation of the suction cup device 10. Accordingly, the lip portion 28 includes a thickened inner peripheral annular ring 70 that forms an annular "shell" 72

US 6,666,420 B1

7

structured to fit within the annular groove 50 between outwardly and downwardly projections 52, 54. The integral peripheral lip 28 may extend outwardly in a thickened annular ring portion 74 having a cross-section of sufficient thickness to avoid curling during installation of the suction cup device 10, thereby effectively increasing the suction cup footprint and the holding power of the suction cup device.

A tab 75 extends from the periphery of the annular ring portion 74 of the suction cup 24. When the suction cup is attached to a surface, manual lifting of the tab 75 by the operator eases release of the suction cup device 10.

Although less effective in operation than a rigid material, the drive shaft 30 is optionally molded of the plastic or other elastically resilient material from which the suction cup 24 is molded. Additionally, when molded of the same material as the suction cup 24, the drive shaft 30 is optionally molded integrally with the suction cup 24, and the foot portion 32 is eliminated.

FIG. 4 illustrates one embodiment of the spiral axial drive member 34 that is mounted on the drive shaft 30 in FIG. 1. As embodied in FIG. 4, the axial drive member 34 includes the substantially planar drive surface 36 embodied as an annular ring formed as one surface of a substantially tubular-walled body or frame 76 that is its main structural component. In the top-down perspective view of FIG. 1 the pair of upper spiral axial installation drive surfaces 38 are shown as a pair of diametrically-opposed annular inclined surfaces around the round axial aperture 40. The installation drive surfaces 38 are offset above respective spiral axial release drive surfaces 39 and cover a vertical distance relative to the tubular walls of the frame 76 that is configured to create a substantial vacuum between the deformable central portion 25 of the suction cup 24 and a surface to which it is attached. The lower release drive surfaces 39 begin at a minimum position relative to the frame walls 76 that is offset above the planar drive surface 36 sufficiently to permit the release drive pin 43 to pass thereunder, as is more clearly shown in FIG. 1.

The spiral installation drive surfaces 38 are provided with anti-rotation "keeper" means 78. For example, the spiral installation drive surfaces 38 extend at their maximum elevation relative to the planar drive surface 36 in an extension or "shelf" portion 80 that is formed either substantially parallel with the planar drive surface 36 or canted at a slightly negative inclination relative to the respective installation drive surfaces 38. A "saddle" is optionally created by a shallow curve or "dish" shaped in shelf to operate as the anti-rotation locking mechanism. Irrespective of configuration, the installation drive and 42 rests on the shelf portion 80. A detent 82 is optionally formed between each installation drive surface 38 and the respective extension 80 as an offset or a steeply negatively inclined plane (shown).

The pairs of spiral installation and release drive surfaces 38, 39 end in a pair of stanchions 84 diametrically opposed across the axial aperture 40. Besides supporting the upper and lower ends of the installation and release surfaces, the stanchions 84 provide stops in the form of solid surfaces 86 for one or both of the installation and release drive pins 42, 43.

The rotational drive member 34 includes access means 88 for installing the installation drive pin 42 during assembly of the suction cup device 10 and its installation and release mechanism. For example, the access means 88 is embodied as a slot through the tubular wall of the frame 76 sized to pass the installation drive pin 42. The access slot 88 is positioned along the inclined installation drive surface 38

8

and a point adjacent to or actually in alignment with the extension 80 at the top of one of the installation drive surfaces 38 distal from the planar drive surface 36.

Additionally, the rotational drive member 34 includes operating means 90 for gripping and manually rotating it about its longitudinal axis, as indicated by the arrow, relative to the suction cup housing 12, whereby the inclined installation and drive surfaces 38, 39 are rotated relative to the respective rotationally fixed installation and release drive pins 42, 43 and the drive shaft 30 is driven-axially relative to the rotational drive member 34. The operating means 90 is embodied for example as a pair of diametrically opposed flanges projecting outwardly from the tubular walls of the frame 76, as illustrated in FIG. 4. Alternatively, the operating means 90 is embodied as another conventional manual gripping device or surface such as a knurled or grooved surface.

FIG. 5 illustrates the suction cup device 10, with the utilization of mounting surface 20 exposed. The illustration of FIG. 5 is useful in describing the assembly and operation of the suction cup device 10, including its compact axial suction cup installation and release mechanism. As illustrated, the suction cup 24 is installed with the deformable central suction portion 25 positioned within the concavity 14 of the housing 12, as more clearly shown in FIG. 1, and the peripheral lip portion 28 extending beyond the portion 48. As is also more clearly shown in FIG. 1, the columnar drive shaft 30 passes through the cooperating axial aperture 18 communicating between the interior surface 46 of the cavity 14 and the planar drive surface 16 of the suction cup housing 12.

If present, the release drive pin 43 is inserted into and partially through the more distal hole 68 through the drive shaft 30.

The round axial aperture 40 of the rotational drive member 34 is fitted over the end of the columnar drive shaft 30 projecting through the axial aperture 18 above the housing drive surface 16. The release drive pin 43 fitting between the tubular walls of the axial drive member frame 76. The respective pairs of inclined installation and release drive surfaces 38, 39 are thereby positioned on opposite sides of the drive shaft 30 with each of the release drive surfaces 39 in proximity to the portion of the release drive in projecting crosswise from opposite sides of the drive shaft 30. The planar drive surface 36 is positioned adjacent to and in contact with the housing reaction drive surface 16, as is more clearly shown in FIG. 1. The access means, slot 88, is aligned with the second crosswise hole 66 through the distal end of the drive shaft 30.

When the suction cup 24 is in a relaxed state, the positioning of the access slot at or near the top of the inclined installation drive surface 38 causes the second crosswise hole 66 in the drive shaft 30 to be slightly below the installation drive surfaces 38 of the axial drive member 34. It is therefore partially obscured and inaccessible. A slight pressure is applied to the center section 26 of the suction cup 24, and thereby to the foot portion 32 of drive shaft 30. The drive shaft 30 is thereby moved axially relative to the housing 12 and the axially-driven rotational drive member 34 so that the second crosswise hole 66 appears above the installation drive surfaces 38. The installation drive pin 42 is now passed through the slot 88 and is inserted into and partially through the hole 66 through the drive shaft 30. During assembly, the installation drive pin passes completely through the access slot 88 and thereafter fits between the tubular walls of the axial drive member frame 76. Upon

US 6,666,420 B1

9

release of the pressure against the suction cup center section 26, the resilient suction cup 24 attempts to return to its relaxed state. The drive shaft 30 is thereby pulled back through the axial aperture 40 in the rotational drive member 34 and the axial slot 18 in the housing 12, which generates a slight pressure between the installation drive pin 42 and the installation drive surfaces 38. This pressure is used to keep the installation drive pin 42 from backing out of the hole 66 and through the access slot 88. However, as the rotational drive member 34 is rotated to a release position, as discussed below, the installation drive pin 42 moves along the installation drive surfaces 38 downward relative to the rotational drive member 34, which releases the pressure and permits the suction cup 24 to return to its relaxed state.

In operation, with the rotational drive member 34 rotated to release pressure between the installation drive pin 42 and the inclined installation drive surface 38, the peripheral lip portion 28 of the relaxed suction cup 24 is placed against a smooth surface to which is to be attached. When the operator is satisfied with the position of the suction cup device 10 relative to the attachment surface, the torque load is applied via the flanges 90 to rotate the drive member frame 76 relative to the suction cup housing 12 in the installation direction indicated by the arrow marked "ON." During rotation, the installation drive pin 42 comes into contact with an upwardly ramping axial installation drive surfaces 38. Continued application of the torque load to the drive member frame 76 causes the installation drive pin to travel upwardly along the axial installation drive surfaces 38. The planar drive surface 36 forming the bottom surface of the axial drive member 34 is as is simultaneously rotated against the housing reaction drive surface 16. As the installation drive pin 42 travels upwardly along the installation drive surfaces 38, it is moved axially away from the housing reaction drive surface 16. The drive shaft 30 is simultaneously drawn upwardly through axial aperture 18 in the housing drive surface 16. The foot portion 32 is carried upwardly as part of the drive shaft 30. The center section 26 of the suction cup 24 is thus drawn up for delay with the foot portion 32 into the concavity 14 while the peripheral housing lip 48 maintains a manual or shape and position of the suction cup peripheral lip 28 external to the concavity 14. In effect, motion of the installation drive pin 42 upwardly along the installation drive surfaces 38 pulls the drive shaft 30 of the plunger 60 and out of the concavity 14 through the axial aperture 18 in the housing reaction drive surface 16. As the links of the plunger drive shaft 30 increases above the housing drive surface 16, the portion within the concavity 14 shortens. The thin deformably resilient annular portion 27 of the suction cup 24 is forced to stretch between the withdrawing center section 26 positionally fixed peripheral lip 28. An airtight cavity 92 (shown in FIG. 1) is formed beneath the suction cup wherein a partial vacuum is formed relative to ambient atmospheric pressure.

Rotation of the axially-driven drive member 34 ceases when the installation drive pin encounters the solid surface 86 of one or both of the stanchions 84. Other rotational stops may also be provided such as the flanges 90 encountering one of the columns 56 bearing the utilization mounting surfaces 20.

The pressure exerted by the installation drive pin 42 is maintained by its spaced apart position relative to the housing reaction drive surface 16. This relative position is maintained by the anti-rotation keeper means 78, whereby the installation drive pin 42 is settled on the extension or stop portion 80 at maximum elevation relative to the housing drive surface 16. Passing the installation drive pin 42 over

10

the optional detent 82, as well as the tension generated in the suction cup 24, ensures that the installation drive pin 42 cannot back down the installation drive surfaces 38.

The suction cup device 10 is released from the attachment surface by release of the relative vacuum within the suction cup 24. This is accomplished by collapsing the airtight cavity 92 by driving the center 26 of the suction cup 24 downwardly to the attachment surface, whereby tension in the stretched deformably resilient annular portion 27 is released and the suction cup 24 returns to its relaxed condition. The center 26 of the suction cup 24 is driven downwardly by interaction of the release drive pin 43 with the release drive surfaces 39 when the torque load is applied to rotate the drive member 34 in a release direction, as indicated by the arrow marked "OFF." For example, a released torque load is applied to the flanges 90 of the drive member frame 76. Force by the release drive pin 43 moving downwardly along the release drive surfaces 39 combines with the elasticity of the stretched deformably resilient annular portion 27 material to push the plunger drive shaft 30 down through the axial aperture 18 into the concavity 14. When the upward force on the plunger drive shaft 30 is completely removed and the suction cup 24 is relaxed, the relative vacuum holding the suction cup device 10 against the attachment surface is released and the device 10 can be moved.

FIG. 6 illustrates the suction cup device 10 of the invention having a device mounting structure 94 installed on the utilization mounting surfaces 20. The device mounting structure 94 includes means for attaching to the utilization mounting surfaces 20. For example, counter-bores and through holes 96 are provided for a fastener 98 to be threaded to the nut or insert provided at the mounting holes 22. The device mounting structure 94 includes, by example and without limitation, device mounting means such as a threaded or other capture hole 100.

The two-hole diamond shape of the device mounting structure 94 illustrated is not intended to be exhaustive and is shown as only one example and without limitation. The device mounting structure 94 is optionally embodied in any useful configuration. For example, the device mounting structure 94 is embodied suitably for mounting the resiliently compressible ball-shaped coupler described in U.S. Pat. No. 5,845,885, entitled UNIVERSALLY POSITIONABLE MOUNTING DEVICE, issued Dec. 8, 1998, to the inventor of the present invention, which is incorporated herein by reference. Alternatively, the device mounting structure 94 is embodied suitably for mounting the wheel-and-axle assembly of the positively-positionable mount described in allowed U.S. patent application Ser. No. 09/855,162, entitled POSITIVELY-POSITIONABLE MOUNTING APPARATUS, filed May 14, 2001, in the name of the inventor of the present invention, which is incorporated herein by reference.

According to another alternative, the device mounting structure 94 is embodied suitably for mounting either of the male and female mounting bases for use in combination with the flexible snap-link apparatus disclosed in U.S. patent application Ser. No. 09/654,245, entitled FLEXIBLE ELECTRONIC MOUNT APPARATUS, filed Sep. 2, 2000, in the name of the inventor of the present invention, which is incorporated herein by reference. Other alternative embodiments of the device mounting structure 94 are also contemplated for mounting a variety of different useful devices.

While the preferred embodiment of the invention has been illustrated and described, it will be appreciated that various

US 6,666,420 B1

11

changes can be made therein without departing from the spirit and scope of the invention.

What is claimed is:

1. A suction cup device having a compact axial installation and release mechanism, the suction cup device comprising:

a housing having a recess formed in a first surface, a drive surface external to and aligned with the recess, an aperture communicating between the housing drive surface and the recess;

a suction cup;

a drive shaft coupled to a central portion of the suction cup and being sized to pass through the aperture in the housing;

a rotational drive member having a cooperating drive surface structured to cooperate with the housing drive surface, a spiral installation drive surface aligned with the cooperating drive surface and relatively inclined thereto, and an aperture communicating between the cooperating and spiral installation drive surfaces and being sized to slidably engage the drive shaft; and

an installation drive pin fixed crosswise to the drive shaft and spaced away from the suction cup, the installation drive pin being structured to interact with the spiral installation drive surface of the rotational drive member.

2. The suction cup device of claim 1 wherein the housing further comprises a utilization mounting surface.

3. The suction cup device of claim 2 wherein the utilization mounting surface further comprises a pattern of mounting holes spaced away from the housing drive surface sufficiently to admit the rotational drive member therebetween.

4. The suction cup device of claim 1 wherein the spiral installation drive surface of the rotational drive member further comprises a pair of diametrically opposed spiral installation drive surfaces; and

the installation drive pin is further structured to interact with one or both of the spiral installation drive surfaces of the rotational drive member.

5. The suction cup device of claim 1 wherein the rotational drive member further comprises a spiral release drive surface formed opposite and spaced away from the spiral installation drive surface and inclined substantially similarly to the drive surface;

and further comprising a release drive pin fixed crosswise to drive shaft between the installation drive pin and the suction cup and being spaced away from the installation drive pin more than a distance between the spiral installation and release drive surfaces of the rotational drive member, the release drive pin being structured to interact with the spiral release drive surface of the rotational drive member.

6. The suction cup device of claim 1 wherein the spiral installation drive surface further comprises a means structured to interact with the installation drive pin for maintaining a position of the installation drive pin relative to the spiral installation drive surface.

7. A compact axially-driven suction cup installation mechanism, comprising:

a substantially rigid rotational-drive mechanism having a tubular frame forming a substantially planar drive surface at one end thereof, a pair of diametrically opposed spiral installation drive members projecting inwardly from an internal wall surface of the tubular frame and being supported at first and second ends by

12

a pair of diametrically opposed longitudinal stanchions projecting inwardly from the internal wall surface of the tubular frame, internal edge surfaces of the spiral installation drive members and the longitudinal stanchions forming a longitudinal aperture axially aligned with the internal wall surface of the tubular frame, and means for manually rotating the tubular frame;

a housing having a substantially planar external drive surface formed with an aperture therethrough and being structured to cooperate with the substantially planar drive surface of the rotational drive mechanism; and

a columnar drive shaft structured to travel through the longitudinal aperture of the rotational drive mechanism, a first end of the columnar drive shaft including means for connecting to a suction cup and a second end of the columnar drive shaft including means for interacting with one or both of the pair of spiral installation drive members for moving the columnar drive shaft through the longitudinal aperture of the rotational drive mechanism in an outwardly direction relative to the planar drive surface thereof.

8. The suction cup installation mechanism of claim 7 wherein the means of the columnar drive shaft for interacting with the spiral installation drive members of the rotational drive mechanism further comprises a rigid installation drive pin installed crosswise to the columnar drive shaft.

9. The suction cup installation mechanism of claim 7 wherein the means for connecting to a suction cup further comprises a structure adapted for being molded into the suction cup.

10. The suction cup installation mechanism of claim 7, further comprising a suction cup having a central attachment portion, the central attachment portion coupled to the suction cup connecting means of the columnar drive shaft.

11. The suction cup installation mechanism of claim 7 wherein the housing further comprises a concavity positioned on a surface of the housing opposite from the external drive surface thereof and structured to admit a central flexible portion of a suction cup, the aperture communicating between the external drive surface and the concavity.

12. The suction cup installation mechanism of claim 7 wherein the rotational drive mechanism further comprises a pair of diametrically opposed spiral release drive members projecting inwardly from the internal wall surface of the tubular frame on an opposite surface of the spiral installation drive members and being supported at first and second ends by the pair of diametrically opposed longitudinal stanchions projecting inwardly from the internal wall surface of the tubular frame; and

the second end of the columnar drive shaft further comprises means for interacting with one or both of the pair of spiral release drive members for moving the columnar drive shaft through the longitudinal aperture of the rotational drive mechanism in a second direction relative to the planar drive surface thereof opposite from the first direction.

13. The suction cup installation mechanism of claim 12 wherein the means of the columnar drive shaft for interacting with the spiral release drive members of the rotational drive mechanism further comprises a rigid release drive pin installed crosswise to the columnar drive shaft at a position between the installation drive pin and the means for connecting to a suction cup.

14. The suction cup installation mechanism of claim 7 wherein the housing further comprises a utilization mounting surface structured as a pattern of mounting holes spaced away from the housing planar drive surface a distance sufficient to admit the rotational drive mechanism therebetween.

US 6,666,420 B1

13

15. A suction cup holding device having a compact installation mechanism, the device comprising:

- a housing having a relatively wide and shallow concavity formed therein and forming a first opening on the surface thereof, an external reaction drive surface axially aligned with the concavity, and a second opening communicating between the concavity and the external reaction drive surface;
 - a plunger having a drive shaft coupled at one end to a suction cup having a resiliently deformable portion sized to cooperate with the housing concavity and an integral peripheral lip portion sized larger than the first opening, the resiliently deformable portion of the suction cup being installed substantially within the housing concavity with the peripheral lip portion projecting beyond the first opening thereof, and the plunger drive shaft being engaged with the second opening between the concavity and the reaction drive surface with a distal portion of the plunger drive shaft projecting external to the concavity and beyond the reaction drive surface;
 - a rotational drive member having a first drive surface structured to cooperate with the housing reaction drive surface and an annular installation drive surface inclined relative to the first drive surface and forming a substantially round central passage therethrough sized to admit the plunger drive shaft and rotate relative thereto;
- and means engaged between the distal portion of the plunger drive shaft and the annular installation drive surface for drawing the plunger drive shaft outwardly through the second opening in the housing when the

14

rotational drive member is rotated in a first direction relative to the external reaction drive surface.

16. The suction cup holding device of claim 15 wherein the first opening in the housing formed by the concavity further includes means for engaging a peripheral portion of the suction cup and position only fixing it during operation of the rotational drive member.

17. The suction cup of claim 15, further comprising means for retaining the plunger drive shaft in fixed rotational orientation relative to the housing during operation of the rotational drive member.

18. The suction cup of claim 15 wherein the rotational drive member further comprises an annular release drive surface longitudinally offset from the annular installation drive surface toward the first drive surface and relatively inclined thereto; and

further comprising means engaged between the distal portion of the plunger drive shaft and the annular release drive surface for driving the plunger drive shaft inwardly through the second opening in the housing when the rotational drive member is rotated in a second counter-direction relative to the housing reaction drive surface.

19. The suction cup of claim 15 wherein the rotational drive member further comprises means for securing the plunger drive shaft in fixed rotational orientation to the annular installation drive surface.

20. The suction cup of claim 15 wherein the annular installation drive surface further comprises a pair of annular installation drive surfaces diametrically opposed across a central passage.

* * * * *