

HARTMAN UNDERHILL & BRUBAKER LLP
 Kevin M. French, Esquire
 Attorney I.D. No. 47589
 Joshua D. Cohen, Esquire
 Attorney I.D. No. 51914 Attorneys for Plaintiff
 221 East Chestnut Street
 Lancaster, PA 17602
 (717) 299-7254/(717) 299-3160 (facsimile)

**IN THE UNITED STATES DISTRICT COURT
 FOR THE EASTERN DISTRICT OF PENNSYLVANIA**

THOMAS RÖPKE,	:	
	:	
Plaintiff,	:	Civil Action No. _____
	:	
v.	:	
	:	
AFFORDABLE TOOLS, LLC	:	
	:	
Defendant.	:	

COMPLAINT

The Parties

1. Plaintiff, THOMAS RÖPKE ("RÖPKE")
 is a German citizen, located and doing business at
 Holtenser Weg 27, 31832 Springe, Hanover, Germany.

2. Upon information and belief, Defendant,
 AFFORDABLE TOOLS, LLC ("CRAIG") is a Michigan corporation
 located and doing business at 85 La Voy Road, Erie,

Michigan, 48133, and operates interactive websites and does business under the names CRAIG'S AFFORDABLE TOOLS, and DRAGWAY TOOLS.

Jurisdiction and Venue

2. This action is for patent infringement arising under the patent laws of the United States, Title 35, of the United States Code, 35 U.S.C. §§ 1 et seq. This Court has original jurisdiction over the subject matter of this Complaint under 28 U.S.C. § 1338(a).

3. This Court has personal jurisdiction over CRAIG because CRAIG conducts business in this judicial district and in the Commonwealth of Pennsylvania, and has committed acts of patent infringement and/or contributed to or induced acts of patent infringement by others in this judicial district and elsewhere throughout the Commonwealth of Pennsylvania and in the United States.

4. The venue in this district is proper under 28 U.S.C. § 1391(b) and (c), and § 1400(b) because CRAIG is subject to personal jurisdiction in this district,

regularly conducts business in this district, and certain acts complained of herein occurred in this district.

Count 1 - Patent Infringement

6. RÖPKE is the owner of all right, title, and interest in and to U.S. Patent No. 5,488,849 ("the '849 Patent"), entitled "ROLLING AND FLANGING TOOL TO BEND BACK AND/OR WIDEN FENDER-WHEEL WELL EDGES". A copy of the '849 Patent is attached to this Complaint as Exhibit A.

7. The '849 Patent was issued by the United States Patent and Trademark Office on February 6, 1996. The '849 Patent remains valid and enforceable. RÖPKE has the sole and exclusive right to enforce his rights in the '849 Patent, and also has standing to sue and recover damages for infringement of the '849 Patent.

8. Upon information and belief, CRAIG makes, uses, offers to sell, and/or sells within the United States, and/or imports into the United States, products that infringe one or more claims of the '849 Patent, including, but not limited to, the manufacture, use, offer

for sale, sale and/or import into the United States, of a tool identified as a DRAGWAY TOOLS 6001 FENDER ROLLER LIP FLARING AND ROLLING TOOL, within the United States, the Commonwealth of Pennsylvania, and this judicial district.

9. Upon information and belief, CRAIG has directly infringed, contributorily infringed, and/or actively induced the infringement of at least Claims 1 and 16 of the '849 Patent.

10. CRAIG's unlawful acts of infringement of the '849 Patent will continue unless enjoined by this Court.

11. Upon information and belief, CRAIG's infringement of the '849 Patent is willful, intentional, and deliberate.

12. RÖPKE has been injured by the infringing acts of CRAIG and is entitled to recover damages adequate to compensate him for the infringement that has occurred.

13. RÖPKE is entitled to recover from CRAIG the damages sustained by RÖPKE as a result of CRAIG's wrongful acts in an amount subject to proof at trial.

14. Unless CRAIG is enjoined by this Court from continuing its infringement of the '849 Patent, RÖPKE will suffer additional irreparable harm and impairment of the value of his patent rights. Thus, RÖPKE is entitled to an injunction against further infringement.

Prayer for Relief

WHEREFORE, RÖPKE prays that this Court enter judgment in its favor and against CRAIG as follows:

- A. That CRAIG has infringed the '849 Patent;
- B. That CRAIG's infringement of the '849 Patent has been willful;
- C. That an injunction be entered

prohibiting CRAIG, and all those acting in concert or participating with CRAIG, from further acts of infringement of the '849 Patent;

D. That CRAIG be ordered to pay an award to RÖPKE of such damages as it can prove at trial against CRAIG sufficient to fully and adequately compensate it for all the acts of infringement that have occurred, said damages to be no less than a reasonable royalty;

E. A declaration that this is an exceptional case because of CRAIG's willful infringement of the '849 Patent, and an award to RÖPKE of treble damages pursuant to 35 U.S.C. § 284;

F. That CRAIG be ordered to pay RÖPKE's attorneys' fees pursuant to 35 U.S.C. § 285;

G. That CRAIG be ordered to pay prejudgment interest;

H. That CRAIG be ordered to pay all of RÖPKE's costs associated with this action;

I. That RÖPKE be granted such other and additional relief as the Court may deem just and proper.

Respectfully submitted,

HARTMAN UNDERHILL & BRUBAKER LLP

Date: _____

9/21/11

By: _____



Kevin M. French
Attorney I.D. #47589
Joshua D. Cohen
Attorney I.D. #51914
Attorneys for Plaintiff

Exhibit A



US005488849A

United States Patent [19]
Röpke

[11] **Patent Number:** 5,488,849
 [45] **Date of Patent:** Feb. 6, 1996

[54] **ROLLING AND FLANGING TOOL TO BEND BACK AND/OR WIDEN FENDER-WHEELWELL EDGES**

1,826,834	10/1931	Shaw	72/248
1,880,246	10/1932	Greiner	72/211
1,893,196	1/1933	Buck	72/248
2,274,032	2/1942	Blair	72/705
2,664,063	12/1953	Makruski	72/705

[75] **Inventor:** Thomas Röpke, Springe, Germany

FOREIGN PATENT DOCUMENTS

[73] **Assignee:** Thomas Röpke Werkzeugbau und Technischer Vertrieb, Springe, Germany

199024	8/1988	Japan	72/160
893304	12/1981	U.S.S.R.	72/160

[21] **Appl. No.:** 206,172

Primary Examiner—Daniel C. Crane
Attorney, Agent, or Firm—Shlesinger Arkwright & Garvey

[22] **Filed:** Mar. 7, 1994

[57] **ABSTRACT**

[51] **Int. Cl.⁶** B21D 19/00; B21D 53/88

The invention concerns a rolling and flanging tool to bend back and/or widen fender-wheelwell edges of motor vehicles. To carry out the bending back and/or widening of fender-wheelwell-edges in simpler and more uniform manner and without risk of damage to the enamel and sheet-metal, a flanging roll 46 to be pressed against the fenders is provided, which is connected to an affixing flange 4 to be affixed to the motor-vehicle axle, said roll being pivotable about said axle.

[52] **U.S. Cl.** 72/210; 72/211; 72/705

[58] **Field of Search** 72/210, 211, 215, 72/248, 705; 29/401.1

[56] **References Cited**

U.S. PATENT DOCUMENTS

1,739,488	12/1929	Thayer	72/705
1,775,968	9/1930	Nelson	72/705
1,813,012	7/1931	Asher	72/215

19 Claims, 2 Drawing Sheets

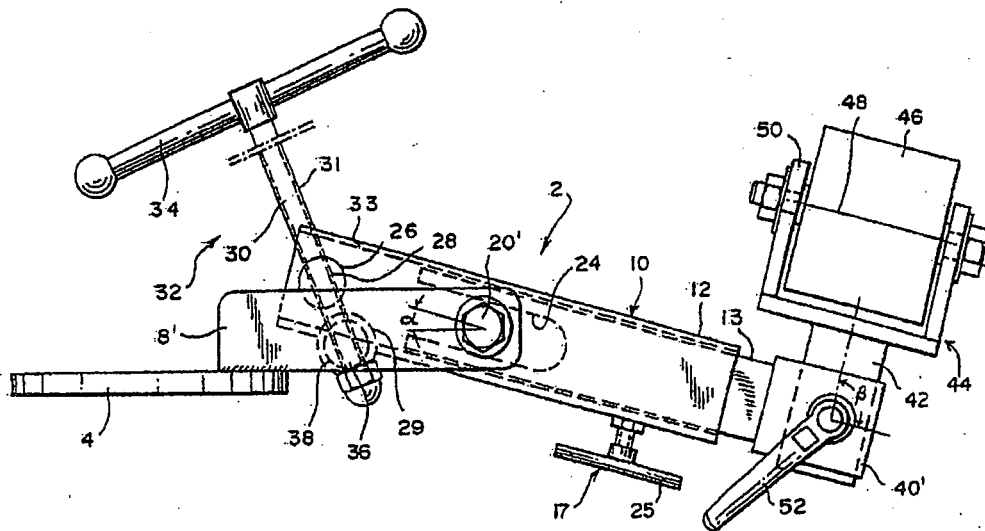



US005488849A

United States Patent [19]

[11] **Patent Number:** 5,488,849

Röpke

[45] **Date of Patent:** Feb. 6, 1996

[54] **ROLLING AND FLANGING TOOL TO BEND BACK AND/OR WIDEN FENDER-WHEEL WELL EDGES**

1,826,834	10/1931	Shaw	72/248
1,880,246	10/1932	Greiner	72/211
1,893,196	1/1933	Buck	72/248
2,274,032	2/1942	Blair	72/705
2,664,063	12/1953	Makruski	72/705

[75] **Inventor:** Thomas Röpke, Springe, Germany

FOREIGN PATENT DOCUMENTS

[73] **Assignee:** Thomas Röpke Werkzeugbau und Technischer Vertrieb, Springe, Germany

199024	8/1988	Japan	72/160
893304	12/1981	U.S.S.R.	72/160

[21] **Appl. No.:** 206,172

Primary Examiner—Daniel C. Crane
Attorney, Agent, or Firm—Shlesinger Arkwright & Garvey

[22] **Filed:** Mar. 7, 1994

[57] **ABSTRACT**

[51] **Int. Cl.⁶** B21D 19/00; B21D 53/88

The invention concerns a rolling and flanging tool to bend back and/or widen fender-wheelwell edges of motor vehicles. To carry out the bending back and/or widening of fender-wheelwell edges in simpler and more uniform manner and without risk of damage to the enamel and sheet-metal, a flanging roll 46 to be pressed against the fenders is provided, which is connected to an affixing flange 4 to be affixed to the motor-vehicle axle, said roll being pivotable about said axle.

[52] **U.S. Cl.** 72/210; 72/211; 72/705

[58] **Field of Search** 72/210, 211, 215, 72/248, 705; 29/401.1

[56] **References Cited**

U.S. PATENT DOCUMENTS

1,739,488	12/1929	Thayer	72/705
1,775,968	9/1930	Nelson	72/705
1,813,012	7/1931	Asher	72/215

19 Claims, 2 Drawing Sheets

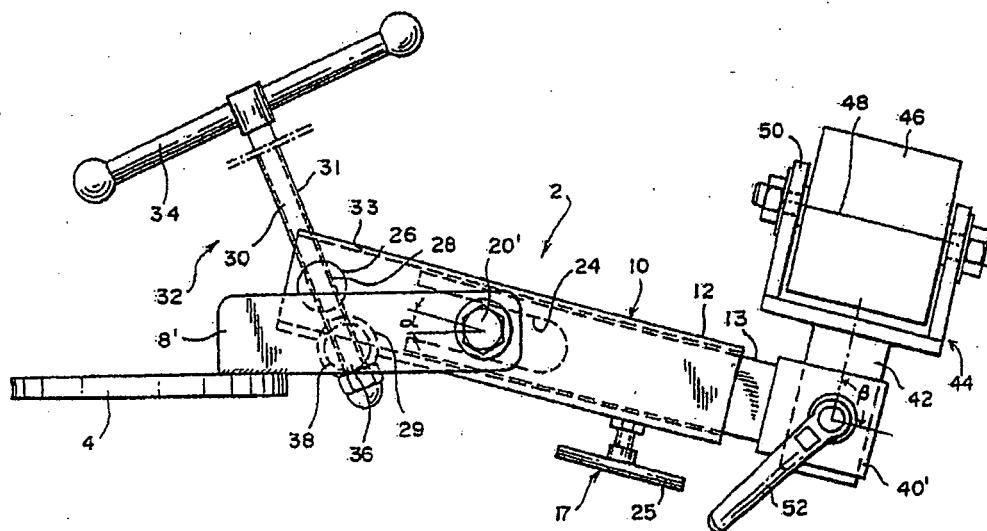

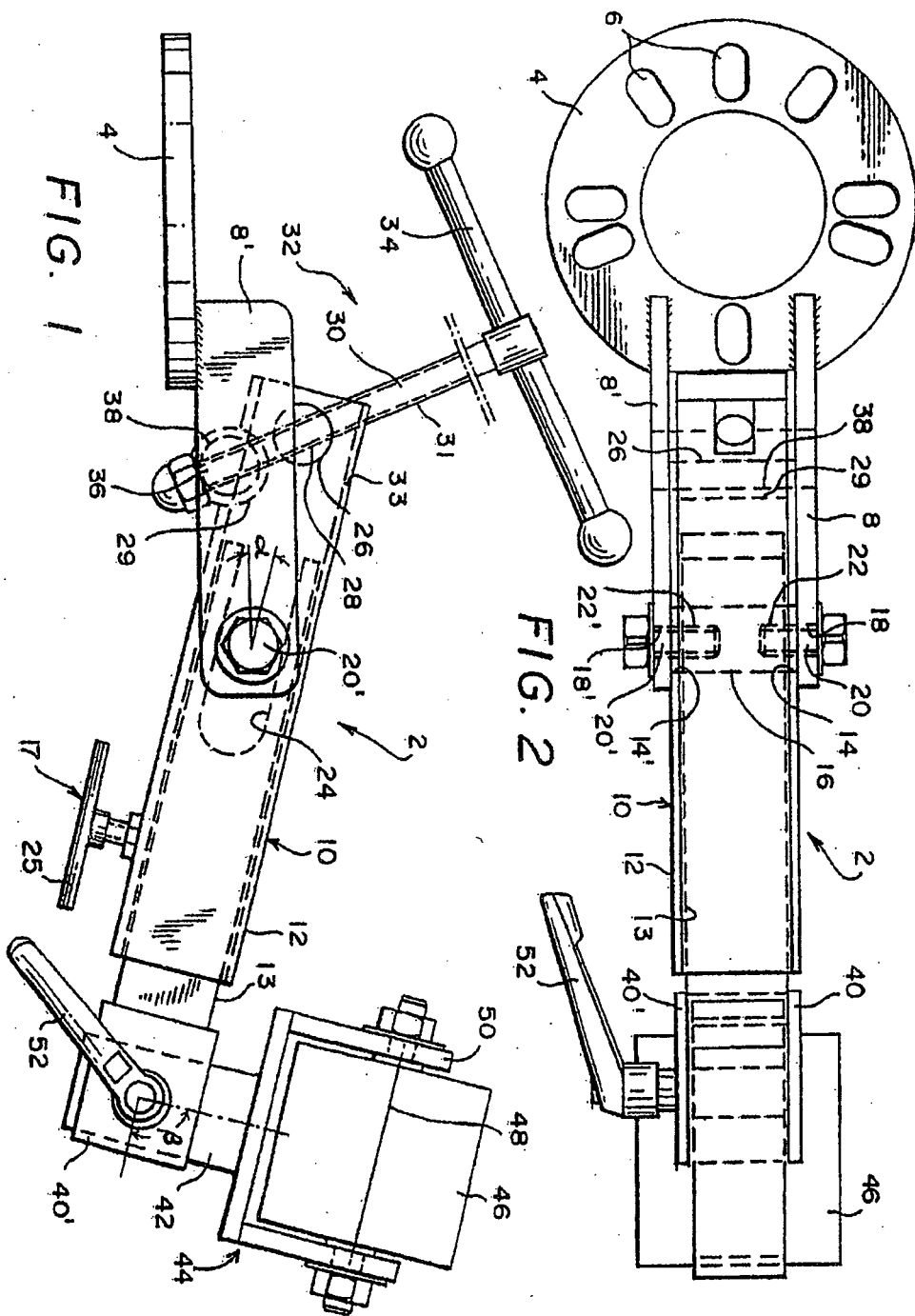

5,488,849

Sheet 1 of 2

Feb. 6, 1996

U.S. Patent

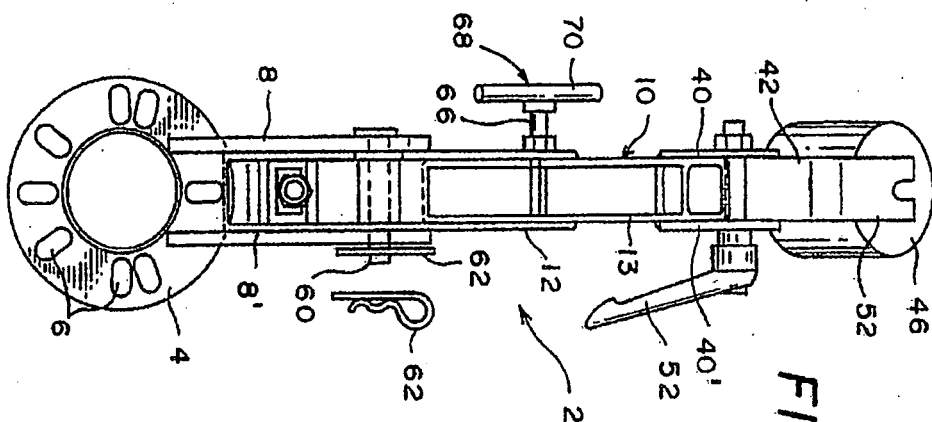

FIG. 4

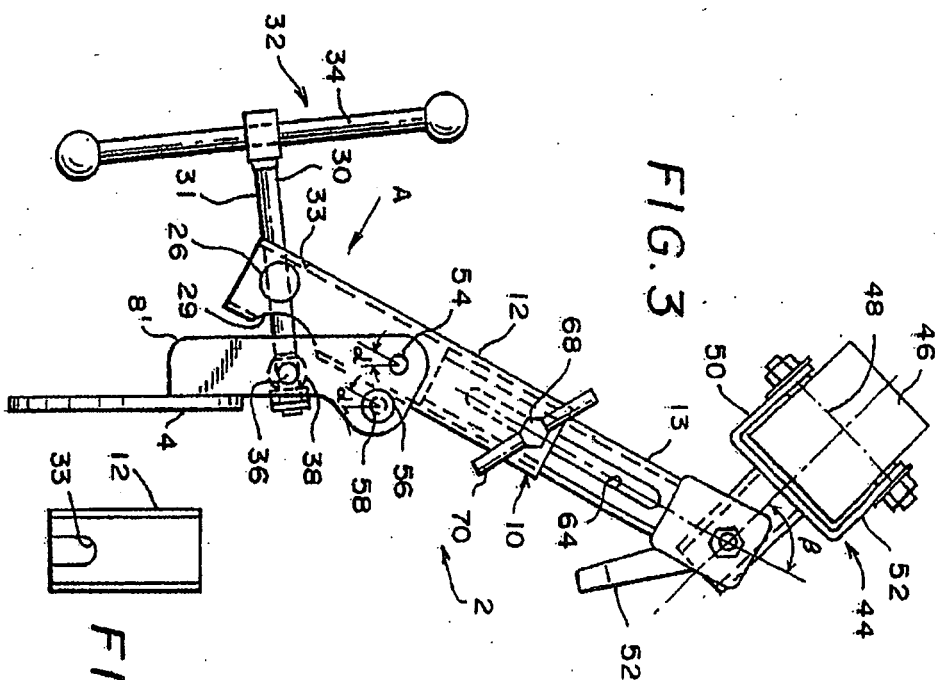

FIG. 3

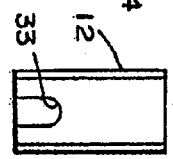

FIG. 5

5,488,849

1

ROLLING AND FLANGING TOOL TO BEND BACK AND/OR WIDEN FENDER-WHEEL WELL EDGES

BACKGROUND OF THE INVENTION

The invention concerns a rolling and flanging tool.

To install wide tires and the corresponding wheel rims, the fender-wheelwell edges must be bent back and/or widened. The tool used heretofore (FACHKENTNISSE KAROSERIE- UND FAHRZEUGBAU, Handwerk und Technik publishers, Hamburg, 1985, pp 35-6) using a flanging hammer or flanging tongs entailed tearing and damaging the enamel even when heating the fender and repainting was therefore required. The sheetmetal itself is dented in the process and loses rigidity. Furthermore the fender-work is fairly time-consuming and requires skilled labor.

The object of the present invention is to create a rolling and flanging tool of the initial cited kind allowing to bend back and/or widen fender-wheelwell edges in simpler and more uniform manner without the risk of damaging the enamel and sheetmetal of the fender-wheelwell edge.

This problem is solved by the design of the present invention.

The rolling and flanging tool of the invention allows simpler and more uniform rolling and/or flanging of fender-wheelwell edges. The tool is applicable to all kinds of motor vehicles. The pressure applied by the flanging roller used is adjustable and the roller merely needs being pivoted to bend back and/or widen fender wheelwell-edges which in known manner are previously heated. It was discovered in surprising manner that cracks in and damage to the enamel no longer arise when using the tool of the invention and consequently the repainting previously required is eliminated. The tool of the invention is handled in the simplest possible manner and also can be used by semi-skilled labor. The danger of denting the sheetmetal and of loss of rigidity is eliminated.

Advantageous and appropriate further developments of the solutions of the invention are stated in the detailed description of the preferred embodiment.

BRIEF DESCRIPTION OF THE DRAWINGS

The invention is elucidated below in relation to the attached drawing.

FIG. 1 is a sideview of a first embodiment mode of a rolling and flanging tool,

FIG. 2 is a topview of the tool of FIG. 1,

FIG. 3 is a sideview of a second embodiment mode of a rolling and flanging tool,

FIG. 4 is a topview of the tool of FIG. 3, and

FIG. 5 is an elevation A of the tool of FIG. 3.

DETAILED DESCRIPTION OF THE PREFERRED EMBODIMENT

In the Figures of the drawing, the same components are denoted by the same references.

The drawing shows a tool 2 to roll and flange the wheelwell-edges of motor-vehicle fenders.

The tool 2 comprises an annular affixing flange 4 with a UNIVERSAL array 6 of elongated slots for fastening to the axle of a motor vehicle after its wheel has been removed. Two rectangular, parallel planar legs 8, 8' welded to the

2

affixing flange 4 project from it and receive between them a pivotable, telescoping system of rectangular tubes 10.

The telescoping rectangular-tube system 10 comprises an outer rectangular-tube 12 receiving a displaceable inner rectangular tube 13.

In its end facing the affixing flange 4, the outer tube 12 receives a rotatably supported shaft 26 which is centrally traversed by a radial threaded borehole 28 receiving a threaded segment 31 of a threaded spindle 30 of a pulling device 32 with grip 34.

One end zone 36 of the threaded spindle 30 is mounted in freely rotatable manner in a shaft 38 rotatably mounted between the two legs 8, 8' of the affixing flange 4. The outer tube 12 of the telescoping rectangular-tube system 10 comprises at its underside an arcuate clearance 29 into which can be pivoted the shaft 38 of the legs 8, 8'. At its top side, the outer tube comprises a clearance 33 at its side near the flange (FIG. 5) into which can be pivoted the threaded spindle 30.

The angle α between the telescoping rectangular-tube system 10 and the legs 8, 8', ie the affixing flange 4, can be adjusted by rotating the threaded spindle 30.

At its end projecting out of the outer tube 12, the inner tube 13 of the telescoping rectangular-tube system 10 comprises two planar supports in the form of clamping jaws 40, 40' supporting between them the stem 42 of a forked bearing 44 for a plastic flanging roll 46 of which the shaft 48 rests in rotatable manner in the U-legs 50, 50' of the bearing 44. Using a tightening lever 52, the angle β between the flanging roll 46 and the telescoping rectangular-tube system 10 can be matched to the angle of the fender-wheelwell edge.

In the embodiment mode of FIGS. 1 and 2, the outer tube comprises a borehole 14, 14' located approximately centrally in each of the shorter sides of the rectangle and receiving a shaft 16. The free ends of the legs 8, 8' each comprise a borehole 18, 18' aligned with the boreholes 14, 14' and passing screws 20, 20' entering axially threaded boreholes 22, 22' of the shaft 16.

At its end located in the outer tube 12, the inner tube 13 comprises two laterally open slots 24 traversed by the shaft 16. The inner tube 13 is affixable by a tightening screw 17 fitted with a grip 25 into the outer tube 12.

In the embodiment mode of FIGS. 3 through 5, the outer rectangular tube 12 comprises a borehole 54 in the two small rectangle sides and a bearing 56 welded onto its underside, said bearing 56 comprising a borehole 58 which is parallel to the borehole 54. The assembly of the rectangular outer tube 12 takes place depending on the required range of adjustment in the borehole 54 or in the borehole 58 by means of a bolt 60 secured by a W-clip 62 (FIG. 4). The assembly into the borehole 54 corresponds to the design of FIGS. 1 and 2.

The inner tube 13 comprises a lateral elongated slot 64 through which the threaded shank 66 of a tightening screw 68 fitted with a grip 70 and mounted on an inside-threaded part 72 welded onto the outer tube 12 can be turned to come to rest against the opposite rectangular side of the inner tube 13 in order to clamp the inner tube into the outer tube.

The tool is operated as follows: Once the affixing flange 4 has been mounted to the axle, the inner tube 13 is moved in or out to such an extent that the flanging roller 46 is moved into the vicinity of the fender-wheelwell edge. Thereupon the slope of the flanging roller (angle β) is matched to the angle of the fender-wheelwell edge. By rotating the threaded spindle 30 and tightening the telescoping rectangular-tube system 10, the angle α between the telescoping

5,488,849

3

rectangular-tube system 10 and the legs 8, 8' is reduced to generate compression by the flanging roll on the fender-wheelwell edge. By pivoting the tool together with the motor-vehicle axle, the previously heated fender-wheelwell edge then is bent back and/or widened, said heating for instance being by a hot-air gun.

The embodiment mode of FIGS. 3-5 offers the following advantages relative to that of FIGS. 1 and 2: The range of adjustment of the tool is enlarged by the two boreholes 54, 58 and the elongated slot 64. When the set-up of the borehole 58 is used, the limitations set by the bolt 60 on the adjusting range of the telescoping tube system is eliminated. The tool is sturdier because the closed rectangular or box cross-sections are being used and the slots 24 of the embodiment mode of FIGS. 1 and 2 can be eliminated.

I claim:

1. A rolling and flanging tool for uniformly reforming a fender wheelwell comprising:

- a) an elongated body member having a working end and a securing end;
- b) an affixing flange extending from said securing end, said affixing flange configured to secure said first end of said tool to a vehicle axle for rotation therewith;
- c) a flanging roller extending from said working end, said flanging roller adapted to roll against a fender wheelwell and along an arcuate path as the vehicle axle is rotated; and
- d) adjustable fixing member, said fixing member configured to variably fix the position of said flanging roller relative to the vehicle axle and simultaneously compress said flanging roller against the fender wheelwell whereby rotation of the vehicle axle will roll said flanging roller against the fender wheelwell along a uniform arc and reform the same.

2. A rolling and flanging tool as in claim 1 and wherein:

- a) said elongated body member is an adjustable length telescopic tube;
- b) said telescopic tube including an exterior tube and an interior tube slidably received therein; and
- c) said interior tube includes said body member working end and said exterior tube includes said body member securing end.

3. A rolling and flanging tool as in claim 1 and wherein:

- a) said adjustable fixing member including pivot members for securing each of said flanging roller and said affixing flange to said body member.

4. A rolling and flanging tool as in claim 2 and wherein:

- a) said affixing flange including a pair of parallel leg members extending therefrom and having at least a portion of said telescopic tube positioned therebetween, said affixing flange is pivotally mounted to said telescopic tube about said leg members.

5. A rolling and flanging tool as in claim 4 and wherein:

- a) said adjustable fixing member including a borehole extending through said securing end of said telescopic tube and transverse thereto and a rotatable spindle member operational therewith, said spindle member threadedly received within said borehole and having one end thereof rotatably secured to said affixing flange leg members and extending therebetween whereby rotation of said spindle will selectively pivot said elongated body member relative to said affixing flange.

6. A rolling and flanging tool as in claim 4 and further comprising:

- a) bolt members for pivotally mounting each of said leg members to said elongated body member; and

4

- b) said interior tube including a pair of longitudinal slots extending therein, each of said slots adapted to receive a respective one of said bolt members as the length of said telescopic tube is adjusted.

7. A rolling and flanging tool as in claim 4 and further comprising:

- a) means for variably mounting said leg members to said telescopic tube.

8. A rolling and flanging tool as in claim 7 and wherein:

- a) said variable mounting means including at least two pairs of boreholes extending through said leg members, each of said at least two pairs of boreholes is adapted for pivotal mounting with one of at least two cooperating passageways associated with said exterior tube.

9. A rolling and flanging tool as in claim 8 and wherein:

- a) each of said at least two cooperating passageways is a shaft member extending between and interconnecting said leg members.

10. A rolling and flanging tool as in claim 9 and wherein:

- a) one of said at least two cooperating passageways includes a bearing member, said one of said at least two cooperating passageways is affixed to the exterior surface of said exterior tube; and
- b) the other of said at least two cooperating passageways passes through said elongated tube.

11. A rolling and flanging tool as in claim 1 and wherein:

- a) said adjustable fixing member including a clamping member extending from said body member working end for adjustably securing said flanging roller to said body member at a desired angle therebetween.

12. A rolling and flanging tool as in claim 11 and wherein:

- a) said flanging roller including a flanging roll rotatably mounted within a roller support frame member; and
- b) said roller support frame member including a stem portion extending transverse to the rotational axis of said flanging roll, said stem portion is secured within said clamping member.

13. A rolling and flanging tool as in claim 5 and further including:

- a) a spindle shaft member for rotatably securing said spindle member end to said leg members; and
- b) said elongated body member including a spindle shaft recess member to enable free movement of said spindle shaft member during rotation.

14. A rolling and flanging tool as in claim 2 and further comprising:

- a) locking member operatively associated with said exterior tube and said interior tube, said locking member configured to adjustably secure said exterior tube to said interior tube.

15. A rolling and flanging tool as in claim 14 and wherein:

- a) said locking member including a slot member extending along the longitudinal axis of said interior tube, said slot member configured to receive a locking screw member extending through said exterior tube.

16. A rolling and flanging tool for uniformly reforming a fender wheelwell comprising:

- a) an elongated body member having a working end and a securing end, said elongated body member including a length adjustable telescopic tube comprising an exterior tube and an interior tube slidably received therein, said interior tube includes said working end and said exterior tube includes said securing end;

- b) an affixing flange extending from said securing end, said affixing flange adapted to secure said first end of said tool to a vehicle axle for rotation therewith;

5,488,849

5

- c) a flanging roller extending from said working end, said flanging roller positionable against a fender wheelwell for reforming the same;
 - d) an adjustable clamping member extending from said body member working end for adjustably securing said flanging roller to said body member at a desired angle therebetween; and
 - e) means for variably fixing said flanging roller relative to the vehicle axle and simultaneously compressing said flanging roller against the fender to be reformed whereby rotation of the vehicle axle will roll said flanging roller along the vehicle fender in a continuous and uniform arc and reform the same.
17. A rolling and flanging tool as in claim 16 and wherein:
- a) said flanging roller including a flanging roll rotatably mounted within a support frame member; and
 - b) said support frame member including a stem portion extending transverse to the rotational axis of said flanging roll, said stem portion is secured within said adjustable clamping member.

6

18. A rolling and flanging tool as in claim 16 and wherein:
- a) said affixing flange including a pair of parallel leg members extending therefrom and having at least a portion of said elongated body member extending therebetween, said affixing flange is pivotally mounted to said elongated body member about said leg members.
19. A rolling and flanging tool as in claim 18 and wherein:
- a) said variably fixing means including a borehole extending through said elongated body member securing end and transverse thereto a rotatable spindle member operational therewith, said spindle member threadedly received within said borehole and having one end thereof rotatably secured to said affixing flange leg members and extending therebetween whereby rotation of said spindle will selectively pivot said elongated body member relative to said affixing flange.

* * * * *

Exhibit A