

ORIGINAL

1  
2  
3  
4  
5  
6  
7  
8  
9  
10  
11  
12  
13  
14  
15  
16  
17  
18  
19  
20  
21  
22  
23  
24  
25  
26  
27  
28

Craig S. Summers (State Bar No. 108688)  
craig.summers@kmob.com  
David G. Jankowski (State Bar No. 205634)  
david.jankowski@kmob.com  
KNOBBE, MARTENS, OLSON & BEAR, LLP  
2040 Main Street  
Fourteenth Floor  
Irvine, CA 92614  
Phone: (949) 760-0404  
Facsimile: (949) 760-9502

Attorneys for Plaintiffs,  
WAVE LOCH, INC. and LIGHT WAVE, LTD.

IN THE UNITED STATES DISTRICT COURT

FOR THE SOUTHERN DISTRICT OF CALIFORNIA

WAVE LOCH, INC., a California corporation,  
and LIGHT WAVE, LTD., a Utah limited  
partnership,

Plaintiffs,

v.

AMERICAN WAVE MACHINES, INC., a  
California corporation,

Defendant.

Civil Action No.

COMPLAINT FOR PATENT  
INFRINGEMENT

DEMAND FOR JURY TRIAL

08 CV 0928 W WMC

BY: 

FILED  
08 MAY 23 PM 4:18  
CLERK U.S. DISTRICT COURT  
SOUTHERN DISTRICT OF CALIFORNIA

DEPOSIT  
FAXED

1 For its complaint against Defendant American Wave Machines, Inc., Plaintiffs Wave  
2 Loch, Inc. and Light Wave, Ltd. allege as follows

3 **PARTIES**

4 1. Plaintiff Wave Loch, Inc. ("Wave Loch") is a California corporation having its  
5 principal place of business at 210 Westbourne Street, La Jolla, California 92037.

6 2. Plaintiff Light Wave, Ltd. ("Light Wave") is a Utah limited partnership having  
7 its principal place of business at 150 N. Center Street, Reno, Nevada 89501.

8 3. Upon information and belief, Defendant American Wave Machines, Inc.  
9 ("AWM") is a California corporation having its principal place of business at 615 Marvista  
10 Drive, Solana Beach, California 92075.

11 **JURISDICTION AND VENUE**

12 4. This is an action for patent infringement arising under the United States Patent  
13 Laws, 35 U.S.C. § 101 *et seq.*

14 5. This Court has subject matter jurisdiction pursuant to 28 U.S.C. §§ 1331 and  
15 1338(a).

16 6. Upon information and belief, AWM conducts business throughout the United  
17 States, including in this Judicial District, and has committed the acts complained of in this  
18 Judicial District and elsewhere.

19 7. Venue lies in this judicial district under 28 U.S.C. §§ 1391(b) and (c) and  
20 1400(b).

21 **FIRST CLAIM FOR RELIEF**

22 **INFRINGEMENT OF U.S. PATENT NO. 5,236,280**

23 8. Plaintiffs incorporate by reference and reallege each of the allegations set forth  
24 in Paragraphs 1-7 above.

25 9. On August 17, 1993, U.S. Patent No. 5,236,280 ("the '280 Patent"), entitled  
26 "Method And Apparatus For Improving Sheet Flow Water Rides," was duly and legally  
27 issued by the United States Patent and Trademark Office. Light Wave is the owner of all

28 ///

1 right and title, both legal and equitable, to the '280 Patent. Wave Loch is the exclusive  
2 licensee of the '280 patent. A copy of the '280 Patent is attached hereto as Exhibit 1.

3 10. AWM has infringed the '280 Patent under 35 U.S.C. §271 through its  
4 manufacture, use, sale, and/or offer for sale of amusement water rides, including the  
5 SurfStream water ride.

6 11. AWM's acts of infringement have caused damage to Plaintiffs in an amount to  
7 be determined at trial.

8 12. AWM's infringement of the '280 Patent is causing irreparable harm to  
9 Plaintiffs, for which there is no adequate remedy at law. AWM's infringement will continue,  
10 and will continue to cause irreparable harm to Plaintiffs, unless AWM's infringement is  
11 enjoined by this Court.

12 13. Plaintiffs are informed and believe that AWM's infringement of the '280  
13 Patent was and is willful and deliberate, entitling Plaintiffs to enhanced damages under 35  
14 U.S.C. § 284 and attorneys' fees and non-taxable costs under 35 U.S.C. § 285.

15 **SECOND CLAIM FOR RELIEF**

16 **INFRINGEMENT OF U.S. PATENT NO. 5,393,170**

17 14. Plaintiffs incorporate by reference and reallege each of the allegations set forth  
18 in Paragraphs 1-7 above.

19 15. On February 28, 1995, U.S. Patent No. 5,393,170 ("the '170 Patent"), entitled  
20 "Method And Apparatus For Improving Sheet Flow Water Rides," was duly and legally  
21 issued by the United States Patent and Trademark Office. Light Wave is the owner of all  
22 right and title, both legal and equitable, to the '170 Patent. Wave Loch is the exclusive  
23 licensee of the '170 patent. A copy of the '170 Patent is attached hereto as Exhibit 2.

24 16. AWM has infringed the '170 Patent under 35 U.S.C. §271 through its  
25 manufacture, use, sale, and/or offer for sale of amusement water rides, including the  
26 SurfStream water ride.

27 17. AWM's acts of infringement have caused damage to Plaintiffs in an amount to  
28 be determined at trial.

1 18. AWM's infringement of the '170 Patent is causing irreparable harm to  
2 Plaintiffs, for which there is no adequate remedy at law. AWM's infringement will continue,  
3 and will continue to cause irreparable harm to Plaintiffs, unless AWM's infringement is  
4 enjoined by this Court.

5 19. Plaintiffs are informed and believe that AWM's infringement of the '170  
6 Patent was and is willful and deliberate, entitling Plaintiffs to enhanced damages under 35  
7 U.S.C. § 284 and attorneys' fees and non-taxable costs under 35 U.S.C. § 285.

8 **THIRD CLAIM FOR RELIEF**

9 **INFRINGEMENT OF U.S. PATENT NO. 5,564,859**

10 20. Plaintiffs incorporate by reference and reallege each of the allegations set forth  
11 in Paragraphs 1-7 above.

12 21. On October 15, 1996, U.S. Patent No. 5,564,859 ("the '859 Patent"), entitled  
13 "Method And Apparatus For Improving Sheet Flow Water Rides," was duly and legally  
14 issued by the United States Patent and Trademark Office. Light Wave is the owner of all  
15 right and title, both legal and equitable, to the '859 Patent. Wave Loch is the exclusive  
16 licensee of the '859 patent. A copy of the '859 Patent is attached hereto as Exhibit 3.

17 22. AWM has infringed the '859 Patent under 35 U.S.C. §271 through its  
18 manufacture, use, sale, and/or offer for sale of amusement water rides, including the  
19 SurfStream water ride.

20 23. AWM's acts of infringement have caused damage to Plaintiffs in an amount to  
21 be determined at trial.

22 24. AWM's infringement of the '859 Patent is causing irreparable harm to  
23 Plaintiffs, for which there is no adequate remedy at law. AWM's infringement will continue,  
24 and will continue to cause irreparable harm to Plaintiffs, unless AWM's infringement is  
25 enjoined by this Court.

26 25. Plaintiffs are informed and believe that AWM's infringement of the '859  
27 Patent was and is willful and deliberate, entitling Plaintiffs to enhanced damages under 35  
28 U.S.C. § 284 and attorneys' fees and non-taxable costs under 35 U.S.C. § 285.

**PRAYER FOR RELIEF**

WHEREFORE, Plaintiffs pray for judgment in their favor and seek relief as follows:

A. A judgment that AWM has infringed U.S. Patent No. 5,236,280, U.S. Patent No. 5,393,170, and U.S. Patent No. 5,564,859;

B. Preliminary and permanent injunctions against further infringement of U.S. Patent No. 5,236,280, U.S. Patent No. 5,393,170, and U.S. Patent No. 5,564,859 by AWM and all others in active concert or participation with AWM;

C. An award of damages for AWM's infringement of U.S. Patent No. 5,236,280, U.S. Patent No. 5,393,170, and U.S. Patent No. 5,564,859;

D. A trebling of the award of damages under 35 U.S.C. § 284, or such other enhancement of the award of damages that the Court deems appropriate;

E. A declaration that AWM's infringement of U.S. Patent No. 5,236,280, U.S. Patent No. 5,393,170, and U.S. Patent No. 5,564,859 was and is willful, and that this is an exceptional case under 35 U.S.C. § 285;

F. An award of attorneys' fees and non-taxable costs under 35 U.S.C. § 285 on account of AWM's willful infringement;

G. An award of taxable costs; and

H. Such other and further relief as this Court may deem just and proper.

KNOBBE, MARTENS, OLSON & BEAR, LLP

Dated: 5/23/08

By: 

Craig S. Summers  
David G. Jankowski  
Attorneys for Plaintiffs,  
WAVE LOCH, INC. and LIGHT WAVE, LTD.

1  
2  
3  
4  
5  
6  
7  
8  
9  
10  
11  
12  
13  
14  
15  
16  
17  
18  
19  
20  
21  
22  
23  
24  
25  
26  
27  
28

**DEMAND FOR TRIAL BY JURY**

Plaintiffs Wave Loch, Inc. and Light Wave, Ltd. hereby demand a trial by jury on all issues so triable in the above-captioned action.

KNOBBE, MARTENS, OLSON & BEAR, LLP

Dated: 5/23/08 By:   
Craig S. Summers  
David G. Jankowski  
Attorneys for Plaintiffs,  
WAVE LOCH, INC. and LIGHT WAVE, LTD.

LOCHTL.120L  
5399954\_1  
052008



US005236280A

**United States Patent** [19]

[11] **Patent Number:** 5,236,280

**Lochtefeld**

[45] **Date of Patent:** Aug. 17, 1993

- [54] **METHOD AND APPARATUS FOR IMPROVING SHEET FLOW WATER RIDES**
- [75] **Inventor:** Thomas J. Lochtefeld, La Jolla, Calif.
- [73] **Assignee:** Blade Loch, Inc., La Jolla, Calif.
- [21] **Appl. No.:** 577,741
- [22] **Filed:** Sep. 4, 1990

- 1300144 6/1962 France
- 1539959 8/1968 France
- 0041392 3/1977 Japan
- 52-41392 3/1977 Japan
- WO8304375 12/1983 PCT Int'l Appl.
- WP9006790 6/1990 PCT Int'l Appl.
- 212138 4/1968 U.S.S.R.
- 953075 8/1982 U.S.S.R.
- 1090262 2/1965 United Kingdom
- 1118083 3/1966 United Kingdom
- 1159269 11/1967 United Kingdom

**Related U.S. Application Data**

- [63] Continuation-in-part of Ser. No. 286,964, Dec. 19, 1988, Pat. No. 4,954,014, which is a continuation-in-part of Ser. No. 54,521, May 27, 1987, Pat. No. 4,792,260.
- [51] **Int. Cl.:** A63B 69/00
- [52] **U.S. Cl.:** 405/79; 405/52; 472/13
- [58] **Field of Search:** 405/79, 52, 303, 80; 73/148; 366/278; 4/491; 472/13

**OTHER PUBLICATIONS**

- Fauvelle/Blocquel, *Brevet D'Invention*, Sep. 19, 1933.
- Hornung, H. G. and Killen, P. "A Stationary Oblique Breaking Wave for Laboratory Testing of Surfboards," *Journal of Fluid Mechanics* (1976), vol. 78, Part 3, pp. 459-484.
- Killen, P. D., "Model Studies of a Wave Riding Facility," 7th Australasian Hydraulics and Fluid Mechanics Conference, Brisbane (1980).
- Killen, P. D. and Stalker, R. J. "A Facility for Wave Riding Research," Eighth Australasian Fluid Mechanics Conference, University of Newcastle, N.S.W. (1983).

[56] **References Cited**

**U.S. PATENT DOCUMENTS**

- 490,484 1/1893 Mackaye
- 799,708 9/1905 Boyce
- 1,655,498 1/1928 Fisch
- 1,701,842 2/1929 Fisch
- 1,871,215 8/1932 Keller
- 1,884,075 10/1932 Meyers
- 2,815,951 12/1957 Baldanza
- 3,005,207 10/1961 Matrai
- 3,038,760 6/1962 Crooke
- 3,085,404 4/1963 Smith
- 3,473,334 10/1969 Dexter
- 3,477,233 11/1969 Anderson
- 3,478,444 11/1969 Presnell
- 3,562,823 2/1971 Koster
- 3,598,402 8/1971 Frenzl

(List continued on next page.)

**FOREIGN PATENT DOCUMENTS**

- 159793 8/1903 Fed. Rep. of Germany
- 373684 7/1932 Fed. Rep. of Germany
- 2222594 5/1972 Fed. Rep. of Germany
- 2714223 10/1978 Fed. Rep. of Germany
- 1019527 10/1952 France

*Primary Examiner*—Dennis L. Taylor

[57] **ABSTRACT**

An amusement apparatus for water sports activities wherein a flowing body of water is provided. The water moves across an inclined, declined or horizontal riding surface upon which the velocity, volume and gravitational dynamics of the flowing body of water is such that a rider may perform water skimming/simulated surfing maneuvers thereon. Composite structures with horizontal and inclined surfaces and varying flow velocity over time across specifically shaped structures permit water skimming/simulated surfing maneuvers on unbroken, spilling or tunnel type wave forms. Asymmetry in the downstream ridge line of an inclined surface allows spilling type wave formations as well as facilitating the removal of a transient surge. A novel fluid "half-pipe" waveform is also introduced.

**31 Claims, 19 Drawing Sheets**

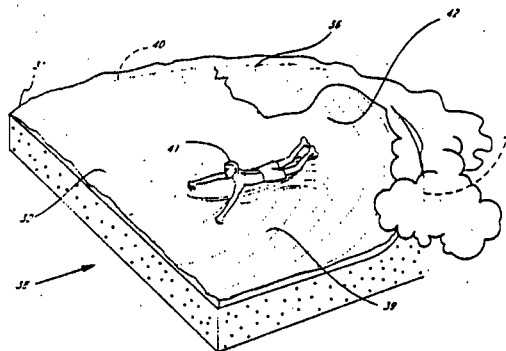

5,236,280

Page 2

---

U.S. PATENT DOCUMENTS

3,789,612	2/1974	Richard et al.	4,276,664	7/1981	Baker .
3,802,697	4/1974	LeMeaute .	4,522,535	6/1985	Bastenhof .
3,851,476	12/1974	Edwards .	4,538,719	9/1985	Schuster .
3,913,332	10/1975	Forsman .	4,564,190	1/1986	Frenzl .
3,981,612	9/1976	Bunger et al.	4,662,781	5/1987	Tinkler .
4,201,496	5/1980	Anderson .	4,790,685	12/1988	Scott et al. .
			4,792,260	12/1988	Sauerbier ..... 405/79
			4,905,987	3/1990	Frenzl .
			4,954,014	9/1990	Sauerbier et al. .



U.S. Patent

Aug. 17, 1993

Sheet 1 of 19

5,236,280

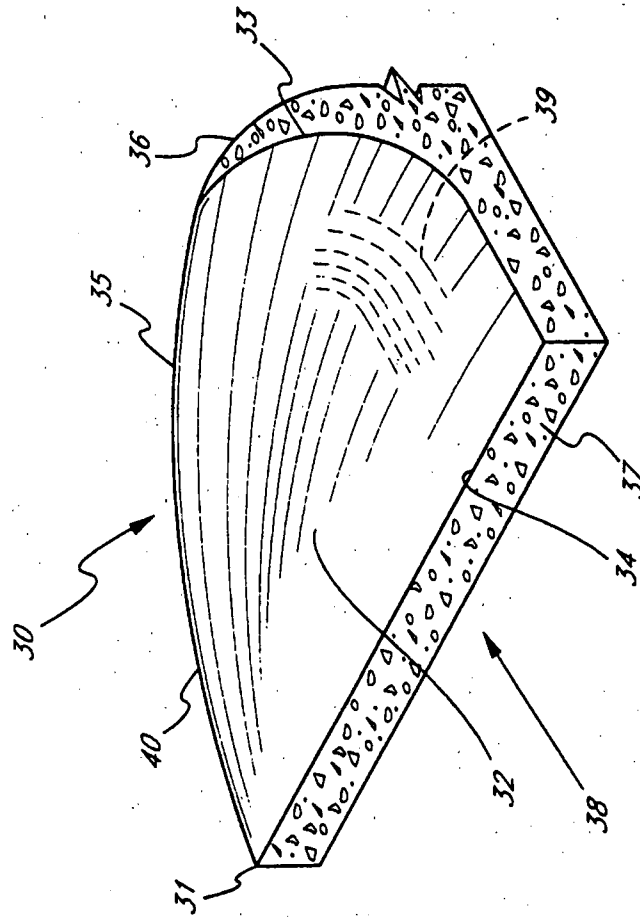

FIG. 1

U.S. Patent

Aug. 17, 1993

Sheet 2 of 19

5,236,280

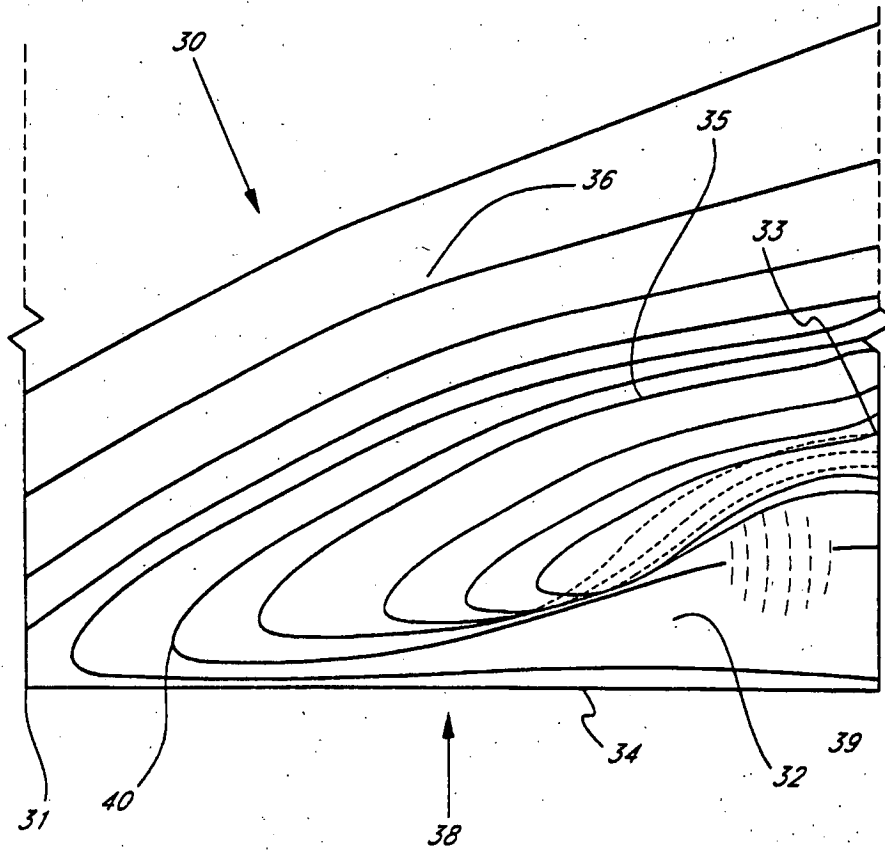

FIG. 2

U.S. Patent

Aug. 17, 1993

Sheet 3 of 19

5,236,280

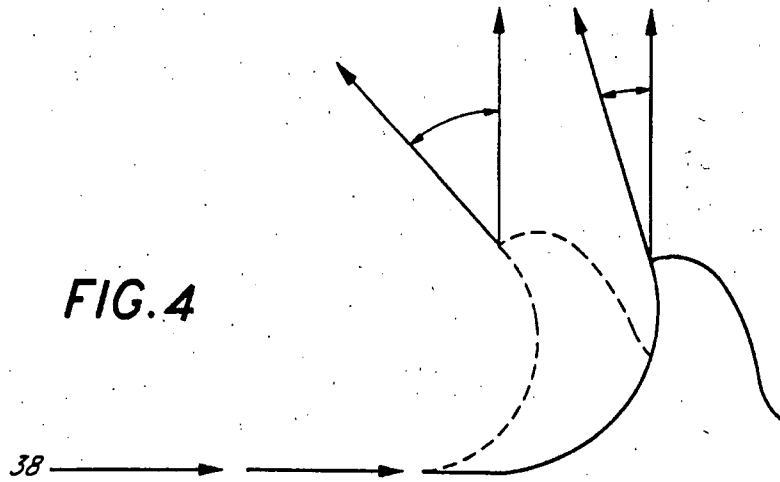
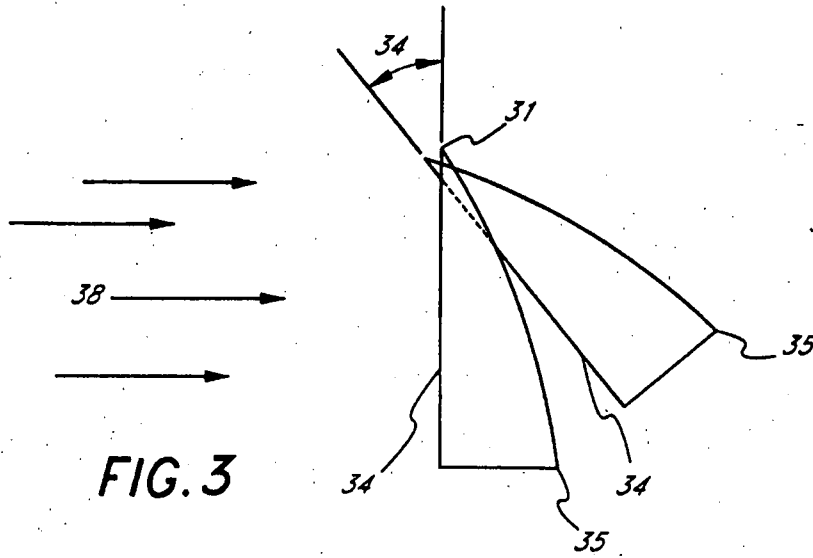

U.S. Patent

Aug. 17, 1993

Sheet 4 of 19

5,236,280

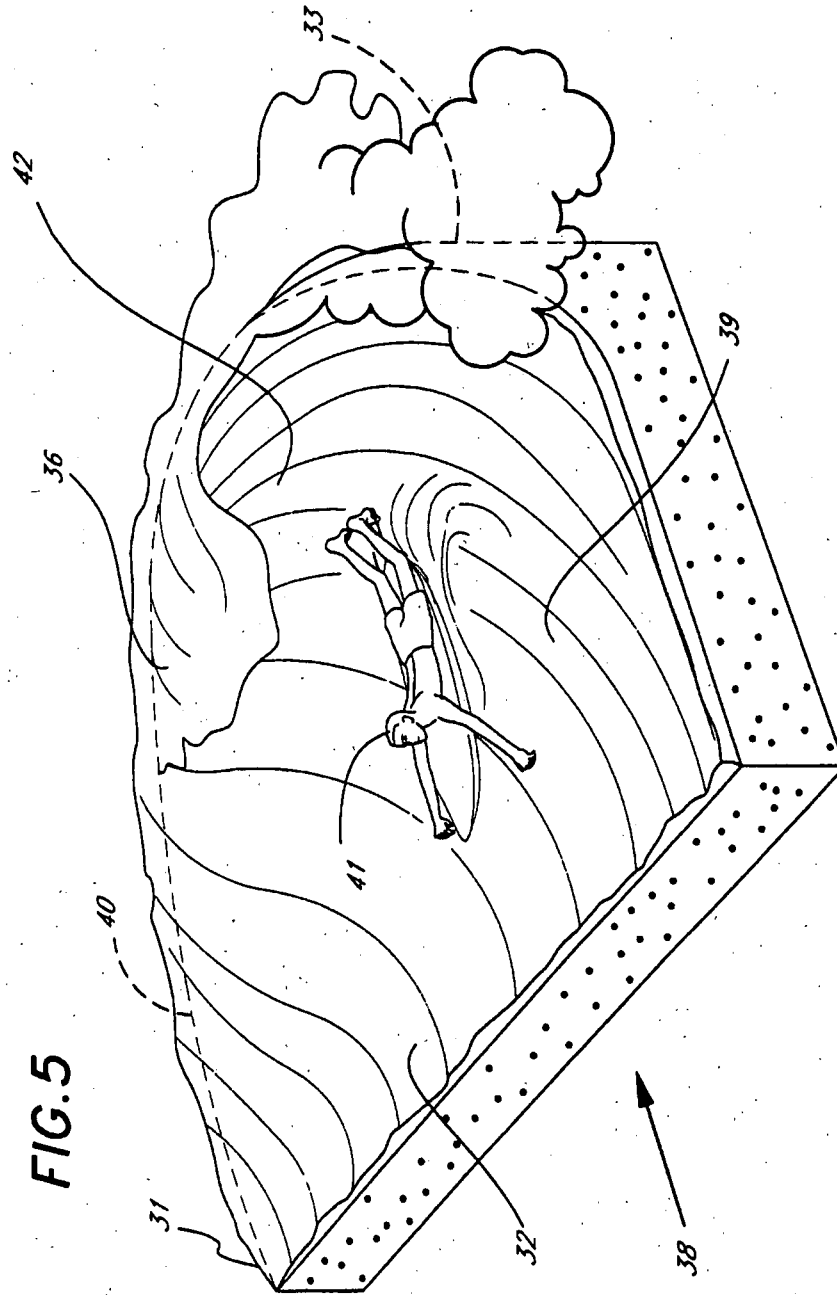

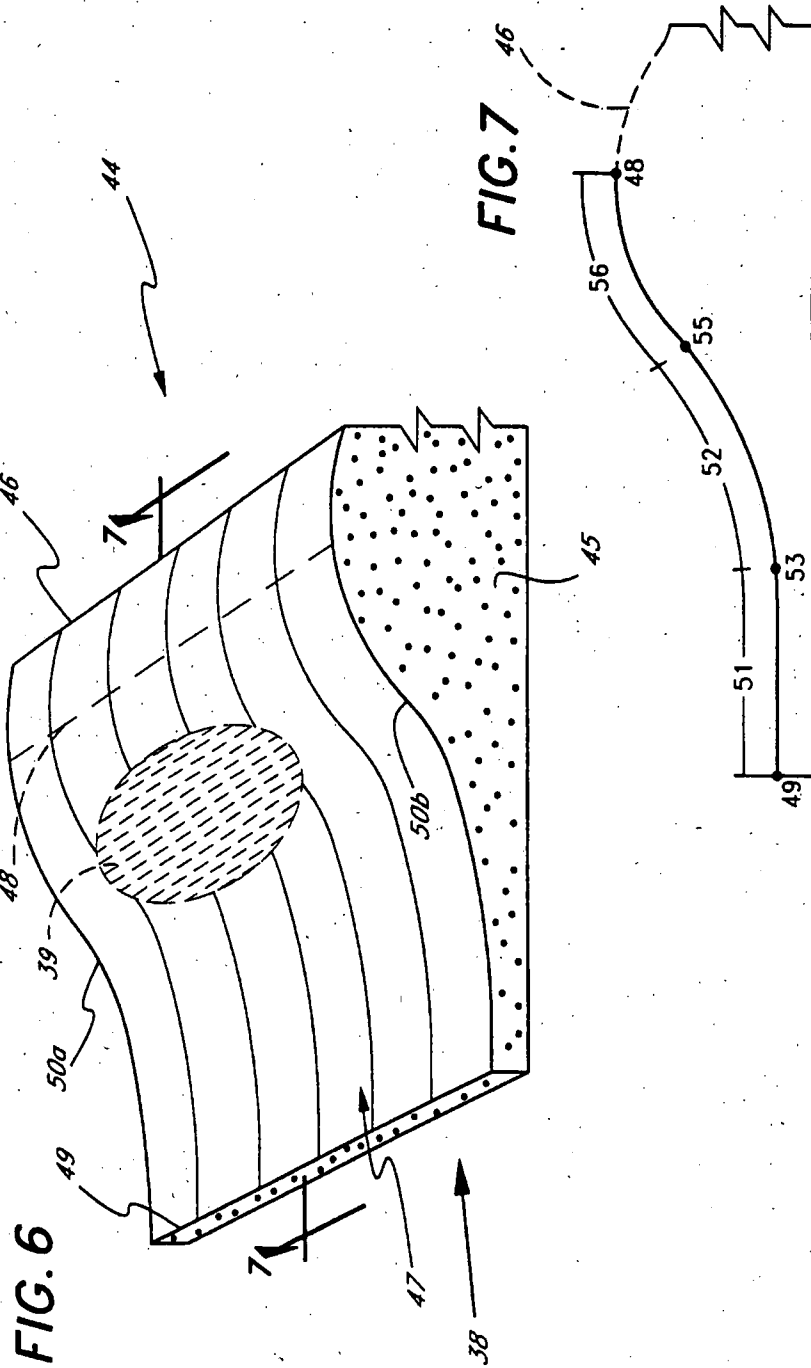

U.S. Patent

Aug. 17, 1993

Sheet 6 of 19

5,236,280

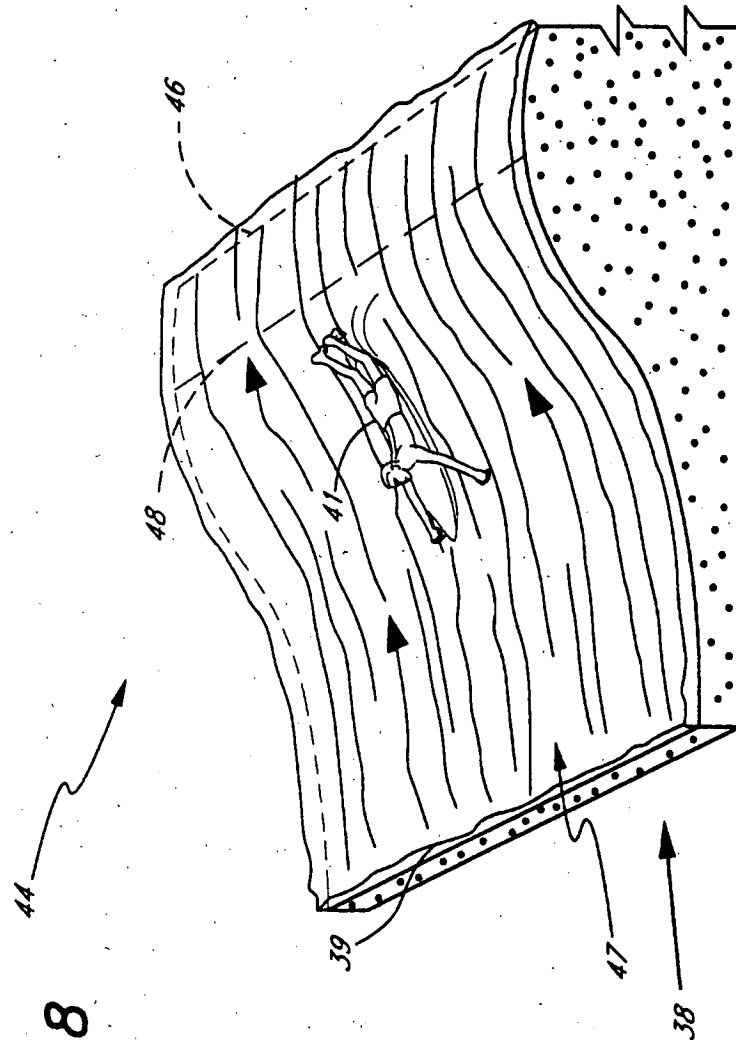

FIG. 8

U.S. Patent

Aug. 17, 1993

Sheet 7 of 19

5,236,280

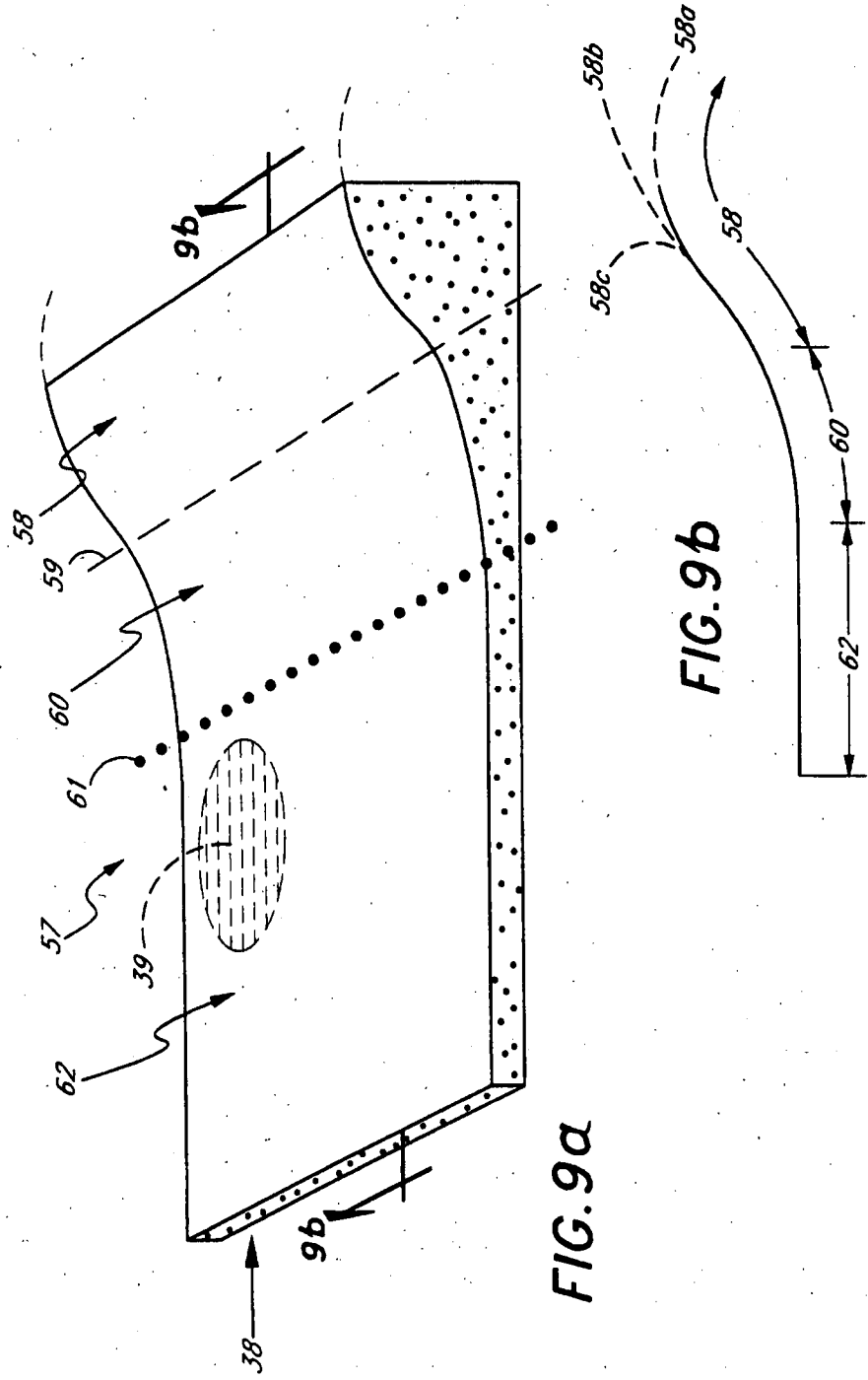

FIG. 9a

FIG. 9b

U.S. Patent

Aug. 17, 1993

Sheet 8 of 19

5,236,280

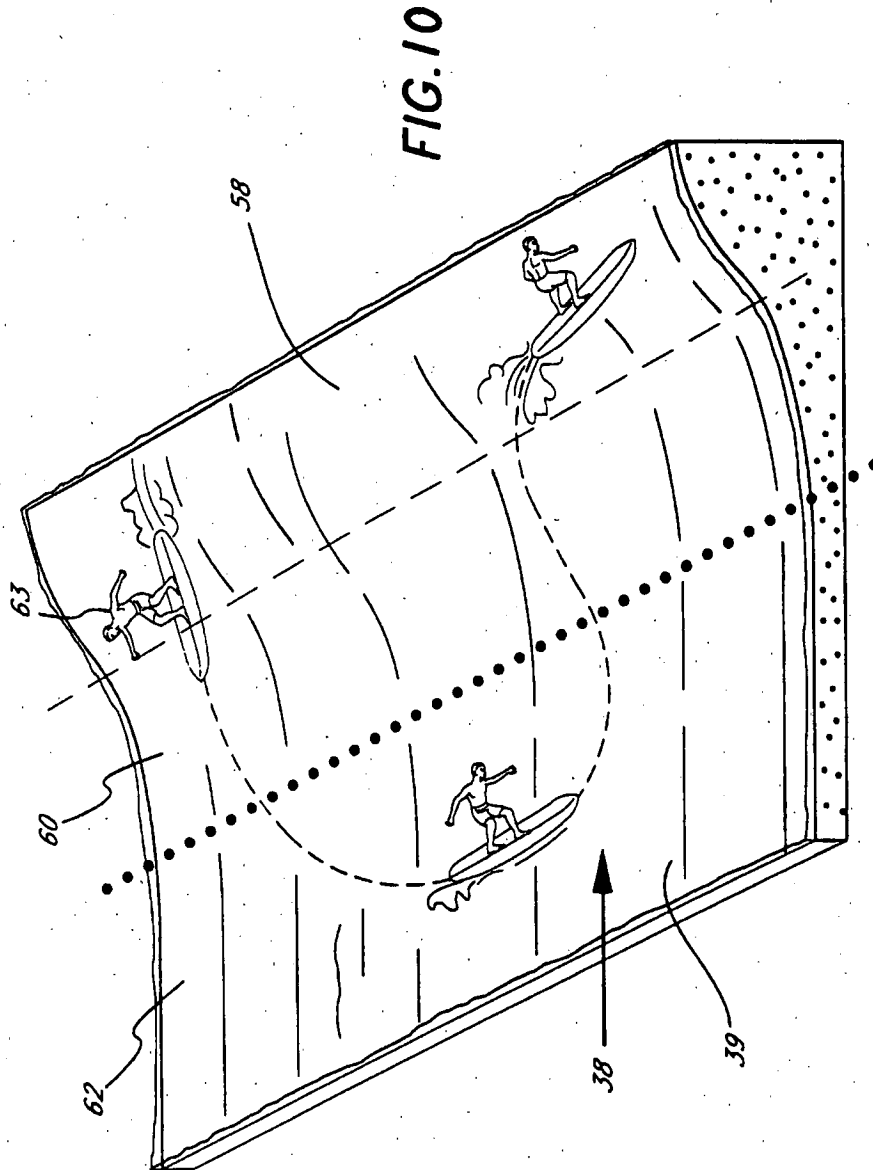



U.S. Patent

Aug. 17, 1993

Sheet 9 of 19

5,236,280

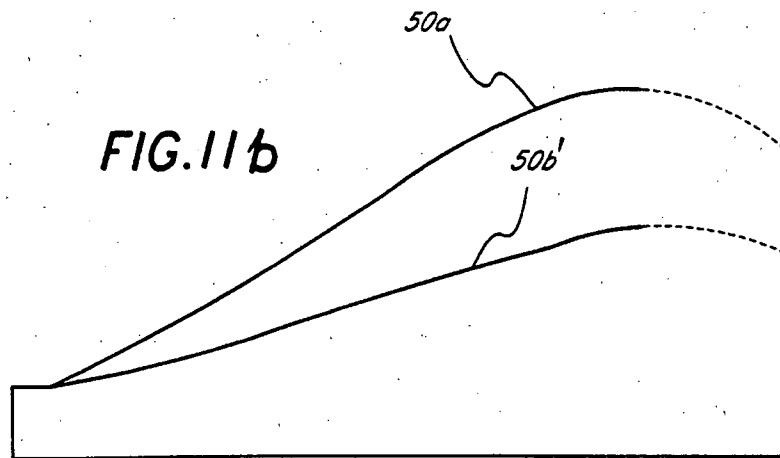
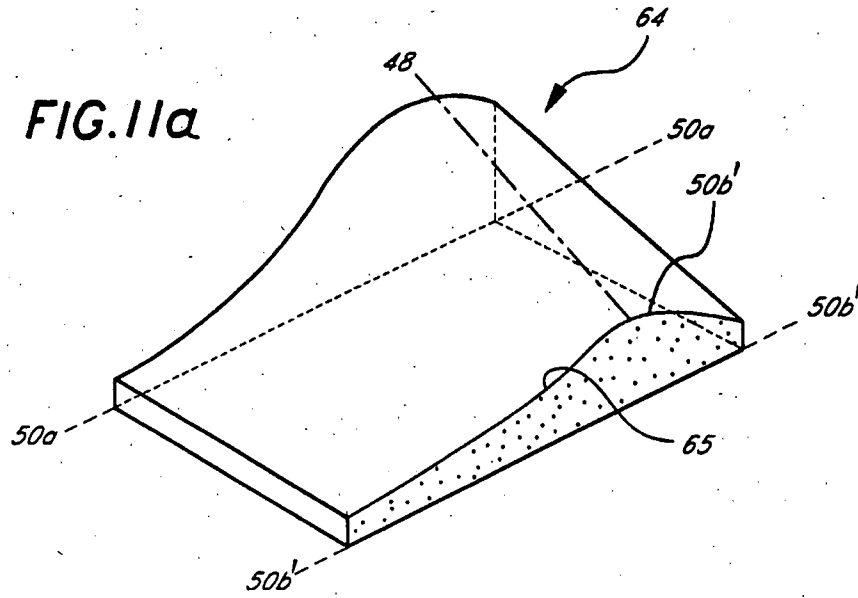

U.S. Patent

Aug. 17, 1993

Sheet 10 of 19

5,236,280

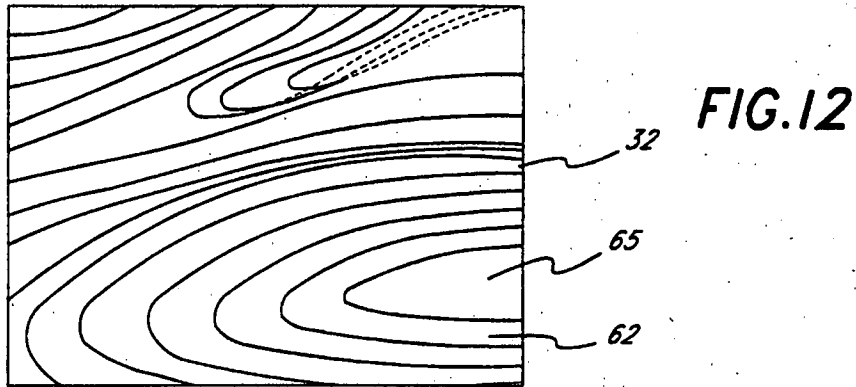

FIG. 14a

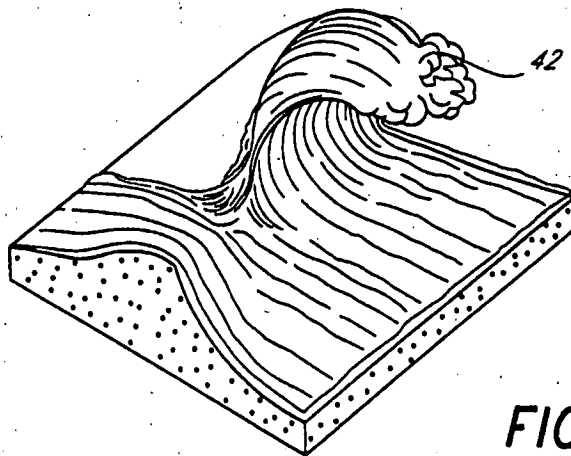
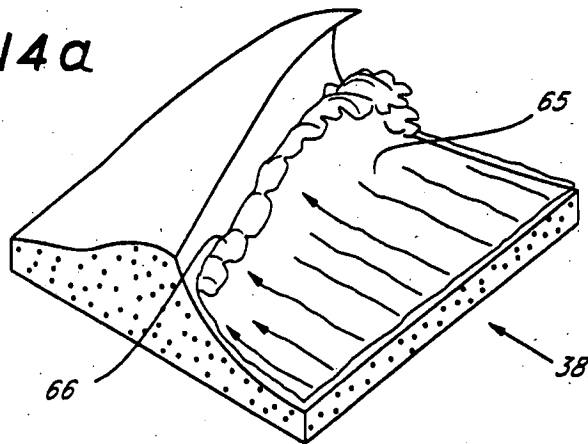

FIG. 14b

U.S. Patent

Aug. 17, 1993

Sheet 11 of 19

5,236,280

FIG. 13a

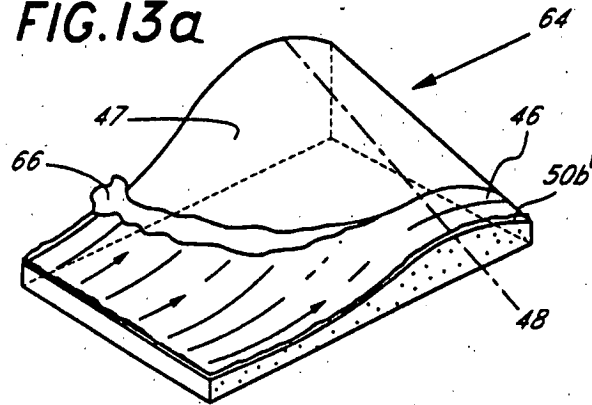

FIG. 13b

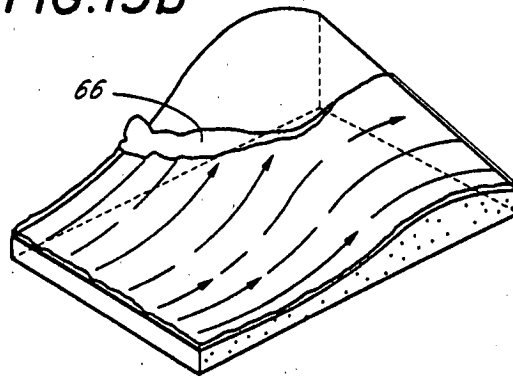
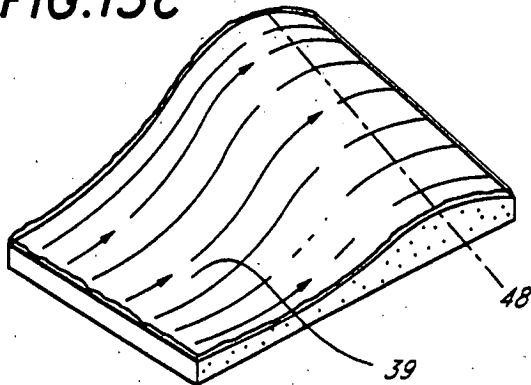

FIG. 13c



U.S. Patent

Aug. 17, 1993

Sheet 12 of 19

5,236,280

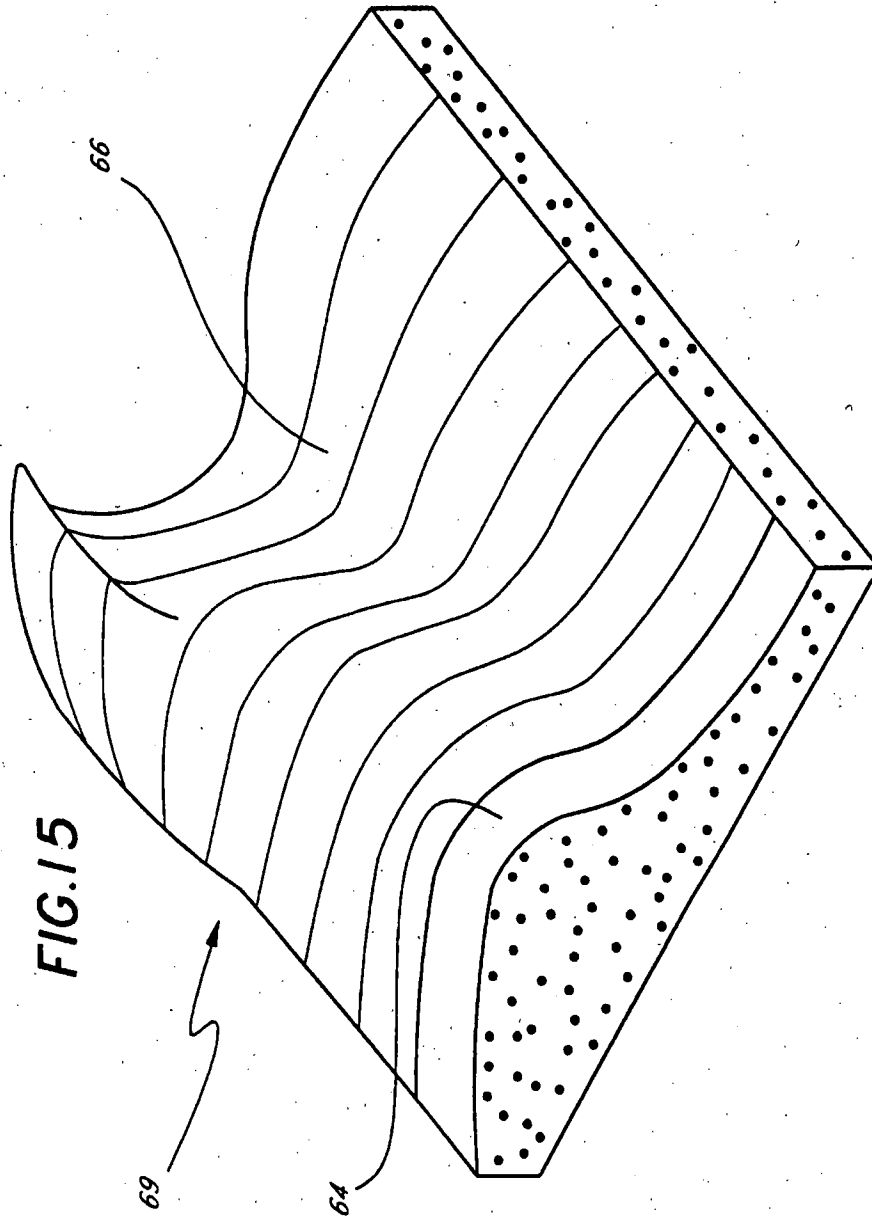

U.S. Patent

Aug. 17, 1993

Sheet 13 of 19

5,236,280

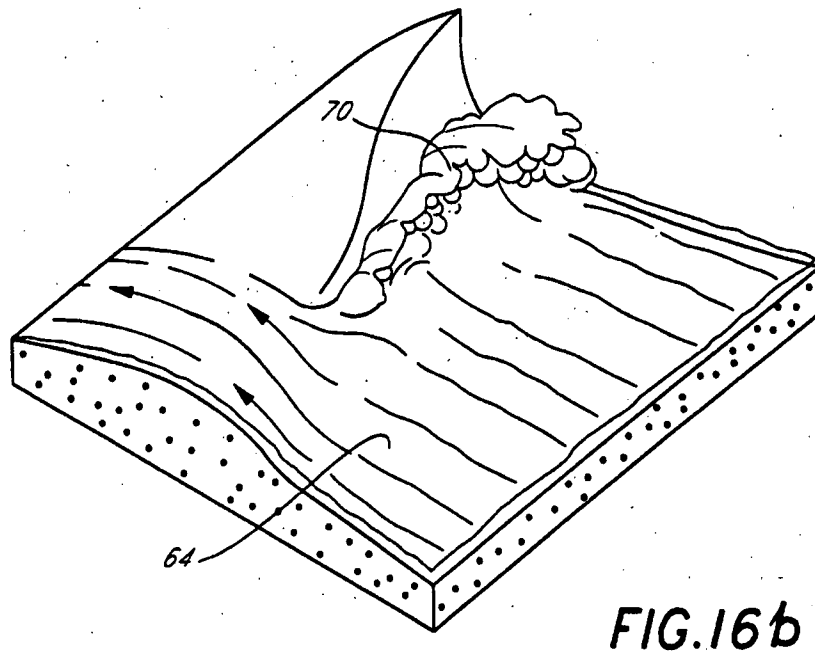
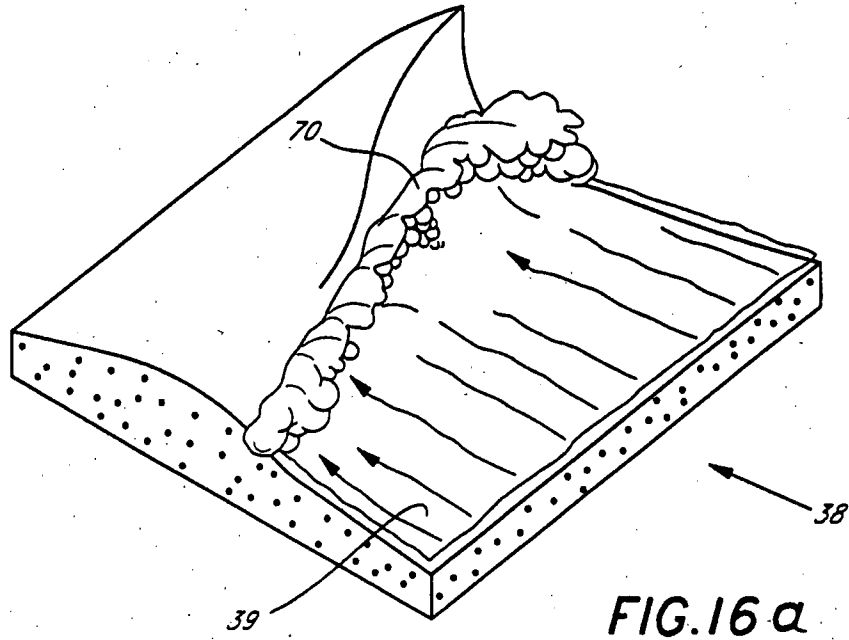

U.S. Patent

Aug. 17, 1993

Sheet 14 of 19

5,236,280

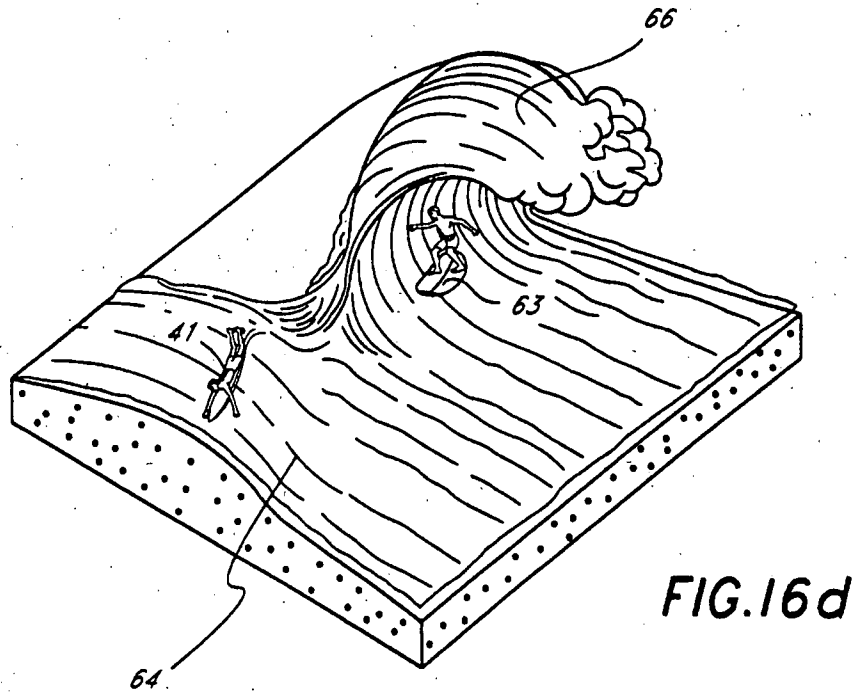
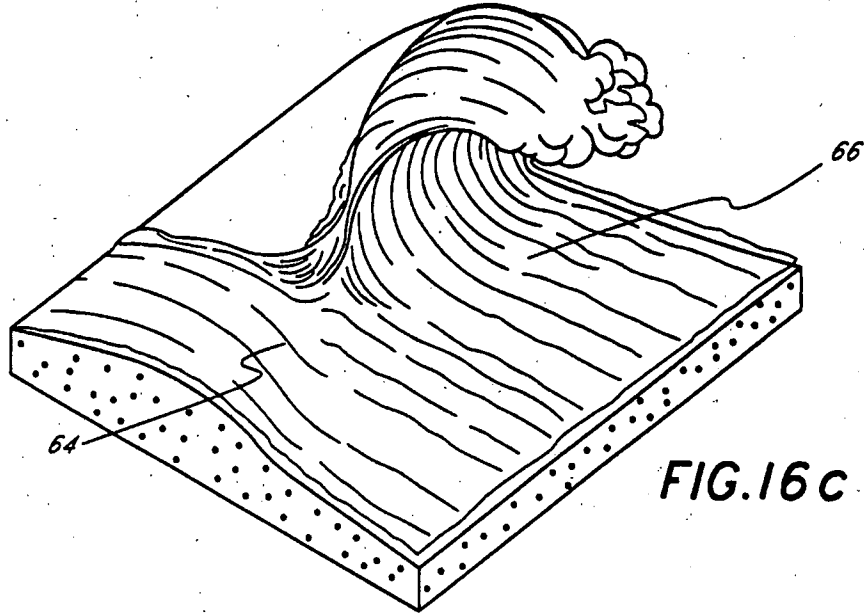

U.S. Patent

Aug. 17, 1993

Sheet 15 of 19

5,236,280

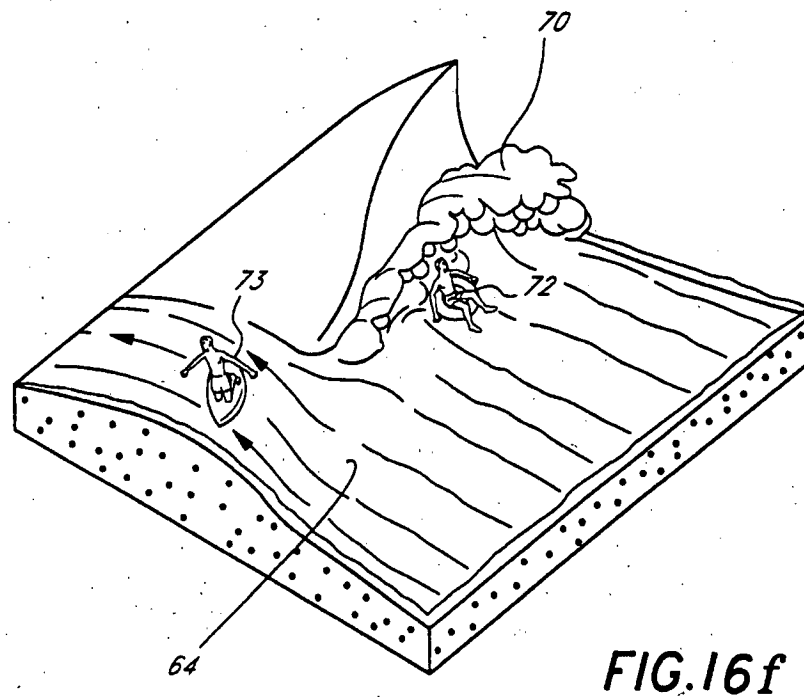
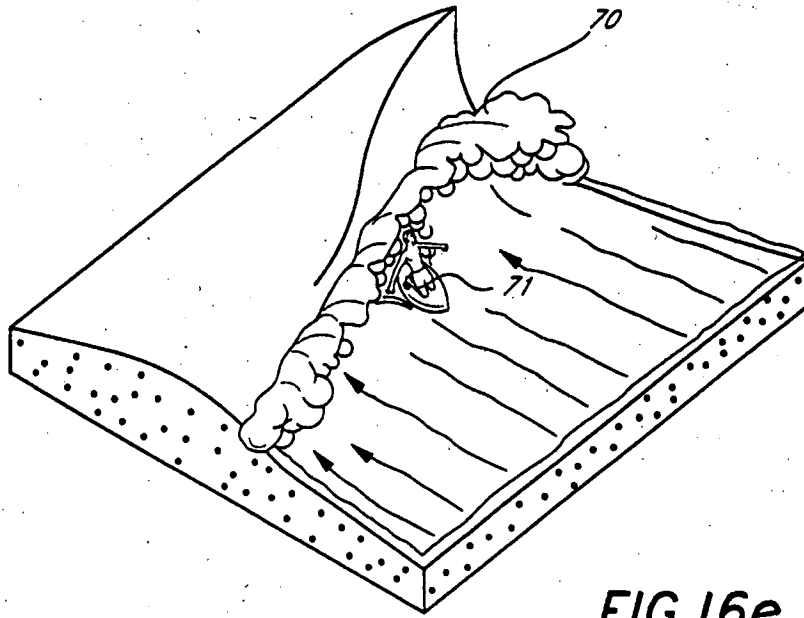

U.S. Patent

Aug. 17, 1993

Sheet 16 of 19

5,236,280

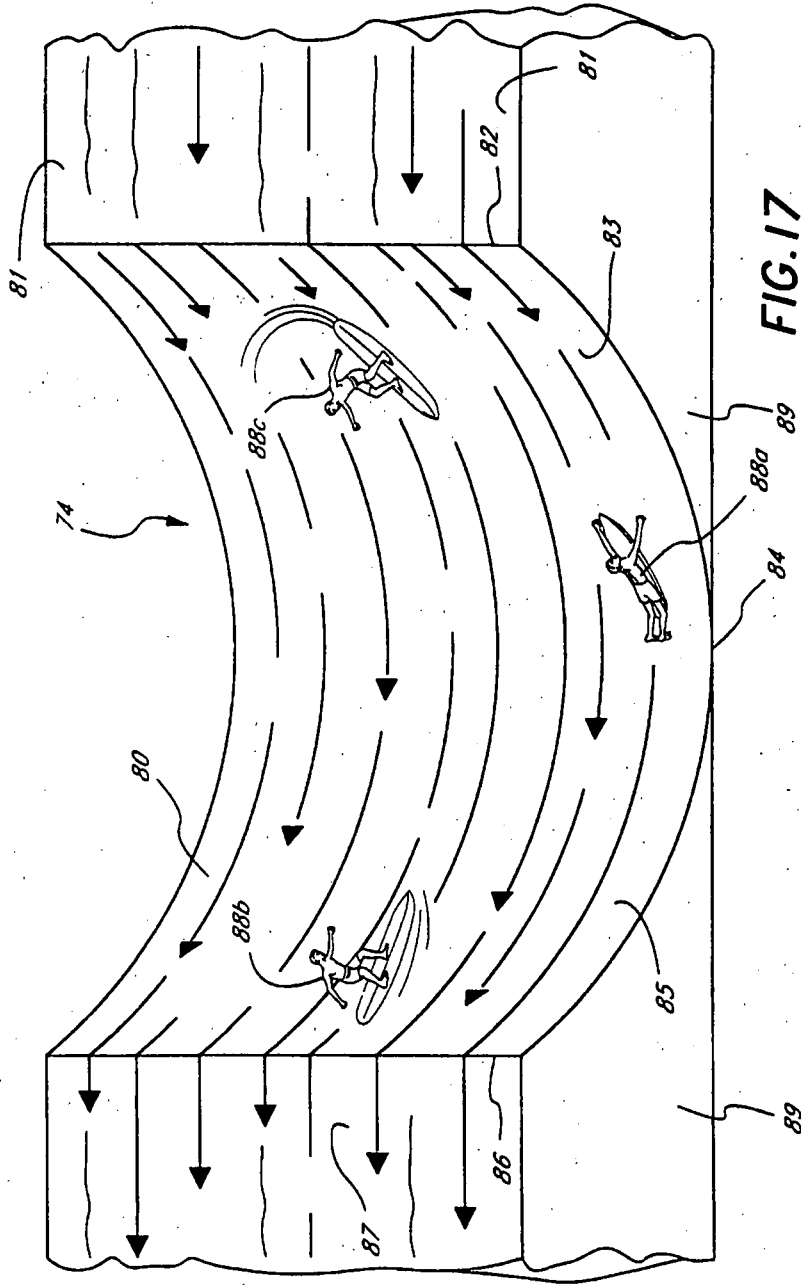

Exhibit 1



U.S. Patent

Aug. 17, 1993

Sheet 17 of 19

5,236,280

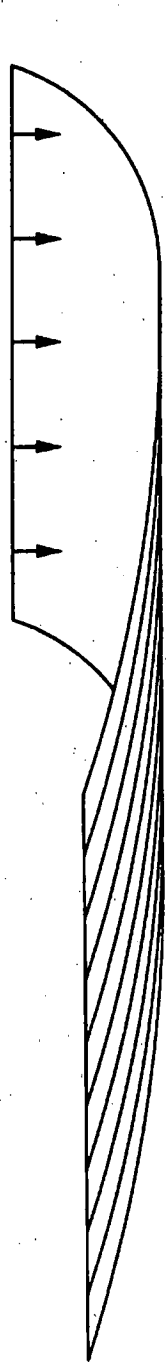

FIG. 18a

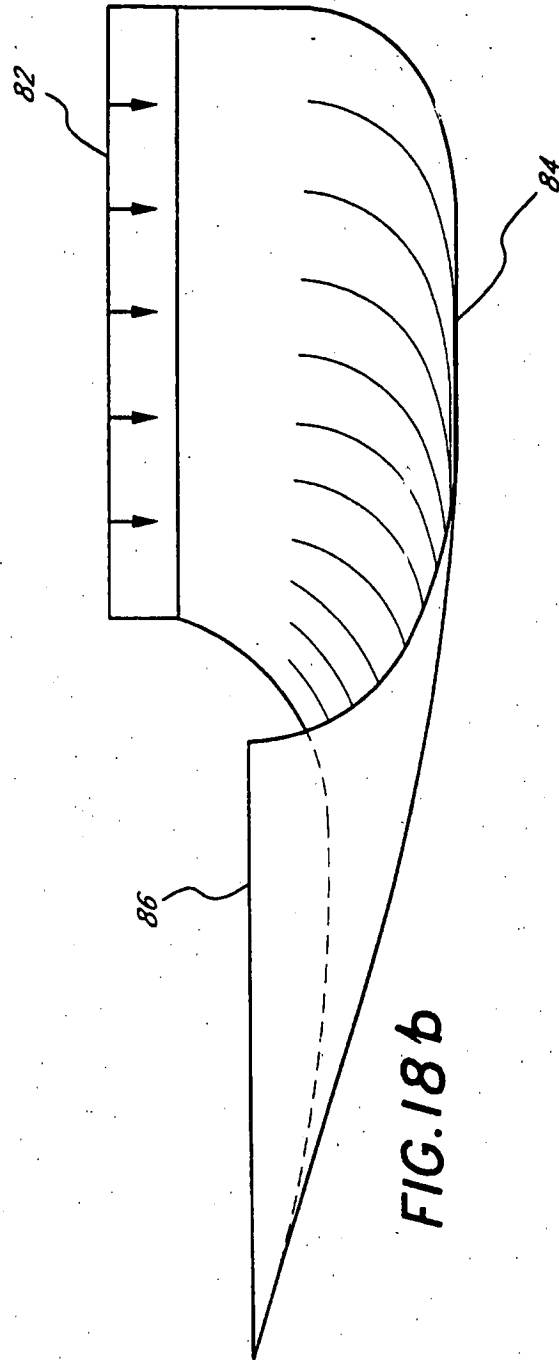

FIG. 18b

U.S. Patent

Aug. 17, 1993

Sheet 18 of 19

5,236,280

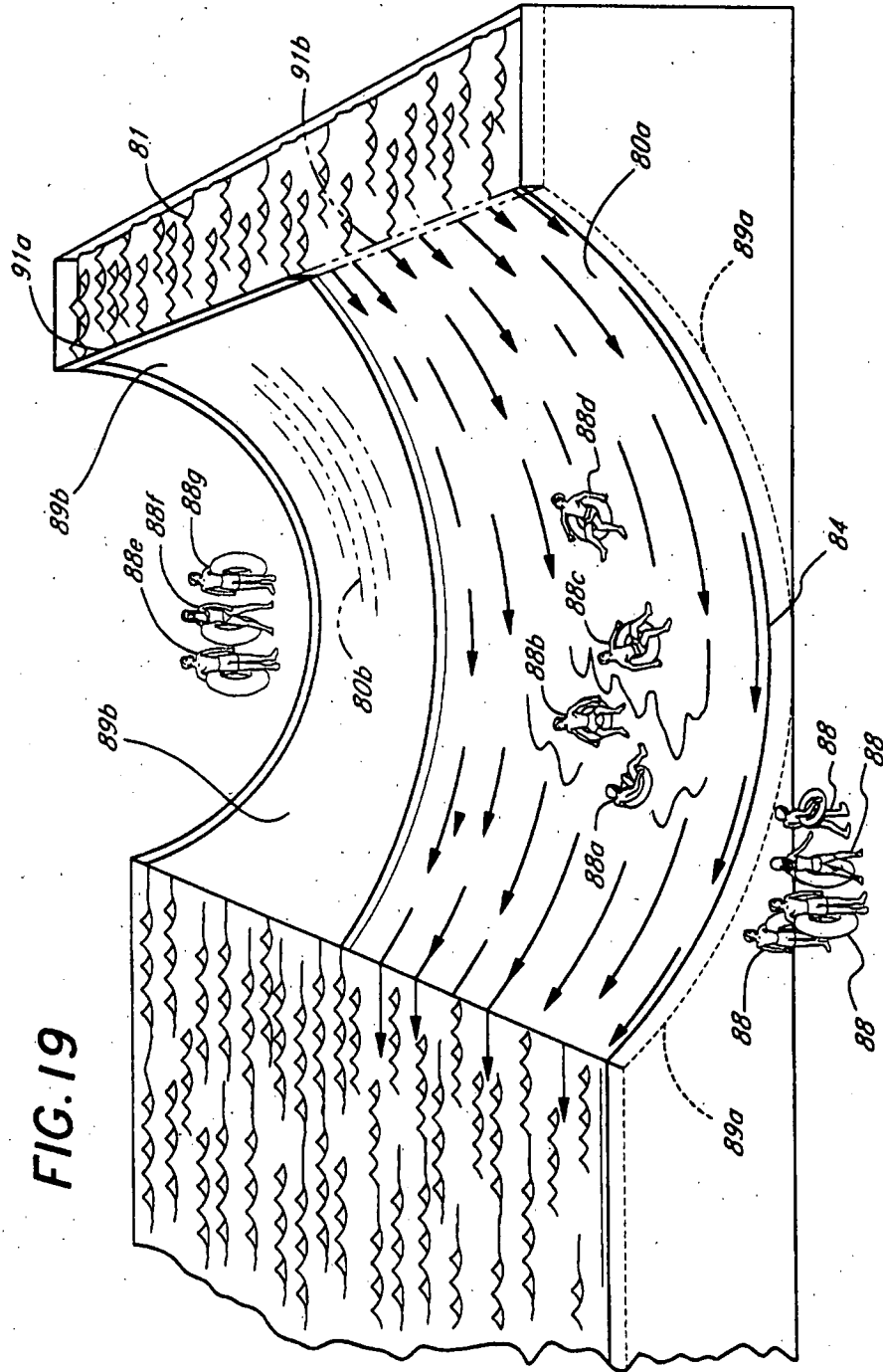

FIG. 19

U.S. Patent

Aug. 17, 1993

Sheet 19 of 19

5,236,280

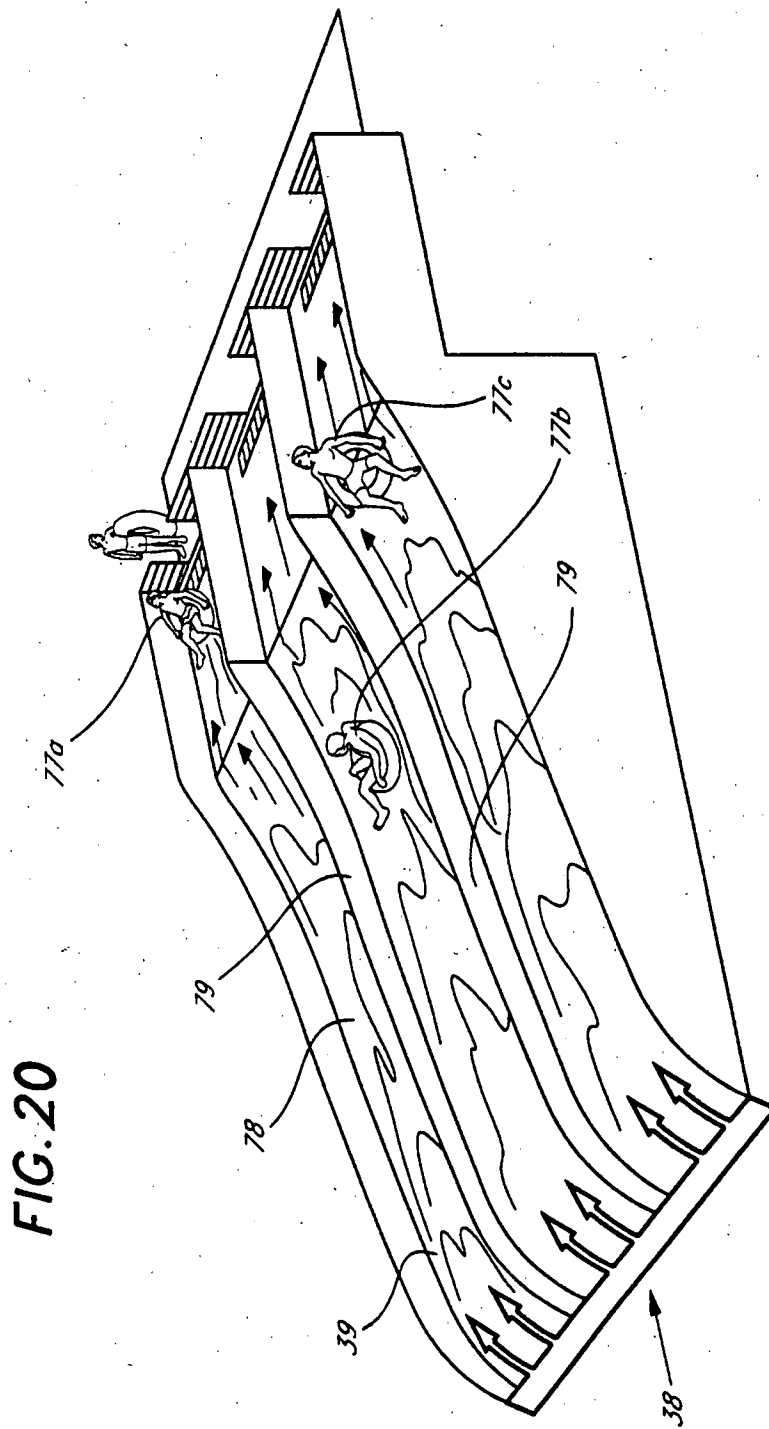

Exhibit 1

5,236,280

1

## METHOD AND APPARATUS FOR IMPROVING SHEET FLOW WATER RIDES

### RELATED APPLICATIONS

This application is a continuation-in-part of co-pending U.S. application Ser. No. 07/286,964, filed Dec. 19, 1988 for IMPROVEMENTS IN SURFING-WAVE GENERATORS, to be issued as U.S. Pat. No. 4,954,014 on Sep. 4, 1990, which is a continuation-in-part of U.S. application Ser. No. 07/054/521, filed May 27, 1987 for TUNNEL WAVE GENERATOR, issued as U.S. Pat. No. 4,792,260 on Dec. 20, 1988.

### FIELD OF THE INVENTION

The present invention relates in general to water rides, specifically a mechanism and process that provides a flowing body of water having flat, radial, and inclined surfaces thereon of sufficient area, depth and slope to permit surfboarding, skin-boarding, body-boarding, inner-tubing, and other water-skimming activity and, in particular, to several embodiments with means for generated, forming, maintaining, moving and riding said flow of water in a predominantly steady state condition.

### BACKGROUND OF THE INVENTION

For the past 25 years, surfboard riding and associated wave riding activities, e.g., knee-boarding, body or "Boogie" boarding, skim-boarding, surf-kayaking, inflatable riding, and body surfing (all hereinafter collectively referred to as wave-riding) have continued to grow in popularity along the world's surf endowed coastal shorelines. In concurrence, the 80's decade has witnessed phenomenal growth in the participatory family water recreation facility, i.e., the waterpark. Large pools with manufactured waves have been an integral component in such waterparks. Several classes of wavepools have successfully evolved. The most popular class is that which enables swimmers or inner-tube/inflatable mat riders to bob and float on the undulating swells generated by the wave apparatus. A few pools exist that provide large turbulent white-water bores that surge from deep to shallow pool end. Such pools enable wave-riding. However, white-water bore riding is not preferred by the cognoscenti of the wave-riding world, rather the forward smooth water face of a curling or tubing wave that runs parallel to the shoreline holds the ultimate appeal. Although numerous attempts have been made to establish wave-riding on curling waves as a viable activity in the commercial waterpark wavepool setting, such attempts have met with limited success. The reasons which underlie wave-riding's limited waterpark success is four-fold, 1) small spilling or unbroken waves which are ideal for the mass of novice waterpark attendees are not ideal for intermediate or advanced wave-riders; 2) the larger waves ideal for wave riding have proven prohibitive in cost to duplicate and become inherently more dangerous as their size increases; 3) the curling and plunging waves sought by advanced wave riders require steep and irregular pool bottom configurations that are inherently dangerous and can cause strong deep water current; 4) assuming a compromised and safer wave shape is acceptable to wave-riding participants, wave-riding is ideally a one-man-to-one-wave event that monopolizes an extended surface area. As consequence of limited wave quality, excessive cost, potential liability, and large

2

surface area to low rider capacity ratios, wavepools specifically designed for waveriders have proven unjustifiable to water park operators.

All wavepools that currently exist in the waterpark industry and the majority of previously disclosed wave-making inventions attempt to duplicate those types of oscillatory waves found naturally occurring at a beach. For purposes of definition, such waves are hereinafter termed "natural waves". Natural waves also include those found occurring in rivers as caused by submerged obstacles e.g., boulders. As known to those skilled in the art, natural waves have specific characteristics capable of mathematical description as a function of wave length, wave height, period, wave angle, velocity, phase speed, break speed, gravity, free surface water elevation, water depth, etc. Additionally, mathematical descriptions can be provided for a wide range of wave shapes progressing from an unbroken-to-breaking-to-broken. Breaking waves, those of most interest to waveriders, are traditionally classified as either spilling, plunging or surging. Broken waves can either be stationary (e.g., a river impacting on an obstacle creating a stationary hydraulic jump), or moving (e.g., an ocean white water surge or bore characterized by rapidly varied unsteady flow). The shape of a breaking wave is primarily a function of a given set of the aforementioned wave characteristics and the contour of the bottom over which the wave is moving. Beginning waveriders prefer the smaller gentle spilling wave produced by a gradually sloped bottom surface. Advanced waveriders prefer the larger plunging breakers that result from a steeply inclined beach. Since there are demographically a greater number of beginning wave-riders and since the wave favored by beginning riders is a product of an inherently safer gentle incline of beach, and since the energy and cost required to produce a small spilling wave is exponentially less than required to produce a large plunging wave, the current genre of wave pools have by necessity and practicality not been suitable for wave-riding by the more advanced wave rider.

The subject invention aims at creating a "wave shape" that can serve to provide those types of "wave shapes" desired by intermediate to advanced riders. Additionally, the subject invention seeks to accomplish such "wave shape" creation at a fraction of the cost and with an improved margin of safety as compared to that required to duplicate the aforementioned intermediate to advanced natural waves. The reason the subject invention can succeed at its goal is that it does not duplicate natural waves, rather, it creates "flow shapes" that are result of high velocity sheet flow over a suitably shaped forming surface. This concept of sheet flow formation versus natural wave formation is one of two primary distinguishing factors between the subject invention and the prior art.

This second distinguishing factor focuses on the forces that "drive" a wave rider when he is riding a wave. To this end, the subject invention defines two distinct classes of flow shapes, i.e., deep water flow shapes and shallow water flow shapes. A deep water flow shape is where the water depth is sufficient such that boundary layer effects of the sheet flow over the forming surface does not influence the operation of rider or riding vehicle, e.g., surfboard. Deep water flow shapes can, assuming certain flow forming and flow characteristics (e.g., velocity) are met, duplicate natu-

5,236,280

3

rally occurring waves. A shallow water flow shape is where the water is of such depth that the surface boundary layer effects of the sheet flow over the forming surface influences the operation of rider or riding vehicle, e.g., surfboard. As contemplated by the subject invention, shallow water flow shapes will never duplicate naturally occurring waves, because there are differing forces that come into play when a rider rides a shallow flow. As the result of those differing forces, the operational dynamics of the subject invention require that for shallow flows the average velocity of the water sheeting over the flow forming surface will always exceed the maximum velocity which would be found in a natural wave. To better explain why the shallow water flow velocity must always be greater than that of a deep water flow, and to further expand on the forces involved when a surfer rides an ocean wave or conversely when a "skimmer" rides a shallow water flow, the following examples are given: On a natural wave (a deep water flow environment) a surfer prior to starting a ride begins to move up the slope of the coming wave by primarily the forces of buoyancy. In order to overcome the forces of fluid drag, the surfer commences to paddle and take advantage of the interaction between the forces of buoyancy and gravity to provide a forward component to the surfboard and achieve riding speed. Thereafter, maintenance of a steady state position riding normal to the wave front is a balancing act between on the one hand, the hydrodynamic lift forces on the bottom of the surfboard coupled with buoyancy, and on the other hand, the forces of gravity and fluid drag. Cutting/trimming across the wave front (at an angle to the wave front) requires the same balancing act. If one attempts to reproduce the above described scenario in natural flow conditions, a large water depth is required. Likewise, in the laboratory setting this can be accomplished by deep water flows (reference the Killen papers, *infra*).

Conversely, in a shallow water flow environment, the forward force component of the "skimmer" and skimming device required to maintain a riding position and overcome fluid drag is due to the downslope component of the gravity force created by the constraint of the solid flow forming surface, balanced primarily by momentum transfer from the high velocity upward shooting flow. The "skimmer's" motion upslope (in excess of the kinetic energy of the "skimmer") consists of the force of the upward shooting flow exceeding the downslope component of gravity. In both deep water and shallow water flow environments, non-equilibrium riding maneuvers such as cross-slope motion and oscillating between different elevations are made possible by the interaction between the respective forces as described above and the use of the rider's kinetic energy.

The parent inventions to the subject applications have focused upon deepwater flow shapes specific to the performance of "surfing maneuvers". Surfing maneuvers, is defined by those skilled in the art, as those which occur under ocean like hydrodynamic conditions. Consequently, surfing maneuvers can be performed in an artificial environment, e.g., a wavepool, assuming that the wave which is produced duplicates the ocean wave riding experience (deep water flow) as described above. By corollary, true surfing maneuvers cannot be performed in shallow flow environments since the hydrodynamic conditions are distinct. However, full scale tests have demonstrated that the physical look and feel of "surfing like maneuvers" performed in

4

a shallow flow are surprisingly similar to "real" surfing maneuvers performed in a deep flow. For purposes of technical clarity, shallow flow "surfing type maneuvers" shall be termed as a subset of what hereafter can be described as "water skimming maneuvers". Water skimming maneuvers are defined as those activities which can be performed on shallow water flows including "surfing like maneuvers" as well as other activities or other types of maneuvers with differing types of vehicles e.g. inner-tubes, bodyboards, etc.

The subject invention discloses improvements to the prior art of shallow water flows, as well as similar improvements to the deep water flow shapes of the parent invention. The parent invention generated two types of stationary flow shapes, i.e., a stationary peeling tunnel flow shape for advanced waveriders, and a stationary non-breaking upwardly inclined flow shape for beginners.

#### DISCUSSION OF PRIOR ART

The water recreation field is replete with inventions that generate waves yet lacking as to inventions that create flow formed wave-like shapes. In all cases, none to date describe the improvements contemplated by the subject invention, as an examination of some representative references will reveal.

To facilitate distinction, the prior art can be divided into seven broad wave or wave shape forming categories:

Category 1—an oscillating back-and-forth or periodic up-and-down movement by an object or pressure source that results in disturbance propagation from point to point over a free water surface. Representative prior art: Fisch U.S. Pat. No. 1,655,498; Fisch U.S. Pat. No. 1,701,842; Keller U.S. Pat. No. 1,871,215; Matrai U.S. Pat. No. 3,005,207; Anderson U.S. Pat. No. 3,477,233; Presnell et al U.S. Pat. No. 3,478,444; Koster U.S. Pat. No. 3,562,823; Anderson U.S. Pat. No. 4,201,496; and Baker U.S. Pat. No. 4,276,664. The structure and operation of Category 1 prior art illustrate those types of devices which generate waves in an unsteady flow, i.e., a wave profile which will vary over distance and time.

Category 2—a moving hydraulic jump caused by the release of a quantity of water. Representative prior art: Dexter U.S. Pat. No. 3,473,334; Bastenhof U.S. Pat. No. 4,522,535; and Schuster, et al U.S. Pat. No. 4,538,719. Although differing in method, the structure and operation of Category 2 prior art is similar to Category 1 in that they generate waves in an unsteady flow, i.e., a wave profile which will vary over distance and time. As to the issues of water depth, direction of flow and direction of wave spill, the channel or pool bottoms of Category 2 devices constantly change in depth and become more shallow as one moves in the direction of the traveling wave and released water.

Category 3—a stationary hydraulic jump resulting in a spilling wave. Representative prior art: Le Mehaute U.S. Pat. No. 3,802,697.

Category 4—a moving hydraulic jump caused by a moving hull. Representative prior art: Le Mehaute '697 (*supra*) also disclosed movement by a wedge shaped body through a non-moving or counter-moving body of water, with such movement causing a hydraulic jump and resultant spilling wave suitable for surf-riding.

Category 5—a wave shape that simulates a stationary unbroken wave. Representative prior art: Frenzl U.S. Pat. No. 3,598,402 issued Aug. 10, 1971 is perhaps more

5,236,280

5

closely related in structure to the shallow water flow embodiments of the present invention than any of the previously discussed references. Frenzl disclosed an appliance for practicing aquatic sports such as surf-riding, water-skiing and swimming comprised of a vat, the bottom of which is upwardly sloping and has a longitudinal section which shows a concavity facing upwards while a stream of water is caused to flow upslope over said bottom as produced by a nozzle discharging water into the surface of the lower end of said bottom. Provision is made for adjustment of the slope of the vat bottom around a pivotal horizontal axis to permit the appliance to be adjusted for that sport which has been selected for practice, e.g., water skiing reduced slope or surf-riding increased slope. Provision is also made for varying the speed of the water from a "torrential flow" for water skimming activities, e.g., surfboard riding, to a "river type flow" wherein the speed of the water is matched to the speed of an exercising swimmer. However, Frenzl '402 does not recognize, either explicitly or implicitly some of the problems solved and advantages proffered by the present invention.

Frenzl U.S. Pat. No. 4,564,190 issued Jan. 14, 1986 shows improvements to the appliance for practicing aquatic sports using gliding devices (as disclosed in the Frenzl '402 patent) by introduction of a device that removes water from an upwardly sloping bottom surface which has been slowed down by friction at the boundary faces and returns the water to a pumping system to thereby increase the flow rate and thus eliminate the delirious effects of slowed down water. Frenzl U.S. Pat. No. 4,905,987 issued Mar. 6, 1990 shows improvements to the appliance disclosed in the Frenzl '402 patent (described above) by showing connected areas for swimming, non-swimming and a whirlpool so that water from the Frenzl '402 appliance is further utilized after outflow thereof. The primary objective of the Frenzl '987 patent is to improve the start and exit characteristics of the Frenzl '402 appliance by providing a means whereby a user can enter, ride, and exit the appliance to avoid breakdown of the torrential flow.

Category 6—a deflective wave shape that simulates a stationary tunnel wave. Representative prior art: Hornung, H.G. and Killen, P., "A Stationary Oblique Breaking wave for Laboratory Testing of Surfboards", *Journal of Fluid Mechanics* (1976), Vol. 78, Part 3, pages 459-484. P. D. Killen, "Model Studies of a Wave Riding Facility", 7th Australasian Hydraulics and Fluid Mechanics Conference, Brisbane, (1980). P. D. Killen and R. J. Stalker, "A facility for Wave Riding Research", Eight Australasian Fluid Mechanics Conference, University of Newcastle, N. S. W. (1983). The apparatus taught by Killen (all three articles will be collectively referred to as Killen, and each article is specifically referenced by chronological date of publication) forms a wave shape of the type favored by surfboard-riders, by placing a suitably shaped fixed position obstacle in a channel of specified width and in the path of a flow of water with specified depth and velocity such that deflection of the water off the obstacle duplicates the geometric and hydrodynamic aspects of a surface gravity wave that is obliquely incident to a sloping beach. At first glance, it may appear that structure as taught by Killen and that as disclosed by the subject invention are substantially similar. However, close examination will reveal significant differences.

In summary. Killen was attempting to create a wave shape that was geometrically and hydrodynamically

6

similar to the ideal wave in the real surfing situation. The "conforming wave shape" as formed by the shallow water flows of the subject invention does not attempt to geometrically and hydrodynamically simulate the ideal wave in the real surfing situation. The "conforming" deep water flows of the subject invention do not require such simulation, even though they can so simulate.

#### SUMMARY OF INVENTION

To better understand the objects and advantages of the invention as described herein, a list of special terms as used herein are defined:

(1) "deep water flow": that flow whereby the water depth is sufficient such that boundary layer effects of the sheet flow over the forming surface does not significantly influence the operation of rider or riding vehicle, e.g., surfboard. Deep water flow shapes can, assuming certain flow forming and flow characteristics (e.g., velocity) are met, duplicate naturally occurring waves.

(2) "shallow water flow": that flow whereby the water is of such depth that the surface boundary layer effects of the sheet flow over the forming surface significantly influences the operation of rider or riding vehicle, e.g., surfboard. Shallow water flow shapes will never duplicate naturally occurring waves.

(3) "surfing maneuvers": those maneuvers capable of performance on a surfboard which occur under ocean like hydrodynamic conditions, including deep water flows with the appropriate ocean approximating flow characteristics. Surfing maneuvers include riding across the face of the surface of water on a surfboard, moving down the surface toward the lower end thereof, manipulating the surfboard to cut into the surface of water so as to carve an upwardly arcing turn, riding back up along the face of the inclined surface of the body of water and cutting-back so as to return down and across the face of the body of water and the like, e.g., lip bashing, floaters, inverts, aerials, 360's, etc.

(4) "water skimming maneuvers": those maneuvers which can be performed on shallow water flows including "surfing like maneuvers" (i.e., similar to those described in "surfing maneuvers above) as well as, other activities or other types of maneuvers with differing types of vehicles e.g., inner-tubes, bodyboards, etc.

(5) "body of water": a volume of water wherein the flow of water comprising that body is constantly changing, and with a shape thereof at least of a length, breadth and depth sufficient to permit surfing or water skimming maneuvers thereon as limited or expanded by the respective type of flow, i.e., deep water or shallow water.

(6) "conform (conformed, conforming)", where the angle of incidence of the entire depth range of a body of water is (at a particular point relative to the inclined flow forming surface over which it flows) predominantly tangential to said surface. Consequently, water which flows upon an inclined surface can conform to gradual changes in inclination, e.g., curves, without causing the flow to deflect. As a consequence of flow conformity, the downstream termination of an inclined surface will always physically direct and point the flow in a direction aligned with the downstream termination surface. A conformed water flow is a non-separated water flow and a deflected water flow is a separated water flow, as the terms separated and non-separated are known by those skilled in the art.

5,236,280

7

(7) "equilibrium zone": that portion of an upwardly inclined body of water wherein a rider is in equilibrium depending on the one hand, on an upwardly directed force ascribable to the drag or resistance of the riders vehicle or body dipped into the stream of water and, on the other hand, on a downwardly directed force produced by the component of the weight of the rider in a direction parallel with the inclined water forming means.

(8) "supra-equidyne area": that portion of a body of water above the equilibrium zone wherein the slope of the incline is sufficiently steep to enable a rider to overcome the upwardly sheeting water flow and slide downwardly thereupon.

(9) "sub-equidyne area": that portion of a body of water below the equilibrium zone that is predominantly horizontal. In the sub-equidyne area a rider cannot achieve equilibrium and will eventually (due to the forces of fluid drag) be moved back up the incline.

One object of the present invention is to improve upon the parent invention by providing a flow forming surface upon which a shallow water flow can produce a body of water that is similar to the kind prized by surfers, i.e., a tunnel wave, which has a mouth and an enclosed tunnel extending for some distance into the interior of the forward face of the wave-shape. Such improvement is hereinafter referred to as the "Shallow Flow Tunnel Wave Generator." Heretofore, tunnel waves have only been available to surfers in a natural or deep water flow environment. The subject invention, through proper configuration of a flow forming surface and adequate shallow water flow characteristics (e.g., velocity, turbidity, depth, direction, etc.) can produce wave forms that have similar appearance and ride characteristics as "real" tunnel waves subject to certain ride conditions, e.g., limitation on surfboard fin size. However, the significant cost savings attributable to shallow flow construction and reduced energy consumption outweigh any limitations that may be imposed.

The parent invention also provided for a stationary non-breaking upwardly inclined deep water flow shape for beginners. The subject invention will also improve upon this embodiment of the parent invention through the use of shallow water flow technology. Such improvement is hereinafter referred to as the "Shallow Flow Inclined Surface." In addition to the significant advantage or reduced cost, additional advantages to the shallow water improvements described above include, increased safety due to reduced deep water pool depth, reductions in water maintenance due to decrease in volume of water treated, and the opportunities to create novel water sports, e.g., flowboarding or inner-tube "bumper cars".

A second object of the subject invention is to provide a flow forming means (hereinafter referred to as the "Connected Structure") comprised of a substantially horizontal flat surface (the sub-equidyne area) that transitions by way of a radial concave arc (the equilibrium zone) connected to the supra-equidyne area (e.g., the inclined plane or tunnel wave generator). The Connected Structure facilitates a riders ability to maximize his forward speed by the riders own efforts of "pump-turning", hereinafter more fully described as the "Acceleration Process". Without benefit of said Connected Structure such increased speed would not be available. The Connected Structure encompasses the complete spectrum of surface flows and wave shapes desired by wave-riding and water skimming enthusiasts. Beginning

8

at one extreme with a flat incline, and progressing by introduction of an increasing array of surface curvatures from the horizontal to the vertical combined with varying attitude and inclination of said surface relative to an upward (or downward, as the case may be) flow of water that culminates at the other extreme in a tunnel wave shape. A significant feature of the Connected Structure is how its unique configuration can dramatically improve the performance parameters of the parent invention's inclined Surface embodiment. The parent invention hereto permitted conventional surfing maneuvers; however, its structure did not optimally facilitate the generation of forward speed with which to perform such maneuvers. The "Acceleration Process" as now enabled by the Connected Structure improvement allows such forward speed to be attained.

A third object of the subject invention is to solve the transient surge problems associated with the ride start-up and rider induced flow decay upon upwardly inclined flow surfaces. This solution results by lowering the downstream boundary area of the inclined flow forming surface at an angle so as to create a maximum height ridge line of decreasing elevation to facilitate self-clearing of undesirable transitory surges. This improvement is hereinafter referred to as the "Self-Clearing Incline."

A fourth object of the subject invention and a novel ramification to the "Self-Clearing Incline" occurs by extending the inclined flow forming surface and associated ridge line of the downstream boundary area to an increased elevation. If such increase in elevation is in excess of the net total head flow necessary to scale this new increase in elevation, then the flow will form a hydraulic jump and the sub-critical water thereof will spill down the upwardly sheeting flow in the manner of a spilling wave. This improvement is hereinafter called the "Inclined Riding Surface with Spilling Wave". The spilling wave phenomena can also be incorporated into the other embodiments as described herein. A corollary improvement to any spilling wave application is a properly configured vent system to handle the water which spills back down the flow forming surface. If such water remained unvented, it would eventually choke the entire flow. Consequently, to maintain a steady state condition, to the extent that new water flows into the system, then, an equal amount of old water must vent out.

A fifth object of the subject invention is to improve by way of combination the tunnel and inclined flow forming surfaces, as well as, creation of an intermediate "spilling wave" that works in combination with the inclined flow surface. This embodiment is hereinafter referred to as the "Omni-Wave". A feature of the Omni-Wave embodiment is its unique flow forming shape can permit (by way of a progressive increase of the net head of the sheet flow) the transformation of a sheet of water flow from a stationary "spilling wave" along the entire forming means, to a transitional "spilling wave" with inclined surface flow, to the final inclined surface flow and tunnel wave shape. This method is hereinafter referred to as the "Wave Transformation Process". The Omni-Wave and the Wave Transformation Process will offer an improved environment for the performance of surfing and water skimming maneuvers.

A sixth object of the present invention is to provide an apparatus that will enable riders to perform surfing and water skimming maneuvers in a format heretofore unavailable except by analogy to participants in the separate and distinct sports of skateboarding and snow-

5,236,280

9

boarding, to wit, half-pipe riding. In this regard, the present invention comprises a method and apparatus for forming a body of water with a stable shape and an inclined surface thereon substantially in the configuration of a longitudinally oriented half-pipe. Such improvement is hereinafter referred to as the "Fluid Half-Pipe." A corollary improvement to the Fluid Half-Pipe is to provide an apparatus that permits an increased throughput capacity by increasing the depth of the Fluid Half-Pipe in the direction of its length. This increase in depth will have the added benefit of causing a rider to move in the direction of fall and facilitate his course through the ride.

The final object of the present invention is the positioning of dividers within a Fluid Half-Pipe or Inclined Surface as described above and to prevent a "jet wash" phenomenon that can result in loss of a rider's flow. This "jet wash" phenomenon occurs when a rider who is positioned in the equilibrium or supra-equidyne area of a thin sheet flow gets his flow of water cut off by a second rider positioned with priority to the line of flow. The cutting off of water occurs in thin sheet flow situations due to the squeegee effect caused by the second rider's skimming vehicle. The improvement aids in preventing adjacent riders from cutting off their respective flows of water. Such improvement is hereinafter referred to as "Sheet Flow Dividers."

Other objectives and goals will be apparent from the following description taken in conjunction with the drawings included herewith.

#### BRIEF DESCRIPTION OF THE DRAWINGS

FIG. 1 is a profile view of a Tunnel "Wave" Generator configured for shallow waterflows.

FIG. 2 is a contour map of Tunnel "Wave" Generator as set forth in FIG. 1.

FIG. 3 is a plan view of the range of horizontal attitude with respect to the direction of water flow that the wave generator (as set forth in FIG. 1) can take and still form a tunnel wave.

FIG. 4 is a view in profile of a typical cross-section disclosing the range of inclination of the forward face of the wave generator (as set forth in FIG. 1) with respect to the direction of water and orientation to the vertical.

FIG. 5 depicts a rider on the Tunnel Wave Generator.

FIG. 6 is a profile view of the inclined surface.

FIG. 7 is a cross-sectional view of the inclined surface as shown in FIG. 6.

FIG. 8 depicts a rider on the Inclined Surface.

FIG. 9a is a profile view of the Connected Structure.

FIG. 9b is a cross-section of FIG. 9a.

FIG. 10 depicts a surfer riding an Inclined Surface as improved by the Connected Structure and who is taking advantage of the acceleration process.

FIG. 11a is a profile view of the Self Clearing Incline.

FIG. 11b is a cross-section of FIG. 11a.

FIG. 12 is a contour map of the Self-Clearing Tunnel Wave.

FIG. 13a, FIG. 13b, and FIG. 13c are three views in profile that illustrate in time lapse sequence a self-clearing Inclined Surface.

FIG. 14a and FIG. 14b illustrate in time lapse sequence the self-clearing Tunnel Wave.

FIG. 15 is a profile of the Omni-Wave.

FIG. 16a depicts the Omni-Wave with a spilling wave formed along its entire front face.

10

FIG. 16b depicts the Omni-Wave with a clear inclined surface and a spilling wave.

FIG. 16c depicts the Omni-Wave with a clear inclined surface and a Tunnel Wave.

FIG. 16d depicts a Body Boarder performing water skimming maneuvers and a surfer performing surfing maneuvers on the Omni-Wave.

FIG. 16e depicts a knee boarder riding the spilling wave.

FIG. 16f depicts a water skier on the inclined surface and an inner-tube rider on the spilling wave.

FIG. 17 shows in profile view of a novel embodiment for water sports—the Fluid Half-Pipe.

FIG. 18a shows an elevation of a typical Fluid Half-Pipe.

FIG. 18b shows an elevation of a Fluid Half-Pipe with modified flow forming bottom to assist in capacity and rider throughput.

FIG. 19 illustrates in profile view an improvement to the Fluid Half-Pipe to assist in increased throughput capacity.

FIG. 20 shows dividers in a shallow flow to avoid flow "jet wash."

#### DETAILED DESCRIPTION OF THE SUBJECT INVENTION

Because the original application, the continuation of the original application and the subject invention are operated in water, and many of the results of its passage therethrough, or the propelling of water against the wave or flow forming means thereof, are similar to those caused by a boat hull, some of the terms used in the descriptions hereto will be nautical or marine terms; likewise, from the perspective of physical water dynamics, some of the terms used herein will be hydraulic engineering terms; and finally, from the perspective of ride operation and function, some of the terms used herein will be terms as used in the sport of surfing; all such terms constitute a ready-made and appropriate vocabulary which is generally understood by those skilled in the art. To the extent that there are special terms, then, those terms are further defined herein.

Further, it will be understood by those skilled in the art that much of the description of structure and function of the wave generator and inclined surface of the original application and its continuation application may apply to the embodiments of the subject invention, to the extent used by this application. Therefore, the descriptions of the flow forming means/wave generator hull and inclined surface of the prior applications should also be read in conjunction with FIGS. 1-20. However, to the extent there are any differences or discrepancies between the description and teaching of the prior applications and the subject invention, the description and teaching of the subject invention shall prevail.

Except where specifically limited, it is to be understood that the embodiments as described herein are to function in both deep and shallow flow environments. Furthermore, that the flow (except where noted) is to be super-critical (i.e., according to the formula  $v > \sqrt{gd}$  where  $v$ =velocity,  $g$ =acceleration due to gravity ft/sec<sup>2</sup>,  $d$ =depth of the sheeting body of water).

#### Description of Shallow Flow Tunnel "Wave" Generator

Turning now to FIG. 1 (isometric view) and FIG. 2 (contour map) there is illustrated a Tunnel "Wave" Generator 30 similar to the generator of prior applica-



5,236,280

11

tion, however, improved to serve in a shallow water flow. Plan-sectional lines as revealed in FIG. 1 and contour lines as revealed in FIG. 2 are solely for the purpose of indicating the three-dimensional shape in general, rather than being illustrative of specific frame, plan, and profile sections. Tunnel Generator 30 is comprised of a stem 31, a front face 32, a stern arch 33, an upstream edge 34 running from stem 31 to stern arch 33 and acting as the upstream perimeter of front surface 32, a downstream edge 35 running from stem 31 to stern arch 33 and acting as the downstream perimeter of front face 32, back surface 36, and sub-surface structural support 37. Front surface 32, bounded by upstream edge 34, downstream edge 35 and stern arch 33 is that feature of Tunnel Generator 30 which effectively shapes its tunnel "wave". Moving in a direction as indicated by arrow 38, super-critical shallow water flow 39 originating from a water source (not shown) moves in a conforming flow upward over the front face 32 to form an inclined body of water in the shape of a tunnel "wave" (not shown) upon which a rider (not shown) can ride. Back surface 36 is sufficiently smooth and with transitions analogous to a conventional waterslide such that a rider (not shown) could safely be swept over or around Tunnel Generator 30 to a termination pool or area (not shown) to properly exit. The outside dimensions of the flow forming front face 32 of Tunnel Generator 30 are capable of a broad range of values which depend more upon external constraints, e.g., financial resource, availability of water flow, etc., rather than specific restrictions on the structure itself. However, for purposes of scale and not limitation, in order to form a tunnel "wave" of adequate size to fully accommodate an adult user, the outside dimensions of Tunnel Generator 30 should be approximately 1 to 3 meters in height and 3 to 12 meters in length.

At least three characteristics of front face 32 of Tunnel Generator 30 influence the size, shape and angle of the tunnel "wave," and each of them interacts with the others:

- A. its shape (FIGS. 1 and 2);
- B. its attitude—its horizontal position or angle with respect to the direction of water flow (FIG. 3); and
- C. its inclination—its vertical position or angle with respect to the direction of water flow (FIG. 4).

Each characteristic of front face 32 is now discussed in detail.

#### A. Shape

Front face 32 of Tunnel Generator 30 has a complex shape comprised of concave curvature, both vertically and horizontally, as indicated generally by the FIG. 1 plan sections lines and FIG. 2 contour lines. Such lines are substantially but not specifically illustrative of the range of possible shapes, as will now be explained more fully:

##### 1. Vertically:

- a. the shape of the vertical curvature can be:
  - (1) substantially a simple arc of a circle; or
  - (2) preferably an arc of a more complex changing curve, e.g.:
    - (a) ellipse;
    - (b) parabola;
    - (c) hyperbola; or
    - (d) spiral.

If a changing curve, it preferably changes from an opening curve (i.e., the ascending water encounters an increasing radius as it ascends front face 32) at stem 31

12

through a transition point 40; to a closing curve (i.e., the ascending water encounters a decreasing radius as it ascends front face 32) from transition point 40 to stern arch 33. A critical feature of Tunnel Generator 30 is that commencing at transition point 40, front face 32 begins to curve past the vertical. Curvature past the vertical from transition point 40 towards the stern arch 33 gradually increases from 0 to a maximum of 30 degrees. 10 degrees if preferred.

##### 2. Horizontally

a. The shape of the horizontal curvature can be:

- (1) substantially an arc of a circle; or
- (2) preferably, a portion of a more complex, changing curve, e.g.:
  - (a) ellipse;
  - (b) parabola;
  - (c) hyperbola; or
  - (d) spiral.

##### B. Attitude

As disclosed in FIG. 3, the horizontal attitude of front face 32 with respect to direction 38 of water flow can vary only within certain limits otherwise the "tunnel" will not develop. Since front face 32 has concave curvature of varying degrees along its horizontal axis, for purposes of orientation an extension of upstream edge 34 is used to indicate varying horizontal attitudes of front face 32 therefrom. Accordingly, upstream edge 34 can vary from substantially perpendicular to the direction 38 of water flow to an angle of approximately 35 degrees, as shown.

##### C. Inclination

As disclosed in FIG. 4, the inclination of the front face 32 with respect to the direction 38 of water flow is also limited, otherwise the tunnel will not be developed. Two factors are important with respect to inclination, first, the change in angle of incline relative to the depth of the water must be sufficiently gradual to avoid separation of flow lines/deflection. Second, the angle of release (as defined by a line tangent to front face 32 at downstream edge 35 when compared to the vertical) must be past the vertical as shown. Amounts past vertical may vary, however, a preferred amount is 10 degrees.

At least two other factors effect the size and shape of tunnel wave formation, i.e., flow velocity and water flow depth. The velocity of the water over Tunnel Generator 30 has a wide range, dependent upon the overall size of the Tunnel Wave Surface and the depth of water. In general, the flow is to be super-critical (i.e., according to the formula  $v > \sqrt{gd}$  where  $v$ =velocity,  $g$ =acceleration due to gravity ft/sec<sup>2</sup>,  $d$ =depth of the sheeting body of water). However, velocities in excess of that which is at a minimum necessary to achieve supercritical velocity are sometimes desired, e.g., to provide sufficient momentum transfer to support the weight component of a given rider, and to achieve the vertical heights required to form a tunnel "wave."

The depth of the water is primarily a function of the minimum necessary to permit a tunnel "wave" to form at a given height, and simultaneously enable the flow of water to support (via momentum transfer) the weight component of a contemplated range of users. Because of the operational requirements of momentum transfer, the depth of the water has direct relationship to the velocity of the water, i.e., the higher the velocity of flow, the lower the requisite depth. Since this embodiment is

5,236,280

13

limited to shallow flows, the depth of water will range from approximately 2 to 40 centimeters.

Tunnel Generator 30 can be fabricated of any of several of well known materials which are appropriate for the use intended. Concrete; formed metal, wood, or fiberglass; reinforced tension fabric; air, foam or water filled plastic or fabric bladders; or any such materials which will stand the structural loads involved. A preferred embodiment includes a thick foamed plastic covering to provide additional protection for the riders using the facility.

Theoretically, no pool or water containment means is required for Tunnel Generator 30, in that the flow from a suitable flow source (e.g., pump and nozzle, fast moving stream or elevated reservoir/lake) is all that is required. However, where water recycling is preferred, then, low channel walls can be constructed to retain the flowing water with a lower collection pool, recycling pump and appropriate conduit connected back to the upstream flow source. The area of channel containment need be only large enough to allow the performance of appropriate water skimming maneuvers, since the curling water of the tunnel wave would remain more or less stationary with respect to the containment structure. Thus, such a structure could be constructed even in a backyard.

From the description above, a number of advantages of Tunnel "Wave" Generator 30 becomes evident:

(a) The energy required to produce a tunnel "wave" shape under shallow flow conditions is dramatically less than that required under "natural" conditions, e.g., as indicated in Killen's 1980 article, the power required to produce operational natural waves is proportional to the height of the wave raised to the 3.5 power ( $hw^{3.5}$ ). Consequently, a 2 meter wave would require 11.3 times the power of a 1 meter wave or approximately 3.7 megawatts or 4800 horsepower. An 8 cm in depth shallow flow wave as contemplated by the subject invention with similar width to Killen's structure would be able to produce a 2 meter high tunnel "wave" for under 400 horsepower.

(b) The capital costs and operating costs for shallow water tunnel "wave" generation is substantially less than deep water installations.

(c) The sight, sound, and sensation of tunnel "wave" riding is a thrilling participant and observer experience, that has heretofore only been available to relatively few people in the world. The subject invention will enable this experience to become more readily available.

(d) From a safety perspective, shallow water is generally perceived as safer in view of drowning.

#### Operation of the Tunnel "Wave" Generator

FIG. 5 illustrates Tunnel Generator 30 in operation with the concavity of front face 32 acting to shape a water walled tunnel from super-critical shallow water flow 39 within and upon which rider 41 can ride. Water flow 39 originating from a water source (not shown) moves in a direction 38 as indicated. At stem 31 water flow 39 moves over front face 32 and onto back surface (not shown). Back surface (not shown) is sufficiently smooth and with transitions analogous to a conventional waterslide such that rider 41 could safely be swept over or around Tunnel Generator 30 to a termination pool or area (not shown) to properly exit. Progressing from transition point 40 to stern arch 33 the horizontal and vertical concavity of front face 32 acts as a scoop to channel and lift water into the central portion

14

of front face 32 towards stern arch 33. Combined with the attitude of Tunnel Generator 30 relative to the direction 38 of water flow 39, the resultant forces thereto propel water flow 39 along the path of least resistance which is upward and outward creating the desired tunnel 42. Tunnel 42 size is adjustable depending upon the velocity of water flow 39, i.e., the higher the flow velocity the larger the tunnel effect. The forward force component required to maintain rider 41 (including any skimming device that he may be riding) in a stable riding position and overcome fluid drag is due to the downslope component of the gravity force created by the constraint of the solid flow forming surface balanced primarily by momentum transfer from the high velocity upward shooting water flow 39. Rider's 41 motion upslope (in excess of the kinetic energy of rider 41) consists of the force of the upward shooting water flow 39 exceeding the downslope component of gravity. Non-equilibrium riding maneuvers such as cross-slope motion and oscillating between different elevations on the "wave" surface are made possible by the interaction between the respective forces as described above and the use of the rider's kinetic energy.

Accordingly, it should now be apparent that Tunnel "Wave" Generator 30 embodiment of this invention can use shallow water flow in a water ride attraction to simulate ocean tunnel waves. In addition, Tunnel "Wave" Generator 30 has the following advantages:

it requires a fraction of the energy utilized in generating a "real" wave;

it costs substantially less to build and maintain;

it allows a rider to experience the sight, sound, and sensation of tunnel wave riding, an experience that heretofore has not been available in commercial settings;

it uses shallow water which is inherently safer than deep water in the prevention of drowning.

#### Description of Shallow Flow Inclined Surface

Turning now to FIG. 6, there is illustrated shallow flow inclined surface 44. Plan-sectional lines as revealed in FIG. 6 are solely for the purpose of indicating the three-dimensional shape in general, rather than being illustrative of specific frame, plan, and profile sections. Shallow flow inclined surface 44 is comprised of sub-surface structural support 45; back surface 46; and front face 47 which is bounded by an imaginary downstream ridge line 48, an upstream edge 49, and side edge 50a and 50b. Side edge 50 can have walls (not shown) or be connected with conventional broad surfaced downhill sliding transitions (not shown) to either contain or allow a rider to move out and off of the flow. Front face 47 can either be a gradual sloping inclined plane, a continuous concave planar surface, a concave planar surface joined to a convex planar surface, or preferably a combination of planar curved surfaces and planar inclined surfaces. FIG. 7 shows in cross-section a preferred profile of front face 47 with upstream edge 49 (indicated as a point in this cross-sectional view) as the upstream boundary and with a combination of curves and straight inclines as follows: concave curvature 51 as one moves upwards towards the downstream ridge 48 (indicated as a point in this cross-sectional view); concave curvature 51 transitioning to a straight incline 52 at a concave/straight transition point 53; straight incline 52 continuing to straight/convex transition point 55; and convex curvature 56 from straight/convex transition point 55 to downstream ridge 48. Back surface 46 joins front face

5,236,280

15

47 at the downstream ridge line 48. Back surface 46 is sufficiently smooth and with transitions analogous to a conventional waterslide such that a rider (not shown) could safely be swept over downstream ridge line 48 to a termination pool or area (not shown) to properly exit. 5 Turning back to FIG. 6, super critical water flow 39 originating from a water source (not shown) moves in direction 38 to produce a conforming upward flow over front face 47, the downstream ridge line 48 and onto the back surface 46 to form an inclined body of water upon which a rider (not shown) can ride. The outside dimensions of the flow forming front face 47 of shallow flow inclined surface 44 are capable of a broad range of values which depend more upon external constraints, e.g., financial resource, availability of water flow, etc., rather than specific restrictions on the structure itself. 15

The velocity of the water over shallow flow inclined surface 44 has a wide range, dependent upon the overall size of the inclined surface and the depth of water. In general, the flow is to be super-critical (i.e., according to the formula  $v > \sqrt{gd}$  where  $v$ =velocity,  $g$ =acceleration due to gravity ft/sec<sup>2</sup>,  $d$ =depth of the sheeting body of water). However, velocities in excess of that which is at a minimum necessary to achieve super-critical velocity are sometimes desired, e.g., to provide sufficient momentum transfer to support the weight component of a given rider, and to achieve the vertical heights required to form an unbroken "wave." 25

The depth of the water is primarily a function of that which is necessary to successfully operate for the purposes intended. Because of the operational requirements of momentum transfer, the depth of the water has direct relationship to the velocity of the water, i.e., the higher the velocity of flow, the lower the requisite depth. Since this embodiment is limited to shallow flows, the depth of water will range from approximately 2 to 40 centimeters. 30

Shallow flow inclined surface 44 can be fabricated of any of several of well known materials which are appropriate for the use intended. Concrete; formed metal, wood or fiberglass; reinforced tension fabric; air, foam or water filled plastic or fabric bladders; or any such materials which will stand the structural loads involved. A preferred embodiment includes a thick foamed plastic covering to provide additional protection for the riders using the facility. 35

Theoretically, no pool or water containment means is required for shallow flow inclined surface 44, in that the flow from a suitable flow source (e.g., pump and nozzle, fast moving stream or elevated reservoir/lake) is all that is required. However, where water recycling is preferred, then, low channel walls can be constructed to retain the flowing water with a lower collection pool, recycling pump and appropriate conduit connected back to the upstream flow source. The area of channel containment need be only large enough to allow the performance of appropriate water skimming maneuvers. Thus, such a structure could be constructed even in a back yard. 40

From the description above, a number of advantages of Shallow Flow Inclined Surface 44 becomes evident: 45

(a) The energy required to produce an unbroken "wave" shape similar to that simulated by Shallow Flow Inclined Surface 44 is dramatically less than that required under "natural" conditions. e.g., as indicated in Killen's 1980 article, the power required to produce operational natural waves is proportional to the height of the wave raised to the 3.5 power ( $hw^{3.5}$ ). Conse-

16

quently, a 2 meter wave would require 11.3 times the power of a 1 meter wave or approximately 3.7 mega watts or 4800 horsepower. An 8 cm in depth shallow flow wave as contemplated by the subject invention with similar width to Killen's structure would be able to produce a 2 meter high inclined surface "wave" for under 400 horsepower.

(b) The capital costs and operating costs for shallow water inclined surface "wave" generation is substantially less than deep water installations. 10

(c) The sight, sound, and sensation of inclined surface "wave" riding is a thrilling participant and observer experience, that has heretofore only been available to relatively few people in the world. The subject invention will enable this experience to be become more readily available.

(d) From a safety perspective, shallow water is generally perceived as safer in view of drowning.

#### Operation of Shallow Flow Inclined Surface

FIG. 8 illustrates Shallow Flow Inclined Surface 44 in operation. Super-critical water flow 39 originating from a water source (not shown) moves in direction 38 to produce a conforming upward flow over front face 47, the downstream ridge line 48 and onto the back surface 46 to form an inclined body of water upon which rider 41 can ride. Front face 47 serves as the primary riding area for rider 41. On this area rider 41 will be able to perform skimming maneuvers as follows: The forward force component required to maintain rider 41 (including any skimming device that he may be riding) in a stable riding position and overcome fluid drag is due to the downslope component of the gravity force (created by the constraint of sub-surface structural support 45) balanced primarily by momentum transfer from the high velocity upward shooting water flow 39. The motion of rider 41 in an upslope direction (in excess of the kinetic energy of rider 41) consists of the force of the upward shooting water flow 39 exceeding the down slope component of gravity. Non-equilibrium riding maneuvers such as cross-slope motion and oscillating between different elevations on the "wave" surface are made possible by the interaction between the respective forces as described above and the use of rider's 41 kinetic energy. Back surface 46 is sufficiently smooth and with transitions analogous to a conventional waterslide such that rider 41 could safely be swept over downstream ridge line 48 to a termination pool or area (not shown) to properly exit. 50

Accordingly, it should now be apparent that Shallow Flow Inclined Surface 44 embodiment of this invention can use shallow water flow in a water ride attraction to simulate unbroken ocean waves. In addition, Shallow Flow Inclined Surface 44 has the following advantages: 55

it requires a fraction of the energy utilized in generating a "real" wave;  
it costs substantially less to build and maintain;  
it allows a rider to experience the sight, sound, and sensation of continuous unbroken wave riding, an experience that hereto for has not been available in commercial settings. Such capability will greatly expand the training of beginning "surf-riders" and provide a venue for surf-camps, etc.  
it uses shallow water which is inherently safer than deep water in the prevention of drownings.

5,236,280

17

## Description of Connected Structure

The Connected Structure creates additional surface area beyond the areas defined by Tunnel Wave Generator 30 and Shallow Flow Inclined Surface 44. In general terms, this expanded area can be described as a horizontal area upstream of the upstream edge of each respective embodiment. Furthermore, the Connected Structure describes specific ratios between three distinct regions that can be defined to exist on Tunnel Wave Generator 30 and Shallow Flow Inclined Surface 44 as improved by the Connected Structure. Through combination of area expansion and defined region size relationship, a flow forming means can be described with performance characteristics as yet undisclosed by the prior art.

Turning now to FIG. 9a, we see a generalized diagram of an improvement for a flow forming means herein called Connected Structure 57. Plan-sectional lines as revealed in FIG. 9a are solely for the purpose of indicating the three-dimensional shape in general, rather than being illustrative of specific frame, plan, and profile sections. Connected Structure 57 is comprised of a supra-equidyne area 58, which transitions (as represented by a dashed line 59) to an equilibrium zone 60, which in turn transitions (as represented by a dotted line 61) to a sub-equidyne area 62. The dimensions and relationship of Connected Structure's 57 sub-equidyne 62, equilibrium 60, and supra-equidyne 58 areas are described as follows:

FIG. 9b illustrates a cross-section of Connected Structure 57, with sub-equidyne area 62, equilibrium zone 60, and supra-equidyne area 58 with a range of configurations 58a, 58b, and 58c that are capable of producing a flow that ranges from the previously described unbroken "wave" (i.e., inclined flow) and the tunnel "wave" flow.

The preferred embodiment for the breadth of the sub-equidyne area 62 in the direction of flow 38 is, at a minimum, one and one half to four times the vertical height (as measured from sub-equidyne to the top of supra-equidyne) of the total flow forming means. The large breadth would apply to low elevation means (e.g., 1 meter) and smaller breadth to high elevation means (e.g., 6 meters). Sub-equidyne 62 orientation is substantially horizontal and normal to the force of gravity.

The preferred embodiment for the shape of equilibrium zone 60 can be defined by a portion of a changing curve, e.g., an ellipse; parabola; hyperbola; or spiral. If a changing curve, the configuration of equilibrium zone 60 is substantially arcs of a closing curve (i.e., the ascending water encounters a decreasing radius as it ascends the face of the flow forming means). The radius of said closing curve being at its smallest approximating the radius of supra-equidyne 58 leading edge, and at its longest less than horizontal. For purposes of simplicity and scale (but not by way of limitation) the uphill breadth of equilibrium zone 60 can generally be defined by a distance approximately equal to the length of the rider's flow skimming vehicle, i.e., approximately three to ten feet.

The preferred embodiment for the shape of supra-equidyne area 58 can be defined by a portion of changing curve, e.g., an ellipse; parabola; hyperbola; or spiral. If a changing curve, the configuration of supra-equidyne area 58 is initially arcs of a closing curve (i.e., the ascending water encounters a decreasing radius as it ascends the face of the flow forming means). The radius

18

of said closing curve is at its longest always less than the radius of the longest arc of equilibrium zone 60, and, at its smallest of sufficient size that a rider could still fit inside a resulting "tunnel wave". On the opposite end of the spectrum, said arcs of a closing curve can transition, after a distance at least equal to  $\frac{1}{3}$ 's the length of the riders flow skimming vehicle (approximately two to seven feet), to arcs of an opening curve (i.e., the ascending water encounters an increasing radius as it ascends the face of the flow forming means). The only limitation as to the overall breadth of supra-equidyne area 58 in the direction of flow 38 is the practical limitation of available head of an upwardly sheeting flow.

Super-critical water flow 39 originating from a water source (not shown) moves in direction 38 to produce a conforming flow over sub-equidyne area 62, equilibrium zone 60, and supra-equidyne area 58 to form an inclined body of water upon which a rider (not shown) can ride and perform surfing or water skimming maneuvers that would not be available but for such Connected Structure 57.

## Operation of the Connection Structure

The significance of Connected Structure 57 is a function of how it can be used to enable the performance of surfing and water skimming maneuvers. Essential to the performance of modern surfing and skimming maneuvers are the elements of oscillation, speed, and proper area proportion in the "wave" surface that one rides upon. Each element is elaborated as follows:

## OSCILLATION:

The heart and soul of modern surfing is the opportunity for the rider to enjoy substantial oscillation between the supra-critical and sub-critical areas: As one gains expertise, the area of equilibrium is only perceived as a transition area that one necessarily passes through in route to supra and sub critical areas. Oscillatory motion has the added advantage of allowing a rider to increase his speed.

## SPEED

Speed is an essential ingredient to accomplish modern surf maneuvers. Without sufficient speed, one cannot "launch" into a maneuver. The method and means for increasing one's speed on a properly shaped wave face can be made clear by analogy to the increase of speed on a playground swing as examined in SCIENTIFIC AMERICAN, March 1989, p. 106-109. On a swing, if one is crouching at the highest point of a swing to the rear, one's energy can be characterized as entirely potential energy. As one descends, the energy is gradually transformed into kinetic energy and one gains speed. When one reaches the lowest point, one's energy is entirely kinetic energy and one is moving at peak speed. As one begins to ascend on the arc, the transformation is reversed: one slows down and then stops momentarily at the top of the arc. Whether one goes higher (and faster) during the course of a swing depends on what one has done during such swing. If one continues to crouch, the upward motion is a mirror image of the downward motion, and one's center of mass ends up just as high as when one began the forward swing. If instead one stands when one is at the lowest point, i.e., "pumping" the swing, then one would swing higher and faster.

The importance of sub-equidyne area 62 in the context of the previous discussion of swing dynamics, is that sub-equidyne area 62 is by its nature the lowest point on Connected Structure 57 and on a wave. Standing/extending at this low point results in a larger in-

5,236,280

19

crease of speed than if one stood at any other point on Connected Surface 57 or on a wave. This increase in speed and total kinetic energy is due to two different mechanistic principals, both of which may be utilized by a rider on Connected Structure 57 or a wave. By standing at the lowest point in the oscillatory path, the center of gravity of the rider is raised allowing a greater vertical excursion up the slope than the original descent. Crouching at the top of the path and alternately standing at the bottom allows an increase in vertical excursion and restoration of energy lost to fluid drag. Additionally, the other mechanism, increasing the kinetic energy, is due to the increase in angular rotation. As the rider in his path rotates around a point located up the wave face, extension/standing at the low point increases his angular velocity much in the same manner as a skater by drawing in his/her arms increases his/her rotational speed due to the conservation of momentum. However, kinetic energy increases due to the work of standing against the centrifugal force and because kinetic energy is proportional to the square of angular velocity, this increase in kinetic energy is equivalent to an increase in speed.

#### PROPER AREA PROPORTION:

Connected Structure 57 as a flow forming surface combines in proper proportion the sub-critical 62, equilibrium 60, and supra-critical 58 areas so as to enable a rider to oscillate, attain the requisite speed and have available the requisite transition area for performance of modern day surfing and skimming maneuvers that would not be possible, but for said Connected Structure 57.

Turning to FIG. 10 there is illustrated a surfer 63 on an inclined surface as improved by Connected Structure 57 in various stages of a surfing maneuver. Surfer 63 is in a crouched position on supra-equidyne area 58 and gathering speed as he moves downward over a conformed sheet of super-critical water flow 39 which originates from a water source (not shown) and moves in direction 38. Upon reaching the low point at sub-equidyne area 62, surfer 63 extends his body and simultaneously carves a turn to return to supra-equidyne area 58. As a consequence of such maneuvering, surfer 63 will witness an increase in speed to assist in the performance of additional surfing maneuvers. The process by which a surfing or water skimming rider can actively maneuver to increase his speed is referred to as the Acceleration Process.

#### Description of Self-Clearing Incline and Tunnel Wave

Turning to FIG. 11a (isometric view) and FIG. 11b (cross-sectional view) there is illustrated a top vent self-clearing incline improvement for Shallow Flow Inclined Surface (as improved by Connected Structure) all of which is hereafter referred to as a Self-Clearing Incline 64. Self-Clearing Incline 64 is comprised of Shallow Flow Inclined Surface as modified by lowering the elevation of side edge 50b' and causing downstream ridge line 48 to incline from the horizontal. FIG. 11b superimposes a cross-sectional profile of side edge 50a over the lowered side edge 50b'. To have a noticeable effect, the angle of inclination should be a minimum 5 degrees.

Turning to FIG. 12 (contour map) there is illustrated a swale self-clearing incline improvement for Tunnel "Wave" Generator 30 (as improved by Connected Structure 57) all of which is hereafter referred to as Self-Clearing Tunnel Wave 66, comprised of sculpting

20

from front surface 32, sub-equidyne area 62 and structural matrix support 37 (not shown) a shallow venting swale 65. All surfaces of swale 65 are smooth and without edges.

#### Operation of Self-Clearing Incline and Tunnel Wave

Self-Clearing Incline 64 and Self-Clearing Tunnel Wave 66 are designed to prevent unwanted turbulent white water build-up that fails to clear from the riding surface in the usual manner of "washing" over the downstream ridge of these respective embodiments. In practice, this vent problem will only occur if there is a restriction on flow venting to the side of the inclined surface or generator, e.g., a channel wall, or where there is a tremendous amount of activity, e.g., multiple riders on the surface of the water.

This undesirable build-up is particularly acute in an upward directed flow. This build-up will most likely occur during three stages of operation, (1) water flow start-up with no rider present; (2) transferring the kinetic energy of high speed water flow to a maneuvering rider; and (3) cumulative build-up of water due to a spilling wave. In the start-up situation (1), due to the gradual build up of water flow associated with pump-/motor phase in or valve opening, the initial rush is often of less volume, velocity or pressure than that which issues later. Consequently, this initial start water is pushed by the stronger flow, higher pressure, or faster water that issues thereafter. Such pushing results in a build-up of water (a hydraulic jump or transient surge) at the leading edge of the flow. An upward incline of the riding surface serves only to compound the problem, since the greater the transient surge, the greater the energy that is required to continue pushing such surge in an upward fashion. Consequently, the transient surge will continue to build and if unrelieved will result in overall flow velocity decay, i.e., the slowed water causes additional water to pile up and ultimately collapse back onto itself into a turbulent mass of bubbling white water that marks the termination of the predominantly unidirectional super-critical sheet flow. In the situation of kinetic energy transfer (2), when a maneuvering rider encounters faster flowing water or water that is moving in a direction different than the rider, a transient surge builds behind or around the rider. Likewise, if this transient surge grows too large it will choke the flow of higher speed unidirectional super-critical sheet flow, thus, causing flow decay. In the situation of an excessive build up of water over time from a spilling wave (3), the interference of a preceding flow with a subsequent flow can result in an undesired transient surge and flow decay at a point near where the two flows meet. Under all three conditions, it is possible to control or eliminate the transient surge by immediately increasing the flow pressure and over-powering or washing the transient surge off the riding surface. However, there comes a point where the build-up of water volume is so great that for all practical purposes over-powering is either impossible, or at best, a costly solution to a problem capable of less expensive solution. Such less expensive solution is possible by the introduction of vents.

Two classes of vent mechanisms are identifiable. The first class, self-clearing inclines, are used to clear transient surges from inclined surfaces. FIGS. 13a, 13b, and 13c show in time lapse sequence how the design of self-clearing incline 64 operates to solve the problem of a pressure/flow lag during start-up. In FIG. 13a water

5,236,280

21

flow 39 has commenced issue in an uphill direction from water source (not shown) in direction 38. As water flow 39 moves up front surface 47, the leading edge of water flow is slowed down by a combination of the downward force of gravity and friction with front surface 47, whereupon, it is overtaken and pushed by the faster and stronger flow of water that subsequently issued from the water source. The result of this flow dynamic is that a transient surge 68 begins to build. However, as transient surge 68 builds, it reaches the height of low side edge 50b' and commences to spill over onto back surface 46. FIG. 13b shows this start procedure moments later wherein the water pressure/flow rate from the water source has increased and transient surge 68 has moved further up the incline. FIG. 13c shows the final stage of start-up wherein the transient surge has been pushed over the top of Down Stream Ridge Line 48 and water flow 39 now runs clear. Similar to the start-up procedure, when a lower speed rider encounters the higher speed water, or when an accumulative build-up of water results from a spilling wave, a transient surge may occur. In like manner, the transient surge will clear by spilling off to the lowered side accordingly.

The second class of vent mechanism, swale vents, are used to assist in clearing transient surges from tunnel wave generators. FIGS. 14a and 14b show in time lapse sequence how the design of swale 67 operates to solve identical problems as suffered by the inclined surfaces with channel walls. In FIG. 14a water flow 39 has commenced issue in an uphill direction from water source (not shown) in direction 38. Transient surge 68 begins to build. However, as transient surge 68 builds, it commences to vent into swale 67, thus, permitting tunnel wave 42 to properly form as shown in FIG. 14b.

#### Description and Operation of the Omni-Wave

FIG. 15 depicts a preferred embodiment herein named an Omni-wave 69 comprised of Self-Clearing Incline 64 which is interconnected and continuous with Self-Clearing Tunnel Wave 66.

FIG. 16a, FIG. 16b, FIG. 16c, FIG. 16d, FIG. 16e and FIG. 16f illustrates Omni-Wave 69 in operation. A unique feature of Omni-Wave 69 is its unique flow forming shape can permit (by way of a progressive increase of the net head of the water flow) the transformation of super-critical water flow 39 that originates from a water source (not shown) in direction 38 to a stationary spilling wave 70 along the entire forming means (as illustrated in FIG. 16a); to a stationary spilling wave 70 with Self Clearing Incline 64 flow (as illustrated in FIG. 16b); to a Self-Clearing Incline 64 and Self-Clearing Tunnel Wave 66 flow (as illustrated in FIG. 16c). This progressive wave forming method is hereinafter referred to as the "Wave Transformation Process". The Omni-Wave and the Wave Transformation Process will offer an improved environment for the performance of surfing and water skimming maneuvers. FIG. 16d shows surfer 63 and rider 41 on Self-Clearing Tunnel Wave 66 and Self-Clearing Incline 64 respectively. FIG. 16e shows surfer water skimming kneeboarder riding upon stationary spilling wave 70, FIG. 16f shows inner-tube rider 72 and water skier 73 on stationary spilling wave 70 and Self-Clearing Incline 64 respectively.

#### Description and Operation of the Fluid Half Pipe

Turning to FIG. 17 wherein an apparatus is revealed that will enable riders to perform surfing and water

22

skimming maneuvers in a format heretofore unavailable except by analogy to participants in the separate and distinct sports of skateboarding and snowboarding, to wit, half-pipe riding. Fluid Half-Pipe 74, comprises a method and apparatus for generating a body of water 80 with a stable shape and an inclined surface thereon substantially in the configuration of a half-pipe with the opening of said half-pipe facing in an upwards direction. The water 81 which supplies said body of water flows over the leading edge 82 of the half-pipe flow forming means 89 and down one side (hereinafter referred to as the down-flow-side 83), in a direction perpendicular to the length of said half-pipe, across an appropriate sub-equidyne flat section 84, and up and over the other side of the half-pipe (hereinafter referred to as the up-flow-side 85), across the trailing edge 86, and into an appropriate receiving pool 87 or other suitably positioned Fluid Half Pipe or attraction. A rider 88a enters the flow at any appropriate point, e.g., sub-equidyne flat section 84, wherein as a result of his initial forward momentum of entry, the excessive drag of his water-skimming vehicle, and the added drag of the riders weight induced trim adjustments to his riding vehicle, said rider (now 88b) is upwardly carried to a supra-critical area in the upper regions of up-flow-side 85 near the half pipe's trailing edge 86, wherein as a result of the force of gravity in excess of the drag force associated with the riding vehicle and the riders own weight trim adjustments to reduce drag, rider (now 88c) hydroplanes down the up-flow-side 85, across the sub-equidyne flat 84, and performs a turn on down flow side 83 to return to up-flow-side 85 and repeat cycle.

As can be appreciated by those skilled in the art, Fluid Half-Pipe 74 will offer its participants a consistent environment in which to perform known surfing and water skimming maneuvers, and due to the combination of up-side-flow, flat, and down-side-flow a unique environment in which to perform new maneuvers unachievable on existing wave surfaces.

The preferred embodiment for the breadth of the flow forming means 89 of Fluid Half-Pipe 74 approximates Connected Structure 57 joined to its mirror image at the midpoint of sub-equidyne 62. It is preferred that said width remain constant for the length of flow-forming means 89, however, variations in width with resultant variations in cross-sectional shape are possible. The limitations on minimum and maximum width is a function of ones ability to perform surfing and water skimming maneuvers. If the flow forming means is too narrow, a rider would be unable to negotiate the transition from the up-flow side 85 to the down-flow-side 83 or vice versa. If too wide, a rider would not be able to reach or utilize the down-flow side 83 to perform surfing and water skimming maneuvers.

A preferred embodiment for the length of the flow forming means of Fluid Half-Pipe 74 is at a minimum a length sufficiently wide to perform surfing and water skimming maneuvers thereon, and at a maximum a function of desire and/or budget.

A preferred embodiment for the cross-sectional shape of the up-flow side's flow forming means has been shown in FIG. 9b and discussed above. FIG. 9b illustrated a detailed cross-section of Connected Structure 57, with sub-equidyne area 62, equilibrium zone 60, and supra-equidyne area 58. Caution must be taken in the design of the up-flow-side 85 supra-equidyne area to insure proper water flow up and over the trailing edge 86. Excessive steepness or height that results in un-

5,236,280

23

timely or improperly located spilling or tunneling waves can result in an excessive build-up of turbulent white water in the sub-equidyne flat area 84 which may culminate in complete deterioration of the up-side-flow. However, since advanced riders, in order to maximize speed and perform certain maneuvers, e.g., aerials, prefer a steep supra-critical area that approaches or exceeds vertical then it is preferred that spilling or tunnel wave formation (if any) be limited to areas adjacent the side openings of half-pipe 74, and that the majority middle half pipe 74 be substantially the shape as illustrated in FIG. 9b with supra-equidyne configuration 58a.

Generally, the elevation of half-pipe 74 leading edge 82 will exceed its line-of-flow position on half-pipe 74 trailing edge 86. This differential in elevation will insure that the water of said body of water 81 will have sufficient dynamic head to overcome all internal and external friction that may be encountered in its circuit down, across, up, and over flow forming means 89. The preferred ratio by which the down-flow-side exceeds the up-flow-side ranges from a minimum of ten to nine to a maximum of ten to one. It is also preferred that the respective leading and trailing edge 82 and 86 remain at constant elevations along the length of the half-pipe. Variations in elevation are possible, however, source pool water 81 dynamics, receiving pool water 87 dynamics, and maintenance of line of flow dynamic head must be accounted for.

In cross-sectional profile, a standard configuration for Fluid Half Pipe 74 is illustrated in FIG. 18a. In this standard configuration the cross-sectional elevation, width, and depth remains constant for the length of half-pipe 74. FIG. 18b illustrates an asymmetrical configuration, wherein, the leading and trailing edges 82 and 86 remain at constant elevations and the width between trailing edges remains constant, however, the distance between trailing edges and the flat sub-equidyne section 84 continues to increase at a constant rate of fall. The object of this particular asymmetrical embodiment is to increase throughput capacity for half-pipe 74 as the result of rider movement in the direction of fall due to the added vector component of gravity force ascribed to the weight of the rider in the direction of fall.

The preferred velocity of water in the subject invention is substantially a function of the overall drop in distance from leading edge 82 to the flat area 84. Consequently, previously discussed preferences in the overall height of the Connected Structure dictate the preferred water velocity. Such velocity can be calculated in accordance with Bernoulli's equation  $v = \sqrt{2gz}$  where  $v$  is the velocity in feet per second,  $g$  is gravity  $\text{ft}/\text{sec}^2$  and  $z$  = vertical distance dropped in feet.

The preferred depth of water is that which is required to perform surfing and water skimming maneuvers. For purposes of Half Pipe 74 the minimum depth is 2 cm. and the maximum depth is whatever one might be able to afford to pump. Except the desirable spilling/tunnel wave formation adjacent a side-opening of half-pipe 74, an additional preference is that the water avoid excessive turbulence that results from a hydraulic jump which occurs when the velocity of a sheeting body of water exceeds a certain critical velocity at a certain minimum depth.

Variations in the breadth and longitudinal movement of the body of water that flows upon the half-pipe can result in enhancements to rider throughput capacity for

24

the Fluid-Half Pipe. FIG. 19 depicts a half-pipe configured flow forming means 89. A stably shaped body of water 80a is situated on one side 89a of said flow forming means. The water 81 which supplies said stably shaped body of water is limited by a dam 91a to just one-half of the flow forming means 89. Riders 88a, b, c and d enter the flow at any appropriate point, e.g., the sub-equidyne flat section 84 and perform water skimming maneuvers thereon. As shown in FIG. 19, the water skimming maneuvers are performed using an inner-tube type vehicle. After an elapsed period of time, e.g., several minutes, a dam 91b is positioned to block the water 81 which supplies the stably shaped body of water 80a on side 89a of said flow forming means. Upon blockage of the source of water, the stably shaped body of water 80a soon ceases to exist on side 89a of said flow forming means. Consequently, the riders 88a, b, c and d drift to the sub-equidyne section 84 and can easily exit. Simultaneously with, or shortly after the blockage by dam 91b, dam 91a opens and water 81 begins to flow over flow forming means 89b, whereupon forming a stably shaped body of water 80b that remains situated on side 89b. Riders 88e, f, and g enter the flow and commence to perform water skimming maneuvers for their allotted time span, whereupon dam 91a is re-positioned and the cycle is set to repeat.

FIG. 20 illustrates super-critical water flow 39 originating from a water source (not shown) moving in direction 36 to produce a conforming upward flow over front face 78. Dividers 79 provide separation for the individual riders 77a, 77b, and 77c and to prevent a "jet wash" phenomenon that can result in loss of a rider's flow. This "jet wash" phenomenon occurs when a rider who is positioned in the equilibrium or supra-equidyne area of a thin sheet flow gets his flow of water cut off by a second rider positioned with priority to the line of flow. The cutting off of water occurs in thin sheet flow situations due to the squeegee effect caused by the second rider's skimming vehicle.

As will be recognized by those skilled in the art, certain modifications and changes can be made without departing from the spirit or intent of the present invention. For example, the curvatures given as examples for the Connected Structure do not have to be geometrically precise; approximations are sufficient. The same is true of limits in angles, radii and ratios. The temperature and density of the water will have some difference although the range of temperatures in which surfer/riders would be comfortable is fairly limited.

The terms and expressions which have been employed in the foregoing specifications are used therein as terms of description and not of limitation, and there is no intention, in the use of such terms and expressions, of excluding equivalents of the features shown and described, or portions thereof, it being recognized that the scope of the invention is defined and limited only by the claims which follow.

I claim:

1. An amusement apparatus for water sports activities utilizing a stably-shaped body of water having a surface thereon, comprising:
  - means for forming a substantially horizontal body of water, said horizontal body of water having a substantially horizontal surface thereon;
  - said horizontal body of water moving in a predetermined direction over said horizontal forming means with a first horizontal velocity, wherein said horizontal body of water has a shape and dimen-

5,236,280

25

sions thereof that are substantially stable with respect to time;  
 means for forming an upwardly inclined body of water, said inclined body of water having an upwardly inclined surface thereon;  
 means for joining said horizontal forming means to said upwardly inclined forming means;  
 said horizontal body of water moving over said joining means and on to said upwardly inclined forming means to form said upwardly inclined body of water, wherein said upwardly inclined body of water moves over said upwardly inclined forming means with a second velocity; and  
 said upwardly inclined surface of said upwardly inclined body of water having a slope sufficient to permit an object floating by condition of motion thereon to slide down said upwardly inclined surface with a third velocity, relative to said second velocity, at least as great as the negative of said second velocity.

2. An apparatus as defined in claim 1 wherein said means for forming said upwardly inclined body of water includes first and second interconnected inclined surfaces, said first inclined surface being connected to said means for forming said horizontal body of water, said second inclined surface being connected to said first inclined surface to provide a continuous flow of water over said horizontal surface and said first and second inclined surfaces, said second inclined surface having greater angular inclination with respect to said horizontal surface than said first inclined surface.

3. An apparatus as defined in claim 2 wherein the angular inclination of the second inclined surface is sufficient to permit an object floating by condition of motion thereon to slide down said second inclined surface with a velocity greater than the negative of said second velocity.

4. An apparatus as defined in claim 3 wherein the minimum length in the direction of flow of said horizontal flow forming means is equal to 1.5 to 4 times the total vertical height of said means for forming said upwardly inclined body of water.

5. An apparatus as defined in claim 4 wherein said first inclined surface has a length in the direction of flow which is at least equal to the length of a device being employed by a user of said apparatus.

6. An apparatus as defined in claim 4 wherein said first inclined surface is curved.

7. An apparatus as defined in claim 4 wherein said first inclined surface is straight.

8. An apparatus as defined in claim 6 wherein said body of water substantially conforms to said horizontal surface, and said first and second inclined surfaces.

9. The apparatus as defined in claim 1 wherein said upwardly inclined body of water and said horizontal body of water have sufficient depth to permit surfing maneuvers thereon.

10. The apparatus as defined in claim 1 wherein said upwardly inclined surface of water and said horizontal surface of water have sufficient width and length to permit surfing maneuvers thereon.

11. An amusement apparatus for water sports activities using a body of water flowing in a predetermined direction, comprising:  
 means for forming an upwardly inclined body of water, said inclined body of water having an upwardly inclined surface thereon;

26

said forming means having an elevated ridge line, said ridge line having first and second ends, wherein said first end has a greater elevation than said second end; and  
 said upwardly inclined body of water moving over said upwardly inclined forming means with a range of velocity and volume to a pre-determined maximum, said inclined body of water:  
 having a shape and dimensions thereof that are proportional to predetermined velocity and volume ratios, and having:  
 at a minimum, a shape and dimensions thereof that are substantially stable with respect to time along said second end, and having a white water breaking region maintained upstream of said first end; and  
 at a maximum, a shape and dimensions thereof along said second end and along said first end that are substantially stable with respect to time; having at a minimum, velocity and volume sufficient to form, over a period of time, an inclined body of water that at least flows over said other side; and having at a maximum, velocity and volume sufficient to form an inclined body of water that flows over said other side and said one side.

12. The apparatus as defined in claim 11 further comprising:  
 means for forming an upstream horizontal body of water with a horizontal surface thereon;  
 said horizontal body of water moving over said horizontal forming means with a first horizontal velocity, wherein said horizontal body of water has a shape and dimensions thereof that are substantially stable with respect to time;  
 means for joining said horizontal forming means to said upwardly inclined forming means; and  
 said horizontal body of water moving over said joining means and on to said upwardly inclined forming means to form said upwardly inclined body of water with said upwardly inclined surface thereon.

13. The apparatus as defined in claim 12 further comprising:  
 means for forming an upstream downwardly inclined body of water with a downwardly inclined surface thereon;  
 said downwardly inclined body of water moving over said downwardly inclined forming means with a downward velocity, wherein said downwardly inclined body of water has a shape and dimensions thereof that are substantially stable with respect to time;  
 means for joining said downwardly inclined forming means to said horizontal forming means; and  
 said downwardly inclined body of water moving over said joining means and on to said horizontal forming means to form said horizontal body of water with said horizontal surface thereon.

14. The apparatus as defined in claim 11 wherein said upwardly inclined body of water having sufficient depth to permit surfing maneuvers thereon, and wherein said upwardly inclined surface of water having sufficient width and length to permit surfing maneuvers thereon.

15. The apparatus as defined in claim 12 wherein said upwardly inclined body of water and said horizontal body of water having sufficient depth to permit surfing maneuvers thereon, and wherein said upwardly inclined surface of water and said horizontal surface of water



27

having sufficient width and length to permit surfing maneuvers thereon.

16. An apparatus as defined in claim 13 wherein said upwardly inclined body of water and said horizontal body of water and said downwardly inclined body of water having sufficient depth to permit surfing maneuvers thereon, and wherein said upwardly inclined surface of water and said horizontal surface of water and said downwardly inclined surface of water having sufficient width and length to permit surfing maneuvers thereon.

17. The apparatus as defined in claim 11 wherein said upwardly inclined body of water having sufficient depth to permit skimming maneuvers thereon, and wherein said upwardly inclined surface of water having sufficient width and length to permit water skimming maneuvers thereon.

18. The apparatus as defined in claim 12 wherein said upwardly inclined body of water and said horizontal body of water having sufficient depth to permit water skimming maneuvers thereon, and wherein said upwardly inclined surface of water and said horizontal surface of water having sufficient width and length to permit water skimming maneuvers thereon.

19. The apparatus as defined in claim 13 wherein said upwardly inclined body of water and said horizontal body of water and said downwardly inclined body of water having sufficient depth to permit water skimming maneuvers thereon, and wherein said upwardly inclined surface of water and said horizontal surface of water and said downwardly inclined surface of water having sufficient width and length to permit water skimming maneuvers thereon.

20. An apparatus for forming a stably-shaped body of water with a surface thereon, comprising:

means for forming a downwardly inclined body of water with a downwardly inclined surface thereon; said downwardly inclined body of water moving over said downwardly inclined forming means with a downward velocity, wherein said downwardly inclined body of water has a shape and dimensions thereof that are substantially stable with respect to time;

means for forming a downstream upwardly inclined body of water with an upwardly inclined surface thereon;

said upwardly inclined body of water moving over said upwardly inclined forming means with a first upwardly inclined velocity, wherein said upwardly inclined body of water has a shape and dimension thereof that is substantially stable with respect to time;

said upwardly inclined body of water and said upwardly inclined surface having a downstream slope sufficient to permit an object floating by condition of motion thereon to slide down said slope with a second velocity, relative to said first upwardly inclined velocity, at least as great as the negative of said first upwardly inclined velocity; and

means for interconnecting said means for forming said downwardly inclined body of water with said means for forming said upwardly inclined body of water.

21. The apparatus as defined in claim 20 wherein said upwardly inclined body of water having an upwardly inclined surface thereon comprises:

28

an upstream slope insufficient to permit an object floating by condition of motion thereon to slide down said slope;

a downstream slope sufficient to permit an object floating by condition of motion thereon to slide down said slope with said second velocity, relative to said first upwardly inclined velocity, at least as great as the negative of said first upwardly inclined velocity; and

a furthestmost downstream slope sufficient to permit an object floating by condition of motion thereon to slide down said slope with a third velocity, relative to said first upwardly inclined velocity, greater than the negative of said first upwardly inclined velocity.

22. The apparatus as defined in claim 20 wherein a means for forming a horizontal body of water is located adjacent and between said means for forming said downwardly inclined body of water and said means for forming said upwardly inclined body of water, wherein said upwardly inclined body of water and said horizontal body of water have sufficient depth to permit surfing maneuvers thereon, and wherein said upwardly inclined surface of water and said horizontal surface of water have sufficient width and length to permit surfing maneuvers thereon.

23. The apparatus as defined in claim 20 further comprising a means for forming a horizontal body of water located adjacent and between said means for forming said downwardly inclined body of water and said means for forming said upwardly inclined body of water, wherein said upwardly inclined body of water and said horizontal body of water and said downwardly inclined body of water have sufficient depth to permit water skimming maneuvers thereon, and wherein said upwardly inclined surface of water and said horizontal surface of water have sufficient width and length to permit water skimming maneuvers thereon.

24. An amusement apparatus for water sports activities using a body of water flowing in a predetermined direction comprising:

means for forming an upwardly inclined body of water, said inclined body of water having an upwardly inclined surface thereon;

said forming means having a tunnel wave forming area thereon, said tunnel wave forming area comprising:

a predominantly concave curvature in sections both parallel and normal to the horizontal;

a face positioned, as a whole, in a direction angularly displaced with respect to the direction of water flow of said upwardly inclined body of water and having:

an inclination with respect to the horizontal; and an attitude with respect to the direction of water flow;

said face facing predominantly, at any given point, in a direction tangential to the direction of water flow of said upwardly inclined body of water, whereby said body of water conforms to said concave curvature;

a down stream terminus such that the angle of release for said upwardly inclined body of water defines an acute angle with respect to the horizontal; and

5,236,280

29

said attitude being greater than ninety degrees and less than parallel with respect to said direction of water flow;

a source of water for providing said body of water, said body of water having:

a depth sufficient to allow water skimming maneuvers thereon;

a velocity which is at least super critical; and

a momentum transfer sufficient to support a user on said surface while performing water skimming maneuvers thereon.

25. An amusement apparatus for water sports activities using a body of water flowing in a predetermined direction comprised of:

means for forming a body of water, wherein a portion of said forming means forms an upwardly inclined body of water having an upwardly inclined surface thereon;

said forming means having a tunnel wave forming area thereon, said tunnel wave forming area comprising:

a predominantly concave curvature in sections both parallel and normal to the horizontal;

a face positioned, as a whole, in a direction angularly displaced with respect to the direction of water flow of said upwardly inclined body of water and having;

an inclination with respect to the horizontal; and

an attitude with respect to the direction of water flow;

said face facing predominantly, at any given point, in a direction tangential to the direction of water flow of said upwardly inclined body of water, whereby said body of water conforms to said concave curvature;

a down stream terminus such that the angle of release for said upwardly inclined body of water defines an acute angle with respect to the horizontal; and

said attitude being greater than ninety degrees and less than parallel with respect to said direction of water flow;

said upwardly inclined surface forming area comprising:

an upstream surface having an upwardly concave curvature with respect to the horizontal;

an upward incline extending from said upstream surface;

a downstream surface having a convex curvature in sections normal to the horizontal and from an upward incline towards the horizontal;

said downstream surface being at an angle from the horizontal;

said downstream surface having an elevated side and a non-elevated side;

said elevated side being adjacent said tunnel wave forming area;

a face positioned, as a whole, in a direction obtuse to the direction of water flow of said upwardly inclined body of water and having;

an inclination with respect to the horizontal; and

an attitude with respect to the flow direction;

said face facing predominantly, at any given point, in a direction tangential to the direction of water flow of said upwardly inclined body of water;

a source of water for providing said body of water, said upwardly inclined body of water moving over

30

said forming means with a range of velocity and volume to a pre-determined maximum;

said upwardly inclined body of water:

having shape and dimension thereof proportional to pre-determined velocity and volume ratios;

at a minimum, having a shape and dimensions thereof that are substantially stable with respect to time at said non-elevated side and having white water breaking region maintained upstream and of said elevated side;

at a maximum, having a shape and dimensions thereof from said non-elevated side to said elevated side substantially stable with respect to time;

said water of said inclined body of water:

having a minimum, velocity and volume sufficient to form, over a period of time, an inclined body of water that at least flows over said non-elevated side and flows upon a portion of said tunnel wave area to form a spilling white water breaking region;

having a maximum, velocity and volume sufficient to form an inclined body of water that flows over said non-elevated side and flows over said elevated side and over said tunnel wave area to form a tunnel wave.

26. A method of increasing speed during use of an amusement water ride comprising:

providing a continuous flow of water having an equilibrium area sandwiched between a sub-equidyne area and a supra-equidyne area with flow being from said sub-equidyne area to said supra-equidyne area;

positioning said sub-equidyne area as the lowest area of said flow of water; and

proportioning said sub-equidyne area, said supra-equidyne area and said equilibrium area so that a rider on said water flow may oscillate between a position on said supra-equidyne area through said equilibrium area to said sub-equidyne area and by extending himself accelerates and may return toward said supra-equidyne area at an increased speed.

27. The apparatus as defined in claim 1 wherein said upwardly inclined body of water and said horizontal body of water have sufficient depth to permit surfing and water skimming maneuvers thereon.

28. The apparatus as defined in claim 1 wherein said upwardly inclined surface of water and said horizontal surface of water have sufficient width and length to permit surfing and water skimming maneuvers thereon.

29. A water ride facility wherein the user rides on a flowing body of water, said facility comprising:

a riding surface comprising an inclined portion and an adjacent downstream wave-forming structure elevated above said inclined portion;

means for forming a shallow flow of water at a supercritical velocity on said riding surface, said shallow flow of water flowing up said inclined portion and on said wave-forming structure to form a simulated wave, wherein said user riding on said shallow flow of water utilizes the force of gravity and the momentum of said flow of water to perform water skimming maneuvers thereon; and

said shallow flow of water having a minimal depth and a supercritical velocity sufficient to cause said shallow flow of water to traverse at least a portion

5,236,280

31

of said elevated wave-forming structure, thereby forming said simulated wave without experiencing a drop in velocity to less than a supercritical velocity at said portion, wherein said minimal depth serves to minimize the energy consumption of said water ride facility and helps prevent said user from drowning.

30. The water ride facility of claim 29, wherein the

32

depth of said shallow flow of water ranges between 2 and 40 cm.

31. The water ride facility of claim 29, wherein said wave-forming structure is concave, whereby a tunnel wave is formed.

• • • • •

10

15

20

25

30

35

40

45

50

55

60

65



US005393170A

**United States Patent** [19]

[11] **Patent Number:** 5,393,170

**Lochtefeld**

[45] **Date of Patent:** Feb. 28, 1995

- [54] **METHOD AND APPARATUS FOR IMPROVING SHEET FLOW WATER RIDES**
- [76] **Inventor:** Thomas J. Lochtefeld, 5508 Pacifica Dr., La Jolla, Calif. 92037
- [21] **Appl. No.:** 74,300
- [22] **Filed:** Jun. 9, 1993

4,805,897 2/1989 Dubeta .

*Primary Examiner*—Dennis L. Taylor  
*Attorney, Agent, or Firm*—Knobbe, Martens, Olson & Bear

**Related U.S. Application Data**

- [63] Continuation of Ser. No. 577,741, Sep. 4, 1990, Pat. No. 5,236,280, which is a continuation-in-part of Ser. No. 286,964, Dec. 19, 1988, Pat. No. 4,954,014, which is a continuation-in-part of Ser. No. 54,521, May 27, 1987, Pat. No. 4,792,260.
- [51] **Int. Cl.<sup>6</sup>** ..... A63B 69/00
- [52] **U.S. Cl.** ..... 405/79; 4/491; 472/13
- [58] **Field of Search** ..... 405/79, 80, 52; 4/491; 472/13

[57] **ABSTRACT**

An amusement apparatus for water sports activities wherein a flowing body of water is provided. The water moves across an inclined, declined or horizontal riding surface upon which the velocity, volume and gravitational dynamics of the flowing body of water is such that a rider may perform water skimming/simulated surfing maneuvers thereon. Composite structures with horizontal and inclined surfaces and varying flow velocity over time across specifically shaped structures permit water skimming/simulated surfing maneuvers on unbroken, spilling or tunnel type wave forms. Asymmetry in the downstream ridge line of an inclined surface allows spilling type wave formations as well as facilitating the removal of a transient surge. A novel fluid "half-pipe" waveform is also introduced.

- [56] **References Cited**  
**U.S. PATENT DOCUMENTS**  
 4,792,260 12/1988 Sauerbier ..... 405/79

**32 Claims, 19 Drawing Sheets**

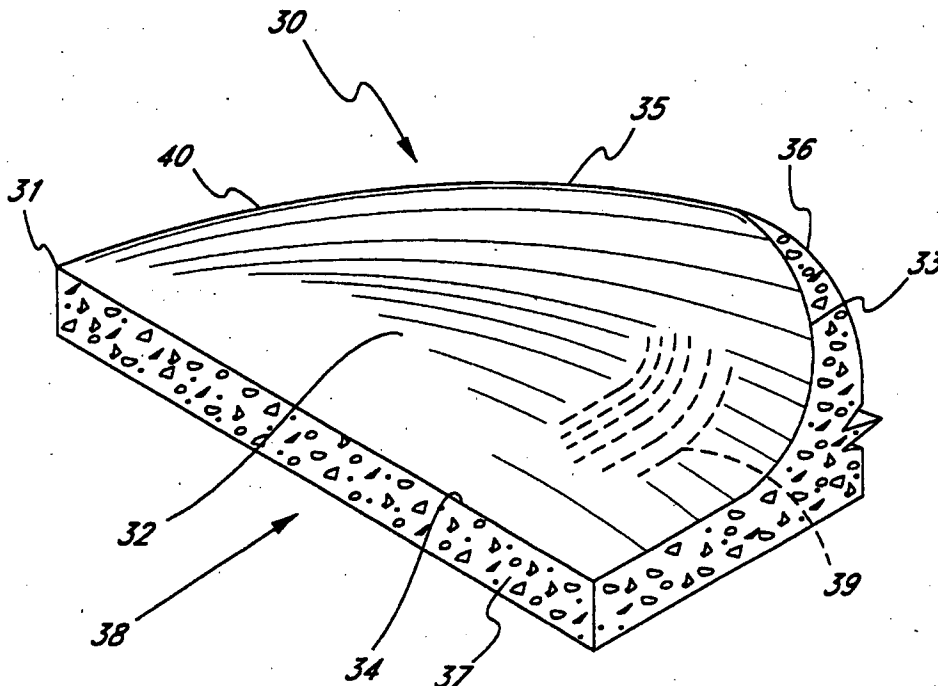

U.S. Patent

Feb. 28, 1995

Sheet 1 of 19

5,393,170

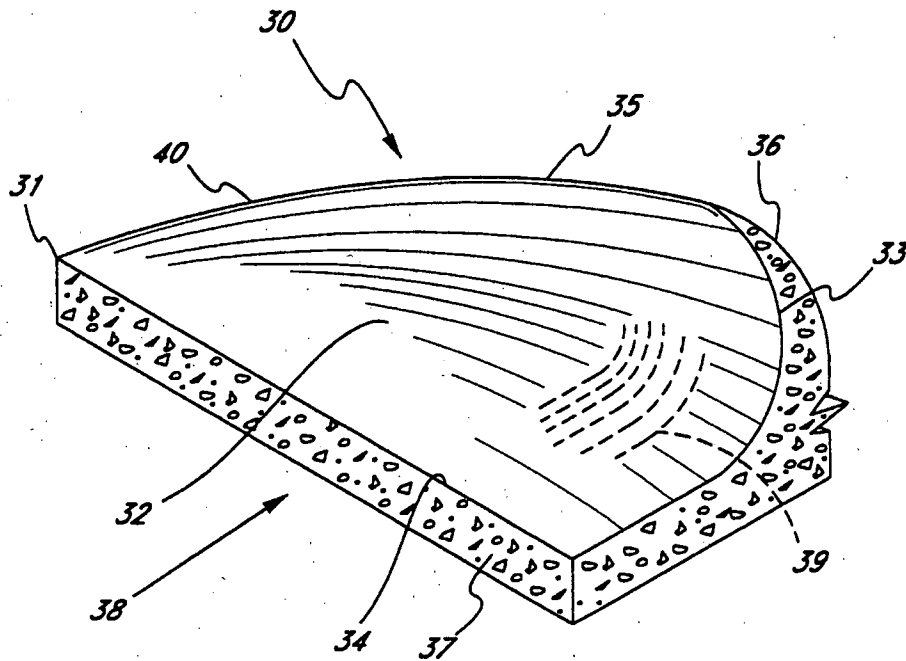

FIG. 1

U.S. Patent

Feb. 28, 1995

Sheet 2 of 19

5,393,170

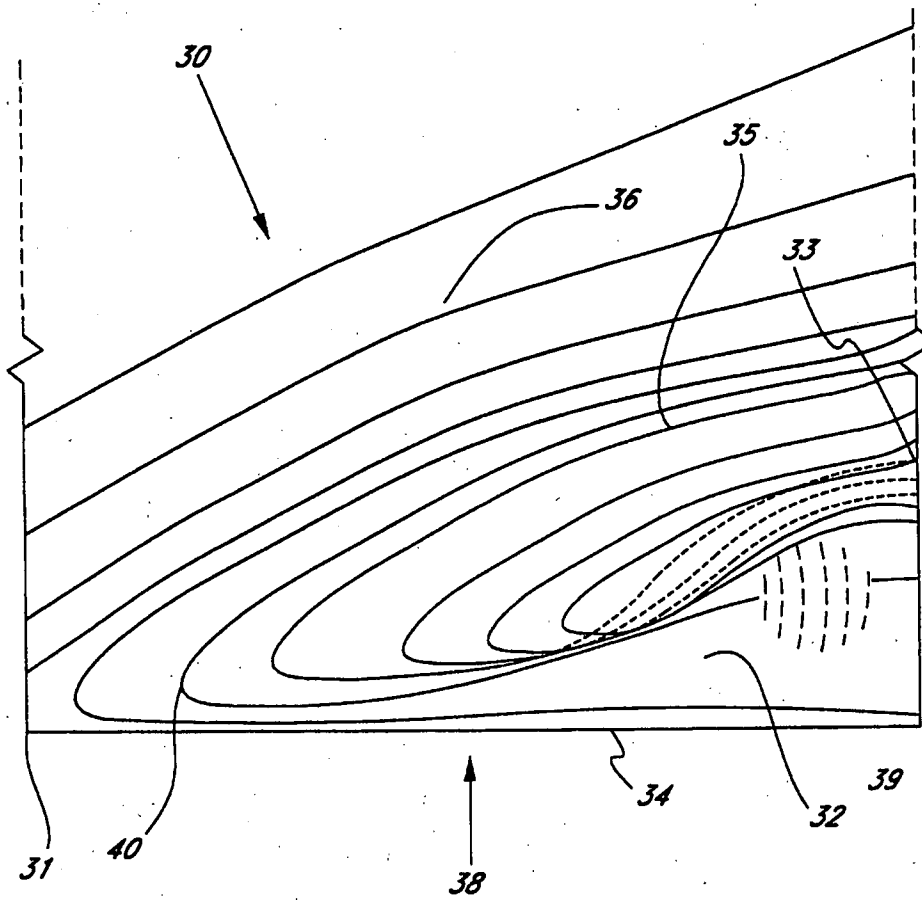

FIG. 2

U.S. Patent

Feb. 28, 1995

Sheet 3 of 19

5,393,170

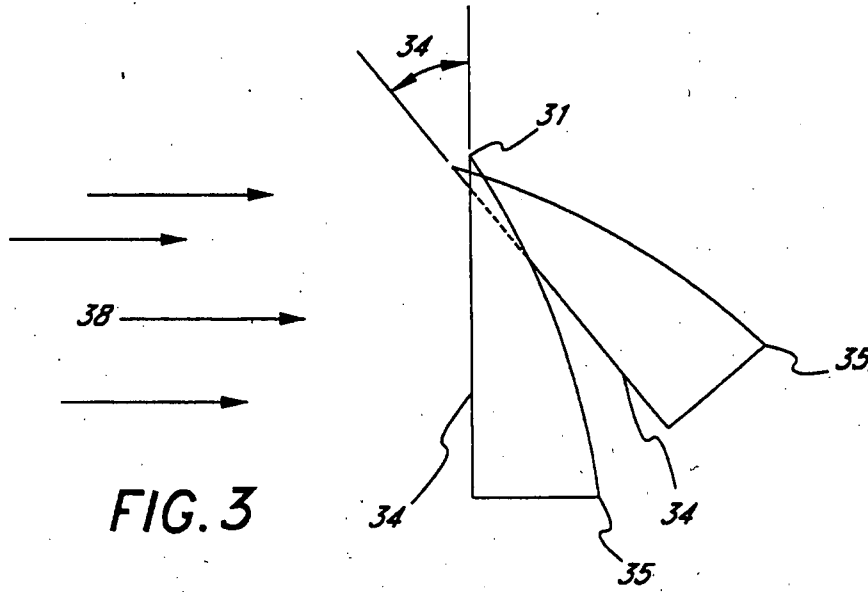

FIG. 3

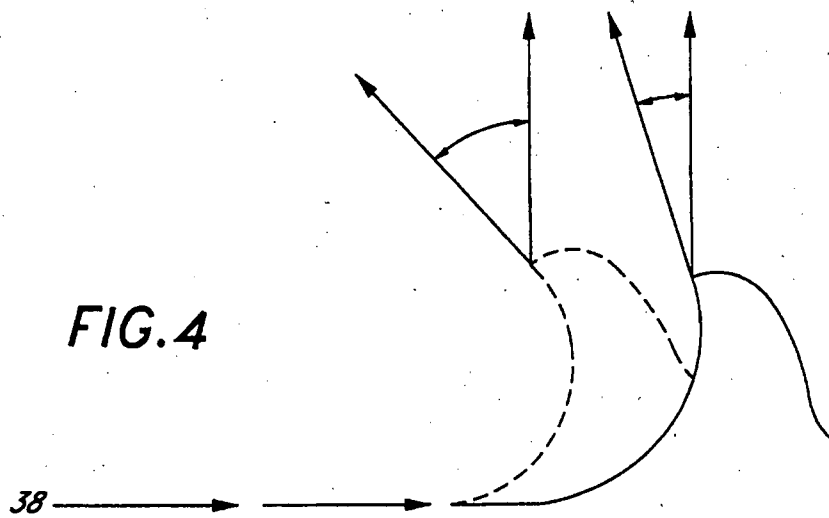

FIG. 4

U.S. Patent

Feb. 28, 1995

Sheet 4 of 19

5,393,170

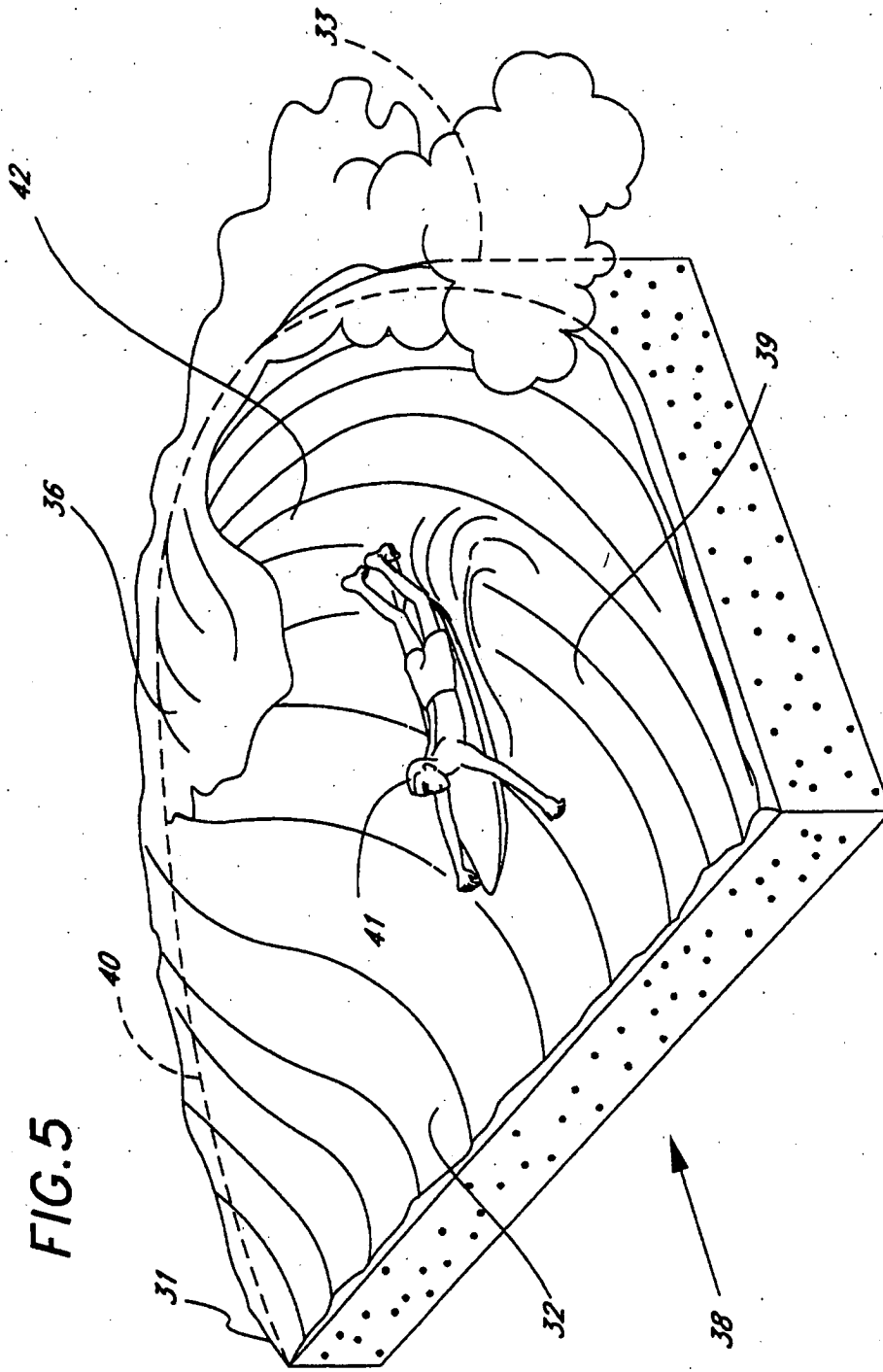

FIG. 5



U.S. Patent

Feb. 28, 1995

Sheet 5 of 19

5,393,170

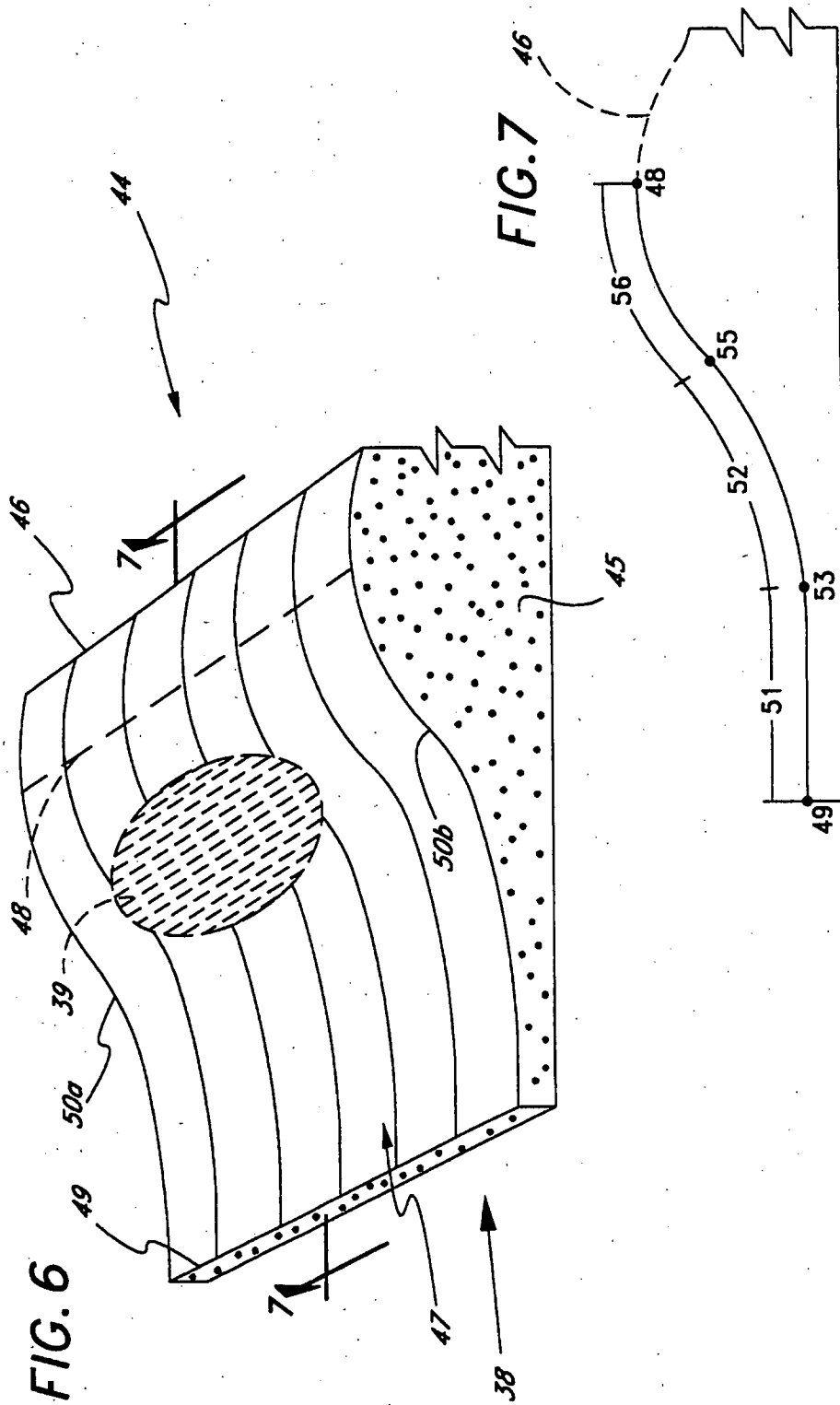

FIG. 6

FIG. 7

U.S. Patent

Feb. 28, 1995

Sheet 6 of 19

5,393,170

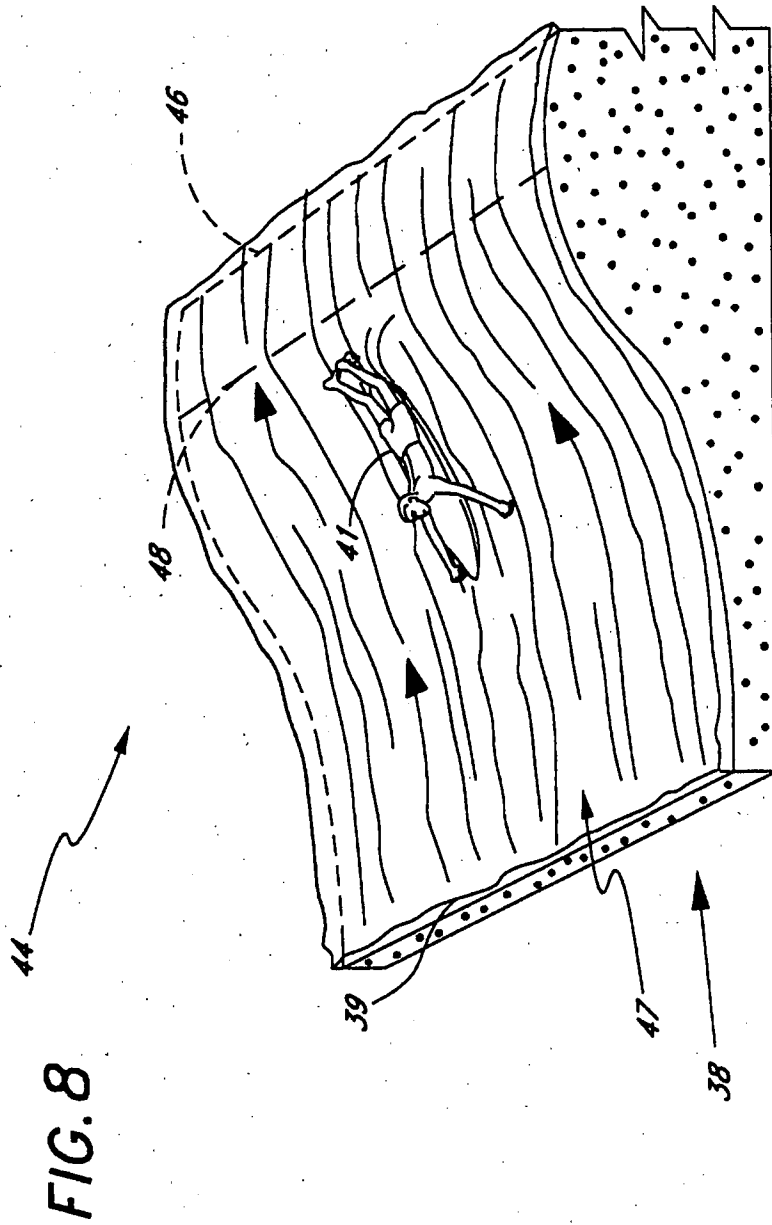

U.S. Patent

Feb. 28, 1995

Sheet 7 of 19

5,393,170

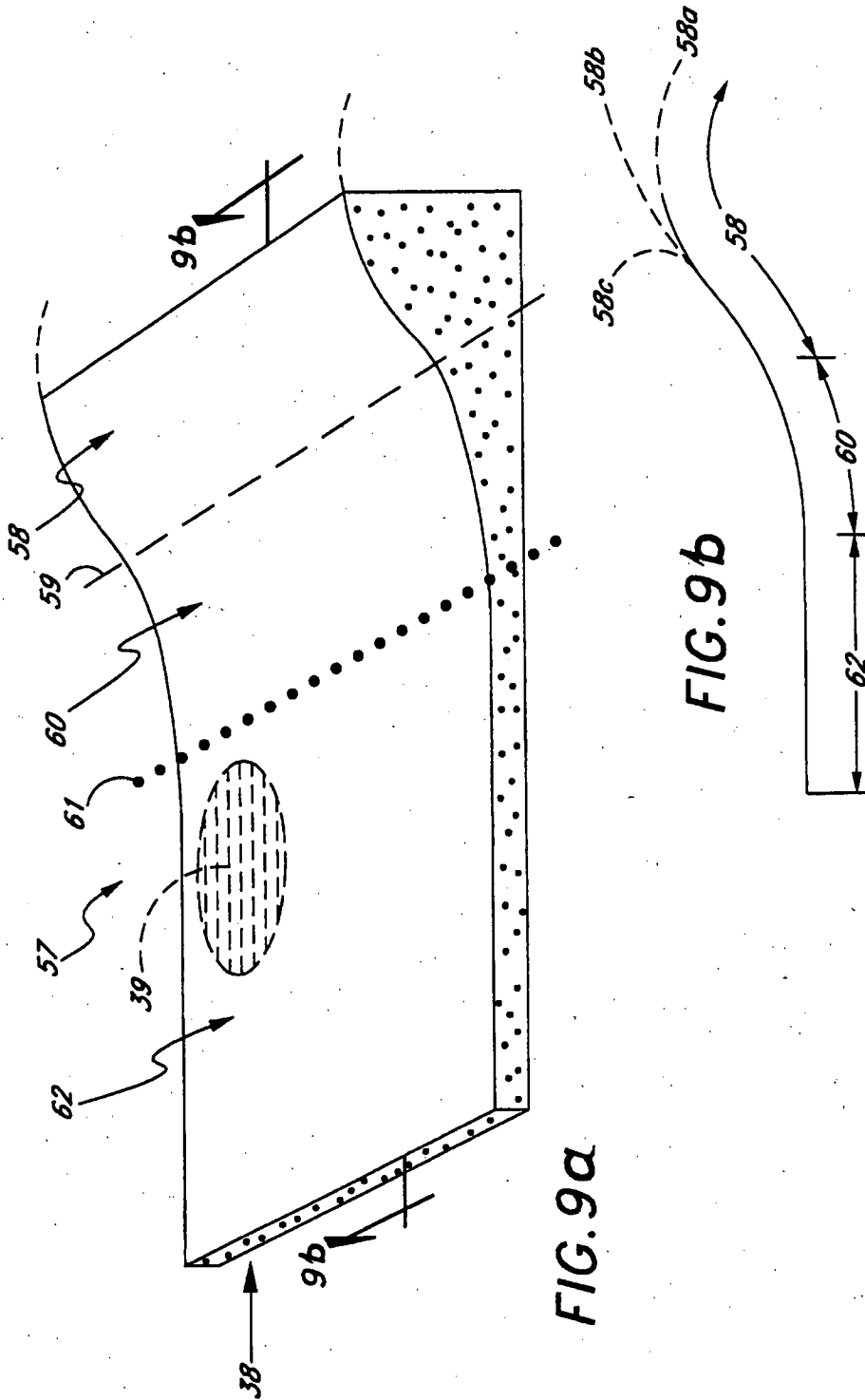

FIG. 9a

FIG. 9b

U.S. Patent

Feb. 28, 1995

Sheet 8 of 19

5,393,170

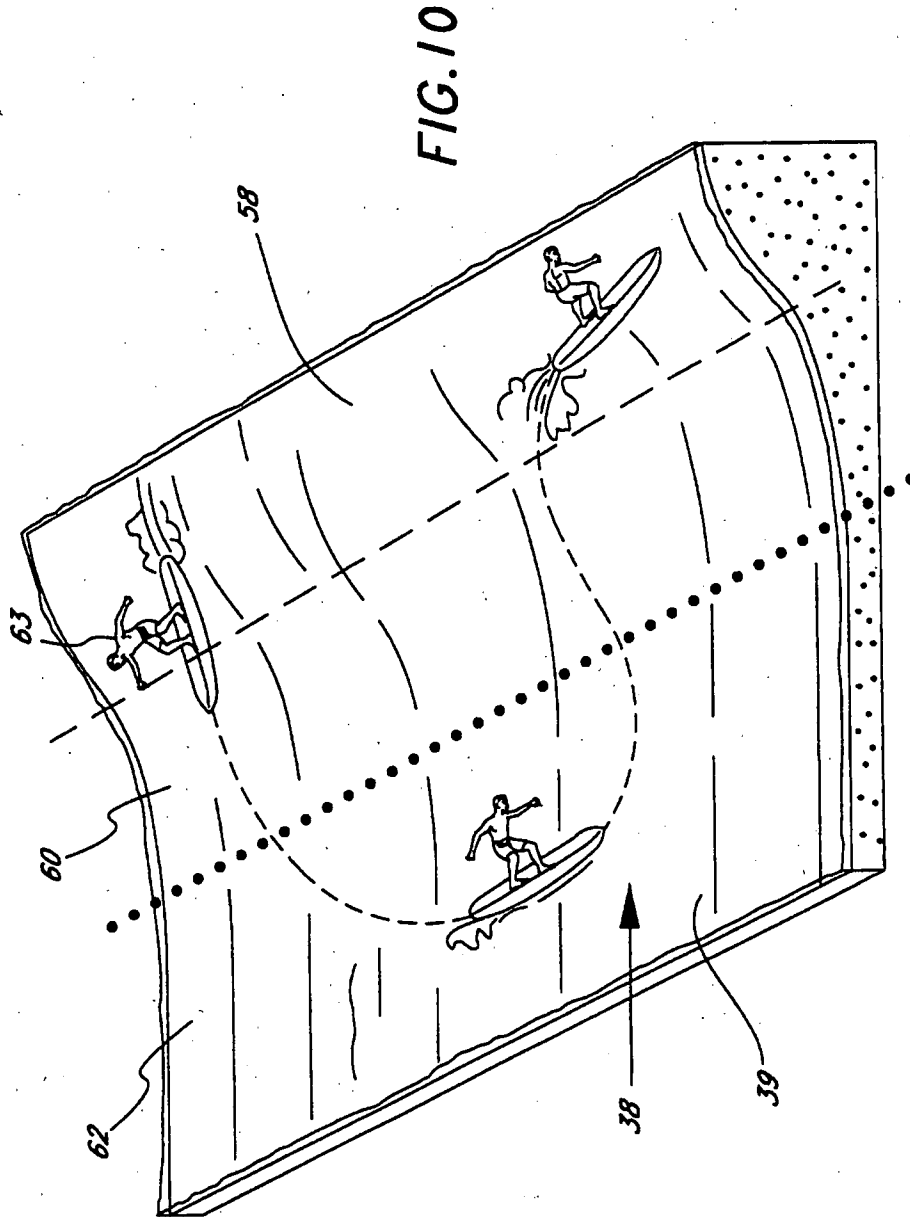

Exhibit 2

U.S. Patent

Feb. 28, 1995

Sheet 9 of 19

5,393,170

FIG. 11a

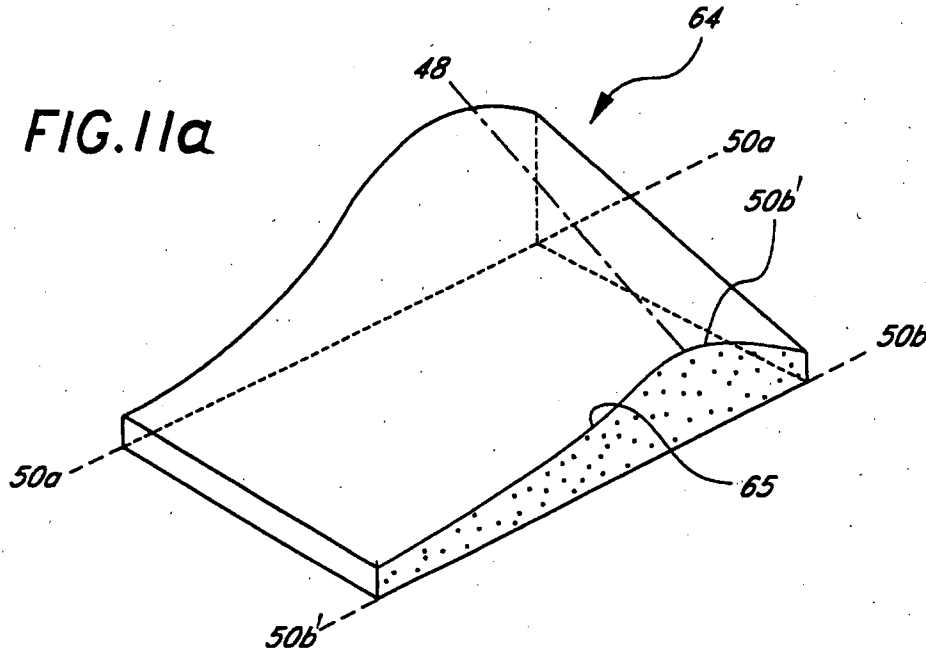
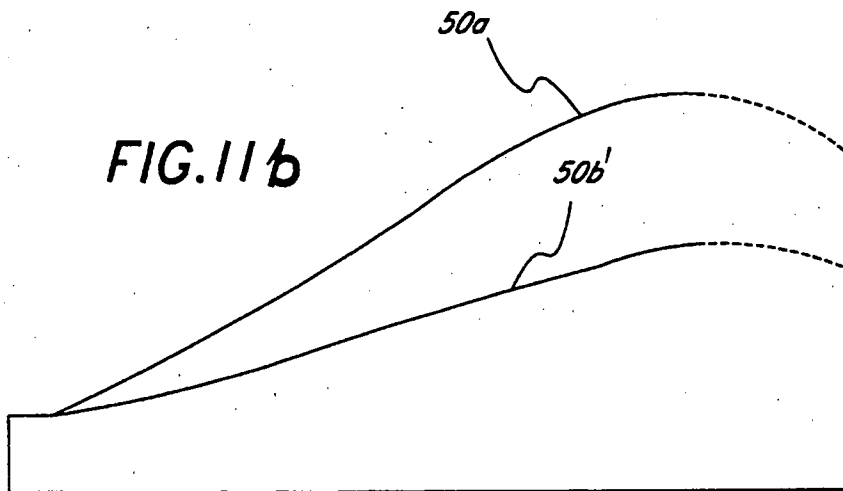

FIG. 11b



U.S. Patent

Feb. 28, 1995

Sheet 10 of 19

5,393,170

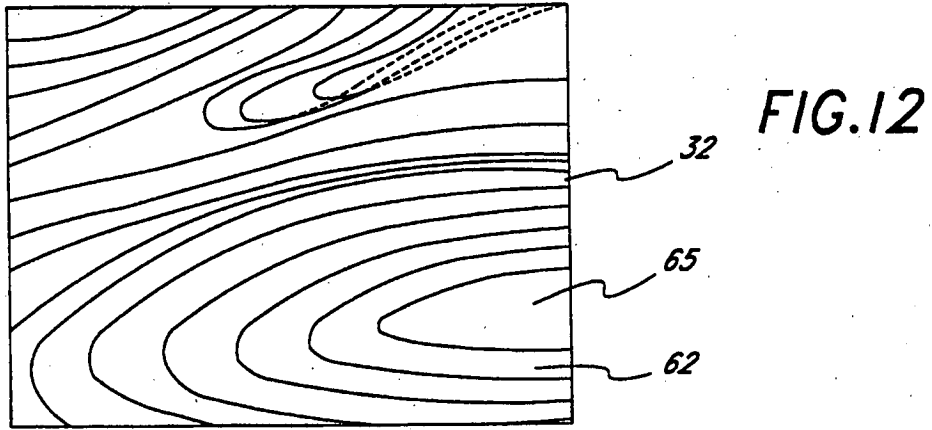

FIG. 14a

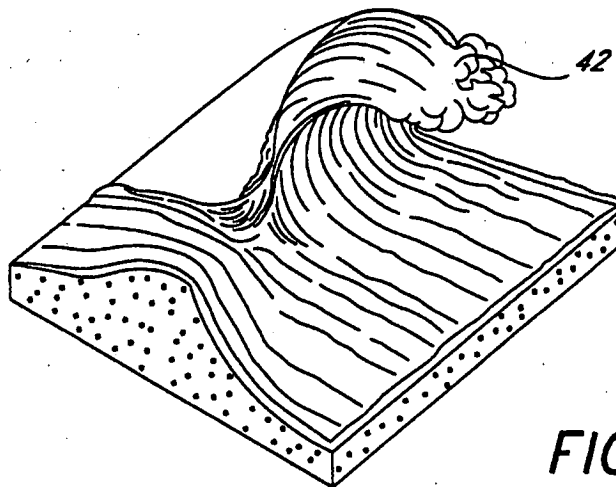
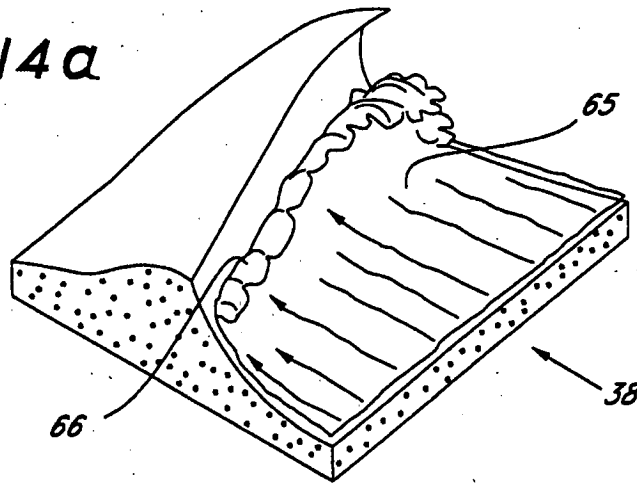

FIG. 14b

U.S. Patent

Feb. 28, 1995

Sheet 11 of 19

5,393,170

FIG. 13a

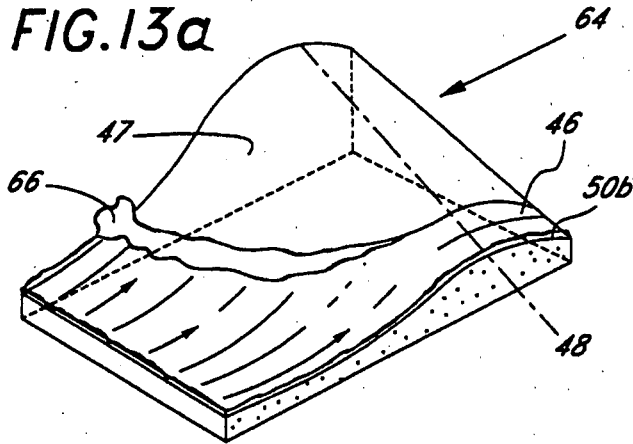

FIG. 13b

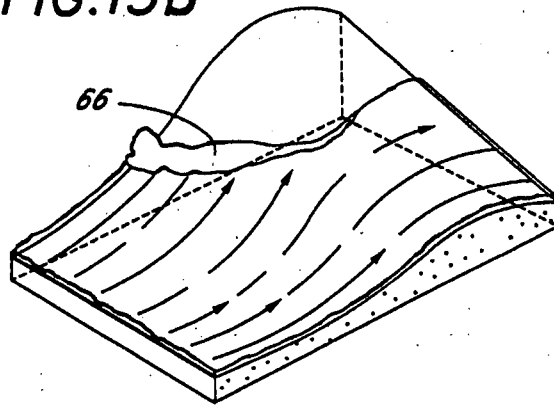
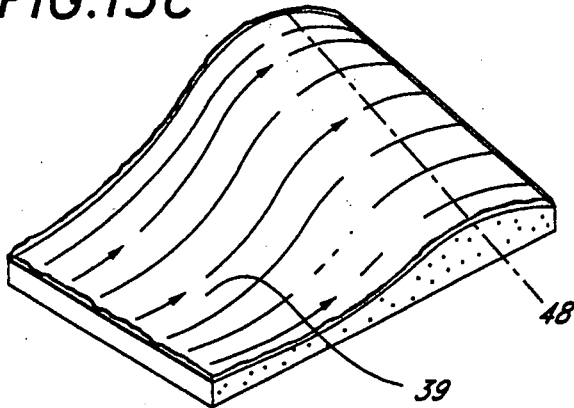

FIG. 13c



U.S. Patent

Feb. 28, 1995

Sheet 12 of 19

5,393,170

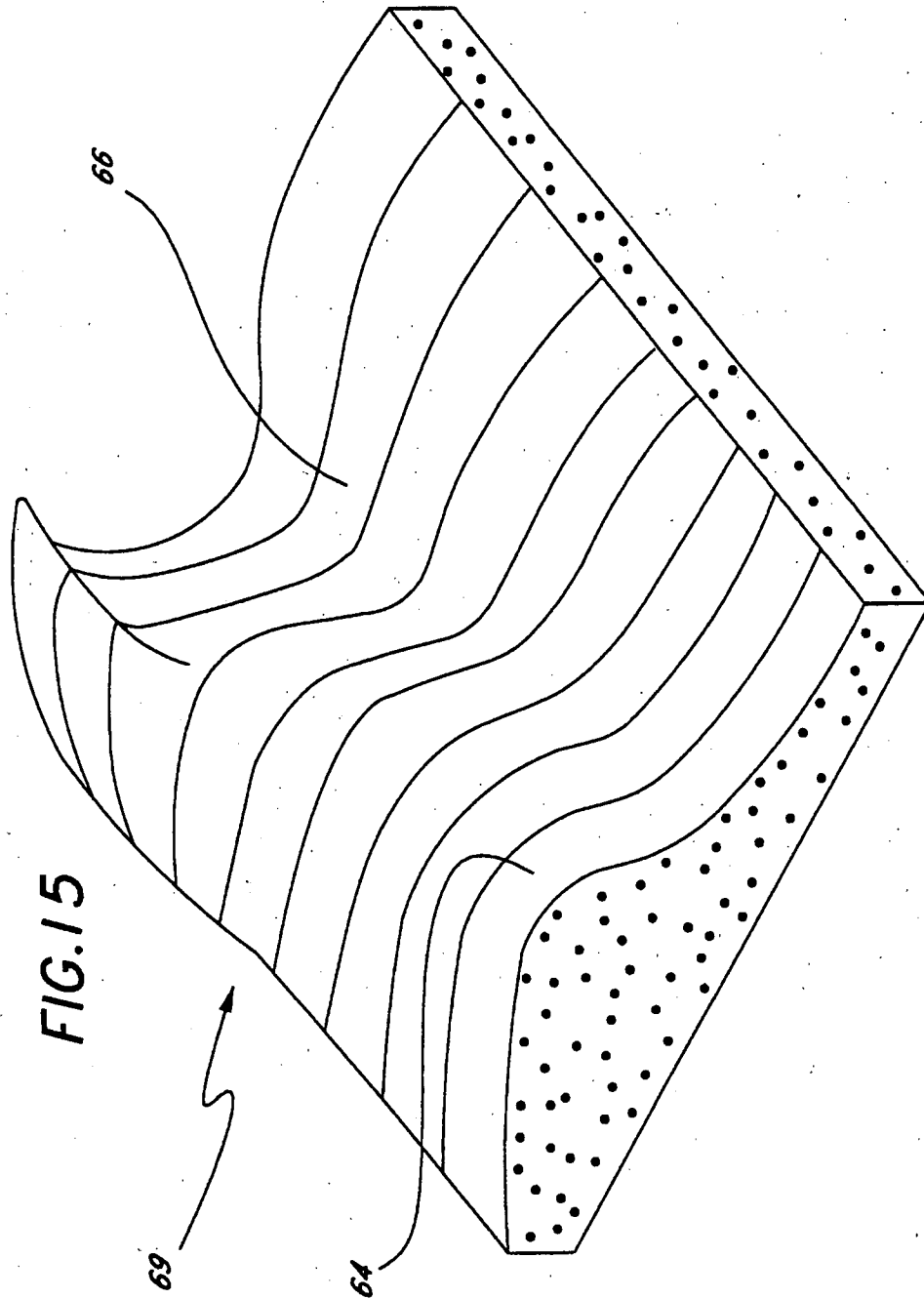

Exhibit 2



U.S. Patent

Feb. 28, 1995

Sheet 13 of 19

5,393,170

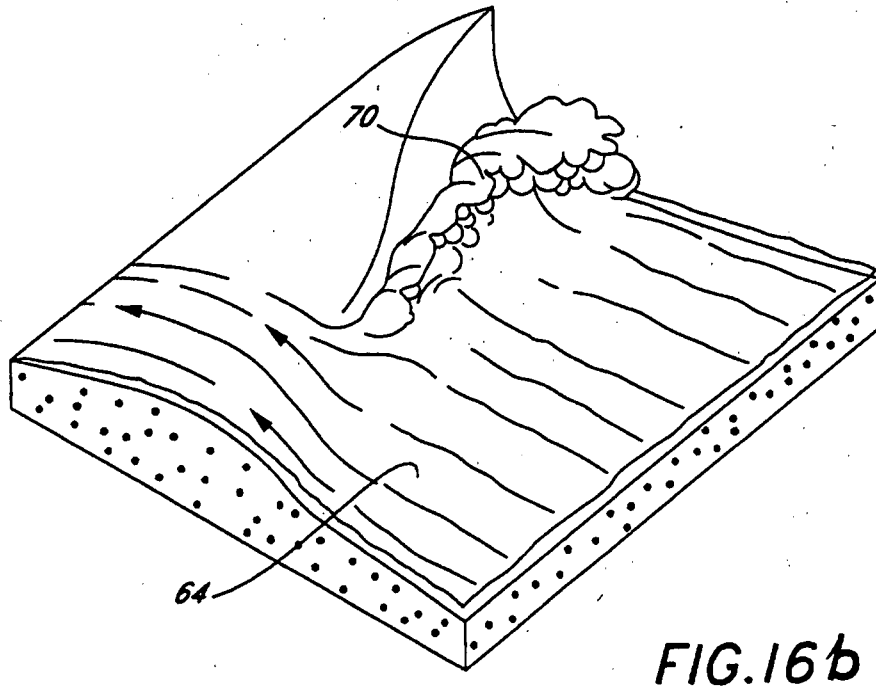
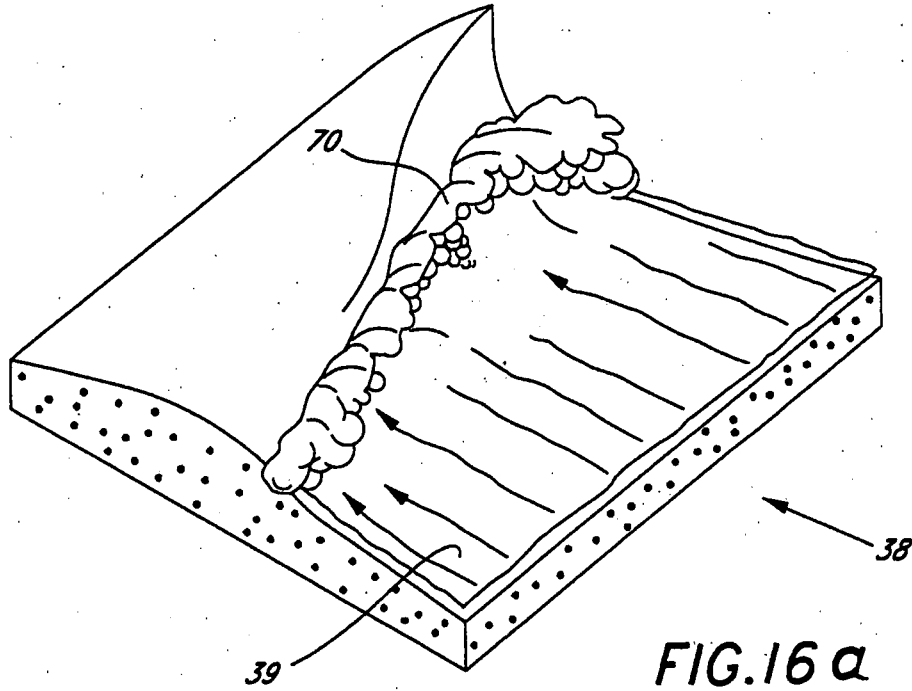

U.S. Patent

Feb. 28, 1995

Sheet 14 of 19

5,393,170

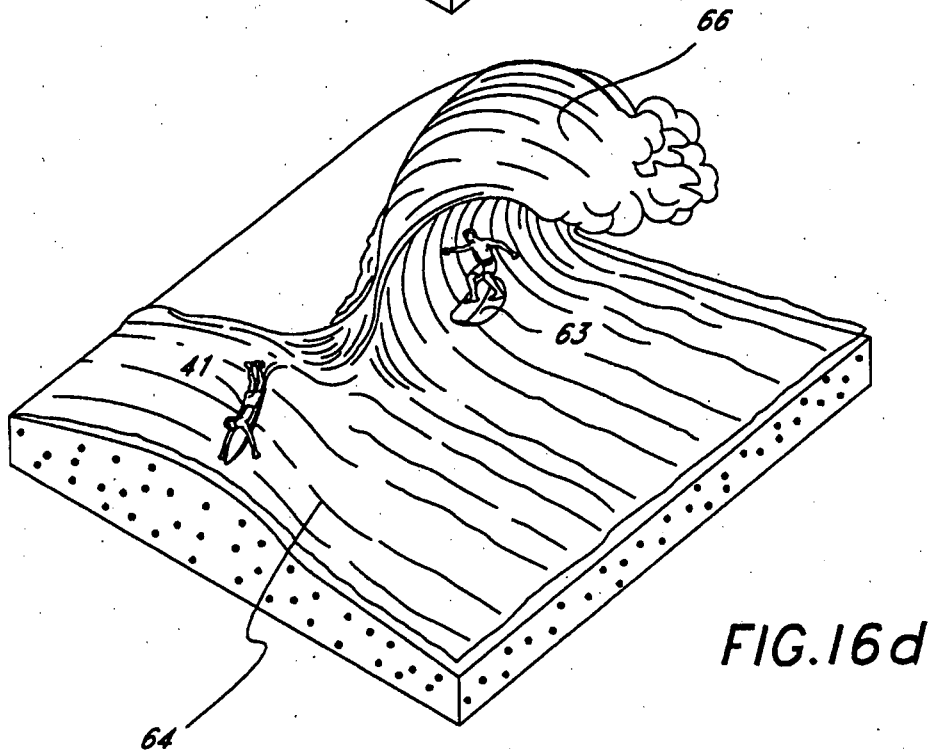
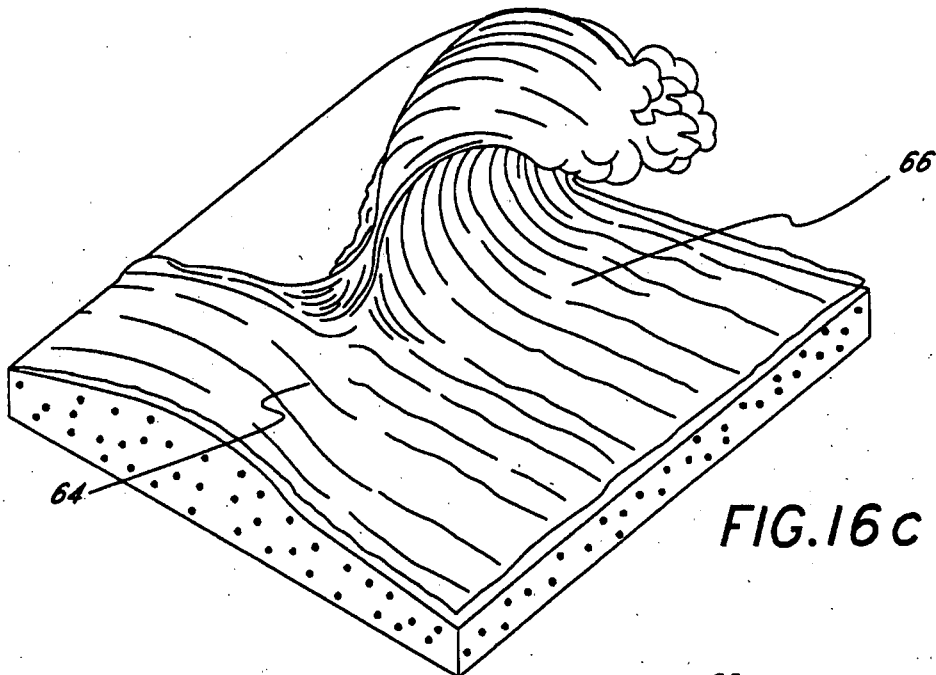

U.S. Patent

Feb. 28, 1995

Sheet 15 of 19

5,393,170

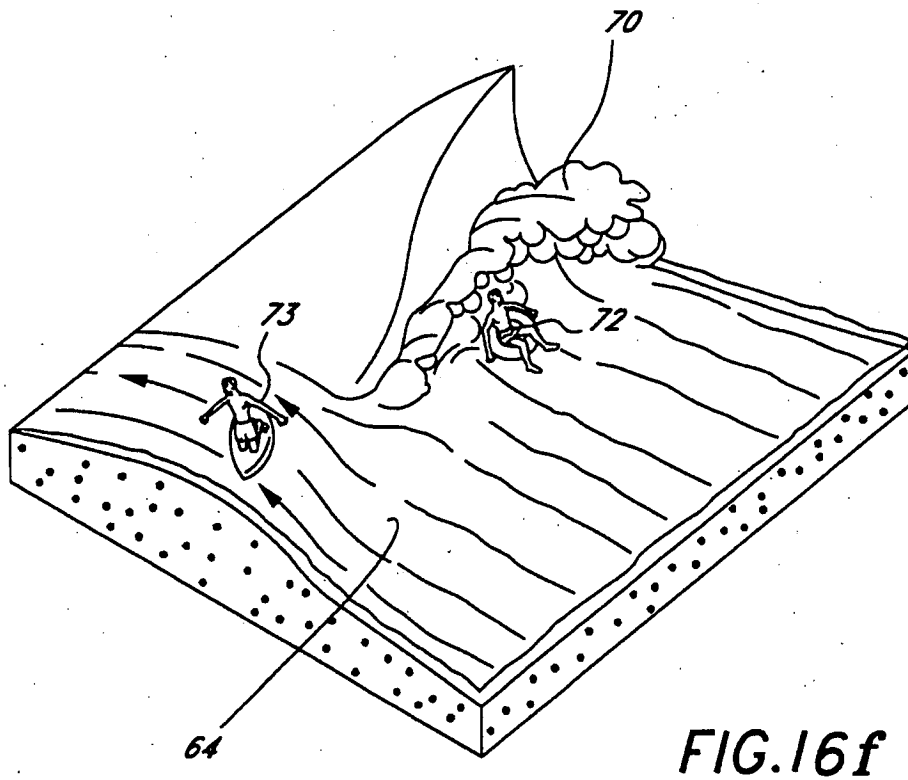
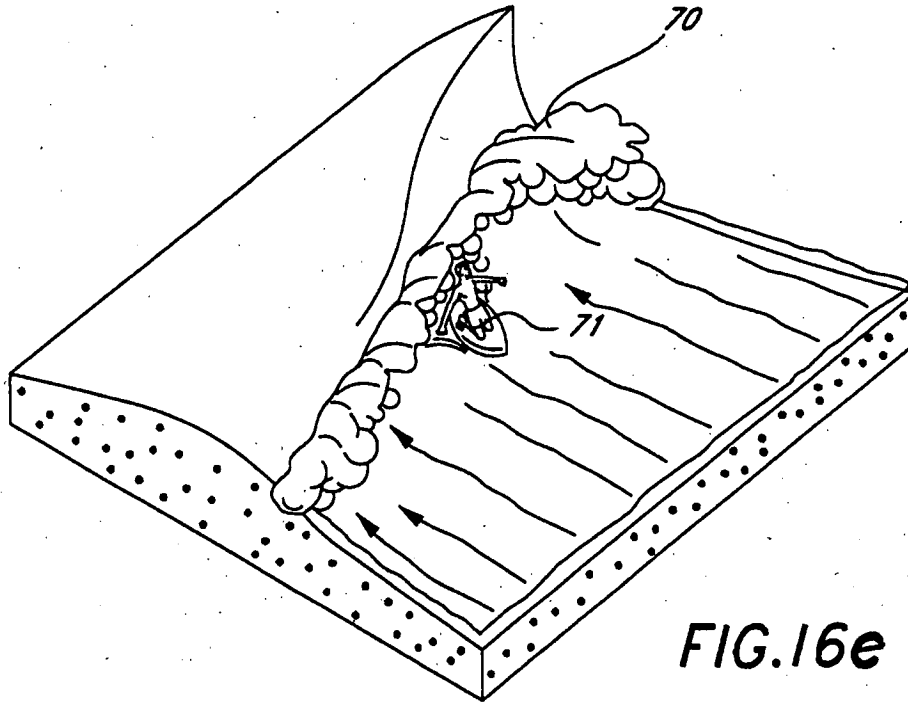

Exhibit 2

U.S. Patent

Feb. 28, 1995

Sheet 16 of 19

5,393,170

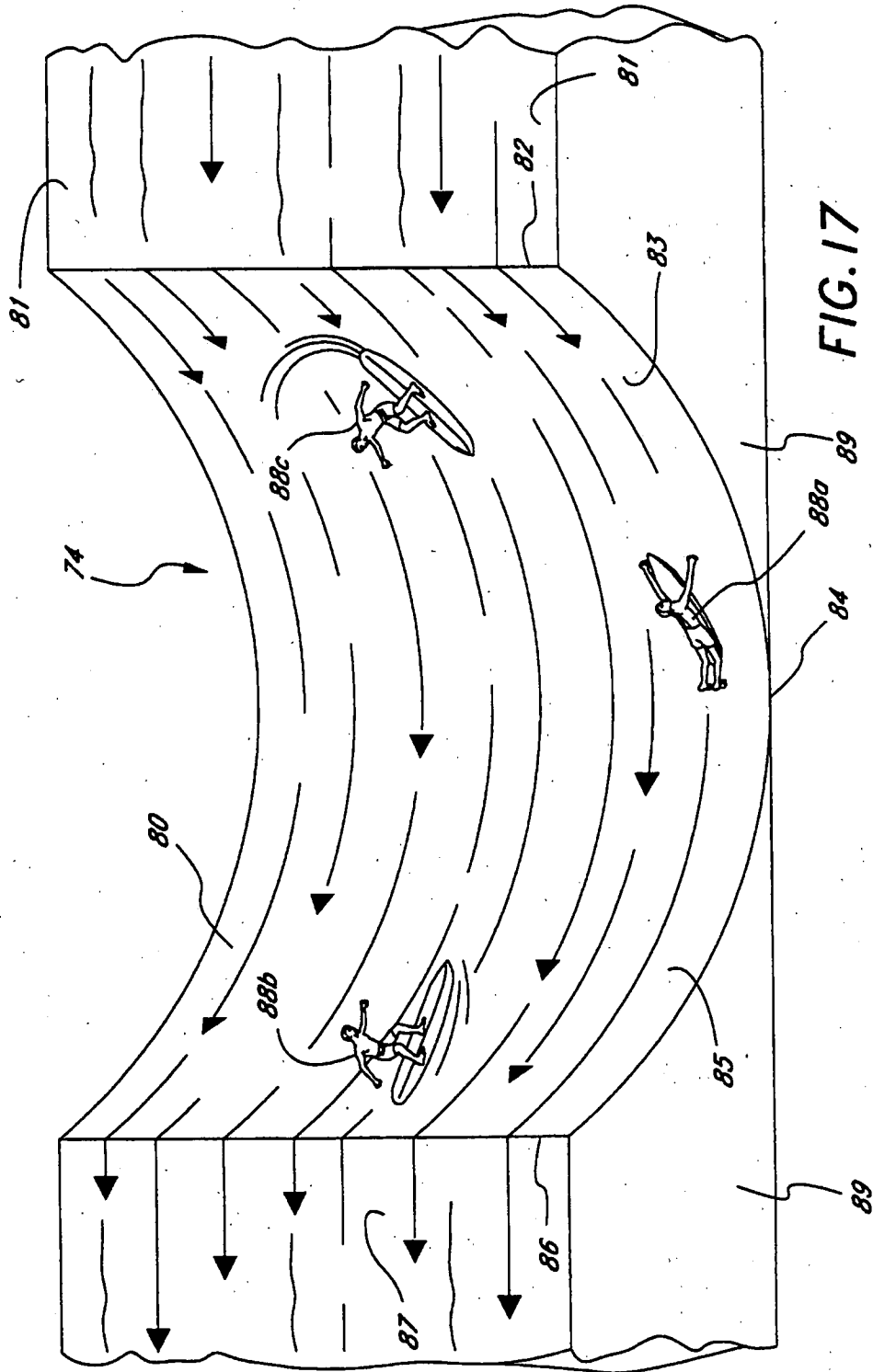

Exhibit 2

U.S. Patent

Feb. 28, 1995

Sheet 17 of 19

5,393,170

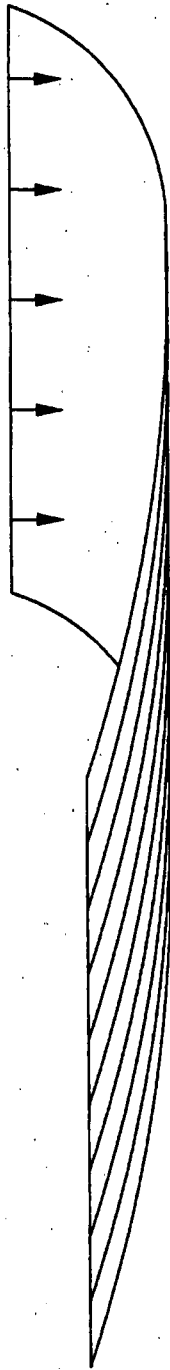

FIG. 18 a

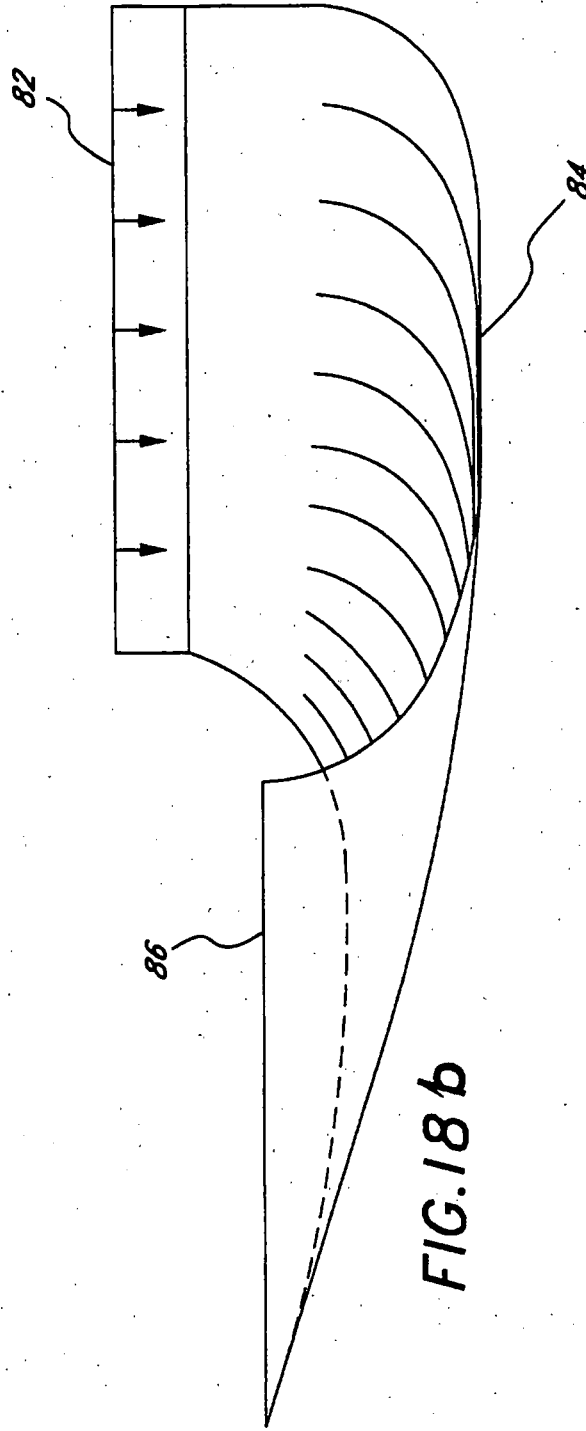

FIG. 18 b

U.S. Patent

Feb. 28, 1995

Sheet 18 of 19

5,393,170

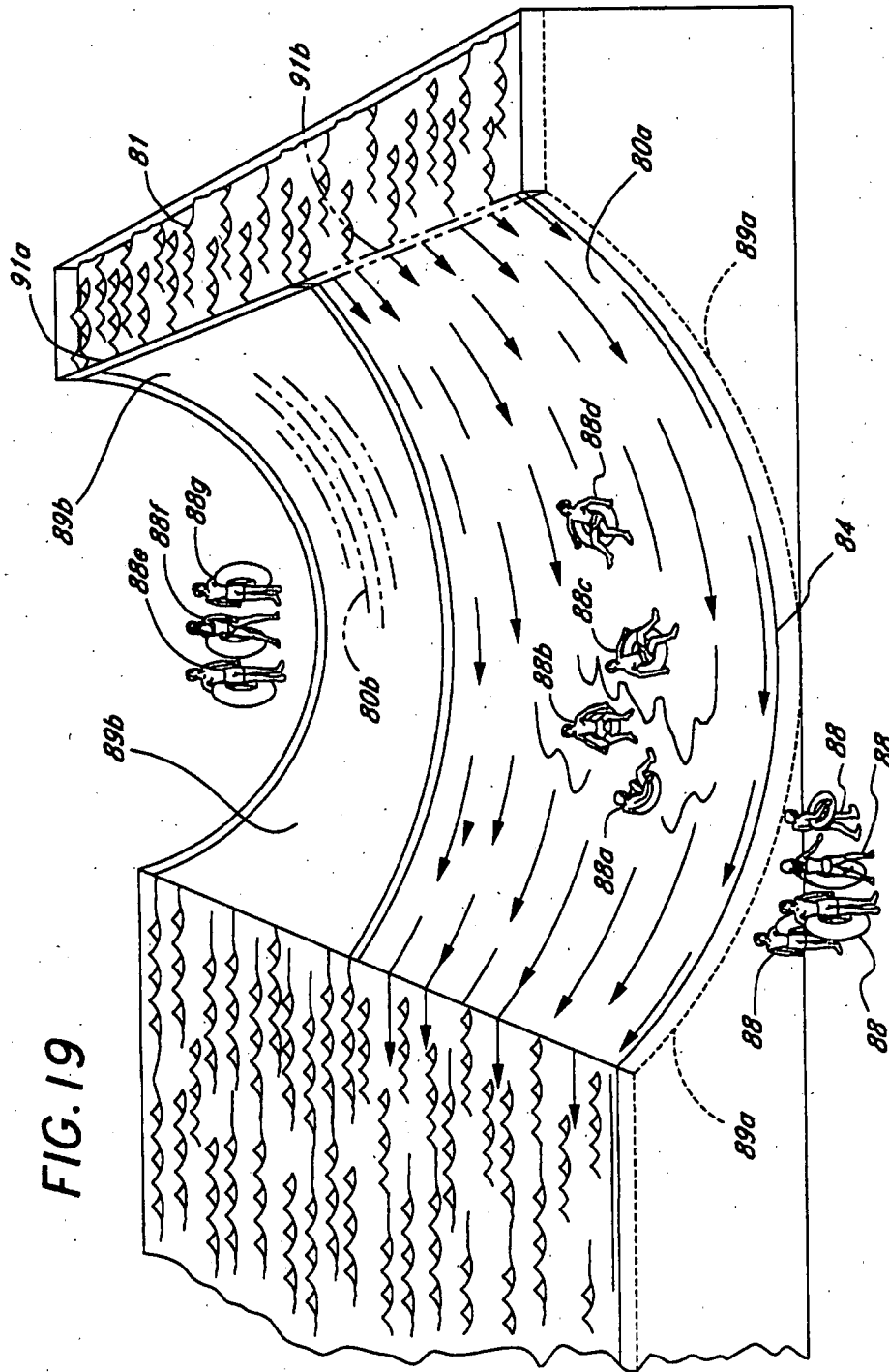

FIG. 19

U.S. Patent

Feb. 28, 1995

Sheet 19 of 19

5,393,170

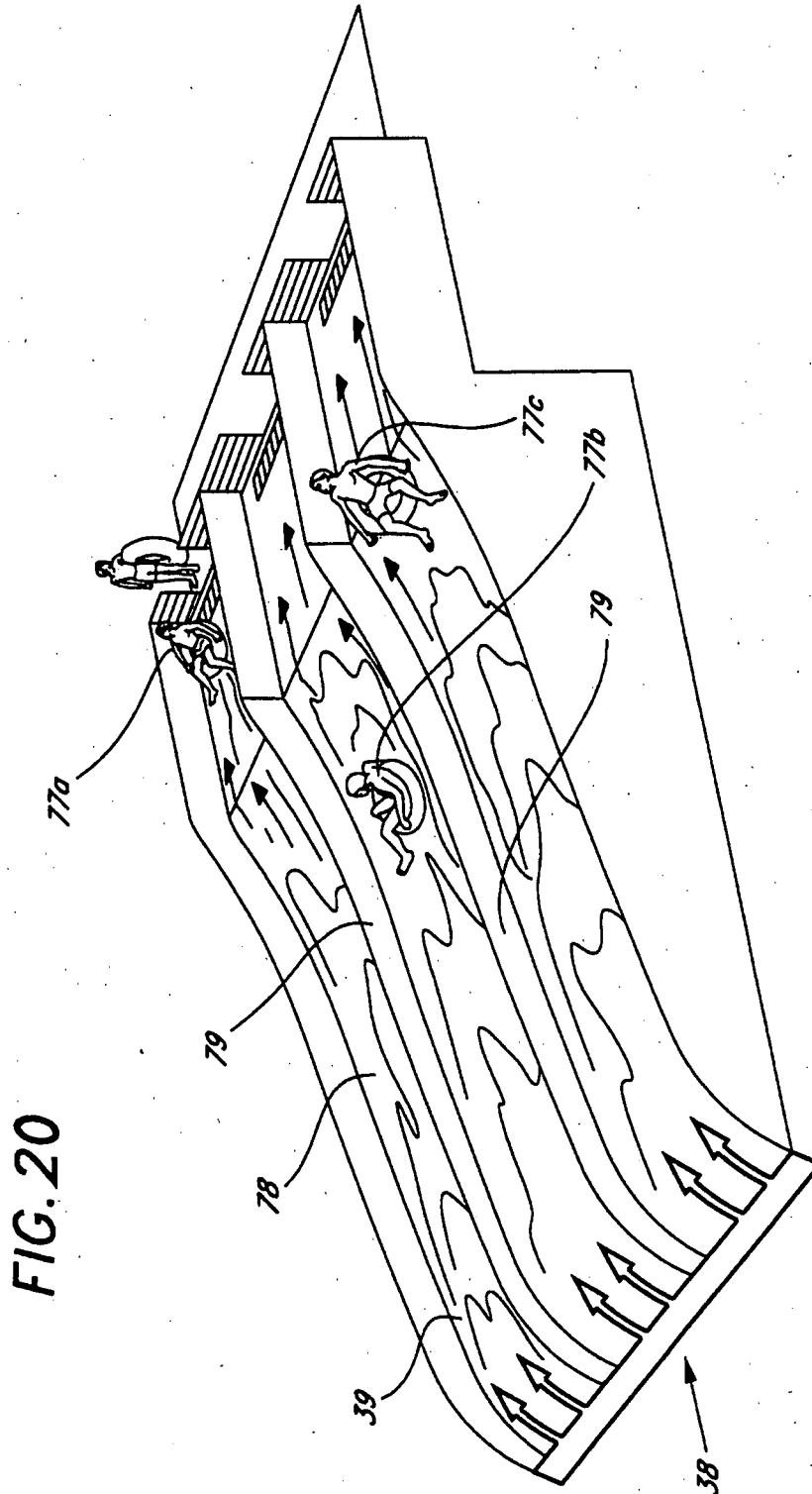

FIG. 20

Exhibit 2

1

## METHOD AND APPARATUS FOR IMPROVING SHEET FLOW WATER RIDES

### RELATED APPLICATIONS

This application is a continuation of application Ser. No. 577,741, filed Sep. 4, 1990, now U.S. Pat. No. 5,236,280, which is a continuation-in-part of U.S. application Ser. No. 07/286,964, filed Dec. 19, 1988, for IMPROVEMENTS IN SURFING-WAVE GENERATORS, issued as U.S. Pat. No. 4,954,014, on Sep. 4, 1990, which is a continuation-in-part of U.S. application Ser. No. 07/054/521, filed May 27, 1987, for TUNNEL WAVE GENERATOR, issued as U.S. Pat. No. 4,792,260, on Dec. 20, 1988.

### FIELD OF THE INVENTION

The present invention relates in general to water rides, specifically a mechanism and process that provides a flowing body of water having flat, radial, and inclined surfaces thereon of sufficient area, depth and slope to permit surfboarding, skim-boarding, body-boarding, inner-tubing, and other water-skimming activity and, in particular, to several embodiments with means for generated, forming, maintaining, moving and riding said flow of water in a predominantly steady state condition.

### BACKGROUND OF THE INVENTION

For the past 25 years, surfboard riding and associated wave riding activities, e.g., knee-boarding, body or "Boogie" boarding, skim-boarding, surf-kayaking, inflatable riding, and body surfing (all hereinafter collectively referred to as wave-riding) have continued to grow in popularity along the world's surf endowed coastal shorelines. In concurrence, the 80's decade has witnessed phenomenal growth in the participatory family water recreation facility, i.e., the waterpark. Large pools with manufactured waves have been an integral component in such waterparks. Several classes of wavepools have successfully evolved. The most popular class is that which enables swimmers or inner-tube/inflatable mat riders to bob and float on the undulating swells generated by the wave apparatus. A few pools exist that provide large turbulent white-water bores that surge from deep to shallow pool end. Such pools enable wave-riding. However, white-water bore riding is not preferred by the cognoscenti of the wave-riding world, rather the forward smooth water face of a curling or tubing wave that runs parallel to the shoreline holds the ultimate appeal. Although numerous attempts have been made to establish wave-riding on curling waves as a viable activity in the commercial waterpark wavepool setting, such attempts have met with limited success. The reasons which underlie wave-riding's limited waterpark success is four-fold, 1) small spilling or unbroken waves which are ideal for the mass of novice waterpark attendees are not ideal for intermediate or advanced wave-riders; 2) the larger waves ideal for wave riding have proven prohibitive in cost to duplicate and become inherently more dangerous as their size increases; 3) the curling and plunging waves sought by advanced wave riders require steep and irregular pool bottom configurations that are inherently dangerous and can cause strong deep water current; 4) assuming a compromised and safer wave shape is acceptable to wave-riding participants, wave-riding is ideally a one-man-to-one-wave event that monopolizes an ex-

5,393,170

2

tended surface area. As a consequence of limited wave quality, excessive cost, potential liability, and large surface area to low rider capacity ratios, wavepools specifically designed for waveriders have proven unjustifiable to water park operators.

All wavepools that currently exist in the waterpark industry and the majority of previously disclosed wave-making inventions attempt to duplicate those types of oscillatory waves found naturally occurring at a beach. For purposes of definition, such waves are hereinafter termed "natural waves". Natural waves also include those found occurring in rivers as caused by submerged obstacles e.g., boulders. As known to those skilled in the art, natural waves have specific characteristics capable of mathematical description as a function of wave length, wave height, period, wave angle, velocity, phase speed, break speed, gravity, free surface water elevation, water depth, etc. Additionally, mathematical descriptions can be provided for a wide range of wave shapes progressing from an unbroken-to-breaking-to broken. Breaking waves, those of most interest to waveriders, are traditionally classified as either spilling, plunging or surging. Broken waves can either be stationary (e.g., a river impacting on an obstacle creating a stationary hydraulic jump), or moving (e.g., an ocean white water surge or bore characterized by rapidly varied unsteady flow). The shape of a breaking wave is primarily a function of a given set of the aforementioned wave characteristics and the contour of the bottom over which the wave is moving. Beginning waveriders prefer the smaller gentle spilling wave produced by a gradually sloped bottom surface. Advanced waveriders prefer the larger plunging breakers that result from a steeply inclined beach. Since there are demographically a greater number of beginning wave-riders and since the wave favored by beginning riders is a product of an inherently safer gentle incline of beach, and since the energy and cost required to produce a small spilling wave is exponentially less that required to produce a large plunging wave, the current genre of wave pools have by necessity and practicality not been suitable for wave-riding by the more advanced wave rider.

The subject invention aims at creating a "wave shape" that can serve to provide those types of "wave shapes" desired by intermediate to advanced riders. Additionally, the subject invention seeks to accomplish such "wave shape" creation at a fraction of the cost and with an improved margin of safety as compared to that required to duplicate the aforementioned intermediate to advanced natural waves. The reason the subject invention can succeed at its goal is that it does not duplicate natural waves, rather, it creates "flow shapes" that are a result of high velocity sheet flow over a suitably shaped forming surface. This concept of sheet flow formation versus natural wave formation is one of two primary distinguishing factors between the subject invention and the prior art.

This second distinguishing factor focuses on the forces that "drive" a wave rider when he is riding a wave. To this end, the subject invention defines two distinct classes of flow shapes, i.e., deep water flow shapes and shallow water flow shapes. A deep water flow shape is where the water depth is sufficient such that boundary layer effects of the sheet flow over the forming surface does not influence the operation of rider or riding vehicle, e.g., surfboard. Deep water flow



5,393,170

3

shapes can, assuming certain flow forming and flow characteristics (e.g., velocity) are met, duplicate naturally occurring waves. A shallow water flow shape is where the water is of such depth that the surface boundary layer effects of the sheet flow over the forming surface influences the operation of rider or riding vehicle, e.g., surfboard. As contemplated by the subject invention, shallow water flow shapes will never duplicate naturally occurring waves, because there are differing forces that come into play when a rider rides a shallow flow. As the result of those differing forces, the operational dynamics of the subject invention require that for shallow flows the average velocity of the water sheeting over the flow forming surface will always exceed the maximum velocity which would be found in a natural wave. To better explain why the shallow water flow velocity must always be greater than that of a deep water flow, and to further expand on the forces involved when a surfer rides an ocean wave or conversely when a "skimmer" rides a shallow water flow, the following examples are given: On a natural wave (a deep water flow environment) a surfer prior to starting a ride begins to move up the slope of the coming wave by primarily the forces of buoyancy. In order to overcome the forces of fluid drag, the surfer commences to paddle and take advantage of the interaction between the forces of buoyancy and gravity to provide a forward component to the surfboard and achieve riding speed. Thereafter, maintenance of a steady state position riding normal to the wave front is a balancing act between on the one hand, the hydrodynamic lift forces on the bottom of the surfboard coupled with buoyancy, and on the other hand, the forces of gravity and fluid drag. Cutting/trimming across the wave front (at an angle to the wave front) requires the same balancing act. If one attempts to reproduce the above described scenario in natural flow conditions, a large water depth is required. Likewise, in the laboratory setting this can be accomplished by deep water flows (reference the Killen papers, *infra*).

Conversely, in a shallow water flow environment, the forward force component of the "skimmer" and skimming device required to maintain a riding position and overcome fluid drag is due to the downslope component of the gravity force created by the constraint of the solid flow forming surface, balanced primarily by momentum transfer from the high velocity upward shooting flow. The "skimmer's" motion upslope (in excess of the kinetic energy of the "skimmer") consists of the force of the upward shooting flow exceeding the downslope component of gravity. In both deep water and shallow water flow environments, non-equilibrium riding maneuvers such as cross-slope motion and oscillating between different elevations are made possible by the interaction between the respective forces as described above and the use of the rider's kinetic energy.

The parent inventions to the subject applications have focused upon deepwater flow shapes specific to the performance of "surfing maneuvers". Surfing maneuvers, is defined by those skilled in the art, as those which occur under ocean like hydrodynamic conditions. Consequently, surfing maneuvers can be performed in an artificial environment, e.g., a wavepool, assuming that the wave which is produced duplicates the ocean wave riding experience (deep water flow) as described above. By corollary, true surfing maneuvers cannot be performed in shallow flow environments since the hydrodynamic conditions are distinct. How-

4

ever, full scale tests have demonstrated that the physical look and feel of "surfing like maneuvers" performed in a shallow flow are surprisingly similar to "real" surfing maneuvers performed in a deep flow. For purposes of technical clarity, shallow flow "surfing type maneuvers" shall be termed as a subset of what hereafter can be described as "water skimming maneuvers". Water skimming maneuvers are defined as those activities which can be performed on shallow water flows including "surfing like maneuvers" as well as other activities or other types of maneuvers with differing types of vehicles e.g. inner-tubes, bodyboards, etc.

The subject invention discloses improvements to the prior art of shallow water flows, as well as similar improvements to the deep water flow shapes of the parent invention. The parent invention generated two types of stationary flow shapes, i.e., a stationary peeling tunnel flow shape for advanced waveriders, and a stationary non-breaking upwardly inclined flow shape for beginners.

#### DISCUSSION OF PRIOR ART

The water recreation field is replete with inventions that generate waves yet lacking as to inventions that create flow formed wave-like shapes. In all cases, none to date describe the improvements contemplated by the subject invention, as an examination of some representative references will reveal.

To facilitate distinction, the prior art can be divided into seven broad wave or wave shape forming categories:

Category 1—an oscillating back-and-forth or periodic up-and-down movement by an object or pressure source that results in disturbance propagation from point to point over a free water surface. Representative prior art: Fisch U.S. Pat. No. 1,655,498; Fisch U.S. Pat. No. 1,701,842; Keller U.S. Pat. No. 1,871,215; Matrai U.S. Pat. 3,005,207; Anderson U.S. Pat. No. 3,477,233; Presnell et al U.S. Pat No. 3,478,444; Koster U.S. Pat. No. 3,562,823; Anderson U.S. Pat. No. 4,201,496; and Baker U.S. Pat. No. 4,276,664. The structure and operation of Category 1 prior art illustrate those types of devices which generate waves in an unsteady flow, i.e., a wave profile which will vary over distance and time.

Category 2—a moving hydraulic jump caused by the release of a quantity of water. Representative prior art: Dexter U.S. Pat. No. 3,473,334; Bastenhof U.S. Pat. No. 4,522,535; and Schuster, et al U.S. Pat. No. 4,538,719. Although differing in method, the structure and operation of Category 2 prior art is similar to Category 1 in that they generate waves in an unsteady flow, i.e., a wave profile which will vary over distance and time. As to the issues of water depth, direction of flow and direction of wave spill, the channel or pool bottoms of Category 2 devices constantly change in depth and become more shallow as one moves in the direction of the traveling wave and released water.

Category 3—a stationary hydraulic jump resulting in a spilling wave. Representative prior art: Le Mehaute U.S. Pat. No. 3,802,697.

Category 4—a moving hydraulic jump caused by a moving hull. Representative prior art: Le Mehaute '697 (*supra*) also disclosed movement by a wedge shaped body through a non-moving or counter-moving body of water, with such movement causing a hydraulic jump and resultant spilling wave suitable for surf-riding.

Category 5—a wave shape that simulates a stationary unbroken wave. Representative prior art: Frenzl U.S.

5,393,170

5

Pat. No. 3,598,402 issued Aug. 10, 1971 is perhaps more closely related in structure to the shallow water flow embodiments of the present invention than any of the previously discussed references. Frenzl disclosed an appliance for practicing aquatic sports such as surf-riding, water-skiing and swimming comprised of a vat, the bottom of which is upwardly sloping and has a longitudinal section which shows a concavity facing upwards while a stream of water is caused to flow upslope over said bottom as produced by a nozzle discharging water into the surface of the lower end of said bottom. Provision is made for adjustment of the slope of the vat bottom around a pivotal horizontal axis to permit the appliance to be adjusted for that sport which has been selected for practice, e.g., water skiing reduced slope or surf-riding increased slope. Provision is also made for varying the speed of the water from a "torrential flow" for water skimming activities, e.g., surfboard riding, to a "river type flow" wherein the speed of the water is matched to the speed of an exercising swimmer. However, Frenzl '402 does not recognize, either explicitly or implicitly some of the problems solved and advantages proffered by the present invention.

Frenzl U.S. Pat. No. 4,564,190 issued Jan. 14, 1986 shows improvements to the appliance for practicing aquatic sports using gliding devices (as disclosed in the Frenzl '402 patent) by introduction of a device that removes water from an upwardly sloping bottom surface which has been slowed down by friction at the boundary faces and returns the water to a pumping system to thereby increase the flow rate and thus eliminate the delirious effects of slowed down water. Frenzl U.S. Pat. No. 4,905,987 issued Mar. 6, 1990 shows improvements to the appliance disclosed in the Frenzl '402 patent (described above) by showing connected areas for swimming, non-swimming and a whirlpool so that water from the Frenzl '402 appliance is further utilized after outflow thereof. The primary objective of the Frenzl '987 patent is to improve the start and exit characteristics of the Frenzl '402 appliance by providing a means whereby a user can enter, ride, and exit the appliance to avoid breakdown of the torrential flow.

Category 6 — a deflective wave shape that simulates a stationary tunnel wave. Representative prior art: Hornung, H. G. and Killen, P., "A Stationary Oblique Breaking wave for Laboratory Testing of Surfboards", *Journal of Fluid Mechanics* (1976), Vol. 78, Part 3, pages 459-484. P. D. Killen, "Model Studies of a Wave Riding Facility", 7th Australasian Hydraulics and Fluid Mechanics Conference, Brisbane, (1980). P. D. Killen and R. J. Stalker, "A facility for Wave Riding Research", Eighth Australasian Fluid Mechanics Conference University of Newcastle, N.S.W. (1983). The apparatus taught by Killen (all three articles will be collectively referred to as Killen, and each article is specifically referenced by chronological date of publication) forms a wave shape of the type favored by surfboard riders, by placing a suitably shaped fixed position obstacle in a channel of specified width and in the path of a flow of water with specified depth and velocity such that deflection of the water off the obstacle duplicates the geometric and hydrodynamic aspects of a surface gravity wave that is obliquely incident to a sloping beach. At first glance, it may appear that structure as taught by Killen and that as disclosed by the subject invention are substantially similar. However, close examination will reveal significant differences.

6

In summary, Killen was attempting to create a wave shape that was geometrically and hydrodynamically similar to the ideal wave in the real surfing situation. The "conforming wave shape" as formed by the shallow water flows of the subject invention does not attempt to geometrically and hydrodynamically simulate the ideal wave in the real surfing situation. The "conforming" deep water flows of the subject invention do not require such simulation, even though they can so simulate.

#### SUMMARY OF INVENTION

To better understand the objects and advantages of the invention as described herein, a list of special terms as used herein are defined:

- (1) "deep water flow": that flow whereby the water depth is sufficient such that boundary layer effects of the sheet flow over the forming surface does not significantly influence the operation of rider or riding vehicle, e.g., surfboard. Deep water flow shapes can, assuming certain flow forming and flow characteristics (e.g., velocity) are met, duplicate naturally occurring waves.
- (2) "shallow water flow": that flow whereby the water is of such depth that the surface boundary layer effects of the sheet flow over the forming surface significantly influences the operation of rider or riding vehicle, e.g., surfboard. Shallow water flow shapes will never duplicate naturally occurring waves.
- (3) "surfing maneuvers": those maneuvers capable of performance on a surfboard which occur under ocean like hydrodynamic conditions, including deep water flows with the appropriate ocean approximating flow characteristics. Surfing maneuvers include riding across the face of the surface of water on a surfboard, moving down the surface toward the lower end thereof, manipulating the surfboard to cut into the surface of water so as to carve an upwardly arcing turn, riding back up along the face of the inclined surface of the body of water and cutting-back so as to return down and across the face of the body of water and the like, e.g., lip bashing, floaters, inverts, aerials, 360's, etc.
- (4) "water skimming maneuvers": those maneuvers which can be performed on shallow water flows including "surfing like maneuvers" (i.e., similar to those described in "surfing maneuvers above) as well as, other activities or other types of maneuvers with differing types of vehicles e.g., inner-tubes, bodyboards, etc.
- (5) "body of water": a volume of water wherein the flow of water comprising that body is constantly changing, and with a shape thereof at least of a length, breadth and depth sufficient to permit surfing or water skimming maneuvers thereon as limited or expanded by the respective type of flow, i.e., deep water or shallow water.
- (6) "conform (conformed, conforming)", where the angle of incidence of the entire depth range of a body of water is (at a particular point relative to the inclined flow forming surface over which it flows) predominantly tangential to said surface. Consequently, water which flows upon an inclined surface can conform to gradual changes in inclination, e.g., curves, without causing the flow to deflect. As a consequence of flow conformity, the downstream termination of an inclined surface will always phys-

5,393,170

7

ically direct and point the flow in a direction aligned with the downstream termination surface. A conformed water flow is a non-separated water flow and a deflected water flow is a separated water flow, as the terms separated and non-separated are known by those skilled in the art.

(7) "equilibrium zone": that portion of an upwardly inclined body of water wherein a rider is in equilibrium depending on the one hand, on an upwardly directed force ascribable to the drag or resistance of the riders vehicle or body dipped into the stream of water and, on the other hand, on a downwardly directed force produced by the component of the weight of the rider in a direction parallel with the inclined water forming means.

(8) "supra-equidyne area": that portion of a body of water above the equilibrium zone wherein the slope of the incline is sufficiently steep to enable a rider to overcome the upwardly sheeting water flow and slide downwardly thereupon.

(9) "sub-equidyne area": that portion of a body of water below the equilibrium zone that is predominantly horizontal. In the sub-equidyne area a rider cannot achieve equilibrium and will eventually (due to the forces of fluid drag) be moved back up the incline.

One object of the present invention is to improve upon the parent invention by providing a flow forming surface upon which a shallow water flow can produce a body of water that is similar to the kind prized by surfers, i.e., a tunnel wave, which has a mouth and an enclosed tunnel extending for some distance into the interior of the forward face of the wave-shape. Such improvement is hereinafter referred to as the "Shallow Flow Tunnel Wave Generator." Heretofore, tunnel waves have only been available to surfers in a natural or deep water flow environment. The subject invention, through proper configuration of a flow forming surface and adequate shallow water flow characteristics (e.g., velocity, turbidity, depth, direction, etc.), can produce wave forms that have similar appearance and ride characteristics as "real" tunnel waves subject to certain ride conditions, e.g., limitation on surfboard fin size. However, the significant cost savings attributable to shallow flow construction and reduced energy consumption outweigh any limitations that may be imposed.

The parent invention also provided for a stationary non-breaking upwardly inclined deep water flow shape for beginners. The subject invention will also improve upon this embodiment of the parent invention through the use of shallow water flow technology. Such improvement is hereinafter referred to as the "Shallow Flow Inclined Surface." In addition to the significant advantage or reduced cost, additional advantages to the shallow water improvements described above include, increased safety due to reduced deep water pool depth, reductions in water maintenance due to decrease in volume of water treated, and the opportunities to create novel water sports, e.g., flowboarding or inner-tube "bumper cars".

A second object of the subject invention is to provide a flow forming means (hereinafter referred to as the "Connected Structure") comprised of a substantially horizontal flat surface (the sub-equidyne area) that transitions by way of a radial concave arc (the equilibrium zone) connected to the supra-equidyne area (e.g., the inclined plane or tunnel wave generator). The Connected Structure facilitates a riders ability to maximize

8

his forward speed by the riders own efforts of "pump-turning", hereinafter more fully described as the "Acceleration Process". Without benefit of said Connected Structure such increased speed would not be available. The Connected Structure encompasses the complete spectrum of surface flows and wave shapes desired by wave-riding and water skimming enthusiasts. Beginning at one extreme with a flat incline, and progressing by introduction of an increasing array of surface curvatures from the horizontal to the vertical combined with varying attitude and inclination of said surface relative to an upward (or downward, as the case may be) flow of water that culminates at the other extreme in a tunnel wave shape. A significant feature of the Connected Structure is how its unique configuration can dramatically improve the performance parameters of the parent invention's inclined Surface embodiment. The parent invention hereto permitted conventional surfing maneuvers; however, its structure did not optimally facilitate the generation of forward speed with which to perform such maneuvers. The "Acceleration Process" as now enabled by the Connected Structure improvement allows such forward speed to be attained.

A third object of the subject invention is to solve the transient surge problems associated with the ride start-up and rider induced flow decay upon upwardly inclined flow surfaces. This solution results by lowering the downstream boundary area of the inclined flow forming surface at an angle so as to create a maximum height ridge line of decreasing elevation to facilitate self-clearing of undesirable transitory surges. This improvement is hereinafter referred to as the "Self-Clearing Incline."

A fourth object of the subject invention and a novel ramification to the "Self-Clearing Incline" occurs by extending the inclined flow forming surface and associated ridge line of the downstream boundary area to an increased elevation. If such increase in elevation is in excess of the net total head flow necessary to scale this new increase in elevation, then the flow will form a hydraulic jump and the sub-critical water thereof will spill down the upwardly sheeting flow in the manner of a spilling wave. This improvement is hereinafter called the "Inclined Riding Surface with Spilling Wave". The spilling wave phenomena can also be incorporated into the other embodiments as described herein. A corollary improvement to any spilling wave application is a properly configured vent system to handle the water which spills back down the flow forming surface. If such water remained unvented, it would eventually choke the entire flow. Consequently, to maintain a steady state condition, to the extent that new water flows into the system, then, an equal amount of old water must vent out.

A fifth object of the subject invention is to improve by way of combination the tunnel and inclined flow forming surfaces, as well as, creation of an intermediate "spilling wave" that works in combination with the inclined flow surface. This embodiment is hereinafter referred to as the "Omni-Wave". A feature of the Omni-Wave embodiment is its unique flow forming shape can permit (by way of a progressive increase of the net head of the sheet flow) the transformation of a sheet of water flow from a stationary "spilling wave" along the entire forming means, to a transitional "spilling wave" with inclined surface flow, to the final inclined surface flow and tunnel wave shape. This method is hereinafter referred to as the "Wave Transformation Process". The Omni-Wave and the Wave Transformation Process will

5,393,170

9

offer an improved environment for the performance of surfing and water skimming maneuvers.

A sixth object of the present invention is to provide an apparatus that will enable riders to perform surfing and water skimming maneuvers in a format heretofore unavailable except by analogy to participants in the separate and distinct sports of skateboarding and snowboarding, to wit, half-pipe riding. In this regard, the present invention comprises a method and apparatus for forming a body of water with a stable shape and an inclined surface thereon substantially in the configuration of a longitudinally oriented half-pipe. Such improvement is hereinafter referred to as the "Fluid Half-Pipe." A corollary improvement to the Fluid Half-Pipe is to provide an apparatus that permits an increased throughput capacity by increasing the depth of the Fluid Half-Pipe in the direction of its length. This increase in depth will have the added benefit of causing a rider to move in the direction of fall and facilitate his course through the ride.

The final object of the present invention is the positioning of dividers within a Fluid Half-Pipe or Inclined Surface as described above and to prevent a "jet wash" phenomenon that can result in loss of a rider's flow. This "jet wash" phenomenon occurs when a rider who is positioned in the equilibrium or supra-equidyne area of a thin sheet flow gets his flow of water cut off by a second rider positioned with priority to the line of flow. The cutting off of water occurs in thin sheet flow situations due to the squeegee effect caused by the second rider's skimming vehicle. The improvement aids in preventing adjacent riders from cutting off their respective flows of water. Such improvement is hereinafter referred to as "Sheet Flow Dividers."

Other objectives and goals will be apparent from the following description taken in conjunction with the drawings included herewith.

#### BRIEF DESCRIPTION OF THE DRAWINGS

FIG. 1 is a profile view of a Tunnel "Wave" Generator configured for shallow waterflows.

FIG. 2 is a contour map of Tunnel "Wave" Generator as set forth in FIG. 1.

FIG. 3 is a plan view of the range of horizontal attitude with respect to the direction of water flow that the wave generator (as set forth in FIG. 1) can take and still form a tunnel wave.

FIG. 4 is a view in profile of a typical cross-section disclosing the range of inclination of the forward face of the wave generator (as set forth in FIG. 1) with respect to the direction of water and orientation to the vertical.

FIG. 5 depicts a rider on the Tunnel Wave Generator.

FIG. 6 is a profile view of the inclined surface.

FIG. 7 is a cross-sectional view of the inclined surface as shown in FIG. 6.

FIG. 8 depicts a rider on the Inclined Surface.

FIG. 9a is a profile view of the Connected Structure.

FIG. 9b is a cross-section of FIG. 9a.

FIG. 10 depicts a surfer riding an Inclined Surface as improved by the Connected Structure and who is taking advantage of the acceleration process.

FIG. 11a is a profile view of the Self Clearing Incline.

FIG. 11b is a cross-section of FIG. 11a.

FIG. 12 is a contour map of the Self-Clearing Tunnel Wave.

10

FIG. 13a, FIG. 13b, and FIG. 13c are three views in profile that illustrate in time lapse sequence a self-clearing Inclined Surface.

FIG. 14a and FIG. 14b, illustrate in time lapse sequence the self-clearing Tunnel Wave.

FIG. 15 is a profile view of the Omni-Wave.

FIG. 16a depicts the Omni-Wave with a spilling wave formed along its entire front face.

FIG. 16b depicts the Omni-Wave with a clear inclined surface a spilling wave.

FIG. 16c depicts the Omni-Wave with a clear inclined surface and a Tunnel Wave.

FIG. 16d depicts a Body Boarder performing water skimming maneuvers and a surfer performing surfing maneuvers on the Omni-Wave.

FIG. 16e depicts a knee boarder riding the spilling wave.

FIG. 16f depicts a water skier on the inclined surface and an inner-tube rider on the spilling wave.

FIG. 17 shows in profile view of a novel embodiment for water sports—the Fluid Half-Pipe.

FIG. 18a shows an elevation of a typical Fluid Half-Pipe.

FIG. 18b shows an elevation of a Fluid Half-Pipe with modified flow forming bottom to assist in capacity and rider throughput.

FIG. 19 illustrates in profile view an improvement to the Fluid Half-Pipe to assist in increased throughput capacity.

FIG. 20 shows dividers in a shallow flow to avoid flow "jet wash."

#### DETAILED DESCRIPTION OF THE SUBJECT INVENTION

Because the original application, the continuation of the original application and the subject invention are operated in water, and many of the results of its passage there-through, or the propelling of water against the wave or flow forming means thereof, are similar to those caused by a boat hull, some of the terms used in the descriptions hereto will be nautical or marine terms; likewise, from the perspective of physical water dynamics, some of the terms used herein will be hydraulic engineering terms; and finally, from the perspective of ride operation and function, some of the terms used herein will be terms as used in the sport of surfing; all such terms constitute a ready-made and appropriate vocabulary which is generally understood by those skilled in the art. To the extent that there are special terms, then, those terms are further defined herein.

Further, it will be understood by those skilled in the art that much of the description of structure and function of the wave generator and inclined surface of the original application and its continuation application may apply to the embodiments of the subject invention, to the extent used by this application. Therefore, the descriptions of the flow forming means/wave generator hull and inclined surface of the prior applications should also be read in conjunction with FIGS. 1-20. However, to the extent there are any differences or discrepancies between the description and teaching of the prior applications and the subject invention, the description and teaching of the subject invention shall prevail.

Except where specifically limited, it is to be understood that the embodiments as described herein are to function in both deep and shallow flow environments. Furthermore, that the flow (except where noted) is to be super-critical (i.e., according to the formula  $v > \sqrt{gd}$

5,393,170

11

where  $v$  = velocity,  $g$  = acceleration due to gravity ft/sec<sup>2</sup>,  $d$  = depth of the sheeting body of water).

Description of Shallow Flow Tunnel "Wave" Generator

Turning now to FIG. 1 (isometric view) and FIG. 2 (contour map) there is illustrated a Tunnel "Wave" Generator 30 similar to the generator of prior application, however, improved to serve in a shallow water flow. Plan-sectional lines as revealed in FIG. 1 and contour lines as revealed in FIG. 2 are solely for the purpose of indicating the three-dimensional shape in general, rather than being illustrative of specific frame, plan, and profile sections. Tunnel Generator 30 is comprised of a stem 31, a front face 32, a stern arch 33, an upstream edge 34 running from stem 31 to stern arch 33 and acting as the upstream perimeter of front surface 32, a downstream edge 35 running from stem 31 to stern arch 33 and acting as the downstream perimeter of front face 32, back surface 36, and sub-surface structural support 37. Front surface 32, bounded by upstream edge 34, downstream edge 35 and stern arch 33 is that feature of Tunnel Generator 30 which effectively shapes its tunnel "wave." Moving in a direction as indicated by arrow 38, super-critical shallow water flow 39 originating from a water source (not shown) moves in a conforming flow upward over the front face 32 to form an inclined body of water in the shape of a tunnel "wave" (not shown) upon which a rider (not shown) can ride. Back surface 36 is sufficiently smooth and with transitions analogous to a conventional waterslide such that a rider (not shown) could safely be swept over or around Tunnel Generator 30 to a termination pool or area (not shown) to properly exit. The outside dimensions of the flow forming front face 32 of Tunnel Generator 30 are capable of a broad range of values which depend more upon external constraints, e.g., financial resource, availability of water flow, etc., rather than specific restrictions on the structure itself. However, for purposes of scale and not limitation, in order to form a tunnel "wave" of adequate size to fully accommodate an adult user, the outside dimensions of Tunnel Generator 30 should be approximately 1 to 3 meters in height and 3 to 12 meters in length.

At least three characteristics of front face 32 of Tunnel Generator 30 influence the size, shape and angle of the tunnel "wave," and each of them interacts with the others:

- A. its shape (FIG. 1 and 2);
  - B. its attitude —its horizontal position or angle with respect to the direction of water flow (FIG. 3); and
  - C. its inclination—its vertical position or angle with respect to the direction of water flow (FIG. 4).
- Each characteristic of front face 32 is now discussed in detail.

A. Shape

Front face 32 of Tunnel Generator 30 has a complex shape comprised of concave curvature, both vertically and horizontally, as indicated generally by the FIG. 1 plan sections lines and FIG. 2 contour lines. Such lines are substantially but not specifically illustrative of the range of possible shapes, as will now be explained more fully:

1. Vertically:

- a. the shape of the vertical curvature can be:
  - (1) substantially a simple arc of a circle; or
  - (2) preferably an arc of a more complex changing curve, e.g.:

12

- (a) ellipse;
- (b) parabola;
- (c) hyperbola; or
- (d) spiral.

- 5 If a changing curve, it preferably changes from an opening curve (i.e., the ascending water encounters an increasing radius as it ascends front face 32) at stem 31 through a transition point 40; to a closing curve (i.e., the ascending water encounters a decreasing radius as it ascends front face 32) from transition point 40 to stern arch 33. A critical feature of Tunnel Generator 30 is that commencing at transition point 40, front face 32 begins to curve past the vertical. Curvature past the vertical from transition point towards the stern arch 33 gradually increases from 0 to a maximum of 30 degrees. 10 degrees if preferred.

2. Horizontally

a. The shape of the horizontal curvature can be:

- (1) substantially an arc of a circle; or
- (2) preferably, a portion of a more complex, changing curve, e.g.:
  - (a) ellipse;
  - (b) parabola;
  - (c) hyperbola; or
  - (d) spiral.

B. Attitude

As disclosed in FIG. 3, the horizontal attitude of front face 32 with respect to direction 38 of water flow can vary only within certain limits otherwise the "tunnel" will not develop. Since front face 32 has concave curvature of varying degrees along its horizontal axis, for purposes of orientation an extension of upstream edge 34 is used to indicate varying horizontal attitudes of front face 32 therefrom. Accordingly, upstream edge 34 can vary from substantially perpendicular to the direction 38 of water flow to an angle of approximately 35 degrees, as shown.

C. Inclination

As disclosed in FIG. 4, the inclination of the front face 32 with respect to the direction 38 of water flow is also limited, otherwise the tunnel will not be developed. Two factors are important with respect to inclination, first, the change in angle of incline relative to the depth of the water must be sufficiently gradual to avoid separation of flow lines/deflection. Second, the angle of release (as defined by a line tangent to front face 32 at downstream edge 35 when compared to the vertical) must be past the vertical as shown. Amounts past vertical may vary, however, a preferred amount is 10 degrees.

- 55 At least two other factors effect the size and shape of tunnel wave formation, i.e., flow velocity and water flow depth. The velocity of the water over Tunnel Generator 30 has a wide range, dependent upon the overall size of the Tunnel Wave Surface and the depth of water. In general, the flow is to be super-critical (i.e., according to the formula  $v > \sqrt{gd}$  where  $v$  = velocity,  $g$  = acceleration due to gravity ft/sec<sup>2</sup>,  $d$  = depth of the sheeting body of water). However, velocities in excess of that which is at a minimum necessary to achieve supercritical velocity are sometimes desired, e.g., to provide sufficient momentum transfer to support the weight component of a given rider, and to achieve the vertical heights required to form a tunnel "wave."

- 65 The depth of the water is primarily a function of the minimum necessary to permit a tunnel "wave" to form at a given height, and simultaneously enable the flow of water to support (via momentum transfer) the weight

5,393,170

13

component of a contemplated range of users. Because of the operational requirements of momentum transfer, the depth of the water has direct relationship to the velocity of the water, i.e., the higher the velocity of flow, the lower the requisite depth. Since this embodiment is limited to shallow flows, the depth of water will range from approximately 2 to 40 centimeters.

Tunnel Generator 30 can be fabricated of any of several of well known materials which are appropriate for the use intended. Concrete; formed metal, wood, or fiberglass; reinforced tension fabric; air, foam or water filled plastic or fabric bladders; or any such materials which will stand the structural loads involved. A preferred embodiment includes a thick foamed plastic covering to provide additional protection for the riders using the facility.

Theoretically, no pool or water containment means is required for Tunnel Generator 30, in that the flow from a suitable flow source (e.g., pump and nozzle, fast moving stream or elevated reservoir/lake) is all that is required. However, where water recycling is preferred, then, low channel walls can be constructed to retain the flowing water with a lower collection pool, recycling pump and appropriate conduit connected back to the upstream flow source. The area of channel containment need be only large enough to allow the performance of appropriate water skimming maneuvers, since the curling water of the tunnel wave would remain more or less stationary with respect to the containment structure. Thus, such a structure could be constructed even in a backyard.

From the description above, a number of advantages of Tunnel "Wave" Generator 30 becomes evident:

- (a) The energy required to produce a tunnel "wave" shape under shallow flow conditions is dramatically less than that required under "natural" conditions, e.g., as indicated in Killen's 1980 article, the power required to produce operational natural waves is proportional to the height of the wave raised to the 3.5 power ( $hw^{3.5}$ ). Consequently, a 2 meter wave would require 11.3 times the power of a 1 meter wave or approximately 3.7 mega watts or 4800 horsepower. An 8 cm in depth shallow flow wave as contemplated by the subject invention with similar width to Killen's structure would be able to produce a 2 meter high tunnel "wave" for under 400 horsepower.
- (b) The capital costs and operating costs for shallow water tunnel "wave" generation is substantially less than deep water installations.
- (c) The sight, sound, and sensation of tunnel "wave" riding is a thrilling participant and observer experience, that has heretofore only been available to relatively few people in the world. The subject invention will enable this experience to become more readily available.
- (d) From a safety perspective, shallow water is generally perceived as safer in view of drowning.

#### Operation of the Tunnel "Wave" Generator

FIG. 5 illustrates Tunnel Generator 30 in operation with the concavity of front face 32 acting to shape a water walled tunnel from super-critical shallow water flow 39 within and upon which rider 41 can ride. Water flow 39 originating from a water source (not shown) moves in a direction 38 as indicated. At stem 31 water flow 39 moves over front face 32 and onto back surface (not shown). Back surface (not shown) is sufficiently

14

smooth and with transitions analogous to a conventional waterslide such that rider 41 could safely be swept over or around Tunnel Generator 30 to a termination pool or area (not shown) to properly exit. Progressing from transition point 40 to stern arch 33 the horizontal and vertical concavity of front face 32 acts as a scoop to channel and lift water into the central portion of front face 32 towards stern arch 33. Combined with the attitude of Tunnel Generator 30 relative to the direction 38 of water flow 39, the resultant forces thereto propel water flow 39 along the path of least resistance which is upward and outward creating the desired tunnel 42. Tunnel 42 size is adjustable depending upon the velocity of water flow 39, i.e., the higher the flow velocity the larger the tunnel effect. The forward force component required to maintain rider 41 (including any skimming device that he may be riding) in a stable riding position and overcome fluid drag is due to the downslope component of the gravity force created by the constraint of the solid flow forming surface balanced primarily by momentum transfer from the high velocity upward shooting water flow 39. Rider's 41 motion upslope (in excess of the kinetic energy of rider 41) consists of the force of the upward shooting water flow 39 exceeding the downslope component of gravity. Nonequilibrium riding maneuvers such as cross-slope motion and oscillating between different elevations on the "wave" surface are made possible, by the interaction between the respective forces as described above and the use of the rider's kinetic energy.

Accordingly, it should now be apparent that Tunnel "Wave" Generator 30 embodiment of this invention can use shallow water flow in a water ride attraction to simulate ocean tunnel waves. In addition, Tunnel "Wave" Generator 30 has the following advantages:

- it requires a fraction of the energy utilized in generating a "real" wave;
- it costs substantially less to build and maintain;
- it allows a rider to experience the sight, sound, and sensation of tunnel wave riding, an experience that heretofore has not been available in commercial settings;
- it uses shallow water which is inherently safer than deep water in the prevention of drowning.

#### Description of Shallow Flow Inclined Surface

Turning now to FIG. 6, there is illustrated shallow flow inclined surface 44. Plan-sectional lines as revealed in FIG. 6 are solely for the purpose of indicating the three-dimensional shape in general, rather than being illustrative of specific frame, plan, and profile sections. Shallow flow inclined surface 44 is comprised of sub-surface structural support 45; back surface 46; and front face 47 which is bounded by an imaginary downstream ridge line 48, an upstream edge 49, and side edge 50a and 50b. Side edge 50 can have walls (not shown) or be connected with conventional broad surfaced downhill sliding transitions (not shown) to either contain or allow a rider to move out and off of the flow. Front face 47 can either be a gradual sloping inclined plane, a continuous concave planar surface, a concave planar surface joined to a convex planar surface, or preferably a combination of planar curved surfaces and planar inclined surfaces. FIG. 7 shows in cross-section a preferred profile of front face 47 with upstream edge 49 (indicated as a point in this cross-sectional view) as the upstream boundary and with a combination of curves and straight inclines as follows: concave curvature 51 as one moves

15

upwards towards the downstream ridge 48 (indicated as a point in this cross-sectional view); concave curvature 51 transitioning to a straight incline 52 at a concave/straight transition point 53; straight incline 52 continuing to straight/convex transition point 55; and convex curvature 56 from straight/convex transition point 55 to downstream ridge 48. Back surface 46 joins front face 47 at the downstream ridge line 48. Back surface 46 is sufficiently smooth and with transitions analogous to a conventional waterslide such that a rider (not shown) could safely be swept over downstream ridge line 48 to a termination pool or area (not shown) to properly exit. Turning back to FIG. 6, super critical water flow 39 originating from a water source (not shown) moves in direction 38 to produce a conforming upward flow over front face 47, the downstream ridge line 48 and onto the back surface 46 to form an inclined body of water upon which a rider (not shown) can ride. The outside dimensions of the flow forming front face 47 of shallow flow inclined surface 44 are capable of a broad range of values which depend more upon external constraints, e.g., financial resource, availability of water flow, etc., rather than specific restrictions on the structure itself.

The velocity of the water over shallow flow inclined surface 44 has a wide range, dependent upon the overall size of the inclined surface and the depth of water. In general, the flow is to be super-critical (i.e., according to the formula  $v > \sqrt{gd}$  where  $v$ =velocity,  $g$ =acceleration due to gravity ft/sec<sup>2</sup>,  $d$ =depth of the sheeting body of water). However, velocities in excess of that which is at a minimum necessary to achieve super-critical velocity are sometimes desired, e.g., to provide sufficient momentum transfer to support the weight component of a given rider, and to achieve the vertical heights required to form an unbroken "wave."

The depth of the water is primarily a function of that which is necessary to successfully operate for the purposes intended. Because of the operational requirements of momentum transfer, the depth of the water has direct relationship to the velocity of the water, i.e., the higher the velocity of flow, the lower the requisite depth. Since this embodiment is limited to shallow flows, the depth of water will range from approximately 2 to 40 centimeters.

Shallow flow inclined surface 44 can be fabricated of any of several of well known materials which are appropriate for the use intended. Concrete; formed metal, wood or fiberglass; reinforced tension fabric; air, foam or water filled plastic or fabric bladders; or any such materials which will stand the structural loads involved. A preferred embodiment includes a thick foamed plastic covering to provide additional protection for the riders using the facility.

Theoretically, no pool or water containment means is required for shallow flow inclined surface 44, in that the flow from a suitable flow source (e.g., pump and nozzle, fast moving stream or elevated reservoir/lake) is all that is required. However, where water recycling is preferred, then, low channel walls can be constructed to retain the flowing water with a lower collection pool, recycling pump and appropriate conduit connected back to the upstream flow source. The area of channel containment need be only large enough to allow the performance of appropriate water skimming maneuvers. Thus, such a structure could be constructed even in a back yard.

From the description above, a number of advantages of Shallow Flow Inclined Surface 44 becomes evident:

5,393,170

16

- (a) The energy required to produce an unbroken "wave" shape similar to that simulated by Shallow Flow Inclined Surface 44 is dramatically less than that required under "natural" conditions, e.g., as indicated in Killen's 1980 article, the power required to produce operational natural waves is proportional to the height of the wave raised to the 3.5 power ( $hw^{3.5}$ ). Consequently, a 2 meter wave would require 11.3 times the power of a 1 meter wave or approximately 3.7 mega watts or 4800 horsepower. An 8 cm in depth shallow flow wave as contemplated by the subject invention with similar width to Killen's structure would be able to produce a 2 meter high inclined surface "wave" for under 400 horsepower.
- (b) The capital costs and operating costs for shallow water inclined surface "wave" generation is substantially less than deep water installations.
- (c) The sight, sound, and sensation of inclined surface "wave" riding is a thrilling participant and observer experience, that has heretofore only been available to relatively few people in the world. The subject invention will enable this experience to be become more readily available.
- (d) From a safety perspective, shallow water is generally perceived as safer in view of drowning.

#### Operation of Shallow Flow Inclined Surface

FIG. 8 illustrates Shallow Flow Inclined Surface 44 in operation. Super-critical water flow 39 originating from a water source (not shown) moves in direction 38 to produce a conforming upward flow over front face 47, the downstream ridge line 48 and onto the back surface 46 to form an inclined body of water upon which rider 41 can ride. Front face 47 serves as the primary riding area for rider 41. On this area rider 41 will be able to perform skimming maneuvers as follows: The forward force component required to maintain rider 41 (including any skimming device that he may be riding) in a stable riding position and overcome fluid drag is due to the downslope component of the gravity force (created by the constraint of sub-surface structural support 45) balanced primarily by momentum transfer from the high velocity upward shooting water flow 39. The motion of rider 41 in an upslope direction (in excess of the kinetic energy of rider 41) consists of the force of the upward shooting water flow 39 exceeding the down slope component of gravity. Non-equilibrium riding maneuvers such as cross-slope motion and oscillating between different elevations on the "wave" surface are made possible by the interaction between the respective forces as described above and the use of rider's 41 kinetic energy. Back surface 46 is sufficiently smooth and with transitions analogous to a conventional waterslide such that rider 41 could safely be swept over downstream ridge line 48 to a termination pool or area (not shown) to properly exit.

Accordingly, it should now be apparent that Shallow Flow Inclined Surface 44 embodiment of this invention can use shallow water flow in a water ride attraction to simulate unbroken ocean waves. In addition, Shallow Flow Inclined Surface 44 has the following advantages: it requires a fraction of the energy utilized in generating a "real" wave; it costs substantially less to build and maintain; it allows a rider to experience the sight, sound, and sensation of continuous unbroken wave riding, an experience that hereto for has not been available in

17

commercial settings. Such capability will greatly expand the training of beginning "surf-riders" and provide a venue for surf-camps, etc. it uses shallow water which is inherently safer than deep water in the prevention of drownings.

#### Description of Connected Structure

The Connected Structure creates additional surface area beyond the areas defined by Tunnel Wave Generator 30 and Shallow Flow Inclined Surface 44. In general terms, this expanded area can be described as a horizontal area upstream of the upstream edge of each respective embodiment. Furthermore, the Connected Structure describes specific ratios between three distinct regions that can be defined to exist on Tunnel Wave Generator 30 and Shallow Flow Inclined Surface 44 as improved by the Connected Structure. Through combination of area expansion and defined region size relationship, a flow forming means can be described with performance characteristics as yet undisclosed by the prior art.

Turning now to FIG. 9a, we see a generalized diagram of an improvement for a flow forming means herein called Connected Structure 57. Plan-sectional lines as revealed in FIG. 9a are solely for the purpose of indicating the three-dimensional shape in general, rather than being illustrative of specific frame, plan, and profile sections. Connected Structure 57 is comprised of a supra-equidyne area 58 which transitions (as represented by a dashed line 59) to an equilibrium zone 60, which in turn transitions (as represented by a dotted line 61) to a sub-equidyne area 62. The dimensions and relationship of Connected Structure's 57 sub-equidyne 62, equilibrium 60, and supra-equidyne 58 areas are described as follows:

FIG. 9b illustrates a cross-section of Connected Structure 57, with sub-equidyne area 62, equilibrium zone 60, and supra-equidyne area 58 with a range of configurations 58a, 58b, and 58c that are capable of producing a flow that ranges from the previously described unbroken "wave" (i.e., inclined flow) and the tunnel "wave" flow.

The preferred embodiment for the breadth of the sub-equidyne area 62 in the direction of flow 38 is, at a minimum, one and one half to four times the vertical height (as measured from sub-equidyne to the top of supra-equidyne) of the total flow forming means. The large breadth would apply to low elevation means (e.g., 1 meter) and smaller breadth to high elevation means (e.g., 6 meters). Sub-equidyne 62 orientation is substantially horizontal and normal to the force of gravity.

The preferred embodiment for the shape of equilibrium zone 60 can be defined by a portion of a changing curve, e.g., an ellipse; parabola; hyperbola; or spiral. If a changing curve, the configuration of equilibrium zone 60 is substantially arcs of a closing curve (i.e., the ascending water encounters a decreasing radius as it ascends the face of the flow forming means). The radius of said closing curve being at its smallest approximating the radius of supra-equidyne 58 leading edge, and at its longest less than horizontal. For purposes of simplicity and scale (but not by way of limitation) the uphill breadth of equilibrium zone 60 can generally be defined by a distance approximately equal to the length of the rider's flow skimming vehicle, i.e., approximately three to ten feet.

The preferred embodiment for the shape of supra-equidyne area 58 can be defined by a portion of chang-

5,393,170

18

ing curve, e.g., an ellipse; parabola; hyperbola; or spiral. If a changing curve, the configuration of supra-equidyne area 58 is initially arcs of a closing curve (i.e., the ascending water encounters a decreasing radius as it ascends the face of the flow forming means). The radius of said closing curve is at its longest always less than the radius of the longest arc of equilibrium zone 60, and, at its smallest of sufficient size that a rider could still fit inside a resulting "tunnel wave". On the opposite end of the spectrum, said arcs of a closing curve can transition, after a distance at least equal to  $\frac{1}{3}$ 's the length of the riders flow skimming vehicle (approximately two to seven feet), to arcs of an opening curve (i.e., the ascending water encounters an increasing radius as it ascends the face of the flow forming means). The only limitation as to the overall breadth of supra-equidyne area 58 in the direction of flow 38 is the practical limitation of available head of an upwardly sheeting flow.

Super-critical water flow 39 originating from a water source (not shown) moves in direction 38 to produce a conforming flow over sub-equidyne area 62, equilibrium zone 60, and supra-equidyne area 58 to form an inclined body of water upon which a rider (not shown) can ride and perform surfing or water skimming maneuvers that would not be available but for such Connected Structure 57.

#### Operation of the Connected Structure

The significance of Connected Structure 57 is a function of how it can be used to enable the performance of surfing and water skimming maneuvers. Essential to the performance of modern surfing and skimming maneuvers are the elements of oscillation, speed, and proper area proportion in the "wave" surface that one rides upon. Each element is elaborated as follows:

**OSCILLATION:** The heart and soul of modern surfing is the opportunity for the rider to enjoy substantial oscillation between the supra-critical and sub-critical areas. As one gains expertise, the area of equilibrium is only perceived as a transition area that one necessarily passes through in route to supra and sub critical areas. Oscillatory motion has the added advantage of allowing a rider to increase his speed.

**SPEED:** Speed is an essential ingredient to accomplish modern surf maneuvers. Without sufficient speed, one cannot "launch" into a maneuver. The method and means for increasing one's speed on a properly shaped wave face can be made clear by analogy to the increase of speed on a playground swing as examined in SCIENTIFIC AMERICAN, March 1989, p. 106-109. On a swing, if one is crouching at the highest point of a swing to the rear, one's energy can be characterized as entirely potential energy. As one descends, the energy is gradually transformed into kinetic energy and one gains speed. When one reaches the lowest point, one's energy is entirely kinetic energy and one is moving at peak speed. As one begins to ascend on the arc, the transformation is reversed: one slows down and then stops momentarily at the top of the arc. Whether one goes higher (and faster) during the course of a swing depends on what one has done during such swing. If one continues to crouch, the upward motion is a mirror image of the downward motion, and one's center of mass ends up just as high as when one began the forward swing. If instead one stands when one is at the lowest point, i.e., "pumping" the swing, then one would swing higher and faster.



5,393,170

19

The importance of sub-equidyne area 62 in the context of the previous discussion of swing dynamics, is that sub-equidyne area 62 is by its nature the lowest point on Connected Structure 57 and on a wave. Standing/extending at this low point results in a larger increase of speed than if one stood at any other point on Connected Surface 57 or on a wave. This increase in speed and total kinetic energy is due to two different mechanistic principals, both of which may be utilized by a rider on Connected Structure 57 or a wave. By standing at the lowest point in the oscillatory path, the center of gravity of the rider is raised allowing a greater vertical excursion up the slope than the original descent. Crouching at the top of the path and alternately standing at the bottom allows an increase in vertical excursion and restoration of energy lost to fluid drag. Additionally, the other mechanism, increasing the kinetic energy, is due to the increase in angular rotation. As the rider in his path rotates around a point located up the wave face, extension/standing at the low point increases his angular velocity much in the same manner as a skater by drawing in his/her arms increases his/her rotational speed due to the conservation of momentum. However, kinetic energy increases due to the work of standing against the centrifugal force and because kinetic energy is proportional to the square of angular velocity, this increase in kinetic energy is equivalent to an increase in speed.

**PROPER AREA PROPORTION:** Connected Structure 57 as a flow forming surface combines in proper proportion the sub-critical 62, equilibrium 60, and supra-critical 58 areas so as to enable a rider to oscillate, attain the requisite speed and have available the requisite transition area for performance of modern day surfing and skimming maneuvers that would not be possible, but for said Connected Structure 57.

Turning to FIG. 10 there is illustrated a surfer 63 on an inclined surface as improved by Connected Structure 57 in various stages of a surfing maneuver. Surfer 63 is in a crouched position on supra-equidyne area 58 and gathering speed as he moves downward over a conformed sheet of super-critical water flow 39 which originates from a water source (not shown) and moves in direction 38. Upon reaching the low point at sub-equidyne area 62, surfer 63 extends his body and simultaneously carves a turn to return to supra-equidyne area 58. As a consequence of such maneuvering, surfer 63 will witness an increase in speed to assist in the performance of additional surfing maneuvers. The process by which a surfing or water skimming rider can actively maneuver to increase his speed is referred to as the Acceleration Process.

#### Description of Self-Clearing Incline and Tunnel Wave

Turning to FIG. 11a (isometric view) and FIG. 11b (cross-sectional view) there is illustrated a top vent self-clearing incline improvement for Shallow Flow Inclined Surface (as improved by Connected Structure) all of which is hereafter referred to as a Self-Clearing Incline 64. Self-Clearing Incline 64 is comprised of Shallow Flow Inclined Surface as modified by lowering the elevation of side edge 50b' and causing downstream ridge line 48 to incline from the horizontal. FIG. 11b superimposes a cross-sectional profile of side edge 50a over the lowered side edge 50b'. To have a noticeable effect, the angle of inclination should be a minimum 5 degrees.

20

Turning to FIG. 12 (contour map) there is illustrated a swale self-clearing incline improvement for Tunnel "Wave" Generator 30 (as improved by Connected Structure 57) all of which is hereafter referred to as Self-Clearing Tunnel Wave 66, comprised of sculpting from front surface 32, sub-equidyne area 62 and structural matrix support 37 (not shown) a shallow venting swale 65. All surfaces of swale 65 are smooth and without edges.

#### Operation of Self-Clearing Incline and Tunnel Wave

Self-Clearing Incline 64 and Self-Clearing Tunnel Wave 66 are designed to prevent unwanted turbulent white water build-up that fails to clear from the riding surface in the usual manner of "washing" over the downstream ridge of these respective embodiments. In practice, this vent problem will only occur if there is a restriction on flow venting to the side of the inclined surface or generator, e.g., a channel wall, or where there is a tremendous amount of activity, e.g., multiple riders on the surface of the water.

This undesirable build-up is particularly acute in an upward directed flow. This build-up will most likely occur during three stages of operation, (1) water flow start-up with no rider present; (2) transferring the kinetic energy of high speed water flow to a maneuvering rider; and (3) cumulative build-up of water due to a spilling wave. In the start-up situation (1), due to the gradual build up of water flow associated with pump-/motor phase in or valve opening, the initial rush is often of less volume, velocity or pressure than that which issues later. Consequently, this initial start water is pushed by the stronger flow, higher pressure, or faster water that issues thereafter. Such pushing results in a build-up of water (a hydraulic jump or transient surge) at the leading edge of the flow. An upward incline of the riding surface serves only to compound the problem, since the greater the transient surge, the greater the energy that is required to continue pushing such surge in an upward fashion. Consequently, the transient surge will continue to build and if unrelieved will result in overall flow velocity decay, i.e., the slowed water causes additional water to pile up and ultimately collapse back onto itself into a turbulent mass of bubbling white water that marks the termination of the predominantly unidirectional super-critical sheet flow. In the situation of kinetic energy transfer (2), when a maneuvering rider encounters faster flowing water or water that is moving in a direction different than the rider, a transient surge builds behind or around the rider. Likewise, if this transient surge grows too large it will choke the flow of higher speed unidirectional super-critical sheet flow, thus, causing flow decay. In the situation of an excessive build up of water over time from a spilling wave (3), the interference of a preceding flow with a subsequent flow can result in an undesired transient surge and flow decay at a point near where the two flows meet. Under all three conditions, it is possible to control or eliminate the transient surge by immediately increasing the flow pressure and over-powering or washing the transient surge off the riding surface. However, there comes a point where the build-up of water volume is so great that for all practical purposes over-powering is either impossible, or at best, a costly solution to a problem capable of less expensive solution. Such less expensive solution is possible by the introduction of vents.

21

Two classes of vent mechanisms are identifiable. The first class, self-clearing inclines, are used to clear transient surges from inclined surfaces. FIG. 13a, 13b, and 13c show in time lapse sequence how the design of self-clearing incline 64 operates to solve the problem of a pressure/flow lag during start-up. In FIG. 13a water flow 39 has commenced issue in an uphill direction from water source (not shown) in direction 38. As water flow 39 moves up front surface 47, the leading edge of water flow is slowed down by a combination of the downward force of gravity and friction with front surface 47, whereupon, it is overtaken and pushed by the faster and stronger flow of water that subsequently issued from the water source. The result of this flow dynamic is that a transient surge 68 begins to build. However, as transient surge 68 builds, it reaches the height of low side edge 50b' and commences to spill over onto back surface 46. FIG. 13b shows this start procedure moments later wherein the water pressure/flow rate from the water source has increased and transient surge 68 has moved further up the incline. FIG. 13c shows the final stage of start-up wherein the transient surge has been pushed over the top of Down Stream Ridge Line 48 and water flow 39 now runs clear. Similar to the start-up procedure, when a lower speed rider encounters the higher speed water, or when an accumulative build-up of water results from a spilling wave, a transient surge may occur. In like manner, the transient surge will clear by spilling off to the lowered side accordingly.

The second class of vent mechanism, swale vents, are used to assist in clearing transient surges from tunnel wave generators. FIG. 14a and 14b show in time lapse sequence how the design of swale 67 operates to solve identical problems as suffered by the inclined surfaces with channel walls. In FIG. 14a water flow 39 has commenced issue in an uphill direction from water source (not shown) in direction 38. Transient surge 68 begins to build. However, as transient surge 68 builds, it commences to vent into swale 67, thus, permitting tunnel wave 42 to properly form as shown in FIG. 14b.

#### Description and Operation of the Omni-Wave

FIG. 15 depicts a preferred embodiment herein named an Omni-wave 69 comprised of Self-Clearing Incline 64 which is interconnected and continuous with Self-Clearing Tunnel Wave 66.

FIG. 16a, FIG. 16b, FIG. 16c, FIG. 16d, FIG. 16e and FIG. 16f illustrates Omni-Wave 69 in operation. A unique feature of Omni-Wave 69 is its unique flow forming shape can permit (by way of a progressive increase of the net head of the water flow) the transformation of super-critical water flow 39 that originates from a water source (not shown) in direction 38 to a stationary spilling wave 70 along the entire forming means (as illustrated in FIG. 16a); to a stationary spilling wave 70 with Self Clearing Incline 64 flow (as illustrated in FIG. 16b); to a Self-Clearing Incline 64 and Self-Clearing Tunnel Wave 66 flow (as illustrated in FIG. 16c). This progressive wave forming method is hereinafter referred to as the "Wave Transformation Process". The Omni-Wave and the Wave Transformation Process will offer an improved environment for the performance of surfing and water skimming maneuvers. FIG. 16d shows surfer 63 and rider 41 on Self-Clearing Tunnel Wave 66 and Self-Clearing Incline 64 respectively. FIG. 16e shows surfer water skimming kneeboarder riding upon stationary spilling wave 70, FIG. 16f shows inner-tube rider 72 and water skier 73 on stationary

5,393,170

22

spilling wave 70 and Self-Clearing Incline 64 respectively.

#### Description and Operation of the Fluid Half Pipe

Turning to FIG. 17 wherein an apparatus is revealed that will enable riders to perform surfing and water skimming maneuvers in a format heretofore unavailable except by analogy to participants in the separate and distinct sports of skateboarding and snowboarding, to wit, half-pipe riding. Fluid Half-Pipe 74, comprises a method and apparatus for generating a body of water 80 with a stable shape and an inclined surface thereon substantially in the configuration of a half-pipe with the opening of said half-pipe facing in an upwards direction. The water 81 which supplies said body of water flows over the leading edge 82 of the half-pipe flow forming means 89 and down one side (hereinafter referred to as the down-flow-side 83), in a direction perpendicular to the length of said half-pipe, across an appropriate sub-equidyne flat section 84, and up and over the other side of the half-pipe (hereinafter referred to as the up-flow-side 85), across the trailing edge 86, and into an appropriate receiving pool 87 or other suitably positioned Fluid Half Pipe or attraction. A rider 88a enters the flow at any appropriate point, e.g., sub-equidyne flat section 84, wherein as a result of his initial forward momentum of entry, the excessive drag of his water-skimming vehicle, and the added drag of the riders weight induced trim adjustments to his riding vehicle, said rider (now 88b) is upwardly carried to a supra-critical area in the upper regions of up-flow-side 85 near the half pipe's trailing edge 86, wherein as a result of the force of gravity in excess of the drag force associated with the riding vehicle and the riders own weight trim adjustments to reduce drag, rider (now 88c) hydroplanes down the up-flow-side 85, across the sub-equidyne flat 84, and performs a turn on down flow side 83 to return to up-flow-side 85 and repeat cycle.

As can be appreciated by those skilled in the art, Fluid Half-Pipe 74 will offer its participants a consistent environment in which to perform known surfing and water skimming maneuvers, and due to the combination of up-side-flow, flat, and down-side-flow a unique environment in which to perform new maneuvers unachievable on existing wave surfaces.

The preferred embodiment for the breadth of the flow forming means 89 of Fluid Half-Pipe 74 approximates Connected Structure 57 joined to its mirror image at the midpoint of sub-equidyne 62. It is preferred that said width remain constant for the length of flow-forming means 89, however, variations in width with resultant variations in cross-sectional shape are possible. The limitations on minimum and maximum width is a function of ones ability to perform surfing and water skimming maneuvers. If the flow forming means is too narrow, a rider would be unable to negotiate the transition from the up-flow side 85 to the down-flow-side 83 or vice versa. If too wide, a rider would not be able to reach or utilize the down-flow side 83 to perform surfing and water skimming maneuvers.

A preferred embodiment for the length of the flow forming means of Fluid Half-Pipe 74 is at a minimum a length sufficiently wide to perform surfing and water skimming maneuvers thereon, and at a maximum a function of desire and/or budget.

A preferred embodiment for the cross-sectional shape of the up-flow side's flow forming means has been shown in FIG. 9b and discussed above. FIG. 9b illus-

23

5,393,170

trated a detailed cross-section of Connected Structure 57, with sub-equidyne area 62, equilibrium zone 60, and supra-equidyne area 58. Caution must be taken in the design of the up-flow-side 85 supra-equidyne area to insure proper water flow up and over the trailing edge 86. Excessive steepness or height that results in untimely or improperly located spilling or tunneling waves can result in an excessive build-up of turbulent white water in the sub-equidyne flat area 84 which may culminate in complete deterioration of the up-side-flow. However, since advanced riders, in order to maximize speed and perform certain maneuvers, e.g., aerials, prefer a steep supra-critical area that approaches or exceeds vertical then it is preferred that spilling or tunnel wave formation (if any) be limited to areas adjacent the side openings of half-pipe 74, and that the majority middle half pipe 74 be substantially the shape as illustrated in FIG. 9b with supra-equidyne configuration 58a.

Generally, the elevation of half-pipe 74 leading edge 82 will exceed its line-of-flow position on half-pipe 74 trailing edge 86. This differential in elevation will insure that the water of said body of water 81 will have sufficient dynamic head to overcome all internal and external friction that may be encountered in its circuit down, across, up, and over flow forming means 89. The preferred ratio by which the down-flow-side exceeds the up-flow-side ranges from a minimum of ten to nine to a maximum of ten to one. It is also preferred that the respective leading and trailing edge 82 and 86 remain at constant elevations along the length of the half-pipe. Variations in elevation are possible, however, source pool water 81 dynamics, receiving pool water 87 dynamics, and maintenance of line of flow dynamic head must be accounted for.

In cross-sectional profile, a standard configuration for Fluid Half Pipe 74 is illustrated in FIG. 18a. In this standard configuration the cross-sectional elevation, width, and depth remains constant for the length of half-pipe 74. FIG. 18b illustrates an asymmetrical configuration, wherein, the leading and trailing edges 82 and 86 remain at constant elevations and the width between trailing edges remains constant, however, the distance between trailing edges and the flat sub-equidyne section 84 continues to increase at a constant rate of fall. The object of this particular asymmetrical embodiment is to increase throughput capacity for half-pipe 74 as the result of rider movement in the direction of fall due to the added vector component of gravity force ascribed to the weight of the rider in the direction of fall.

The preferred velocity of water in the subject invention is substantially a function of the overall drop in distance from leading edge 82 to the flat area 84. Consequently, previously discussed preferences in the overall height of the Connected Structure dictate the preferred water velocity. Such velocity can be calculated in accordance with Bernoulli's equation  $v = \sqrt{2gz}$  where  $v$  is the velocity in feet per second,  $g$  is gravity  $\text{ft}/\text{sec}^2$  and  $z$  = vertical distance dropped in feet.

The preferred depth of water is that which is required to perform surfing and water skimming maneuvers. For purposes of Half Pipe 74 the minimum depth is 2 cm. and the maximum depth is whatever one might be able to afford to pump. Except the desirable spilling/tunnel wave formation adjacent a side-opening of half-pipe 74, an additional preference is that the water avoid excessive turbulence that results from a hydraulic jump

24

which occurs when the velocity of a sheeting body of water exceeds a certain critical velocity at a certain minimum depth.

Variations in the breadth and longitudinal movement of the body of water that flows upon the half-pipe can result in enhancements to rider through-put capacity for the Fluid-Half Pipe. FIG. 19 depicts a half-pipe configured flow forming means 89. A stably shaped body of water 80a is situated on one side 89a of said flow forming means. The water 81 which supplies said stably shaped body of water is limited by a dam 91a to just one-half of the flow forming means 89. Riders 88a, b, c and d enter the flow at any appropriate point, e.g., the sub-equidyne flat section 84 and perform water skimming maneuvers thereon. As shown in FIG. 19, the water skimming maneuvers are performed using an inner-tube type vehicle. After an elapsed period of time, e.g., several minutes, a dam 91b is positioned to block the water 81 which supplies the stably shaped body of water 80a on side 89a of said flow forming means. Upon blockage of the source of water, the stably shaped body of water 80a soon ceases to exist on side 89a of said flow forming means. Consequently, the riders 88a, b, c and d drift to the sub-equidyne section 84 and can easily exit. Simultaneously with, or shortly after the blockage by dam 91b, dam 91a opens and water 81 begins to flow over flow forming means 89b, whereupon forming a stably shaped body of water 80b that remains situated on side 89b. Riders 88e, f, and g enter the flow and commence to perform water skimming maneuvers for their allotted time span, whereupon dam 91a is re-positioned and the cycle is set to repeat.

FIG. 20 illustrates super-critical water flow 39 originating from a water source (not shown) moving in direction 36 to produce a conforming upward flow over front face 78. Dividers 79 provide separation for the individual riders 77a, 77b, and 77c and to prevent a "jet wash" phenomenon that can result in loss of a rider's flow. This "jet wash" phenomenon occurs when a rider who is positioned in the equilibrium or supra-equidyne area of a thin sheet flow gets his flow of water cut off by a second rider positioned with priority to the line of flow. The cutting off of water occurs in thin sheet flow situations due to the squeegee effect caused by the second rider's skimming vehicle.

As will be recognized by those skilled in the art, certain modifications and changes can be made without departing from the spirit or intent of the present invention. For example, the curvatures given as examples for the Connected Structure do not have to be geometrically precise; approximations are sufficient. The same is true of limits in angles, radii and ratios. The temperature and density of the water will have some difference although the range of temperatures in which surfer/riders would be comfortable is fairly limited.

The terms and expressions which have been employed in the foregoing specifications are used therein as terms of description and not of limitation, and there is no intention, in the use of such terms and expressions, of excluding equivalents of the features shown and described, or portions thereof, it being recognized that the scope of the invention is defined and limited only by the claims which follow.

It is claimed:

1. A water ride facility for amusement parks, water parks and the like, wherein a user rides on a sheet flow of water flowing in a predetermined direction onto said water ride facility, comprising:

5,393,170

25

a substantially stationary riding surface having a substantially horizontal portion, followed in the direction of said flow of water by a concave upwardly inclined portion, and a substantially upwardly convex ridge portion; and

said sheet flow of water on said riding surface having a predetermined velocity and volume sufficient to cause said flow to substantially conform to the contours of said riding surface, said flow flowing onto said horizontal portion, and onto said inclined portion, and then onto said convex ridge portion, wherein a user can ride over said portions on said flow of water.

2. The water ride facility of claim 1, wherein said inclined portion of said riding surface comprises a first sub-portion followed in the direction of said flow by a second sub-portion, the angle of inclination of said first sub-portion being less than that of said second sub-portion.

3. The water ride facility of claim 1, wherein one side of said riding surface is generally at a higher elevation than another side of said riding surface, whereby said riding surface has an inclination in a direction transverse to the direction of said flow.

4. The water ride facility of claim 3, wherein said convex ridge portion forms an upper ridge portion having an inclination transverse to the direction of flow.

5. The water ride facility of claim 4, wherein said flow has a velocity sufficiently high enough to cause said flow to flow over said ridge portion while maintaining a super critical velocity throughout said riding surface.

6. The water ride facility of claim 4, wherein said velocity of said flow of water is reduced such that said flow of water does not maintain a supercritical velocity along the entire width of said riding surface, wherein a portion of said flow due to gravity reaches a subcritical speed adjacent said higher elevation side of said riding surface.

7. The water ride facility of claim 6, wherein said sub-critical flow is self-cleared due to gravity in a direction away from said higher elevation side of said riding surface.

8. A water ride facility for amusement parks, water parks, and the like, wherein a user rides on a flowing body of water, said flowing body of water flowing in a predetermined direction, said facility comprising:

a substantially stationary riding surface having a generally inclined portion extending in the direction of said flow, wherein said flowing body of water travels onto said riding surface and substantially conforms to the contours of said inclined portion of said riding surface; and

a wave-forming structure extending upward from and across said generally inclined portion and having a curved, elevated, and inclined surface thereon, said wave-forming structure having a degree of inclination sufficient to cause said flowing body of water to flow upward and across said wave-forming structure, and due to gravity to reach a subcritical flow such that said body of water forms a spilling wave thereon.

9. The water ride facility of claim 8, wherein said flowing body of water moves at a velocity insufficient to cause it to flow completely over said wave-forming structure, whereby a simulated spilling wave is formed upon which said user can ride.

26

10. The water ride facility of claim 8, wherein said wave-forming structure is shaped with a sufficient degree of inclination and concavity so that said conforming flowing body of water flows onto and upward along said wave-forming structure and by virtue of the force of gravity curves downwardly to form a tunnel wave.

11. The water ride facility of claim 8, wherein said wave-forming structure has a concave curvature in both the vertical and horizontal directions.

12. The water ride facility of claim 8, wherein said wave-forming structure comprises a front face having an angle of inclination which varies within a range of 56-90 degrees.

13. The water ride facility of claim 8, wherein said wave-forming structure has a vertical cross section along a plane extending in the direction of flow which varies along its length, wherein the angle of inclination of said vertical cross section extends upward to the vertical to about 10 degrees past the vertical.

14. The water ride facility of claim 8, wherein said wave-forming structure has an angle of inclination which is sufficiently gradual to avoid separation or deflection of said flow.

15. The water ride facility of claim 8, wherein said wave-forming structure has a height of 1-6 meters.

16. The water ride facility of claim 8, wherein a substantially horizontal portion is located upstream relative to the direction of said flow of water from said generally inclined portion.

17. The water ride facility of claim 16, wherein the length of said substantially horizontal portion of said riding surface in the direction of flow is in the range of 1-4 to 4 times the height of said wave-forming structure.

18. A water ride facility for amusement parks, water parks and the like, wherein a user rides on a flowing body of water, said facility comprising:

a substantially stationary riding surface comprising an inclined portion having an upper generally smooth, convexly shaped ridge, said ridge being generally higher in elevation on one side of said riding surface and generally lower on another side of said riding surface; and

said flow of water substantially conforming to the contours of said riding surface, said flow of water flowing up said inclined portion such that non-equilibrium water-skimming maneuvers may be performed by said user on said riding surface.

19. The water ride facility of claim 18, wherein said upper ridge has an inclination transverse to the direction of said flow of water that is at least 5 degrees from the horizontal extending from the low elevation side to the high elevation side.

20. A water ride facility wherein a user rides on a flowing body of water, said facility comprising:

a substantially stationary riding surface having a first section extending generally along one side of said riding surface, said first section extending upward and having an inclined surface which forms an upper convex ridge portion, said riding surface having a second section extending generally laterally along another side of said riding surface, said second section extending upward to form an elevated wave-forming structure thereon; and

a first portion of said flowing body of water onto said first section of said riding surface and flowing onto said inclined surface such that said body of water flows over said ridge portion, and a second portion of said flowing body of water flowing onto said

27

second section of said riding surface and onto said wave-forming structure such that said body of water reaches a subcritical velocity due to gravity acting on said body of water and forms a spilling wave along said wave-forming structure.

21. The water ride facility of claim 20, wherein said flow of water has a minimal depth and a super critical velocity sufficient to cause said flow of water to flow up said second section of said riding surface and onto said elevated wave-forming structure, whereby said flow conforms to said wave-forming structure and flows upward to form a simulated curling wave.

22. The water ride facility of claim 20, wherein said wave-forming structure comprises an angled concave surface which directs said flow of water up and transversely across said wave-forming structure.

23. The water ride facility of claim 20, wherein said wave-forming structure is formed with a steep inclination which directs said flow of water in an upward direction beyond the vertical, whereby a tunnel wave is formed.

24. A water ride facility for amusement parks, water parks and the like, wherein a user rides on a flowing body of water, said body of water flowing in predetermined direction, said facility comprising:

- a riding surface having a substantially semi-cylindrical shape and being positioned such that an axis of said semi-cylindrical shape of said riding surface is oriented in a substantially transverse direction with respect to the direction of said flowing body of water, said riding surface being positioned such that said flow flows downward along a first upper edge portion of said riding surface and then along a lower portion and then upward along a second upper edge portion of said riding surface and over said upper edge portion; and

said flow of water on said riding surface being injected at a velocity sufficient to cause said flow to substantially conform to said semi-cylindrical shape of said riding surface.

25. The water ride facility of claim 24, wherein said riding surface has a dividing means for separating said riding surface in a direction substantially parallel to the direction of flow.

26. The water ride facility of claim 24, wherein said riding surface is tilted such that one side of said riding surface is higher in elevation than another side, whereby an inclination in a direction transverse to the direction of said flow of water is formed.

28

27. A method for operating a water ride facility, comprising the steps of:

providing a riding surface having a high elevation side and a low elevation side;

flowing a shallow flow of water upon said riding surface with sufficient velocity such that said flow substantially conforms to said low elevation side of said riding surface but does not flow over said high elevation side of said riding surface; comprising the additional step of providing a wave-forming structure on said high elevation side of said riding surface and flowing said shallow flow of water upward onto said wave-forming structure at a velocity insufficient to allow said flow of water to rise above said wave-forming structure due to gravity whereby a spilling wave is formed; and self-clearing the flow of water from said high elevation side to said low elevation side.

28. The method of claim 27, including the additional step of increasing the velocity of said flow of water on said riding surface to enable said flow of water to flow up and over said high elevation side of said riding surface.

29. The method of claim 27, further comprising the step of increasing said velocity to a second velocity which is sufficient to cause said flow of water to flow onto and up said wave-forming structure, whereby by virtue of gravitational forces acting on said flow, a curling tunnel wave is formed on said wave-forming structure.

30. A water ride facility for amusement parks, water parks, and the like, wherein a user rides on a flowing body of water, said facility comprising: a riding surface having a generally half-pipe configuration; and said flowing body of water flowing on said riding surface having a velocity sufficient to cause said flow to flow over a leading edge of said half-pipe configuration so as to form a stable shape substantially conforming to the surface of said half-pipe configuration, wherein said flow flows up and over a trailing edge of said half-pipe so that said user can perform water skimming maneuvers thereon.

31. The water ride facility of claim 30, wherein said riding surface is tilted, whereby an inclination in a direction transverse to the direction of said flow of water is formed.

32. The water ride facility of claim 30, wherein said half-pipe configuration is positioned such that the axis of said half-pipe configuration is generally in a transverse direction relative to the direction of said flow.

\* \* \* \* \*

55

60

65



US005564859A

**United States Patent** [19]  
**Lochtefeld**

[11] **Patent Number:** **5,564,859**  
 [45] **Date of Patent:** **Oct. 15, 1996**

[54] **METHOD AND APPARATUS FOR IMPROVING SHEET FLOW WATER RIDES**

3,802,697 4/1974 Le Mehaute ..... 405/79 X  
 3,913,332 10/1975 Forsman ..... 405/79  
 4,954,014 9/1990 Sauerbier et al. .... 405/79

[76] **Inventor:** **Thomas J. Lochtefeld**, 5508 Pacifica Dr., La Jolla, Calif. 92037

*Primary Examiner*—Dennis L. Taylor  
*Attorney, Agent, or Firm*—Knobbc, Martens, Olson & Bear

[21] **Appl. No.:** **393,071**

[22] **Filed:** **Feb. 23, 1995**

[57] **ABSTRACT**

**Related U.S. Application Data**

[63] Continuation of Ser. No. 74,300, Jun. 9, 1993, Pat. No. 5,393,170, which is a continuation of Ser. No. 577,741, Sep. 4, 1990, Pat. No. 5,236,280, which is a continuation-in-part of Ser. No. 286,964, Dec. 19, 1988, Pat. No. 4,954,014, which is a continuation-in-part of Ser. No. 54,521, May 27, 1987, Pat. No. 4,792,260.

An amusement apparatus for water sports activities wherein a flowing body of water is provided. The water moves across an inclined, declined or horizontal riding surface upon which the velocity, volume and gravitational dynamics of the flowing body of water is such that a rider may perform water skimming/simulated surfing maneuvers thereon. Composite structures with horizontal and inclined surfaces and varying flow velocity over time across specifically shaped structures permit water skimming/simulated surfing maneuvers on unbroken, spilling or tunnel type wave forms. Asymmetry in the downstream ridge line of an inclined surface allows spilling type wave formations as well as facilitating the removal of a transient surge. A novel fluid "half-pipe" waveform is also introduced.

[51] **Int. Cl.<sup>6</sup>** ..... **A63B 69/00; A63G 31/16; E02B 3/00**  
 [52] **U.S. Cl.** ..... **405/79; 405/52**  
 [58] **Field of Search** ..... **405/79, 52, 21; 4/491; 472/13, 128, 129**

[56] **References Cited**

**U.S. PATENT DOCUMENTS**

3,557,559 1/1971 Barr ..... 405/79

**44 Claims, 19 Drawing Sheets**

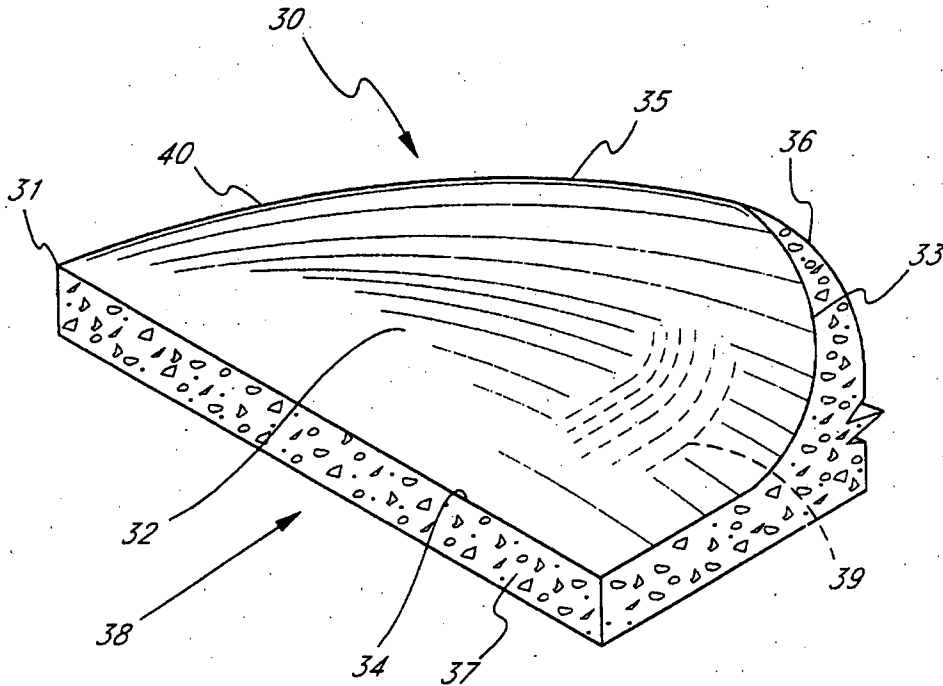

U.S. Patent

Oct. 15, 1996

Sheet 1 of 19

5,564,859

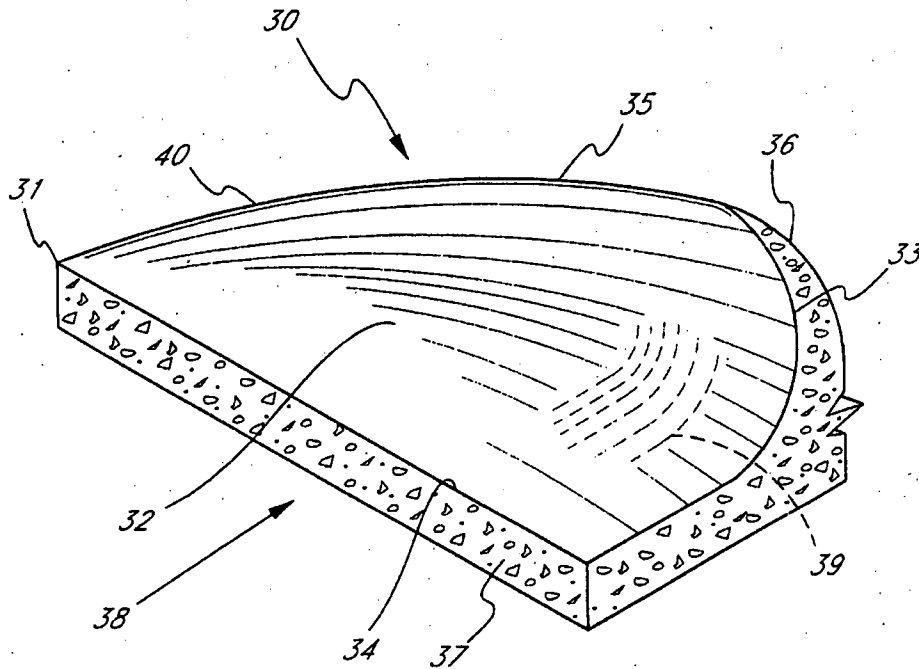

FIG. 1

U.S. Patent

Oct. 15, 1996

Sheet 2 of 19

5,564,859

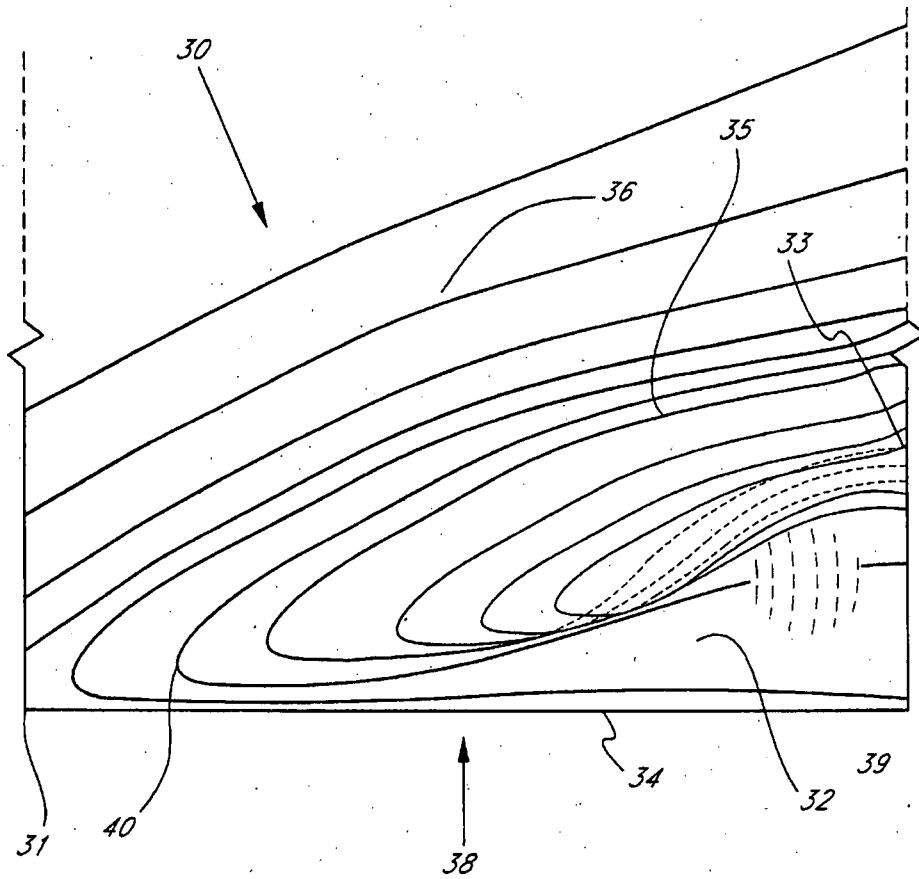

FIG. 2



U.S. Patent

Oct. 15, 1996

Sheet 3 of 19

5,564,859

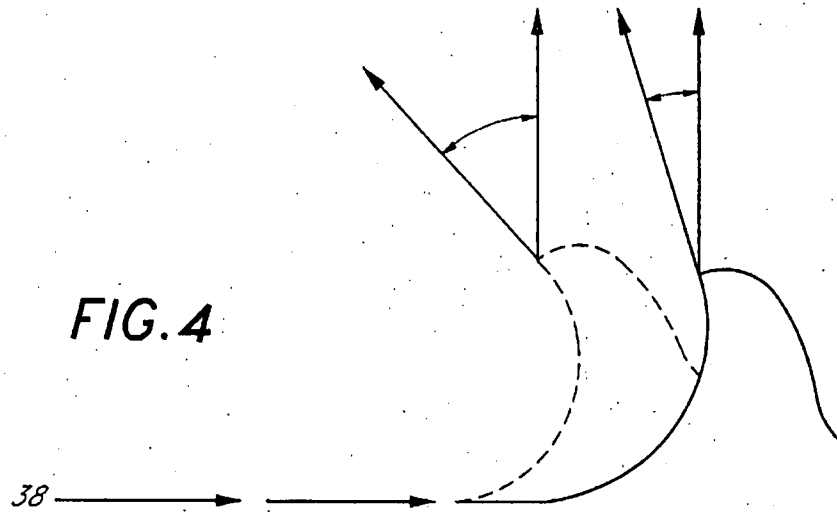
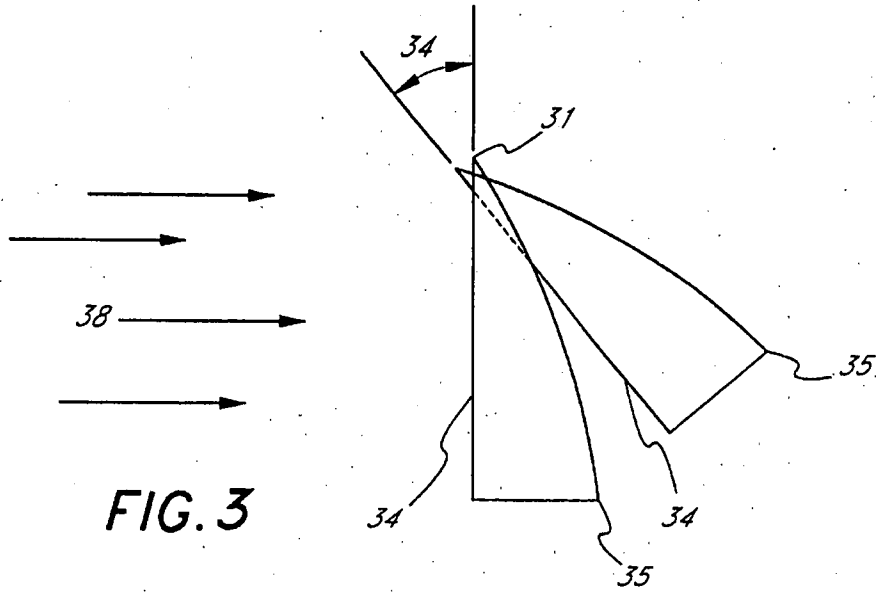

U.S. Patent

Oct. 15, 1996

Sheet 4 of 19

5,564,859

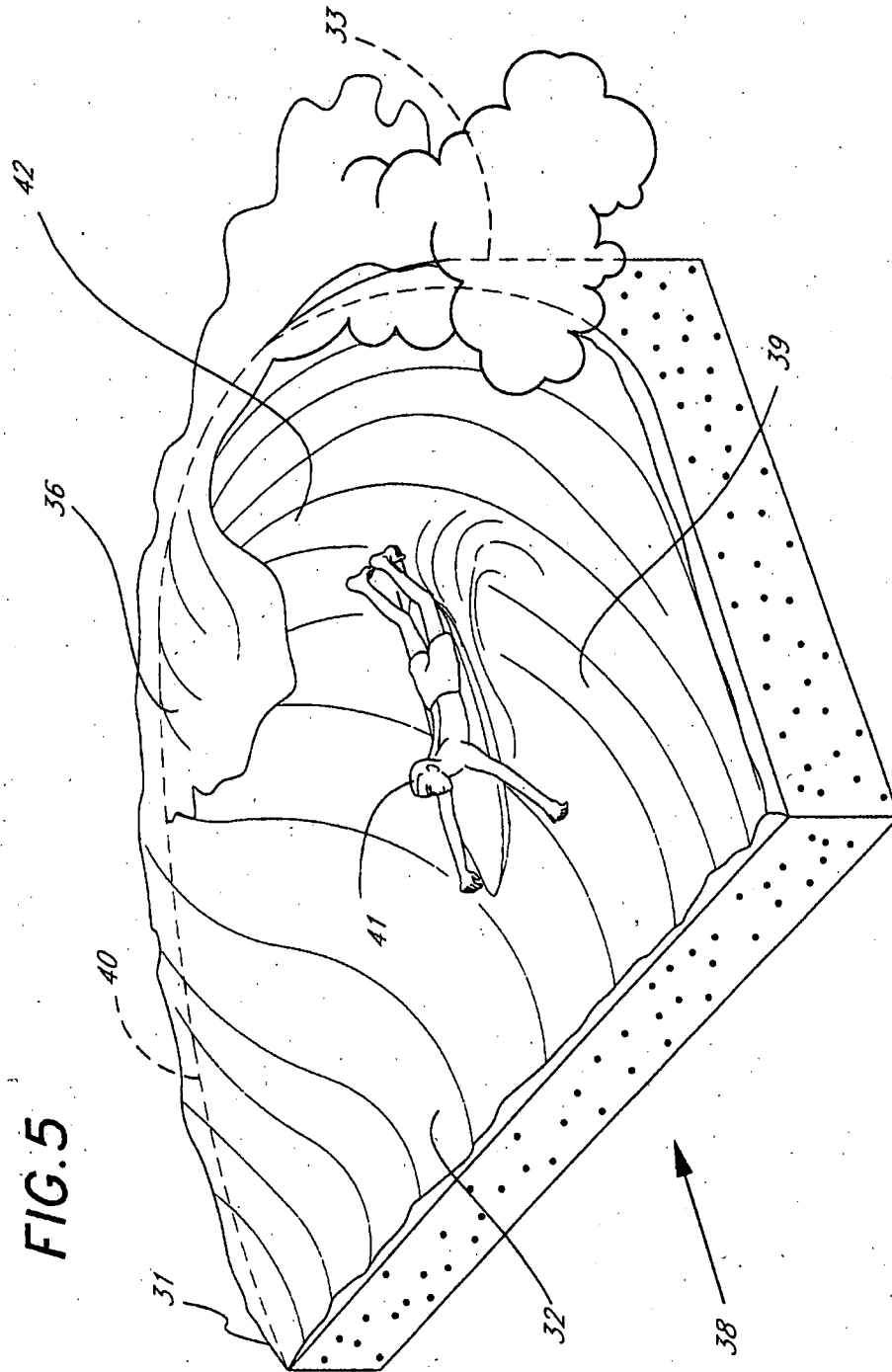

FIG. 5

U.S. Patent

Oct. 15, 1996

Sheet 5 of 19

5,564,859

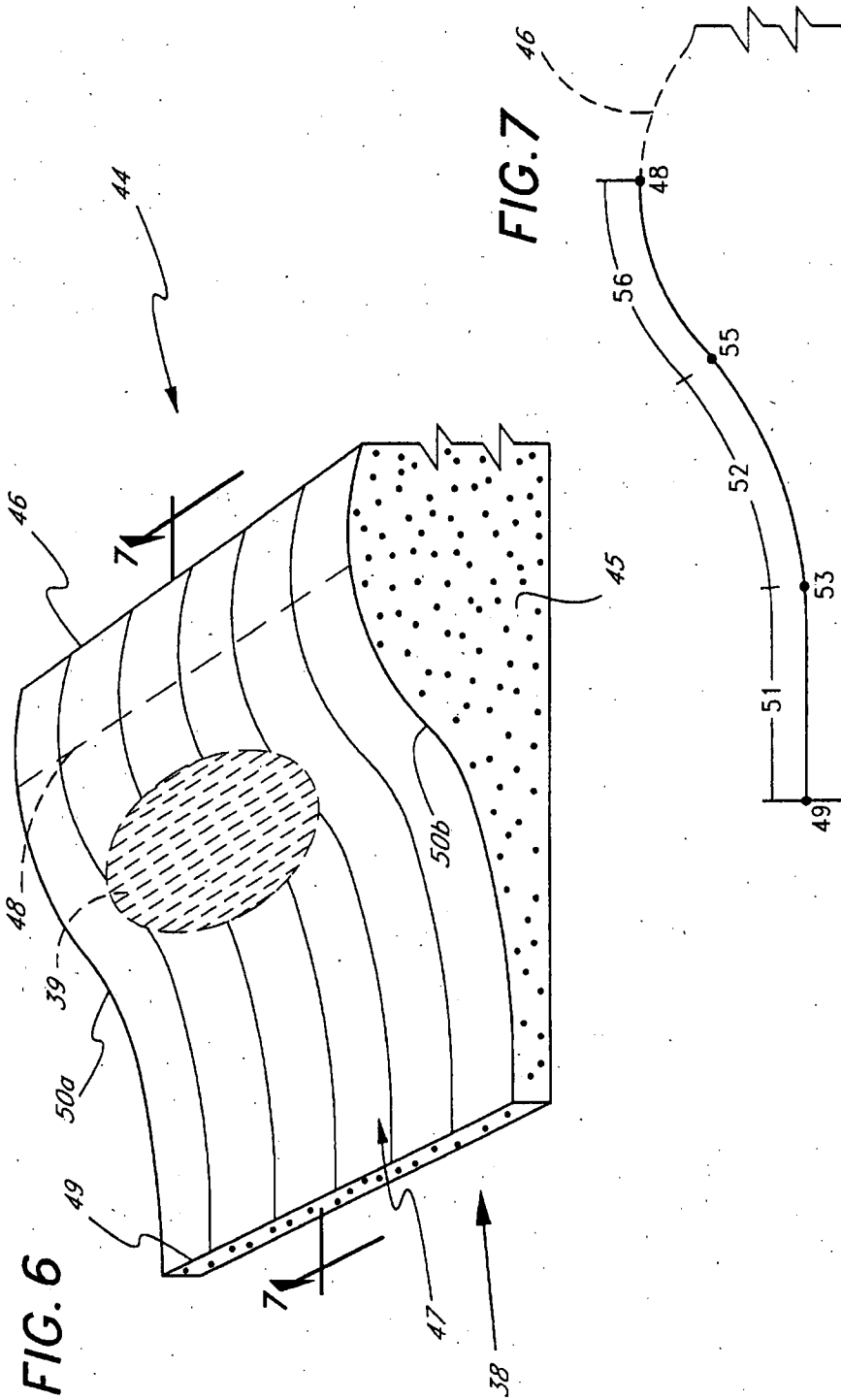

U.S. Patent

Oct. 15, 1996

Sheet 6 of 19

5,564,859

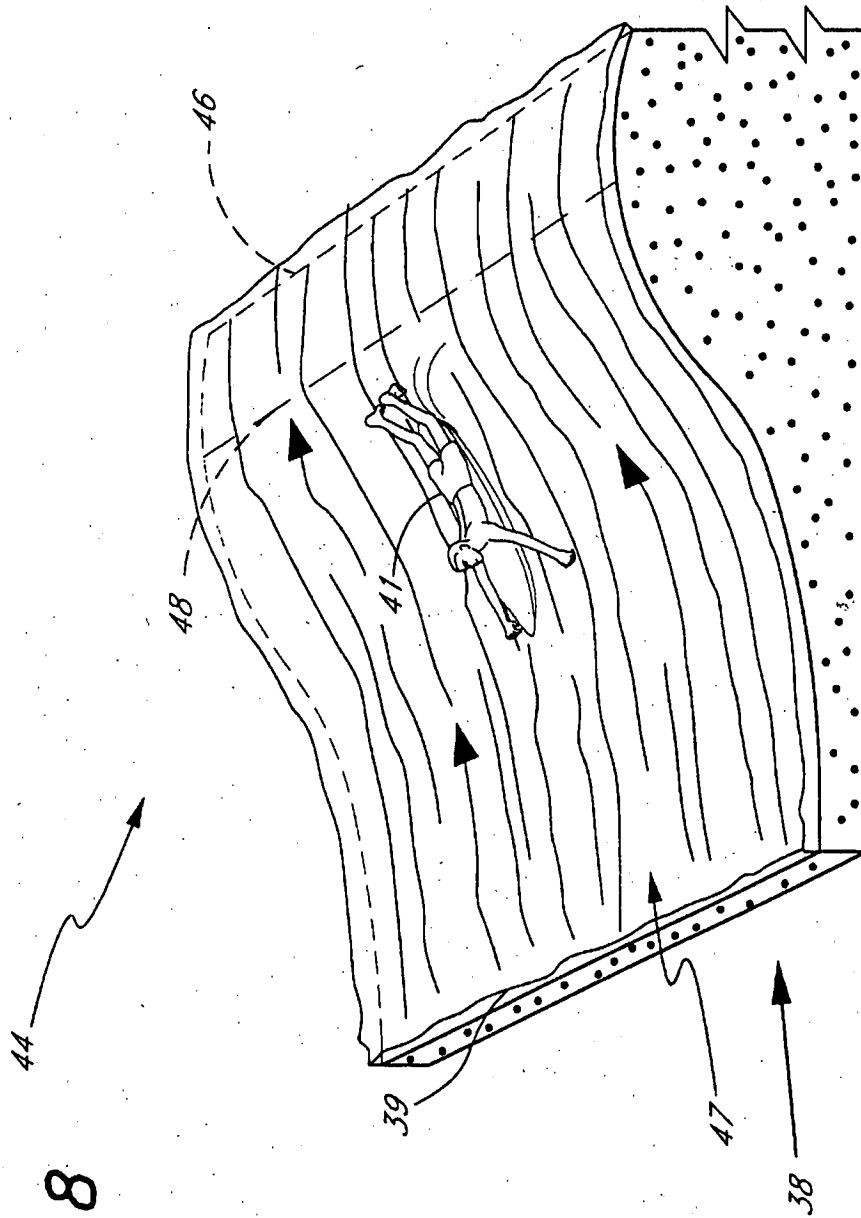

FIG. 8

U.S. Patent

Oct. 15, 1996

Sheet 7 of 19

5,564,859

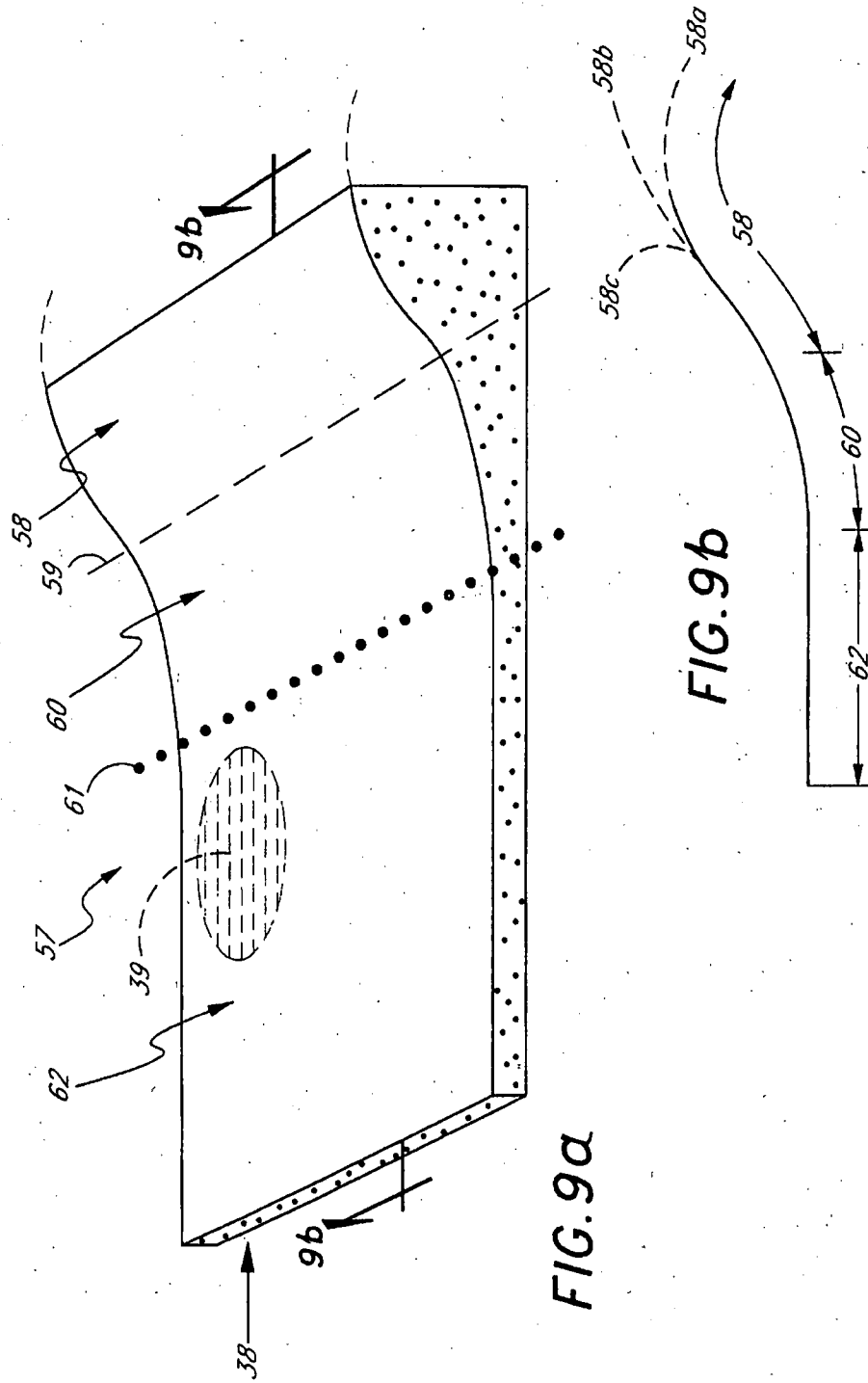

U.S. Patent

Oct. 15, 1996

Sheet 8 of 19

5,564,859

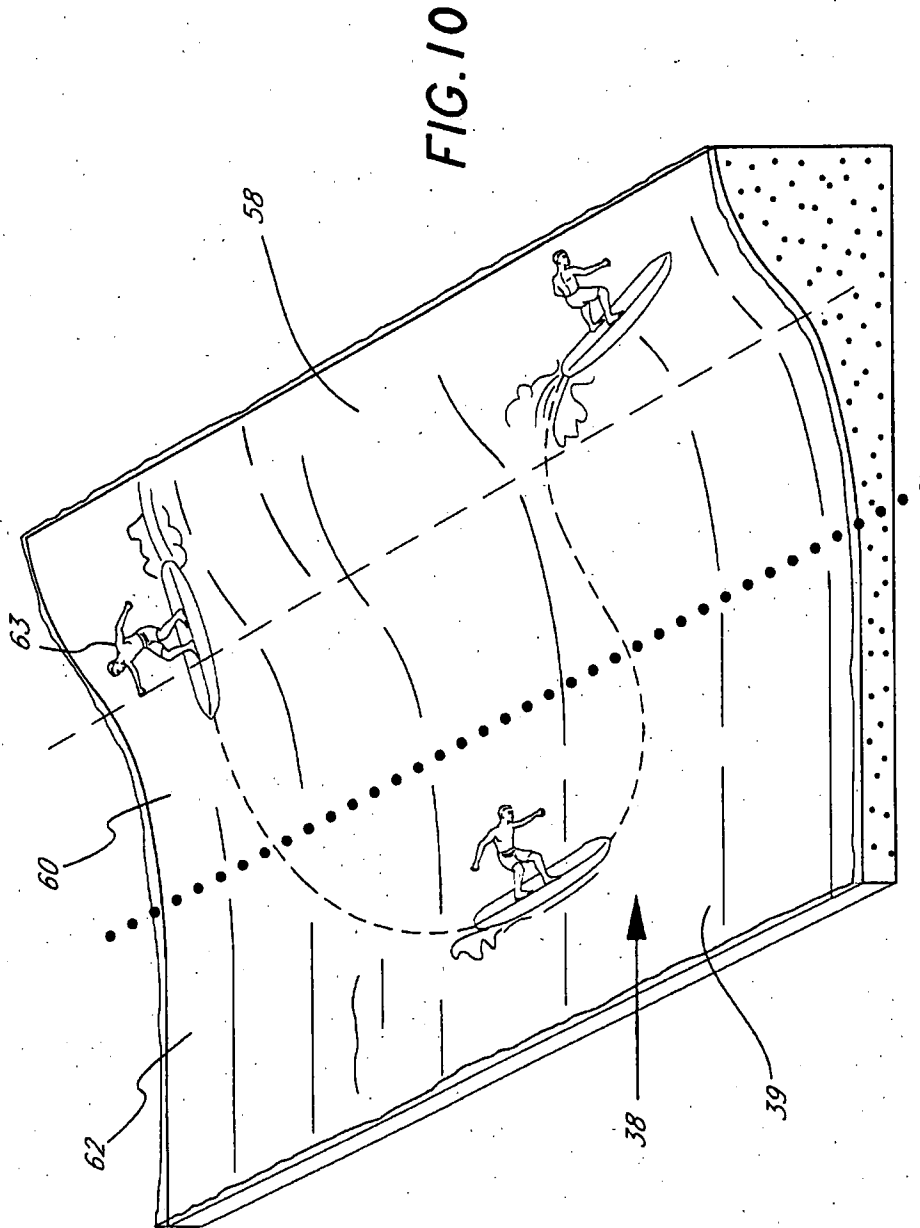

U.S. Patent

Oct. 15, 1996

Sheet 9 of 19

5,564,859

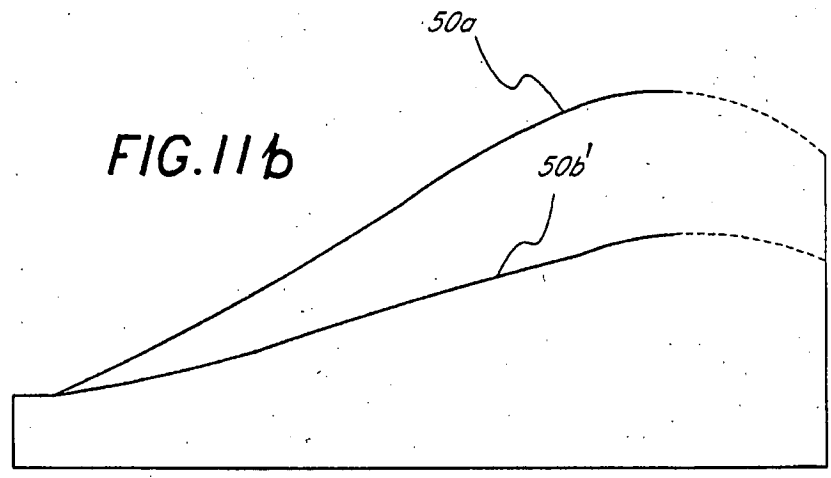
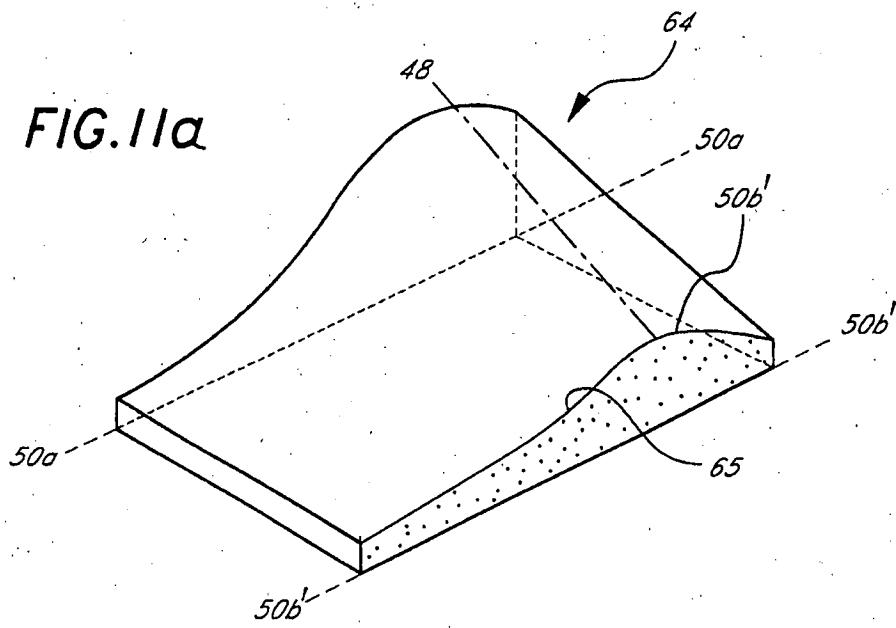

U.S. Patent

Oct. 15, 1996

Sheet 10 of 19

5,564,859

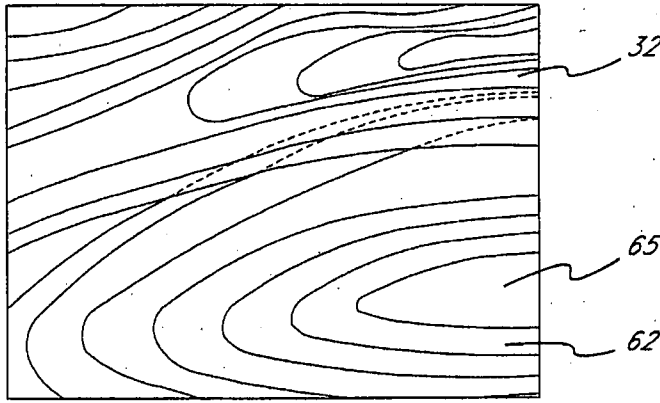

FIG. 12

FIG. 14a

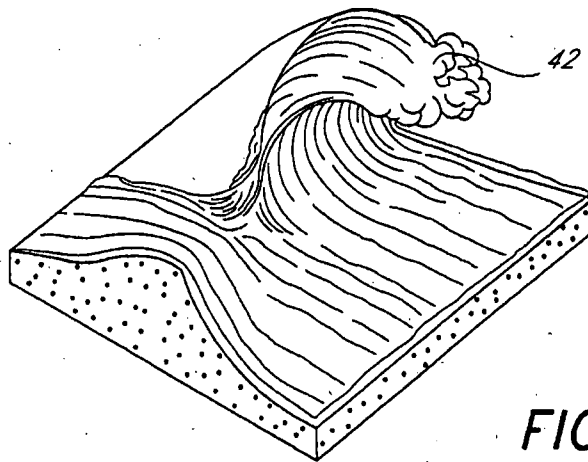
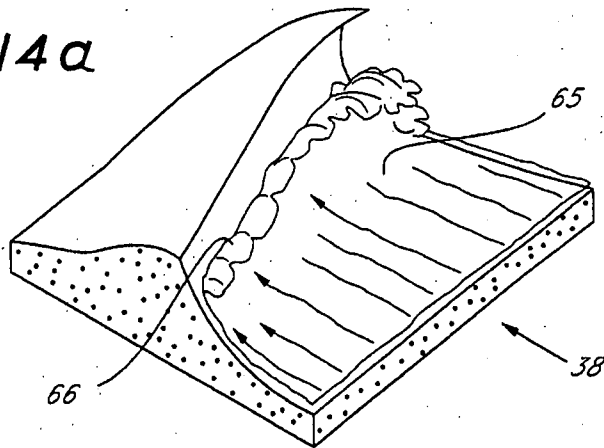

FIG. 14b



U.S. Patent

Oct. 15, 1996

Sheet 11 of 19

5,564,859

FIG. 13a

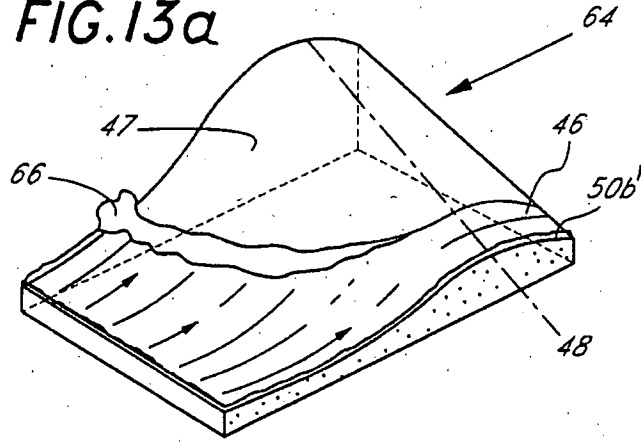

FIG. 13b

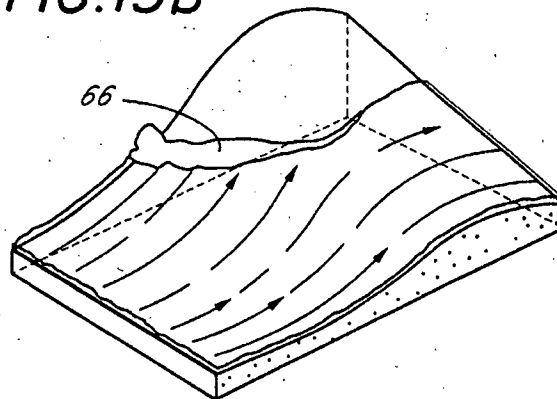
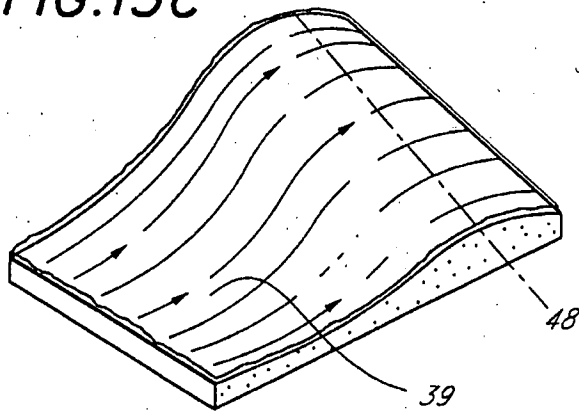

FIG. 13c



U.S. Patent

Oct. 15, 1996

Sheet 12 of 19

5,564,859

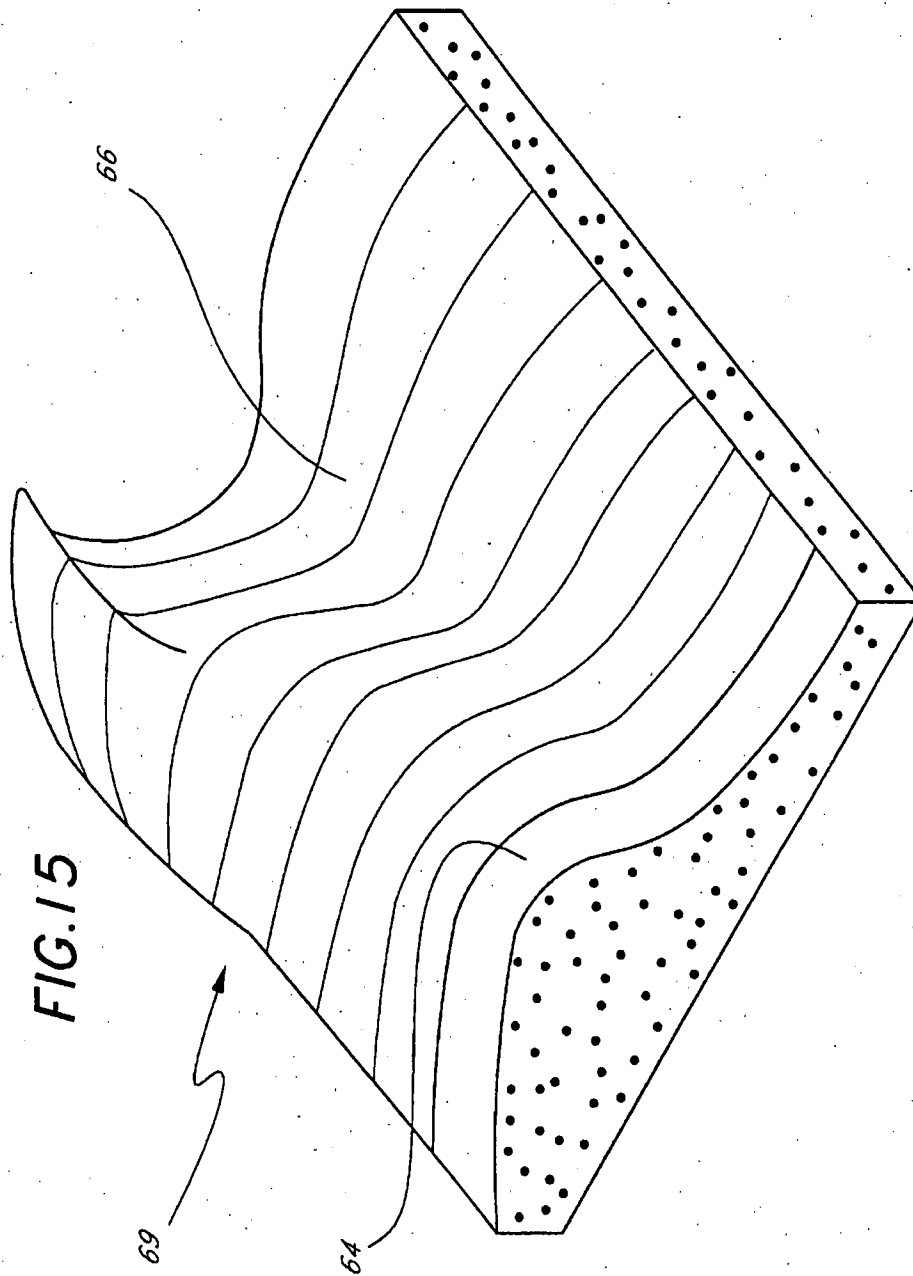

U.S. Patent

Oct. 15, 1996

Sheet 13 of 19

5,564,859

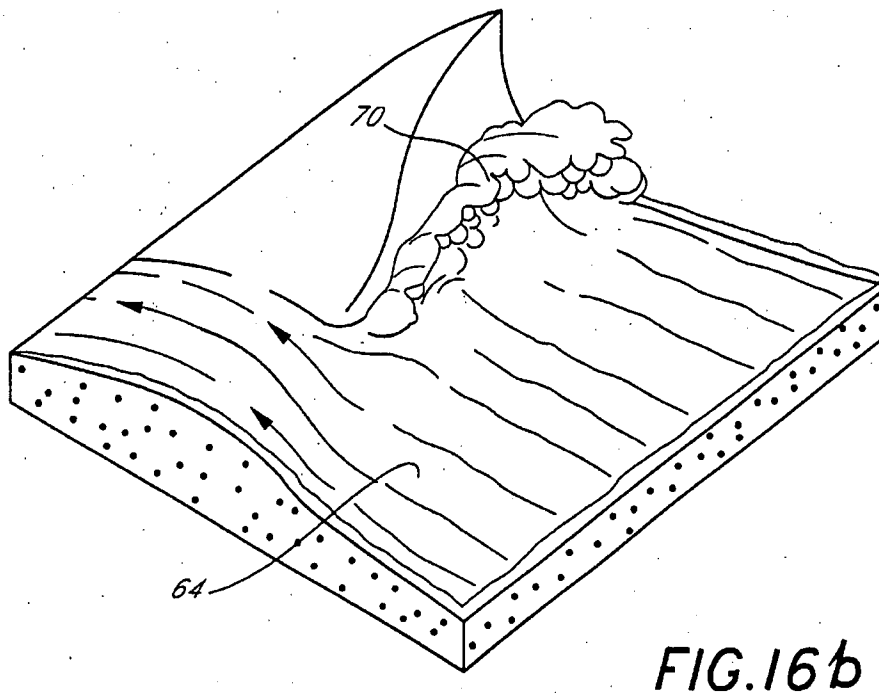
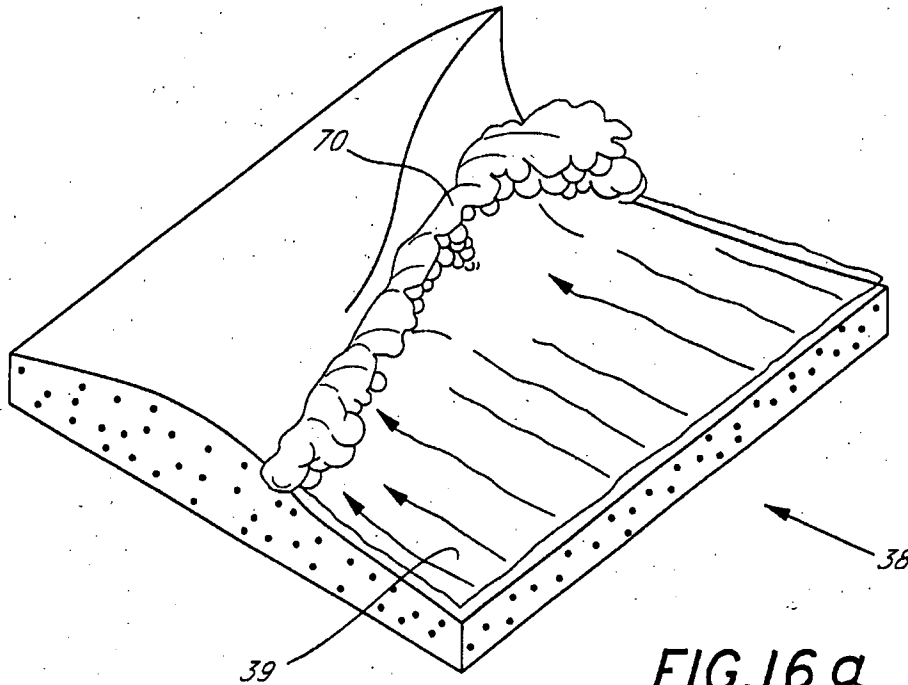

U.S. Patent

Oct. 15, 1996

Sheet 14 of 19

5,564,859

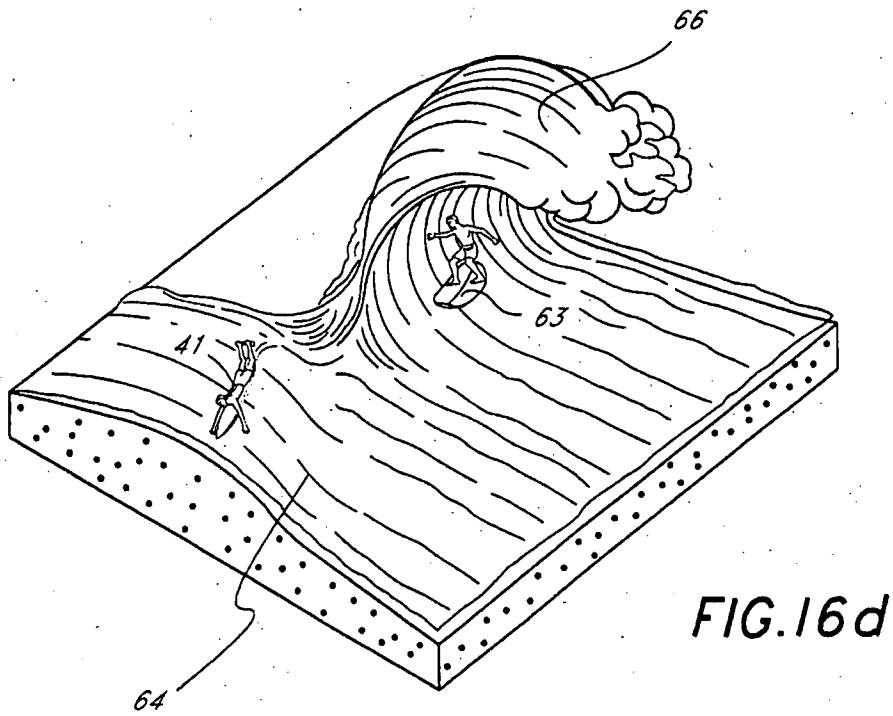
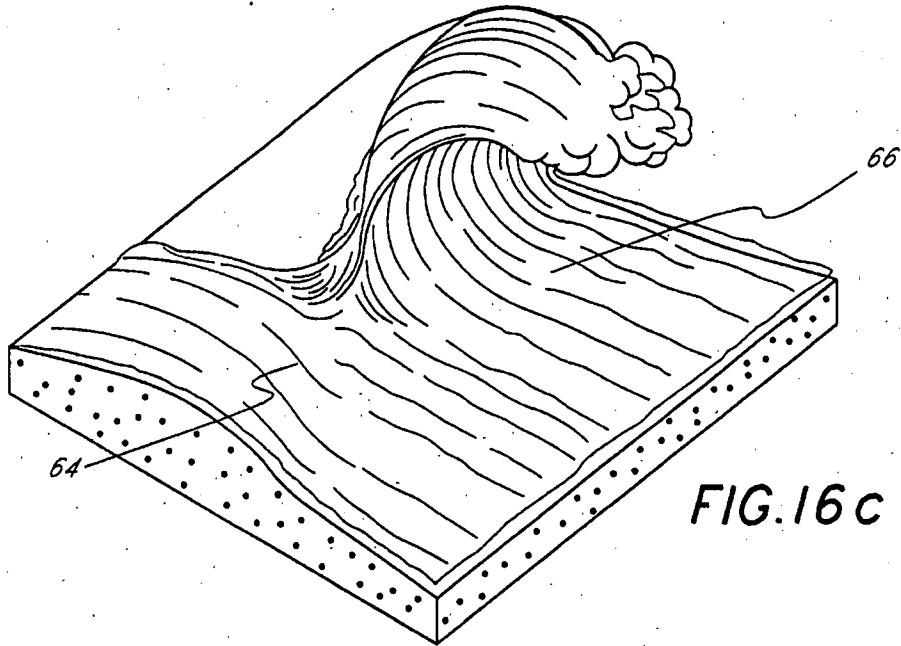

U.S. Patent

Oct. 15, 1996

Sheet 15 of 19

5,564,859

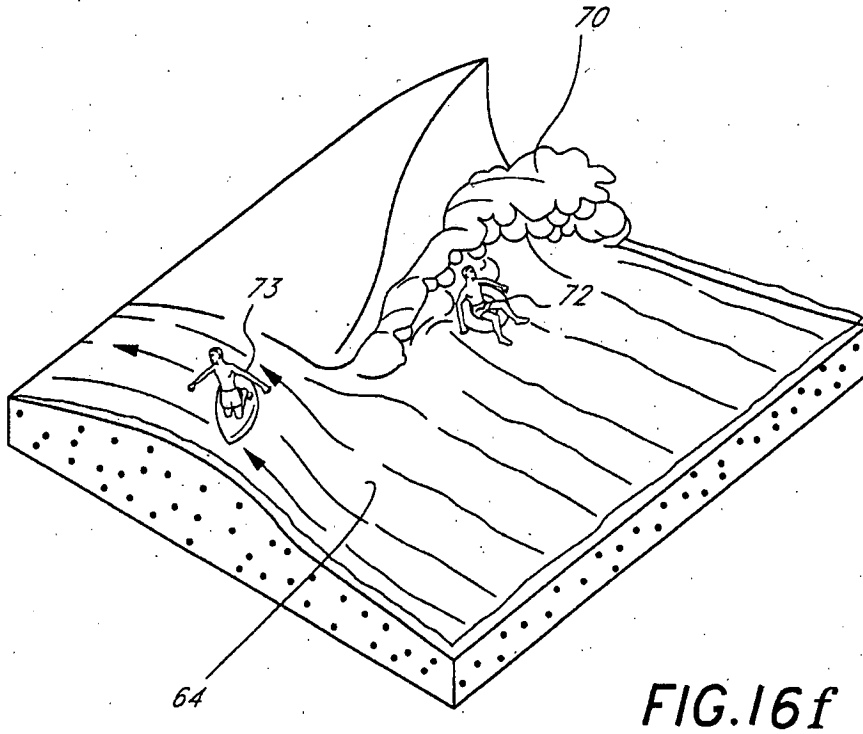
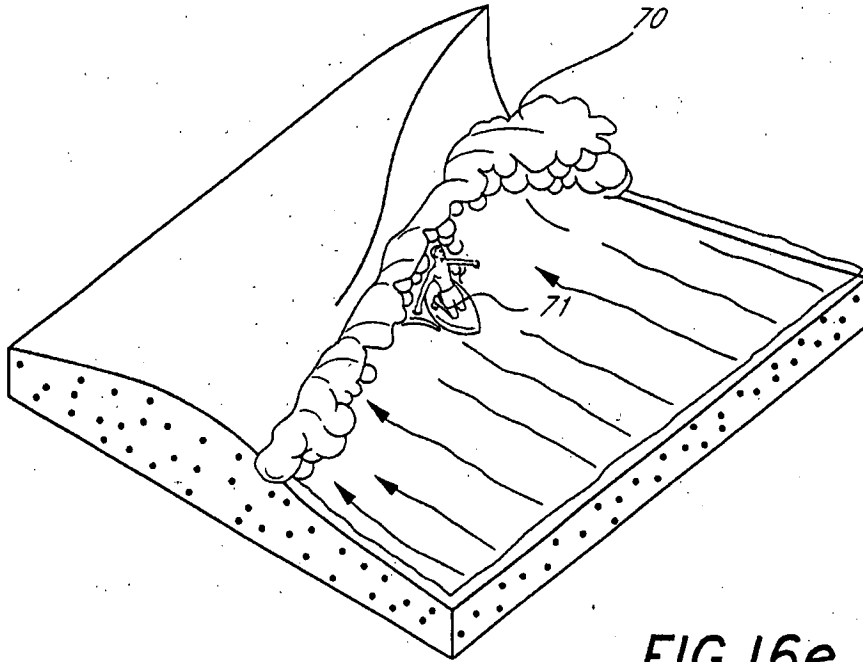

U.S. Patent

Oct. 15, 1996

Sheet 16 of 19

5,564,859

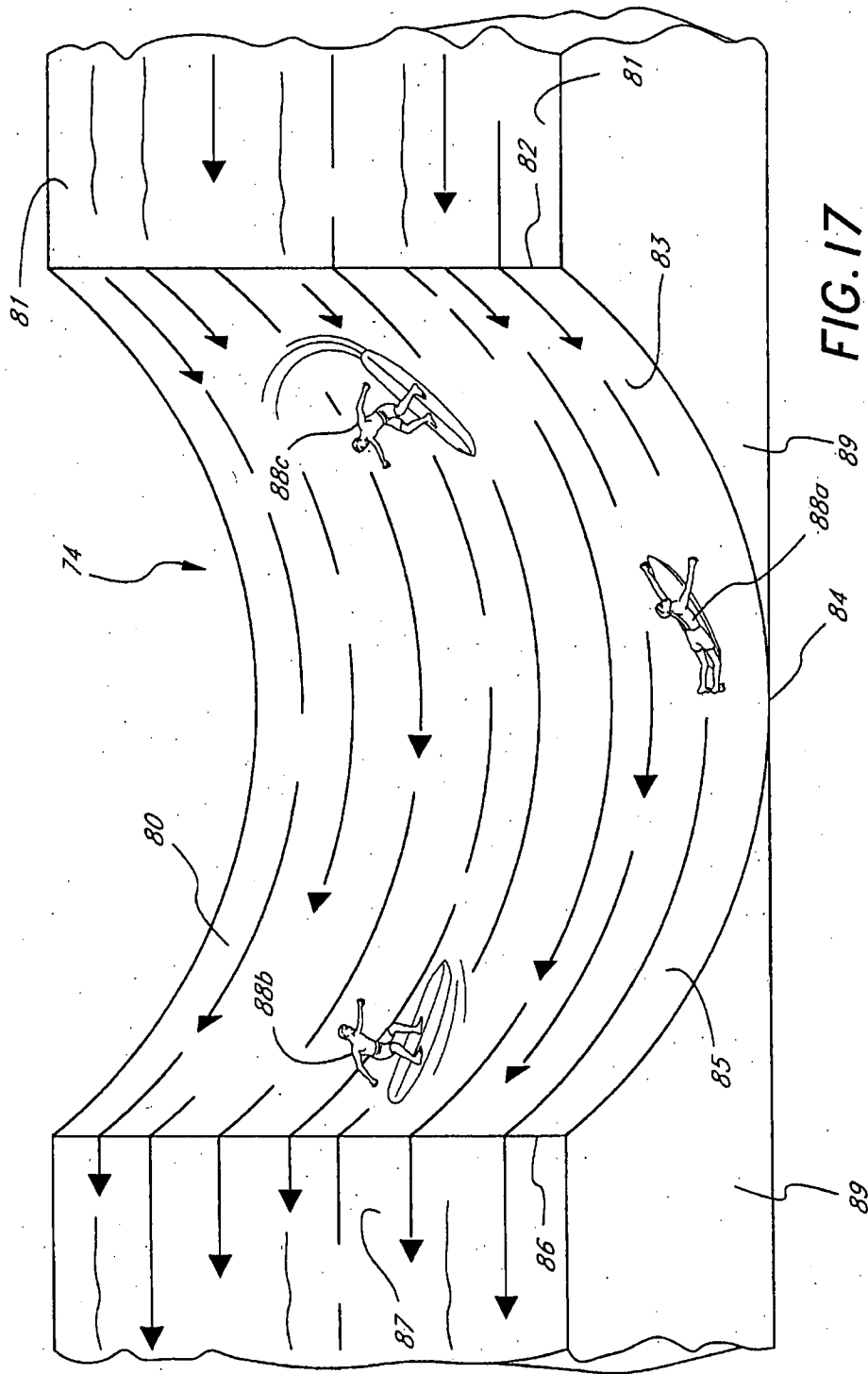

Exhibit 3

U.S. Patent

Oct. 15, 1996

Sheet 17 of 19

5,564,859

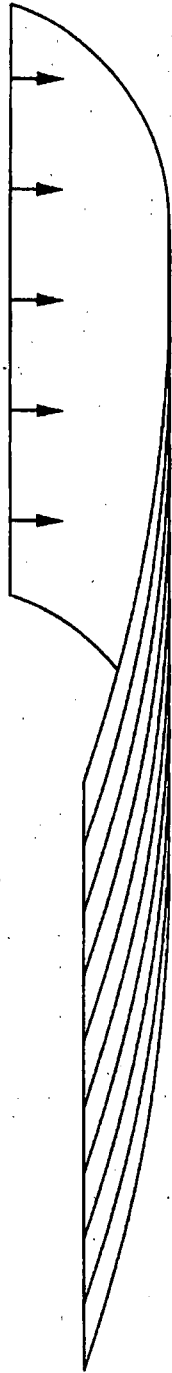

FIG. 18 a

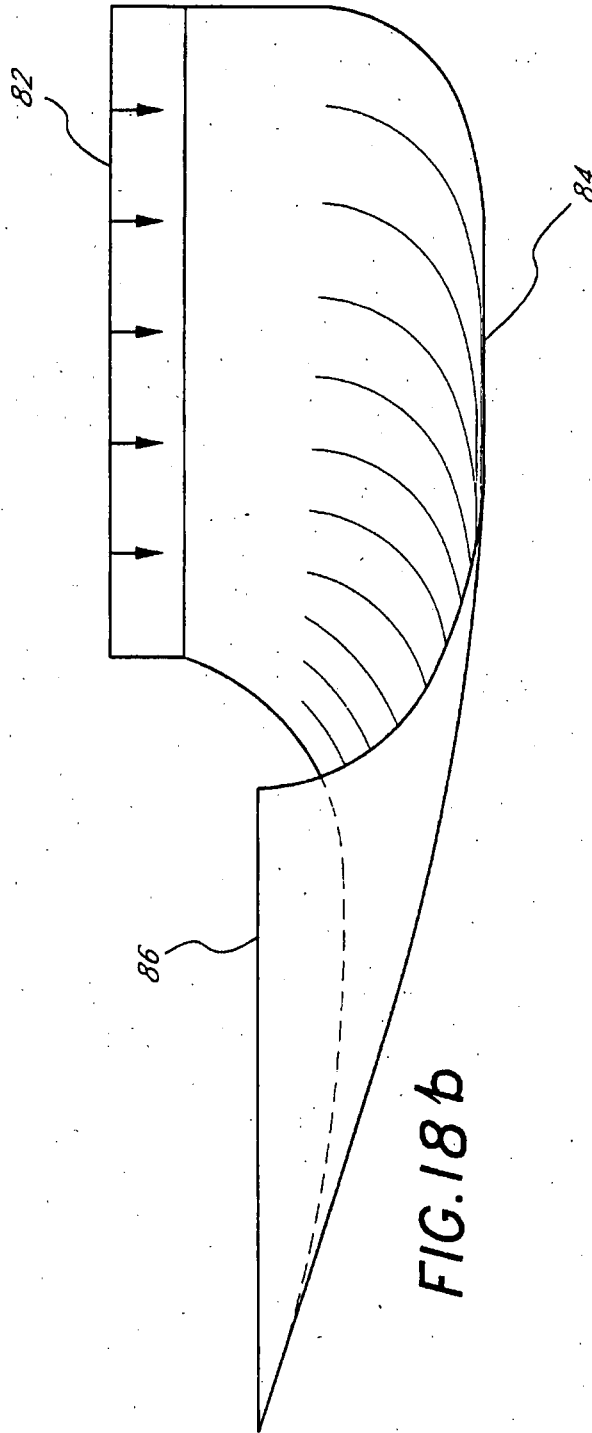

FIG. 18 b

U.S. Patent

Oct. 15, 1996

Sheet 18 of 19

5,564,859

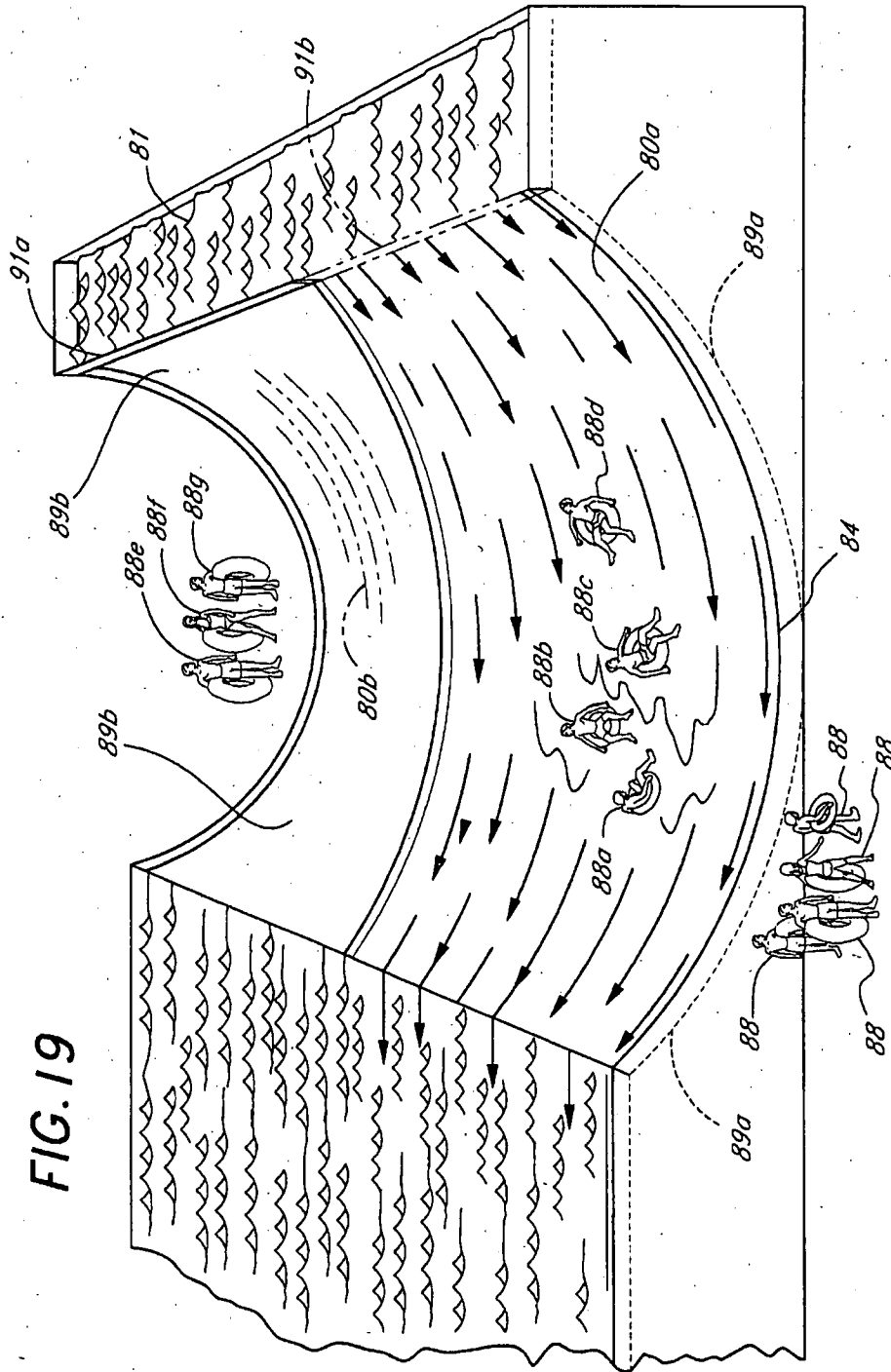

FIG. 19



U.S. Patent

Oct. 15, 1996

Sheet 19 of 19

5,564,859

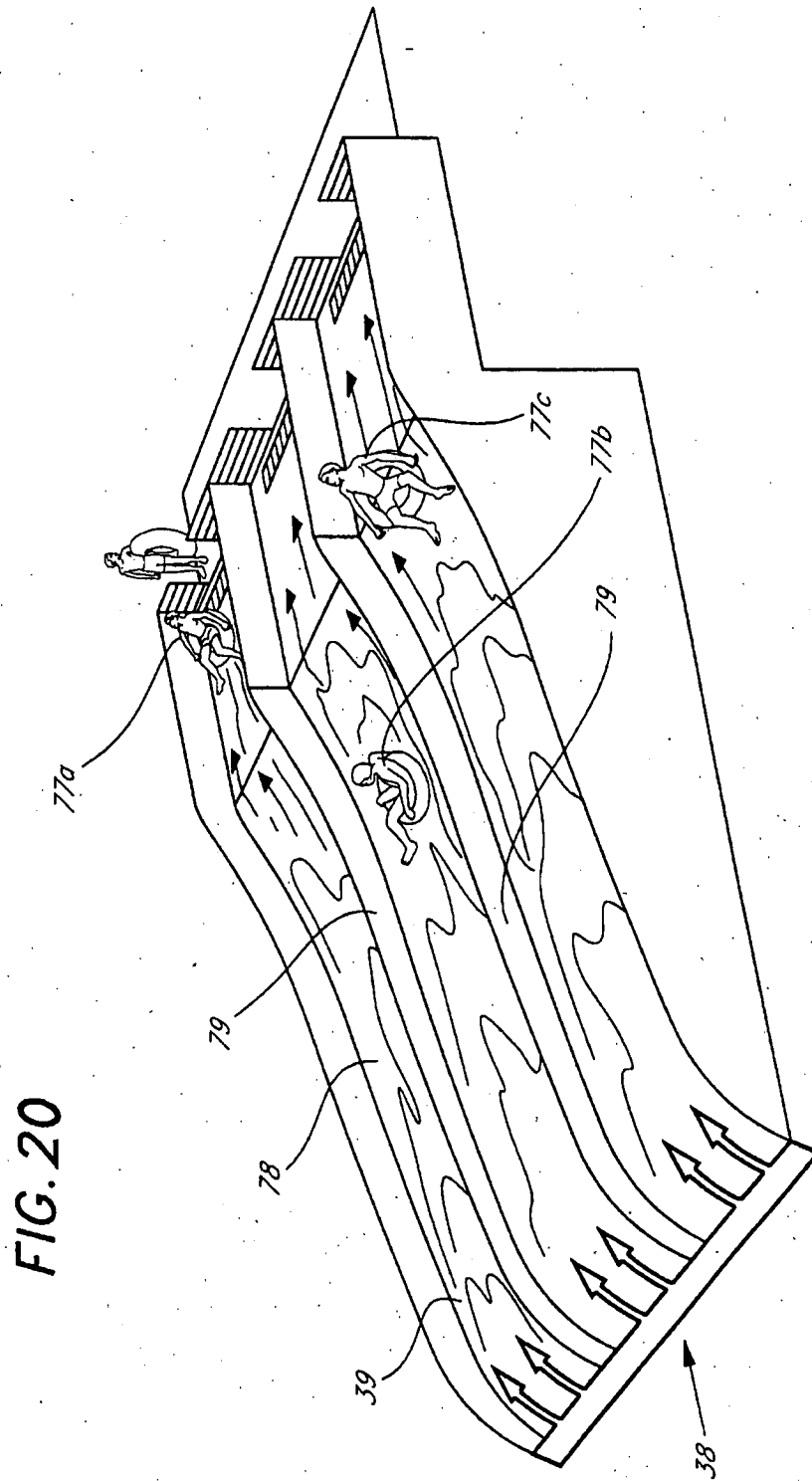

Exhibit 3

5,564,859

1

## METHOD AND APPARATUS FOR IMPROVING SHEET FLOW WATER RIDES

### RELATED APPLICATIONS

This application is a continuation of application Ser. No. 08/074,300, filed Jun. 9, 1993 now as U.S. Pat. No. 5,393,170, which is a continuation of application Ser. No. 577,741, filed Sep. 4, 1990, now U.S. Pat. No. 5,236,280 which is a Continuation-In-Part of U.S. application Ser. No. 07/286,964, filed Dec. 19, 1988 for IMPROVEMENTS IN SURFING-WAVE GENERATORS, issued as U.S. Pat. No. 4,954,014 on Sep. 4, 1990, which is a Continuation-In-Part of U.S. application Ser. No. 07/054,521, filed May 27, 1987 for TUNNEL WAVE GENERATOR, issued as U.S. Pat. No. 4,792,260 on Dec. 20, 1988.

### FIELD OF THE INVENTION

The present invention relates in general to water rides, specifically a mechanism and process that provides a flowing body of water having flat, radial, and inclined surfaces thereon of sufficient area, depth and slope to permit surfboarding, skim-boarding, body-boarding, inner-tubing, and other water-skimming activity and, in particular, to several embodiments with means for generated, forming, maintaining, moving and riding said flow of water in a predominantly steady state condition.

### BACKGROUND OF THE INVENTION

For the past 25 years, surfboard riding and associated wave riding activities, e.g., knee-boarding, body or "Boogie" boarding, skim-boarding, surf-kayaking, inflatable riding, and body surfing (all hereinafter collectively referred to as wave-riding) have continued to grow in popularity along the world's surf endowed coastal shorelines. In concurrence, the 80's decade has witnessed phenomenal growth in the participatory family water recreation facility, i.e., the waterpark. Large pools with manufactured waves have been an integral component in such waterparks. Several classes of wavepools have successfully evolved. The most popular class is that which enables swimmers or inner-tube/inflatable mat riders to bob and float on the undulating swells generated by the wave apparatus. A few pools exist that provide large turbulent white-water bores that surge from deep to shallow pool end. Such pools enable wave-riding. However, white-water bore riding is not preferred by the cognoscenti of the wave-riding world, rather the forward smooth water face of a curling or tubing wave that runs parallel to the shoreline holds the ultimate appeal. Although numerous attempts have been made to establish wave-riding on curling waves as a viable activity in the commercial waterpark wavepool setting, such attempts have met with limited success. The reasons which underlie wave-riding's limited waterpark success is four-fold, 1) small spilling or unbroken waves which are ideal for the mass of novice waterpark attendees are not ideal for intermediate or advanced wave-riders; 2) the larger waves ideal for wave riding have proven prohibitive in cost to duplicate and become inherently more dangerous as their size increases; 3) the curling and plunging waves sought by advanced wave riders require steep and irregular pool bottom configurations that are inherently dangerous and can cause strong deep water current; 4) assuming a compromised and safer wave shape is acceptable to wave-riding participants, wave-riding is ideally a one-man-to-one-wave event that monopolizes an extended surface area. As a consequence of limited wave quality, ex-

2

sive cost, potential liability, and large surface area to low rider capacity ratios, wavepools specifically designed for waveriders have proven unjustifiable to water park operators.

All wavepools that currently exist in the waterpark industry and the majority of previously disclosed wave-making inventions attempt to duplicate those types of oscillatory waves found naturally occurring at a beach. For purposes of definition, such waves are hereinafter termed "natural waves". Natural waves also include those found occurring in rivers as caused by submerged obstacles e.g., boulders. As known to those skilled in the art, natural waves have specific characteristics capable of mathematical description as a function of wave length, wave height, period, wave angle, velocity, phase speed, break speed, gravity, free surface water elevation, water depth, etc. Additionally, mathematical descriptions can be provided for a wide range of wave shapes progressing from an unbroken-to-breaking-to broken. Breaking waves, those of most interest to wave-riders, are traditionally classified as either spilling, plunging or surging. Broken waves can either be stationary (e.g., a river impacting on an obstacle creating a stationary hydraulic jump), or moving (e.g., an ocean white water surge or bore characterized by rapidly varied unsteady flow). The shape of a breaking wave is primarily a function of a given set of the aforementioned wave characteristics and the contour of the bottom over which the wave is moving. Beginning wave-riders prefer the smaller gentle spilling wave produced by a gradually sloped bottom surface. Advanced wave-riders prefer the larger plunging breakers that result from a steeply inclined beach. Since there are demographically a greater number of beginning wave-riders and since the wave favored by beginning riders is a product of an inherently safer gentle incline of beach, and since the energy and cost required to produce a small spilling wave is exponentially less than required to produce a large plunging wave, the current genre of wave pools have by necessity and practicality not been suitable for wave-riding by the more advanced wave rider.

The subject invention aims at creating a "wave shape" that can serve to provide those types of "wave shapes" desired by intermediate to advanced riders. Additionally, the subject invention seeks to accomplish such "wave shape" creation at a fraction of the cost and with an improved margin of safety as compared to that required to duplicate the aforementioned intermediate to advanced natural waves. The reason the subject invention can succeed at its goal is that it does not duplicate natural waves, rather, it creates "flow shapes" that are a result of high velocity sheet flow over a suitably shaped forming surface. This concept of sheet flow formation versus natural wave formation is one of two primary distinguishing factors between the subject invention and the prior art.

This second distinguishing factor focuses on the forces that "drive" a wave rider when he is riding a wave. To this end, the subject invention defines two distinct classes of flow shapes, i.e., deep water flow shapes and shallow water flow shapes. A deep water flow shape is where the water depth is sufficient such that boundary layer effects of the sheet flow over the forming surface does not influence the operation of rider or riding vehicle, e.g., surfboard. Deep water flow shapes can, assuming certain flow forming and flow characteristics (e.g., velocity) are met, duplicate naturally occurring waves. A shallow water flow shape is where the water is of such depth that the surface boundary layer effects of the sheet flow over the forming surface influences the operation of rider or riding vehicle, e.g., surfboard. As contemplated

5,564,859

3

by the subject invention, shallow water flow shapes will never duplicate naturally occurring waves, because there are differing forces that come into play when a rider rides a shallow flow. As the result of those differing forces, the operational dynamics of the subject invention require that for shallow flows the average velocity of the water sheeting over the flow forming surface will always exceed the maximum velocity which would be found in a natural wave. To better explain why the shallow water flow velocity must always be greater than that of a deep water flow, and to further expand on the forces involved when a surfer rides an ocean wave or conversely when a "skimmer" rides a shallow water flow, the following examples are given: On a natural wave (a deep water flow environment) a surfer prior to starting a ride begins to move up the slope of the coming wave by primarily the forces of buoyancy. In order to overcome the forces of fluid drag, the surfer commences to paddle and take advantage of the interaction between the forces of buoyancy and gravity to provide a forward component to the surfboard and achieve riding speed. Thereafter, maintenance of a steady state position riding normal to the wave front is a balancing act between on the one hand, the hydrodynamic lift forces on the bottom of the surfboard coupled with buoyancy, and on the other hand, the forces of gravity and fluid drag. Cutting/trimming across the wave front (at an angle to the wave front) requires the same balancing act. If one attempts to reproduce the above described scenario in natural flow conditions, a large water depth is required. Likewise, in the laboratory setting this can be accomplished by deep water flows (reference the Killen papers, *infra*).

Conversely, in a shallow water flow environment, the forward force component of the "skimmer" and skimming device required to maintain a riding position and overcome fluid drag is due to the downslope component of the gravity force created by the constraint of the solid flow forming surface, balanced primarily by momentum transfer from the high velocity upward shooting flow. The "skimmer's" motion upslope (in excess of the kinetic energy of the "skimmer") consists of the force of the upward shooting flow exceeding the downslope component of gravity. In both deep water and shallow water flow environments, non-equilibrium riding maneuvers such as cross-slope motion and oscillating between different elevations are made possible by the interaction between the respective forces as described above and the use of the rider's kinetic energy.

The parent inventions to the subject applications have focused upon deepwater flow shapes specific to the performance of "surfing maneuvers". Surfing maneuvers, is defined by those skilled in the art, as those which occur under ocean like hydrodynamic conditions. Consequently, surfing maneuvers can be performed in an artificial environment, e.g., a wavepool, assuming that the wave which is produced duplicates the ocean wave riding experience (deep water flow) as described above. By corollary, true surfing maneuvers cannot be performed in shallow flow environments since the hydrodynamic conditions are distinct. However, full scale tests have demonstrated that the physical look and feel of "surfing like maneuvers" performed in a shallow flow are surprisingly similar to "real" surfing maneuvers performed in a deep flow. For purposes of technical clarity, shallow flow "surfing type maneuvers" shall be termed as a subset of what hereafter can be described as "water skimming maneuvers". Water skimming maneuvers are defined as those activities which can be performed on shallow water flows including "surfing like maneuvers" as well as other activities or other types of maneuvers with differing types of vehicles e.g. inner-tubes, bodyboards, etc.

4

The subject invention discloses improvements to the prior art of shallow water flows, as well as similar improvements to the deep water flow shapes of the parent invention. The parent invention generated two types of stationary flow shapes, i.e., a stationary peeling tunnel flow shape for advanced waveriders, and a stationary non-breaking upwardly inclined flow shape for beginners.

#### DISCUSSION OF PRIOR ART

The water recreation field is replete with inventions that generate waves yet lacking as to inventions that create flow formed wave-like shapes. In all cases, none to date describe the improvements contemplated by the subject invention, as an examination of some representative references will reveal.

To facilitate distinction, the prior art can be divided into seven broad wave or wave shape forming categories:

Category 1—an oscillating back-and-forth or periodic up-and-down movement by an object or pressure source that results in disturbance propagation from point to point over a free water surface. Representative prior art: Fisch U.S. Pat. No. 1,655,498; Fisch U.S. Pat. No. 1,701,842; Keller U.S. Pat. No. 1,871,215; Matrai U.S. Pat. No. 3,005,207; Anderson U.S. Pat. No. 3,477,233; Presnell et al U.S. Pat. No. 3,478,444; Kosier U.S. Pat. No. 3,562,823; Anderson U.S. Pat. No. 4,201,496; and Baker U.S. Pat. No. 4,276,664. The structure and operation of Category 1 prior art illustrate those types of devices which generate waves in an unsteady flow, i.e., a wave profile which will vary over distance and time.

Category 2—a moving hydraulic jump caused by the release of a quantity of water. Representative prior art: Dexter U.S. Pat. No. 3,473,334; Bastenhof U.S. Pat. No. 4,522,535; and Schuster, et al U.S. Pat. No. 4,538,719. Although differing in method, the structure and operation of Category 2 prior art is similar to Category 1 in that they generate waves in an unsteady flow, i.e., a wave profile which will vary over distance and time. As to the issues of water depth, direction of flow and direction of wave spill, the channel or pool bottoms of Category 2 devices constantly change in depth and become more shallow as one moves in the direction of the traveling wave and released water.

Category 3—a stationary hydraulic jump resulting in a spilling wave. Representative prior art: Le Mehaute U.S. Pat. No. 3,802,697.

Category 4—a moving hydraulic jump caused by a moving hull. Representative prior art: Le Mehaute '697 (*supra*) also disclosed movement by a wedge shaped body through a non-moving or counter-moving body of water, with such movement causing a hydraulic jump and resultant spilling wave suitable for surf-riding.

Category 5—a wave shape that simulates a stationary unbroken wave. Representative prior art: Frenzl U.S. Pat. No. 3,598,402 issued Aug. 10, 1971 is perhaps more closely related in structure to the shallow water flow embodiments of the present invention than any of the previously discussed references. Frenzl disclosed an appliance for practicing aquatic sports such as surf-riding, water-skiing and swimming comprised of a vat, the bottom of which is upwardly sloping and has a longitudinal section which shows a concavity facing upwards while a stream of water is caused to flow upslope over said bottom as produced by a nozzle discharging water unto the surface of the lower end of said bottom. Provision is made for adjustment of the slope of the vat bottom around a pivotal horizontal axis to permit the

5,564,859

5

appliance to be adjusted for that sport which has been selected for practice, e.g., water skiing reduced slope or surf-riding increased slope. Provision is also made for varying the speed of the water from a "torrential flow" for water skimming activities, e.g., surfboard riding, to a "river type flow" wherein the speed of the water is matched to the speed of an exercising swimmer. However, Frenzl '402 does not recognize, either explicitly or implicitly some of the problems solved and advantages proffered by the present invention.

Frenzl U.S. Pat. No. 4,564,190 issued Jan. 14, 1986 shows improvements to the appliance for practicing aquatic sports using gliding devices (as disclosed in the Frenzl '402 patent) by introduction of a device that removes water from an upwardly sloping bottom surface which has been slowed down by friction at the boundary faces and returns the water to a pumping system to thereby increase the flow rate and thus eliminate the delirious effects of slowed down water. Frenzl U.S. Pat. No. 4,905,987 issued Mar. 6, 1990 shows improvements to the appliance disclosed in the Frenzl '402 patent (described above) by showing connected areas for swimming, non-swimming and a whirlpool so that water from the Frenzl '402 appliance is further utilized after outflow thereof. The primary objective of the Frenzl '987 patent is to improve the start and exit characteristics of the Frenzl '402 appliance by providing a means whereby a user can enter, ride, and exit the appliance to avoid breakdown of the torrential flow.

Category 6—a defective wave shape that simulates a stationary tunnel wave. Representative prior art: Hornung, H. G. and Killen, P., "A Stationary Oblique Breaking wave for Laboratory Testing of Surfboards", *Journal of Fluid Mechanics* (1976), Vol. 78, Part 3, pages 459-484. P. D. Killen, "Model Studies of a Wave Riding Facility", 7th Australasian Hydraulics and Fluid Mechanics Conference, Brisbane, (1980). P. D. Killen and R. J. Stalker, "A facility for Wave Riding Research", Eighth Australasian Fluid Mechanics Conference, University of Newcastle, N.S.W. (1983). The apparatus taught by Killen (all three articles will be collectively referred to as Killen, and each article is specifically referenced by chronological date of publication) forms a wave shape of the type favored by surfboard riders, by placing a suitably shaped fixed position obstacle in a channel of specified width and in the path of a flow of water with specified depth and velocity such that deflection of the water off the obstacle duplicates the geometric and hydrodynamic aspects of a surface gravity wave that is obliquely incident to a sloping beach. At first glance, it may appear that structure as taught by Killen and that as disclosed by the subject invention are substantially similar. However, close examination will reveal significant differences.

In summary, Killen was attempting to create a wave shape that was geometrically and hydrodynamically similar to the ideal wave in the real surfing situation. The "conforming wave shape" as formed by the shallow water flows of the subject invention does not attempt to geometrically and hydrodynamically simulate the ideal wave in the real surfing situation. The "conforming" deep water flows of the subject invention do not require such simulation, even though they can so simulate.

#### SUMMARY OF INVENTION

To better understand the objects and advantages of the invention as described herein, a list of special terms as used herein are defined:

6

- (1) "deep water flow": that flow whereby the water depth is sufficient such that boundary layer effects of the sheet flow over the forming surface does not significantly influence the operation of rider or riding vehicle, e.g., surfboard. Deep water flow shapes can, assuming certain flow forming and flow characteristics (e.g., velocity) are met, duplicate naturally occurring waves.
- (2) "shallow water flow": that flow whereby the water is of such depth that the surface boundary layer effects of the sheet flow over the forming surface significantly influences the operation of rider or riding vehicle, e.g., surfboard. Shallow water flow shapes will never duplicate naturally occurring waves.
- (3) "surfing maneuvers": those maneuvers capable of performance on a surfboard which occur under ocean like hydrodynamic conditions, including deep water flows with the appropriate ocean approximating flow characteristics. Surfing maneuvers include riding across the face of the surface of water on a surfboard, moving down the surface toward the lower end thereof, manipulating the surfboard to cut into the surface of water so as to carve an upwardly arcing turn, riding back up along the face of the inclined surface of the body of water and cutting-back so as to return down and across the face of the body of water and the like, e.g., lip bashing, floaters, inverters, aerials, 360's, etc.
- (4) "water skimming maneuvers": those maneuvers which can be performed on shallow water flows including "surfing like maneuvers" (i.e., similar to those described in "surfing" maneuvers above) as well as, other activities or other types of maneuvers with differing types of vehicles e.g., inner-tubes, bodyboards, etc.
- (5) "body of water": a volume of water wherein the flow of water comprising that body is constantly changing, and with a shape thereof at least of a length, breadth and depth sufficient to permit surfing or water skimming maneuvers thereon as limited or expanded by the respective type of flow, i.e., deep water or shallow water.
- (6) "conform (conformed, conforming)": where the angle of incidence of the entire depth range of a body of water is (at a particular point relative to the inclined flow forming surface over which it flows) predominantly tangential to said surface. Consequently, water which flows upon an inclined surface can conform to gradual changes in inclination, e.g., curves, without causing the flow to deflect. As a consequence of flow conformity, the downstream termination of an inclined surface will always physically direct and point the flow in a direction aligned with the downstream termination surface. A conformed water flow is a non-separated water flow and a deflected water flow is a separated water flow, as the terms separated and non-separated are known by those skilled in the art.
- (7) "equilibrium zone": that portion of an upwardly inclined body of water wherein a rider is in equilibrium depending on the one hand, on an upwardly directed force ascribable to the drag or resistance of the riders vehicle or body dipped into the stream of water and, on the other hand, on a downwardly directed force produced by the component of the weight of the rider in a direction parallel with the inclined water forming means.
- (8) "supra-equidyne area": that portion of a body of water above the equilibrium zone wherein the slope of the

5,564,859

7

incline is sufficiently steep to enable a rider to overcome the upwardly sheeting water flow and slide downwardly thereupon.

(9) "sub-equidyne area": that portion of a body of water below the equilibrium zone that is predominantly horizontal. In the sub-equidyne area a rider cannot achieve equilibrium and will eventually (due to the forces of fluid drag) be moved back up the incline.

One object of the present invention is to improve upon the parent invention by providing a flow forming surface upon which a shallow water flow can produce a body of water that is similar to the kind prized by surfers, i.e., a tunnel wave, which has a mouth and an enclosed tunnel extending for some distance into the interior of the forward face of the wave-shape. Such improvement is hereinafter referred to as the "Shallow Flow Tunnel Wave Generator." Heretofore, tunnel waves have only been available to surfers in a natural or deep water flow environment. The subject invention, through proper configuration of a flow forming surface and adequate shallow water flow characteristics (e.g., velocity, turbidity, depth, direction, etc.), can produce wave forms that have similar appearance and ride characteristics as "real" tunnel waves subject to certain ride conditions, e.g., limitation on surfboard fin size. However, the significant cost savings attributable to shallow flow construction and reduced energy consumption outweigh any limitations that may be imposed.

The parent invention also provided for a stationary non-breaking upwardly inclined deep water flow shape for beginners. The subject invention will also improve upon this embodiment of the parent invention through the use of shallow water flow technology. Such improvement is hereinafter referred to as the "Shallow Flow Inclined Surface." In addition to the significant advantage or reduced cost, additional advantages to the shallow water improvements described above include, increased safety due to reduced deep water pool depth, reductions in water maintenance due to decrease in volume of water treated, and the opportunities to create novel water sports, e.g., flowboarding or inner-tube "bumper cars".

A second object of the subject invention is to provide a flow forming means (hereinafter referred to as the "Connected Structure") comprised of a substantially horizontal flat surface (the sub-equidyne area) that transitions by way of a radial concave arc (the equilibrium zone) connected to the supra-equidyne area (e.g., the inclined plane or tunnel wave generator). The Connected Structure facilitates a riders ability to maximize his forward speed by the riders own efforts of "pump-turning", hereinafter more fully described as the "Acceleration Process". Without benefit of said Connected Structure such increased speed would not be available. The Connected Structure encompasses the complete spectrum of surface flows and wave shapes desired by wave-riding and water skimming enthusiasts. Beginning at one extreme with a flat incline, and progressing by introduction of an increasing array of surface curvatures from the horizontal to the vertical combined with varying attitude and inclination of said surface relative to an upward (or downward, as the case may be) flow of water that culminates at the other extreme in a tunnel wave shape. A significant feature of the Connected Structure is how its unique configuration can dramatically improve the performance parameters of the parent invention's inclined Surface embodiment. The parent invention hereto permitted conventional surfing maneuvers; however, its structure did not optimally facilitate the generation of forward speed with which to perform such maneuvers. The "Acceleration Process" as now enabled by

8

the Connected Structure improvement allows such forward speed to be attained.

A third object of the subject invention is to solve the transient surge problems associated with the ride start-up and rider induced flow decay upon upwardly inclined flow surfaces. This solution results by lowering the downstream boundary area of the inclined flow forming surface at an angle so as to create a maximum height ridge line of decreasing elevation to facilitate self-clearing of undesirable transitory surges. This improvement is hereinafter referred to as the "Self-Clearing Incline."

A fourth object of the subject invention and a novel ramification to the "Self-Clearing Incline" occurs by extending the inclined flow forming surface and associated ridge line of the downstream boundary area to an increased elevation. If such increase in elevation is in excess of the net total head flow necessary to scale this new increase in elevation, then the flow will form a hydraulic jump and the sub-critical water thereof will spill down the upwardly sheeting flow in the manner of a spilling wave. This improvement is hereinafter called the "Inclined Riding Surface with Spilling Wave". The spilling wave phenomena can also be incorporated into the other embodiments as described herein. A corollary improvement to any spilling wave application is a properly configured vent system to handle the water which spills back down the flow forming surface. If such water remained unvented, it would eventually choke the entire flow. Consequently, to maintain a steady state condition, to the extent that new water flows into the system, then, an equal amount of old water must vent out.

A fifth object of the subject invention is to improve by way of combination the tunnel and inclined flow forming surfaces, as well as, creation of an intermediate "spilling wave" that works in combination with the inclined flow surface. This embodiment is hereinafter referred to as the "Omni-Wave". A feature of the Omni-Wave embodiment is its unique flow forming shape can permit (by way of a progressive increase of the net head of the sheet flow) the transformation of a sheet of water flow from a stationary "spilling wave" along the entire forming means, to a transitional "spilling wave" with inclined surface flow, to the final inclined surface flow and tunnel wave shape. This method is hereinafter referred to as the "Wave Transformation Process". The Omni-Wave and the Wave Transformation Process will offer an improved environment for the performance of surfing and water skimming maneuvers.

A sixth object of the present invention is to provide an apparatus that will enable riders to perform surfing and water skimming maneuvers in a format heretofore unavailable except by analogy to participants in the separate and distinct sports of skateboarding and snowboarding, to wit, half-pipe riding. In this regard, the present invention comprises a method and apparatus for forming a body of water with a stable shape and an inclined surface thereon substantially in the configuration of a longitudinally oriented half-pipe. Such improvement is hereinafter referred to as the "Fluid Half-Pipe." A corollary improvement to the Fluid Half-Pipe is to provide an apparatus that permits an increased throughput capacity by increasing the depth of the Fluid Half-Pipe in the direction of its length. This increase in depth will have the added benefit of causing a rider to move in the direction of fall and facilitate his course through the ride.

The final object of the present invention is the positioning of dividers within a Fluid Half-Pipe or Inclined Surface as described above and to prevent a "jet wash" phenomenon

5,564,859

9

that can result in loss of a rider's flow. This "jet wash" phenomenon occurs when a rider who is positioned in the equilibrium or supra-equidyne area of a thin sheet flow gets his flow of water cut off by a second rider positioned with priority to the line of flow. The cutting off of water occurs in thin sheet flow situations due to the squeegee effect caused by the second rider's skimming vehicle. The improvement aids in preventing adjacent riders from cutting off their respective flows of water. Such improvement is hereinafter referred to as "Sheet Flow Dividers."

Other objectives and goals will be apparent from the following description taken in conjunction with the drawings included herewith.

#### BRIEF DESCRIPTION OF THE DRAWINGS

FIG. 1 is a profile view of a Tunnel "Wave" Generator configured for shallow waterflows.

FIG. 2 is a contour map of Tunnel "Wave" Generator as set forth in FIG. 1.

FIG. 3 is a plan view of the range of horizontal attitude with respect to the direction of water flow that the wave generator (as set forth in FIG. 1) can take and still form a tunnel wave.

FIG. 4 is a view in profile of a typical cross-section disclosing the range of inclination of the forward face of the wave generator (as set forth in FIG. 1) with respect to the direction of water and orientation to the vertical.

FIG. 5 depicts a rider on the Tunnel Wave Generator.

FIG. 6 is a profile view of the inclined surface.

FIG. 7 is a cross-sectional view of the inclined surface as shown in FIG. 6.

FIG. 8 depicts a rider on the Inclined Surface.

FIG. 9a is a profile view of the Connected Structure.

FIG. 9b is a cross-section of FIG. 9a.

FIG. 10 depicts a surfer riding an Inclined Surface as improved by the Connected Structure and who is taking advantage of the acceleration process.

FIG. 11a is a profile view of the Self Clearing Incline.

FIG. 11b is a cross-section of FIG. 11a.

FIG. 12 is a contour map of the Self-Clearing Tunnel Wave.

FIG. 13a, FIG. 13b, and FIG. 13c are three views in profile that illustrate in time lapse sequence a self-clearing Inclined Surface.

FIG. 14a and FIG. 14b illustrate in time lapse sequence the self-clearing Tunnel Wave.

FIG. 15 is a profile view of the Omni-Wave.

FIG. 16a depicts the Omni-Wave with a spilling wave formed along its entire front face.

FIG. 16b depicts the Omni-Wave with a clear inclined surface and a spilling wave.

FIG. 16c depicts the Omni-Wave with a clear inclined surface and a Tunnel Wave.

FIG. 16d depicts a Body Boarder performing water skimming maneuvers and a surfer performing surfing maneuvers on the Omni-Wave.

FIG. 16e depicts a knee boarder riding the spilling wave.

FIG. 16f depicts a water skier on the inclined surface and an inner-tube rider on the spilling wave.

FIG. 17 shows in profile view of a novel embodiment for water sports—the Fluid Half-Pipe.

10

FIG. 18a shows an elevation of a typical Fluid Half-Pipe.

FIG. 18b shows an elevation of a Fluid Half-Pipe with modified flow forming bottom to assist in capacity and rider through put.

FIG. 19 illustrates in profile view an improvement to the Fluid Half-Pipe to assist in increased through put capacity.

FIG. 20 shows dividers in a shallow flow to avoid flow "jet wash."

#### DETAILED DESCRIPTION OF THE SUBJECT INVENTION

Because the original application, the continuation of the original application and the subject invention are operated in water, and many of the results of its passage there-through, or the propelling of water against the wave or flow forming means thereof, are similar to those caused by a boat hull, some of the terms used in the descriptions hereto will be nautical or marine terms; likewise, from the perspective of physical water dynamics, some of the terms used herein will be hydraulic engineering terms; and finally, from the perspective of ride operation and function, some of the terms used herein will be terms as used in the sport of surfing; all such terms constitute a ready-made and appropriate vocabulary which is generally understood by those skilled in the art. To the extent that there are special terms, then, those terms are further defined herein.

Further, it will be understood by those skilled in the art that much of the description of structure and function of the wave generator and inclined surface of the original application and its continuation application may apply to the embodiments of the subject invention, to the extent used by this application. Therefore, the descriptions of the flow forming means/wave generator hull and inclined surface of the prior applications should also be read in conjunction with FIGS. 1-20. However, to the extent there are any differences or discrepancies between the description and teaching of the prior applications and the subject invention, the description and teaching of the subject invention shall prevail.

Except where specifically limited, it is to be understood that the embodiments as described herein are to function in both deep and shallow flow environments. Furthermore, that the flow (except where noted) is to be super-critical (i.e., according to the formula  $v > \sqrt{gd}$  where  $v$  = velocity,  $g$  = acceleration due to gravity ft/sec<sup>2</sup>,  $d$  = depth of the sheeting body of water).

#### Description of Shallow Flow Tunnel "Wave" Generator

Turning now to FIG. 1 (isometric view) and FIG. 2 (contour map) there is illustrated a Tunnel "Wave" Generator 30 similar to the generator of prior application, however, improved to serve in a shallow water flow. Plan-sectional lines as revealed in FIG. 1 and contour lines as revealed in FIG. 2 are solely for the purpose of indicating the three-dimensional shape in general, rather than being illustrative of specific frame, plan, and profile sections. Tunnel Generator 30 is comprised of a stem 31, a front face 32, a stern arch 33, an upstream edge 34 running from stem 31 to stern arch 33 and acting as the upstream perimeter of front surface 32, a downstream edge 35 running from stem 31 to stern arch 33 and acting as the downstream perimeter of front face 32, back surface 36, and sub-surface structural support 37. Front surface 32, bounded by upstream edge 34, downstream edge 35 and stern arch 33 is that feature of Tunnel Generator 30 which effectively shapes its tunnel "wave." Moving in a direction as indicated by arrow 38, super-

5,564,859

11

critical shallow water flow 39 originating from a water source (not shown) moves in a conforming flow upward over the front face 32 to form an inclined body of water in the shape of a tunnel "wave" (not shown) upon which a rider (not shown) can ride. Back surface 36 is sufficiently smooth and with transitions analogous to a conventional waterslide such that a rider (not shown) could safely be swept over or around Tunnel Generator 30 to a termination pool or area (not shown) to properly exit. The outside dimensions of the flow forming front face 32 of Tunnel Generator 30 are capable of a broad range of values which depend more upon external constraints, e.g., financial resource, availability of water flow, etc., rather than specific restrictions on the structure itself. However, for purposes of scale and not limitation, in order to form a tunnel "wave" of adequate size to fully accommodate an adult user, the outside dimensions of Tunnel Generator 30 should be approximately 1 to 3 meters in height and 3 to 12 meters in length.

At least three characteristics of front face 32 of Tunnel Generator 30 influence the size, shape and angle of the tunnel "wave," and each of them interacts with the others:

- A. its shape (FIG. 1 and 2);
- B. its attitude—its horizontal position or angle with respect to the direction of water flow (FIG. 3); and
- C. its inclination—its vertical position or angle with respect to the direction of water flow (FIG. 4). Each characteristic of front face 32 is now discussed in detail.

#### A. Shape

Front face 32 of Tunnel Generator 30 has a complex shape comprised of concave curvature, both vertically and horizontally, as indicated generally by the FIG. 1 plan sections lines and FIG. 2 contour lines. Such lines are substantially but not specifically illustrative of the range of possible shapes, as will now be explained more fully:

##### 1. Vertically:

- a. the shape of the vertical curvature can be:
  - (1) substantially a simple arc of a circle; or
  - (2) preferably an arc of a more complex changing curve, e.g.:
    - (a) ellipse;
    - (b) parabola;
    - (c) hyperbola; or
    - (d) spiral.

If a changing curve, it preferably changes from an opening curve (i.e., the ascending water encounters an increasing radius as it ascends front face 32) at stem 31 through a transition point 40; to a closing curve (i.e., the ascending water encounters a decreasing radius as it ascends front face 32) from transition point 40 to stern arch 33. A critical feature of Tunnel Generator 30 is that commencing at transition point 40, front face 32 begins to curve past the vertical. Curvature past the vertical from transition point 40 towards the stern arch 33 gradually increases from 0 to a maximum of 30 degrees: 10 degrees if preferred.

##### 2. Horizontally

- a. The shape of the horizontal curvature can be:
  - (1) substantially an arc of a circle; or
  - (2) preferably, a portion of a more complex, changing, curve, e.g.:
    - (a) ellipse;
    - (b) parabola;
    - (c) hyperbola; or
    - (d) spiral.

#### B. Attitude

As disclosed in FIG. 3, the horizontal attitude of front face 32 with respect to direction 38 of water flow can vary only

12

within certain limits otherwise the "tunnel" will not develop. Since front face 32 has concave curvature of varying degrees along its horizontal axis, for purposes of orientation an extension of upstream edge 34 is used to indicate varying horizontal attitudes of front face 32 therefrom. Accordingly, upstream edge 34 can vary from substantially perpendicular to the direction 38 of water flow to an angle of approximately 35 degrees, as shown.

#### C. Inclination

As disclosed in FIG. 4, the inclination of the front face 32 with respect to the direction 38 of water flow is also limited, otherwise the tunnel will not be developed. Two factors are important with respect to inclination, first, the change in angle of incline relative to the depth of the water must be sufficiently gradual to avoid separation of flow lines/deflection. Second, the angle of release (as defined by a line-tangent to front face 32 at downstream edge 35 when compared to the vertical) must be past the vertical as shown. Amounts past vertical may vary, however, a preferred amount is 10 degrees.

At least two other factors effect the size and shape of tunnel wave formation, i.e., flow velocity and water flow depth. The velocity of the water over Tunnel Generator 30 has a wide range, dependent upon the overall size of the Tunnel Wave Surface and the depth of water. In general, the flow is to be super-critical (i.e., according to the formula  $v > \sqrt{gd}$  where  $v$ =velocity,  $g$ =acceleration due to gravity  $f/sec^2$ ,  $d$ =depth of the sheeting body of water). However, velocities in excess of that which is at a minimum necessary to achieve supercritical velocity are sometimes desired, e.g., to provide sufficient momentum transfer to support the weight component of a given rider, and to achieve the vertical heights required to form a tunnel "wave."

The depth of the water is primarily a function of the minimum necessary to permit a tunnel "wave" to form at a given height, and simultaneously enable the flow of water to support (via momentum transfer) the weight component of a contemplated range of users. Because of the operational requirements of momentum transfer, the depth of the water has direct relationship to the velocity of the water, i.e., the higher the velocity of flow, the lower the requisite depth. Since this embodiment is limited to shallow flows, the depth of water will range from approximately 2 to 40 centimeters.

Tunnel Generator 30 can be fabricated of any of several of well known materials which are appropriate for the use intended. Concrete; formed metal, wood, or fiberglass; reinforced tension fabric; air, foam or water filled plastic or fabric bladders; or any such materials which will stand the structural loads involved. A preferred embodiment includes a thick foamed plastic covering to provide additional protection for the riders using the facility.

Theoretically, no pool or water containment means is required for Tunnel Generator 30, in that the flow from a suitable flow source (e.g., pump and nozzle, fast moving stream or elevated reservoir/lake) is all that is required. However, where water recycling is preferred, then, low channel walls can be constructed to retain the flowing water with a lower collection pool, recycling pump and appropriate conduit connected back to the upstream flow source. The area of channel containment need be only large enough to allow the performance of appropriate water skimming maneuvers, since the curling water of the tunnel wave would remain more or less stationary with respect to the containment structure. Thus, such a structure could be constructed even in a backyard.

From the description above, a number of advantages of Tunnel "Wave" Generator 30 becomes evident:

5,564,859

13

- (a) The energy required to produce a tunnel "wave" shape under shallow flow conditions is dramatically less than that required under "natural" conditions, e.g., as indicated in Killen's 1980 article, the power required to produce operational natural waves is proportional to the height of the wave raised to the 3.5 power ( $hw^{3.5}$ ). Consequently, a 2 meter wave would require 11.3 times the power of a 1 meter wave or approximately 3.7 mega watts or 4800 horsepower. An 8 cm in depth shallow flow wave as contemplated by the subject invention with similar width to Killen's structure would be able to produce a 2 meter high tunnel "wave" for under 400 horsepower.
- (b) The capital costs and operating costs for shallow water tunnel "wave" generation is substantially less than deep water installations.
- (c) The sight, sound, and sensation of tunnel "wave" riding is a thrilling participant and observer experience, that has heretofore only been available to relatively few people in the world. The subject invention will enable this experience to become more readily available.
- (d) From a safety perspective, shallow water is generally perceived as safer in view of drowning.

#### Operation of the Tunnel "Wave" Generator

FIG. 5 illustrates Tunnel Generator 30 in operation with the concavity of front face 32 acting to shape a water walled tunnel from super-critical shallow water flow 39 within and upon which rider 41 can ride. Water flow 39 originating from a water source (not shown) moves in a direction 38 as indicated. At stem 31 water flow 39 moves over front face 32 and onto back surface (not shown). Back surface (not shown) is sufficiently smooth and with transitions analogous to a conventional waterslide such that rider 41 could safely be swept over or around Tunnel Generator 30 to a termination pool or area (not shown) to properly exit. Progressing from transition point 40 to stem arch 33 the horizontal and vertical concavity of front face 32 acts as a scoop to channel and lift water into the central portion of front face 32 towards stem arch 33. Combined with the attitude of Tunnel Generator 30 relative to the direction 38 of water flow 39, the resultant forces thereto propel water flow 39 along the path of least resistance which is upward and outward creating the desired tunnel 42. Tunnel 42 size is adjustable depending upon the velocity of water flow 39, i.e., the higher the flow velocity the larger the tunnel effect. The forward force component required to maintain rider 41 (including any skimming device that he may be riding) in a stable riding position and overcome fluid drag is due to the downslope component of the gravity force created by the constraint of the solid flow forming surface balanced primarily by momentum transfer from the high velocity upward shooting water flow 39. Rider's 41 motion upslope (in excess of the kinetic energy of rider 41) consists of the force of the upward shooting water flow 39 exceeding the downslope component of gravity. Non-equilibrium riding maneuvers such as cross-slope motion and oscillating between different elevations on the "wave" surface are made possible by the interaction between the respective forces as described above and the use of the rider's kinetic energy.

Accordingly, it should now be apparent that Tunnel "Wave" Generator 30 embodiment of this invention can use shallow water flow in a water ride attraction to simulate ocean tunnel waves. In addition, Tunnel "Wave" Generator 30 has the following advantages:

- it requires a fraction of the energy utilized in generating a "real" wave;
- it costs substantially less to build and maintain;

14

it allows a rider to experience the sight, sound, and sensation of tunnel wave riding, an experience that heretofore has not been available in commercial settings;

it uses shallow water which is inherently safer than deep water in the prevention of drowning.

#### Description of Shallow Flow Inclined Surface

Turning now to FIG. 6, there is illustrated shallow flow inclined surface 44. Plan-sectional lines as revealed in FIG. 6 are solely for the purpose of indicating the three-dimensional shape in general, rather than being illustrative of specific frame, plan, and profile sections. Shallow flow inclined surface 44 is comprised of sub-surface structural support 45; back surface 46; and front face 47 which is bounded by an imaginary downstream ridge line 48, an upstream edge 49, and side edge 50a and 50b. Side edge 50 can have walls (not shown) or be connected with conventional broad surfaced downhill sliding transitions (not shown) to either contain or allow a rider to move out and off of the flow. Front face 47 can either be a gradual sloping inclined plane, a continuous concave planar surface, a concave planar surface joined to a convex planar surface, or preferably a combination of planar curved surfaces and planar inclined surfaces. FIG. 7 shows in cross-section a preferred profile of front face 47 with upstream edge 49 (indicated as a point in this cross-sectional view) as the upstream boundary and with a combination of curves and straight inclines as follows: concave curvature 51 as one moves upwards towards the downstream ridge 48 (indicated as a point in this cross-sectional view); concave curvature 51 transitioning to a straight incline 52 at a concave/straight transition point 53; straight incline 52 continuing to straight/convex transition point 55; and convex curvature 56 from straight/convex transition point 55 to downstream ridge 48. Back surface 46 joins front face 47 at the downstream ridge line 48. Back surface 46 is sufficiently smooth and with transitions analogous to a conventional waterslide such that a rider (not shown) could safely be swept over downstream ridge line 48 to a termination pool or area (not shown) to properly exit. Turning back to FIG. 6, super critical water flow 39 originating from a water source (not shown) moves in direction 38 to produce a conforming upward flow over front face 47, the downstream ridge line 48 and onto the back surface 46 to form an inclined body of water upon which a rider (not shown) can ride. The outside dimensions of the flow forming front face 47 of shallow flow inclined surface 44 are capable of a broad range of values which depend more upon external constraints, e.g., financial resource, availability of water flow, etc., rather than specific restrictions on the structure itself.

The velocity of the water over shallow flow inclined surface 44 has a wide range, dependent upon the overall size of the inclined surface and the depth of water. In general, the flow is to be super-critical (i.e., according to the formula  $v > \sqrt{gd}$  where  $v$ =velocity,  $g$ =acceleration due to gravity  $ft/sec^2$ ,  $d$ =depth of the sheeting body of water). However, velocities in excess of that which is at a minimum necessary to achieve super-critical velocity are sometimes desired, e.g., to provide sufficient momentum transfer to support the weight component of a given rider, and to achieve the vertical heights required to form an unbroken "wave."

The depth of the water is primarily a function of that which is necessary to successfully operate for the purposes intended. Because of the operational requirements of momentum transfer, the depth of the water has direct relationship to the velocity of the water, i.e., the higher the velocity of flow, the lower the requisite depth. Since this



5,564,859

15

embodiment is limited to shallow flows, the depth of water will range from approximately 2 to 40 centimeters.

Shallow flow inclined surface 44 can be fabricated of any of several of well known materials which are appropriate for the use intended. Concrete; formed metal, wood or fiber-glass; reinforced tension fabric; air, foam or water filled plastic or fabric bladders; or any such materials which will stand the structural loads involved. A preferred embodiment includes a thick foamed plastic covering to provide additional protection for the riders using the facility.

Theoretically, no pool or water containment means is required for shallow flow inclined surface 44, in that the flow from a suitable flow source (e.g., pump and nozzle, fast moving stream or elevated reservoir/lake) is all that is required. However, where water recycling is preferred, then, low channel walls can be constructed to retain the flowing water with a lower collection pool, recycling pump and appropriate conduit connected back to the upstream flow source. The area of channel containment need be only large enough to allow the performance of appropriate water skimming maneuvers. Thus, such a structure could be constructed even in a back yard.

From the description above, a number of advantages of Shallow Flow Inclined Surface 44 becomes evident:

- (a) The energy required to produce an unbroken "wave" shape similar to that simulated by Shallow Flow Inclined Surface 44 is dramatically less than that required under "natural" conditions, e.g., as indicated in Killen's 1980 article, the power required to produce operational natural waves is proportional to the height of the wave raised to the 3.5 power ( $hw^{3.5}$ ). Consequently, a 2 meter wave would require 11.3 times the power of a 1 meter wave or approximately 3.7 mega watts or 4800 horsepower. An 8 cm in depth shallow flow wave as contemplated by the subject invention with similar width to Killen's structure would be able to produce a 2 meter high inclined surface "wave" for under 400 horsepower.
- (b) The capital costs and operating costs for shallow water inclined surface "wave" generation is substantially less than deep water installations.
- (c) The sight, sound, and sensation of inclined surface "wave" riding is a thrilling participant and observer experience, that has heretofore only been available to relatively few people in the world. The subject invention will enable this experience to be become more readily available.
- (d) From a safety perspective, shallow water is generally perceived as safer in view of drowning.

#### Operation of Shallow Flow Inclined Surface

FIG. 8 illustrates Shallow Flow Inclined Surface 44 in operation. Super-critical water flow 39 originating from a water source (not shown) moves in direction 38 to produce a conforming upward flow over front face 47, the downstream ridge line 48 and onto the back surface 46 to form an inclined body of water upon which rider 41 can ride. Front face 47 serves as the primary riding area for rider 41. On this area rider 41 will be able to perform skimming maneuvers as follows: The forward force component required to maintain rider 41 (including any skimming device that he may be riding) in a stable riding position and overcome fluid drag is due to the downslope component of the gravity force (created by the constraint of sub-surface structural support 45) balanced primarily by momentum transfer from the high velocity upward shooting water flow 39. The motion of rider 41 in an upslope direction (in excess of the kinetic energy of rider 41) consists of the force of the upward shooting water

16

flow 39 exceeding the down slope component of gravity. Non-equilibrium riding maneuvers such as cross-slope motion and oscillating between different elevations on the "wave" surface are made possible by the interaction between the respective forces as described above and the use of rider's 41 kinetic energy. Back surface 46 is sufficiently smooth and with transitions analogous to a conventional waterslide such that rider 41 could safely be swept over downstream ridge line 48 to a termination pool or area (not shown) to properly exit.

Accordingly, it should now be apparent that Shallow Flow Inclined Surface 44 embodiment of this invention can use shallow water flow in a water ride attraction to simulate unbroken ocean waves. In addition, Shallow Flow Inclined Surface 44 has the following advantages:

- it requires a fraction of the energy utilized in generating a "real" wave;
- it costs substantially less to build and maintain;
- it allows a rider to experience the sight, sound, and sensation of continuous unbroken wave riding, an experience that heretofore has not been available in commercial settings. Such capability will greatly expand the training of beginning "surf-riders" and provide a venue for surf-camps, etc.
- it uses shallow water which is inherently safer than deep water in the prevention of drownings.

#### Description of Connected Structure

The Connected Structure creates additional surface area beyond the areas defined by Tunnel Wave Generator 30 and Shallow Flow Inclined Surface 44. In general terms, this expanded area can be described as a horizontal area upstream of the upstream edge of each respective embodiment. Furthermore, the Connected Structure describes specific ratios between three distinct regions that can be defined to exist on Tunnel Wave Generator 30 and Shallow Flow Inclined Surface 44 as improved by the Connected Structure. Through combination of area expansion and defined region size relationship, a flow forming means can be described with performance characteristics as yet undisclosed by the prior art.

Turning now to FIG. 9a, we see a generalized diagram of an improvement for a flow forming means herein called Connected Structure 57. Plan-sectional lines as revealed in FIG. 9a are solely for the purpose of indicating the three-dimensional shape in general, rather than being illustrative of specific frame, plan, and profile sections. Connected Structure 57 is comprised of a supra-equidync area 58 which transitions (as represented by a dashed line 59) to an equilibrium zone 60, which in turn transitions (as represented by a dotted line 61) to a sub-equidync area 62. The dimensions and relationship of Connected Structure's 57 sub-equidync 62, equilibrium 60, and supra-equidync 58 areas are described as follows:

FIG. 9b illustrates a cross-section of Connected Structure 57, with sub-equidync area 62, equilibrium zone 60, and supra-equidync area 58 with a range of configurations 58a, 58b, and 58c that are capable of producing a flow that ranges from the previously described unbroken "wave" (i.e., inclined flow) and the tunnel "wave" flow.

The preferred embodiment for the breadth of the sub-equidync area 62 in the direction of flow 38 is, at a minimum, one and one half to four times the vertical height (as measured from sub-equidync to the top of supra-equidync) of the total flow forming means. The large breadth would apply to low elevation means (e.g., 1 meter) and

5,564,859

17

smaller breadth to high elevation means (e.g., 6 meters). Sub-equidyne 62 orientation is substantially horizontal and normal to the force of gravity.

The preferred embodiment for the shape of equilibrium zone 60 can be defined by a portion of a changing curve, e.g., an ellipse; parabola; hyperbola; or spiral. If a changing curve, the configuration of equilibrium zone 60 is substantially arcs of a closing curve (i.e., the ascending water encounters a decreasing radius as it ascends the face of the flow forming means). The radius of said closing curve being at its smallest approximating the radius of supra-equidyne 58 leading edge, and at its longest less than horizontal. For purposes of simplicity and scale (but not by way of limitation) the uphill breadth of equilibrium zone 60 can generally be defined by a distance approximately equal to the length of the rider's flow skimming vehicle, i.e., approximately three to ten feet.

The preferred embodiment for the shape of supra-equidyne area 58 can be defined by a portion of changing curve, e.g., an ellipse; parabola; hyperbola; or spiral. If a changing curve, the configuration of supra-equidyne area 58 is initially arcs of a closing curve (i.e., the ascending water encounters a decreasing radius as it ascends the face of the flow forming means). The radius of said closing curve is at its longest always less than the radius of the longest arc of equilibrium zone 60, and, at its smallest of sufficient size that a rider could still fit inside a resulting "tunnel wave". On the opposite end of the spectrum, said arcs of a closing curve can transition, after a distance at least equal to  $\frac{1}{4}$ 's the length of the riders flow skimming vehicle (approximately two to seven feet), to arcs of an opening curve (i.e., the ascending water encounters an increasing radius as it ascends the face of the flow forming means). The only limitation as to the overall breadth of supra-equidyne area 58 in the direction of flow 38 is the practical limitation of available head of an upwardly sheeting flow.

Super-critical water flow 39 originating from a water source (not shown) moves in direction 38 to produce a conforming flow over sub-equidyne area 62, equilibrium zone 60, and supra-equidyne area 58 to form an inclined body of water upon which a rider (not shown) can ride and perform surfing or water skimming maneuvers that would not be available but for such Connected Structure 57.

#### Operation of the Connected Structure

The significance of Connected Structure 57 is a function of how it can be used to enable the performance of surfing and water skimming maneuvers. Essential to the performance of modern surfing and skimming maneuvers are the elements of oscillation, speed, and proper area proportion in the "wave" surface that one rides upon. Each element is elaborated as follows:

**OSCILLATION:** The heart and soul of modern surfing is the opportunity for the rider to enjoy substantial oscillation between the supra-critical and sub-critical areas. As one gains expertise, the area of equilibrium is only perceived as a transition area that one necessarily passes through in route to supra and sub critical areas. Oscillatory motion has the added advantage of allowing a rider to increase his speed.

**SPEED:** Speed is an essential ingredient to accomplish modern surf maneuvers. Without sufficient speed, one cannot "launch" into a maneuver. The method and means for increasing one's speed on a properly shaped wave face can be made clear by analogy to the increase of speed on a playground swing as examined in SCIENTIFIC AMERICAN, Mar. 1989, p. 106-109. On a swing, if one is crouching at the highest point of a swing to the rear, ones energy can be characterized as entirely potential energy. As one

18

descends, the energy is gradually transformed into kinetic energy and one gains speed. When one reaches the lowest point, one's energy is entirely kinetic energy and one is moving at peak speed. As one begins to ascend on the arc, the transformation is reversed: one slows down and then stops momentarily at the top of the arc. Whether one goes higher (and faster) during the course of a swing depends on what one has done during such swing. If one continues to crouch, the upward motion is a mirror image of the downward motion, and ones center of mass ends up just as high as when one began the forward swing. If instead one stands when one is at the lowest point, i.e., "pumping" the swing, then one would swing higher and faster.

The importance of sub-equidyne area 62 in the context of the previous discussion of swing dynamics, is that sub-equidyne area 62 is by its nature the lowest point on Connected Structure 57 and on a wave. Standing/extending at this low point results in a larger increase of speed than if one stood at any other point on Connected Surface 57 or on a wave. This increase in speed and total kinetic energy is due to two different mechanistic principals, both of which may be utilized by a rider on Connected Structure 57 or a wave. By standing at the lowest point in the oscillatory path, the center of gravity of the rider is raised allowing a greater vertical excursion up the slope than the original descent. Crouching at the top of the path and alternately standing at the bottom allows an increase in vertical excursion and restoration of energy lost to fluid drag. Additionally, the other mechanism, increasing the kinetic energy, is due to the increase in angular rotation. As the rider in his path rotates around a point located up the wave face, extension/standing at the low point increases his angular velocity much in the same manner as a skater by drawing in his/her arms increases his/her rotational speed due to the conservation of momentum. However, kinetic energy increases due to the work of standing against the centrifugal force and because kinetic energy is proportional to the square of angular velocity, this increase in kinetic energy is equivalent to an increase in speed.

**PROPER AREA PROPORTION:** Connected Structure 57 as a flow forming surface combines in proper proportion the sub-critical 62, equilibrium 60, and supra-critical 58 areas so as to enable a rider to oscillate, attain the requisite speed and have available the requisite transition area for performance of modern day surfing and skimming maneuvers that would not be possible, but for said Connected Structure 57.

Turning to FIG. 10 there is illustrated a surfer 63 on an inclined surface as improved by Connected Structure 57 in various stages of a surfing maneuver. Surfer 63 is in a crouched position on supra-equidyne area 58 and gathering speed as he moves downward over a conformed sheet of super-critical water flow 39 which originates from a water source (not shown) and moves in direction 38. Upon reaching the low point at sub-equidyne area 62, surfer 63 extends his body and simultaneously carves a turn to return to supra-equidyne area 58. As a consequence of such maneuvering, surfer 63 will witness an increase in speed to assist in the performance of additional surfing maneuvers. The process by which a surfing or water skimming rider can actively maneuver to increase his speed is referred to as the Acceleration Process.

#### Description of Self-Clearing Incline and Tunnel Wave

Turning to FIG. 11a (isometric view) and FIG. 11b (cross-sectional view) there is illustrated a top vent self-clearing incline improvement for Shallow Flow Inclined Surface (as improved by Connected Structure) all of which is hereafter referred to as a Self-Clearing Incline 64. Self-

5,564,859

19

Clearing Incline 64 is comprised of Shallow Flow Inclined Surface as modified by lowering the elevation of side edge 50b' and causing downstream ridge line 48 to incline from the horizontal. FIG. 11b superimposes a cross-sectional profile of side edge 50a over the lowered side edge 50b'. To have a noticeable effect, the angle of inclination should be a minimum 5 degrees.

Turning to FIG. 12 (contour map) there is illustrated a swale self-clearing incline improvement for Tunnel "Wave" Generator 30 (as improved by Connected Structure 57) all of which is hereafter referred to as Self-Clearing Tunnel Wave 66, comprised of sculpting from front surface 32, sub-equidynic area 62 and structural matrix support 37 (not shown) a shallow venting swale 65. All surfaces of swale 65 are smooth and without edges.

#### Operation of Self-Clearing Incline and Tunnel Wave

Self-Clearing Incline 64 and Self-Clearing Tunnel Wave 66 are designed to prevent unwanted turbulent white water build-up that fails to clear from the riding surface in the usual manner of "washing" over the downstream ridge of these respective embodiments. In practice, this vent problem will only occur if there is a restriction on flow venting to the side of the inclined surface or generator, e.g., a channel wall, or where there is a tremendous amount of activity, e.g., multiple riders on the surface of the water.

This undesirable build-up is particularly acute in an upward directed flow. This build-up will most likely occur during three stages of operation, (1) water flow start-up with no rider present; (2) transferring the kinetic energy of high speed water flow to a maneuvering rider; and (3) cumulative build-up of water due to a spilling wave. In the start-up situation (1), due to the gradual build up of water flow associated with pump/motor phase in or valve opening, the initial rush is often of less volume, velocity or pressure than that which issues later. Consequently, this initial start water is pushed by the stronger flow, higher pressure, or faster water that issues thereafter. Such pushing results in a build-up of water (a hydraulic jump or transient surge) at the leading edge of the flow. An upward incline of the riding surface serves only to compound the problem, since the greater the transient surge, the greater the energy that is required to continue pushing such surge in an upward fashion. Consequently, the transient surge will continue to build and if unrelieved will result in overall flow velocity decay, i.e., the slowed water causes additional water to pile up and ultimately collapse back onto itself into a turbulent mass of bubbling white water that marks the termination of the predominantly unidirectional super-critical sheet flow. In the situation of kinetic energy transfer (2), when a maneuvering rider encounters faster flowing water or water that is moving in a direction different than the rider, a transient surge builds behind or around the rider. Likewise, if this transient surge grows too large it will choke the flow of higher speed unidirectional super-critical sheet flow, thus, causing flow decay. In the situation of an excessive build up of water over time from a spilling wave (3), the interference of a preceding flow with a subsequent flow can result in an undesired transient surge and flow decay at a point near where the two flows meet. Under all three conditions, it is possible to control or eliminate the transient surge by immediately increasing the flow pressure and over-powering or washing the transient surge off the riding surface. However, there comes a point where the build-up of water volume is so great that for all practical purposes over-powering is either impossible, or at best, a costly solution to a problem capable of less expensive solution. Such less expensive solution is possible by the introduction of vents.

20

Two classes of vent mechanisms are identifiable. The first class, self-clearing inclines, are used to clear transient surges from inclined surfaces. FIG. 13a, 13b, and 13c show in time lapse sequence how the design of self-clearing incline 64 operates to solve the problem of a pressure/flow lag during start-up. In FIG. 13a water flow 39 has commenced issue in an uphill direction from water source (not shown) in direction 38. As water flow 39 moves up front surface 47, the leading edge of water flow is slowed down by a combination of the downward force of gravity and friction with front surface 47, whereupon, it is overtaken and pushed by the faster and stronger flow of water that subsequently issued from the water source. The result of this flow dynamic is that a transient surge 68 begins to build. However, as transient surge 68 builds, it reaches the height of low side edge 50b' and commences to spill over onto back surface 46. FIG. 13b shows this start procedure moments later wherein the water pressure/flow rate from the water source has increased and transient surge 68 has moved further up the incline. FIG. 13c shows the final stage of start-up wherein the transient surge has been pushed over the top of Down Stream Ridge Line 48 and water flow 39 now runs clear. Similar to the start-up procedure, when a lower speed rider encounters the higher speed water, or when an accumulative build-up of water results from a spilling wave, a transient surge may occur. In like manner, the transient surge will clear by spilling off to the lowered side accordingly.

The second class of vent mechanism, swale vents, are used to assist in clearing transient surges from tunnel wave generators. FIG. 14a and 14b show in time lapse sequence how the design of swale 67 operates to solve identical problems as suffered by the inclined surfaces with channel walls. In FIG. 14a water flow 39 has commenced issue in an uphill direction from water source (not shown) in direction 38. Transient surge 68 begins to build. However, as transient surge 68 builds, it commences to vent into swale 67, thus, permitting tunnel wave 42 to properly form as shown in FIG. 14b.

#### Description and Operation of the Omni-Wave

FIG. 15 depicts a preferred embodiment herein named an Omni-wave 69 comprised of Self-Clearing Incline 64 which is interconnected and continuous with Self-Clearing Tunnel Wave 66.

FIG. 16a, FIG. 16b, FIG. 16c, FIG. 16d, FIG. 16e and FIG. 16f illustrates Omni-Wave 69 in operation. A unique feature of Omni-Wave 69 is its unique flow forming shape can permit (by way of a progressive increase of the net head of the water flow) the transformation of super-critical water flow 39 that originates from a water source (not shown) in direction 38 to a stationary spilling wave 70 along the entire forming means (as illustrated in FIG. 16a); to a stationary spilling wave 70 with Self Clearing Incline 64 flow (as illustrated in FIG. 16b); to a Self-Clearing Incline 64 and Self-Clearing Tunnel Wave 66 flow (as illustrated in FIG. 16c). This progressive wave forming method is hereinafter referred to as the "Wave Transformation Process". The Omni-Wave and the Wave Transformation Process will offer an improved environment for the performance of surfing and water skimming maneuvers. FIG. 16d shows surfer 63 and rider 41 on Self-Clearing Tunnel Wave 66 and Self-Clearing Incline 64 respectively. FIG. 16e shows surfer water skimming kneeboarder riding upon stationary spilling wave 70, FIG. 16f shows inner-tube rider 72 and water skier 73 on stationary spilling wave 70 and Self-Clearing Incline 64 respectively.

#### Description and Operation of the Fluid Half Pipe

Turning to FIG. 17 wherein an apparatus is revealed that will enable riders to perform surfing and water skimming

5,564,859

21

maneuvers in a format heretofore unavailable except by analogy to participants in the separate and distinct sports of skateboarding and snowboarding, to wit, half-pipe riding. Fluid Half-Pipe 74, comprises a method and apparatus for generating a body of water 80 with a stable shape and an inclined surface thereon substantially in the configuration of a half-pipe with the opening of said half-pipe facing in an upwards direction. The water 81 which supplies said body of water flows over the leading edge 82 of the half-pipe flow forming means 89 and down one side (hereinafter referred to as the down-flow-side 83), in a direction perpendicular to the length of said half-pipe, across an appropriate sub-equidyne flat section 84, and up and over the other side of the half-pipe (hereinafter referred to as the up-flow-side 85), across the trailing edge 86, and into an appropriate receiving pool 87 or other suitably positioned Fluid Half Pipe or attraction. A rider 88a enters the flow at any appropriate point, e.g., sub-equidyne flat section 84, wherein as a result of his initial forward momentum of entry, the excessive drag of his water-skimming vehicle, and the added drag of the riders weight induced trim adjustments to his riding vehicle, said rider (now 88b) is upwardly carried to a supra-critical area in the upper regions of up-flow-side 85 near the half pipe's trailing edge 86, wherein as a result of the force of gravity in excess of the drag force associated with the riding vehicle and the riders own weight trim adjustments to reduce drag, rider (now 88c) hydro-planes down the up-flow-side 85, across the sub-equidyne flat 84, and performs a turn on down flow side 83 to return to up-flow-side 85 and repeat cycle.

As can be appreciated by those skilled in the art, Fluid Half-Pipe 74 will offer its participants a consistent environment in which to perform known surfing and water skimming maneuvers, and due to the combination of up-side-flow, flat, and down-side-flow a unique environment in which to perform new maneuvers unachievable on existing wave surfaces.

The preferred embodiment for the breadth of the flow forming means 89 of Fluid Half-Pipe 74 approximates Connected Structure 57 joined to its mirror image at the midpoint of sub-equidyne 62. It is preferred that said width remain constant for the length of flow-forming means 89, however, variations in width with resultant variations in cross-sectional shape are possible. The limitations on minimum and maximum width is a function of ones ability to perform surfing and water skimming maneuvers. If the flow forming means is too narrow, a rider would be unable to negotiate the transition from the up-flow side 85 to the down-flow-side 83 or vice versa. If too wide, a rider would not be able to reach or utilize the down-flow side 83 to perform surfing and water skimming maneuvers.

A preferred embodiment for the length of the flow forming means of Fluid Half-Pipe 74 is at a minimum a length sufficiently wide to perform surfing and water skimming maneuvers thereon, and at a maximum a function of desire and/or budget.

A preferred embodiment for the cross-sectional shape of the up-flow side's flow forming means has been shown in FIG. 9b and discussed above. FIG. 9b illustrated a detailed cross-section of Connected Structure 57, with sub-equidyne area 62, equilibrium zone 60, and supra-equidyne area 58. Caution must be taken in the design of the up-flow-side 85 supra-equidyne area to insure proper water flow up and over the trailing edge 86. Excessive steepness or height that results in untimely or improperly located spilling or tunneling waves can result in an excessive build-up of turbulent white water in the sub-equidyne flat area 84 which may culminate in complete deterioration of the up-side-flow.

22

However, since advanced riders, in order to maximize speed and perform certain maneuvers, e.g., aerials, prefer a steep supra-critical area that approaches or exceeds vertical then it is preferred that spilling or tunnel wave formation (if any) be limited to areas adjacent the side openings of half-pipe 74, and that the majority middle half pipe 74 be substantially the shape as illustrated in FIG. 9b with supra-equidyne configuration 58a.

Generally, the elevation of half-pipe-74 leading edge 82 will exceed its line-of-flow position on half-pipe 74 trailing edge 86. This differential in elevation will insure that the water of said body of water 81 will have sufficient dynamic head to overcome all internal and external friction that may be encountered in its circuit down, across, up, and over flow forming means 89. The preferred ratio by which the down-flow-side exceeds the up-flow-side ranges from a minimum of ten to nine to a maximum of ten to one. It is also preferred that the respective leading and trailing edge 82 and 86 remain at constant elevations along the length of the half-pipe. Variations in elevation are possible, however, source pool water 81 dynamics, receiving pool water 87 dynamics, and maintenance of line of flow dynamic head must be accounted for.

In cross-sectional profile, a standard configuration for Fluid Half Pipe 74 is illustrated in FIG. 18a. In this standard configuration the cross-sectional elevation, width, and depth remains constant for the length of half-pipe 74. FIG. 18b illustrates an asymmetrical configuration, wherein, the leading and trailing edges 82 and 86 remain at constant elevations and the width between trailing edges remains constant, however, the distance between trailing edges and the flat sub-equidyne section 84 continues to increase at a constant rate of fall. The object of this particular asymmetrical embodiment is to increase throughput capacity for half-pipe 74 as the result of rider movement in the direction of fall due to the added vector component of gravity force ascribed to the weight of the rider in the direction of fall.

The preferred velocity of water in the subject invention is substantially a function of the overall drop in distance from leading edge 82 to the flat area 84. Consequently, previously discussed preferences in the overall height of the Connected Structure dictate the preferred water velocity. Such velocity can be calculated in accordance with Bernoulli's equation  $v = \sqrt{2gz}$  where  $v$  is the velocity in feet per second,  $g$  is gravity  $\text{ft}/\text{sec}^2$  and  $z$  = vertical distance dropped in feet.

The preferred depth of water is that which is required to perform surfing and water skimming maneuvers. For purposes of Half Pipe 74 the minimum depth is 2 cm. and the maximum depth is whatever one might be able to afford to pump. Except the desirable spilling/tunnel wave formation adjacent a side-opening of half-pipe 74, an additional preference is that the water avoid excessive turbulence that results from a hydraulic jump which occurs when the velocity of a sheeting body of water exceeds a certain critical velocity at a certain minimum depth.

Variations in the breadth and longitudinal movement of the body of water that flows upon the half-pipe can result in enhancements to rider through-put capacity for the Fluid-Half Pipe. FIG. 19 depicts a half-pipe configured flow forming means 89. A stably shaped body of water 80a is situated on one side 89a of said flow forming means. The water 81 which supplies said stably shaped body of water is limited by a dam 91a to just one-half of the flow forming means 89. Riders 88a, b, c and d enter the flow at any appropriate point, e.g., the sub-equidyne flat section 84 and perform water skimming maneuvers thereon. As shown in FIG. 19, the water skimming maneuvers are performed

5,564,859

23

using an inner-tube type vehicle. After an elapsed period of time, e.g., several minutes, a dam 91b is positioned to block the water 81 which supplies the stably shaped body of water 80a on side 89a of said flow forming means. Upon blockage of the source of water, the stably shaped body of water 80a soon ceases to exist on side 89a of said flow forming means. Consequently, the riders 88a, b, c and d drift to the sub-equidync section 84 and can easily exit. Simultaneously with, or shortly after the blockage by dam 91b, dam 91a opens and water 81 begins to flow over flow forming means 89b, whereupon forming a stably shaped body of water 80b that remains situated on side 89b. Riders 88e, f, and g enter the flow and commence to perform water skimming maneuvers for their allotted time span, whereupon dam 91a is re-positioned and the cycle is set to repeat.

FIG. 20 illustrates super-critical water flow 39 originating from a water source (not shown) moving in direction 36 to produce a conforming upward flow over front face 78. Dividers 79 provide separation for the individual riders 77a, 77b, and 77c and to prevent a "jet wash" phenomenon that can result in loss of a rider's flow. This "jet wash" phenomenon occurs when a rider who is positioned in the equilibrium or supra-equidync area of a thin sheet flow gets his flow of water cut off by a second rider positioned with priority to the line of flow. The cutting off of water occurs in thin sheet flow situations due to the squeegee effect caused by the second rider's skimming vehicle.

As will be recognized by those skilled in the art, certain modifications and changes can be made without departing from the spirit or intent of the present invention. For example, the curvatures given as examples for the Connected Structure do not have to be geometrically precise; approximations are sufficient. The same is true of limits in angles, radii and ratios. The temperature and density of the water will have some difference although the range of temperatures in which surfer/riders would be comfortable is fairly limited.

The terms and expressions which have been employed in the foregoing specifications are used therein as terms of description and not of limitation, and there is no intention, in the use of such terms and expressions, of excluding equivalents of the features shown and described, or portions thereof, it being recognized that the scope of the invention is defined and limited only by the claims which follow.

I claim:

1. A water ride apparatus for supporting a shallow flow of water thereon upon which water skimming maneuvers may be performed, said ride apparatus comprising a ride surface having:

a downward curving flow-supporting surface defining a leading edge of said ride surface relative to said shallow flow of water thereon;

an upward curving flow-supporting surface defining a trailing edge of said ride surface relative to said shallow flow of water thereon; and

an intermediate flow-supporting surface contiguous with and curving substantially continuously downward and forward from said downward curving surface and then curving substantially upward and forward toward said upward curving surface;

said ride surface being disposed relative to said shallow flow of water such that said shallow flow of water flows from said leading edge of said ride surface to said trailing edge of said ride surface so as to form a concave riding surface upon which skateboard-like water skimming maneuvers may be performed.

2. The water ride apparatus of claim 1 wherein said ride surface is formed in the shape of a semi-circular tube having

24

concave cylindrical flow-supporting surfaces of substantially uniform curvature.

3. The water ride apparatus of claim 1 wherein said ride surface is formed in the shape of a flattened cylinder wherein said intermediate surface is substantially elongated and less arcuate than said upward and downward curving surfaces,

4. The water ride apparatus of claim 1 wherein said ride surface is formed in an asymmetric configuration wherein the distance between said upward and downward curving surfaces and said intermediate surface varies in a direction transverse to said shallow flow of water.

5. The water ride apparatus of claim 1 wherein said leading edge of said ride surface is at a higher elevation than said trailing edge of said ride surface.

6. The water ride apparatus of claim 1 further comprising one or more dividers disposed tangentially to said shallow flow of water defining a plurality of riding lanes for accommodating multiple ride participants and/or ride vehicles while substantially preventing-upstream ride participants from interrupting water flow to downstream ride participants.

7. The water ride apparatus of claim 1 wherein said ride surface is inclined in a direction transverse to said shallow flow of water so as to facilitate clearing of transient surges of water occurring therein.

8. The water ride apparatus of claim 7 wherein said ride surface is inclined at an angle of at least about five degrees.

9. A multi-participant water ride apparatus for supporting a shallow flow of water thereon upon which ride participants may perform water skimming maneuvers, said water ride apparatus comprising a ride surface having:

a first flow-supporting surface disposed adjacent an upstream portion of said shallow flow of water defining a substantially sub-equidync flow area;

a second flow-supporting surface disposed adjacent a downstream portion of said shallow flow of water defining a substantially supra-equidync flow area; and

a third flow-supporting surface contiguous with and curving substantially continuously from said first flow-supporting surface to said second flow-supporting surface defining an intermediate equilibrium flow area;

one or more dividers disposed tangentially to said shallow flow of water defining a plurality of riding lanes for accommodating multiple ride participants and/or ride vehicles;

whereby multiple ride participants can perform water skimming maneuvers on said shallow flow of water while substantially preventing upstream ride participants from interrupting water flow to downstream ride participants.

10. The water ride apparatus of claim 9 wherein the fluid drag forces on a ride participant and/or ride vehicle riding in said sub-equidync flow area are greater than the gravitational forces exerted on said ride participant and/or ride vehicle in a direction tangential to said shallow flow of water, the fluid drag forces exerted on said ride participant and/or ride vehicle riding in said supra-equidync flow area are lesser than the gravitational forces exerted on said ride participant and/or ride vehicle in a direction tangential to said shallow flow of water, and the fluid drag forces exerted on said ride participant and/or ride vehicle riding in said equilibrium flow area are substantially balanced by the gravitational forces exerted on said ride participant and/or ride vehicle in a direction tangential to said shallow flow of water such that a ride participant by controlling the angle and direction of said ride participant's body and/or ride

5,564,859

25

vehicle with respect to said shallow flow of water can vary the drag forces exerted on said ride participant and/or ride vehicle in order to perform desirable oscillating water skimming maneuvers whereby said ride participant oscillates between said sub-equidyne, equilibrium and supra-equidyne flow areas.

11. The water ride apparatus of claim 9 further comprising a fourth flow-supporting surface disposed downstream of said second surface defining a second sub-equidyne flow area for allowing safe exiting of ride participants.

12. The water ride apparatus of claim 9 further comprising one or more drains disposed downstream of said second surface adapted to collect said shallow flow of water and direct it to a water recirculation system.

13. A water ride apparatus for supporting a shallow flow of water thereon upon which ride participants may perform oscillating water skimming maneuvers, said water ride apparatus comprising a ride surface having:

a first flow-supporting surface defining a substantially sub-equidyne flow area in which the fluid drag forces on a ride participant and/or ride vehicle are greater than the gravitational forces exerted on said ride participant and/or ride vehicle in a direction tangential to said shallow flow of water;

a second flow-supporting surface defining a substantially supra-equidyne flow area in which the fluid drag forces exerted on said ride participant and/or ride vehicle are lesser than the gravitational forces exerted on said ride participant and/or ride vehicle in a direction tangential to said shallow flow of water; and

a third flow-supporting surface between said first flow-supporting surface and said second flow-supporting surface defining an intermediate equilibrium flow area in which the fluid drag forces exerted on said ride participant and/or ride vehicle are substantially balanced by the gravitational forces exerted on said ride participant and/or ride vehicle in a direction tangential to said shallow flow of water;

whereby said ride participant by controlling the angle and direction of said ride participant's body and/or ride vehicle with respect to said shallow flow of water can vary the drag forces exerted on said ride participant and/or ride vehicle in order to perform desirable oscillating water skimming maneuvers whereby said ride participant oscillates between said sub-equidyne, equilibrium and supra-equidyne flow areas.

14. The water ride apparatus of claim 13 wherein said ride surface is formed in the shape of a semi-circular tube having concave cylindrical flow-supporting surfaces of substantially uniform curvature.

15. The water ride apparatus of claim 14 wherein said ride surface is formed in the shape of a complex curve such as an ellipse, parabola, hyperbola and/or spiral.

16. The water ride apparatus of claim 13 wherein said ride surface is formed to simulate the shape of a tunnel wave.

17. The water ride apparatus of claim 14 further comprising a connected ride surface structure comprising a substantially horizontal flat flow-supporting surface defining an extended sub-equidyne flow area for allowing ride participants to increase their speed and/or acceleration by pump turning in said extended sub-equidyne area.

18. The water ride apparatus of claim 13 further comprising one or more dividers disposed tangentially to said shallow flow of water defining a plurality of riding lanes for accommodating multiple ride participants and/or ride vehicles while substantially preventing upstream ride participants from interrupting water flow to downstream ride participants.

26

19. The water ride apparatus of claim 13 wherein said ride surface is inclined in a direction transverse to said shallow flow of water so as to facilitate clearing of transient surges of water occurring therein.

20. The water ride apparatus of claim 13 further comprising a swale vent for allowing substantially continuous venting of run-off water.

21. A wave forming structure adapted to support a shallow flow of water thereon simulating the shape of a tunnel wave and upon which water skimming maneuvers may be performed, said wave forming structure comprising a ride surface having:

a first flow-supporting surface disposed adjacent an upstream portion of said shallow flow of water defining a substantially sub-equidyne flow area;

a second flow-supporting surface disposed adjacent a downstream portion of said shallow flow of water defining a substantially supra-equidyne flow area; and a third flow-supporting surface contiguous with and curving substantially continuously from said first flow-supporting surface to said second flow-supporting surface defining an intermediate equilibrium flow area;

said first, second and third flow-supporting surfaces being inclined in a direction transverse to said shallow flow of water so as to facilitate clearing of transient surges of water occurring therein.

22. The wave forming structure of claim 21 wherein said flow-supporting surfaces are inclined at an angle of at least about five degrees.

23. The wave forming structure of claim 21 further comprising a swale vent for allowing substantially continuous venting of run-off water.

24. The wave forming structure of claim 21 wherein said first surface is formed in the shape of an opening curve having an increasing radius in the direction of said flow of shallow water.

25. The wave forming structure of claim 21 wherein said first surface is formed in the shape of a closing curve having a decreasing radius in the direction of said flow of shallow water.

26. The wave forming structure of claim 21 further comprising one or more dividers disposed tangentially to said shallow flow of water defining a plurality of riding lanes for accommodating multiple ride participants and/or ride vehicles while substantially preventing upstream ride participants from interrupting water flow to downstream ride participants.

27. The wave forming structure of claim 22 further comprising a connected ride surface structure comprising a substantially horizontal flat flow-supporting surface defining an extended sub-equidyne flow area for allowing ride participants to increase their speed and/or acceleration by pump turning in said extended sub-equidyne area.

28. The wave forming structure of claim 21 further comprising a fourth flow-supporting surface disposed downstream of said second surface defining a second sub-equidyne flow area for allowing safe exiting of ride participants.

29. The water ride apparatus of claim 1 wherein said shallow flow of water is of such depth that the surface boundary layer effects of the water flow over the ride surface are more substantial than wave propagation effects of the water flow on the ride surface.

30. The water ride apparatus of claim 1 wherein said shallow flow of water has a thickness of about 2 cm.

31. The water ride apparatus of claim 1 wherein said shallow flow of water has a thickness between about 2 cm and 8 cm.

5,564,859

27

- 32. The water ride apparatus of claim 1 wherein said shallow flow of water has a thickness of about 8 cm or more.
- 33. The water ride apparatus of claim 9 wherein said shallow flow of water is of such depth that the surface boundary layer effects of the water flow over the ride surface are more substantial than wave propagation effects of the water flow on the ride surface. 5
- 34. The water ride apparatus of claim 9 wherein said shallow flow of water has a thickness of about 2 cm.
- 35. The water ride apparatus of claim 9 wherein said shallow flow of water has a thickness of between about 2 cm and 8 cm. 10
- 36. The water ride apparatus of claim 9 wherein said shallow flow of water has a thickness of about 8 cm or more.
- 37. The water ride apparatus of claim 13 wherein said shallow flow of water is of such depth that the surface boundary layer effects of the water flow over the ride surface are more substantial than wave propagation effects of the water flow on the ride surface. 15
- 38. The water ride apparatus of claim 13 wherein said shallow flow of water has a thickness of about 2 cm. 20

28

- 39. The water ride apparatus of claim 13 wherein said shallow flow of water has a thickness of between about 2 cm and 8 cm.
- 40. The water ride apparatus of claim 13 wherein said shallow flow of water has a thickness of about 8 cm or more.
- 41. The wave forming structure of claim 21 wherein said shallow flow of water is of such depth that the surface boundary layer effects of the water flow over the ride surface are more substantial than wave propagation effects of the water flow on the ride surface.
- 42. The wave forming structure of claim 21 wherein said shallow flow of water has a thickness of about 2 cm.
- 43. The water ride apparatus of claim 21 wherein said shallow flow of water has a thickness of between about 2 cm and 8 cm.
- 44. The water ride apparatus of claim 21 wherein said shallow flow of water has a thickness of about 8 cm or more.

\* \* \* \* \*

AO 120 (Rev. 3/04)

TO: <b>Mail Stop 8</b> <b>Director of the U.S. Patent and Trademark Office</b> P.O. Box 1450 Alexandria, VA 22313-1450	<b>REPORT ON THE                  FILING OR DETERMINATION OF AN                  ACTION REGARDING A PATENT OR                  TRADEMARK</b>
---	--

In Compliance with 35 U.S.C. § 290 and/or 15 U.S.C. § 1116 you are hereby advised that a court action has been filed in the U.S. District Court Southern Dist. of CA on the following  Patents or  Trademarks:

DOCKET NO.	DATE FILED	U.S. DISTRICT COURT For the Southern District of CA
PLAINTIFF WAVE LOCH, INC., a California corporation, and LIGHT WAVE, LTD., a Utah Limited partnership		DEFENDANT AMERICAN WAVE MACHINES, INC., a California corporation
PATENT OR TRADEMARK NO.	DATE OF PATENT OR TRADEMARK	HOLDER OF PATENT OR TRADEMARK
1 5,236,280	August 17, 1993	Light Wave, LTD.
2 5,393,170	Feb. 28, 1995	Light Wave, LTD.
3 5,564,859	October 15, 1996	Light Wave, LTD.
4		
5		

ORIGINAL

FAKED

In the above-entitled case, the following patent(s)/trademark(s) have been included:

DATE INCLUDED	INCLUDED BY <input type="checkbox"/> Amendment <input type="checkbox"/> Answer <input type="checkbox"/> Cross Bill <input type="checkbox"/> Other Pleading	
PATENT OR TRADEMARK NO.	DATE OF PATENT OR TRADEMARK	HOLDER OF PATENT OR TRADEMARK
1		
2		
3		
4		
5		

In the above-entitled case, the following decision has been rendered or judgement issued:

DECISION/JUDGEMENT
--------------------

CLERK	(BY) DEPUTY CLERK	DATE
-------	-------------------	------

Copy 1—Upon initiation of action, mail this copy to Director Copy 3—Upon termination of action, mail this copy to Director  
 Copy 2—Upon filing document adding patent(s), mail this copy to Director Copy 4—Case file copy



JS 44  
(Rev. 07/89)

### CIVIL COVER SHEET

The JS-44 civil cover sheet and the information contained herein neither replace nor supplement the filing and service of pleadings of other papers, as required by law, except as provided by local rules of court. This form, approved by the Judicial Conference of the United States in September 1974, is required for the use of the Clerk of Court for the purpose of initiating the civil docket sheet. (SEE INSTRUCTIONS ON THE SECOND PAGE OF THIS FORM.)

**I. (a) PLAINTIFFS**  
WAVE LOCH, INC., a California corporation,  
and LIGHT WAVE, LTD., a Utah Limited  
partnership

**DEFENDANTS**  
AMERICAN WAVE MACHINES, INC.,  
California corporation

08 MAY 23 PM 4:17  
U.S. DISTRICT COURT  
SOUTHERN DISTRICT OF CALIFORNIA

**(b) COUNTY OF RESIDENCE OF FIRST LISTED PLAINTIFF** San Diego  
(EXCEPT IN U.S. PLAINTIFF CASES)

**BY:** [Signature]  
COUNTY OF RESIDENCE OF FIRST LISTED DEFENDANT San Diego  
(IN U.S. PLAINTIFF CASES ONLY) **DEPUTY**

NOTE: IN LAND CONDEMNATION CASES, USE THE LOCATION OF THE TRACT OF LAND INVOLVED.

**(c) ATTORNEYS (FIRM NAME, ADDRESS, AND TELEPHONE NUMBER)**  
Craig S. Summers  
KNOBBE, MARTENS, OLSON, & BEAR, LLP  
2040 Main Street, Fourteenth Floor  
Irvine, CA 92614  
(949) 760-0404

ATTORNEYS (IF KNOWN)  
  
**'08 CV 0928 W WMC**

ORIGINAL

FAXED

**II. BASIS OF JURISDICTION** (PLACE AN 'X' IN ONE BOX ONLY)

- 1 U.S. Government Plaintiff
- 2 U.S. Government Defendant
- 3 Federal Question (U.S. Government Not a Party)
- 4 Diversity (Indicate Citizenship of Parties in Item III)

**III. CITIZENSHIP OF PRINCIPAL PARTIES** (PLACE AN 'X' IN ONE BOX FOR PLAINTIFF AND ONE BOX FOR DEFENDANT)

- |   |                            |                            |   |                            |                            |
|---|----------------------------|----------------------------|---|----------------------------|----------------------------|
|   | <b>PT</b>                  | <b>DEF</b>                 |   | <b>PT</b>                  | <b>DEF</b>                 |
| Citizen of This State                   | <input type="checkbox"/> 1 | <input type="checkbox"/> 1 | Incorporated or Principal Place of Business in This State     | <input type="checkbox"/> 4 | <input type="checkbox"/> 4 |
| Citizen of Another State                | <input type="checkbox"/> 2 | <input type="checkbox"/> 2 | Incorporated and Principal Place of Business in Another State | <input type="checkbox"/> 5 | <input type="checkbox"/> 5 |
| Citizen or Subject of a Foreign Country | <input type="checkbox"/> 3 | <input type="checkbox"/> 3 | Foreign Nation  | <input type="checkbox"/> 6 | <input type="checkbox"/> 6 |

**IV. CAUSE OF ACTION** (CITE THE U.S. CIVIL STATUTE UNDER WHICH YOU ARE FILING AND WRITE A BRIEF STATEMENT OF CAUSE. DO NOT CITE JURISDICTIONAL STATUTES UNLESS DIVERSITY.) 35 U.S.C. Sections 271 and 281. Complaint for patent infringement.

**V. NATURE OF SUIT** (PLACE AN 'X' IN ONE BOX ONLY)

CONTRACT	TORTS	FORFEITURE/PENALTY	BANKRUPTCY	OTHER STATUTES	
<input type="checkbox"/> 110 Insurance <input type="checkbox"/> 120 Marine <input type="checkbox"/> 130 Miller Act <input type="checkbox"/> 140 Negotiable Instrument <input type="checkbox"/> 160 Recovery of Overpayment & Enforcement of Judgment <input type="checkbox"/> 151 Medicare Act <input type="checkbox"/> 152 Recovery of Defaulted Student Loans (Excl. Veterans) <input type="checkbox"/> 163 Recovery of Overpayment of Veteran's Benefits <input type="checkbox"/> 160 Stockholders' Suits <input type="checkbox"/> 190 Other Contract <input type="checkbox"/> 185 Contract Product Liability	<b>PERSONAL INJURY</b> <input type="checkbox"/> 310 Airplane <input type="checkbox"/> 316 Airplane Product Liability <input type="checkbox"/> 320 Assault, Libel & Slander <input type="checkbox"/> 330 Federal Employers' Liability <input type="checkbox"/> 340 Marine <input type="checkbox"/> 346 Marine Product Liability <input type="checkbox"/> 350 Motor Vehicle <input type="checkbox"/> 355 Motor Vehicle Product Liability <input type="checkbox"/> 380 Other Personal Injury	<b>PERSONAL INJURY</b> <input type="checkbox"/> 362 Personal Injury - Medical Malpractice <input type="checkbox"/> 365 Personal Injury - Product Liability <input type="checkbox"/> 368 Asbestos Personal Injury Product Liability	<input type="checkbox"/> 810 Agriculture <input type="checkbox"/> 820 Other Food & Drug <input type="checkbox"/> 825 Drug Related Seizure of Property 21 USC 881 <input type="checkbox"/> 830 Liquor Laws <input type="checkbox"/> 840 R.R. & Truck <input type="checkbox"/> 860 Airline Regs. <input type="checkbox"/> 860 Occupational Safety/Health <input type="checkbox"/> 890 Other	<input type="checkbox"/> 422 Appeal 28 USC 158 <input type="checkbox"/> 423 Withdrawal 28 USC 157 <b>PROPERTY RIGHTS</b> <input type="checkbox"/> 820 Copyrights <input checked="" type="checkbox"/> 830 Patent <input type="checkbox"/> 840 Trademark <b>SOCIAL SECURITY</b> <input type="checkbox"/> 861 HIA (13956) <input type="checkbox"/> 862 Black Lung (823) <input type="checkbox"/> 863 DIWC/DIWW (405(g)) <input type="checkbox"/> 864 SSID Title XV <input type="checkbox"/> 865 RSJ (405(g)) <b>FEDERAL TAX SUITS</b> <input type="checkbox"/> 870 Taxes (U.S. Plaintiff or Defendant) <input type="checkbox"/> 871 IRS - Third Party 26 USC 7609	<input type="checkbox"/> 400 State Reappointment <input type="checkbox"/> 410 Antitrust <input type="checkbox"/> 430 Banks and Banking <input type="checkbox"/> 450 Commercial/CC Rates/etc. <input type="checkbox"/> 480 Deportation <input type="checkbox"/> 470 Racketeer Influenced and Corrupt Organizations <input type="checkbox"/> 610 Selective Service <input type="checkbox"/> 650 Securities/Commodities/Exchange <input type="checkbox"/> 875 Customer Challenge 12 USC 3410 <input type="checkbox"/> 891 Agricultural Acts <input type="checkbox"/> 892 Economic Stabilization Act <input type="checkbox"/> 893 Environmental Matters <input type="checkbox"/> 894 Energy Allocation Act <input type="checkbox"/> 895 Freedom of Information Act <input type="checkbox"/> 900 Appeal of Fee Determination Under Equal Access to Justice <input type="checkbox"/> 950 Constitutionality of State Statutes <input type="checkbox"/> 890 Other Statutory Actions
<b>REAL PROPERTY</b> <input type="checkbox"/> 210 Land Condemnation <input type="checkbox"/> 220 Foreclosure <input type="checkbox"/> 230 Rent Lease & Ejectment <input type="checkbox"/> 240 Torts to Land <input type="checkbox"/> 245 Tort Product Liability <input type="checkbox"/> 290 All Other Real Property	<b>CIVIL RIGHTS</b> <input type="checkbox"/> 441 Voting <input type="checkbox"/> 442 Employment <input type="checkbox"/> 443 Housing/Accommodations <input type="checkbox"/> 444 Welfare <input type="checkbox"/> 440 Other Civil Rights	<b>PRISONER PETITIONS</b> <input type="checkbox"/> 610 Motion to Vacate Sentence <b>HABEAS CORPUS:</b> <input type="checkbox"/> 630 General <input type="checkbox"/> 635 Death Penalty <input type="checkbox"/> 640 Mandamus & Other <input type="checkbox"/> 650 Civil Rights <input type="checkbox"/> 685 Prison Conditions	<input type="checkbox"/> 710 Fair Labor Standards Act <input type="checkbox"/> 720 Labor/Mgmt. Relations <input type="checkbox"/> 730 Labor/Mgmt. Reporting & Disclosure Act <input type="checkbox"/> 740 Railway Labor Act <input type="checkbox"/> 790 Other Labor Litigation <input type="checkbox"/> 791 Empl. Ret. Inc. Security Act		

**VI. ORIGIN** (PLACE AN 'X' IN ONE BOX ONLY)

- 1 Original Proceeding
- 2 Removal from State Court
- 3 Remanded from Appellate Court
- 4 Reinstated or Reopened
- 5 Transferred from another district (specify)
- 6 Multidistrict Litigation
- 7 Appeal to District Judge from Magistrate Judgment

**VII. REQUESTED IN COMPLAINT:**  CHECK IF THIS IS A CLASS ACTION UNDER F.R.C.P. 23 DEMAND \$ accor to proof CHECK YES only if demanded in complaint: JURY DEMAND:  YES  NO

**VIII. RELATED CASE(S) IF ANY** (See instructions): JUDGE \_\_\_\_\_ Docket Number \_\_\_\_\_

DATE 5/23/08 SIGNATURE OF ATTORNEY OF RECORD [Signature]

**INSTRUCTIONS FOR ATTORNEYS COMPLETING CIVIL COVER SHEET FORM JS-44**

Authority For Civil Cover Sheet

The JS-44 civil cover sheet and the information contained herein neither replaces nor supplements the filings and service of pleading or other papers as required by law, except as provided by local rules of court. This form, approved by the Judicial Conference of the United States in September 1974, is required for the use of the Clerk of Court for the purpose of initiating the civil docket sheet. Consequently a civil cover sheet is submitted to the Clerk of Court for each civil complaint filed. The attorney filing a case should complete the form as follows:

I. (a) **Plaintiffs - Defendants.** Enter names (last, first, middle initial) of plaintiff and defendant. If the plaintiff or defendant is a government agency, use only the full name or standard abbreviations. If the plaintiff or defendant is an official within a government agency, identify first the agency and then the official, giving both name and title.

(b) **County of Residence.** For each civil case filed, except U.S. plaintiff cases, enter the name of the county where the first listed plaintiff resides at the time of filing. In U.S. plaintiff cases, enter the name of the county in which the first listed defendant resides at the time of filing. (NOTE: In land condemnation cases, the county of residence of the "defendant" is the location of the tract of land involved.)

(c) **Attorneys.** Enter the firm name, address, telephone number, and attorney of record. If there are several attorneys, list them on an attachment, noting in this section "(see attachment)".

II. **Jurisdiction.** The basis of jurisdiction is set forth under Rule 8(a), F.R.C.P., which requires that jurisdictions be shown in pleadings. Place an "X" in one of the boxes. If there is more than one basis of jurisdiction, precedence is given in the order shown below.

United States plaintiff. (1) Jurisdiction based on 28 U.S.C. 1345 and 1348. Suits by agencies and officers of the United States are included here.

United States defendant. (2) When the plaintiff is suing the United States, its officers or agencies, place an "X" in this box.

Federal question. (3) This refers to suits under 28 U.S.C. 1331, where jurisdiction arises under the Constitution of the United States, an amendment to the Constitution, an act of Congress or a treaty of the United States. In cases where the U.S. is a party, the U.S. plaintiff or defendant code takes precedence, and box 1 or 2 should be marked.

Diversity of citizenship. (4) This refers to suits under 28 U.S.C. 1332, where parties are citizens of different states. When Box 4 is checked, the citizenship of the different parties must be checked. (See Section III below; federal question actions take precedence over diversity cases.)

III. **Residence (citizenship) of Principal Parties.** This section of the JS-44 is to be completed if diversity of citizenship was indicated above. Mark this section for each principal party.

IV. **Cause of Action.** Report the civil statute directly related to the cause of action and give a brief description of the cause.

V. **Nature of Suit.** Place an "X" in the appropriate box. If the nature of suit cannot be determined, be sure the cause of action, in Section IV above, is sufficient to enable the deputy clerk or the statistical clerks in the Administrative Office to determine the nature of suit. If the cause fits more than one nature of suit, select the most definitive.

VI. **Origin.** Place an "X" in one of the seven boxes.

Original Proceedings. (1) Cases which originate in the United States district courts.

Removed from State Court. (2) Proceedings initiated in state courts may be removed to the district courts under Title 28 U.S.C., Section 1441. When the petition for removal is granted, check this box.

Remanded from Appellate Court. (3) Check this box for cases remanded to the district court for further action. Use the date of remand as the filing date.

Reinstated or Reopened. (4) Check this box for cases reinstated or reopened in the district court. Use the reopening date as the filing date.

Transferred from Another District. (5) For cases transferred under Title 28 U.S.C. Section 1404(a). Do not use this for within district transfers or multidistrict litigation transfers.

Multidistrict Litigation. (6) Check this box when a multidistrict case is transferred into the district under authority of Title 28 U.S.C. Section 1407. When this box is checked, do not check (5) above.

Appeal to District Judge from Magistrate Judgment. (7) Check this box for an appeal from a magistrate's decision.

VII. **Requested in Complaint. Class Action.** Place an "X" in this box if you are filing a class action under Rule 23, F.R.Cv.P.

**Demand.** In this space enter the dollar amount (in thousands of dollars) being demanded or indicate other demand such as a preliminary injunction.

**Jury Demand.** Check the appropriate box to indicate whether or not a jury is being demanded.

VIII. **Related Cases.** This section of the JS-44 is used to reference relating pending cases if any. If there are related pending cases, insert the docket numbers and the corresponding judge names for such cases.

**Date and Attorney Signature.** Date and sign the civil cover sheet.

(rev. 07/89)

**UNITED STATES  
DISTRICT COURT**  
SOUTHERN DISTRICT OF CALIFORNIA  
SAN DIEGO DIVISION

**# 151248 - MB**

**May 23, 2008  
16:15:50**

**Civ Fil Non-Pris**

USAO #: 08CV0928 CIVIL FILING

Judge.: THOMAS J WHELAN

Amount.: \$350.00 CK

Check#.: BC69066

**Total-> \$350.00**

**FROM: WAVE LOCH INC VS AMERICAN  
WAVE MACHINES**