

Receipt Number
537758

130
Exh A-E

UNITED STATES DISTRICT COURT
EASTERN DISTRICT OF MICHIGAN
SOUTHERN DIVISION

INTELLECTUAL SCIENCE AND
TECHNOLOGY, INC,

Plaintiff,

vs.

THOMSON, INC.

Defendant.

Case: 2:06-cv-10410
Assigned To : Zatkoff, Lawrence P
Referral Judge: Scheer, Donald A
Assign. Date : 01/30/2006 @ 4:39 P.M.
Description: cmp intellectual
science and technology, inc v.
thomson, inc. (tam)

Joseph C. Basta (P24645)
Thomas M. Schehr (P54391)
Lisa A. Brown (P67208)
DYKEMA GOSSETT PLLC
Attorneys for Plaintiff
400 Renaissance Center
Detroit, Michigan 48243-1668
(313) 568-6800

COMPLAINT FOR PATENT INFRINGEMENT AND JURY DEMAND

Plaintiff Intellectual Science and Technology, Inc., by its attorneys, Dykema Gossett PLLC, for its Complaint For Patent Infringement, states as follows:

1. Plaintiff is a Michigan corporation with its principal place of business in Bloomfield Hills, Michigan.
2. Upon information and belief, Defendant Thomson, Inc. ("Thomson") is a Delaware corporation, having its principal place of business at 10330 North Meridian Street, Indianapolis, Indiana 46206.

3. This action arises under United States patent laws, 35 U. S. C. § 1 *et seq.* The Court has jurisdiction under 28 U. S. C. §§ 1331 and 1338.

4. Venue is proper in this district pursuant to 28 U.S.C. § 1391.

5. Plaintiff is the owner by assignment of U. S. Patent No. 5,748,575, which was duly and legally issued on May 5, 1998 (copy attached as Exhibit A), U.S. Patent No. 6,222,799, which was duly and legally issued on April 24, 2001 (copy attached as Exhibit B), U.S. Patent No. 6,662,239, which was duly and legally issued on December 9, 2003 (copy attached as Exhibit C), U.S. Patent No. 6,717,890, which was duly and legally issued on April 6, 2004 (copy attached as Exhibit D), U.S. Patent No. 6,785,198, which was duly and legally issued on August 31, 2004 (copy attached as Exhibit E) (collectively referred to as "Patents"). The Patents remain valid and enforceable, all required maintenance fees having been paid thereon.

6. Upon information and belief, Thomson manufactures, offers for sale and/or sells devices that infringe the Patents including, but not limited to, RCA CDRW-120 and RCA CDRW-121, that form a material component of the claimed invention of the Patents and are known by Thomson to be especially made or especially adapted for use in infringing the Patents. These machines are not staple articles or commodities of commerce suitable for substantial noninfringing use. Further, Thomson promotes these machines for use in practicing the claimed invention and otherwise actively induces infringement of the Patents.

7. Upon information and belief, Thomson has been, and still is, directly infringing the Patents, contributing to the infringement of the Patents and willfully inducing others to infringe the Patents.

8. Plaintiff has sustained money damages as a result of the conduct of Thomson.

9. Plaintiff has been, and will continue to be, damaged and irreparably harmed by the conduct of Thomson unless it is enjoined by this Court.

Therefore, Plaintiff asks the Court to:

- A. Enjoin Thomson from contributing to or otherwise inducing infringement of Plaintiff's Patents;
- B. Award Plaintiff damages adequate to compensate for the infringement but, in no event less than a reasonable royalty for the use made of the invention by the infringer, together with interest and costs as fixed by the Court pursuant to 35 U. S. C. § 284;
- C. Increase the damages three times for Defendant's willful infringement pursuant to 35 U. S. C. § 284;
- D. Award Plaintiff its reasonable attorneys fees in accordance with 35 U. S. C. § 285;
- E. Award Plaintiff all other relief to which it is entitled.

JURY DEMAND

Plaintiff demands a trial by jury.

DYKEMA GOSSETT PLLC

By: 
Joseph C. Basta (P24645)
Thomas M. Schehr (P54391)
Lisa A. Brown (P67208)
Attorneys for Plaintiff
400 Renaissance Center
Detroit, Michigan 48243-1668
(313) 568-6800

Dated: January 30, 2006

DET01W493491.1
ID\LAKE

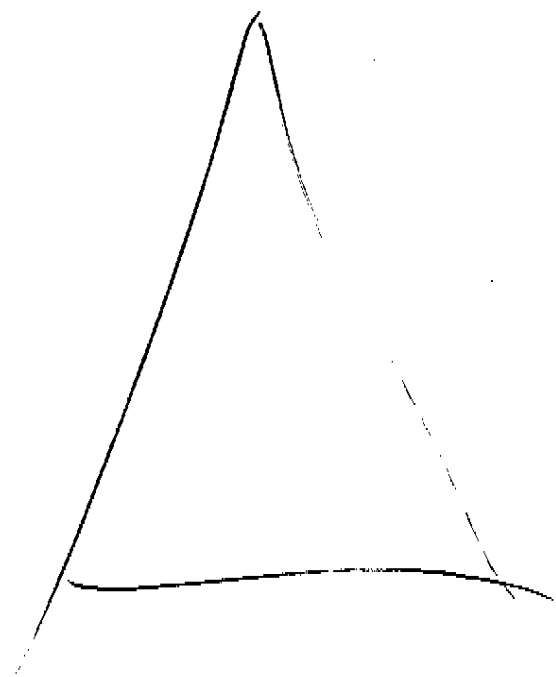



US005748575A

United States Patent [19]

[11] **Patent Number:** 5,748,575

Lee

[45] **Date of Patent:** May 5, 1998

[54] **INFORMATION PROCESSING APPARATUS HAVING A MULTITASKING FUNCTION WITH ONE OR MORE OPTICAL DISCS**

5,146,451	9/1992	Kang	369/178
5,189,652	2/1993	Inoue	369/36
5,193,079	3/1993	Ko et al.	369/37
5,251,192	10/1993	Liu	369/36
5,253,235	10/1993	Isobe et al.	369/37
5,335,218	8/1994	Osada	369/178
5,375,113	12/1994	Pollard et al.	369/30
5,495,457	2/1996	Takagi	369/30
5,615,345	3/1997	Wangter	369/30 X

[75] **Inventor:** Howard Hong-Dough Lee, Bloomfield, Mich.

[73] **Assignee:** Intellectual Science and Technology, Inc., Bloomfield, Mich.

[21] **Appl. No.:** 613,806

[22] **Filed:** Mar. 5, 1996

[51] **Int. Cl.⁶** G11B 17/22

[52] **U.S. Cl.** 369/30; 369/36

[58] **Field of Search** 369/30, 34, 36, 369/38, 192, 178, 39, 32, 37, 35, 183, 197; 360/98.01, 98.04, 98.05, 98.06

[56] **References Cited**

U.S. PATENT DOCUMENTS

4,644,515	2/1987	Allebest et al.	369/32
4,722,078	1/1988	Nakanishi et al.	369/39
4,888,751	12/1989	Yoshimaru et al.	369/36
5,043,963	8/1991	Iwamoto	369/36
5,119,354	6/1992	Umesaki	369/36

Primary Examiner—Ali Neyzaci

Attorney, Agent, or Firm—Hartman & Hartman, P.C.

[57] **ABSTRACT**

A high-performance optical information processing apparatus having various hardware for arriving at multitasking function. The optical information processing apparatus provides disc-loading and -unloading flexibility, allows a user to launch a software program or simultaneously several software programs directly from an optical disc and/or several optical discs stored therein, eliminates tedious and time-consuming software installation, affords a kind of copyright protection to software, and alleviates the burden of accessing a hard-disk drive during the process of information reproduction.

15 Claims, 15 Drawing Sheets

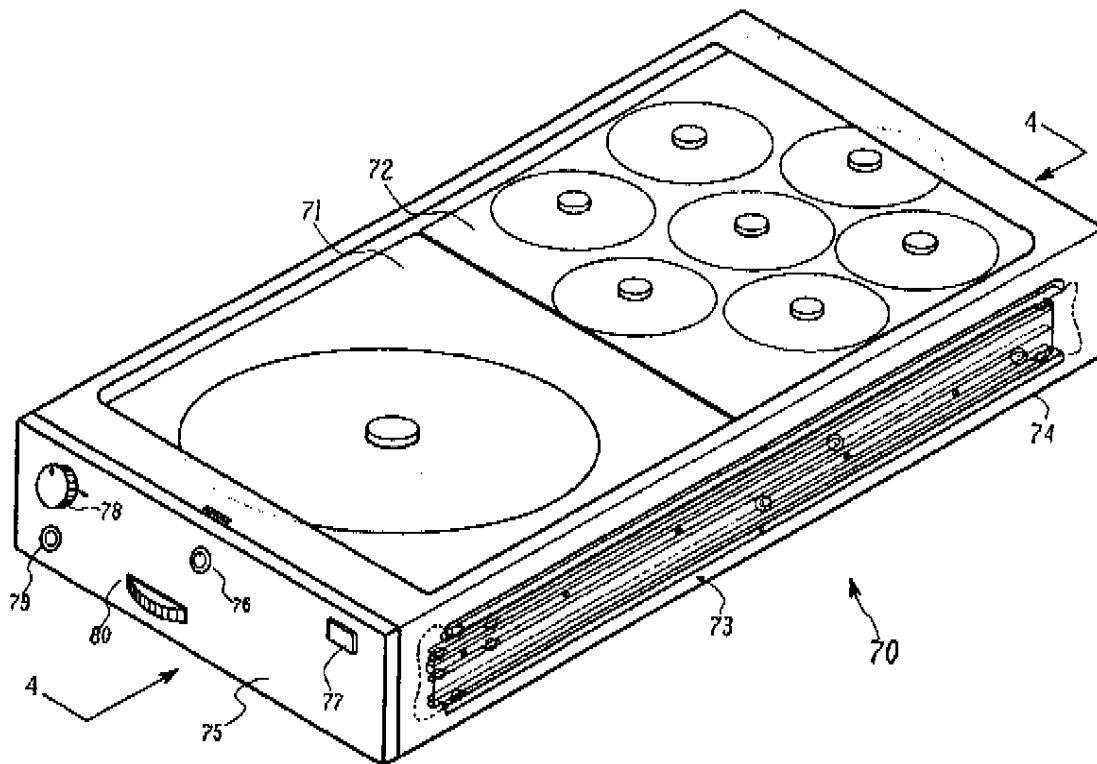

U.S. Patent

May 5, 1998

Sheet 1 of 15

5,748,575

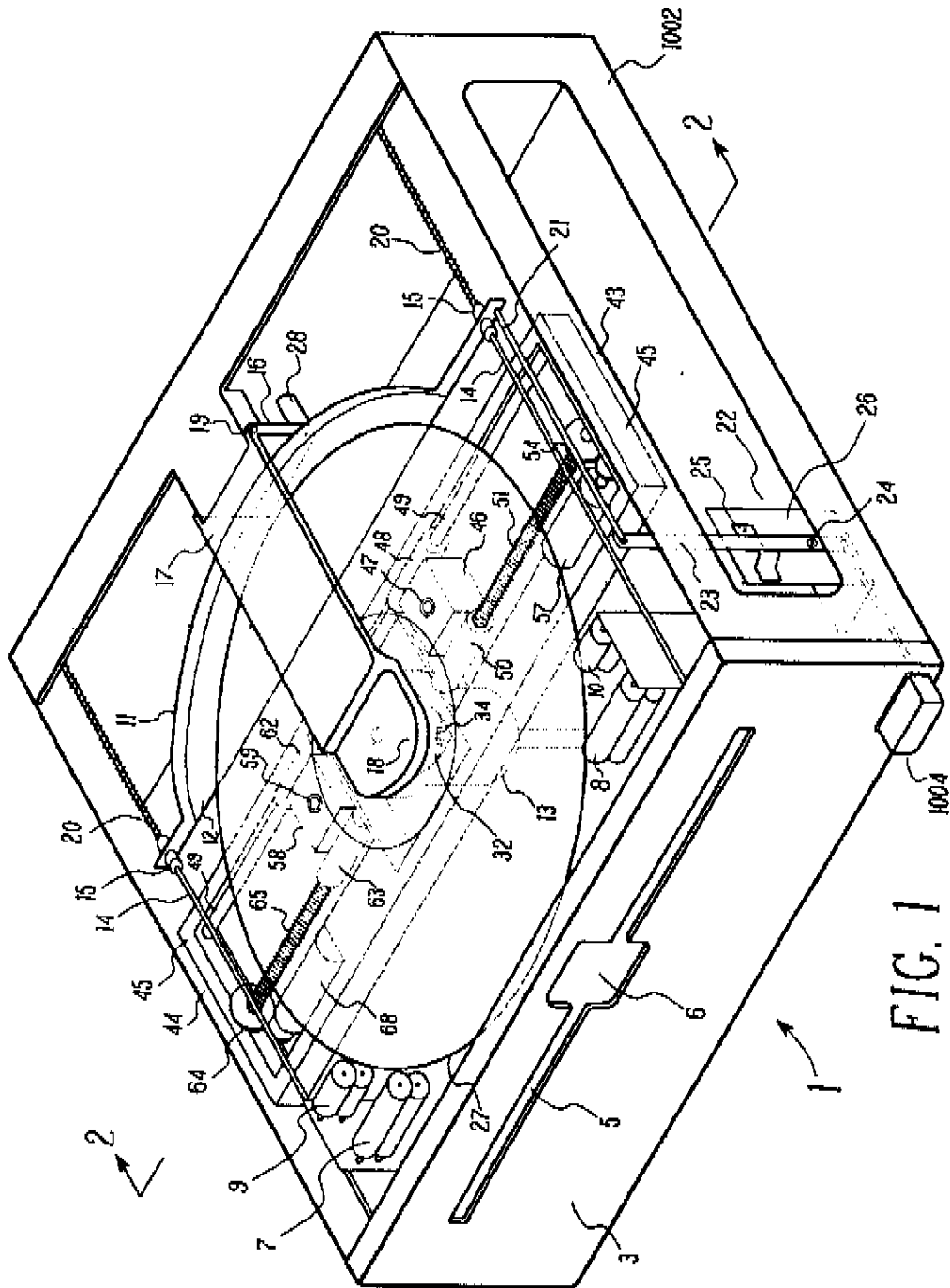

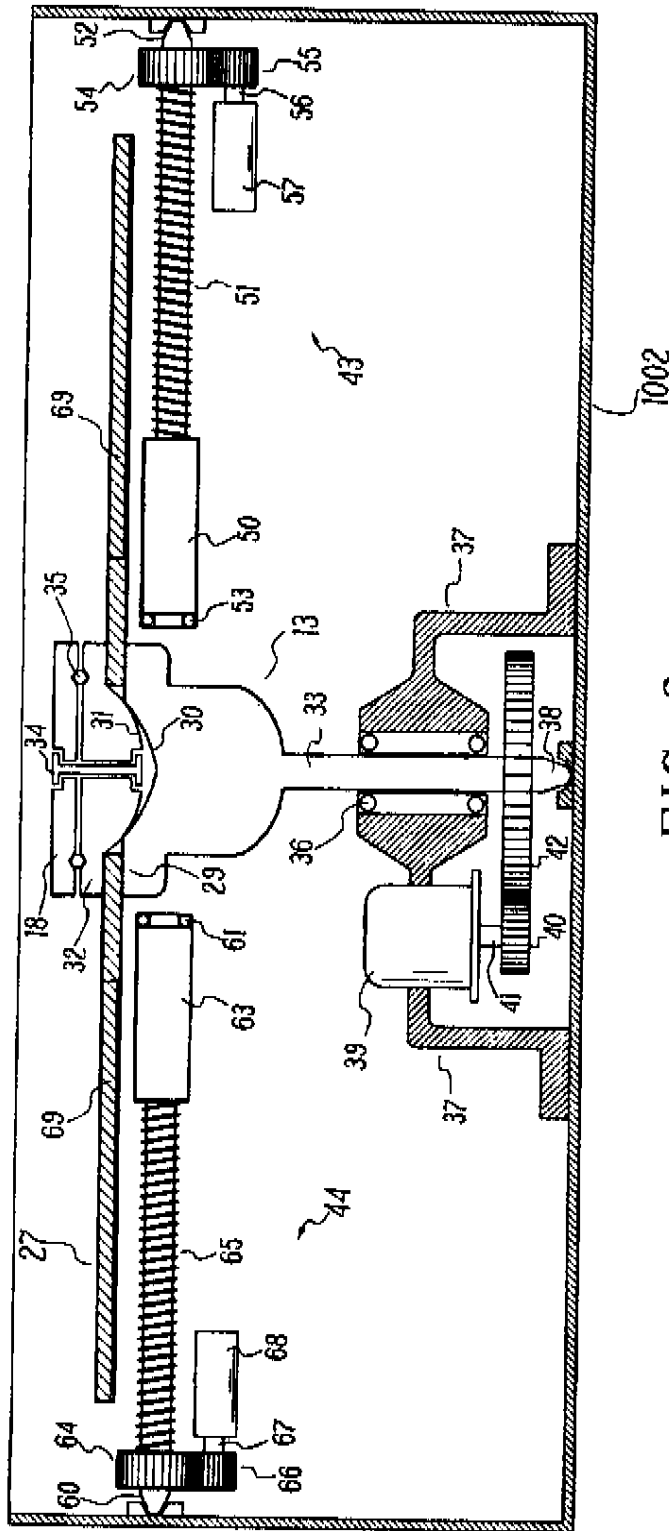

FIG. 2

U.S. Patent

May 5, 1998

Sheet 3 of 15

5,748,575

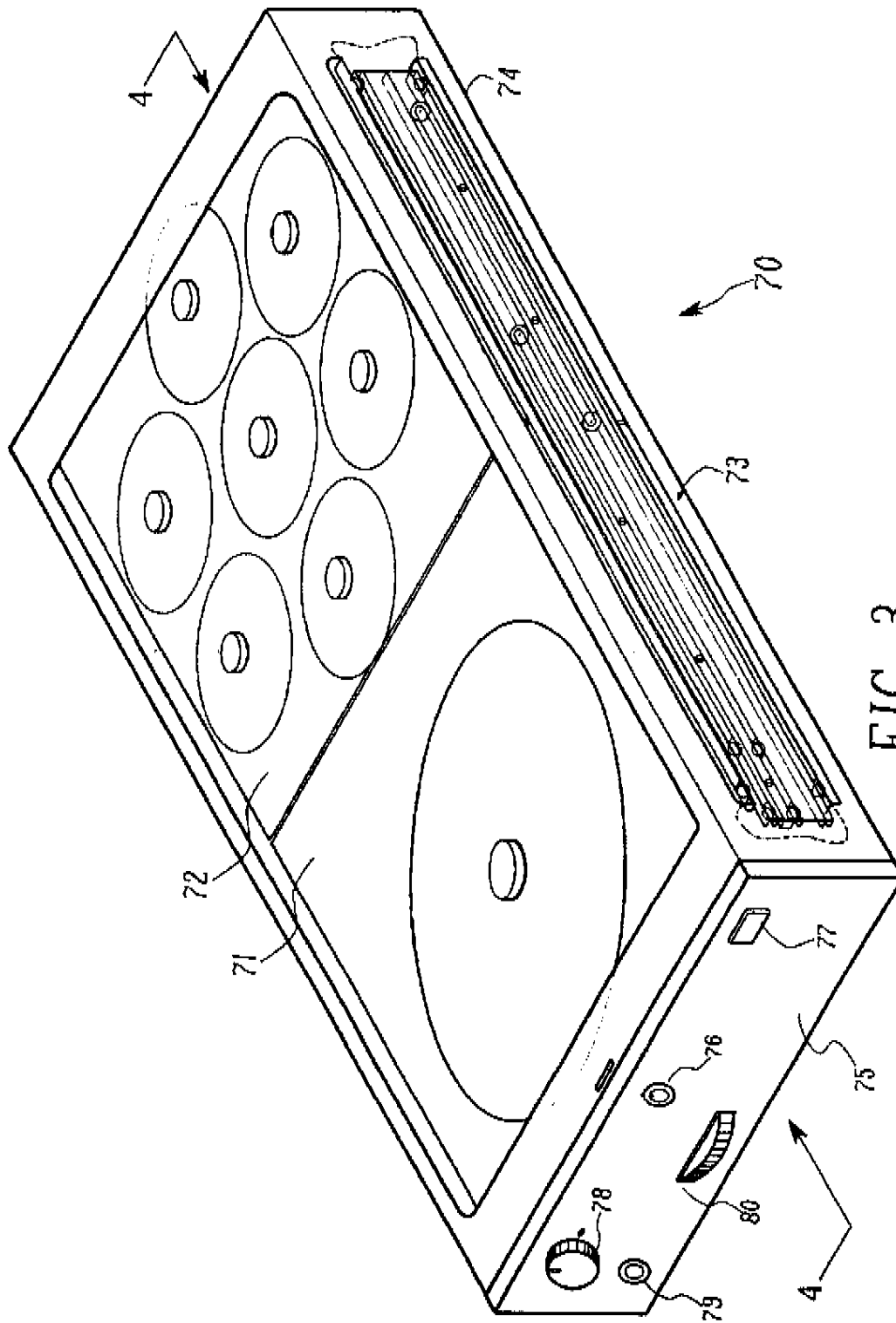

FIG. 3

U.S. Patent

May 5, 1998

Sheet 4 of 15

5,748,575

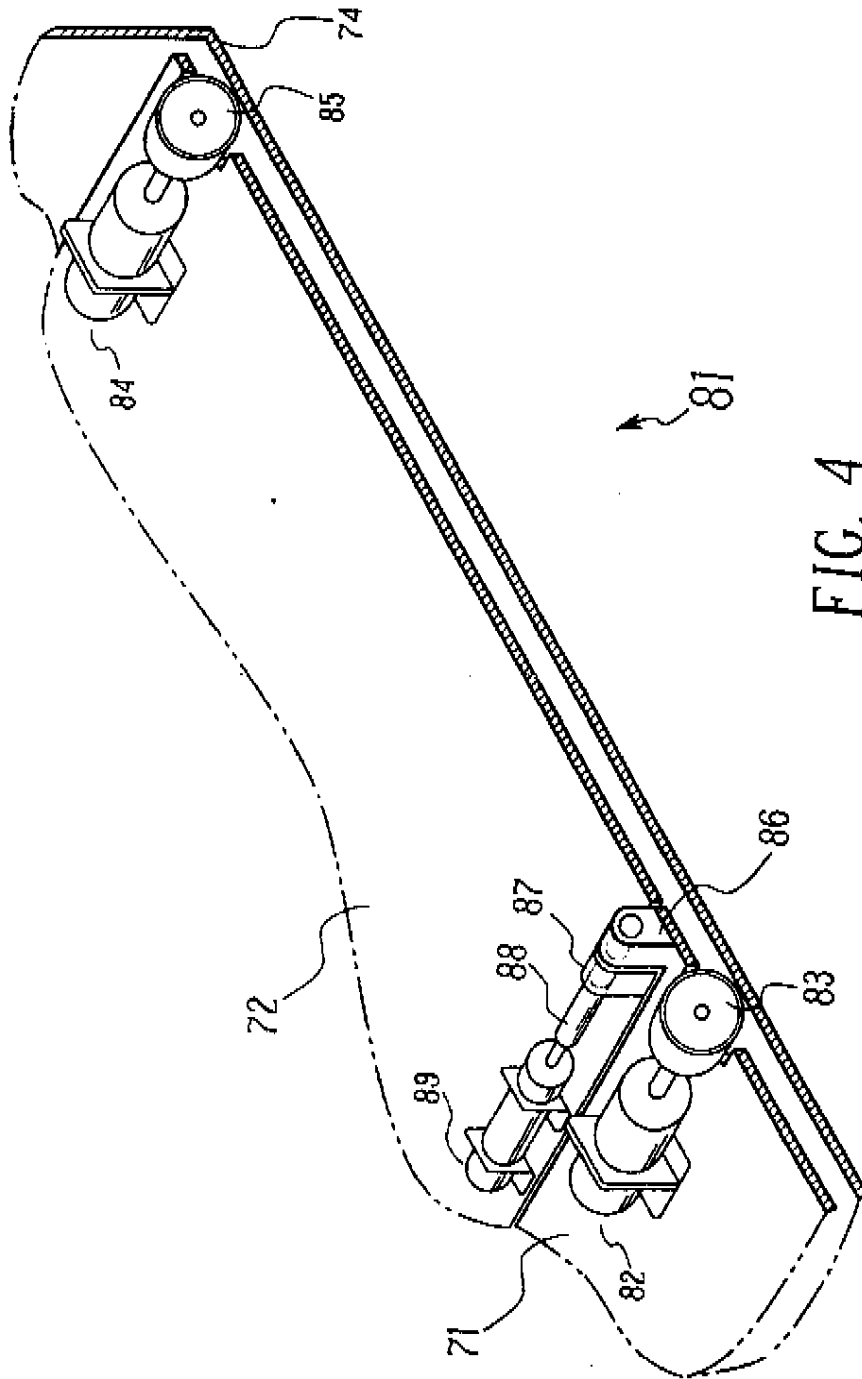

FIG. 4

U.S. Patent

May 5, 1998

Sheet 5 of 15

5,748,575

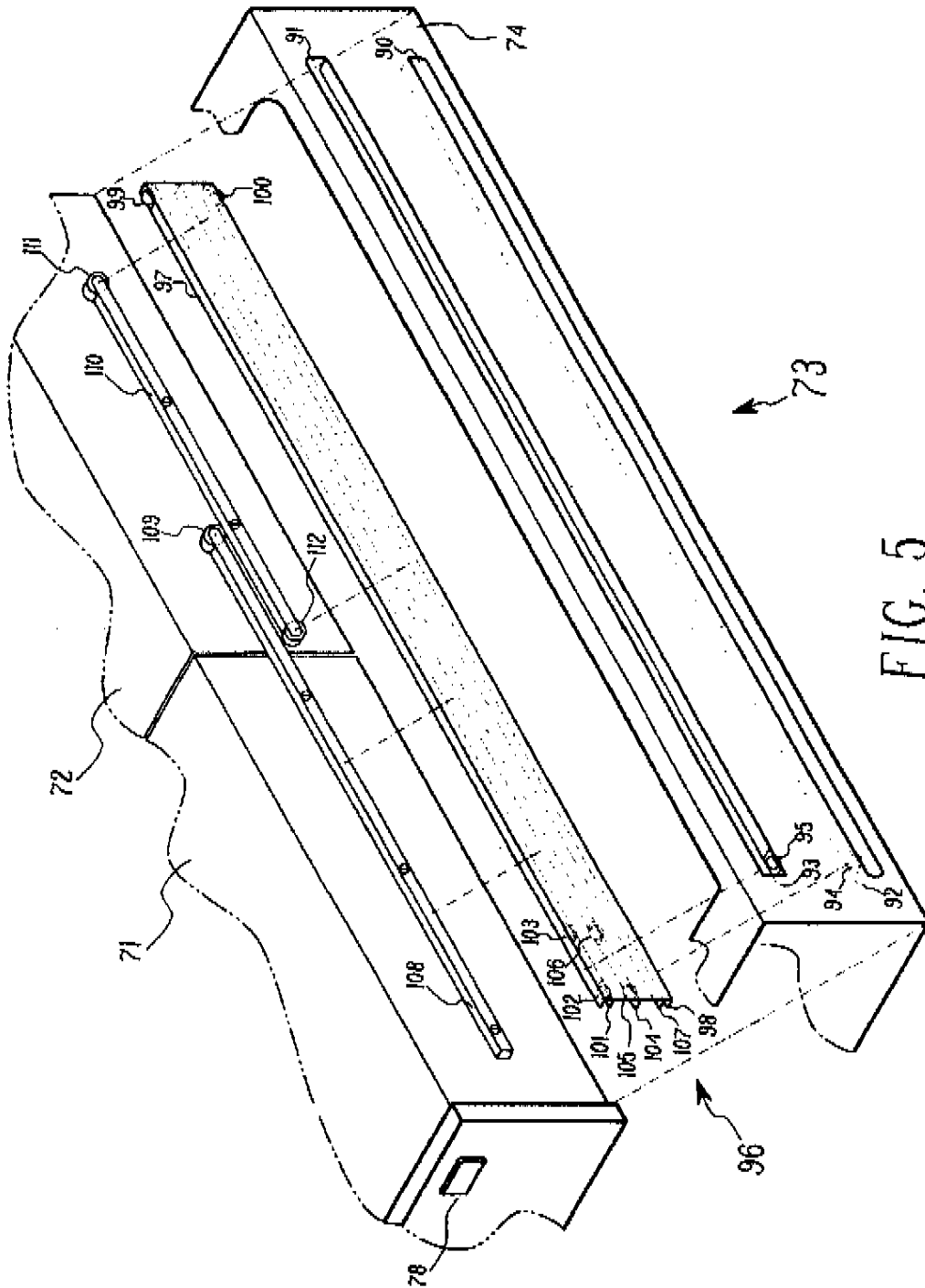

FIG. 5

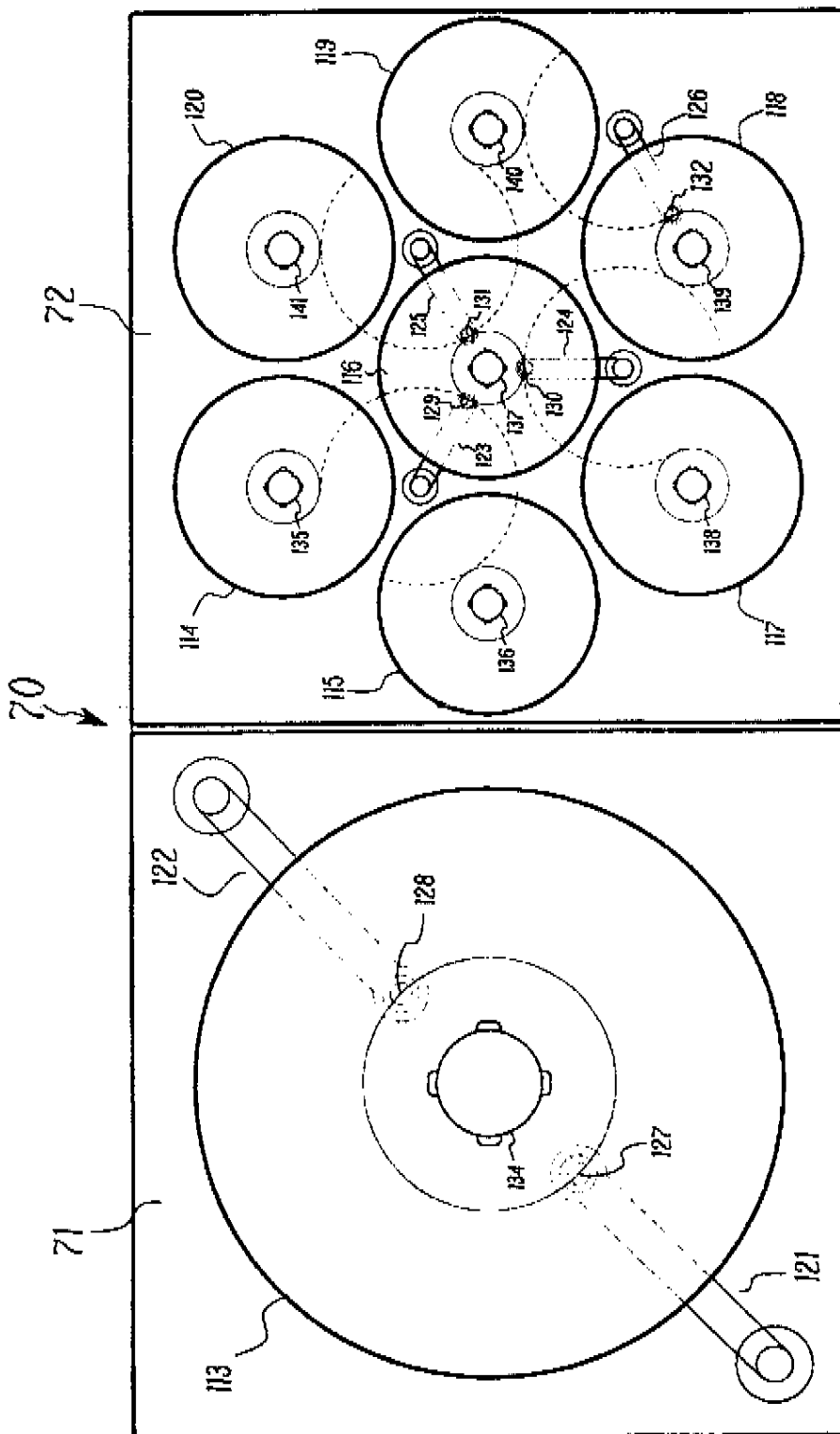

FIG. 6

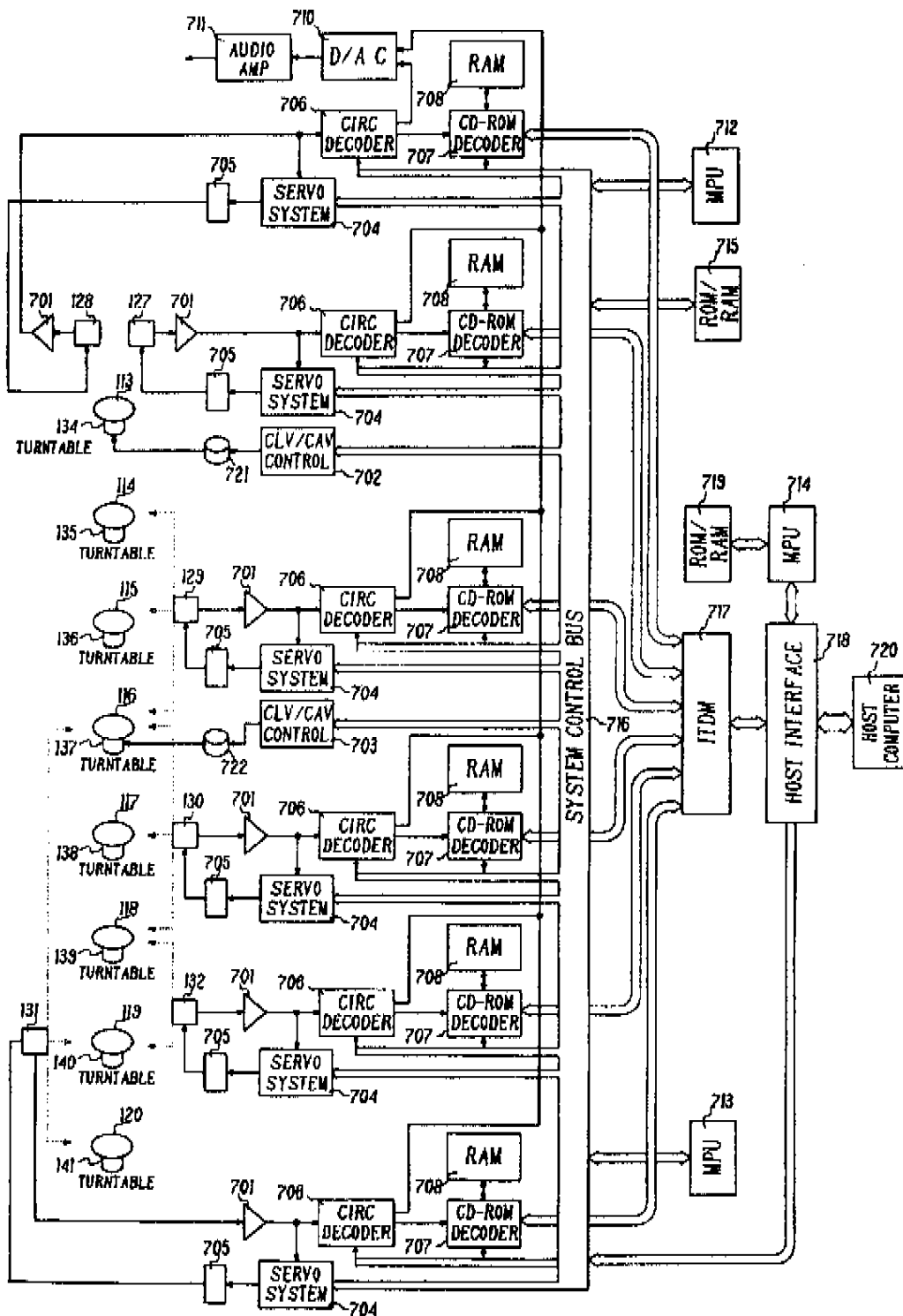

FIG. 7

U.S. Patent

May 5, 1998

Sheet 8 of 15

5,748,575

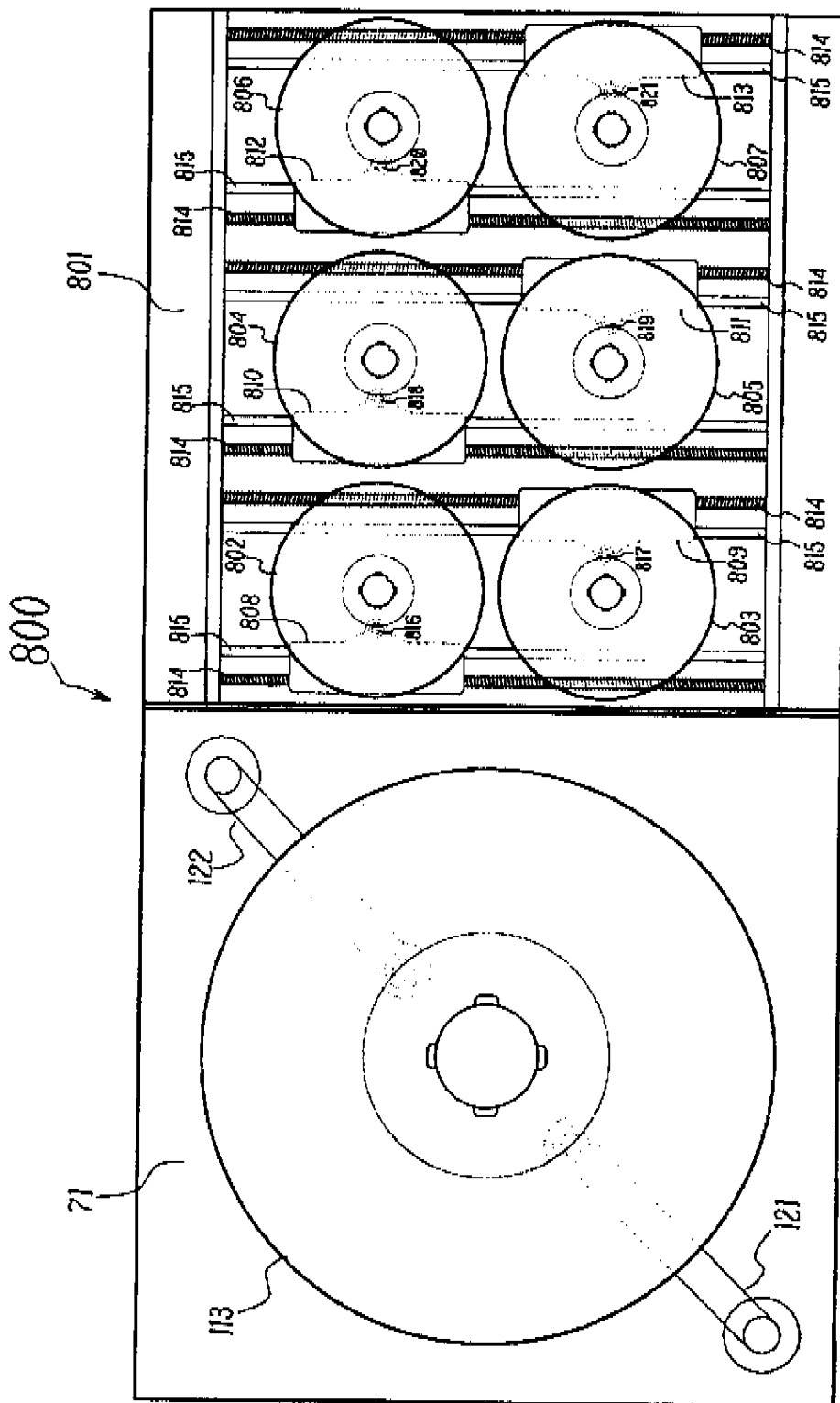

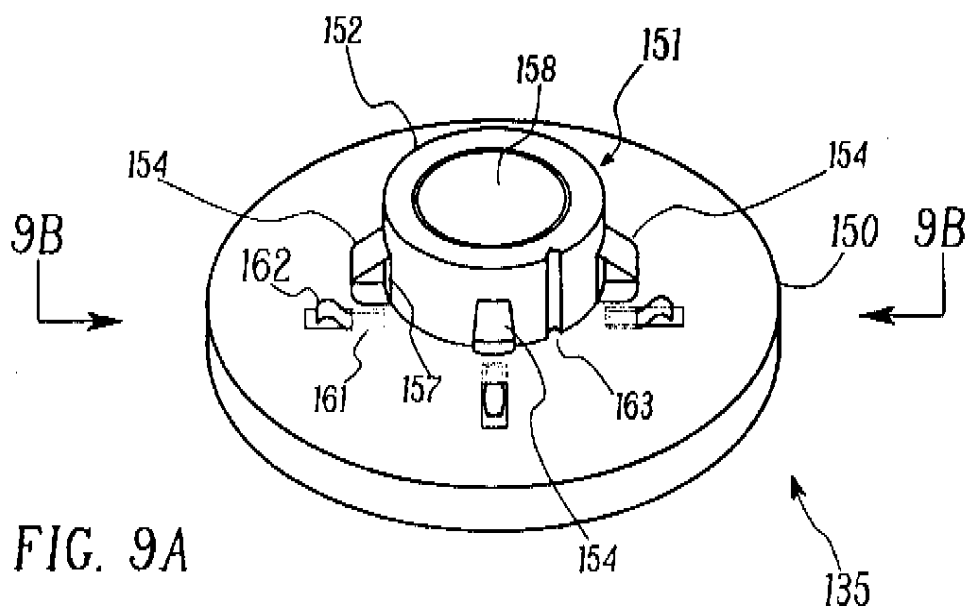

FIG. 9A

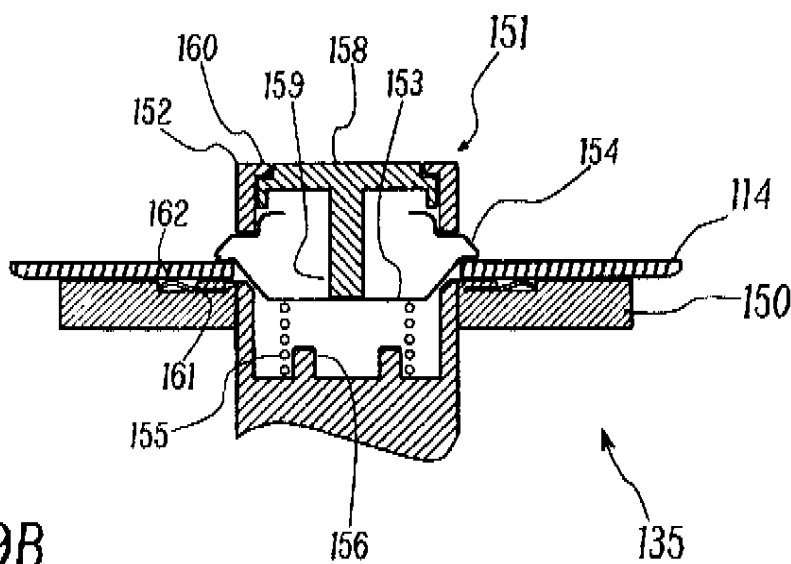

FIG. 9B

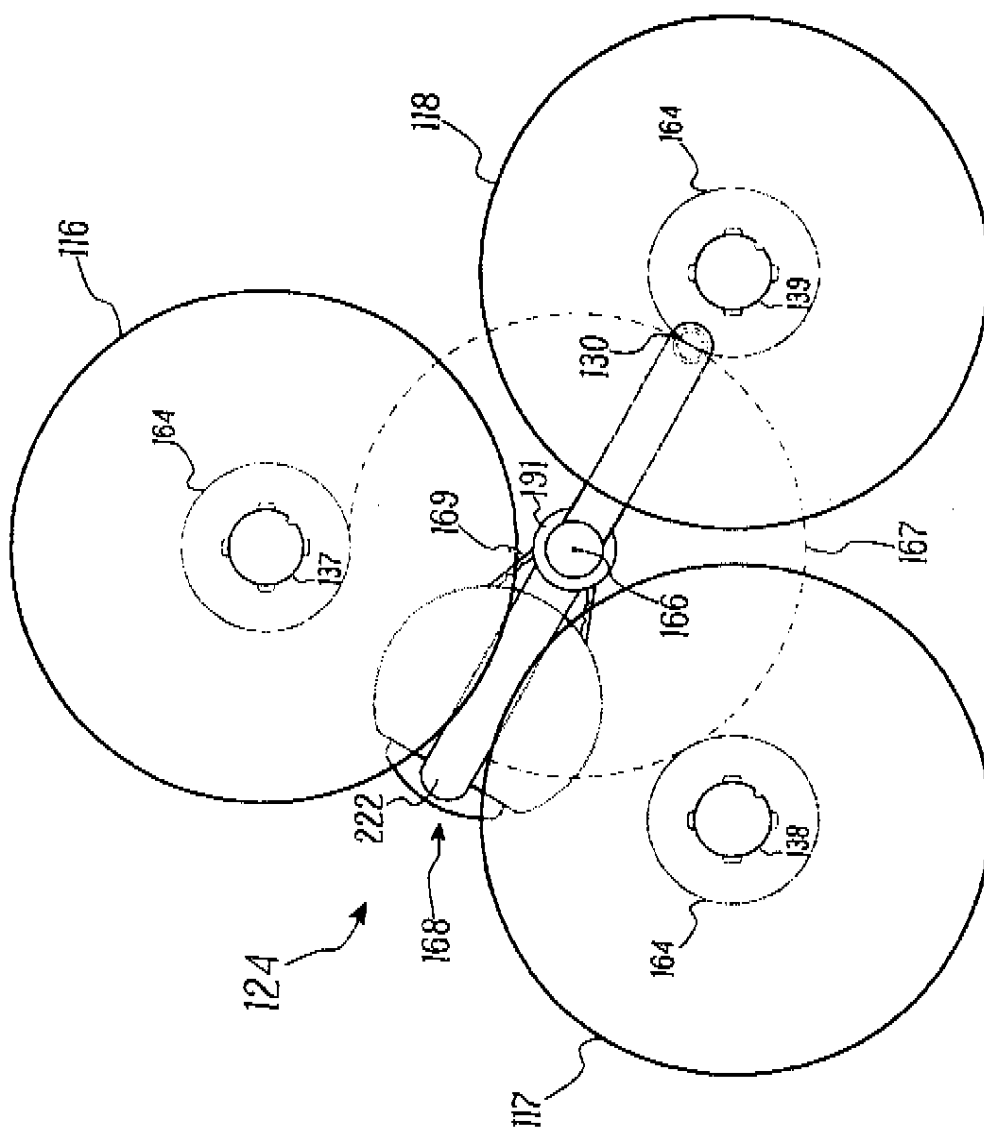

FIG. 10

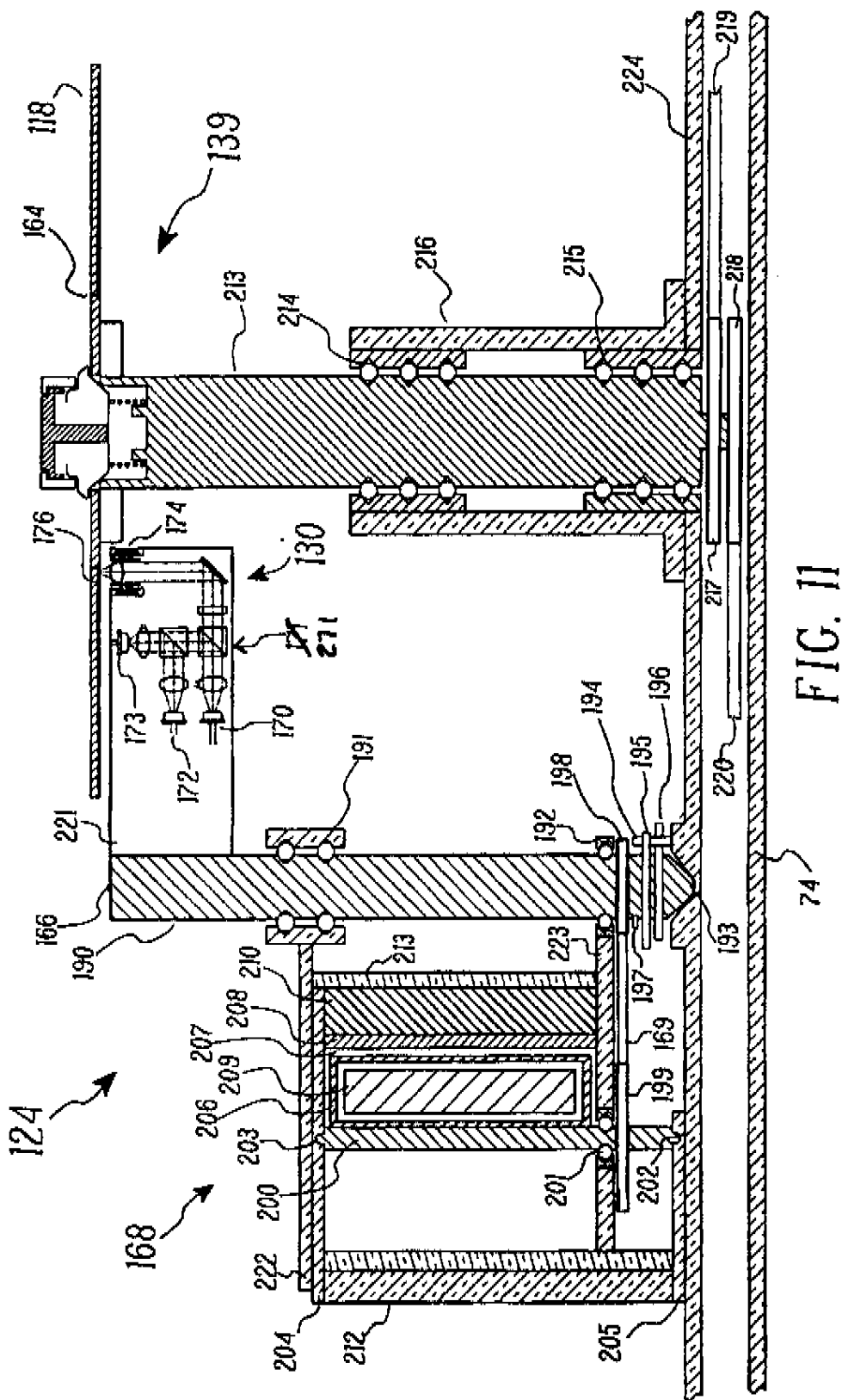

FIG. II

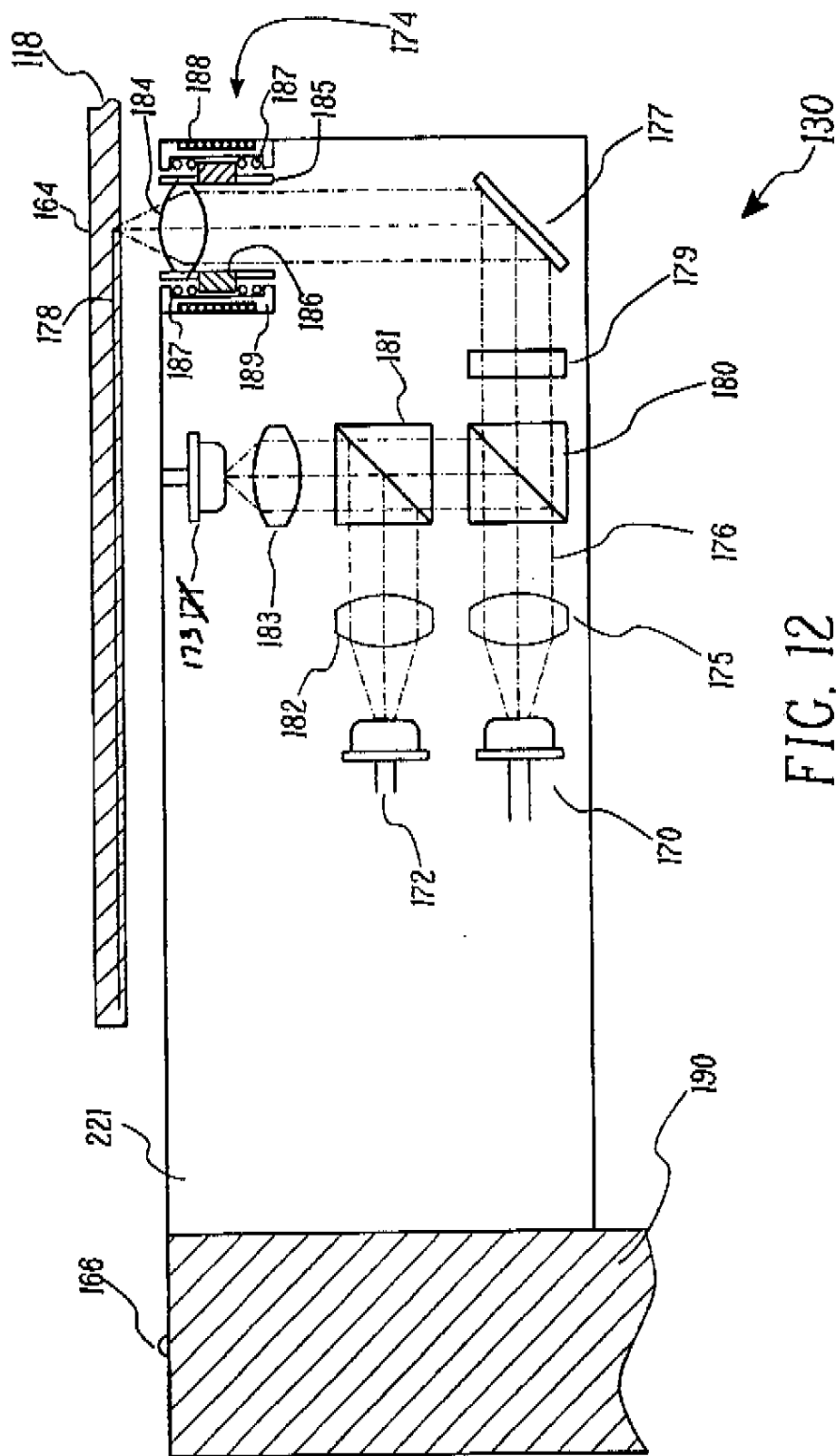

FIG. 12

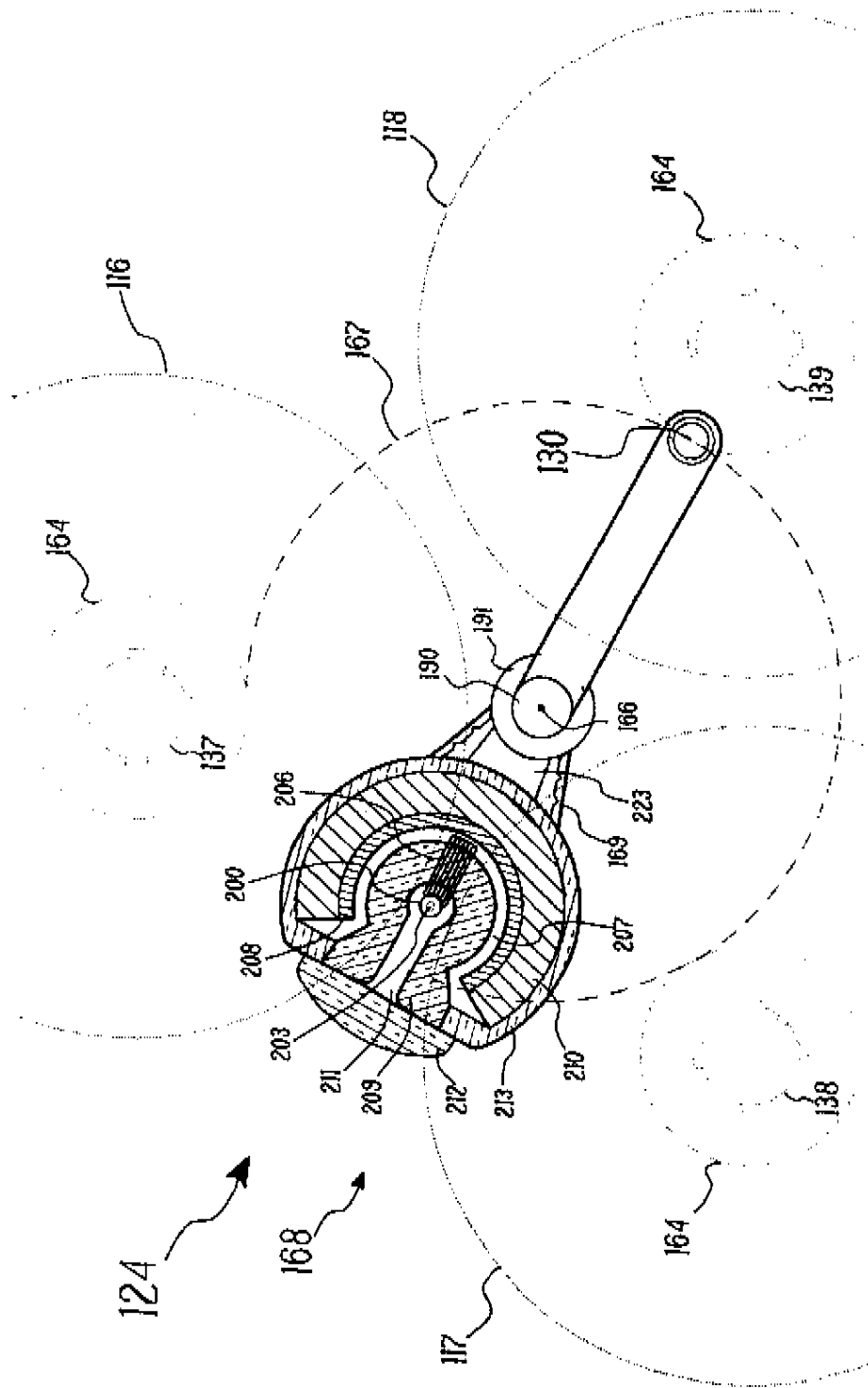

FIG. 13

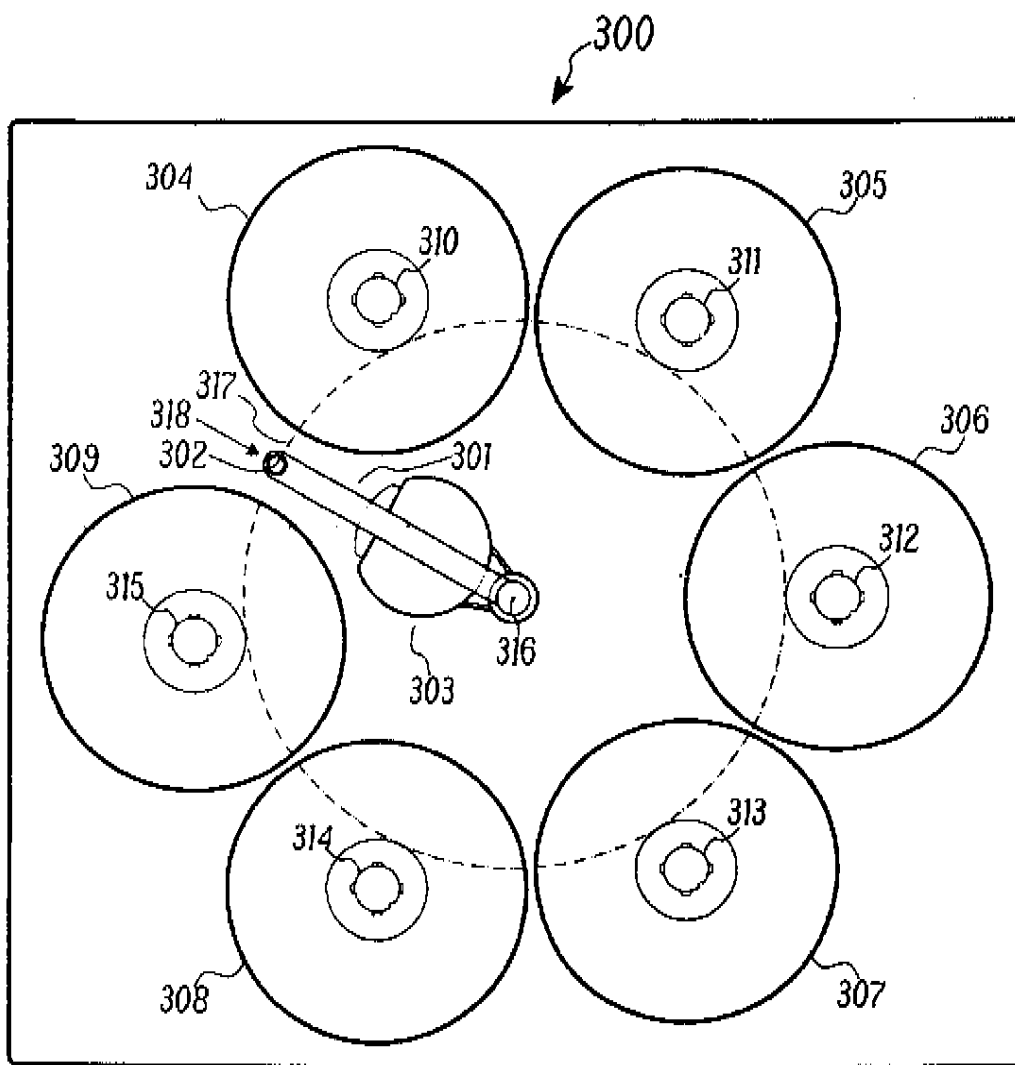

FIG. 14

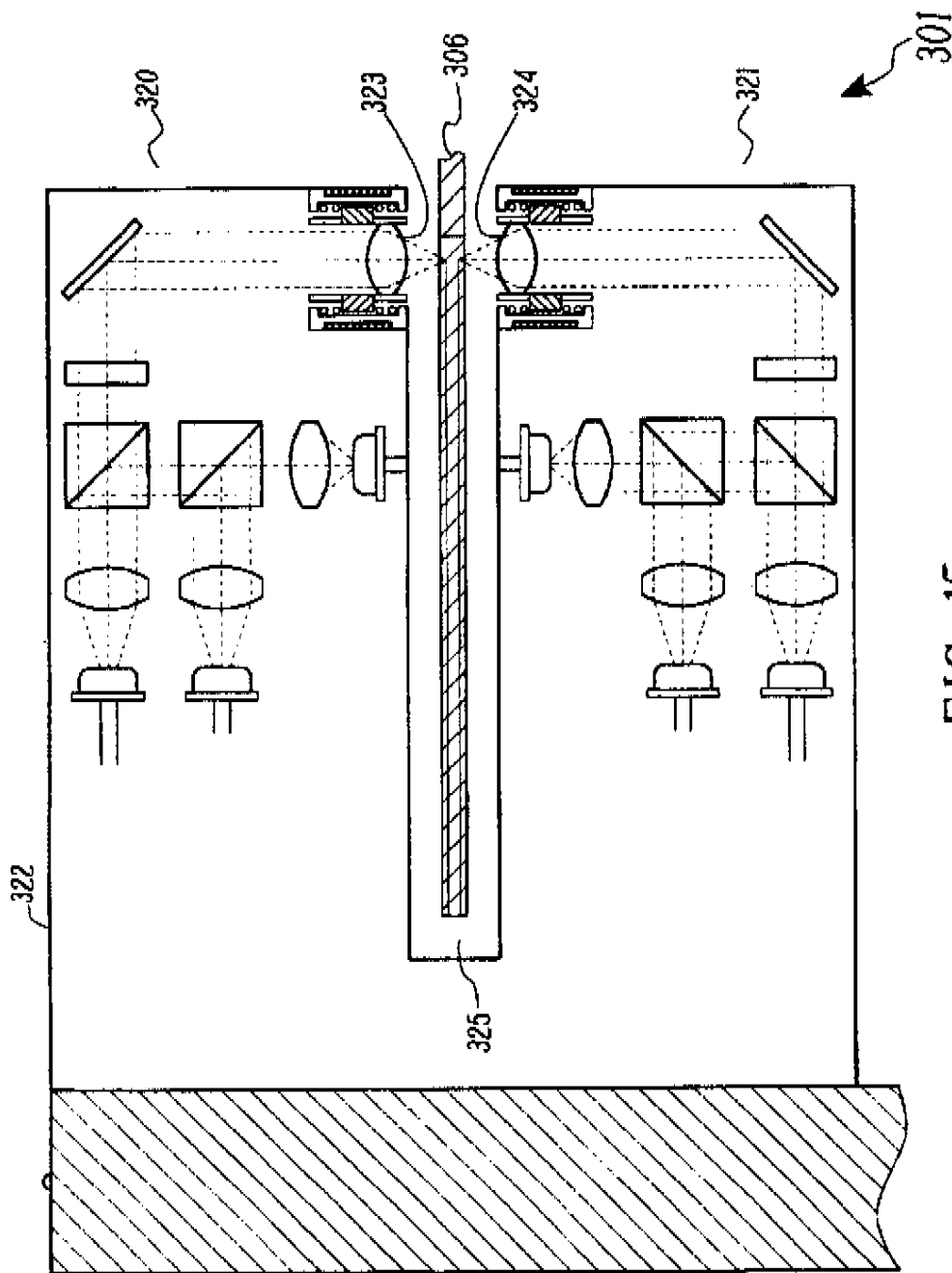

FIG. 15

5,748,575

1

**INFORMATION PROCESSING APPARATUS
HAVING A MULTITASKING FUNCTION
WITH ONE OR MORE OPTICAL DISCS**

FIELD OF THE INVENTION

The present invention relates generally to the field of information processing utilizing optical discs and particularly to a high-efficient optical-disc-type apparatus that allows a host computer to effectively and/or multitaskingly perform various information processing actions directly from optical discs so as to alleviate the heavy burden of a hard-disk drive in the process of information reproducing.

BACKGROUND OF THE INVENTION

An optical disc or compact disc (CD) is made from a transparent plastic material with a thickness of about 1.2 mm that contains a protected thin metal film wherein pits (or depressions) are formed. The pits have light reflectivities different from the light reflectivity of nonpitted portions of the metal film, thus forming a series of 0s and 1s for digital storage of data. In production, a master disc is first developed from a glass disc coated with a uniform layer of photoresist material that is subjected to a series of exposures to a high-power energy beam or laser for forming various pits via the technology of photolithography. The master disc is then used to develop a nickel mother for use in stamping out multiple copies of the discs in transparent plastic material. Each of these is then coated with a thin metallic reflecting layer and then with a protective polymer coating on top of that. When reproducing the stored information, a low-power laser is used to sense the presence or absence of pits. Because a laser beam can be so focused, adjacent tracks of the spiral of pits need be no larger than 1.6 μ m. As a result, one side of a typical 120-mm (4.72-in) CD can have 20,000 tracks for holding a minimum of 500 megabytes of data which can easily store the text of a 20-volume encyclopedia, while both surfaces of a typical 133-mm (5.25-in) or a 89-mm (3.5-in) floppy disk are able to respectively hold only 1.2 or 1.44 megabytes.

Owing to the nature of their high storage capacity, optical discs are especially suitable for storing information requiring or taking large storage spaces, such as patent information, video data, and digital audio files. In addition to the floppy-disk version, software developers have recently produced the 120-mm read-only-memory CD (CD-ROM) version of executable software programs, such as IBM® OS/2 and Microsoft Windows® 95 for use in personal information processing apparatuses, such as desktop- or notebook-type computers.

Even though becoming increasingly popularly equipped in computers, a CD-ROM drive plays a much less significant role in information processing when compared with a hard-disk drive that utilizes the magnetic recording technology. This is because the currently available computers are designed to execute a program or software basically through reproducing the information stored on hard-disk drives, especially when the size of a program exceeds the storage capacity of a floppy disk. When sold to an end user, a software program for use in applications such as disk controlling, word processing, spread sheet, drawing, and presentation making, is compressedly stored on a plurality of floppy disks or an optical disc. Regardless of being either stored in floppy disks or an optical disc, a purchased software program needs to go through a tedious software installation process through which all program files are decompressedly copied to a hard-disk drive wherefrom the

2

software program is then executed. In accordance with this conventional practice, the storage space of a hard-disk drive is quickly filled up. This not only incurs indirect cost in the expenditure of the hard-disk drive in addition to the price of the purchased software program to the end user, but eventually slows down the read-and-write operation efficiency of the hard-disk drive because any data files created are constantly rewritten, fragmentally relocated, and eventually scattered all over the hard-disk drive. Accordingly, a longer time is needed to find all of the data of a particular file. The only remedy currently available for this problem is to routinely run a hard-disk maintenance process in order to remove file fragmentation. Unfortunately, as more software programs or data files are stored on the hard-disk drive, the hard-disk maintenance process becomes more and more time-consuming, because it also involves relocation of the program files that occupy most of the space of the hard-disk drive but are never changed or altered throughout the entire life of their usage. Still there is another concern that a hard-disk drive is subject to nonphysical damages, for instance, such as program files being truncated or cross-linked due to improper assessing or writing during information reproducing or being infected by computer virus. As a result, a software program becomes corrupted; and, another tedious software installation process is again needed. All of these point to the fact that the currently available computers are designed to perform information processing by reproducing the information stored on hard-disk drives, and, this is not necessarily desirable.

Since a software program is mostly stored on a plurality of floppy disks for its distribution, an end user is routinely advised to make a set of backup copies because floppy disks are susceptible to physical and external damages. Inevitably another disadvantage is incurred: a time-consuming process for making backup copies.

The need to install a purchased software program to a hard-disk drive further incurs another problem: it is extremely difficult for software developers to stop or prevent illegal-copying of software. There are existing hardware-type protection devices and password-type protection approaches but they are affordable only for high-price software programs with an aim of selling at most a few thousand copies for use in trading stocks or futures in real time, for instance. In contrast, volume software programs are sold in sealed envelopes. Once a sealed envelope is opened, an end user is assumed to accept the software license agreement set by a software developer and, the software program is not returnable. Unfortunately, there is no practical way to prevent an end user from illegally copying such a software program. As the software developers producing high-volume and low-price software programs suffer from their products being illegally copied, the consumers lose their opportunity to try out a software program before purchasing.

In view of the disadvantages and problems mentioned hereinbefore, it is clear that currently available computers and optical disc or floppy-disk apparatuses are not designed to achieve their optimal potential. Owing to the nature of durability and storage capacity far superior to that of a floppy disk, an optical disc has a greater potential to become a memory storage medium for constructing a special type of apparatus to remedy the disadvantages currently encountered in the available information processing apparatuses. Thus, main interest of the present invention is to design a high-efficient optical disc apparatus wherefrom software programs can be directly launched so as to eliminate the tedious, time-consuming software installation and thus to

5,748,575

3

offer an alternative of copy-right protection to software developers, as well as to alleviate the heavy burden of a hard-disk drive in information processing. Also essential for an information processing apparatus of this type is the feature of disc-loading and -unloading flexibility that allows a user to easily change or replace desired discs at will. In order to achieve the highest efficiency in information reproduction, any disc and disc positions should be readily accessible by at least one optical unit at any time. An optical read head should be able to travel from one disc to another, and its travelling should be limited to one-directional movement (either linear or circular) because multiple-directional or three-dimensional movement greatly slows down optical-read-head travelling efficiency. It is also highly desirable that an information processing apparatus of this type in accordance with the present invention comprises multiple disc sites each able to detachably hold a disc so that various software programs are readily available because Microsoft®, WordPerfect®, or Lotus® are most likely to produce their own software discs.

Multitasking or multiprocessing is another highly desirable feature for an information processing apparatus of this type in accordance with the present invention. In the context of the present invention, multitasking or multiprocessing is defined as referring to separate hardware control units that allow execution of separate or several software programs simultaneously. Due to containing a plurality of discs wherefrom several programs can be directly launched, an information processing apparatus of this type needs a safeguard device to prevent the discs stored therein from being unauthorizedly removed. Further, this type of information processing apparatus should be compact enough to be internally installed in a computer, because with the trend towards miniaturization, no future computers would be spacious enough for internally storing a bulky CD apparatus holding more than two horizontally spaced 120-mm discs.

An information processing apparatus of this type with all or a selected combination of the features mentioned hereinbefore is not yet readily taught by the prior arts. This is discussed as follows.

U.S. Pat. No. 4,644,515 describes a laser-disc digital data video storage system in which multiple discs stacked upon a common rotatable drive shaft are to be read by a plurality of stationary read head arrays for commercial use. This jukebox-like system allows multiple users to access its information by employing a huge number of read heads, for example 55,000 heads (or one head for each track), in each read head array. One of the main disadvantages of this type of system is its lacking disc-loading and -unloading flexibility; that is, a user cannot access the common drive shaft for changing or replacing a desired disc at will. U.S. Pat. No. 4,888,751 describes an image information processing system in which (at least) an optical unit having an optical head arm rotatable through 180 degrees is used to scan the information stored on either adjacent side of multiple discs that are stacked at predetermined intervals on a detachable mounting mechanism. The detachable mounting mechanism provides some improvement in disc-loading and disc-unloading flexibility over U.S. Pat. No. 4,644,515 mentioned above, but is still inconvenient for a user to replace or change a desired disc at will due to the stacking nature of its disc arrangement. This prior apparatus is afforded with a plurality of optical units such that one of the optical units is most likely readily available for vertically moving to a next selected disc. In such a manner, the process of accessing information recorded on a different disc is speeded up; otherwise, the access time will be unacceptably slow since

4

an optical unit in such a system has first to retract out of a disc space by swinging, to move vertically to a new disc space to be entered, and then to seek a new track by swinging. In this prior art, it is obvious that the presence of the multiple optical units is intended for speeding up disc-track access time between discs, but not for achieving any multitasking.

To improve the access time for reproducing the information stored on different discs, U.S. Pat. No. 5,189,652 describes a stationary-type optical disc apparatus that is characterized by a plurality of optical units each slidable into a disc space to access a predetermined position of a disc. Although it reduces the access time, this system neither affords disc-loading and -unloading flexibility referred to above because of its stationary and disc-stacking natures, nor provides any multitasking capability.

Instead of using the approach of stacking as used in the abovementioned prior arts, U.S. Pat. No. 4,722,078 employs a plurality of horizontally spaced disc compartments (or trays) each holding an audio disc which, upon selection can be scanned by a disc playback module that is capable of being horizontally transported between the disc compartments. Because each disc compartment has a separate means for independently extending and retracting out of and into the apparatus, this audio CD player requires multiple front entrances. In other words, this configuration is too bulky and cannot be internally installed into the existing drive bays of current computers, which typically have dimensions of 146-mm (5.75-in) in width, 41-mm (1.75-in) in height, and up to about 254-mm (10-in) in depth. In addition, it lacks multitasking capability.

Other examples using the nonstacking approach are embodied in U.S. Pat. Nos. 5,146,451, 5,193,079, and 5,251,192. However, in accordance with these prior arts, discs are not readily accessible at any time because their disc-storage sites need to move to a predetermined position before a selected disc becomes accessible, thus slowing down information-reproduction efficiency. Similar inefficiency is also seen in U.S. Pat. Nos. 5,119,354 and 5,335,218 that utilize a disc transfer means comprising a drive roller to deliver a disc selected from a disc container or magazine (having a plurality of discs in a pile therein) to a disc drive for rotating and thus reading. Although improving disc-loading and -unloading flexibility referred to above, all of these prior apparatuses with capability of holding a plurality of discs require several additional transitional stages before a selected disc becomes accessible to a singular optical unit. These apparatuses are best for use in as-intended audio applications, not for use in information processing that requires high-efficient, high-speed information reproduction.

Providing disc-loading and -unloading flexibility to some extent, U.S. Pat. No. 5,043,963 provides an information processing apparatus capable of playing a disc selected from a plurality of sizes such as 80-, 120-, 200- or 300-mm in diameter. These multisized discs are laid on a tray wherein a circular-like section used to store a plurality of small-sized discs is rotatable for their selection. Different versions of apparatuses capable of playing optical discs with different diameters are seen in U.S. Pat. Nos. 5,119,354 and 5,253,235. The ability of playing the discs with different diameters is desirable, however, the discs in these prior apparatuses fail to be readily accessible by their single optical unit at any time.

In the conventional CD apparatuses, a single clamp device (or press member) capable of pivoting downwardly

5,748,575

5

or upwardly is often used to pinch a disc mounted to a drive shaft or turntable for rotating. Clamp devices of this type are embodied in U.S. Pat. Nos. 4,722,078, 5,146,451, 5,251,192, and 5,253,235. Those are not suitable for use when a plurality of discs need to be in a readily-accessible state at any time. U.S. Pat. No. 5,375,113 describes a simple clamping mechanism for each of a number of turntables, which is desirable. However, it remains to be seen whether the clamping mechanism can provide necessary clamping force and at the same time can afford an easy release of a loaded disc. Accordingly, there is a need to design a simple, yet effective and space-saving disc-clamping device with disc-loading and -unloading flexibility for use in the information processing apparatus in accordance with the interest of the present invention.

In order to simultaneously launch several software programs directly from either an optical disc or multiple optical discs in accordance with the interest of the present invention, the hardware of an information processing apparatus must possess multitasking capability. This requires not only having a plurality of optical units but also a variety of signal process means (such as decoders), control means (including a plurality of microprocessors or a microprocessor with multitasking capability) and data transmitting means that all coordinately work together for reproducing plural sets of data simultaneously from various disc positions on a disc or on several discs and at the same time transmitting them to a host computer. Otherwise, optical units cannot be instructed to independently and simultaneously move to a plurality of predetermined disc positions, and plural sets of data retrieved from discs cannot be simultaneously processed for returning back to their original state and then transmitted to a host computer. Thus, plural discs and optical units will make an information processing apparatus more efficient in terms of access time, but will not necessarily arrive at any multitasking nature needed for future high-speed information processing. One example is exemplified in U.S. Pat. No. 5,375,113 which describes an apparatus that has a plurality of disc storage sites (in nonstacking form), each having a separate drive means and an optical disc situated together, for reading data specifically from one single, selected optical disc. The main object of the prior art is to eliminate much of the costly and duplicative hardware found in systems utilizing drive cartridges so that common control means such as latches, demultiplexers, and multiplexers are used in order to fulfill its main object for delivering a power signal to a selected single disc storage site for activating its drive means to read information from its respective disc. Even though various electronic configurations are given, the prior art utilizes only one single microprocessor for instructing which drive means should be turned on or which servo control device should be activated. Under the circumstances, it is not possible to simultaneously issue multiple commands or control signals to activate and thus to control a plurality of drive means for performing information reproduction from plural discs at the same time. In essence, the prior apparatus is specifically designed for information reproduction to take place one at a time in a selected disc storage site; thus, it lacks a multitasking capability. This is further substantiated in the fact that throughout the entire context, this prior art neither mentions nor even suggests retrieving information simultaneously from plural discs and sending plural sets of retrieved information at the same time to its host computer, which are all essential for multitasking to take place.

It is clear that each of the current CD apparatuses has its own merit but all suffer from various types of disadvantages,

6

such as being unable to launch programs directly from optical discs, lack of multitasking capability, the inability for all discs and thus disc positions to be in a readily accessible state with respect to at least one optical unit at any time, lack of disc-loading and -unloading flexibility, lack of flexibility for optical units to travel between discs, lack of an efficient means for an optical read head to selectively travel between discs, too bulky to be installed in a host computer, and/or lack of a device to safeguard optical discs from being unauthorizedly removed.

SUMMARY OF THE INVENTION

A primary object of the present invention is to provide an information processing apparatus with multitasking-capability hardware so that a plurality of optical units are capable of independently and simultaneously moving to a plurality of disc positions, making it possible to launch one or several software programs directly from the information processing apparatus, to provide true multitasking capability, to eliminate tedious and time-consuming software installation, to offer a kind of copy-right protection, and to alleviate the burden of a hard-disk drive in information reproduction processing.

Another object of the present invention is to provide an information processing apparatus with turntables having disc-loading and -unloading flexibility, wherein each turntable comprises a disc-holding and -releasing means with self-clamping and self-releasing feature for each optical disc.

Another object of the present invention is to provide an information processing apparatus with turntables and optical units being arranged in a particular manner, wherein each optical unit comprises an efficient driving means for moving at least one optical read head selectively between discs so that several optical read heads are able to independently move to a plurality of predetermined disc positions on the same disc surface of a selected optical disc for simultaneously retrieving a plurality of information stored thereon.

Another object of the present invention is to provide an information processing apparatus with turntables and optical units being arranged in a particular manner so that the same driving mechanism is used to move the optical read head of each of said optical units selectively between disc position and between discs, for greatly improving information access efficiency when an optical unit needs to move between discs.

Another object of the present invention is to provide an information processing apparatus with a variety of control means (including a plurality of microprocessors or a microprocessor with multitasking capability) so that at least two optical units are able to work coordinately and simultaneously on separate portions of a software program, for greatly improving efficiency in information reproduction.

Another object of the present invention is to afford an information processing apparatus with a security means to safeguard the optical discs stored therein from being unauthorizedly removed.

Another object of the present invention is to provide an information processing apparatus with a plurality of disc compartments so that it is possible to replace an optical disc in one disc compartment while the other optical discs stored in another disc compartment remain operating.

Another object of the present invention is to provide an information processing apparatus with a control means to allow a disc to be scanned either at a constant angular velocity (CAV) method or at a constant linear velocity (CLV) method.

5,748,575

7

Another object of the present invention is to provide an information processing apparatus with at least one turntable that can accommodate an optical disc with different disc diameters, affording greater application flexibility.

The present invention improves the conventional information reproduction practice by providing an optical information processing apparatus with multitasking-capability hardware and disc-loading and -unloading flexibility means, thereby allowing a user to launch a software program or simultaneously a plurality of software programs directly from an optical disc or several optical discs stored therein. The multitasking-capability hardware of the present invention comprises a plurality of turntables, optical units, control means, signal-process means, and data transmitting means to coordinately work together for multitaskingly retrieving, controlling and transmitting a plurality of information simultaneously from various position of a disc or several discs to a host computer. Turntables and optical units are arranged and rendered in a particular manner such that at least one optical unit can access any positions of at least two discs, a plurality of optical read heads situated in said optical units can independently and simultaneously access a plurality of positions on the same surface of a disc for high-speed information processing and/or a plurality of positions of separate disc surfaces for multitaskingly perform several programs at the same time. In accordance with the present invention, the number of optical units can be less as compared with that of turntables, for reducing the production costs of making an optical information processing apparatus while maintaining high efficiency in information reproduction.

An optical information processing apparatus of this type is optionally equipped with a plurality of disc compartments so that one disc compartment can be independently open for disc exchanging while the other disc compartment remains closed and active programs remain operating, with a disc holding means having self-clamping and self-releasing feature to facilitate disc-loading and -unloading operation, with at least one turntable capable of accommodating a disc with various disc diameters, with a control means to allow a disc to be scanned either at a constant angular velocity (CAV) method or at a constant linear velocity (CLV) method, and/or a safeguard mechanism.

BRIEF DESCRIPTION OF THE DRAWINGS

FIG. 1 is a perspective view of a multitasking information processing apparatus in accordance with the present invention having two optical units capable of being used to reproduce information simultaneously from two different positions of an optical disc.

FIG. 2 is a cutaway side view taken along the line 2-2 of FIG. 1, schematically showing an arrangement of the multitasking information processing apparatus.

FIG. 3 is a perspective, partial-cutaway view of a multitasking information processing apparatus of the present invention showing a plurality of multisized discs set in two disc compartments and a disc-compartment transporting means for the front disc compartment to be able to be separately drawn out and into the playhousing.

FIG. 4 is a cutaway view of the underside of the sub-chassis traverse driving mechanism taken along the line B-B in FIG. 3 of the present invention.

FIG. 5 is an exploded perspective view of the disc-compartment transporting means seen in FIG. 3 of the present invention.

FIG. 6 is an illustrative top plan view of the multitasking information processing apparatus seen in FIG. 3 with six optical units and eight optical discs.

8

FIG. 7 is a block diagram of a control system of the multitasking information processing apparatus shown in FIG. 6 of the present invention.

FIG. 8 is an alternative configuration of turntables and optical units.

FIGS. 9A and 9B are perspective top and cutaway side views respectively, for the turntable having a disc-holding and -releasing means with self-clamping and self-releasing feature in accordance with a the present invention.

FIG. 10 is a perspective top view of an optical unit as used in FIG. 6 that is able to access any position among three disc by horizontally swinging in accordance with the present invention.

FIG. 11 is a cutaway view of an optical unit with an optical read head and a driving mechanism, and a turntable with a disc-holding and -releasing means in accordance with the present invention.

FIG. 12 is an illustrative, cutaway side view of an optical read head in accordance with the present invention.

FIG. 13 is an illustrative top view of an optical unit of the present invention comprising a driving means in a cutaway top view that enables an optical read head not only to take a predetermined position on a disc but also to travel between three discs.

FIG. 14 is an illustrative top view of a single optical unit in accordance with the present invention, having a driving means for allowing at least one optical read head situated therein to travel to at least one predetermined position selectively between a plurality of discs for retrieving information stored thereon.

FIG. 15 is a cutaway view of an optical unit comprising an upper optical read head and a lower optical read head for simultaneously reproducing information stored on both surfaces of a disc.

DETAILED DESCRIPTION OF THE PREFERRED EMBODIMENT

Referring now to FIGS. 1 and 2, one embodiment of the present invention will be described in detail hereinafter.

FIG. 1 is a perspective view of an information processing apparatus 1 with multitasking capability in accordance with the present invention, having two optical units 43 and 44 and one optical disc 27 in a loaded condition. Apparatus 1 has a structural frame 1002 on which various mechanism components are mounted. The frame also serves for the apparatus 1 to be either internally installed as a built-in unit in a computer or covered by a housing for use as a stand-alone unit to be connected to a computer. Provided with apparatus 1 is a front panel 3 having a disc-releasing button 1004 and a disc supplying slot 5 on which there exists a larger opening 6. Disc supplying slot 5 is in a size just allowing an optical disc to be inserted into or extracted out of the apparatus. Larger opening 6 is provided to allow a user's finger to push a disc, being inserted through first guide roller pairs 7 and 8 and then second guide roller pairs 9 and 10 further toward the inside of the apparatus 1, by moving a disc levelling mechanism 11 backward. Disc levelling mechanism 11 has a flat area 12 that is in a horizontal position slightly lower than the disc-setting table 29 (seen in FIG. 2) of a turntable (or spindle) 13 so that a disc is prevented from being tipped over and thus is disposed on disc-setting table 29 during loading. Disc levelling mechanism 11 is slideable along a pair of horizontally disposed guide rails 14 through a pair of bearings 15. When pushed backward to a predetermined position, disc levelling mechanism 11 moves the rear-end

5,748,575

9

portion 16 of a disc clamp arm 17 backward so that a disc clamp head 18 at the distal end of clamp arm 17 is pivoted downward about a fulcrum 19 by compressing springs 20 mounted on the rear portion of guide rails 14 so that a rod 21 connecting disc levelling mechanism 11 to a mechanical holding mechanism 22 is pulled backward. When pulled to a predetermined position, the top portion of a position holder 23 in mechanical holding mechanism 22 is pivoted backward about a fulcrum 24 so as to move the middle portion of position holder 23 over a spring strip 25. The spring strip is arranged to have one end fixed to a support plate 26 and the other end being free, thus allowing the moveover action of position holder 23 to take place whenever there is an external force sufficient to overcome the holding force of spring strip 25. Position holder 23 is held by spring strip 25 against the force of compressed springs 20, and disc levelling mechanism 11 is thus not touching the edge of a disc 27.

During disc loading, disc levelling mechanism 11 is moved backward to a predetermined position so that a microswitch (not shown) activates a solenoid 28 to pivot disc clamp head 18 downward further so as to tightly grip optical disc 27 onto turntable 13 for subsequent rotation. As detailed in FIG. 2, that is a partial cutaway side view taken along the line 2--2 of FIG. 1, on the top of turntable 13 are the disc-setting table 29 for bearing disc 27 horizontally and a concave portion 30 for accommodating a convex portion 31 of disc clamp 32. Together with concave portion 30, convex portion 31 horizontally moves disc 27 to a correct position for gripping and thus for rotation about turntable shaft 33. The top of convex portion 31 is rotatably connected to disc clamp head 18 by a connecting member 34 and is provided with bearings 35 for its rotation. While the top portion of turntable 13 is rotatably stabilized by disc clamp head 18 of clamp arm 17, the middle portion of turntable shaft 33 is rotatably held by bearings 36 mounted on support frame 37 and the bottom end is supported by a pivot 38. Support frame 37 also holds a turntable motor 39. Turntable shaft 33 is rotated by turntable motor 39 through a power transmission system, including a gear 40 mounted on a motor shaft 41 and a gear 42 mounted on the near-bottom end of turntable shaft 33.

Apparatus 1 has two optical units 43 and 44 horizontally supported by a common frame 45 that is held by the top portions of the side panels of structural frame 1002. Optical unit 43 has an optical read head 46 with a lens system 47 for reading the information stored on the lower surface of disc 27. Read head 46 is supported by a bearing-type carrier member 48 which is slideable along a sliding rail 49, and a carrier member 50 having a hole with a female screw which is engaged with a screw shaft 51. Screw shaft 51 is rotatably supported by bearings 52 and 53 mounted on common frame 45 and has a gear 54 engaged with a gear 55 on motor shaft 56 of motor 57, thus forming a driving mechanism for optical read head 46. Similarly disposed horizontally on the other end of the same common frame 45 is optical unit 44 that comprises an optical read head 58 with a lens system 59, support bearings 60 and 61, a bearing-type carrier member 62, a carrier member 63 with female screw, a gear 64 on a screw shaft 65, a gear 66 on a motor shaft 67 of a motor 68, thus forming a driving mechanism for optical read head 58. Optical read heads 46 and 58 are to the best extent arranged to have travelling paths falling onto the same imaginary travelling plane (not shown) parallel to the disc surface. Upon receiving power signals from microprocessors (not shown), motors 57 and 68 independently and simultaneously move optical read heads 46 and 58 to predetermined positions in a radial direction of disc 27 for simultaneously

10

reproducing information from two separate disc positions of information-stored area 69 on the same surface of disc 27.

In order to perform the abovementioned multitasking, motor 39 and thus disc 27 are rotated at a constant angular velocity (CAV). Even though being reduced to half, the storage capacity of a compact disc employing the CAV method remains enormous, for instance, an 120-mm optical disc can still hold a minimum of 250 megabytes of data. Most importantly, the CAV rotation method allows the apparatus of the present invention to rotate at a constant, higher angular velocity for multitaskingly performing high-speed information reproduction.

Referring now to FIGS. 3-7, another embodiment of the present invention will be described in detail hereinafter.

FIG. 3 is a perspective, partial-cutaway view of a multitasking information processing apparatus 70 in accordance with the present invention, showing a front disc compartment 71 and a rear disc compartment 72 loaded with multisized discs, a pair of disc-compartment transporting means 73 for compartments 71 and 72 retractable into and out of a playhousing 74, and various control means on a front panel 75. Note that for simplification of illustration neither the disc-compartment transporting means on the other side of multitasking information processing apparatus 70 nor optical units are shown in FIG. 3. The pair of disc-compartment transporting means 73 not only allows both disc compartments to extend out of and retract into playhousing 74 but also enables front disc compartment 71 currently containing a single 120-mm optical disc to be independently extended to a disc loading/unloading position without disturbing the information reproduction being performed in rear disc compartment 72. As shown in FIG. 3, seven smaller optical discs with 45 mm in diameter are horizontally spaced in rear disc compartment 72. In the front panel 75 of multitasking information processing apparatus 70, there are a push-type button 77 for the open/close operation of front disc compartment 71, a turn-type button 78 for the open/close operation of both compartments 71 and 72, a microphone connector 79 for sound output to an earphone or speakers (not shown), and a volume controller 80 for adjustment of sound level. Also equipped in apparatus 70 is multitasking information processing apparatus 70 is a lockout device 76 for locking disc compartments 71 and 72 and thus for safeguarding the optical discs stored therein from being unauthorizedly removed. In addition to a mechanical key, the lockout device 76 is responsive to an electrical signal issued by a host computer, so that it allows the open/close operation of disc compartments controlled from the input of the keyboard of a host computer (not shown).

A partial cutaway view of a underside of the subchassis traverse driving mechanism 81 taken along the line 4-3 of FIG. 3 is shown in FIG. 4. A servo motor 82 fixed to the subchassis of front disc compartment 71 has a transverse rubber-roller 83 that tightly contacts the chassis of playhousing 74. Upon rotating, transverse rubber-roller 83 thus moves front disc compartment 71 through disc-compartment transporting means 73 to a disc loading/unloading position or a disc playing position. Rear disc compartment 72 is similarly moved by a servo motor 84 with a transverse rubber-roller 85. In order to enable both disc compartments to perform simultaneous close/open operation, the rear end of front disc compartment 71 is provided with a protruding part 86 having a center hole and the front end of rear disc compartment 72 is furnished with a protruding part 87 having also a center hole. Both center holes are aligned so as to allow the fastening/unfastening operation of latch 88 controlled by solenoid 89.

5,748,575

11

The exploded perspective view of disc-compartment transporting means 73 of FIG. 3 is detailed in FIG. 5. Playhousing 74 is made to have narrow openings 90 and 91 that form supporting rails 92 and 93 respectively. Supporting rails 92 and 93 having bearings 94 and 95 respectively support a suspended sliding device 96 that has five guiding rails. The top and the bottom guiding rails 97 and 98 of suspended sliding device 96 have bearings 99 and 100 respectively. All together, these rails and bearings allow suspended sliding device 96 to perform sliding operation inbetween supporting rails 92 and 93. On suspended sliding device 96, guiding rail 101 has bearings 102 and 103 and guiding rail 104 has bearings 105 and 106, while guiding rail 107 has no bearing. Guiding rails 101 and 104 and their respective bearings form a gap accommodating a sliding rail 108 that is fastened only to front disc compartment 71. At the distal end of sliding rail 108, there exists a sliding roller 109 that extends to rear disc compartment 72. Thus, front disc compartment 71 can individually slide to a disc loading/unloading position. Fastened to rear disc compartment 72 is a sliding rail 110 with sliding rollers 111 and 112, which slide along the space formed by guiding rails 104 and 107. Because of the arrangement of suspended sliding device 96, rear disc compartment 72 can thus be fully opened into a disc loading/unloading position.

FIG. 6 is an illustrative top plan view of the multitasking information processing apparatus 70 seen in FIG. 3 with eight optical discs and six optical units. Situated in front disc compartment 71 are an 120-mm disc 113 horizontally disposed on turntable 134 and two optical units 121 and 122 that are able to independently and simultaneously move to any predetermined disc positions in radial directions with respect to disc 113 for multitaskingly reproducing information stored on the lower surface of disc 113. It is also possible that each optical unit 121 or 122 has an additional optical read head as the configuration to be shown in FIG. 15 for simultaneously reproducing information, if any, stored on the upper surface of optical disc 113.

In addition to the 120-mm disc, turntable 134 disposed within disc compartment 71 can be used to hold a disc with a smaller disc diameter. Turntable 134 is capable of rotating in a CLV or CAV scheme. For a CLV-recorded disc, only optical unit 121 is in operation; while optical unit 122 will be additionally in effect if the information of disc 113 is detected to be in a CAV-recorded scheme. Thus, either CAV-recorded or CLV-recorded discs can be scanned accordingly for information reproduction, while a CLV-recorded disc doubles its storage capacity, a CAV-recorded disc can be scanned in a high-speed, multitasking way.

Horizontally disposed in rear compartment 72 are seven 45-mm-diameter discs 114-120 respectively mounted on turntables 135-141 and four optical units 123-126 respectively comprising optical read heads 127-132. The disc-setting tables of turntables 136-141 are arranged in such a manner that discs 114-120 are horizontally aligned with each other, thus falling onto an imaginary disc plane (not shown). Optical read heads 129-132 are also aligned to the best extent, forming a horizontal travelling plane (consisting of the broken circular lines) underneath and parallel to the imaginary disc plane for facilitating their focusing during retrieving the information stored on the lower surfaces of discs 114-120.

While FIG. 6 shows a configuration in which optical read heads 127-132 are all arranged to face the lower surfaces of discs 113-120, it is possible that some of the optical units 121-126 and thus their respective optical read heads 127-132 could be arranged to face the upper surfaces of

12

discs 113-120 so as to provide capability for retrieving information stored on the lower and the upper surfaces of these discs.

Turntable 137 and disc 116 are normally rotated in the CAV method by a turntable motor 722 that also drives the other six turntables and thus discs to rotate in the CAV method. As illustrated by the broken circular lines, each of optical units 123-126 is able to travel horizontally to an optical disc selected between discs 114-116, between discs 116-118, between discs 116, 119 and 120, and between discs 118 and 119, respectively, for information reproduction. Information stored on the 45-mm discs is preferably in the CAV scheme, in order for optical units 123-126 to perform high-speed, multitasking information reproduction. A single side of a 45-mm disc of this type is capable of holding a minimum of 60 megabytes of data, sufficient for storing a package of executable software programs such as a combination of Microsoft Word® Version 6.0a (about 17 megabytes), Microsoft Excel® Version 5.0 (about 17 megabytes), and Microsoft PowerPoint® Version 4.0 (about 18 megabytes). Use of a 45-mm disc or other small-sized discs is also more realistic than that of an 120-mm disc because software developers such as Microsoft®, WordPerfect®, or Lotus® are most likely to produce their own software discs but each of core software programs is not big enough to even fill up 15% of an 120-mm disc capacity. This also gives a user flexibility to choose a preferred program, for instance, a word processing program between WordPerfect® Version 6.0a (about 28 megabytes) and Microsoft Word®, since both are unlikely to be stored on the same disc.

As shown in FIG. 6, disc 116 is capable of being simultaneously scanned by three optical units 123-125. This allows three executable software programs, for instance, Microsoft Word®, Excel®, and PowerPoint®, to be simultaneously executed. Disc 118 that can be scanned by optical units 124 and 126 is an ideal location for storing a Microsoft Windows® 95 disc containing a disk operating system (DOS) and other shared programs. While running executable programs from discs situated in rear disc compartment 72, a user can enjoy digital music by playing a disc situated in front disc compartment 71. The individual open/close operation capability of front disc compartment 71 through disc-compartment transporting means 73 (shown in FIG. 5) further allows a user to change a music disc, when needed, without interrupting his/her active programs that are based on the information reproduction of the discs situated in rear disc compartment 72.

FIG. 7 is a block diagram of a control system of the multitasking information processing apparatus of FIG. 6. Basically, each of optical units 121-126 seen in FIG. 6 comprises a respective one of optical read heads (i.e., pickups) 127-132 and a separate driving means 705. Each of optical units 121-126 is interfaced with a separate signal amplifier 701, a separate servo system 704, and a separate signal-processing system. Each servo system 704 comprises several servo controls that separately control a separate driving means 705 for radial tracking of a respective one of optical read heads 127-132 as well as the focusing of said respective one of optical read heads 127-132. Each signal-processing system comprises a separate CIRC (Cross Interleaved Reed-Solomon Code) decoder 706, a separate CD-ROM decoder 707, and a separate RAM (random access memory) 708. In essence, each optical read head is capable of being independently moved by a separate driving means controlled through a separate servo system to a predetermined disc position of an optical disc selected from discs

5,748,575

13

113-120 and being independently focused thereat for retrieving information stored thereon.

Signals sensed by each of optical read heads 127-132 are very weak and thus amplified by their respective signal amplifier 701 to derive usable error signals and high-frequency signals. The derived error signals interface with respective servo system 704 to control focusing and radial tracking of the respective one of optical read heads 127-132. CLV/CAV controls 702 and 703 that also receive the derived error signals through a high-speed system control bus 716 are used to respectively control the rotation speeds of turntable motors 721 and 722 at a constant linear velocity (CLV) scheme when either of optical read heads 127-132 senses CLV-recorded information from discs 113-120. The high-frequency signals derived from each of optical read heads 127-132 are in a compact disc format or specifically in the EFM (eight-to-fourteen modulation) format and thus need to be processed by a signal-process system comprising CIRC (Cross Interleaved Reed-Solomon Code) decoder 706, CD-ROM decoder 707, and RAM (random access memory) 708 in order for the signals to be deinterleaved, demodulated, and decoded for error-correction process, restoring the original sequence of data symbols, and finally converting the 14-bit word back to the original 8-bit data symbol. RAMs 708 are used in temporarily storing data for reassembling during the signal processing proceeded in the respective signal-process system. A digital-to-analog converter (D/A C) 710 and audio amplifier 711, which are only necessary when discs have audio tracks, are shared by optical units 121-126 for discs 113-120.

In order for multitasking to take place most effectively, disc 116 disposed on turntable 137 is normally rotated in the CAV method by turntable motor 722 that also provides the same rotation speed for turntables 135, 136, and 138-141. Optical read heads 129, 130, 131, and 132 are able to travel through controlled swiveling by respective driving means 705 to positions proximate the lower surface of an optical disc selected between discs 114-116, between discs 116-118, between discs 116, 119 and 120, and between discs 118 and 119, respectively, for simultaneously retrieving a plurality of information sets stored thereon. This allows the total number of optical units and thus optical read heads to be less than that of turntables, thus not only reducing production costs but still providing high-efficiency and multitasking capability to the information retrieving operation performed on the same disc and/or different discs.

Also provided in FIG. 7 are (1) a plurality of control means comprising microprocessors (MPUs) 712-714, a ROM/RAM (read only memory and random access memory) 715, and (2) data transmitting means comprising a high-speed system control bus 716, ITDM (intelligent time-division multiplexer) 717, wide-band host interface bus 718, and ROM/RAM (read only memory and random access memory) 719. Each of the buses is a collection of multiple lines forming control bus, address bus, and data bus for carrying module-to-module communications. Multitasking capability of said control means and said data transmitting means is necessary in order for a plurality of sets of information to be simultaneously handled and transmitted to a host computer 720. MPUs 712 and 713 that share ROM/RAM 715 issue commands or control signals to CIRC decoders 706 and CD-ROM decoders 707 in a parallel manner through high-speed system control bus 716. The read only memory portion of ROM/RAM 715 contains basic instructions needed for MPUs 712 and 713 to issue a plurality of control signals to a plurality of servo systems 704 and a plurality of driving means 705 so as to indepen-

14

ently and simultaneously move optical read heads 127-132 to a plurality of predetermined disc positions located either on the lower surface of one disc or on the lower surfaces of several discs for multitaskingly reproducing a plurality of information sets constituting either a program or several programs stored thereon. The random access memory portion of ROM/RAM 715 is used for temporarily storing the instructions issued from host computer 720 served as the input of MPUs 712 and 713 for controlling the travelling motions of optical read heads 127-132.

After being deinterleaved, demodulated, and decoded by CIRC decoders 706 and CD-ROM decoders 707, the plurality of information sets retrieved from optical read heads 127-132 are converted back to the original 8-bit data symbol. The plurality of converted information sets are multiplexed by ITDM 717 in order to be simultaneously transferred to host computer 720 through wide-band host interface bus 718 that is interfaced with microprocessor 714, and ROM/RAM 719. Microprocessor 714 with multitasking capability controls the simultaneous transmitting of the multiplexed information to host computer 720. The read only memory portion of ROM/RAM 719 contains basic instructions defining how MPUs 712 and 713 should work coordinately and simultaneously together to issue commands to optical units 121-126 in order for a plurality of them to efficiently, multitaskingly, and simultaneously retrieve a plurality of information sets constituting one program or several programs stored on one disc or separately on plural discs. The random access memory portion of ROM/RAM 719 is used as buffer memory storage for temporarily storing the information to be transmitted when host computer 720 is tied up with other operations. When ready, the host computer 720 can accept the information temporarily stored in ROM/RAM 719 in bursts according to the instruction of MPU 714. While three microprocessors 712-714 are shown in FIG. 7 for controlling the reproducing and transmitting of information, it is possible that more microprocessors can be utilized or these microprocessors are replaced by a single high-performance multitasking microprocessor having a full 32-bit architecture with 32-bit address and data bus systems or better. Similarly, a less proportion of shared electronics such as digital-to-analog converter 710 and audio amplifier 711 are possible, as are other electronic configurations.

Owing to the high-speed and multitasking nature of the information processing apparatus 1 of the present invention, it becomes practical to execute programs directly from optical discs. This eliminates the conventional, tedious and time-consuming software installation procedure in which a software program stored on a plurality of floppy disks or an optical disc has to be (decompressedly) copied to a hard-disk drive of a computer from where the software program is then executed. This advantage is described in detail using the exemplary configuration of FIGS. 6 and 7 in which presumably disc 116 contains a package of Microsoft® software programs including Microsoft Word®, Excel®, and PowerPoint® and disc 118 is a Microsoft Windows® 95 disc containing a disk operating system (DOS) program and other shared Windows files for the basic operation of host computer 720. After discs 116 and 118 are properly loaded, optical read heads 129-132 first recognize the existence of both discs and their corresponding programs in order to create a disc directory-structure file, which is similar to a file allocation table (FAT) created for monitoring the use of the sectors of a hard-disk drive, for storing the basic information of both discs such as disc locations and directory structures to the hard-disk drive of host computer 720. The disc

5,748,575

15

directory-structure file is updated only if discs 116 and 118 are replaced by other or newer discs are added to other empty turntables. There is essentially no software installation as manually needed in the conventional practice. Software programs can be written in such a way as to automatically create or modify (1) a user definable boot file (such as autoexec.bat) on a hard-disk drive in order to quickly direct the host computer 720 to the locations of the software programs contained in discs 116 and 118, and (2) a working directory on the hard-disk drive of host computer 720 for storing resulting files that will be created or changed during the execution of the programs.

Because none of the program files on the optical disc is copied to the hard-disk drive, the approach of the present invention essentially eliminates software installation, therefore alleviating the heavy burden of a hard-disk drive in information reproduction. Note that according to the conventional practice both software programs and resulting/working files are mixedly stored on a hard-disk drive for during the routine operation of a computer. Accordingly, the present invention provides two additional advantages: (1) eliminating the need to demand a high-capacity hard-disk drive for storing program files that will never be altered throughout the entire life of their usage, and (2) eliminating time-consuming hard-disk drive maintenance that involves file defragmentation in order for a hard-disk drive to regain its performance.

Further, the capability of launching a program directly from an optical disc loaded in the information processing apparatus 1 of the present invention eliminates the need for an end user to make a set of backup copies (on floppy disks) for a purchased software program and thus a software developer can make its CD-version products not executable from a hard-disk drive, accordingly minimizing illegal-copying of a software program. This can be simply based on, for instance, the difference in recording formats between the optical disc and the hard-disk drive. A software developer can embed a key code in the EFM format onto an optical disc containing the program to be copy-right protected. Without detecting the presence of the embedded key code in the EFM format, a computer will not execute the program. This in effect disables the program to be executed from a hard-disk drive, and thus completely prevents spreading of a software program. This type of software program can be considered to be a hardware type in nature, because its copy-right protection is not relied on the conventional practice of using a sealed envelope. As software manufacturers are well protected, consumers can be afforded their opportunity to really try out a fully-working version of a software program before deciding whether to keep it or not.

During the process of booting, host computer 720 in accordance with the booting instruction of a user defined boot file (e.g., autoexec.bat) created on the hard-disk drive interfaces through wide-band host interface bus 718 with MPU 714 that determines and issues the most efficient instructions to MPUs 712 and 713 in order for them to provide power signals to respective servo systems 704 and respective driving means 705 so as to move optical read heads 130 and 132 to disc 118 for simultaneously reproducing the disk operating system (DOS) information and Microsoft Window® 95 information. It is preferred that ROM/RAM 715 stores a set of predefined instructions; and, software programs stored on the disc are written and arranged in a particular manner so that optical read head 130 is controlled to move specifically to a predetermined position selected from a set of disc tracks that contain sound information and/or other non-video files while optical read

16

head 132 is instructed to move specifically to another predetermined position selected from another set of disc tracks that contain video information and/or other non-sound files. In other words, optical read head 130 is controlled for producing sound effects and other non-video files while optical read head 132 is instructed mainly to produce video images and other non-sound files. Controlled by data transmitting signals issued by microprocessor 714, video images can be transmitted in bursts through wideband host interface bus 718 directly to a video circuit (not shown) of host computer 720. With this scheme, reproduction of video images and sound effects can be simultaneous, thus allowing a program to be executed at a much higher speed and arriving at a ready-to-run state in no time.

In contrast, in accordance with conventional practice, the proceeding of a Windows-based software program is inevitably interrupted constantly, especially when video information and sound information are too large to be read within a reasonable time period.

Disc 116 loaded on turntable 137 can be simultaneously accessed by three optical read heads 129-131. Accordingly, an information processing apparatus of this type will hardwarely allow a user to simultaneously execute three different programs at the same time. Front disc compartment 71 seen in FIG. 6 has its own turntable 134, optical units 121 and 122, CLV/CAV control 702 and turntable motor 721 (both shown in FIG. 7) for rotating and scanning an 120-mm CD at either the CLV or the CAV method; thus, an audio CD can be simultaneously played while a user is executing the software programs stored on the discs disposed in rear disc compartment 72.

Shown in FIG. 8 is an information processing apparatus 800 with an alternative configuration of disc-storage locations and optical units, having a rear disc compartment 801 different from FIG. 6. The rear disc compartment 801 of FIG. 8 bears six discs 802-807 and six optical units 808-813. In accordance with this embodiment, at least, discs 802 and 803, discs 804 and 805, and discs 806 and 807 are respectively aligned with each other. Further, each of optical units 808-813 is capable of linearly moving along a screw shaft 814 and a sliding rail 815 by a predetermined distance in a radial direction of a selected disc so as to allow each of respective optical read heads 816-821 to be correspondingly positioned on a predetermined disc position for retrieving information stored thereon. Thus, each of discs 802-807 can be scanned either by one optical read head or by two optical read heads simultaneously for information reproduction.

FIGS. 9A and 9B are perspective top and cutaway side (along the line 9B-9B) views respectively of the turntable showing a disc-setting table and a disc-holding and -releasing means having a self-clamping and -releasing mechanism for detachably holding an optical disc thereon in accordance with the present invention. The disc-holding and -releasing means and thus the self-clamping and -releasing mechanism of the turntable herein are characterized by miniaturization and are designed to facilitate disc loading/unloading operation. In the following, exemplary illustration is given to turntable 135 and disc 114 disposed thereon as seen in FIG. 6. To facilitate illustration, only FIG. 9B is loaded with disc 114. Turntable 135 basically comprises a disc-setting table 150 for horizontally bearing a disc thereon and an elevated center portion 151 which is sized to fit into the center hole of optical disc 114 as shown in FIG. 9B. Elevated center portion 151 comprises a hollow member 152 being in a cylindrical shape wherein a spring device having a flat bottom 153 and four strip ends 154 is situated on the top of spring 155 that provides up-and-down motion through

5,748,575

17

a guiding ring 156. During disc loading, spring strip ends 154 are forced to retract through four openings 157 to the inside of hollow member 152 and then returns to their outward-biased normal position that also provides a slightly downward force so as to hold disc 114 in place as shown in FIG. 9B. Also in the elevated center portion 151 is a release mechanism having a pressing button portion 158 and a release bottom portion 159. Pressing button portion 158 is confined in the inside of hollow member 152 by means of the circular edge 160 of hollow member 152. When pressing button portion 158 is pushed by a user's finger for disc unloading, release bottom portion 159 and thus flat bottom 153 are accordingly moved downward to cause the retraction of spring strip ends 154 into the inside of hollow member 152, thus releasing disc 114. To obtain self-releasing function, disc-setting table 150 is made to comprise disc-releasing springs having one end held by the rectangular slots 161 and the other end 162 biased upward but capable of being pushed downward when disc 114 is held in place by spring strip ends 154.

Hollow member 152 may optionally have a noncircular outer boundary such as having a locking portion 163 for adapting an optical disc having a center hole with a complementary boundary or shape so as to ensure precision gripping, thus allowing disc 114 to rotate at a speed much higher than the conventional practice.

FIG. 10 is an enlarged perspective top view of optical unit 124 and three adjacent discs 116-118 which are arranged in the same configuration as seen in FIG. 6, illustrating that a single driving means (or swing mechanism) is used to horizontally move an optical read head selectively between various disc positions as well as between a plurality of discs for information reproduction in accordance with the present invention. Information starting from disc directory structures is stored from each innermost track 164 to the outermost edge of discs 116-118. Located at the distal end of optical unit 124 is an optical read head 130 that is currently positioned at the innermost track 164 of disc 118. Optical read head 130 is able to swing about axis 166 that is rotatably supported by bearing 191 and supporting frame 222 attached to driving means 168, in accordance with a broken circular line or travelling path 167. The swing motion of optical read head 130 is powered by the driving means (or swing mechanism) 168 through a toothed belt 169. Discs 116-118 are horizontally aligned with each other so as to facilitate the focusing action of optical read head 130 to each of the discs, and are concentric with respect to axis 166 so that the innermost tracks of the three discs are reachable as indicated by the broken circular line 167. Thus, by spinning these discs and by swinging optical read head 130 about axis 166, information stored on any tracks of discs 116-118 becomes readily reproducible.

FIG. 11 is a cutaway view, showing turntable 139 on which disc 118 is horizontally disposed and optical unit 124 that comprises optical read head 130 and driving means (or swing mechanism) 168 for providing a necessary force to horizontally swing optical read head 130 to a preselected position. Turntable 139 has a turntable shaft 213 which is rotatably supported by bearings 214 and 215 that are attached to a supporting frame 216 fastened to the bottom frame 224 of compartment 72. At the bottom portion of turntable shaft 213 are pulleys 217 and 218 that are connected respectively by toothed belts 219 and 220 for transmitting rotation power from turntable motor 722 seen in FIG. 7 and to other turntables. Under these circumstances, a plurality of turntables can be driven by a single turntable motor. This greatly reduces construction costs and space for

18

commercializing the optical information processing apparatus of the present invention.

Optical read head 130 situated in an optical-read-head housing 221 comprises a semiconductor laser diode 170, a lens system 171, photosensors 172 and 173, and a focusing mechanism 174 situated on the distal end of optical-read-head housing 221. As detailed in FIG. 12, semiconductor laser diode 170 is a light source for producing a laser beam. The laser beam emitted from laser diode 170 is converted by a collimator 175 to a parallel light beam 176 that is bent at an angle of 90° by means of a mirror 177 and is then focused by the focusing mechanism 174 onto the information-stored surface layer 178 of disc 118. A beam of light reflected from the information-stored surface layer 178 is deflected at an angle of 90° C. by mirror 177 and is then condensed through a quarter-wavelength ($\lambda/4$) plate 179, polarizing beam-splitting prisms 180 and 181, and the lens 182 to the photosensor 172 that reads the change of the output signals.

Focusing mechanism 174 detailed in FIG. 12 comprises an objective lens 184 attached to a vertically movable device 185, tension springs 187, and a focus-tracking coil 188 wound around a stationary bobbin 189. Vertically movable device 185 has a ring-type magnet 186 fixedly situated therein. Tension springs 187 provide tension and keep objective lens 184 straight in the focusing mechanism 174 as objective lens 184 vertically moves. Projection lens 183 and photosensor 171 are arranged in a direction of the beam that is reflected from disc 118, bent by mirror 177, and condensed through $\lambda/4$ wave plate 179, polarizing beam-splitting prisms 180 and 181, thereby detecting a focusing error. In the focused condition, a zero error exists from photosensor 171. When an error signal produced from either a too-far or a too-close condition is detected by photosensor 171, the detected error signal is amplified and fed to focus-tracking coil 188 wound around stationary bobbin 189 which then produces a magnetic field to cause ring-type magnet 186 and thus objective lens 184 to move in the relevant direction until the error signal becomes zero and the beam is in focus.

As shown in FIG. 11, the other distal end of optical-read-head housing 221 is attached to a shaft 190 that is rotatably supported by bearings 191 and 192 and has a pivoted end 193 for its swinging. Bearings 191 and 192 are respectively supported by top and bottom supporting frames 222 and 223 fixedly attached to driving means 168. A stop pin 194 fixedly attached to the bottom frame 224 of rear disc compartment 72 and two helical tension springs 195 and 196 arranged in opposite direction are provided in order to produce torque restrain for a steady swing of shaft 190 about its axis 166. A stop pin 197 fixedly attached to the bottom portion of shaft 190 is provided for shaft 190 to rest at a reference position. Toothed belt 169 connects a pulley 198 on shaft 190 and a pulley 199 on moving-coil shaft 200 for transmitting rotation power. Pulley 199 has a diameter larger than pulley 198 so that driving means 168 can provide a maximal swing angle of 300 degrees. Supported by bearings 201, moving-coil shaft 200 has top and bottom pivots 202 and 203 that are respectively held in place by top and bottom frames 204 and 205 for its swing.

Driving means (or swing mechanism) 168 as seen in FIG. 11 is further detailed in FIG. 13 in a partial cutaway top view in which top frame 204 and supporting frame 222 (seen in FIG. 11) are removed. In accordance with the present invention, driving means 168 is able to provide a rotating force to horizontally swing optical read head 130 about axis 166 for a maximal swing angle of 300° as indicated by the broken circular line or travelling path 167. This allows

5,748,575

19

optical read head 130 to travel between various positions of a selected disc as well as between discs 116-118. Most importantly, the travelling of optical read head 130 between these discs is as rapid as that between various positions within the selected disc, because the travelling involves neither multidirectional nor three-dimension maneuver but needs only one single-directional movement.

In order to provide a rotating force, driving means 168 is arranged as shown in FIGS. 11 and 13, in which one end of a moving coil 206 is fixedly attached to moving-coil shaft 200, the other end is allowed to freely travel in a uniform air gap 207 defined by an outer soft-iron pole piece 208 and inner pole piece 209. Bonded to outer soft-iron pole piece 208 is a magnet 210. An air gap 211 extending to the inner area of covering frame 212 is provided in order for moving-coil shaft 200 with attached moving coil 206 to be assembled into the configuration of FIG. 13 and also allows moving-coil shaft 200 and the fixedly attached end of moving coil 206 to rotate about the axis defined by pivots 202 and 203 (FIG. 11). Attached to the outer circular area of magnet 210 is a laminated steel shell 213 that acts as a magnetic collector ring and also effectively shields the element from stray fields.

Illustrated in FIG. 14 is another preferred embodiment of the present invention, wherein information processing compartment 300 has an optical unit 301 comprising an optical read head 302 and a driving means (or swing mechanism) 303, wherein said driving means 303 enables said optical read head 302 to travel by swinging about axis 316 to any positions on discs 304-309 respectively mounted on turntables 310-315 for information reproduction. Each of these discs has a diameter of 45 mm. Within the compartment, these discs are horizontally and concentrically disposed at predetermined positions such that the disc centers are at an equal distance from the axis 316 of optical unit 301. Underneath turntable 310 is a turntable motor (not shown) which is also used to drive turntables 231-315 simultaneously. Each of turntables 310-315 comprises its own disc-loading and releasing means with self-clamping and -releasing feature so that once being loaded onto turntables 310-315, discs 304-309 will remain being clamped at any time and can be rotated simultaneously. Thus, without going through other intermediate loading stages (such as internal disc changing or selecting used in the prior art), information reproduction can be effectively performed by simply moving optical read head 302 to a disc selected between discs 304-309 disposed within the same compartment. This eliminates any need to equip an information processing apparatus with a disc-turntable rotating mechanism, a disc transporting means, or other disc changers described in prior arts such as U.S. Pat. Nos. 5,119,354, 5,146,451, 5,193,079, and 5,334,218.

Driving means 303 enables optical unit 301 to perform a maximum of 350° swing about axis 316, starting from position 318, for accessing selectively between disc tracks and discs 304-309. In essence, optical read head 302 of optical unit 301 travels in accordance with the broken circular line 317; thus, any information stored on these discs becomes readily accessible. Because of being designed for discs with smaller sizes and being equipped with a single turntable motor and a shared optical unit 301, compartment 300 can be economically produced in a size similar to the commercially available single 120-mm-disc player, for being installed into the interior of a personal computer.

Apparatus 300 is optionally equipped with a servo control (not shown), which enables the turntable motor to rotate at a constant linear velocity (CLV) in addition to at a constant angular velocity (CAV). Use of the CLV-recording method

20

doubles the storage capacity of the 45-mm disc to 120 megabytes from 60 megabytes compared with use of the CAV-recording method. This is advantageous for a software developer to fit a lengthy program or several programs as a package into a single small-sized disc. On the other hand, if information to be stored in a 45-mm disc is less than 60 megabytes, the CAV method is preferred in order to allow information reproduction to be performed at a higher speed.

In a further preferred embodiment of the present invention, discs 304-309 shown in FIG. 14 are arranged in a manner so that there is an open space between disc 304 and disc 309 for optical unit 301 to park at position 318. This open space allows optical unit 301 of apparatus 300 to further comprise an upper optical read head 320 in addition to lower optical read head 321 as shown in FIG. 15, without causing any inconvenience to disc loading/unloading operation. Upper and lower optical read heads 320 and 321 have configurations similar to the embodiments of optical read head 130 singularly situated in optical-read-head housing 221 hereinbefore detailed in FIG. 12. Optical-read-head housing 322 has a horizontal open slot 323 for an optical disc selected from discs 304-309 to insert therein so that the innermost tracks on both surfaces of the disc become simultaneously accessible to an objective lens 323 of upper optical read head 320 and to an objective lens 324 of lower optical read head 321. Note that objective lens 323 is disposed in a direction facing to objective lens 324, so as to face the other surface (i.e., the upper surface) of an optical disc selected from disc 304-309. The use of two optical read heads in an optical unit provides twofold advantages: doubling not only the information storage capacity of a disc but also the speed of information reproducing.

While preferred embodiments of the present invention have been shown and described herein, it will be understood that such embodiments are provided by way of example only. Numerous variations, changes, modification, and substitutions will occur to those skilled in the art without departing from the invention herein. Accordingly, it is intended that the invention be limited only by the spirit and scope of the appended claims.

What is claimed is:

1. An information processing apparatus with multitasking function, the information processing apparatus comprising:
 - (a) a plurality of turntables, each comprising a disc-setting table for mounting an optical disc;
 - (b) a plurality of optical units, each comprising a driving means and an optical read head, wherein said driving means is provided for moving said optical read head in a radial direction of said optical disc to a predetermined disc position on a surface of said optical disc;
 - (c) means for simultaneously controlling a plurality of said driving means to move a plurality of said optical read heads to a plurality of predetermined disc positions on at least two optical discs for retrieving information stored thereon;
 - (d) a plurality of signal-process systems for converting a plurality of information sets retrieved by said plurality of optical read heads from a compact disc format to the original state of the information; and
 - (e) data transmitting means for transmitting a plurality of the information sets converted by said plurality of signal-process systems to a host computer.
2. The information processing apparatus of claim 1, wherein at least one of said optical units further comprises an additional optical read head having an objective lens disposed in a direction facing the other surface of a selected

5,748,575

21

optical disc so that information stored on both surfaces of said selected optical disc can be simultaneously accessed.

3. The information processing apparatus of claim 1, wherein said plurality of turntables and said plurality of optical units are arranged in such a manner that at least two optical discs adjacently stored in said information processing apparatus are generally aligned with each other so that said at least two optical discs are selectively accessible by at least one of said optical read heads.

4. The information processing apparatus of claim 1, wherein a selected plurality of said optical read heads are generally aligned with each other so that at least two of said selected plurality of optical read heads are capable of being independently moved by separate driving means to at least two of predetermined disc positions on the same surface of a selected optical disc for simultaneously retrieving at least two sets of information stored thereon.

5. The information processing apparatus of claim 1, wherein;

said plurality of turntables are horizontally arranged in such a manner that a selected plurality of optical discs stored thereon are generally fallen onto an imaginary horizontal disc plane; and

said plurality of optical units are arranged in such a manner that the traveling paths of a selected plurality of said optical read heads are generally fallen onto two imaginary horizontal travelling planes, one above and the other below said imaginary horizontal disc plane;

so that said selected plurality of optical read heads are able to independently move to a selected plurality of predetermined disc tracks on both surfaces of at least one of said selected plurality of optical discs for simultaneously retrieving a plurality of information sets stored thereon.

6. The information processing apparatus of claim 1 further comprising at least one disc compartment for storing said plurality of turntables and said plurality of optical units therein, and a security means for locking said at least one disc compartment from being unauthorizedly opened so as to safeguard optical discs stored therein.

7. The information processing apparatus of claim 6, wherein said security means is selectively controllable by a mechanical means and by an electrical signal.

8. The information processing apparatus of claim 1 further comprising two disc compartments for storing said plurality of turntables, and a disc-compartment transporting means that enables one of said two disc compartments to independently extend out and retract into said information processing apparatus for disc exchanging while the other of said two disc compartments remains in a retracted position.

9. The information processing apparatus of claim 1 further comprising a turntable motor and a control means, wherein said control means is provided for controlling the rotating of said turntable motor selectively at a constant angular velocity and at a constant linear velocity.

10. The information processing apparatus of claim 1, wherein at least two of said optical read heads are moved by respective driving means for coordinately proceeding the reproduction of a software program, one of said at least two optical read heads is moved to a set of disc tracks consisting of the data that are not responsive to reproducing the sound effects of said software program, and another one of said at least two optical read heads is moved to another set of disc tracks consisting of the data that are not responsive to

22

reproducing the video images of said software program, so that said sound effects and said video images of said software program are simultaneously reproduced.

11. The information processing apparatus of claim 1, wherein each of said turntables comprising:

(a) a disc-setting table for bearing an optical disc thereon, said disc-setting table comprising disc-releasing means having an outward-biased tendency for pushing said optical disc apart from said disc-setting table; and

(b) a disc-holding and -releasing means comprising (i) a hollow member that has an elevated center portion being sized to fit into the center hole of said optical disc, (ii) disc-holding means retractable into the inside of said hollow member but preferably returning to its outward-biased normal position protruding to the outside of said hollow member for locking said optical disc in place, and (iii) a releasing button that upon pressing retracts said disc-holding means to the inside of said hollow member, so as to allow said disc-releasing means to push said optical disc apart from said disc-setting table.

12. The turntable of claim 11, wherein the elevated center portion of said hollow member has a noncircular outer boundary for adapting a disc having a center hole with a complementary boundary so as to ensure precision gripping, thus allowing said disc to rotate at a high speed.

13. An information processing apparatus comprising:

(a) a disc compartment;

(b) a plurality of turntables disposed within said disc compartment, each of said turntables comprising a disc-setting table for mounting an optical disc thereon;

(c) an optical unit comprising a driving means and at least one optical read head, said driving means being provided for moving said at least one optical read head in a radial direction relative to at least one of said disc-setting tables;

(d) means for controlling said driving means to move said at least one optical read head for selectively accessing optical discs mounted on at least two of said plurality of turntables; and

(e) at least one signal-process system for converting the information retrieved by said at least one optical read head from a compact disc format to the original state of the information;

wherein said turntables, said disc-setting tables, and said optical unit are arranged in such a manner that optical discs mounted on said disc-setting tables are generally aligned with each other so as to allow said optical unit to selectively access each of said optical discs.

14. The information processing apparatus of claim 13, wherein said optical unit comprises two optical read heads having respective objective lenses facing to each other so that said two optical read heads are capable of being moved simultaneously by said driving means for retrieving information stored on both surfaces of a selected optical disc thereon.

15. The information processing apparatus of claim 13 further comprising a turntable motor and a control means, wherein said control means is provided for controlling the rotating of said turntable motor selectively at a constant angular velocity and at a constant linear velocity.

* * * * *

FB



US006222799B1

(12) **United States Patent**
Lee

(10) **Patent No.:** US 6,222,799 B1
(45) **Date of Patent:** Apr. 24, 2001

(54) **HIGH-PERFORMANCE INFORMATION PROCESSING APPARATUS HAVING MULTITASKING FUNCTIONS**

5,631,893 * 5/1997 Kang et al. 369/34
5,666,334 * 9/1997 Tokuyama et al. 369/34
5,734,631 * 3/1998 Ikedo et al. 369/34

(75) **Inventor:** Howard Hong-Dough Lee, Bloomfield, MI (US)

* cited by examiner

(73) **Assignee:** Intellectual Science and Technology Inc., Bloomfield, MI (US)

Primary Examiner—Nabil Hindi

(74) *Attorney, Agent, or Firm*—Hartman and Hartman, P.C.

(*) **Notice:** Subject to any disclaimer, the term of this patent is extended or adjusted under 35 U.S.C. 154(b) by 0 days.

(57) **ABSTRACT**

An information processing apparatus having hardware components that include plural turntables, plural head units, plural decoding units, at least one encoding unit, and a system control unit. These components are adapted in such a manner as to afford (1) true multitasking in information reading and writing, (2) direct communication for information to be exchanged directly within the information processing apparatus, (3) disc removability for information to be stored as off-line archives and to become transportable between computer systems, (4) separation of user-created data from program files for eliminating time-consuming file-defragmentation processing and for conveniently safe-keeping the user-created data, and (5) capability of launching favored software programs directly from original software discs. In essence, the apparatus provides multiple and highly-improved functions of secondary and tertiary storage that cannot be obtained from any combinations of conventional hard-disk, floppy-disk, optical-disc, and backup drives.

(21) **Appl. No.:** 09/513,985

(22) **Filed:** Feb. 26, 2000

Related U.S. Application Data

(62) Division of application No. 08/850,844, filed on May 2, 1997, now abandoned.

(51) **Int. Cl.**⁷ G11B 7/22

(52) **U.S. Cl.** 369/34; 369/36

(58) **Field of Search** 369/30, 33, 34, 369/32, 58, 36

(56) **References Cited**

U.S. PATENT DOCUMENTS

5,574,881 * 11/1996 Yusuoka et al. 369/34

15 Claims, 10 Drawing Sheets

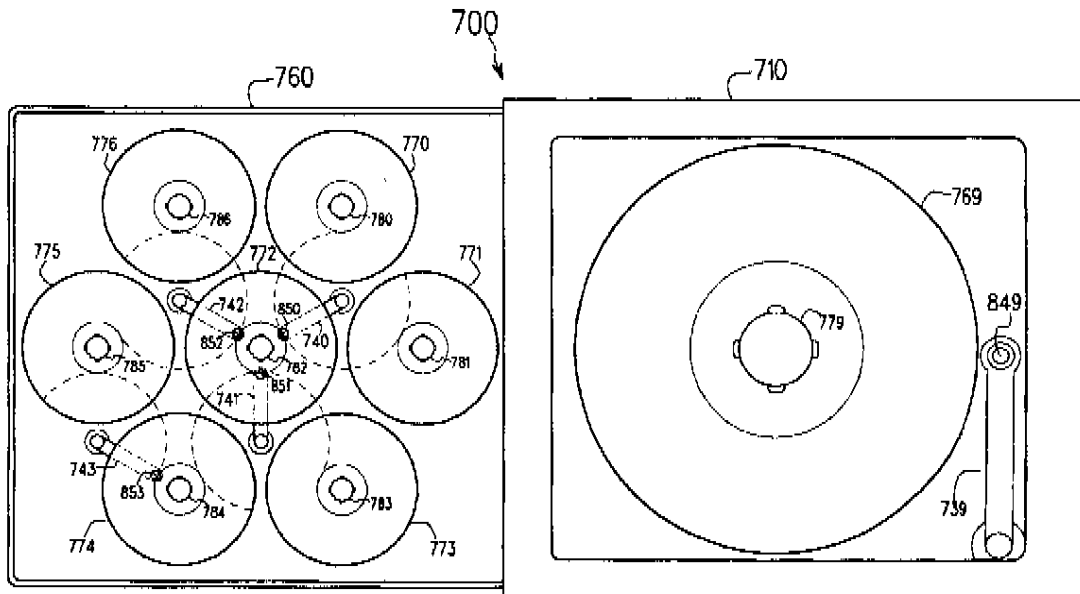

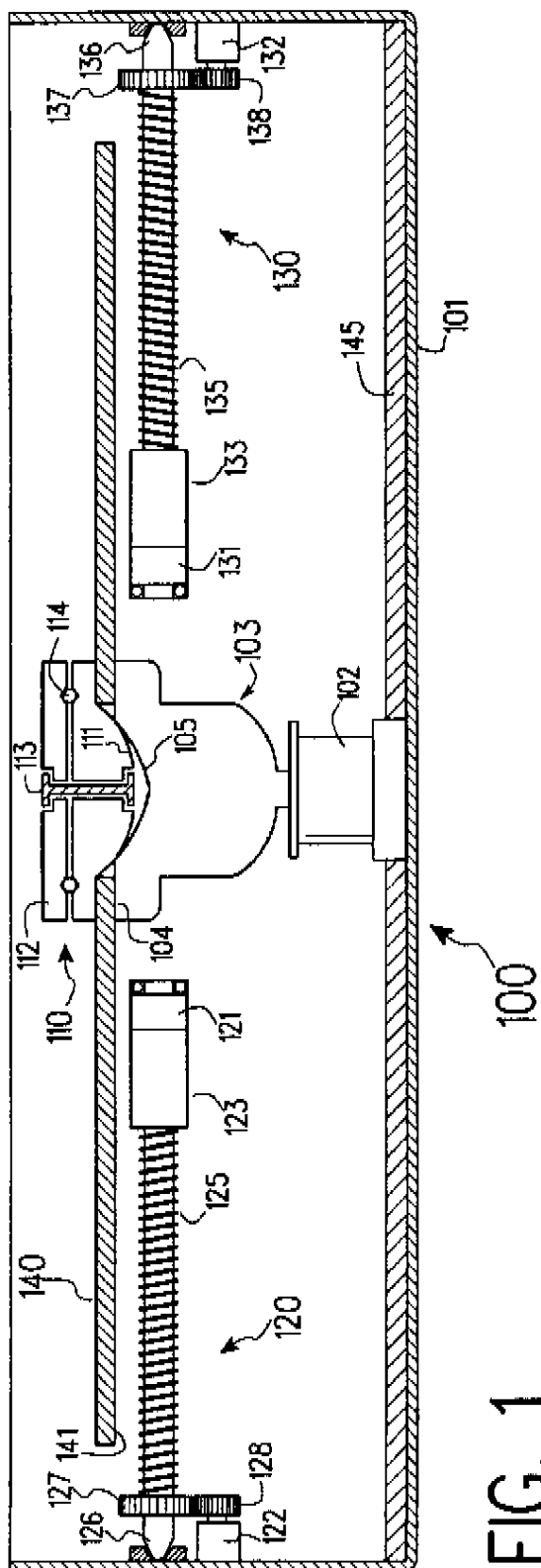

FIG. 1

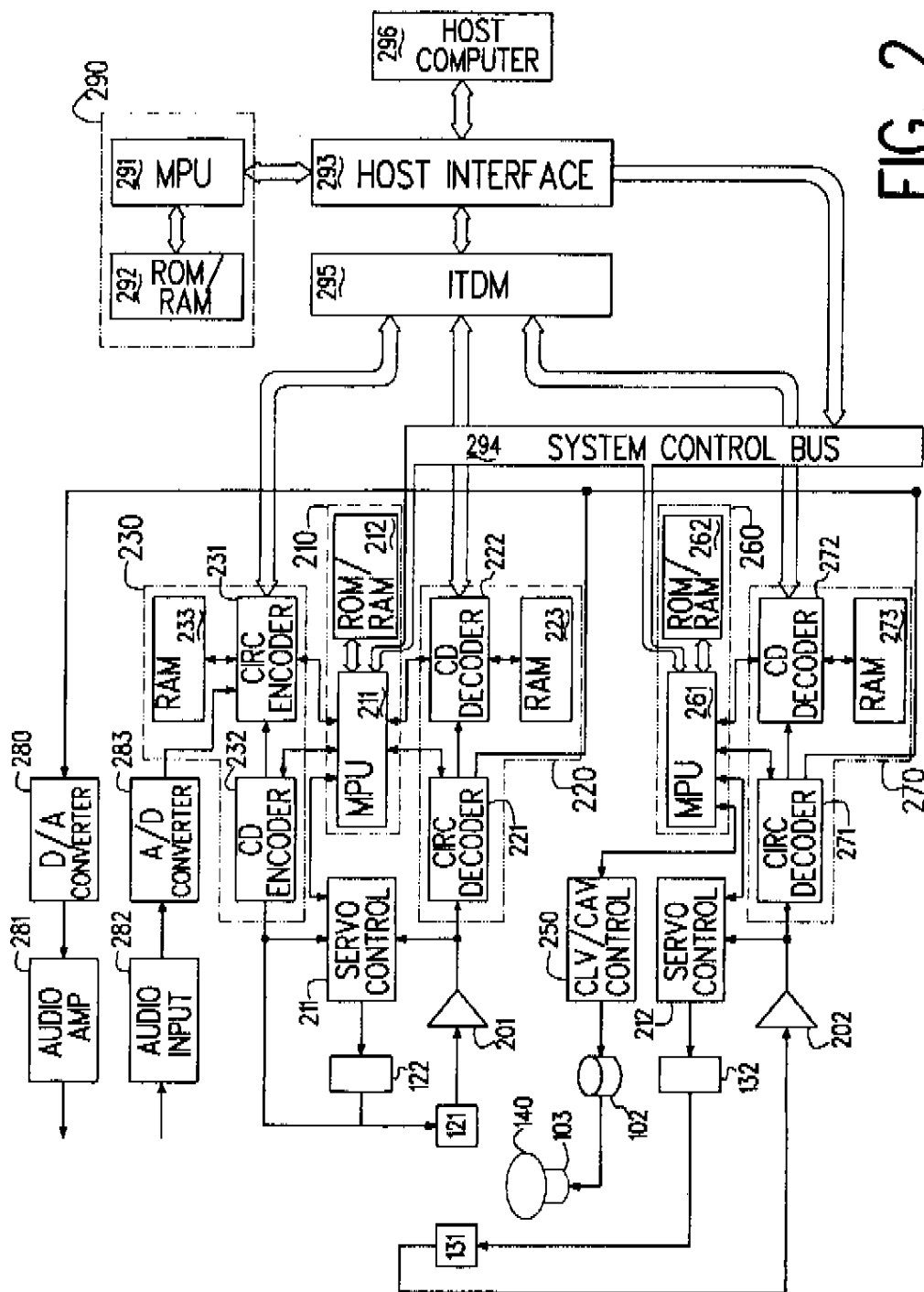

FIG. 2

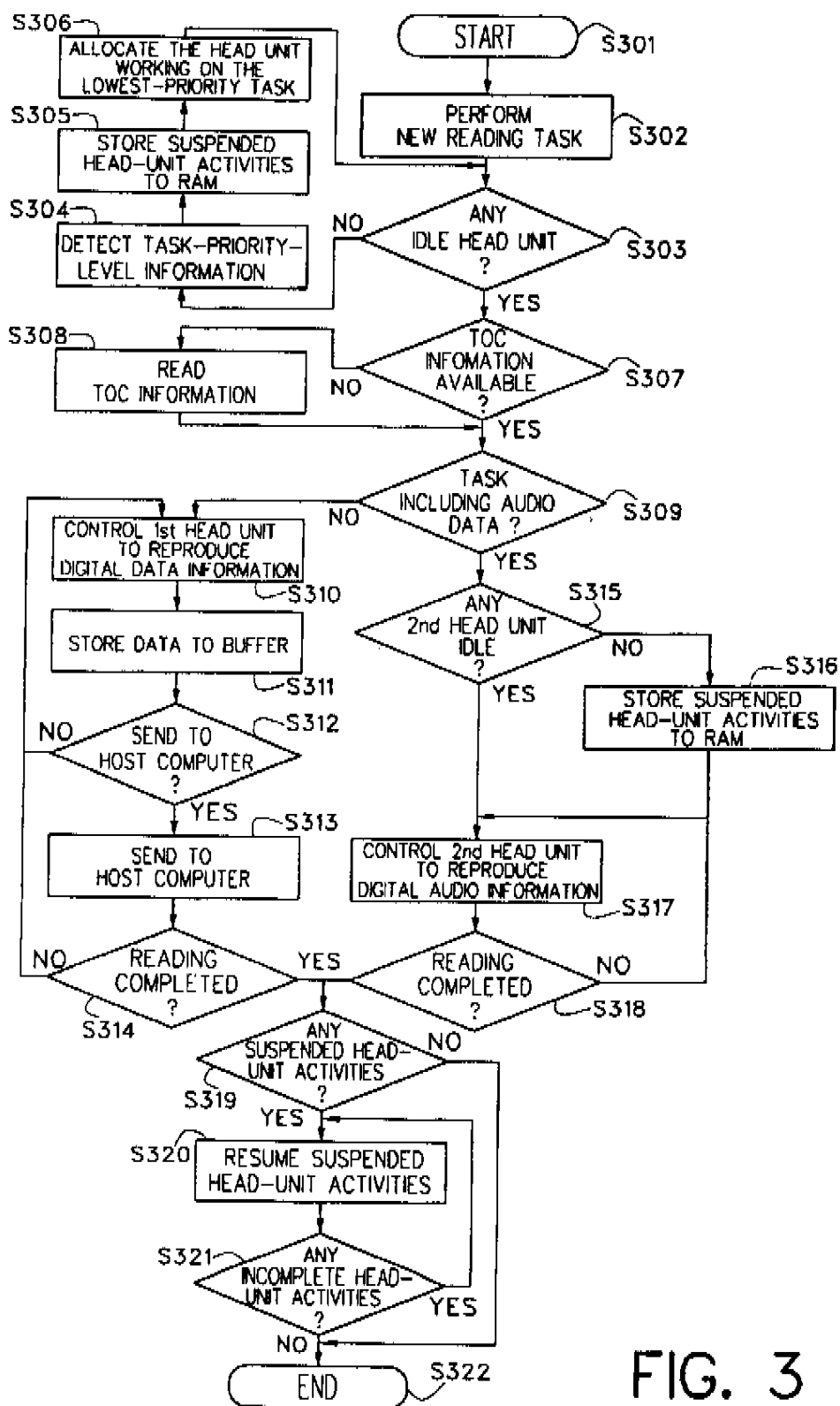
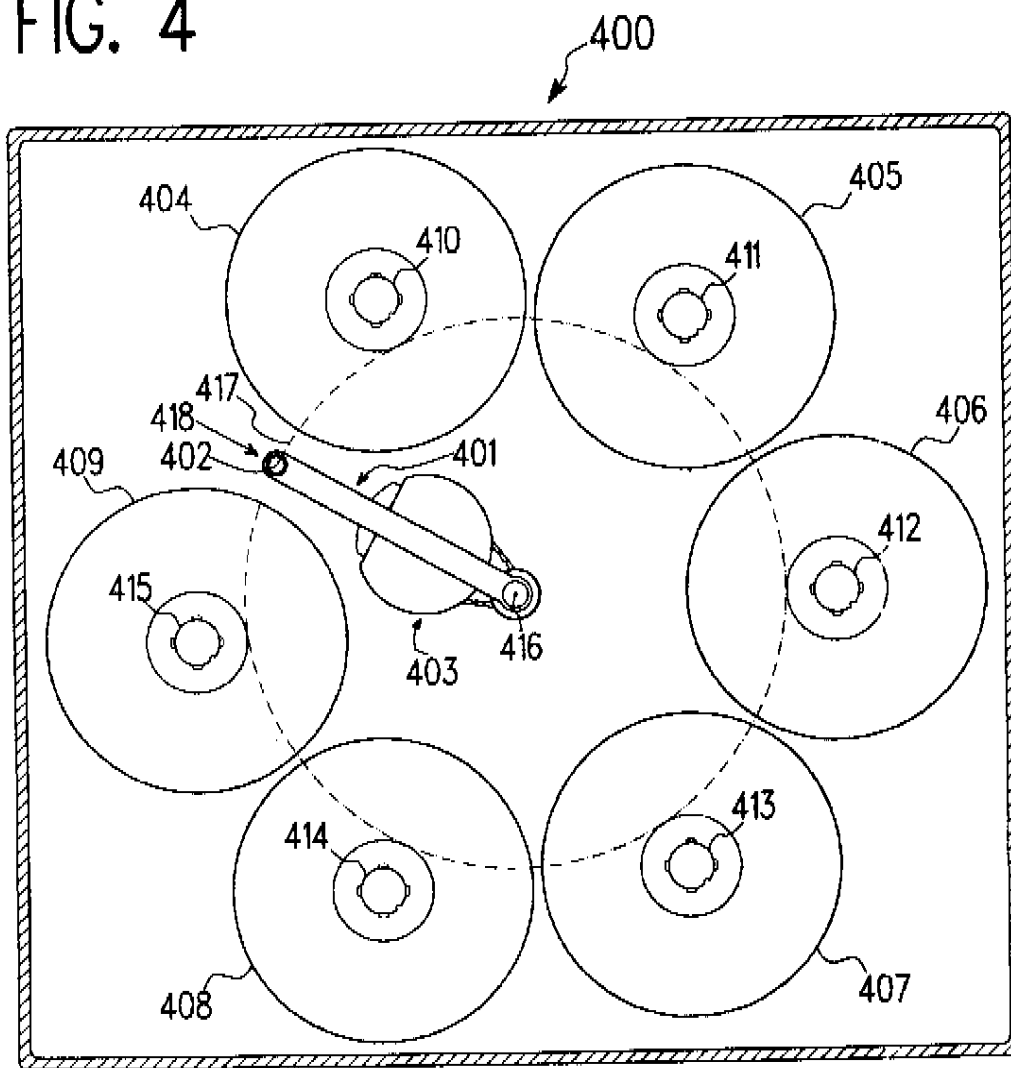

FIG. 3

FIG. 4



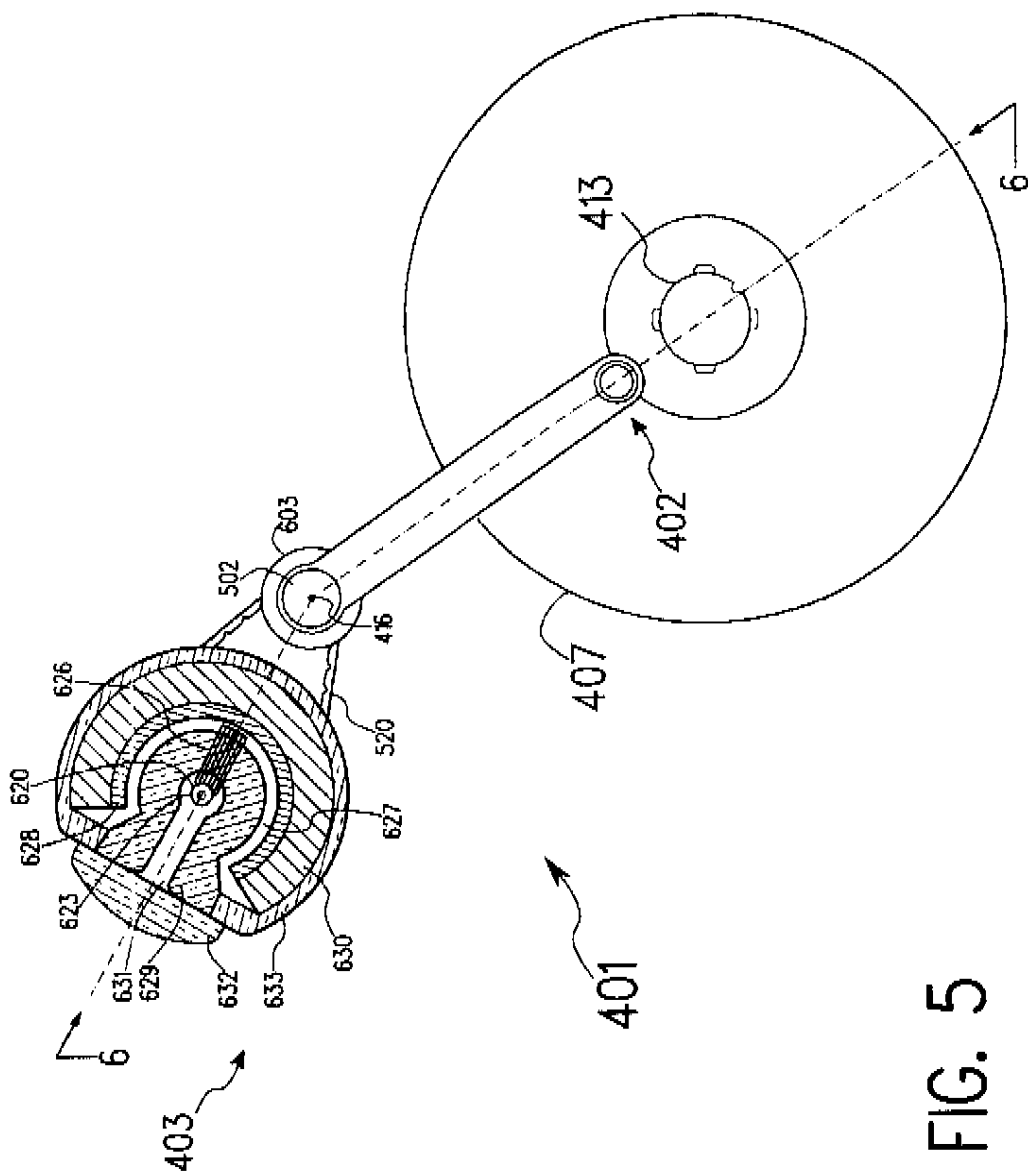

FIG. 5

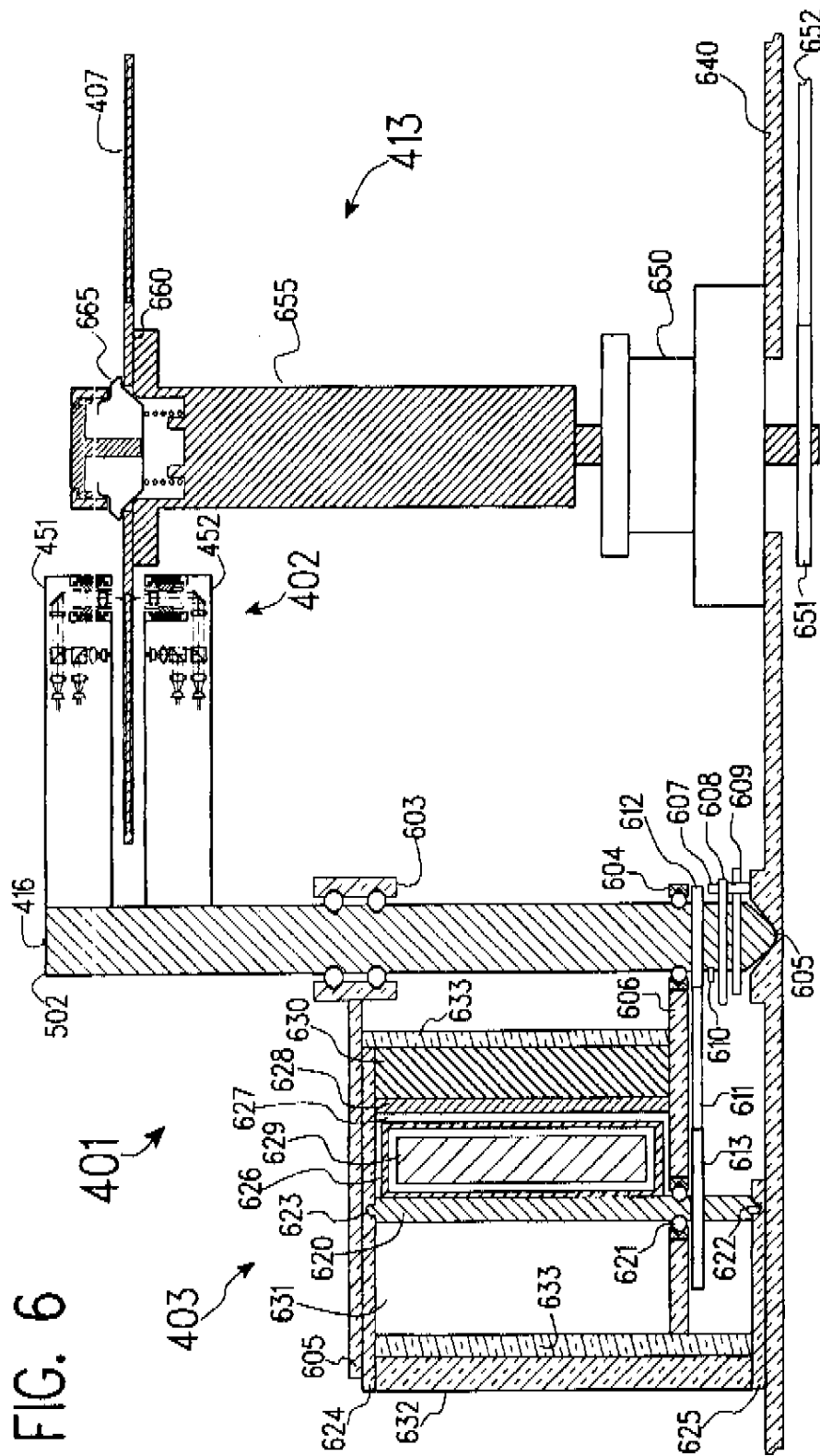

FIG. 6

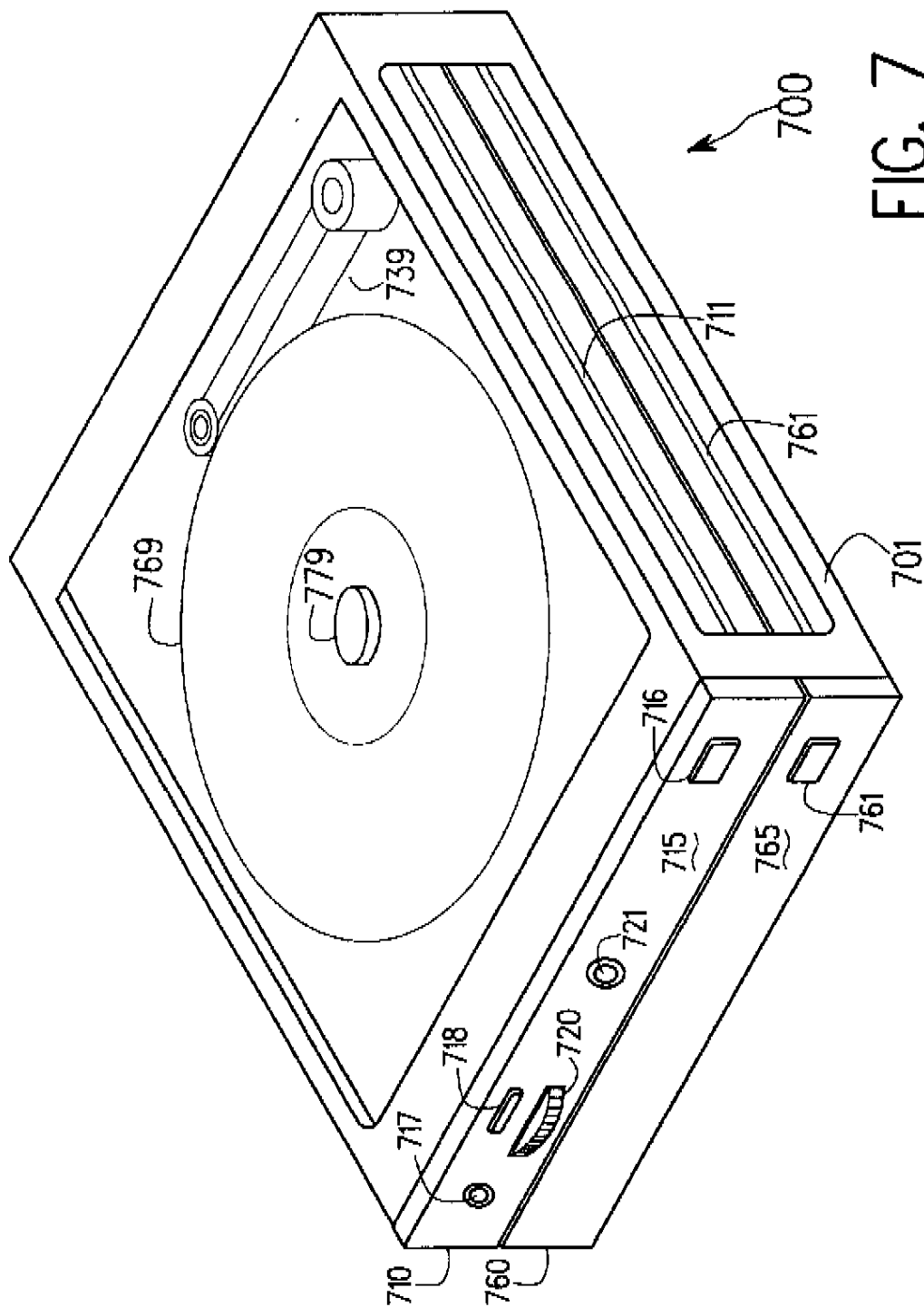

FIG. 7

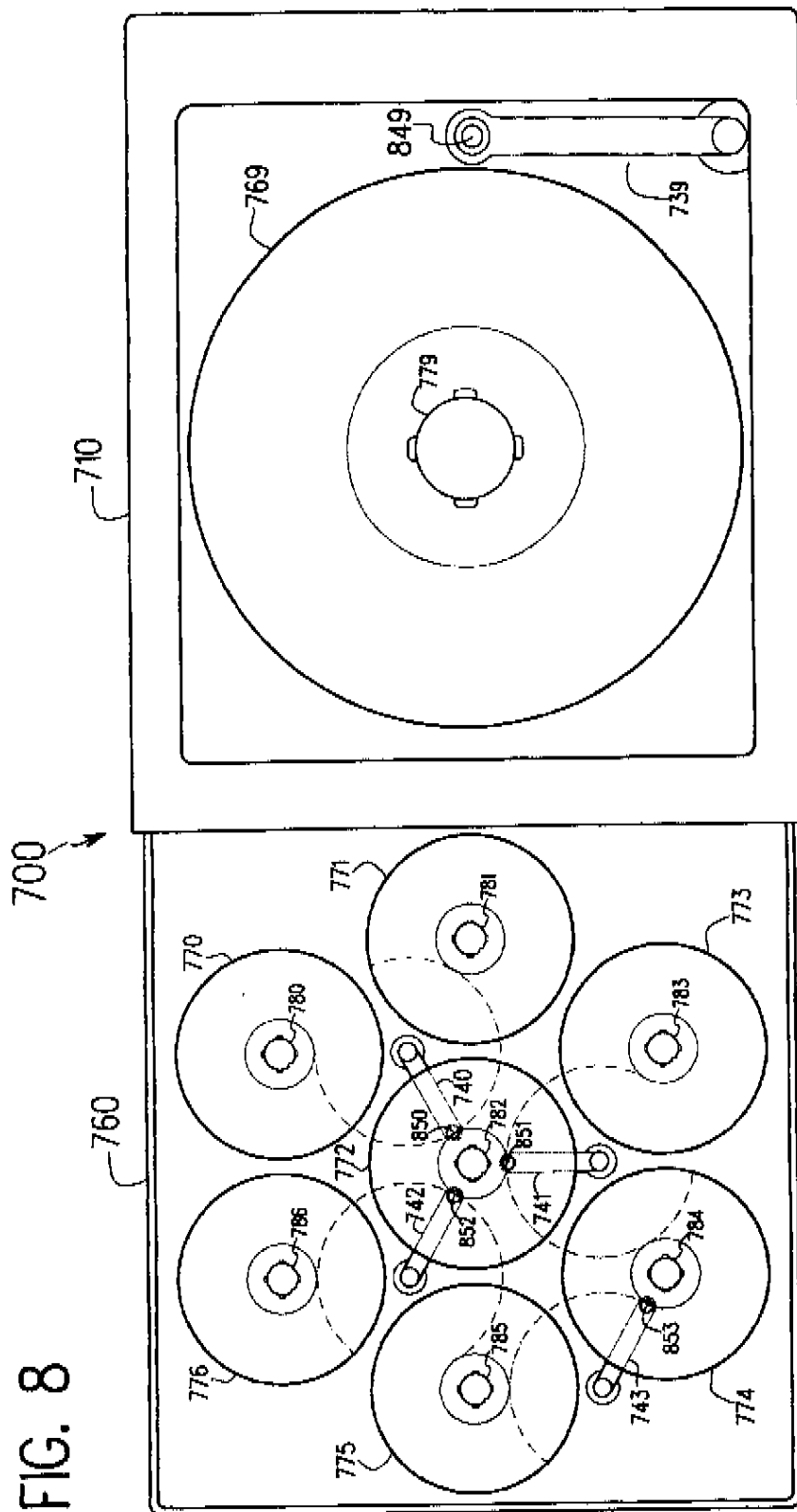
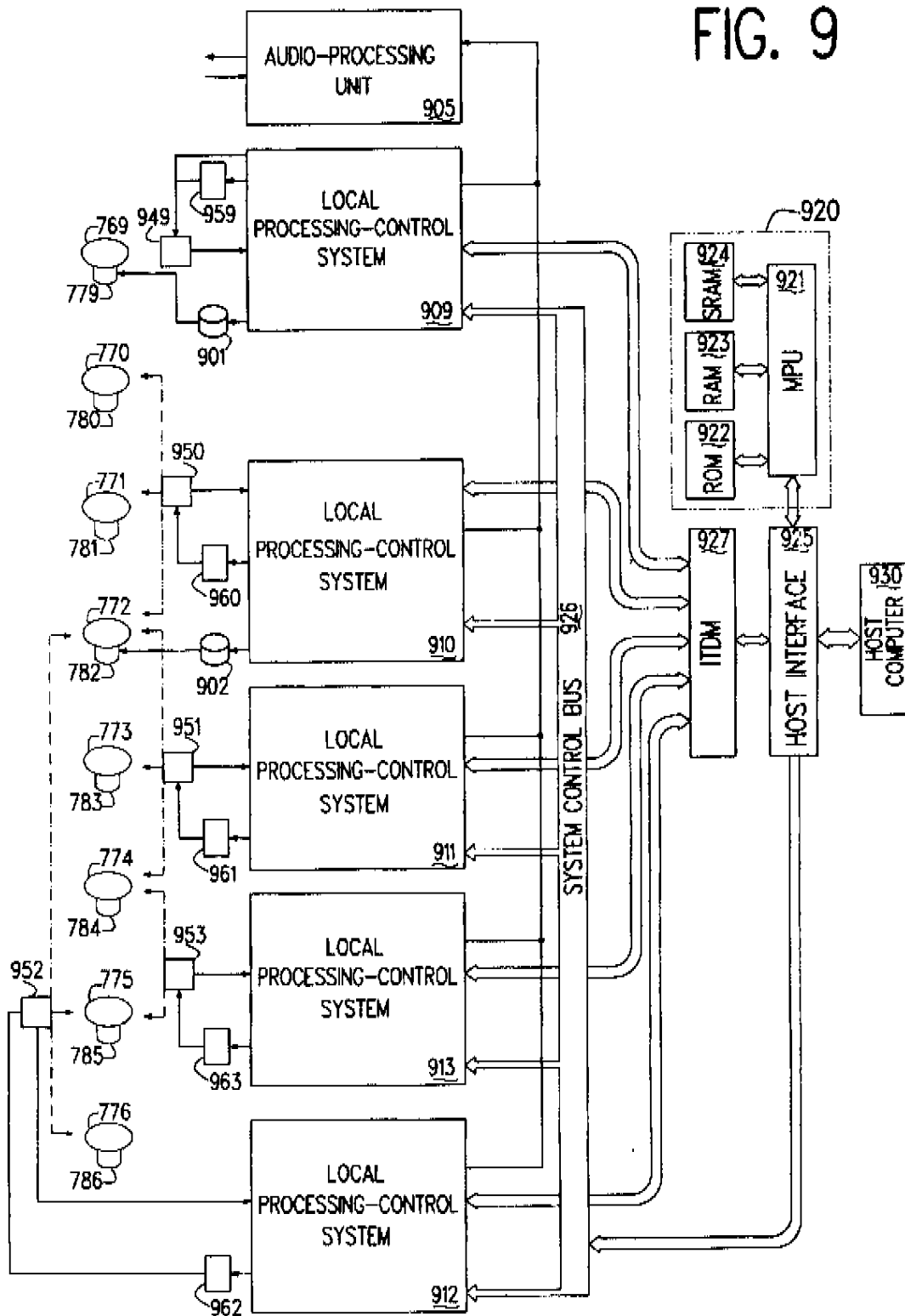

FIG. 9



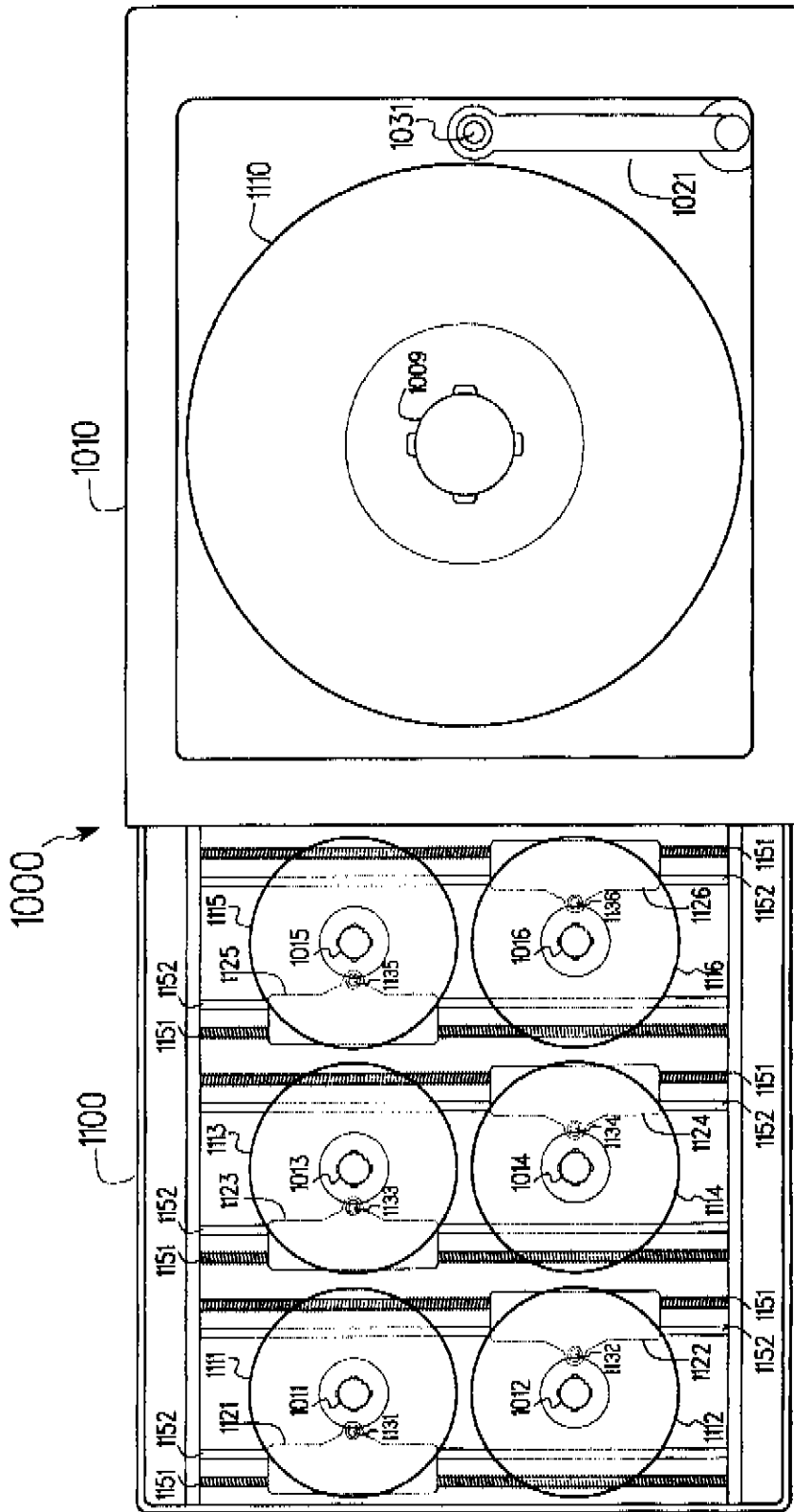

FIG. 10

US 6,222,799 B1

1

HIGH-PERFORMANCE INFORMATION PROCESSING APPARATUS HAVING MULTITASKING FUNCTIONS

This application is a divisional of application Ser. No. 08/850,844 filed May 2, 1997 now abandoned.

FIELD OF THE INVENTION

The present invention relates generally to the field of an information processing apparatus using optical disc media for providing and storing information and more particularly to a high-performance information processing apparatus having multiple and highly-improved functions of secondary and tertiary storage for improving the efficiency of a host computer in performing information processing.

BACKGROUND OF THE INVENTION

It is nowadays essential that a computer system be equipped with a hard-disk drive, a floppy-disk drive, a read-only-memory compact-disc (CD-ROM) drive, and a backup drive either a tape backup drive or a removable-disk drive. Each of these drives had been evolved for taking part in providing some of the multiple functions of secondary and tertiary storage necessary for the computer system to become fully operable in performing information processing.

The function of a hard-disk drive is known to supply on-line information to the microprocessor of a computer system; while, a floppy-disk drive allows a user to install software onto the hard-disk drive and to transport data between computers. This has been the basis for the evolution of conventional computer systems; and, the proceeding of information processing has thus been heavily dependent on the read/write operation of the hard-disk drive. The immediate disadvantage has been that each newly-purchased software program has to go through a tedious, time-consuming installation process through which program files are (decompressedly) copied to the hard-disk drive from which the software program is then launched. This remains in effect regardless of whether software is distributed through optical-disc or floppy-disk media. Aside from the direct cost paid for software, an end user is also incurred with indirect cost for having corresponding hard-disk space for storing the purchased software program.

When a software program is distributed through floppy-disk media, an end user is advised to make a set of backup copies because floppy diskettes are susceptible not only to physical and external damages but to magnetic degradation. Inevitably encountered are other disadvantages: requiring a time-consuming backup process and leaving no room for the software program to be copyright protected.

The practice of installing a purchased software program from purchased software diskettes to a hard-disk drive does not leave much room for software to be copy-right protected. There exist hardware-type protection devices; but, they are affordable only for high-price software programs with an aim of selling at most a few thousand copies for use in trading stocks or futures in real time, for instance. In contrast, volume software programs are sold in sealed envelopes. Once a sealed envelope of a software program is opened, an end user is assumed to accept the software license agreement set by a software developer; and, the software program is not returnable. Unfortunately, there is no practical way to prevent the volume software program from being illegally copied or duplicated. As with the software developers producing high-volume and low-price

2

software programs suffer from their products being illegally copied, the end users lose their opportunity to thoroughly try out a software program before purchasing.

The conventional practice eventually degrades the read/write efficiency of a hard-disk drive. This is because user-created and software-created data files mixedly stored with program files on the hard-disk drive are constantly rewritten, fragmentally relocated, and eventually scattered all over the hard-disk drive. Accordingly, a longer time is needed to find all of the fragmentally-stored data of a large user-created data file. The only remedy currently available for this problem is to routinely run a file-defragmentation process. Unfortunately, as more and more software programs or user-created data files are stored on the hard-disk drive, the file-defragmentation process becomes more and more time-consuming, because it also involves relocation of the program files that occupy most of the hard-disk space but are never changed or altered throughout the entire life of their usage.

Another concern of the conventional practice is that a hard-disk drive is subject to nonphysical damages, for instance, such as program files being truncated or cross-linked due to improper assessing or writing during information reproducing or being infected by computer virus. As a result, software programs become corrupted; and, another tedious software installation process is again needed.

A CD-ROM drive, even though becoming increasingly popularly, plays a much less significant role in information processing when compared with a hard-disk drive. This is clearly reflected in the fact that the CD-ROM drive is designed to serve as tertiary storage for providing off-line archives, for distributing software programs to be installed onto a hard-disk drive, and for playing an audio disc. Often, much of the information originally stored on optical discs has to be copied to the hard-disk drive. Eventually, a mass of information is accumulated in the hard-disk drive. At this point, it becomes highly desirable to have a backup drive either a tape backup drive or a removable-disk drive for storing the accumulated mass information. This not only incurs substantial costs to end users but adds up structural bulkiness and power consumption to the computer systems.

In order to remedy the disadvantages and problems mentioned hereinbefore, my U.S. Pat. No. 5,748,575 advances the role of CD-ROM apparatuses in information processing from tertiary storage to secondary storage. This is achieved by providing a CD-ROM-type information processing apparatus having plural turntables for removably accommodating optical discs thereon, plural head units, control means for controlling the independent movements of the head units, signal-process systems for converting multiple sets of information from a compact disc format to the original state of the information, and data transmitting means for simultaneously transmitting multiple sets of converted information to a host computer. The CD-ROM-type information processing apparatus of U.S. Pat. No. 5,748,575 enables a computer system to simultaneously and multitaskingly launch several software programs directly from original software discs, thus eliminating tedious and time-consuming software installation, affording a kind of copyright protection to software, and alleviating the burden of a hard-disk drive in information reproduction processing. However, the read-only nature of U.S. Pat. No. 5,748,575 disallows any storing of user-created data files, requiring a hard-disk drive for its host computer. The present invention thus makes the optical information processing apparatus of U.S. Pat. No. 5,748,575 to become a master drive having not only multiple but highly-improved functions of second and tertiary storage

US 6,222,799 B1

3

so as to be capable of replacing all of the drives such as hard-disk, floppy-disk, optical-disc, and backup drives that are normally needed in a conventional computer system.

OBJECTS OF THE INVENTION

A first object of the present invention is to provide an information processing apparatus capable of performing not only information reading in multitasking but information writing.

A second object of the present invention is to provide an information processing apparatus having a head unit capable of selectively interacting with at least two optical discs through its driving means, so as to manufacture high-performance information processing apparatus at reduced costs.

A third object of the present invention is to provide an information processing apparatus having plural turntables, plural head units, plural decoding units, at least one encoding unit, and a system control unit so as to afford complete and highly-improved functions of secondary storage and tertiary storage for replacing all of the hard-disk, floppy-disk, optical-disc, and backup drives normally needed in a conventional computer system.

SUMMARY OF THE INVENTION

According to a first preferred embodiment of the present invention, an information processing apparatus comprises plural head units and plural decoding units for multitaskingly performing information reading, and at least one encoding unit for performing information writing with respect to a selected disc surface.

According to a second preferred embodiment of the present invention, an information processing apparatus comprises plural turntables each being rotatable about a respective one of central axes for removably accommodating at least one optical disc, and one head unit capable of positioning its head-means group selectively between the turntables and thus selectively interacting with the optical discs for performing information reading or writing.

According to a third preferred embodiment of the present invention, an information processing apparatus comprises plural turntables each being rotatable about a respective one of central axes for removably accommodating at least one optical disc, plural head units and plural decoding units for multitaskingly performing information reading, at least one encoding unit for performing information writing, and a system control unit for coordinating operation of and for enabling direct communication of the head units, so as to allow said information processing apparatus to possess not only complete but highly-improved functions unobtainable from any combinations of existing hard-disk, floppy-disk, optical-disc, and backup drives that are necessarily equipped in a conventional computer system.

BRIEF DESCRIPTION OF THE DRAWINGS

FIG. 1 is a cutaway side view of an information processing apparatus having two head units capable of selectively performing information reading in multitasking and information writing with respect to one disc surface, in accordance with a first preferred embodiment of the present invention.

FIG. 2 is a block diagram of a control system of the information processing apparatus shown in FIG. 1.

FIG. 3 is a flow chart showing a disc operating system for coordinating operation of the head units to simultaneously

4

process at least two sets of information associated with the same task for improving information-process speed.

FIG. 4 is a top view of an information processing apparatus having one head unit movable selectively between plural turntables, in accordance with a second preferred embodiment of the present invention.

FIG. 5 is an illustrative top view of a head unit and a turntable of FIG. 4, showing a driving means in a cutaway top view and a head-means group in a plan view.

FIG. 6 is a cutaway side view of the head unit and the turntable along the line 6—6 of FIG. 5.

FIG. 7 is a perspective view of an information processing apparatus in a disc-loaded position, in accordance with a third preferred embodiment of the present invention.

FIG. 8 is an illustrative top view of the information processing apparatus seen in FIG. 7, showing five optical head units and eight turntables mounted with discs thereon.

FIG. 9 is a simplified block diagram of a control system of the information processing apparatus shown in FIG. 8.

FIG. 10 is an alternative configuration of plural turntables and plural head units.

DETAILED DESCRIPTION OF THE PREFERRED EMBODIMENT

Referring now to FIGS. 1—3, a first preferred embodiment of the present invention will be described in detail hereinbelow.

FIG. 1 is a cutaway side view of an information processing apparatus with multitasking capability, having two optical head units and one turntable for detachably mounting one optical disc. Apparatus 100 has a structure 101 on which various mechanism components are disposed. The structure allows the apparatus to be either internally installed as a built-in unit in a computer system or covered by a housing for use as a stand-alone unit to be connected to a host computer. Mounted on structure 101 are an electrical board 145, a turntable motor 102, head units 120 and 130. Turntable motor 102 is provided for rotating a turntable 103 that has a disc-setting surface 104 for accommodating an optical disc 140, and a concave portion 105 for accommodating a convex portion 111 of a disc clamp 110. Disc clamp 110 is movable in up/down directions for respectively releasing/clamping optical disc 140.

Head unit 120 basically comprises an optical head means (i.e., pickup) 121 and a driving motor 122. Driving motor 122 is provided for moving optical head means 121 in a direction perpendicular to the central axis of turntable 103 (or in a radial direction of optical disc 140) through rotating a screw shaft 125. Optical head means 121, provided for reading information from and for writing information onto the lower surface 141 of optical disc 140, is supported by a carrier member 123 having a female screw for engaging with screw shaft 125. Screw shaft 125 has a pivoted end 126 rotatably supported by structure 101 and a gear 127 engaged with a gear 128 on driving motor 122, thus forming a driving mechanism for optical head unit 120. Similarly disposed on the other end of structure 101 is head unit 130 that comprises an optical head means 131, a pivoted end 136, a carrier member 133 with a female screw, a gear 137 on screw shaft 135, a gear 138 on driving motor 132, thus forming a driving mechanism for head unit 130. Upon receiving power and control signals, driving motors 122 and 132 independently and simultaneously move respective optical head means 121 and 131 in a radial direction of optical disc 140 to predetermined positions, so as to multitaskingly interact with the lower surface 141 of optical disc 140.

US 6,222,799 B1

5

In order to perform the abovementioned multitasking, turntable motor 102 and thus optical disc 140 are rotated at a constant angular velocity (CAV) method. Even though being reduced to half, the storage capacity of an 120-mm optical disc encoded in the CAV method can still hold a minimum of 250 megabytes of data. Most importantly, the CAV rotation method allows the apparatus of the present invention to rotate at a constant, higher angular velocity for multitaskingly performing high-speed information processing.

FIG. 2 is a block diagram of a control system of the information processing apparatus of FIG. 1. Head units 120 and 130 respectively comprise optical head means 121 and 131, and driving motors 122 and 132. Optical head means 121 and 131 each having elements such as a semiconductor laser diode, objective lens, projection lens, photosensors, λ -4 wave plates, polarizing and beam-splitting prisms, are provided for interacting with optical disc 140. Detailed arrangement of these elements is well known to those skilled in the art of optical storage technology and needs not be repeated here. Optical head means 121 and 131 are respectively interfaced with signal amplifiers 201 and 202, servo controls 211 and 212, local signal-processing systems, and local control units 210 and 260. The local signal-processing system associated with optical head means 121 includes a decoding unit 220 and an encoding unit 230 for proceeding with information reading and writing respectively; while, the local signal-processing system of optical head means 131 includes a decoding unit 270 for information reading only. Local control units 210 and 260 respectively containing MPUs 211 and 261 and ROMs/RAMs (read-only memories and random access memories) 212 and 262 are provided for controlling operation of the respective decoding/encoding units and the respective servo controls in a local level, so as to allow multitasking to take place most effectively.

Signals sensed by optical head means 121 and 131 are very weak and thus respectively amplified by signal amplifiers 201 and 202 to derive usable error signals and high-frequency signals. The derived error signals interface with respective servo controls 211 and 212 for independently controlling the focusing and the radial tracking of optical head means 121 and 131. CAV/CAV control 250 also receives the derived error signals through MPU 261, for selectively controlling the rotation speeds of turntable motor 102 normally at a constant angular velocity (CAV) and at a constant linear velocity (CLV) when either of optical head means 121 and 131 senses CLV-recorded information from optical disc 140. The high-frequency signals from each of signal amplifiers 201 and 202 are in a compact disc format or specifically in the EFM (eight-to-fourteen modulation) format and thus need to be processed by decoding units 220 and 270 respectively comprising CIRC (Cross Interleaved Reed-Solomon Code) decoders 221 and 271, CD decoders 222 and 272, and RAM (random access memory) 223 and 273 in order for the signals to be deinterleaved, demodulated, and decoded for error-correction process, restoring the original sequence of data symbols, and finally converting the 14-bit word back to the original 8-bit data symbols. RAMs 223 and 273 are used in temporarily storing data to be reassembled during the proceeding of the signal processing.

Included in encoding unit 230 are a CIRC encoder 231, a CD encoder 232, and a RAM 233 for encoding a set of information to be stored onto optical disc 140 through optical head means 121. During information writing, a semiconductor laser diode (not shown) contained in optical

6

head means 121 is controlled by local control unit 210 to emit a laser beam at increased output power. Also provided in FIG. 2 are a digital-to-analog converter (D/A Converter) 280 and audio amplifier 281 for sound reproducing, and an audio input 282 and an analog-to-digital converter (A/D Converter) 283 for sound recording.

Local control units 210 and 260 are interfaced by a system control unit 290 containing MPU 291 and ROM/RAM 292 through wide-band host interface 293 and system control bus 294. The read-only memory portion of ROM/RAM 292 contains basic instructions needed for MPU 291 to issue control signals to MPUs 211 and 261 for coordinating operation of head units 120 and 130. ITDM (intelligent time-division multiplexer) 295 and other wide-band buses are provided in order for plural sets of data decoded by decoding units 220 and 270 to be simultaneously transmitted to a host computer 296.

Optical disc 140 may contain information in a digital data format and in a digital audio format needed for running multimedia applications. The table of contents for such a mixed disc uses the digital audio format. Information in the digital data format can be binary programs, ASCII text, graphics, and video images, which are basically associated with producing visual images. The digital data information is stored on data tracks in a sector or block structure including sync, header, data, and/or auxiliary EDC/ECC (error correction and detection) fields. Digital audio data information, however, is read as frames and has to be stored on audio tracks separated from the data tracks. A pre-gap and/or post-gap containing no data is provided to serve as a transition between a data track and an audio track. Under these circumstances, it is difficult for a conventional CD-ROM drive having only one head unit to simultaneously reproduce both the digital data information and the digital audio information in a real time mode, such as playing full-screen, full-motion pictures (requiring 30 frames per second). To the contrary, this can be easily achieved by information processing apparatus 100 of the present invention when a set of instructions are provided for coordinating head units 120 and 130 to perform such a task.

Accordingly, provided in the present invention is a flow chart, FIG. 3, of a disc operating system for coordinating the head units to simultaneously process two sets of information associated with the same reading task of a software program for increasing information-process speed. Note that "S" stands for "Step" hereinafter. When receiving a request signal from host computer 296 for performing a new reading task (S301 and S302), MPU 291 (shown in FIG. 2) determines if there is any idle head unit allocable to the new reading task (S303). If not, MPU 291 interfaces with MPUs 211 and 261 for detecting task-priority-level information (S304) and the activities of head units 120 and 130 to be suspended are stored to the RAM portion of ROM/RAM 292 (S305), and for making the head unit working on the lowest-priority task available as the first head unit to the new reading task (S306). MPU 291 further checks if the RAM portion of ROM/RAM 292 contains the TOC (table of contents) information of optical disc 140 (S307) associated with the new reading task. If not, the first head unit is then instructed to read the TOC information, which is located in the lead-in area of optical disc 140, for obtaining address information associated with the new reading task (S308). The TOC information may include locations of digital data information and digital audio information. S309 determines if the new reading task involves reading of digital audio information. When the new reading task does not involve the reading of digital audio information, the first head unit is

US 6,222,799 B1

7

controlled to read digital data information for the reproduction of the binary program associated with the new reading task, so as to execute the software program and to produce visual images. The digital data information is decoded and temporarily stored in RAM 223 or RAM 273 served as a buffer (S311). S312 determines if host computer 296 is ready for accepting the data temporarily stored in the respective buffer. After the digital data information is sent to host computer 296 (S313), S314 determines if the reading of the digital data information is completed or not. When there involves reading digital audio information (S309), a second head unit is then made available by suspending, if necessary, the activity of the second head unit for reproducing the digital audio information (S315-S317). If both reading digital audio information (S318) and reading digital data information (S314) are completed, head units 120 and 130 are instructed to resume their suspended R/W activities if any (S320). When there is no suspended R/W activity (S319) or the suspended R/W activities are completed (S321), the activities of both head units 120 and 130 are accordingly ended (S322).

In essence, the information processing apparatus comprises a control system unit having microprocessor means and ROM comprising basic instructions for coordinating operation of these head units to simultaneously process at least two sets of information associated selectively with the same task for increasing information-process speed and with different tasks for achieving true multitasking.

Referring now to FIGS. 4-6, a second preferred embodiment of the present invention will be described in detail hereinbelow.

FIG. 4 is a perspective, top view of an information processing apparatus 400 having an optical head unit 401 comprising an optical head-means group 402 and a driving means (or swing mechanism) 403. Driving means 403 is provided for moving optical head-means group 402 to travel through swinging about axis 416 to any disc positions selectively on discs 404-409 that are disposed on respective disc-setting surfaces of turntables 410-415 each being rotatable about a separate one of central axes. Each of the discs has a diameter of 45 mm. The disc-setting surfaces and thus the discs are horizontally aligned with each other and are concentrically disposed at predetermined positions such that the centers of these discs are at an equal distance from axis 416. Underneath turntable 407 is a turntable motor 650 (shown in FIG. 6) for driving turntables 410-415 simultaneously. Each of turntables 410-415 comprises its own disc-loading and releasing means. Thus, without going through other intermediate loading stages (such as internal disc changing or disc selecting used in the prior arts), information reading/writing can be immediately proceeded simply through swinging head-means group 402 about axis 416 to a disc selectively between discs 404-409.

Driving means 403 enables optical head unit 401 to perform a maximum of 350° swing about axis 416, starting from position 418, for accessing any disc positions on discs 404-409. Specifically, head-means group 402 of optical head unit 401 travels in accordance with the phantom circular line 417; thus, any information stored on these discs becomes readily accessible. Because of being designed for discs with smaller sizes and being equipped with a single turntable motor and an optical head unit 401 capable of travelling among discs 404-409, information processing apparatus 400 can be economically produced in a size similar to the commercially available single 120-mm-disc player, installable into the interior of a personal computer.

Discs 404-409 shown in FIG. 4 are arranged in a manner that there is an open space between disc 404 and disc 409 for

8

optical head unit 401 to park at position 418. This open space allows head-means group 402 to contain an upper optical head means 451 and a lower optical head means 452 (shown in FIG. 6) without interfering with the loading/unloading of discs 404 and 409. Objective lenses of optical head means 451 and 452 (FIG. 6) are disposed in a direction facing to each other, so as to allow both surfaces of a selected one of discs 404-409 to be simultaneously accessed. Use of two optical read heads of this type provides twofold advantages: doubling not only the information storage capacity of a disc but the speed of information processing.

FIG. 5 is an enlarged perspective top view of optical head unit 401 with head-means group 402 moved to the lead-in area or the innermost disc position of disc 407 mounted on turntable 413, for illustrating that a single driving means 403 is used to horizontally move optical head-means group 402 selectively between various disc positions as well as between a plurality of discs for information reading/writing in accordance with the present embodiment. The cutaway side view along the line of 6-6 of FIG. 5 is shown in FIG. 6. Optical head-means group 402 supported by a shaft 502 is swingable about axis 416. The swing motion of optical head-means group 402 is powered by driving means 403 through a toothed belt 520.

Turntable 413 seen in FIG. 6 has a turntable shaft 655 which is rotatably connected to the upper shaft of turntable motor 650 fastened to a frame 640. At the top portion of turntable shaft 655 are a disc-setting table surface 660 and disc clamp means 665 retractable into turntable shaft 655 for clamping/releasing disc 407. At the other portion of the shaft of motor 650 is a pulley 651 connected by a toothed belt 652 for transmitting rotation power from turntable motor 650 to other turntables seen in FIG. 4. Accordingly, a plurality of turntables can be driven by a single turntable motor. This reduces construction costs and space for commercializing the optical information processing apparatus of the present invention.

Shaft 502 is rotatably supported by bearings 603 and 604 and has a pivoted end 605 for its swinging. Bearings 603 and 604 are respectively supported by top and bottom supporting frames 605 and 606 fixedly attached to driving means 403. A stop pin 607 fixedly attached to frame 640 and two helical tension springs 608 and 609 arranged in opposite direction are provided in order to produce torque restrain for a steady swing of shaft 502 about its axis 416. A stop pin 610 fixedly attached to the bottom portion of shaft 502 is provided for resting shaft 502 at a reference position. A toothed belt 611 connects a pulley 612 on shaft 502 and a pulley 613 on a moving-coil shaft 620 for transmitting rotation power. Pulley 613 has a diameter larger than pulley 612 so that driving means 403 can provide a maximal swing angle of 350°. This allows optical head-means group 402 to travel rapidly not only between disc positions of a selected disc but between discs 404-409, because the travelling involves only one single-directional movement.

Supported by bearings 621, moving-coil shaft 620 has top and bottom pivots 622 and 623 that are respectively held in place by top and bottom frames 624 and 625 for its swing. One end of moving coil 626 is fixedly attached to moving-coil shaft 620, the other end is allowed to freely travel in the uniform air gap 627 defined by an outer soft-iron pole piece 628 and an inner pole piece 629. Bonded to outer soft-iron pole piece 628 is a magnet 630. An air gap 631 extending to the inner area of a covering frame 632 is provided in order for moving-coil shaft 620 with attached moving coil 626 to be assembled into the configuration of FIG. 5 and also

US 6,222,799 B1

9

allows moving-coil shaft 620 and the fixedly attached end of moving coil 626 to rotate about the axis defined by pivots 622 and 623. Attached to the outer circular area of magnet 630 is a laminated steel shell 633 that acts as a magnetic collector ring and also effectively shields the element from stray fields.

Referring now to FIGS. 7-9, a third preferred embodiment of the present invention will be described in detail hereinbelow.

FIG. 7 is a perspective top, side view of an information processing apparatus 700, having an upper compartment 710 and a lower compartments 760 both currently being in a disc-loaded position. FIG. 8 is a perspective top view of information processing apparatus 700 showing lower compartment 760 extended to a disc loading/unloading position. Compartment transporting means 711 and 761 are provided for making compartments 710 and 760 retractable into (i.e., in a disc-loaded position) and out of (i.e., in a disc-loading/unloading positions) structure 701. On the front panel 715 of upper compartment 710, there are a push-type button 716 for the open/close operation of upper compartment 710, an audio output connector 717 for sound output, a play button 718 for playing a digital audio disc, and a volume control 720 for adjusting sound level. Also equipped in information processing apparatus 700 is a lockout device 721 for locking both compartments 710 and 760 with respect to structure 701 for safeguarding the optical discs stored therein from being unauthorizedly removed. Lockout device 721 is responsive to a mechanical key and to an electrical signal issued by a host computer, allowing the open/close operation of compartments 710 and 760 controllable by the signal generated from the keyboard of a host computer (not shown).

Situated in upper compartment 710 are one 120-mm disc 769 horizontally disposed on turntable 779 and one head unit 739 having a head-means group 849 (FIG. 8) swingable to a predetermined disc position in a direction perpendicular to the central axis of turntable 779 (or in a radial direction of disc 769). Preferably, a disc with audio or multimedia information will be played in this compartment.

Horizontally disposed in lower compartment 760 are seven 45-mm-diameter discs 770-776 stored on respective disc-setting surfaces of turntables 780-786 and four head units 740-743 respectively comprising head-means groups 850-853. Preferably, lower compartment 760 serves as secondary storage for launching software programs directly therefrom and for storing user-created data files and/or software-generated data files. The software-generated data files refer to as the data information such as hardware setting parameters and other data files not related to the program files that are stored on a disc for distribution. Turntables 780-786 and thus their respective disc-setting surfaces, each being rotatable about a separate one of central axes, are arranged in such a manner that discs 770-776 mounted thereon are horizontally aligned with each other. Head-means groups 850-853 are also aligned to the best extent, forming a horizontal travelling plane (consisting of the phantom circular lines) underneath perpendicular to the central axes of turntables 780-786 (or parallel to the disc-surface plane) for facilitating their focusing during interacting with the lower surfaces of discs 770-776. As illustrated by the phantom circular lines, head-means group 850-853 are able to travel selectively between discs 770-772, between discs 772-774, between discs 772, 775 and 776, and between discs 774 and 775, respectively. Information stored on the 45-mm discs is preferably in the CAV scheme, in order for head units 740-743 to perform high-speed,

10

multitasking information processing. A single side of a 45-mm disc of this type is capable of holding a minimum of 60 megabytes of data, sufficient for storing a package of application software programs such as Microsoft Office® containing Microsoft Word® Version 6.0a (about 17 megabytes), Microsoft Excel® Version 5.0 (about 17 megabytes), and Microsoft PowerPoint® Version 4.0 (about 18 megabytes). Use of a 45-mm disc or other small-sized discs is also more realistic than that of an 120-mm disc because software developers such as Microsoft®, IBM®, WordPerfect®, or Lotus® are most likely to produce their own software discs but each of their system or application software programs is not big enough to even fill up 15% of an 120-mm disc capacity. This also gives a user flexibility to choose a preferred program, for instance, a word processing program between WordPerfect® (about 28 megabytes) and Microsoft Word® since both are unlikely to be stored on the same disc.

Disc 772, capable of being simultaneously interacted by three head units 740-742, preferably contains a package of application software programs including, for instance, Microsoft Word®, Excel®, and PowerPoint®. Turntable 784 accessible by head units 741 and 743 is an ideal location for storing a Microsoft Windows® 95 or IBM OS/2® disc containing a disk operating system (DOS) and other shared programs. Discs 775 and 776 may contain erasable/rewritable media for storing data files created by a user or generated by a software program; and, head units 742 and 743 are capable of selectively performing information reading and information writing. While running system and/or application software programs from discs situated in lower compartment 760, a user can enjoy digital music by playing an audio disc situated in upper compartment 710. The individual open/close operation capability of upper compartment 710 and lower compartment 760 further allows the user to change a music disc, when needed, without interrupting his/her active sprograms performed in lower compartment 760, and vice versa.

Owing to the high-speed and multitasking nature of information processing apparatus 700 of the present embodiment, it becomes possible to launch or execute software programs directly from original software discs. This eliminates the conventional, tedious and time-consuming software installation procedure in which a software program stored on a plurality of floppy diskettes or an optical disc has to be (decompressedly) copied to a hard-disk drive from where the software program is then launched.

A simplified block diagram of a control system of information processing apparatus 700 is shown in FIG. 9. Head units 739-743 respectively contain optical head means 949-953, and driving means 959-963 that are respectively interacted by local processing-control systems 909-913. Each of local processing-control systems 909-913 contains a local control unit (each having a MPU and a ROM/RAM), and a decoding unit. Local processing-control systems 912 and 913 each additionally comprises an encoding unit for performing information writing. Each of the local control units controls operation of a respective one of the head units, a respective one of the decoding/encoding units, and a respective one of the servo controls in a local level, so as to allow multitasking to take place most effectively. Conversion of audio data between analog and digital formats is performed by an audio-processing unit 905. Turntable motors 901 and 902 rotate respective turntables 779 and 780-786 either at a CLV scheme or at a CAV scheme. A system control unit 920, comprising MPU a 921, a ROM 922, a RAM 923, and a SRAM (static randomaccess

US 6,222,799 B1

11

memory) 924, is connected to each of the local processing-control systems 909-913 for interacting with a host computer 930 and for coordinating the local operations of the local control units contained in local processing-control systems 909-913 through wide-band host interface 925 and system control bus 926. In essence, system control unit 920 coordinates operation of head units 740-743 in interacting with discs 770-776 so as to allow selected two of head units 740-743 to simultaneously process two sets of information associated selectively with the same task for improving information-process speed and with different tasks for achieving true multitasking. ROM 922 contains basic instructions needed for MPU 921 to issue control signals to the local control units contained in local processing-control systems 909-913; and, RAM 924 is provided for temporarily storing information such as the suspended activities of head units 739-743 during information processing. SRAM 924 is afforded for storing basic information such as the read-only or erasable/rewritable nature of discs 769-776 and directory-structure information or path tables of discs 769-776, allowing information processing apparatus 700 to instantly determine the very disc with which a new task is to be proceeded. This also eliminates the step of requesting each head unit to read the TOC information of each respective disc, when host computer 930 is booted. Thus, any new reading/writing task can be instantly executed. Other bootstrap data affecting the booting of host computer 930, such as a user-defined file of autoexec.bat, is also preferably stored and updated on SRAM 924 for high-speed performance, although it can be stored on disc 775. Thus, host computer 930 can be booted in no time. ROM 922 further contains instructions to request the information contained in SRAM 924 to be verified or updated before the shutdown of information processing apparatus 700. Thus, the basic information contained in SRAM 924 always remain updated so as to ensure that any information-writing or information-reading request can be launched instantly. Use of the SRAM eliminates the need to refresh the contents of the information/instructions many times a second; thus, the information/instructions can be retained through power of a battery. IFDM 927 and other wide-band buses are provided for simultaneously transmitting a plurality of sets of data generated from local processing-control systems 909-913 to host computer 930.

In accordance with the present invention, none of the program files stored on read-only discs 770-774 shall be copied to erasable/rewritable disc 775 or 776. This essentially eliminates a tedious, time-consuming software-installation process; therefore no operating burden will be added to head unit 742 or 743. Information reading and information writing thus can be proceeded in a high-speed, multitasking manner. Preferably, a software program is written in a manner capable of communicating with the basic information stored in SRAM 924 so that a user is automatically prompted to set up a directory for storing user-created and/or software-generated data files on disc 775 or 776, if the directory for storing user-created and/or software-generated data files is not yet created.

Because user-created data files and/or software-generated data files are stored on erasable/rewritable discs 775 and 776 separated from program files stored on read-only discs 770-774, no tedious, time-consuming file-defragmentation process will ever be needed. With the coexistence of system control unit 920 and the local control units, information exchanging or direct communication between the head units and thus between the discs separately mounted thereon can be established. For example, through head units 742 and

12

743, files can be copied directly from erasable/rewritable disc 775 to erasable/rewritable disc 776 for making off-line archives without involving or going through host computer 930. Such direct interfacing/communication is not available in conventional computer systems between a hard-disk drive and a floppy-disk drive, or other removable disk drive. The separation of user-created and/or software-generated data files from program files limits the amount of the data files that need to be transported or secured. In conventional practice, the feature of allowing a selected one of discs removable is only achievable when several information-storage drives such as a hard-disk drive and a removable-disk drive are combined, but at the expense of incurring additional costs and hardware bulkiness. Accordingly, information processing apparatus 700 not only possesses complete functions of a hard-disk drive, a floppy-disk drive, an optical-disc drive, and a backup drive that are normally needed in conventional practice, but provides highly-improved functions of secondary storage and tertiary storage that are not achievable by any combinations of the conventional information-storage derives.

Shown in FIG. 10 is an information processing apparatus 1000 with an alternative configuration of turntables and head units, having a compartment 1100 different from compartment 760 shown in FIG. 8. Compartment 1010 of FIG. 10 contains a turntable 1009 mounted with a disc 1110 and a head unit 1021 having an optical head means 1031; while, compartment 1100 contains turntables 1011 and 1012 respectively mounted with magneto-optical discs 1111 and 1112, four turntables 1013-1016 respectively bearing read-only discs 1113-1116, and six head units 1121-1126. Magneto-optical discs 1111 and 1112 contain magnetically-sensitive, metallic crystals whose orientations are re-alignable only when exposed to an intense laser beam and magnetic impulse, thus being erasable/rewritable. Each of head units 1121-1126 is capable of linearly moving along a respective screw shaft 1151 and a respective sliding rail 1152 by a predetermined distance in a radial direction of a respective one of the discs (or in a direction perpendicular to a respect one of central axes of turntables 1011-1016) so as to position each respective one of optical head means 1131-1136 at a predetermined disc position for performing information processing. Head units 1121 and 1122, each further comprising means for generating magnetic impulses, are able to selectively perform information reading and writing. Discs 1111 and 1112, discs 1113 and 1114, and discs 1115 and 1116 are respectively aligned with each other. Thus, each of discs 1111-1116 can be either interacted either by one optical head means or by two optical head means simultaneously for achieving high-speed, high-performance information processing.

While FIGS. 8 and 9 show a configuration in which head-means groups 850-853 each contains a respective one of optical head means 950-953 for interacting with the lower surface of a respective one of discs 770-776, it is possible that some of the head-means groups 850-853 each contains two optical head means for interacting simultaneously with both surfaces of a selected disc. Configurations other than FIGS. 8-10 are also possible; similarly, a turntable of the present invention can also be rendered detachable for mounting a disc-pack cartridge consisting of plural erasable/rewritable discs and a head-means group can be made to have plural head means each interacting with a respective disc surface of the plural erasable/rewritable discs so as to store a mass of data. Thus, the preferred embodiments of the present invention mentioned hereinabove are provided by way of example only. Numerous variations,

US 6,222,799 B1

13

changes, modification, and substitutions will occur to those skilled in the art without departing from the invention herein. Accordingly, it is intended that the invention be limited only by the spirit and scope of the appended claims.

What is claimed is:

1. An information processing apparatus comprising:

- (a) a structure;
- (b) a plurality of turntables disposed within said structure, each of said turntables being rotatable about a respective one of central axes and having means for mounting at least one disc thereon;
- (c) a head unit having a driving means and a head-means group, said driving means being provided for moving said head-means group in a direction perpendicular to said central axes, wherein said head-means group comprises at least one optical head means each for interacting with a disc surface;
- (d) at least one decoding unit, each being provided for decoding a set of encoded information retrieved by one of said optical head means;
- (e) at least one encoding unit, each being provided for encoding a set of information to be stored; and
- (f) means for controlling said driving means to move said head-means group selectively between said turntables; whereby said turntables and said head unit are adapted in such a manner as to allow said head-means group to travel selectively between said turntables and thus between corresponding discs mounted thereon.

2. The information processing apparatus of claim 1 further comprising writable memory-storing means for storing information comprising bootstrap data, table of contents data, volume table of contents data, and directory-structure data of corresponding discs mounted on said turntables.

3. The information processing apparatus of claim 1 further comprising means for enabling at least one of said turntables each to be detachable for mounting said at least one disc on said means for mounting.

4. An information processing apparatus comprising:

- (a) a structure;
- (b) a plurality of turntables disposed within said structure, said turntables each being rotatable about a respective one of central axes and having means for mounting at least one disc thereon;
- (c) a plurality of head units each having a driving means and a head-means group, each of said driving means being provided for moving a respective one of said head-means groups in a direction perpendicular to at least one of said central axes, wherein each of said head-means groups comprises at least one optical head means each for interacting with a disc surface;
- (d) at least one decoding unit each being provided for decoding a set of encoded information retrieved by one of said optical head means;
- (e) at least one encoding unit, each being provided for encoding a set of information to be stored; and
- (f) means for simultaneously controlling said plurality of head units, said at least one decoding unit and said at least one encoding unit to process information in multitasking.

5. The information processing apparatus of claim 4 further comprising means for simultaneously transmitting at least two sets of information between said information-storage apparatus and a host computer.

6. The information processing apparatus of claim 4, wherein said turntables and said head units are adapted in such a manner as to allow at least one of said head units each

14

to move a respective head-means group selectively between at least two of said turntables and thus corresponding discs mounted thereon.

7. The information processing apparatus of claim 4, wherein said turntables and said head units are adapted in such a manner as to allow at least one of said turntables each to be accessible simultaneously by at least two of said head units, such that said information processing apparatus can utilize at least two head means to interact simultaneously with a selected disc surface for processing at least two sets of information associated selectively with the same task for improving information-process speed and with different tasks for achieving true multitasking.

8. The information processing apparatus of claim 4, wherein said means for simultaneously controlling comprises local control units each for controlling a respective one of said head units to perform information processing in a local manner and a system control unit for coordinating operation of said local control units to simultaneously process said at least two sets of information.

9. The information processing apparatus of claim 4 further comprising local control units each for controlling a respective one of said head units to perform information processing in a local manner and a system control unit connecting to at least two of said local units for enabling and controlling direct communication between at least two of said head units, so as to allow information to be sent directly from a first one to a second one of said at least two head units without going through a host computer.

10. The information processing apparatus of claim 4 further comprising a system control unit for coordinating operation of said head units to simultaneously process at least two sets of information associated selectively with the same task for improving information-process speed and with different tasks for achieving true multitasking.

11. The information processing apparatus of claim 10, wherein said system control unit further comprises micro-processor means, read-only-memory means, and writable memory-storing means.

12. The information processing apparatus of claim 11, wherein said read-only-memory means further comprises a set of basic instructions for coordinating operation of said head units in performing a new reading task with respect to a selected disc surface, said set of basic instructions including:

- (a) detecting task-priority-level information of said head units;
- (b) allocating a first head unit having the lowest-priority level in accordance with said task-priority-level information to said new reading task;
- (c) requesting said first head unit to read table of contents information of said selected disc for obtaining address information associated with said new reading task, if said address information being not available;
- (d) if said address information including digital audio information, allocating a second head unit having the second lowest-priority level in accordance with said task-priority-level information to said new reading task for reading said digital audio information;
- (e) storing suspended activities of said first and said second head units, if any, to said writable memory-storing means; and
- (f) resuming said suspended activities, if any, when said new task being accomplished.

13. The information processing apparatus of claim 4 further comprising writable memory-storing means for storing information comprising bootstrap data, table of contents data, volume table of contents data, and directory-structure data of corresponding discs mounted on said turntables.