

UNITED STATES DISTRICT COURT
NORTHERN DISTRICT OF FLORIDA

ENTER-MET THERMOCHEMICAL
ENGINEERS, INC.,

Plaintiff,

CASE NO. 5:02CV105 RH/WCS

v.

THEORETICAL THERMIONICS,
INC.

Defendant.

COMPLAINT FOR A DECLARATORY JUDGMNET

COMES NOW the Plaintiff, ENTER-MET THERMOCHEMICAL ENGINEERS, INC., pursuant to Rule 3, Federal Rules of Civil Procedure, by and through its undersigned attorney, and alleges as follows:

JURISDICTION AND VENUE

1. Plaintiff is a Florida corporation having its principal place of business in Panama City, Florida.
2. Defendant is a foreign corporation incorporated in the State of Ohio, and having its principal place of business in McDonald, Ohio.

OFFICE OF CLERK
U.S. DISTRICT CT
NORTHERN DIST. OF FLA.
TALLAHASSEE, FLA.
02 MAR 14 PM 12:57

FILED

3. This action arises under 28 U.S.C. §1338(a) (United States Patent Laws), as will be disclosed hereinafter.

4. Jurisdiction is proper in this court.

5. Venue for this action is proper in this court under the provisions of 28 U.S.C. §2201(a).

GENERAL ALLEGATIONS

6. Defendant, THEORETICAL THERMIONICS, INC. (hereinafter "TTI") is the assignee of the entire right, title, and interest in the following patents:

U.S. Patent No. 5,950,547 to Wachendorfer (1999)

(hereinafter "the '547 patent"); and

U.S. Patent No. 6,216,613 to Wachendorfer (2001)

(hereinafter "the '613 patent").

The '547 patent is attached hereto as Exhibit A. The '613 patent is attached hereto as Exhibit B.

7. The '547 and '613 patents contain claims covering a coal combustor, including a coal gasification device, and the process generally carried out by the coal combustor.

8. Plaintiff, ENTER-MET THERMOCHEMICAL ENGINEERS, INC. (hereinafter "ETE"), is a company formed to develop products in the field of coal gasification and combustion, among other things.

9. The principals of ETE have discussed with the principals of TTI the possibility of ETE purchasing certain

hardware and technology from TTI. In the course of these discussions, ETE made plain its intent to develop coal gasification and combustion hardware which could arguably fall under one or more of the claims of the '547 and '613 patents.

10. ETE does, in fact, have a present intention of developing gasification and/or combustion hardware which could arguably fall under one or more of the claims of the '547 and '613 patents.

11. Discussions between ETE and TTI eventually terminated with no agreement being reached. During the course of these discussions, TTI made clear that if ETE pursued its plans of developing the proposed gasification and/or combustion hardware without first obtaining a license (or outright purchase) of the '547 and '613 patents, that TTI would consider ETE's actions to be patent infringement.

12. Because of the foregoing, ETE is in doubt as to its rights under the patent laws of the United States.

13. ETE has produced designs for the proposed hardware, and is presently in the process of refining these designs. Because of the existing controversy, ETE has refrained from fabricating actual hardware.

14. Insomuch as ETE is prevented from pursuing its hardware development plans by the uncertainty regarding infringement, there presently exists a justiciable controversy between ETE and TTI.

FIRST CLAIM
(LACK OF 35 U.S.C. §112 ENABLEMENT AS TO '547)

15. 35 U.S.C. §112 reads, in pertinent part:

The specification shall contain a written description of the invention, and of the manner and process of making and using it, in such full, clear, concise, and exact terms as to enable any person skilled in the art to which it pertains, or with which it is most nearly connected, to make and use the same, and shall set forth the best mode contemplated by the inventor of carrying out his invention.

16. The '547 patent does not comply with 35 U.S.C. §112 in that its disclosure is insufficient to enable one skilled in the art to make and use the invention.

WHEREFORE, Plaintiff respectfully asks this court to enter a judgment declaring the '547 patent to be invalid.

SECOND CLAIM
(LACK OF 35 U.S.C. §112 ENABLEMENT AS TO '613)

17. The '613 patent does not comply with 35 U.S.C. §112 in that its disclosure is insufficient to enable one skilled in the art to make and use the invention.

WHEREFORE, Plaintiff respectfully asks this court to enter a judgment declaring the '613 patent to be invalid.

THIRD CLAIM
(LACK OF 35 U.S.C. §112 BEST MODE AS TO '547)

18. At the time the inventor of the '547 applied for the patent, he knew of certain additional elements which were required to practice the invention, yet he failed to disclose these additional elements in his application for a U.S. patent.

19. The '547 patent thereby fails to comply with Section

112's "best mode" requirement, in that it fails to set forth the best mode known to the inventor of carrying out his invention.

WHEREFORE, Plaintiff respectfully asks this court to enter a judgment declaring the '547 patent to be invalid.

**FOURTH CLAIM
(LACK OF 35 U.S.C. §112 BEST MODE AS TO '613)**

20. At the time the inventor of the '613 applied for the patent, he knew of certain additional elements which were required to practice the invention, yet he failed to disclose these additional elements in his application for a U.S. patent.

21. The '613 patent thereby fails to comply with Section 112's "best mode" requirement, in that it fails to set forth the best mode known to the inventor of carrying out his invention.

WHEREFORE, Plaintiff respectfully asks this court to enter a judgment declaring the '613 patent to be invalid.

**FIFTH CLAIM
(OBVIOUSNESS OF '547 UNDER 35 U.S.C. §103)**

22. 35 U.S.C. §103(a) reads as follows:

A patent may not be obtained though the invention is not identically disclosed or described as set forth in section 102 of this title, if the differences between the subject matter sought to be patented and the prior art are such that the subject matter as a whole would have been obvious at the time the invention was made to a person having ordinary skill in the art to which the subject matter pertains. Patentability shall not be negatived by the manner in which the invention was made.

23. The invention as claimed in the '547 patent would have been obvious to a person having ordinary skill in the art of

gasification and combustion at the time the invention was made.

24. Accordingly, the '547 patent is invalid under 35 U.S.C. §103(a)

WHEREFORE, Plaintiff respectfully asks this court to enter a judgment declaring the '547 patent to be invalid.

**SIXTH CLAIM
(OBVIOUSNESS OF '613 UNDER 35 U.S.C. §103)**

25. The invention as claimed in the '613 patent would have been obvious to a person having ordinary skill in the art of gasification and combustion at the time the invention was made.

26. Accordingly, the '613 patent is invalid under 35 U.S.C. §103(a)

WHEREFORE, Plaintiff respectfully asks this court to enter a judgment declaring the '613 patent to be invalid.

Respectfully submitted this 12th day of March, 2002.



J. WILEY HORTON
Pennington, Moore, Wilkinson, Bell
& Dunbar, P.A.
215 S. Monroe St.,
2nd Floor
Tallahassee, Florida 32301
(850) 222-3533
(850) 222-2126 fax

FLA Bar No. 0059242

A

United States Patent [19]
Wachendorfer

[11] **Patent Number:** **5,950,547**
 [45] **Date of Patent:** **Sep. 14, 1999**

[54] **COMBUSTOR FOR BURNING A COAL-GAS MIXTURE**
 [75] **Inventor:** Paul Wachendorfer, Carrollton, Ohio
 [73] **Assignee:** Theoretical Thermionics, Inc.,
 McDonald, Ohio

3,944,142	3/1976	Welden et al.	239/552
4,156,625	5/1979	Wachendorfer, Sr.	
4,457,241	7/1984	Itse et al.	110/347
4,546,827	10/1985	Wachendorfer, Sr.	165/165
4,681,531	7/1987	Nagy et al.	431/181
5,113,771	5/1992	Rini et al.	110/263
5,146,858	9/1992	Tokuda et al.	110/261

[21] **Appl. No.:** 08/897,939
 [22] **Filed:** Jul. 21, 1997
 [51] **Int. Cl.⁶** F23D 1/00; F23C 1/12;
 F23K 3/02
 [52] **U.S. Cl.** 110/263; 110/104 B; 110/261;
 110/264
 [58] **Field of Search** 110/104 B, 260,
 110/261, 262, 263, 264, 265, 266, 297,
 301, 309, 310, 313, 314, 317, 322, 323,
 327, 347, 346

Primary Examiner—Ira S. Lazarus
Assistant Examiner—Ljiljana V. Ciric
Attorney, Agent, or Firm—Watts, Hoffmann, Fisher & Heinke Co.

[57] **ABSTRACT**

A coal combustor for combustion of coal in fossil burning plants, comprising a refractory including a reactor chamber, combustion chamber, and discharge chamber serially connected along a central longitudinal axis. The chambers define, respectively a reactor zone, combustion zone, and discharge zone extending through the refractory. A ceramic baffle insert is concentrically disposed within the forward end of the reactor chamber. The baffle defines at least one coal-gas passage extending longitudinally through the baffle and communicates an air-fuel mixture to the reactor zone. A reactor core tube is sealingly engaged by the baffle and in communication with the coal-gas passage. The reactor core tube extends longitudinally through a portion of the reactor zone and terminates in the combustion zone for communicating a coal-gas mixture from the coal-gas passage to the combustion zone. The air-fuel mixture is burned in the reactor zone to heat the reactor core tube and the coal-gas mixture passing through the reactor core tube by conduction, before entry into the combustion zone.

[56] **References Cited**
U.S. PATENT DOCUMENTS

1,527,214	2/1925	Peabody	
1,628,424	5/1927	Peabody	
1,870,013	8/1932	Keenan, Jr.	
1,995,934	3/1935	Mangold	
2,480,547	8/1949	Caracisti	431/188
2,525,432	10/1950	Stadler	431/349
2,617,405	11/1952	Keller	
2,815,069	12/1957	Garraway	431/188
2,838,103	6/1958	Voorheis	431/176
2,889,871	6/1959	Voorheis	431/9
3,145,670	8/1964	Copian et al.	431/184
3,411,716	11/1968	Stephan et al.	239/132.3
3,743,471	7/1973	Jaeger	431/115

19 Claims, 4 Drawing Sheets

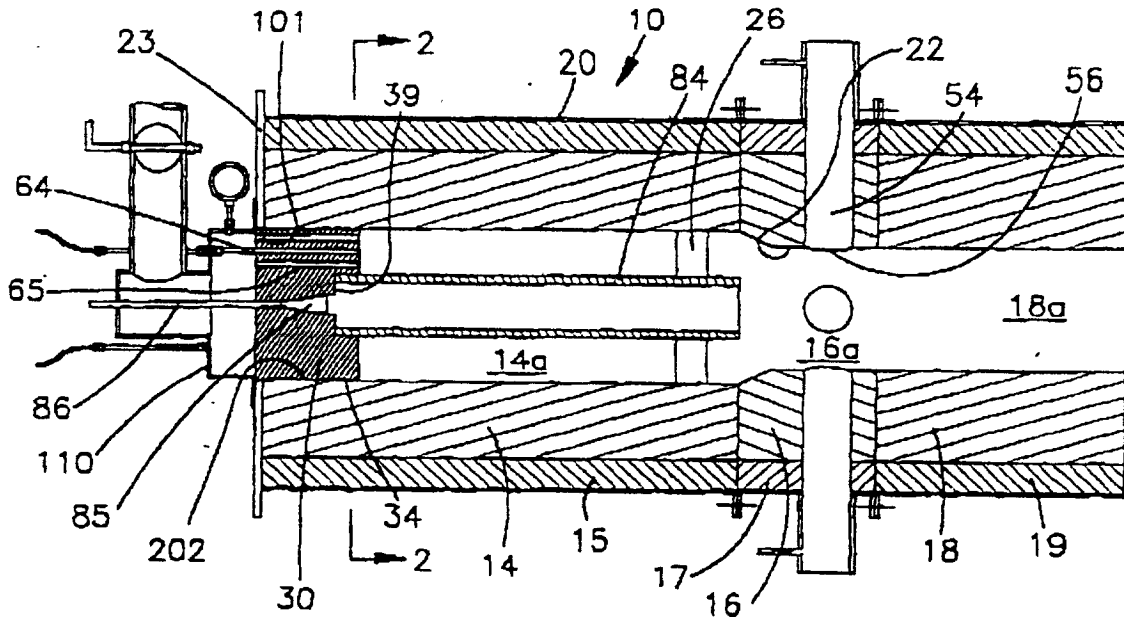

U.S. Patent

Sep. 14, 1999

Sheet 1 of 4

5,950,547

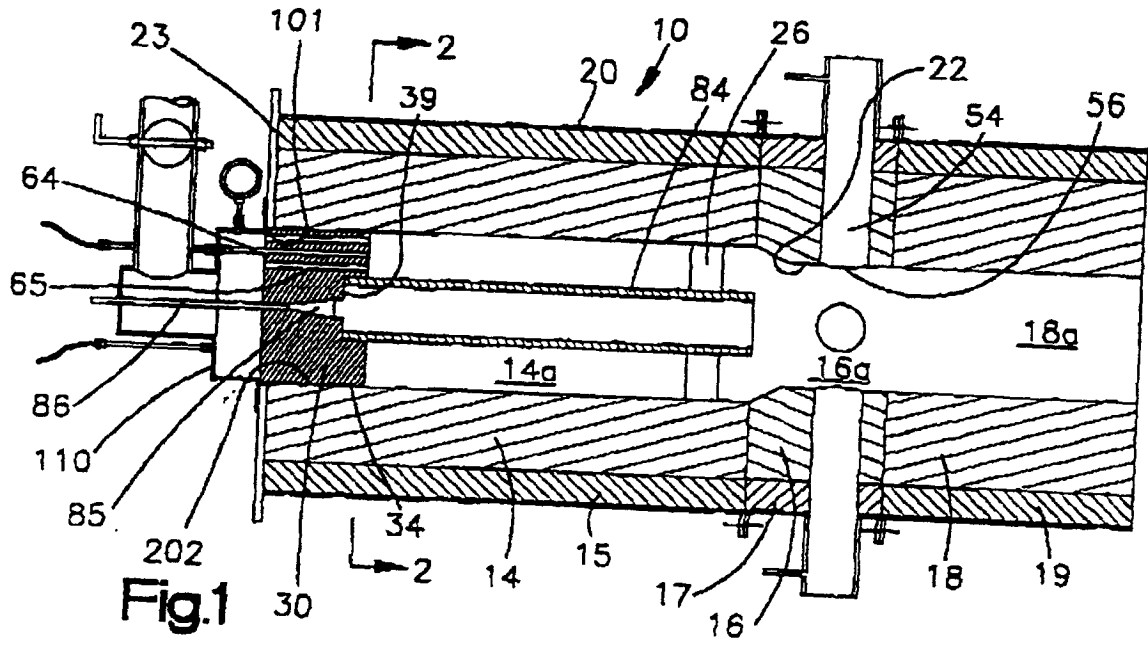

Fig. 1

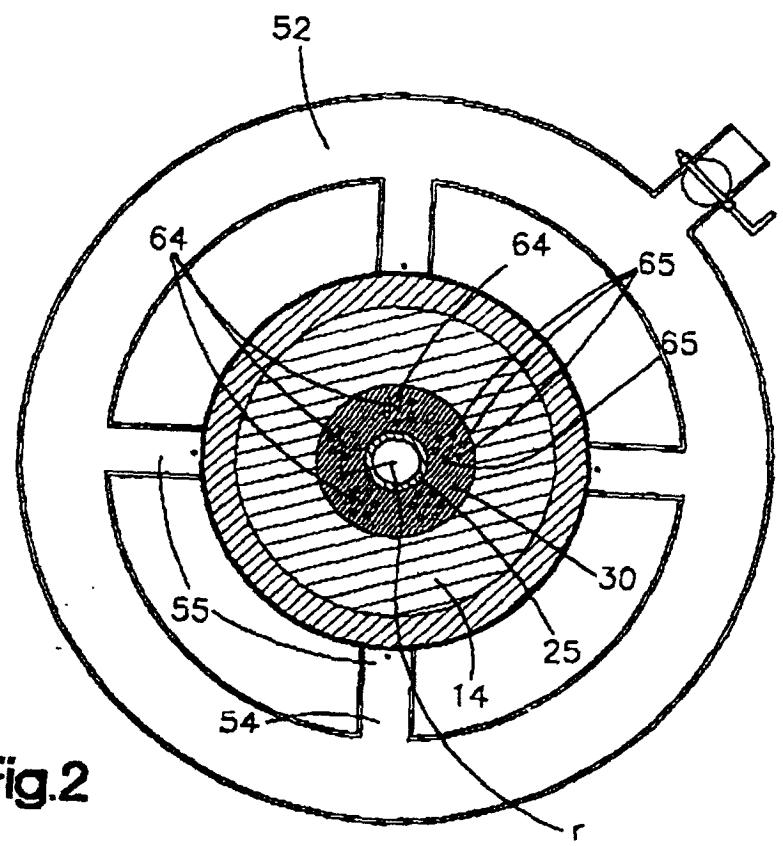

Fig. 2

U.S. Patent

Sep. 14, 1999

Sheet 2 of 4

5,950,547

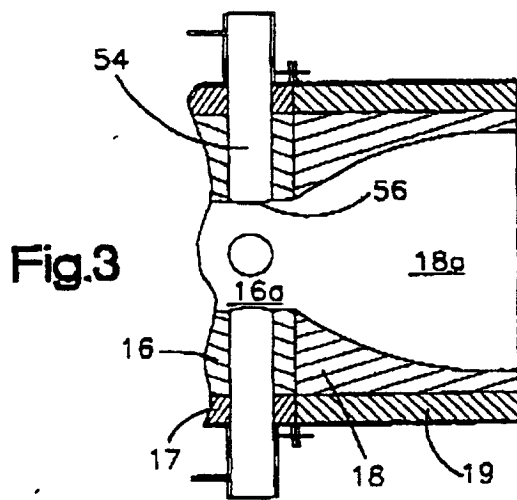

Fig. 3

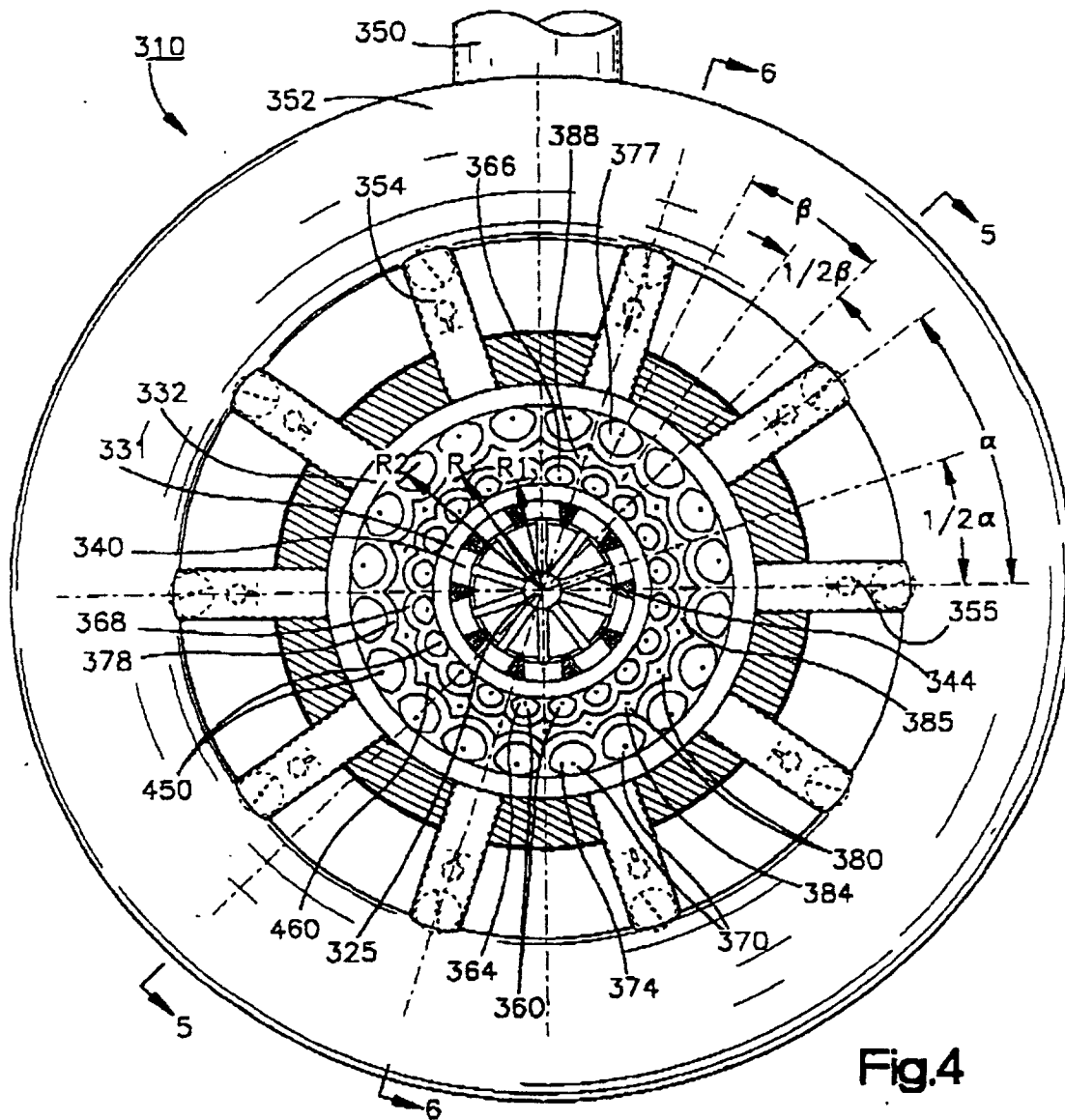

Fig. 4

U.S. Patent

Sep. 14, 1999

Sheet 3 of 4

5,950,547

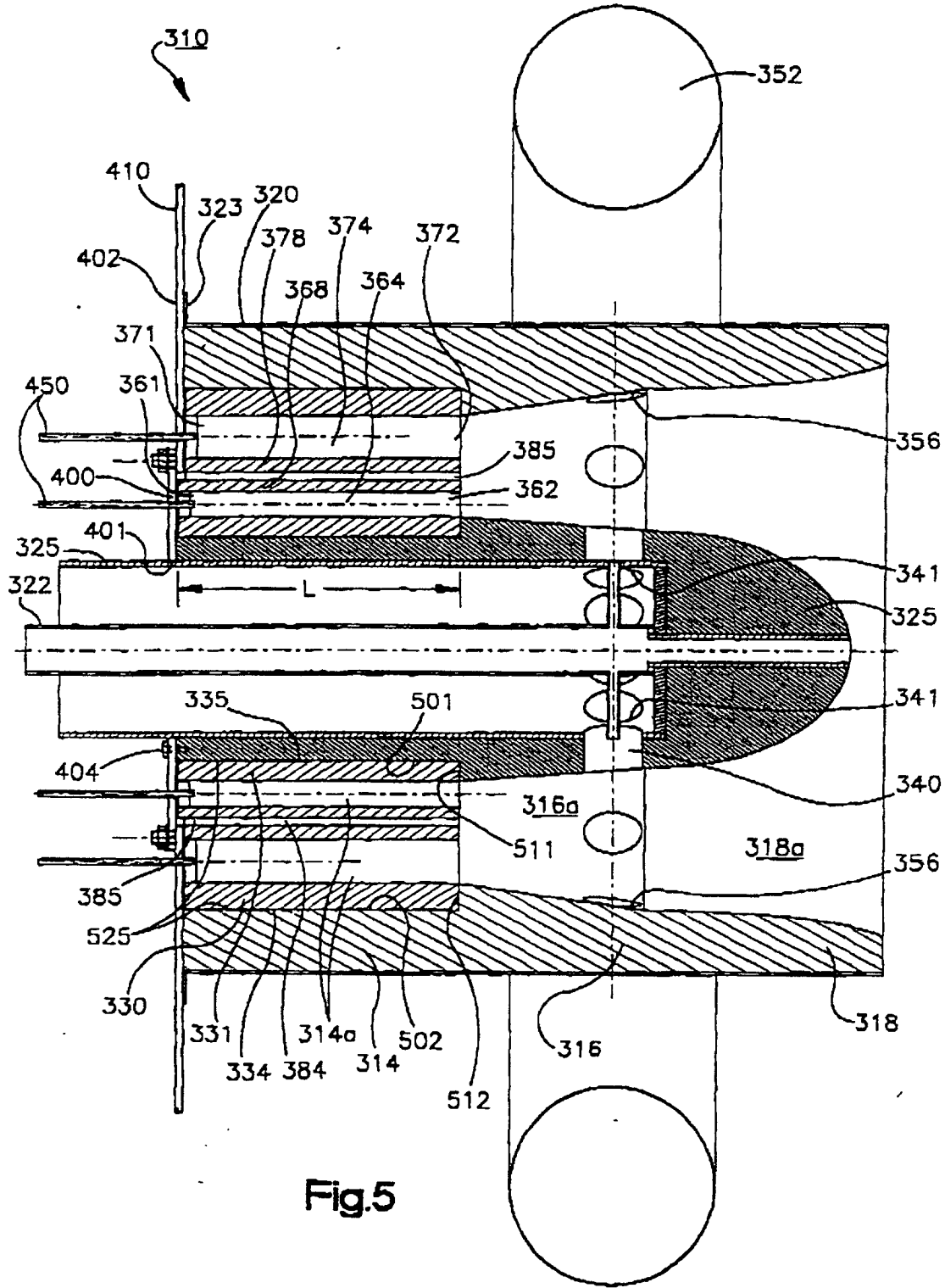

Fig. 5

U.S. Patent

Sep. 14, 1999

Sheet 4 of 4

5,950,547

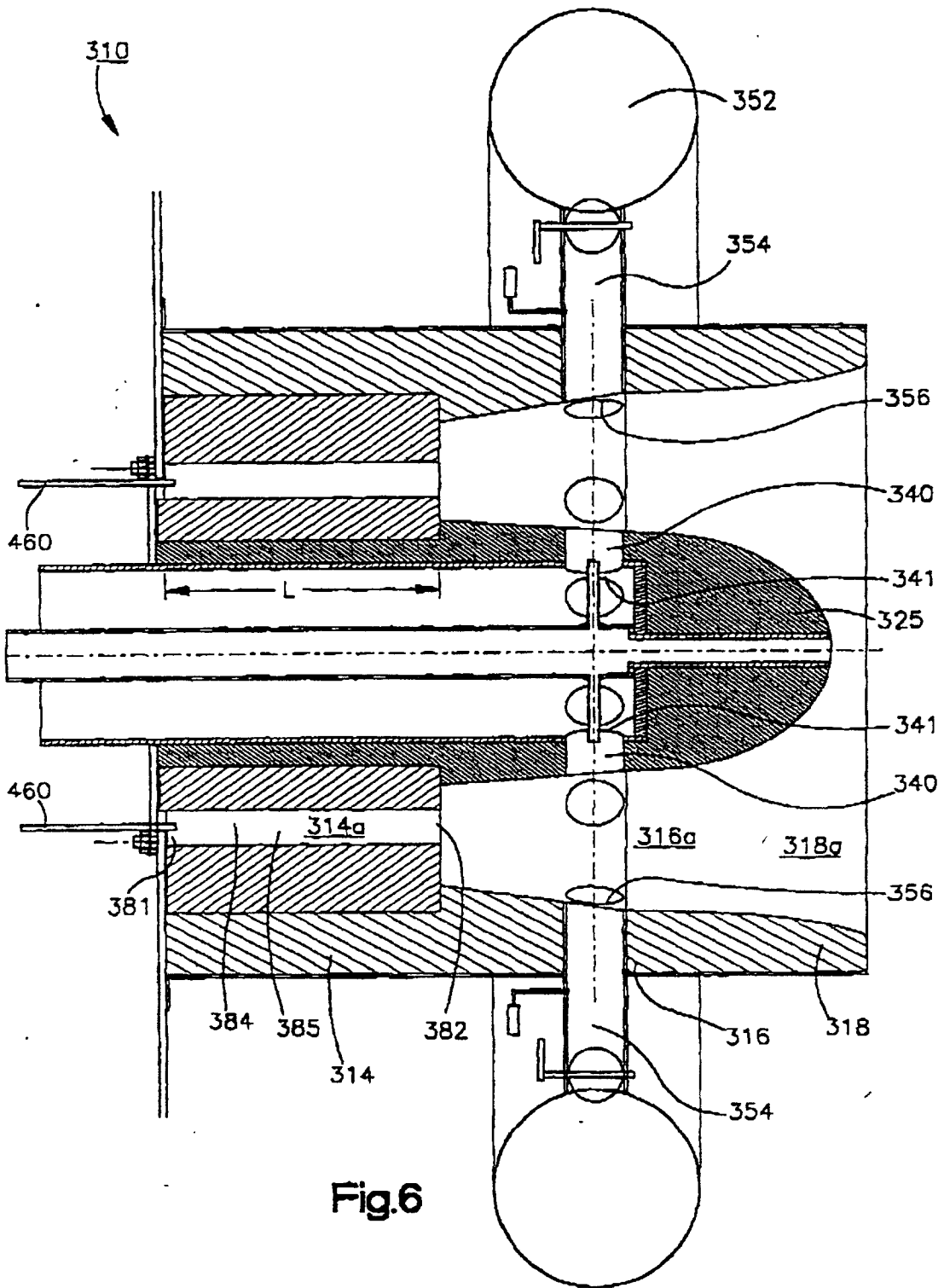

Fig.6

5,950,547

1
COMBUSTOR FOR BURNING A COAL-GAS MIXTURE

FIELD OF THE INVENTION

The present invention relates generally to a coal combustor and, more specifically, will be referred to as an entropic reactor for the combustion of coal in fossil burning plants, such as utility plants.

BACKGROUND ART

Most fossil burning plants, such as utility plants, presently utilize a burning or firing combustion process in which most of the thermochemical reaction takes place beyond the burner duct port in the furnace work chamber. Further oxidation of the unburned fuel particles exiting the burner is termed "residual-combustion" and equates to a degree of inefficiency. The negative resultant aspects following initial combustion in the burner effects the reformulation of unburned hydrocarbons having a higher ratio of carbon to hydrogen, an added detriment to the further completion of combustion. In order to finalize combustion, excessive amounts of combustion air must be introduced into the work chamber and various methods of under/over firing with gaseous fuels must be utilized to effect "reburn." This results in over-voluminous, inefficient and high cost boiler structures.

Past attempts by various firms knowledgeable in the art of thermochemical combustion to develop a combustor designed to complete all oxidizing rate-reactions have failed. During the 1980s the DOE funded millions of dollars to such projects. Operationally, the then designed combustors thermochemically failed to totally oxidize the carbonic elements. This resulted in a graphitic "char" formation causing clogging and eventual shutdown of the process.

Present firing combustion processes also exhibit post combustion problems which adversely affect the environment. Pollutants formed by sulfurous compounds and nitrous oxides and particulates, unless treated by expensive control systems, typically result from presently utilized combustion processes. A more advanced thermotechnical method for the oxidative combustion of hydrocarbons is desirable in order to eliminate or reduce problems associated with these pollutants.

DISCLOSURE OF THE INVENTION

The present invention provides a new and improved thermotechnology for the design of a combustor for use in, for example, steam generation in the boiler of a utility power plant. The disclosed Entropic Reactor-Combustor (ER-C) structure includes a reactor chamber, combustion chamber, and discharge chamber serially connected along a central axis.

In one preferred embodiment, the structure is formed as a single-cell entropic-reactor combustor (ER-C). In this embodiment, each chamber is made of a high temperature and corrosion resistant material such as a refractory/ceramic material. These refractory chambers define, respectively, a reactor zone, combustion zone, and discharge zone that extend through the refractory.

According to an illustrated embodiment of the invention, the combustion chamber comprises a venturi and the discharge chamber comprises a diverging nozzle. The single-cell ER-C includes a ceramic baffle insert that is concentrically disposed within the forward end of the reactor chamber. According to the invention, the baffle defines at

2
least one coal-gas passage extending longitudinally through the baffle and includes means for communicating an air-fuel mixture to the reactor zone. A reactor core tube, made of a refractory material, is sealingly engaged by the baffle. The core of the tube is in fluid communication with the coal-gas passage. The tube extends longitudinally through a portion of the reactor zone and terminates into the combustion zone. The reactor core tube communicates a coal-gas mixture from the coal-gas passage to the combustion zone. Means are provided for burning the air-fuel mixture in the reactor zone thereby heating the reactor core tube. The coal-gas mixture passing through the reactor core tube is thereby heated by conduction through the tube before entry into the combustion zone.

5
10
15
20
25
By irradiating the coal-gas mixture with heat energy the volumetric specific heat of the mixture is substantially raised. It is believed that this irradiation (which may be termed photolytic irradiation) ionizes the coal molecule and causes a debonding of its molecular structure. A molecular reformation of the coal and gas takes place that creates a new fuel mixture before the mixture is discharged from the reactor core tube. This restructuring of the coal-gas mixture effects a more effective and efficient burning upon combustion in the combustion chamber so that carbon by-products or graphitic build-up in the work chamber is substantially reduced or eliminated.

30
35
According to a feature of the invention, the air fuel mixture is communicated by means of an array of fuel burner ducts spaced from and disposed around the coal-gas passage, and extending longitudinally through the ceramic baffle insert. Disposed around each fuel burner duct is an array of air supply ducts extending longitudinally through the ceramic baffle insert.

40
45
According to another feature of the invention, the combustion chamber includes a plurality combustion air supply pipes extending radially through the chamber and terminating into the combustion zone. The air supply pipes are equally spaced apart around the periphery of the combustion chamber. There are an even quantity of air supply pipes so that any pipe in the array is diagonally opposed from another pipe in the array.

50
55
In another preferred embodiment, the entropic reactor combustor (ER-C) comprises a plurality of cells that are used to achieve the desired amount of volumetric specific heat. The design of the reactor chamber is based on an array of planetarily positioned unitized cells. The reactor chamber comprises a ceramic baffle in concentric relation to the reactor core chamber. Extending longitudinally through the baffle, and spaced a distance from the reactor core center, is a first array of integrated ceramic entropic fuel tubes, or ducts, disposed on a first inner radius and a second array of relatively larger ceramic tubes, or ducts, disposed on a larger second radius. Interposed between the first and second radially disposed ducts is an array of corresponding cavity ducts, or gaps, which form a series of interspatial reactor core cells, or a continuous planetary circumferential reactor chamber.

60
A fuel mixture, such as pulverized coal and methane gas, is dispensed into the interspatial reactor core chamber cells through a series of pulverized coal/gas supply nozzles attached to the ends of the reactor core chamber cells. An entropic fuel, such as methane gas, and combustion air are combined in the first and second array of entropic fuel ducts through a series of air/gas mix supply nozzles attached to the ends of the tubes. The air/gas mixture, when burned in the multiple series of entropic fuel ducts, generates intense heat

5,950,547

3

required for conductivity through the walls of the entropic fuel ducts enclosing the interspatial reactor core chamber. The conducted source of continuous heat from the outer surface of the reactor core chamber is radiated to the inner surface of the reactor core to heat the pulverized coal/gas fuel mixture during passage through the reactor core chamber.

It is believed that in the disclosed apparatus the pulverized coal particles are initially subject to a sufficiently powerful thermallytically induced radiation to degradatively decompose the molecular structure of the pulverized coal particles. The thermalytic process maximizes the entropy, and therefore, increases the internal electrostatic energy of the coal molecule. During further passage through the interspatial reactor core chamber the irradiative exposure causes critical phase changes, promoting a vaporous/gaseous state. Concurrently, additional rapid operatives promoted by ionization and radicalization of the coal molecules effect requisite molecular reformations critical to subsequent detonative-oxidation of all carbonic elements of the coal particle in the downstream ER-C combustion chamber.

Unlike presently utilized conventional flame combustion devices or coal-firing systems, the ER-C thermal technology maximizes thermoflux and specific heats beyond the capability and efficiency of any existing flame syndrome burner. It is believed that, unlike existing industrial or utility power plants having lengthy time sequences for burning fuels by flame combustion, the ER-C process develops improved thermal efficiencies at lower costs. The ER-C substantially averts the problems involving the formation of flame cores resulting from reformed hydrocarbons having a higher ratio of carbon to hydrogen. Flame cores typically result in an undesirable graphitic phase blocking char formation. The high temperature reactions developed by the ER-C act to vaporize the inclusive inert minerals and promote further chemisms to atomize any potentially present tars/chars to a gaseous state.

According to another feature of the invention, the ER-C, when utilized with catalytic additives, can convert pollutant by-products, such as sulfur compounds and nitrous oxides into inert, stable compounds. Consequently, the post combustion and stack emissions control costs born by fossil burning plants operated by coal firing may be substantially reduced.

According to yet another feature of the invention, insulation is disposed around the periphery of the refractory material.

Additional features of the invention will become apparent and a fuller understanding obtained by reading the following detailed description made in connection with the accompanying drawings.

BRIEF DESCRIPTION OF THE DRAWINGS

FIG. 1 is a section elevational view of a single cell entropic reactor combustor showing reactor, combustion, and discharge zones.

FIG. 2 is a section view of the FIG. 1 single cell entropic reactor combustor as seen from the plane 2—2 in FIG. 1 showing an array of air and fuel ducts.

FIG. 3 is a broken section elevational view of an alternative embodiment of the single cell entropic reactor combustor showing a diverging discharge nozzle.

FIG. 4 is an end elevation view of an entropic reactor combustor constructed in accordance with the present invention.

4

FIG. 5 is a section view of the FIG. 4 entropic reactor combustor as seen from the plane 5—5 in FIG. 4 showing first and second array ducts.

FIG. 6 is a section view of the FIG. 4 entropic reactor combustor as seen from the plane 6—6 in FIG. 4 showing an interspatial reactor chamber.

BEST MODE FOR PRACTICING THE INVENTION

FIGS. 1 through 3 illustrate the overall construction of a "single-cell" Entropic Reactor Combustor (single-cell ER-C) 10. As shown in FIG. 2, the single-cell ER-C 10 includes a reactor chamber refractory 14, combustion chamber refractory 16, and discharge chamber refractory 18 connected in series and defining, respectively, a reactor chamber zone 14a, combustion chamber zone 16a and discharge chamber zone 18a. The combustion chamber refractory 16 includes a venturi passage defined by an inner wall 22 of the combustion chamber refractory 16. As shown in FIGS. 2 and 3, the discharge chamber zone 18a may comprise a uniform cylindrical chamber or a diverging nozzle. Disposed around the periphery of each refractory chamber 14, 16, 18, is a high temperature insulation material 15, 17, 19, respectively, and a combustor support housing 20 connected to a end plate flange 23. In concentric relation to the three chambers 14, 16, 18 is a ceramic baffle insert 30 which extends through an opening 101 in the end plate flange 23 and a reactor core tube 84. An outer wall 34 of the ceramic baffle insert 30 sealingly engages the forward end of an inner wall 202 of the reactor chamber 14. The reactor core tube 84 extends substantially the length of the reactor chamber zone 14a whereby one end of the reactor core tube 84 is sealingly engaged by a recess 39 in the ceramic baffle insert 30 and the other end is supported by a ceramic tube support 26 and terminates into the combustion chamber zone 16a of the single-cell ER-C 10.

As shown in FIGS. 1 and 2 of the disclosed embodiment, the ceramic baffle insert 30 defines an array of entropic fuel burner ducts or pipes 64 and an array of air supply ducts 65 that are disposed around each fuel burner duct 64. The fuel burner ducts 64 and air supply ducts 65 extend longitudinally through the ceramic baffle insert 30 and terminate into the reactor chamber zone 14a (as shown in FIG. 1). In the disclosed embodiment, there are five equally spaced fuel burner pipes 64 disposed on a radius r, and six equally spaced air supply ducts 65 surrounding each fuel burner pipe 64.

A flanged combustion air chamber 110 is mounted to the end plate flange 23 by a plurality of fasteners or welds. The air chamber 110 allows combustion air to enter each air supply duct 65 at substantially the same volumetric flow rate and pressure. The fuel burner pipes 64 extend rearwardly through the air chamber 110 and are connected to an external entropic fuel supply source (not shown). Conventional sealing methods can be used to seal the interface between the fuel burner ducts 64 and the air chamber 110.

In the disclosed embodiment, an entropic fuel, such as methane, and combustion air are entrained to burners and the products of combustion are routed through the reactor chamber zone 14a. Conventional fuel burners (not shown) initiate and maintain the necessary pyrolytics for the supply of heat to the reactor core tube 84. The burning of the entropic fuel in the reactor chamber zone 14a generates intense pyrolytic source heat for conduction through the wall of the reactor core tube 84.

The ceramic baffle insert 30 further defines a pulverized coal/gas supply nozzle 85 which is in fluid communication

5.950,547

5

with the reactor core tube 84 and a pulverized coal/gas supply passage 86 connected to an external coal/gas flow control source (not shown). According to the invention, a gas, such as methane, and pulverized coal particles are dispensed into the reactor-core tube 84 through the pulverized coal/gas supply nozzle 85.

The reactor chamber 14 acts as a molecular reactor. The intense heat from the burning methane/air mixture in the reactor chamber zone 14a pyrolytically heats the reactor core tube 84. The heated reactor core tube 84, in turn, photolytically heats the pulverized coal/gas fuel mixture flowing through the reactor core 84. In effect, the chemisms that take place in the reactor core 84 radicalize the methane gas and pulverized coal. The coal particles and gas are irradiated with high energy photons within the reactor core tube 84, thereby substantially raising the specific heat of the coal/gas fuel mixture. The photons reach an energy equal to or higher than that of an electron, which causes electrons to be continually emitted. It is believed that this photolytic irradiation ionizes, or degrades, the coal molecule, and causes a debonding of its molecular structure. The gas has a hydrogenolysis effect on the pulverized coal. In other words, two hydrogen atoms are freed from the methane gas molecule, and carbon atoms from the pulverized coal bond to these two freed hydrogen atoms. For this reason, it is necessary that the gas have a sufficient amount of hydrogen to degrade the coal molecule. The gas selected should preferably have a high hydrogen to carbon ratio as in, for example, methane gas (CH₄). It is also believed that sublimation takes place during passage of the pulverized coal/gas fuel mixture through the reactor core tube 84; that is, the irradiative exposure causes a phase change in the pulverized coal/gas fuel mixture to a vaporous/gaseous state. The new fuel comprises a new group of combustible chemisms that is in the form of a vapor upon discharge from the reactor chamber 14.

Upon entry into the combustion chamber zone 16a, the new fuel undergoes detonative oxidation combustion. In the preferred and illustrated embodiment, the oxidizing media used to oxidize the new fuel flows perpendicular to the path of the new fuel. As shown in FIGS. 1 and 2, a plurality of combustion air supply pipes 54 extend radially inward through the combustion chamber refractory 16 and terminate into the combustion chamber zone 16a via respective air inlet openings 56 defined by the inside wall 22 of the combustion chamber refractory 16. The air supply pipes 54 are in communication with a combustion air manifold 52 connected to a combustion air supply source (not shown). In the disclosed embodiment, the air supply pipes 54 are equally spaced apart to form a planetary spoked pattern 55. The air supply pipes 54 are positioned so that the flow of combustion air into the combustion chamber zone 16a is perpendicular to the flow of the pulverized coal/gas fuel mixture discharged from the reactor core tube 84. As shown in FIG. 1, an even amount of air supply pipes 54 is preferably used so that flow from one air supply pipe 54 collides with flow from its opposing air supply pipe 54. It is believed that the use of counterflow directed air supply pipes 54 facilitates turbulence in the combustion chamber zone 16a and substantially promotes uniform and instant exposure of the surface areas of coal particles to oxidative rate reactions.

The present invention provides significant advantages over conventional burner-type systems. It is believed that by hydrogenating the coal molecule before combustion, that the build-up of unburned hydrocarbons that is found in flame combustion or coal-firing systems is substantially reduced.

6

According to the present invention, the pulverized coal is treated in such a manner that there is no substantial development of double bond carbon elements to produce a graphite. As alluded to above, it is believed that the carbon adheres to the free hydrogen and then becomes a liquid that is later vaporized. Consequently, the ER-C 10 substantially prevents reformed hydrocarbons and graphitic formation that is characteristic of a conventional burner or flame-type system.

A bench test model was constructed and tested to demonstrate the principles of the invention with the following dimensions and operating parameters. The reactor chamber zone 14a has a diameter of 10.0" (25.0 cm), length 24.0" (60.0 cm), circumference 31.42" (78.54 cm), and volume 1700"³ (26,800 cm³). The reactor core ceramic tube 84 has a diameter of 3.0" (7.5 cm), length 24.0" (60.0 cm), circumference 9.42" (23.6 cm), and volume 168.0"³ (2652 cm³). The combustor chamber zone 16a has a diameter of 8.0" (20.0 cm), length 10.0" (25.0 cm), circumference 25.1" (62.8 cm), and volume 510"³ (8000 cm³).

The ceramic baffle insert includes an array of five entropic fuel burner ducts 65, each duct having a diameter of 3/8 inches. The volumetric flow rate of methane gas through each duct 65 is 371 ft³/h (10.5 m³/h). Combustion-air is communicated to the reactor core chamber 14a via an array of five air supply ducts 65 that are disposed around each fuel burner duct 64. Each air supply duct 65 is preferably 3/8 inches in diameter. There are a total of 25 air supply ducts 65. The volumetric flow rate of the combustion air is about 3175 ft³/h (90 m³/h). The ratio of the circumferential surface area of the refractory reactor chamber zone 14a to the volume of the reactor chamber zone 14a is 1.0/2.5 (based on 4712 cm²/26800 cm³, or 754"²/1700"³).

The mass flow rate of the pulverized coal particles dispensed into the reactor core tube 84 through the pulverized coal/gas supply passage 86 and nozzle 85 is about 80 lb/h (36 kg/h, or 10 grams/s). The volumetric flow rate of the methane gas through the passage 86 and nozzle 85 is 380 ft³/h (10.8 m³/h, or 3000 cm³/s). The resulting ratio of methane gas to pulverized coal is 300 cm³/s gas to 1.0 gram/s pulverized coal. A preferred diameter of the pulverized coal/gas supply passage is 1.15" (3.125 cm). The circumferential surface area of the reactor core tube 84 (based on the internal diameter) is 226"² (1415 cm²). The ratio of the circumferential surface area of the reactor core tube 84 to the core volume of the reactor core tube is 226"²/168"³ (1415 cm²/2640 cm³).

The ER-C 10 includes four equally spaced radially positioned combustion air supply pipes 54 for directing air flow perpendicular to the flow of the reformulated pulverized coal/gas fuel expelled from the reactor core tube 84. Each pipe 54 has a diameter of 2.0" (5.0 cm). The combustion air flow rate through each air supply pipe 54 is about 360 m³/h (90 m³/h). The venturi defined by the wall 22 of the combustion chamber refractory 16 is approximately a 25 cm:20 cm reduction in cross-sectional area. The volumetric flow rate of the pulverized coal/gas fuel mixture expelled by the nozzle 85 enters the combustor combustion chamber zone 16a at approximately 13,000 cm³/s (46.8 m³/h).

The temperature in the reactor chamber zone 14a was approximately 3000-3200 degrees F. The temperature realized by the coal/gas fuel mixture in the combustion chamber zone 16a was approximately 2400-2600 degrees F. The temperature of the combustor chamber was about 3300-3500 degrees F. The power output realized was approximately 360,000 KCal/h (1,500,000 Btu/h).



5.950.547

7

Referring now to FIGS. 4 through 6, another preferred embodiment is illustrated showing the overall construction of a "multi-cell" Entropic Reactor-Combustor (ER-C) 310 for converting chemical energy of a fossil fuel to thermal energy for use in an industrial or utility power generation plant. As shown in FIG. 5, the multi-cell ER-C 310 includes a reactor chamber refractory 314, combustion chamber refractory 316, and discharge chamber refractory 318 connected in series and encased in a combustor support housing 320 with a end plate flange 323. The chambers 314, 316, 318 define, respectively, a reactor chamber zone 314a, combustion chamber zone 316a, and discharge chamber zone 318a. In concentric relation to the three chambers 314, 316, 318 is an alloy tube 325 extending through the reactor chamber zone 314a to the entry of the combustion chamber zone 316a which defines an inner oxidizing media or combustion-air manifold 322 for controlling flow of oxygen or air to the combustion chamber zone 316a. An outer ceramic baffle insert 330 and an inner ceramic baffle insert 331 are circumferentially positioned between the alloy tube 325 and the reactor chamber 314. In communication with the inner air manifold 322 are a plurality of radial air supply ducts 340 extending outward to openings 341 in the alloy tube 325. As shown in FIG. 4, an outer oxidizing media or combustion-air manifold 352 also has a plurality of radial air supply ducts 354 extending inward to openings 356 in the combustion chamber 316.

The inner ceramic baffle insert 331 defines an array 360 of integrated entropic fuel burner ducts 364 disposed on a first radius R1 and the outer ceramic baffle insert 330 defines an array 370 of larger entropic fuel burner ducts 374 disposed on a larger second radius R2. Between the first and second radially disposed entropic fuel ducts 364, 374 is an array 80 of configured cells 384 disposed on an intermediate radius R. The open spaces or voids of the cells 384 form a continuous circumferential chamber, or an interspatial reactor core 385.

A generally circular baffle support flange-plate 410 is mounted to the end plate flange 323 by a plurality of bolts 402. The baffle support plate 410 is further connected to an interior baffle support plate 400 having an opening 401. The alloy tube 325 and the inner combustion-air manifold 322 extend through the opening 401 to an external air supply header (not shown).

FIG. 5 shows a section view of the ceramic entropic fuel ducts 364, 374. At their upstream end 361, 371 the ducts 364, 374 begin at the baffle support plates 400, 410 and are in communication with a plurality of entropic fuel supply nozzles 450 connected to an external fuel supply source and a combustion air ratioing device (not shown). The radially disposed ducts 364, 374 extend the length of the ceramic baffle inserts 330, 331 to outlets 362, 372, respectively, adjacent the entrance of the combustion chamber zone 316a.

FIG. 6 shows a section view of the array 380 of the reactor-core cells 384 which form the circumferentially configured reactor core chamber 385. At their upstream end 381 the cells 384 begin at the baffle support plates 400, 410 and are in communication with a plurality of pulverized coal/gas fuel mixture supply nozzles 460 which are connected to an external fuel flow control source (not shown). The interspatial reactor core 385 extends the length of the ceramic baffle inserts 330, 331 and terminates at a mix/ignition zone 382 located near the entrance of the combustion chamber zone 316a. A fossil fuel, such as pulverized coal, and a gas, such as methane, are dispensed into the interspatial reactor chamber 385 through the fuel supply nozzles 460.

diff
from
here
on

8

In the disclosed embodiment, an entropic fuel, such as methane, and combustion air are entrained to burners and the products of combustion are routed through the first and second arrays 360, 370 of the entropic fuel ducts 364, 374. Conventional fuel burners (not shown in detail) initiate and maintain the necessary pyrolytics for the supply of heat to the multiple ducts 364, 374.

Referring to FIG. 4, the outer combustion-air manifold 352 supplies oxygen or air to a plurality of radially extending air supply ducts 354 and inward to air inlet openings 356 in the combustion chamber 316 (as shown in FIGS. 5 and 6). Combustion air is also simultaneously dispensed from the inner combustion-air manifold 322 outward to a plurality of radially extending air supply ducts 340 and air inlet openings 341 in the combustion chamber 316.

The use of a multi-cell ER-C 310 for fossil fuel provides several advantages over conventional burner-type systems. The burning process of entropic fuel in the ducts 364, 374 of the ceramic baffle inserts 330, 331 generates intense pyrolytic source heat for conduction through duct walls 368, 378 of the first and second arrays 360, 370 of the entropic fuel ducts 364, 374. The reactor chamber 385 utilizes an array 380 of unitized "cells" 384 which bound the interspatial reactor chamber 385. It is believed that the pulverized coal/gas fuel mixture, upon entry into the cells 384, undergoes a mechanical procedure to disperse and diffuse the pulverized coal/gas fuel mixture to effect a reduction to a decimated 1/10000 of original volumetric mass.

In the preferred embodiment, the outer air supply or oxidizing media ducts 354 are equally spaced apart by an angle alpha to form a planetary spoked pattern 355. The inner air supply or oxidizing media ducts 340, which are equal in number to the outer air supply ducts 354, are also equally spaced apart by an angle alpha on a corresponding planetary spoked pattern 344. As shown in FIG. 4, the convergently spoked pattern 355 is relatively offset from the divergently spoked pattern 344 by an angle of about 1/2 alpha.

It is believed that the use of the radially positioned inner/outer counterflow directed air supply ducts 340, 354 in offset relation facilitates turbulence near the mix/ignition zone 382 in the combustion chamber 316 and results in diffusivity to maximize the dispersive mixing and particle distribution of the reactives, air and fuel, in the combustion chamber 316. As a result, the heated pulverized coal/gas fuel mixture, or newly created fuel mixture, is uniformly and instantly exposed to the oxidative reaction. Pyrolytics effect the reaction-kinetics for reducing the size of the pulverized coal/gas mixture within the interspatial reactor chamber 385 with the further desirable aspect that the rate-reactions will increase as the molecular weight of the pulverized coal decreases.

The combustion technology of the ER-C 310 promotes a detonative-oxidation of the newly created pulverized coal/gas fuel mixture to entropically maximize the internal energy, or electrostatic potential, of the fuel molecule. The molecular structure of the pulverized coal and methane gas relative to the induced pyrolytics by the ER-C core 385 is electronically restructured. The resultant molecular reformations effect the critical chemistries for promoting positive phase changes of the coal molecule from solid to liquid to gas.

Like the single-cell ER-C 10 disclosed hereinabove, the multi-cell ER-C 310 utilizes the aspects of photolysis. The high density radiation in the interspatial reactor chamber 385 effects a radical restructuring of the reactants (for example, pulverized coal and methane) in a period of

5.950.547

microseconds to a higher disbonding energy level. further maximizing the thermionically/plasmonically created excitation state of photons and electrons. These reactions promote molecular decomposition, degradation, radicalization, ionization and atomization of the pulverized coal.

The rapid ion-molecular rate-reactions effected by the multi-cell ER-C 310 maximize thermoflux and specific heats beyond the limit and efficiency of any present flame-syndrome burner system. Unlike the lengthy time sequences for the combustion of fuels experienced by existing deflagration devices, the ER-C 310 develops work chamber temperatures in excess of those presently attained by any industrial or utility plant, and at a lower cost. Averted by the ER-C 310 are the formation of flame cores resulting from reformed hydrocarbons having a higher ratio of carbon to hydrogen. The present invention eliminates or substantially reduces blocking char forming chemisms.

The multi-cell ER-C 310, in combination with conventional catalytic additives, can effect chemisms to plasmonically combine sulfurous and nitrous pollutants and substantially convert them into inert stable compounds conforming to EPA mandated specifications. Eliminating this high price for emission control costs would reflect a higher profit margin for industrial or utility plant operations.

FIG. 5 shows an entropic-reactor combustor 10 incorporating the principles of the present invention. The size, shape, quantity, and configurative spacing of the entropic fuel ducts 364, 374 geometrically defines the corresponding cells 384 which structurally equate to the resultant interspatial reactor chamber 385. Most preferably, the first array 360 includes twenty equally spaced ducts 364 disposed on a radius of approximately 32.0 cm (12.5 inches) to form a planetary pattern 366. The second array 370 includes twenty equally spaced ducts 374 disposed on a radius of approximately 49.3 cm (19.4 inches) to form an outer planetary pattern 377. Disposed approximately at the center point of the ducts 364, 374 initiating near the end plate flange 323 are entropic fuel nozzles 450. In the preferred embodiment the planetary patterns 366, 377 have coincident concentric centers C and about equal angular displacements beta, where beta is approximately 18 degrees.

According to the invention, the interspatial reactor chamber 385 preferably includes an array 380 of twenty equally spaced gaps or cells 384 disposed on a radius of approximately 39.6 cm (15.4 inches) to form a circumferential planetary pattern 388. The planetary pattern 388 is offset from the planetary patterns 366, 377 by an angle of about 1/2 beta, or approximately 9 degrees. Disposed approximately at the center of each of the reactor chamber cells 384 are fossil fuel nozzles 160.

In the disclosed embodiment, the heat conducted through the walls 368, 378 of the ducts 364, 374 relates to the composition and thickness. A preferred thickness of approximately 30 mm (1.25 inches) would effect an optimum degree of heat transfer for effecting the requisite amount of radiant heat, or photolysis, in the interspatial reactor chamber 385.

Referring now to FIG. 5 of the preferred embodiment, it is seen that the refractory chambers 314, 316, 318 may comprise a concentrically unitized structure. The outer ceramic baffle 330 preferably comprises a generally circular insert having an external wall 334 which engages an internal wall 502 and outlet port 512 of the reactor chamber refractory 314. An internal wall 335 of the inner ceramic baffle 331 engages an external wall 501 and outlet port 511 of the alloy tube 325. The interfaces 525 may be formed with any ceramic material and bonding mortar.

As shown in FIGS. 5 and 6, the resident time of thermal exposure to the pulverized coal/gas fuel mixture developed in the reactor chamber cells 384 relates to the length L of the ceramic baffles 330, 331 and the flow velocity of the pulverized coal/gas fuel mixture. In the preferred and illustrated embodiment, the length L is approximately 60 cm (24.0 inches). The velocity of the pulverized coal/gas fuel mixture through the interspatial reactor chamber cells 385 is approximately 1.0 meter (3.3 feet) per second.

According to the invention, oxidizing media or combustion-air is introduced in the combustion chamber zone 316a through the inner array of air supply ducts 340 from the inner combustion-air manifold 322. Combustion-air is simultaneously introduced in the combustion chamber zone 316a through the outer array of air supply ducts 354 from the outer combustion air manifold 352. The relative volumetric air flows from the outer/inner manifolds 352, 322 can be about: 1.0 cubic meter (35.3 cubic feet) per second/ 0.66 cubic meter (23.3 cubic ft) per second.

Although the invention has been described with a certain degree of particularity it should be understood that those skilled in the art can make various changes to it without departing from the spirit or scope of the invention as hereinafter claimed.

I claim:

1. A coal combustor for combustion of coal in fossil burning plants, comprising:

- a) a refractory including a reactor chamber, combustion chamber, and discharge chamber serially connected along a central longitudinal axis; said chambers defining, respectively a reactor zone, combustion zone, and discharge zone extending through said refractory;
- b) a ceramic baffle insert concentrically disposed within said reactor chamber;
- c) said baffle insert defining at least one coal-gas passage;
- d) a reactor core tube scalingly engaged by said baffle insert and in communication with said coal-gas passage; said reactor core tube extending longitudinally through a portion of said reactor zone and terminating in said combustion zone, said reactor core tube operative to communicate a coal-gas mixture from said coal-gas passage to said combustion zone;
- e) means for communicating an air-fuel mixture to said reactor zone including an array of fuel burner ducts spaced from, and disposed around, said coal-gas passage and extending longitudinally through said ceramic baffle insert;
- f) means for burning said air-fuel mixture in said reactor zone thereby heating said reactor core tube and said coal-gas mixture passing through said core tube, by conduction, before entry into said combustion zone.

2. The combustor of claim 1, wherein said communicating means further includes an array of air supply ducts disposed around each burner duct in said array of fuel burner ducts and extending longitudinally through said ceramic baffle insert.

3. The combustor of claim 1, wherein said coal-gas mixture comprises pulverized coal and methane.

4. A coal combustor for combustion of coal in fossil burning plants, comprising:

- a) a reactor chamber refractory, combustion chamber refractory, and discharge chamber refractory, serially connected, the centers of said refractories being disposed on a common longitudinal axis; said chambers defining, in serial communication, respectively, a reactor zone, combustion zone, and discharge zone;

CLAIMS

✓

IS THIS MODEL?

2 We don't INVENT OR INVENTOR DO WE OR?

5.950.547

11

- b) means for supplying combustion air to said combustion zone;
 - c) an inner refractory baffle insert extending along substantially the entire length of said reactor chamber refractory and having an exterior wall; said inner baffle insert concentric relative to said reactor chamber refractory and defining a first array of integrated fuel burner ducts extending longitudinally;
 - d) an outer refractory baffle insert extending along substantially the entire length of said reactor chamber refractory and having an interior wall and exterior wall; said outer baffle insert concentric relative to said reactor chamber refractory and positioned intermediate said reactor chamber refractory and said inner baffle insert and defining a second array of integrated fuel burner ducts extending longitudinally; said exterior wall of said outer baffle insert in sealing engagement with an interior wall of said reactor chamber refractory;
 - e) means for supplying an air-fuel mixture through said first and second arrays of fuel burner ducts;
 - f) an interspatial reactor chamber defined by said inner baffle insert exterior wall and said outer baffle insert interior wall;
 - g) means for supplying a coal-gas mixture through said interspatial reactor chamber;
 - h) means for burning said air-fuel mixture in said first and second arrays of fuel burner ducts, thereby heating said outer baffle insert interior wall and said inner baffle insert exterior wall and the coal-gas mixture passing through said reactor chamber.
5. The combustor of claim 4, wherein said combustion air supply means comprises an inner combustion air manifold.
6. The combustor of claim 5 wherein said inner combustion air manifold comprises an alloy tube concentric relative to said reactor chamber refractory and extending substantially the entire length of said reactor chamber refractory and said combustion chamber refractory; said alloy tube including a plurality of air supply conduits extending radially outwardly and terminating in said combustion zone.
7. The combustor of claim 6, wherein said combustion air supply means further comprises an outer combustion air manifold.
8. The combustor of claim 7, wherein said outer combustion air manifold defines a plurality of air supply conduits extending radially inwardly and terminating in said combustion zone.

12

9. The combustor of claim 8, wherein said outwardly extending air supply conduits are equal in quantity to said inwardly extending air supply conduits.
10. The combustor of claim 8, wherein said outwardly extending conduits are substantially equally spaced apart in a first radial plane and said inwardly extending conduits are substantially equally spaced apart in a second radial plane and said first plane offset from said second plane.
11. The combustor of claim 4, wherein said air-fuel mixture means comprises an air-fuel proportioning device in communication with a plurality of nozzles that supply said air-fuel mixture to said respective fuel burner ducts.
12. The combustor of claim 4, wherein said burning means comprises a burner disposed at an entrance end of each said respective fuel burner ducts for igniting and burning fuel.
13. The combustor of claim 4, wherein said fuel burner ducts are substantially circular in cross-section.
14. The combustor of claim 4, wherein said first array fuel burner ducts are equal in quantity to said second array fuel burner ducts.
15. The combustor of claim 14, wherein said second array fuel burner ducts are substantially equally angularly spaced apart and said first array fuel burner ducts are substantially equally angularly spaced apart and coincident to the angular spacing of said second array fuel burner ducts.
16. The combustor of claim 4, wherein said interspatial reactor chamber includes a plurality of interconnected cells that form a continuous circumferential gap intermediate said inner baffle insert exterior wall and said outer baffle insert interior wall and extending substantially the entire length of said reactor chamber refractory.
17. The combustor of claim 16, wherein said cells, said first array fuel burner ducts, and said second array fuel burner ducts are equal in quantity.
18. The combustor of claim 17, wherein said cells are substantially equally angularly spaced apart and relatively offset from said fuel burner ducts.
19. The combustor of claim 16, wherein said coal-gas supply means comprises a fuel flow control source in communication with a plurality of nozzles that supply said coal-gas mixture to said respective cells

* * * * *

EXHIBIT HOFFMAN&F.

B

(12) **United States Patent**
Wachendorfer

(10) **Patent No.:** **US 6,216,613 B1**
(45) **Date of Patent:** **Apr. 17, 2001**

(54) **COMBUSTION PROCESS**

(75) **Inventor:** Paul Wachendorfer, Carrollton, OH (US)

(73) **Assignee:** Theoretical Thermionics, Inc., McDonald, OH (US)

(*) **Notice:** Subject to any disclaimer, the term of this patent is extended or adjusted under 35 U.S.C. 154(b) by 0 days.

(21) **Appl. No.:** 09/348,128

(22) **Filed:** Jul. 2, 1999

Related U.S. Application Data

(62) Division of application No. 08/897,939, filed on Jul. 21, 1997.

(51) **Int. Cl.?** F23B 7/00

(52) **U.S. CL** 110/347; 110/262; 110/263; 110/342

(58) **Field of Search** 110/104 B, 260, 110/261, 262, 263, 264, 265, 266, 346, 347, 322, 323, 342

(56) **References Cited**

U.S. PATENT DOCUMENTS

792,667 * 6/1905 Rogers 110/347 X

1,560,076	*	11/1925	Gates	110/347
1,969,501	*	8/1934	Chapman	110/263
3,085,865	*	4/1963	Long et al.	110/261 X
4,574,711	*	3/1986	Christian	110/264
4,597,342	*	7/1986	Green et al.	110/347

* cited by examiner

Primary Examiner—Ira S. Lazarus

Assistant Examiner—Ljiljana V. Ciric

(74) *Attorney, Agent, or Firm*—Watts, Hoffmann, Fisher & Heinke Co.

(57) **ABSTRACT**

A process for solid fossil fuel oxidation that utilizes a refractory that defines a reactor core and a combustor chamber in serial communication. The reactor core is heated by burning an air fuel mixture external to the reactor core. A non-oxidizing gas/coal mixture is introduced into the reactor core where heat energy is transferred to the non-oxidizing gas/coal mixture so that the specific heat of the mixture is substantially raised. The non-oxidizing gas/coal mixture is discharged from the reactor core into the combustor chamber at which point an oxidizing medium such as air is introduced in order to instantly oxidize the heated non-oxidizing gas/coal mixture. The non-oxidizing gas may be a flammable gas, such as methane.

3 Claims, 4 Drawing Sheets

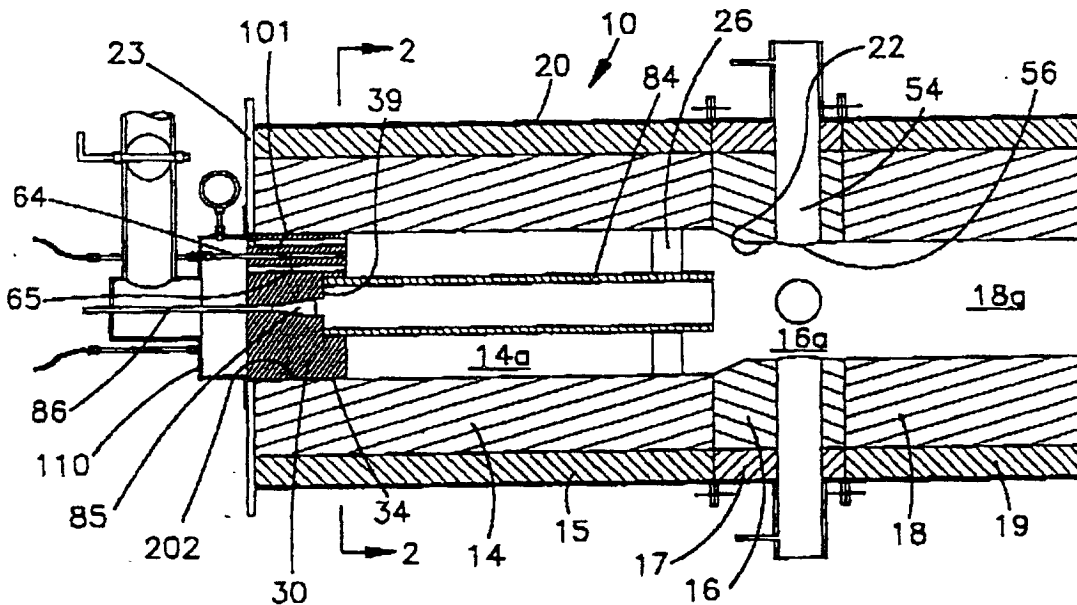

U.S. Patent

Apr. 17, 2001

Sheet 1 of 4

US 6,216,613 B1

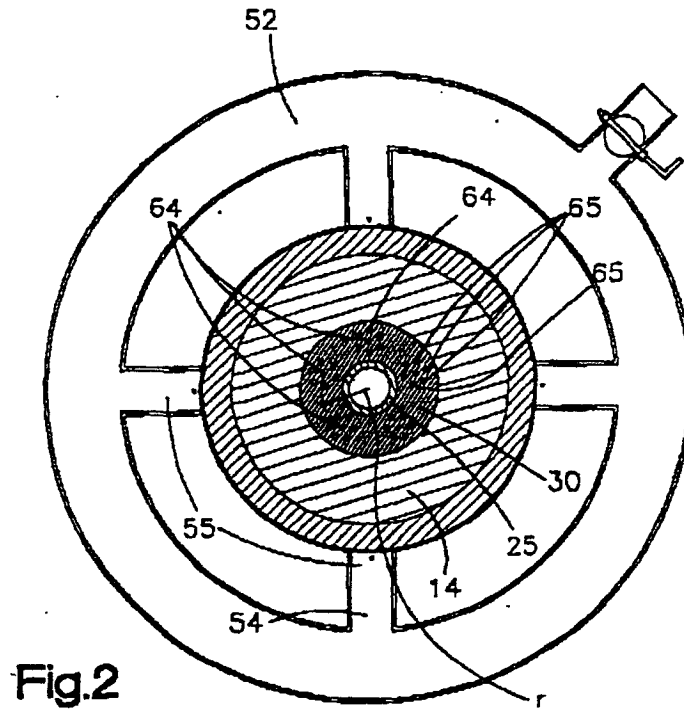
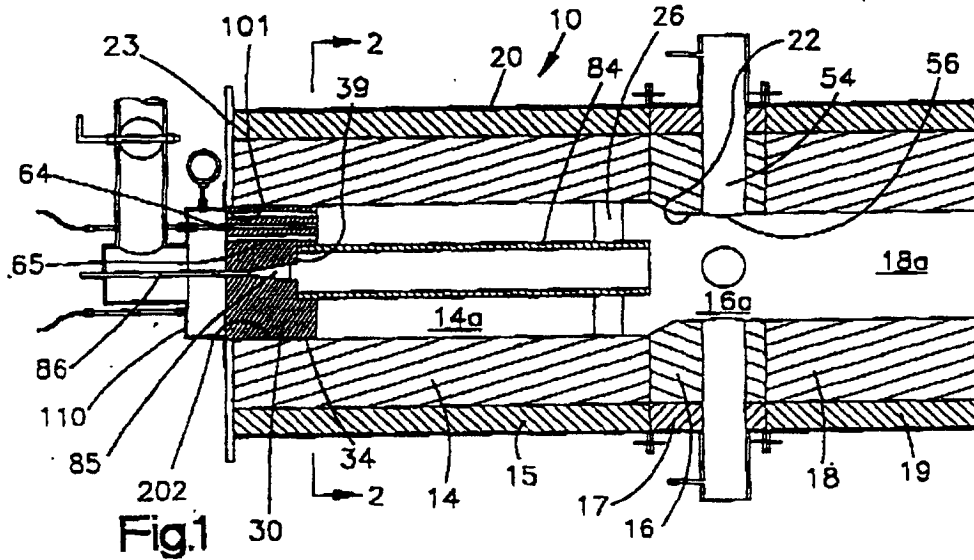

U.S. Patent

Apr. 17, 2001

Sheet 2 of 4

US 6,216,613 B1

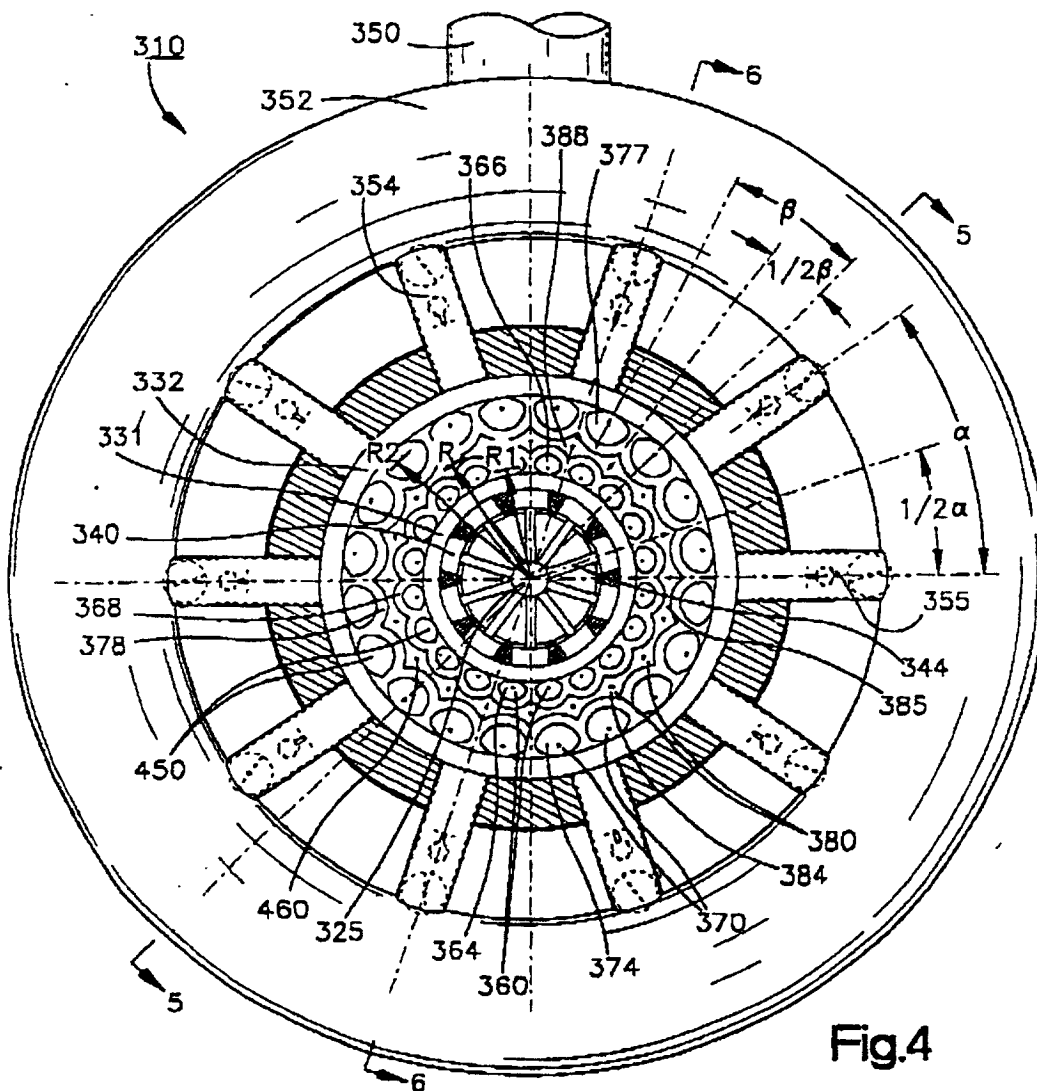
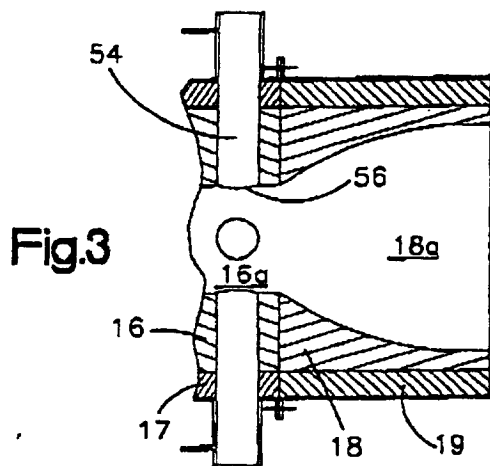

Fig. 4

U.S. Patent

Apr. 17, 2001

Sheet 3 of 4

US 6,216,613 B1

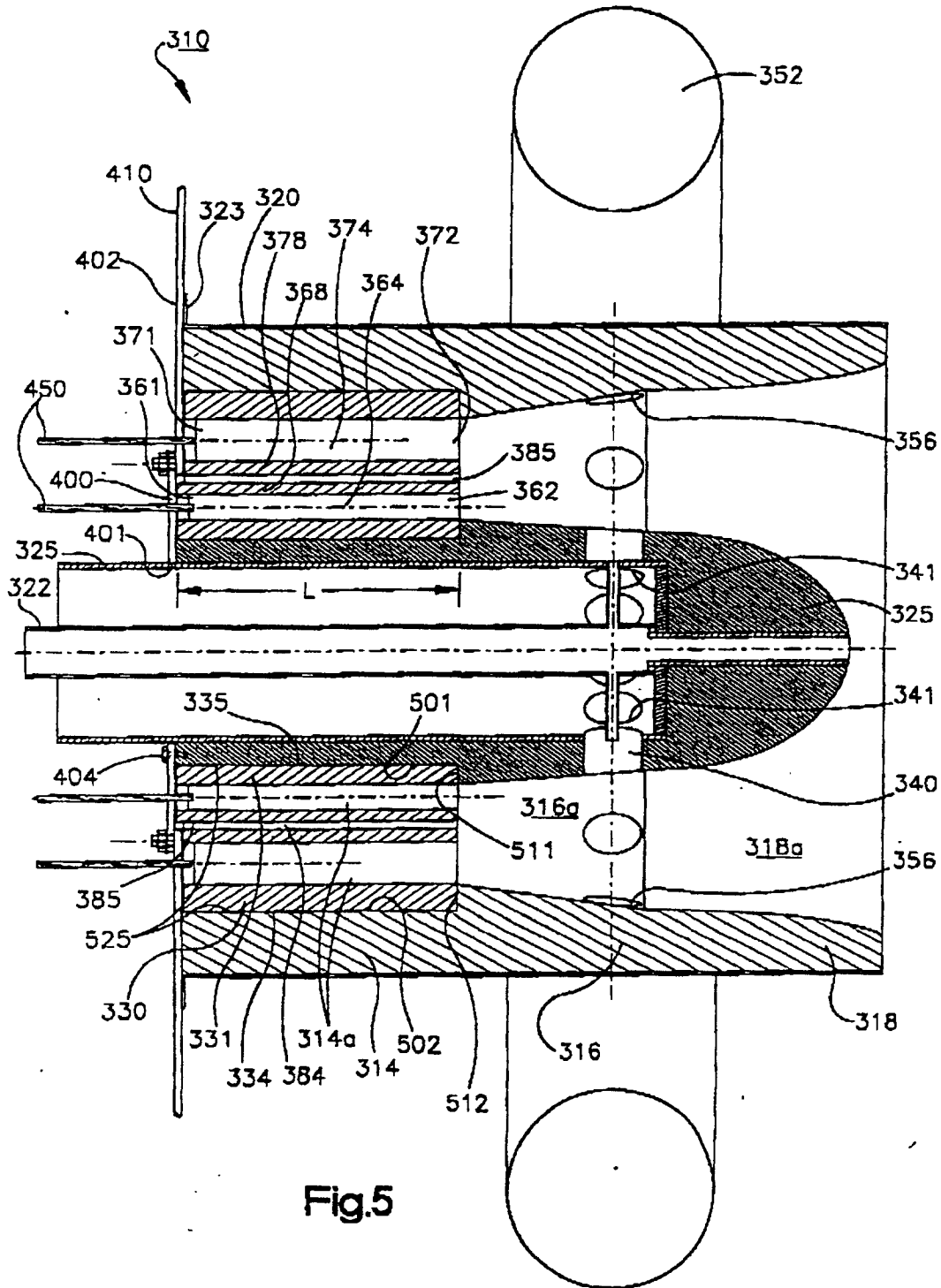

U.S. Patent

Apr. 17, 2001

Sheet 4 of 4

US 6,216,613 B1

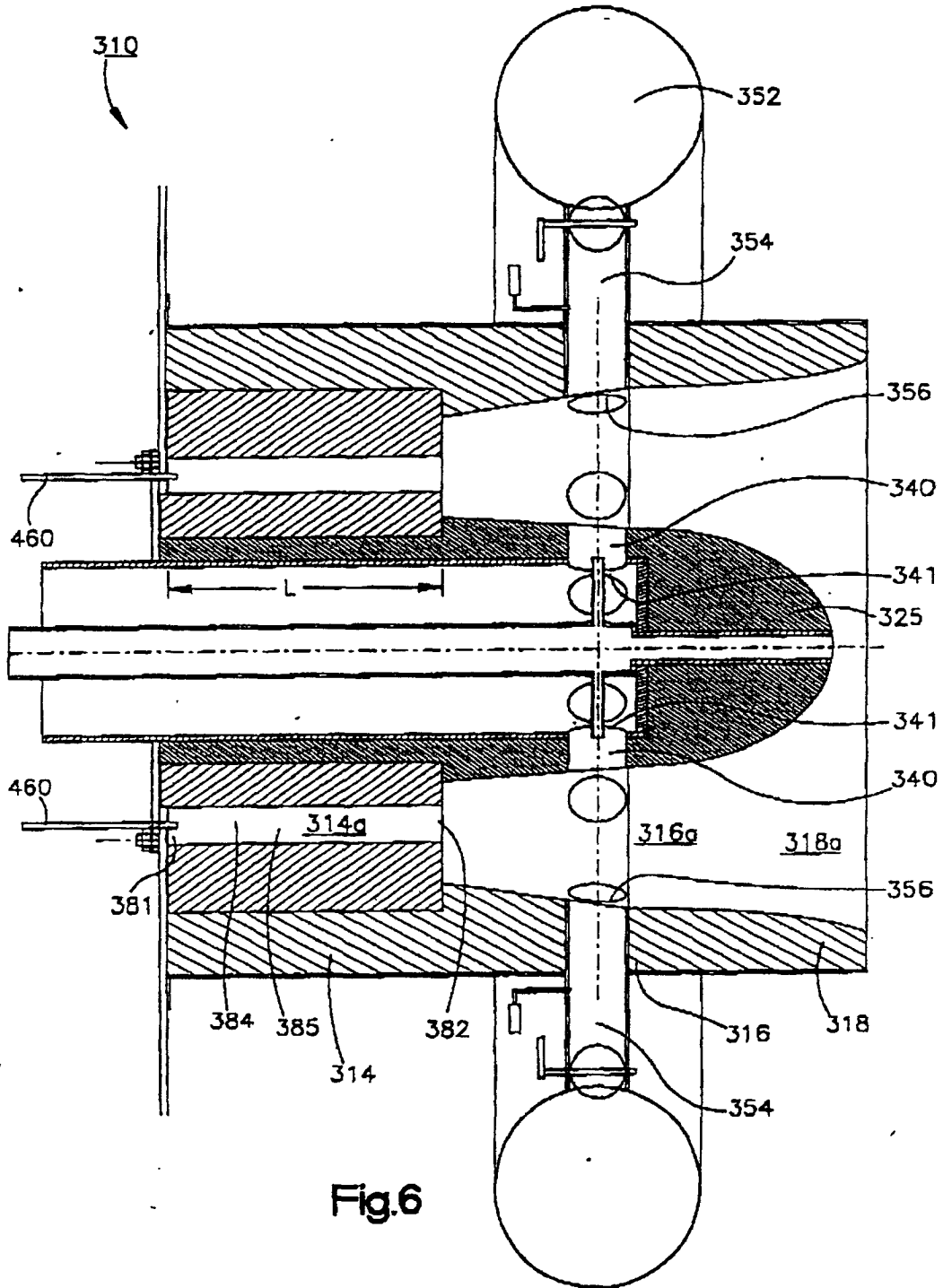

Fig.6

US 6,216,613 B1

1
COMBUSTION PROCESS

This is a Divisional application of application Ser. No. 08/897,939, filed on Jul. 21, 1997.

FIELD OF THE INVENTION

The present invention relates generally to a coal combustor and, more specifically, will be referred to as an entropic reactor for the combustion of coal in fossil burning plants, such as utility plants.

BACKGROUND ART

Most fossil burning plants, such as utility plants, presently utilize a burning or firing combustion process in which most of the thermochemical reaction takes place beyond the burner duct port in the furnace work chamber. Further oxidation of the unburned fuel particles exiting the burner is termed "residual-combustion" and equates to a degree of inefficiency. The negative resultant aspects following initial combustion in the burner effects the reformulation of unburned hydrocarbons having a higher ratio of carbon to hydrogen, an added detriment to the further completion of combustion. In order to finalize combustion, excessive amounts of combustion air must be introduced into the work chamber and various methods of under/over firing with gaseous fuels must be utilized to effect "reburn." This results in over-voluminous, inefficient and high cost boiler structures.

Past attempts by various firms knowledgeable in the art of thermochemical combustion to develop a combustor designed to complete all oxidizing rate-reactions have failed. During the 1980s the DOE funded millions of dollars to such projects. Operationally, the then designed combustors thermochemically failed to totally oxidize the carbonic elements. This resulted in a graphitic "char" formation causing clogging and eventual shutdown of the process.

Present firing combustion processes also exhibit post combustion problems which adversely affect the environment. Pollutants formed by sulfurous compounds and nitrous oxides and particulates, unless treated by expensive control systems, typically result from presently utilized combustion processes. A more advanced thermotechnical method for the oxidative combustion of hydrocarbons is desirable in order to eliminate or reduce problems associated with these pollutants.

DISCLOSURE OF THE INVENTION

The present invention provides a new and improved thermotechnology for the design of a combustor for use in, for example, steam generation in the boiler of a utility power plant. The disclosed Entropic Reactor-Combustor (ER-C) structure includes a reactor chamber, combustion chamber, and discharge chamber serially connected along a central axis.

In one preferred embodiment, the structure is formed as a single-cell entropic-reactor combustor (ER-C). In this embodiment, each chamber is made of a high temperature and corrosion resistant material such as a refractory/ceramic material. These refractory chambers define, respectively, a reactor zone, combustion zone, and discharge zone that extend through the refractory.

2

According to an illustrated embodiment of the invention, the combustion chamber comprises a venturi and the discharge chamber comprises a diverging nozzle. The single-cell ER-C includes a ceramic baffle insert that is concentrically disposed within the forward end of the reactor chamber. According to the invention, the baffle defines at least one coal-gas passage extending longitudinally through the baffle and includes means for communicating an air-fuel mixture to the reactor zone. A reactor core tube, made of a refractory material, is sealingly engaged by the baffle. The core of the tube is in fluid communication with the coal-gas passage. The tube extends longitudinally through a portion of the reactor zone and terminates into the combustion zone. The reactor core tube communicates a coal-gas mixture from the coal-gas passage to the combustion zone. Means are provided for burning the air-fuel mixture in the reactor zone thereby heating the reactor core tube. The coal-gas mixture passing through the reactor core tube is thereby heated by conduction through the tube before entry into the combustion zone.

By irradiating the coal-gas mixture with heat energy the volumetric specific heat of the mixture is substantially raised. It is believed that this irradiation (which may be termed photolytic irradiation) ionizes the coal molecule and causes a debonding of its molecular structure. A molecular reformulation of the coal and gas takes place that creates a new fuel mixture before the mixture is discharged from the reactor core tube. This restructuring of the coal-gas mixture effects a more effective and efficient burning upon combustion in the combustion chamber so that carbon by-products or graphitic build-up in the work chamber is substantially reduced or eliminated.

According to a feature of the invention, the air fuel mixture is communicated by means of an array of fuel burner ducts spaced from and disposed around the coal-gas passage, and extending longitudinally through the ceramic baffle insert. Disposed around each fuel burner duct is an array of air supply ducts extending longitudinally through the ceramic baffle insert.

According to another feature of the invention, the combustion chamber includes a plurality combustion air supply pipes extending radially through the chamber and terminating into the combustion zone. The air supply pipes are equally spaced apart around the periphery of the combustion chamber. There are an even quantity of air supply pipes so that any pipe in the array is diagonally opposed from another pipe in the array.

In another preferred embodiment, the entropic reactor combustor (ER-C) comprises a plurality of cells that are used to achieve the desired amount of volumetric specific heat. The design of the reactor chamber is based on an array of planetarily positioned unitized cells. The reactor chamber comprises a ceramic baffle in concentric relation to the reactor core chamber. Extending longitudinally through the baffle, and spaced a distance from the reactor core center, is a first array of integrated ceramic entropic fuel tubes, or ducts, disposed on a first inner radius and a second array of relatively larger ceramic tubes, or ducts, disposed on a larger second radius. Interposed between the first and second radially disposed ducts is an array of corresponding cavity ducts, or gaps, which form a series of interspatial reactor core cells, or a continuous planetary circumferential reactor chamber.

US 6,216,613 B1

3

A fuel mixture, such as pulverized coal and methane gas, is dispensed into the interspatial reactor core chamber cells through a series of pulverized coal/gas supply nozzles attached to the ends of the reactor core chamber cells. An entropic fuel, such as methane gas, and combustion air are combined in the first and second array of entropic fuel ducts through a series of air/gas mix supply nozzles attached to the ends of the tubes. The air/gas mixture, when burned in the multiple series of entropic fuel ducts, generates intense heat required for conductivity through the walls of the entropic fuel ducts enclosing the interspatial reactor core chamber. The conducted source of continuous heat from the outer surface of the reactor core chamber is radiated to the inner surface of the reactor core to heat the pulverized coal/gas fuel mixture during passage through the reactor core chamber.

It is believed that in the disclosed apparatus the pulverized coal particles are initially subject to a sufficiently powerful thermally induced radiation to degravitatively decompose the molecular structure of the pulverized coal particles. The thermalytic process maximizes the entropy, and therefore, increases the internal electrostatic energy of the coal molecule. During further passage through the interspatial reactor core chamber the irradiative exposure causes critical phase changes, promoting a vaporous/gaseous state. Concurrently, additional rapid operations promoted by ionization and radicalization of the coal molecules effect requisite molecular reformations critical to subsequent detonative-oxidation of all carbonic elements of the coal particle in the downstream ER-C combustion chamber.

Unlike presently utilized conventional flame combustion devices or coal-firing systems, the ER-C thermal technology maximizes thermoflux and specific heats beyond the capability and efficiency of any existing flame syndrome burner. It is believed that, unlike existing industrial or utility power plants having lengthy time sequences for burning fuels by flame combustion, the ER-C process develops improved thermal efficiencies at lower costs. The ER-C substantially averts the problems involving the formation of flame cores resulting from reformed hydrocarbons having a higher ratio of carbon to hydrogen. Flame cores typically result in an undesirable graphitic phase blocking char formation. The high temperature reactions developed by the ER-C act to vaporize the inclusive inert minerals and promote further chemisms to atomize any potentially present tars/chars to a gaseous state.

According to another feature of the invention, the ER-C, when utilized with catalytic additives, can convert pollutant by-products, such as sulfur compounds and nitrous oxides into inert, stable compounds. Consequently, the post combustion and stack emissions control costs born by fossil burning plants operated by coal firing may be substantially reduced.

According to yet another feature of the invention, insulation is disposed around the periphery of the refractory material.

Additional features of the invention will become apparent and a fuller understanding obtained by reading the following detailed description made in connection with the accompanying drawings.

BRIEF DESCRIPTION OF THE DRAWINGS

FIG. 1 is a section elevational view of a single cell entropic reactor combustor showing reactor, combustion, and discharge zones.

4

FIG. 2 is a section view of the FIG. 1 single cell entropic reactor combustor as seen from the plane 22 in FIG. 1 showing an array of air and fuel ducts.

FIG. 3 is a broken section elevational view of an alternative embodiment of the single cell entropic reactor combustor showing a diverging discharge nozzle.

FIG. 4 is an end elevation view of an entropic reactor combustor constructed in accordance with the present invention.

FIG. 5 is a section view of the FIG. 4 entropic reactor combustor as seen from the plane 5-5 in FIG. 4 showing first and second array ducts.

FIG. 6 is a section view of the FIG. 4 entropic reactor combustor as seen from the plane 6-6 in FIG. 4 showing an interspatial reactor chamber.

BEST MODE FOR PRACTICING THE INVENTION

FIGS. 1 through 3 illustrate the overall construction of a "single-cell" Entropic Reactor Combustor (single-cell ER-C) 10. As shown in FIG. 2, the single-cell ER-C 10 includes a reactor chamber refractory 14, combustion chamber refractory 16, and discharge chamber refractory 18 connected in series and defining, respectively, a reactor chamber zone 14a, combustion chamber zone 16a and discharge chamber zone 18a. The combustion chamber refractory 16 includes a venturi passage defined by an inner wall 22 of the combustion chamber refractory 16. As shown in FIGS. 2 and 3, the discharge chamber zone 18a may comprise a uniform cylindrical chamber or a diverging nozzle. Disposed around the periphery of each refractory chamber 14, 16, 18, is a high temperature insulation material 15, 17, 19, respectively, and a combustor support housing 20 connected to an end plate flange 23. In concentric relation to the three chambers 14, 16, 18 is a ceramic baffle insert 30 which extends through an opening 101 in the end plate flange 23 and a reactor core tube 84. An outer wall 34 of the ceramic baffle insert 30 sealingly engages the forward end of an inner wall 202 of the reactor chamber 14. The reactor core tube 84 extends substantially the length of the reactor chamber zone 14a whereby one end of the reactor core tube 84 is sealingly engaged by a recess 39 in the ceramic baffle insert 30 and the other end is supported by a ceramic tube support 26 and terminates into the combustion chamber zone 16a of the single-cell ER-C 10.

As shown in FIGS. 1 and 2 of the disclosed embodiment, the ceramic baffle insert 30 defines an array of entropic fuel burner ducts or pipes 64 and an array of air supply ducts 65 that are disposed around each fuel burner duct 64. The fuel burner ducts 64 and air supply ducts 65 extend longitudinally through the ceramic baffle insert 30 and terminate into the reactor chamber zone 14a (as shown in FIG. 1). In the disclosed embodiment, there are five equally spaced fuel burner pipes 64 disposed on a radius r, and six equally spaced air supply ducts 65 surrounding each fuel burner pipe 64.

A flanged combustion air chamber 110 is mounted to the end plate flange 23 by a plurality of fasteners or welds. The air chamber 110 allows combustion air to enter each air supply duct 65 at substantially the same volumetric flow rate

★???

US 6,216,613 B1

5

and pressure. The fuel burner pipes 64 extend rearwardly through the air chamber 110 and are connected to an external entropic fuel supply source (not shown). Conventional sealing methods can be used to seal the interface between the fuel burner ducts 64 and the air chamber 110.

In the disclosed embodiment, an entropic fuel, such as methane, and combustion air are entrained to burners and the products of combustion are routed through the reactor chamber zone 14a. Conventional fuel burners (not shown) initiate and maintain the necessary pyrolytics for the supply of heat to the reactor core tube 84. The burning of the entropic fuel in the reactor chamber zone 14a generates intense pyrolytic source heat for conduction through the wall of the reactor core tube 84.

The ceramic baffle insert 30 further defines a pulverized coal/gas supply nozzle 85 which is in fluid communication with the reactor core tube 84 and a pulverized coal/gas supply passage 86 connected to an external coal/gas flow control source (not shown). According to the invention, a gas, such as methane, and pulverized coal particles are dispensed into the reactor-core tube 84 through the pulverized coal/gas supply nozzle 85.

The reactor chamber 14 acts as a molecular reactor. The intense heat from the burning methane/air mixture in the reactor chamber zone 14a pyrolytically heats the reactor core tube 84. The heated reactor core tube 84, in turn, photolytically heats the pulverized coal/gas fuel mixture flowing through the reactor core 84. In effect, the chemisms that take place in the reactor core 84 radicalize the methane gas and pulverized coal. The coal particles and gas are irradiated with high energy photons within the reactor core tube 84, thereby substantially raising the specific heat of the coal/gas fuel mixture. The photons reach an energy equal to or higher than that of an electron, which causes electrons to be continually emitted. It is believed that this photolytic irradiation ionizes, or degradates, the coal molecule, and causes a debonding of its molecular structure. The gas has a hydrogenolysis effect on the pulverized coal. In other words, two hydrogen atoms are freed from the methane gas molecule, and carbon atoms from the pulverized coal bond to these two freed hydrogen atoms. For this reason, it is necessary that the gas have a sufficient amount of hydrogen to degradate the coal molecule. The gas selected should preferably have a high hydrogen to carbon ratio as in, for example, methane gas (CH₄). It is also believed that sublimation takes place during passage of the pulverized coal/gas fuel mixture through the reactor core tube 84; that is, the irradiative exposure causes a phase change in the pulverized coal/gas fuel mixture to a vaporous/gaseous state. The new fuel comprises a new group of combustible chemisms that is in the form of a vapor upon discharge from the reactor chamber 14.

Upon entry into the combustion chamber zone 16a, the new fuel undergoes detonative oxidation combustion. In the preferred and illustrated embodiment, the oxidizing media used to oxidize the new fuel flows perpendicular to the path of the new fuel. As shown in FIGS. 1 and 2, a plurality of combustion air supply pipes 54 extend radially inward through the combustion chamber refractory 16 and terminate into the combustion chamber zone 16a via respective air inlet openings 56 defined by the inside wall 22 of the

6

combustion chamber refractory 16. The air supply pipes 54 are in communication with a combustion air manifold 52 connected to a combustion air supply source (not shown). In the disclosed embodiment, the air supply pipes 54 are equally spaced apart to form a planetary spaced pattern 55. The air supply pipes 54 are positioned so that the flow of combustion air into the combustion chamber zone 16a is perpendicular to the flow of the pulverized coal/gas fuel mixture discharged from the reactor core tube 84. As shown in FIG. 1, an even amount of air supply pipes 54 is preferably used so that flow from one air supply pipe 54 collides with flow from its opposing air supply pipe 54. It is believed that the use of counterflow directed air supply pipes 54 facilitates turbulence in the combustion chamber zone 16a and substantially promotes uniform and instant exposure of the surface areas of coal particles to oxidative rate reactions.

The present invention provides significant advantages over conventional burner-type systems. It is believed that by hydrogenating the coal molecule before combustion, that the build-up of unburned hydrocarbons that is found in flame combustion or coal-firing systems is substantially reduced. According to the present invention, the pulverized coal is treated in such a manner that there is no substantial development of double bond carbon elements to produce a graphite. As alluded to above, it is believed that the carbon adheres to the free hydrogen and then becomes a liquid that is later vaporized. Consequently, the ER-C 10 substantially prevents reformed hydrocarbons and graphitic formation that is characteristic of a conventional burner or flame-type system.

A bench test model was constructed and tested to demonstrate the principles of the invention with the following dimensions and operating parameters. The reactor chamber zone 14a has a diameter of 10.01" (25.0 cm), length 24.0" (60.0 cm), circumference 31.42" (78.54 cm), and volume 1700"³ (26,800 cm³). The reactor core ceramic tube 84 has a diameter of 3.0" (7.5 cm), length 24.0" (60.0 cm), circumference 9.42" (23.6 cm), and volume 168.0"³ (2652 cm³). The combustor chamber zone 16a has a diameter of 8.0" (20.0 cm), length 10.0" (25.0 cm), circumference 25.1" (62.8 cm), and volume 510"³ (8000 cm³).

The ceramic baffle insert includes an array of five entropic fuel burner ducts 65, each duct having a diameter of 3/8 inches. The volumetric flow rate of methane gas through each duct 65 is 371 ft³/h (10.5 m³/h). Combustion-air is communicated to the reactor core chamber 14a via an array of five air supply ducts 65 that are disposed around each fuel burner duct 64. Each air supply duct 65 is preferably 3/8 inches in diameter. There are a total of 25 air supply ducts 65. The volumetric flow rate of the combustion air is about 3175 ft³/h (90 m³/h). The ratio of the circumferential surface area of the refractory reactor chamber zone 14a to the volume of the reactor chamber zone 14a is 1.0/2.5 (based on 4712 cm²/26800 cm³, or 754"²/1700"³).

The mass flow rate of the pulverized coal particles dispensed into the reactor core tube 84 through the pulverized coal/gas supply passage 86 and nozzle 85 is about 80 lb/h (36 kg/h, or 10 grams/s). The volumetric flow rate of the methane gas through the passage 86 and nozzle 85 is 380 ft³/h (10.8 m³/h, or 3000 cm³/s). The resulting ratio of

US 6,216,613 B1

7

methane gas to pulverized coal is 300 cm³/s gas to 1.0 gram/s pulverized coal. A preferred diameter of the pulverized coal/gas supply passage is 1.15" (3.125 cm). The circumferential surface area of the reactor core tube 84 (based on the internal diameter) is 226"² (1415 cm²). The ratio of the circumferential surface area of the reactor core tube 84 to the core volume of the reactor core tube is 226"²/168"³ (1415 cm²/2640 cm³).

The ER-C 10 includes four equally spaced radially positioned combustion air supply pipes 54 for directing air flow perpendicular to the flow of the reformulated pulverized coal/gas fuel expelled from the reactor core tube 84. Each pipe 54 has a diameter of 2.0" (5.0 cm). The combustion air flow rate through each air supply pipe 54 is about 360 m³/h (90 m³/h). The venturi defined by the wall 22 of the combustion chamber refractory 16 is approximately a 25 cm:20 cm reduction in cross-sectional area. The volumetric flow rate of the pulverized coal/gas fuel mixture expelled by the nozzle 85 enters the combustor combustion chamber zone 16a at approximately 13,000 cm³/s (46.8 m³/h).

The temperature in the reactor chamber zone 14a was approximately 3000-3200 degrees F. The temperature realized by the coal/gas fuel mixture in the combustion chamber zone 16a was approximately 2400-2600 degrees F. The temperature of the combustor chamber was about 3300-3500 degrees F. The power output realized was approximately 360,000 KCal/h (1,500,000 Btu/h).

Referring now to FIGS. 4 through 6, another preferred embodiment is illustrated showing the overall construction of a "multi-cell" Entropic Reactor-Combustor (ER-C) 310 for converting chemical energy of a fossil fuel to thermal energy for use in an industrial or utility power generation plant. As shown in FIG. 5, the multi-cell ER-C 310 includes a reactor chamber refractory 314, combustion chamber refractory 316, and discharge chamber refractory 318 connected in series and encased in a combustor support housing 320 with an end plate flange 323. The chambers 314, 316, 318 define, respectively, a reactor chamber zone 314a, combustion chamber zone 316a, and discharge chamber zone 318a. In concentric relation to the three chambers 314, 316, 318 is an alloy tube 325 extending through the reactor chamber zone 314a to the entry of the combustion chamber zone 316a which defines an inner oxidizing media or combustion-air manifold 322 for controlling flow of oxygen or air to the combustion chamber zone 316a. An outer ceramic baffle insert 330 and an inner ceramic baffle insert 331 are circumferentially positioned between the alloy tube 325 and the reactor chamber 314.

In communication with the inner air manifold 322 are a plurality of radial air supply ducts 340 extending outward to openings 341 in the alloy tube 325. As shown in FIG. 4, an outer oxidizing media or combustion-air manifold 352 also has a plurality of radial air supply ducts 354 extending inward to openings 356 in the combustion chamber 316.

The inner ceramic baffle insert 331 defines an array 360 of integrated entropic fuel burner ducts 364 disposed on a first radius R1 and the outer ceramic baffle insert 330 defines an array 370 of larger entropic fuel burner ducts 374 disposed on a larger second radius R2. Between the first and second radially disposed entropic fuel ducts 364, 374 is an array 80 of configured cells 384 disposed on an interme-

8

diated radius R. The open spaces or voids of the cells 384 form a continuous circumferential chamber, or an interspatial reactor core 385.

A generally circular baffle support flange-plate 410 is mounted to the end plate flange 323 by a plurality of bolts 402. The baffle support plate 410 is further connected to an interior baffle support plate 400 having an opening 401. The alloy tube 325 and the inner combustion-air manifold 322 extend through the opening 401 to an external air supply header (not shown).

FIG. 5 shows a section view of the ceramic entropic fuel ducts 364, 374. At their upstream end 361, 371 the ducts 364, 374 begin at the baffle support plates 400, 410 and are in communication with a plurality of entropic fuel supply nozzles 450 connected to an external fuel supply source and a combustion air ratioing device (not shown). The radially disposed ducts 364, 374 extend the length of the ceramic baffle inserts 330, 331 to outlets 362, 372, respectively, adjacent the entrance of the combustion chamber zone 316a.

FIG. 6 shows a section view of the array 380 of the reactor-core cells 384 which form the circumferentially configured reactor core chamber 385. At their upstream end 381 the cells 384 begin at the baffle support plates 400, 410 and are in communication with a plurality of pulverized coal/gas fuel mixture supply nozzles 460 which are connected to an external fuel flow control source (not shown). The interspatial reactor core 385 extends the length of the ceramic baffle inserts 330, 331 and terminates at a mix/ignition zone 382 located near the entrance of the combustion chamber zone 316a. A fossil fuel, such as pulverized coal, and a gas, such as methane, are dispensed into the interspatial reactor chamber 385 through the fuel supply nozzles 460.

In the disclosed embodiment, an entropic fuel, such as methane, and combustion air are entrained to burners and the products of combustion are routed through the first and second arrays 360, 370 of the entropic fuel ducts 364, 374. Conventional fuel burners (not shown in detail) initiate and maintain the necessary pyrolytics for the supply of heat to the multiple ducts 364, 374.

Referring to FIG. 4, the outer combustion-air manifold 352 supplies oxygen or air to a plurality of radially extending air supply ducts 354 and inward to air inlet openings 356 in the combustion chamber 316 (as shown in FIGS. 5 and 6). Combustion air is also simultaneously dispensed from the inner combustion-air manifold 322 outward to a plurality of radially extending air supply ducts 340 and air inlet openings 341 in the combustion chamber 316.

The use of a multi-cell ER-C 310 for fossil fuel provides several advantages over conventional burner-type systems. The burning process of entropic fuel in the ducts 364, 374 of the ceramic baffle inserts 330, 331 generates intense pyrolytic source heat for conduction through duct walls 368, 378 of the first and second arrays 360, 370 of the entropic fuel ducts 364, 374. The reactor chamber 385 utilizes an array 380 of unitized "cells" 384 which bound the interspatial reactor chamber 385. It is believed that the pulverized coal/gas fuel mixture, upon entry into the cells 384, undergoes a mechanical procedure to disperse and diffuse the pulverized coal/gas fuel mixture to effect a reduction to a decimated 1/1000 of original volumetric mass.

Different From Here on

US 6,216,613 B1

In the preferred embodiment, the outer air supply or oxidizing media ducts 354 are equally spaced apart by an angle alpha to form a planetary spoked pattern 355. The inner air supply or oxidizing media ducts 340, which are equal in number to the outer air supply ducts 354, are also equally spaced apart by an angle alpha on a corresponding planetary spoked pattern 344. As shown in FIG. 4, the convergently spoked pattern 355 is relatively offset from the divergently spoked pattern 344 by an angle of about 1/2 alpha.

It is believed that the use of the radially positioned inner/outer counterflow directed air supply ducts 340, 354 in offset relation facilitates turbulence near the mix/ignition zone 382 in the combustion chamber 316 and results in diffusivity to maximize the dispersive mixing and particle distribution of the reactives, air and fuel, in the combustion chamber 316. As a result, the heated pulverized coal/gas fuel mixture, or newly created fuel mixture, is uniformly and instantly exposed to the oxidative reaction. Pyrolytics effect the reaction-kinetics for reducing the size of the pulverized coal/gas mixture within the interspatial reactor chamber 385 with the further desirable aspect that the rate-reactions will increase as the molecular weight of the pulverized coal decreases.

The combustion technology of the ER-C 310 promotes a detonative-oxidation of the newly created pulverized coal/gas fuel mixture to entropically maximize the internal energy, or electrostatic potential, of the fuel molecule. The molecular structure of the pulverized coal and methane gas relative to the induced pyrolytics by the ER-C core 385 is electronically restructured. The resultant molecular reformations effect the critical chemisms for promoting positive phase changes of the coal molecule from solid to liquid to gas.

Like the single-cell ER-C 10 disclosed hereinabove, the multi-cell ER-C 310 utilizes the aspects of photolysis. The high density radiation in the interspatial reactor chamber 385 effects a radical restructuring of the reactants (for example, pulverized coal and methane) in a period of microseconds to a higher disbanding energy level, further maximizing the thermionically/plasmionically created excitation state of photons and electrons. These reactions promote molecular decomposition, degradation, radicalization, ionization and atomization of the pulverized coal.

The rapid ion-molecular rate-reactions effected by the multi-cell ER-C 310 maximize thermoflux and specific heats beyond the limit and efficiency of any present flame-syndrome burner system. Unlike the lengthy time sequences for the combustion of fuels experienced by existing deflagration devices, the ER-C 310 develops work chamber temperatures in excess of those presently attained by any industrial or utility plant, and at a lower cost. Averted by the ER-C 310 are the formation of flame cores resulting from reformed hydrocarbons having a higher ratio of carbon to hydrogen. The present invention eliminates or substantially reduces blocking char forming chemisms.

The multi-cell ER-C 310, in combination with conventional catalytic additives, can effect chemisms to plasmionically combine sulfurous and nitrous pollutants and substantially convert them into inert stable compounds conforming to EPA mandated specifications. Eliminating this high price for emission control costs would reflect a higher profit margin for industrial or utility plant operations.

FIG. 5 shows an entropic-reactor combustor 10 incorporating the principles of the present invention. The size, shape, quantity, and configurative spacing of the entropic fuel ducts 364, 374 geometrically defines the corresponding cells 384 which structurally equate to the resultant interspatial reactor chamber 385. Most preferably, the first array 360 includes twenty equally spaced ducts 364 disposed on a radius of approximately 32.0 cm (12.5 inches) to form a planetary pattern 366. The second array 370 includes twenty equally spaced ducts 374 disposed on a radius of approximately 49.3 cm (19.4 inches) to form an outer planetary pattern 377. Disposed approximately at the center point of the ducts 364, 374 initiating near the end plate flange 323 are entropic fuel nozzles 450. In the preferred embodiment the planetary patterns 366, 377 have coincident concentric centers C and about equal angular displacements beta, where beta is approximately 18 degrees.

According to the invention, the interspatial reactor chamber 385 preferably includes an array 380 of twenty equally spaced gaps or cells 384 disposed on a radius of approximately 39.6 cm (15.4 inches) to form a circumferential planetary pattern 388. The planetary pattern 388 is offset from the planetary patterns 366, 377 by an angle of about 1/2 beta, or approximately 9 degrees. Disposed approximately at the center of each of the reactor chamber cells 384 are fossil fuel nozzles 160.

In the disclosed embodiment, the heat conducted through the walls 368, 378 of the ducts 364, 374 relates to the composition and thickness. A preferred thickness of approximately 30 mm (1.25 inches) would effect an optimum degree of heat transfer for effecting the requisite amount of radiant heat, or photolysis, in the interspatial reactor chamber 385.

Referring now to FIG. 5 of the preferred embodiment, it is seen that the refractory chambers 314, 316, 318 may comprise a concentrically unitized structure. The outer ceramic baffle 330 preferably comprises a generally circular insert having an external wall 334 which engages an internal wall 502 and outlet port 512 of the reactor chamber refractory 314. An internal wall 335 of the inner ceramic baffle 331 engages an external wall 501 and outlet port 511 of the alloy tube 325. The interfaces 525 may be formed with any ceramic material and bonding mortar.

As shown in FIGS. 5 and 6, the resident time of thermal exposure to the pulverized coal/gas fuel mixture developed in the reactor chamber cells 384 relates to the length L of the ceramic baffles 330, 331 and the flow velocity of the pulverized coal/gas fuel mixture. In the preferred and illustrated embodiment, the length L is approximately 60 cm (24.0 inches). The velocity of the pulverized coal/gas fuel mixture through the interspatial reactor chamber cells 385 is approximately 1.0 meter (3.3 feet) per second.

According to the invention, oxidizing media or combustion-air is introduced in the combustion chamber zone 316a through the inner array of air supply ducts 340 from the inner combustion-air manifold 322. Combustion-air is simultaneously introduced in the combustion chamber zone 316a through the outer array of air supply ducts 354 from the outer combustion air manifold 352. The relative volumetric air flows from the outer/inner manifolds 352, 322 can be about: 1.0 cubic meter (35.3 cubic feet) per second/ 0.66 cubic meter (23.3 cubic ft) per second.

US 6,216,613 B1

11

Although the invention has been described with a certain degree of particularity it should be understood that those skilled in the art can make various changes to it without departing from the spirit or scope of the invention as hereinafter claimed.

What is claimed is:

1. A combustor method for treating and reacting pulverized coal for use in a fossil fuel burning plant, comprising:

- a) providing a refractory defining a reactor core and a combustor chamber in serial communication;
- b) heating said reactor core;
- c) introducing a non-oxidizing gas/coal mixture into said reactor core;
- d) transferring heat energy to the gas/coal mixture by photolytically heating the gas/coal mixture flowing through the reactor core such that the specific heat of the mixture is substantially raised;
- e) discharging the heated gas/coal mixture from the reactor core into the combustor chamber; and
- f) introducing an oxidizing medium into the combustor chamber to oxidize the heated gas/coal mixture discharged by the reactor core.

2. A method for treating and combusting pulverized coal for use in a fossil fuel burning plant, comprising:

- a) providing a refractory defining a reactor core tube and a combustion chamber in serial communication;
- b) heating said reactor core tube;

12

c) introducing a non-oxidizing gas/coal mixture into said reactor core tube;

d) transferring heat energy to the gas/coal mixture such that the specific heat of the mixture is substantially raised;

e) discharging the heated gas/coal mixture from the reactor core tube into the combustion chamber; and

f) introducing an oxidizing medium into the combustion chamber to oxidize the heated gas/coal mixture discharged by the reactor core tube.

3. A method for treating and combusting pulverized coal for use in a fossil fuel burning plant, comprising:

a) providing a refractory defining a reactor core tube and a combustion chamber in serial communication;

b) heating said reactor core tube;

c) introducing a methane gas/coal mixture into said reactor core tube;

d) transferring heat energy to the gas/coal mixture such that the specific heat of the mixture is substantially raised;

e) discharging the heated gas/coal mixture from the reactor core tube into the combustion chamber; and

f) introducing an oxidizing medium into the combustion chamber to oxidize the heated gas/coal mixture discharged by the reactor core tube.

* * * * *

Handwritten notes:
A star symbol with an arrow pointing to the "What is claimed is:" section.
"We don't do this" with a checkmark next to it.