

Liza M. Walsh (LW 4095)
CONNELL FOLEY LLP
85 Livingston Avenue
Roseland, New Jersey 07068
(973) 535-0500

Attorneys for Plaintiff Aircast, Inc.

**IN THE UNITED STATES DISTRICT COURT
FOR THE DISTRICT OF NEW JERSEY**

AIRCAST, INC.,)	Civil Action No. 04-394(WJM)
a Delaware corporation,)	
)	
Plaintiff,)	AMENDED COMPLAINT
)	
v.)	
)	
DJ ORTHOPEDICS, INC.,)	JURY TRIAL DEMANDED
a Delaware corporation, and)	
DJ ORTHOPEDICS, LLC,)	
a Delaware limited liability company,)	
)	
Defendants.)	
)	
DJ ORTHOPEDICS, INC., a Delaware)	
limited liability company,)	
)	
Counterclaimant,)	
)	
v.)	
)	
AIRCAST, INC.,)	
a Delaware corporation,)	
)	
Counterdefendant.)	
)	

Plaintiff, Aircast, Inc. ("AIRCAST"), for its complaint against defendants, DJ Orthopedics, Inc. and DJ Orthopedics, LLC (collectively "Defendants"), hereby alleges:

PARTIES

1. Plaintiff AIRCAST is a corporation organized and existing under the laws of Delaware with its principal place of business at 92 River Road, Summit, New Jersey 07902.

2. Defendant DJ Orthopedics, Inc. is a corporation organized and existing under the laws of Delaware with a principal place of business at 2985 Scott Street, Vista, California 92081.

2.1 Defendant/Counterclaimant DJ Orthopedics, LLC is a limited liability company organized and existing under the laws of Delaware and has a principal place of business at 2985 Scott Street, Vista, California 92081.

JURISDICTION AND VENUE

3. This is a civil action arising under the United States patent laws, 35 U.S.C. §§ 1 et seq.

4. This Court has jurisdiction of this action under 28 U.S.C. §§ 1331 and 1338.

5. Venue is proper in this District under 28 U.S.C. §§ 1391 and 1400.

BACKGROUND FACTS

6. AIRCAST manufactures, markets and sells, among other things, products for use in treating injuries to joints and muscles; these products include the CRYO/CUFF products, which provide cold and controlled compression to an injury.

7. On December 15, 1992, United States Patent No. 5,170,783 ("the '783 Patent") was duly and legally issued for the invention of a "CRYOTHERAPEUTIC PROCEEDURE." A copy of the '783 Patent is attached hereby as Exhibit A.

8. On June 28, 1994, United States Patent No. 5,324,318 ("the '318 Patent") was duly and legally issued for the invention of a "Cold Compress System." A copy of the '318 Patent is attached hereto as Exhibit B.

9. AIRCAST is the exclusive licensee of the '783 and '318 Patents, with the exclusive right to bring suit to enforce the patents.

10. According to Defendants' web site, Defendants manufacture, market and sell products used by orthopedic medical specialists in both surgical and non-surgical therapy. On information and belief, these products are sold in this District and elsewhere in the United States. Among Defendants' products is the "Arctic Flow" cold therapy system. This system is intended to provide cold and controlled compression to an injury.

11. Defendants have infringed and are infringing the '783 and '318 Patents by making, using, offering for sale, selling and/or importing into the United States the "Arctic Flow" cold therapy system that embodies the inventions covered by the '783 and '318 Patents.

12. Through its promotion of the "Arctic Flow" cold therapy system, Defendants are actively inducing and/or contributing to infringement by others of the '783 and '318 Patents.

13. Upon information and belief, Defendants have been and are aware of the '783 Patent and Defendants' infringement of the '783 Patent has been and is willful and deliberate. Defendants will continue their acts of infringement of the '783 Patent unless enjoined by this Court.

14. Upon information and belief, Defendants have been and are aware of the '318 Patent and Defendants' infringement of the '318 Patent has been and is willful and deliberate. Defendants will continue their acts of infringement of the '318 Patent unless enjoined by this Court.

15. Defendants' aforesaid acts of infringement have caused and are causing AIRCAST to suffer substantial damages and irreparable injury, and will continue to do so unless enjoined by this Court.

16. Upon information and belief, this is an exceptional case within the meaning of 35 U.S.C. § 285.

PRAYER FOR RELIEF

WHEREFORE, AIRCAST respectfully requests that the Court:

- (a) Temporarily, preliminarily and permanently enjoin Defendants, their officers, agents, servants, employees and attorneys, and all persons in active concert or participation with them, from infringing, contributing to the infringement of, and inducing infringement of the '783 and '318 Patents;
- (b) Order Defendants to account for and pay to AIRCAST damages adequate to compensate AIRCAST for Defendants' infringement of the '783 and '318 Patents;
- (c) Treble such damages due to the willful nature of Defendants' infringement;
- (d) Award AIRCAST its pre-judgment and post-judgment interest on such damages, and the costs, expenses and reasonable attorney's fees incurred by AIRCAST in this action; and
- (e) Award AIRCAST such other and further relief as this Court deems just and proper.

JURY DEMAND

AIRCAST hereby demands trial by jury for all issues in this action triable of right by jury.

Dated: May 25, 2004

Respectfully submitted,

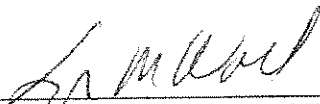

Liza M. Walsh (LW 4095)
CONNELL FOLEY LLP
85 Livingston Avenue
Roseland, New Jersey 07068
(973) 535-0500
Attorneys for Plaintiff
AIRCAST, INC.

OF COUNSEL:

Steven A. Kaufman
Crystal D. Talley
Amanda H. Moger
ROPES & GRAY LLP
One International Place
Boston, Massachusetts 02110
(617) 951-7000

RULE 201.1 CERTIFICATION

I hereby certify that the above-captioned matter is not subject to compulsory arbitration in that the monetary relief sought by plaintiff Aircast, Inc. is in excess of \$150,000 and that plaintiff Aircast, Inc. further seeks declaratory and injunctive relief.

CONNELL FOLEY LLP
Attorneys for Plaintiff
Aircast, Inc.

Dated: May 25, 2004

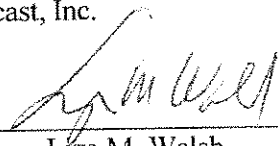
By: 
Liza M. Walsh

OF COUNSEL:

Steven A. Kaufman
Crystal D. Talley
Amanda H. Moger
ROPES & GRAY LLP
One International Place
Boston, Massachusetts 02110
(617) 951-7000

RULE 11.2 CERTIFICATION

I hereby certify that the matter in controversy is not related to any pending action or controversy.

CONNELL FOLEY LLP
Attorneys for Plaintiff
Aircast, Inc.

Dated: May 25, 2004

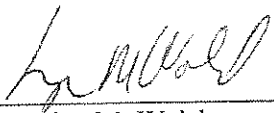
By: 
Liza M. Walsh

OF COUNSEL:

Steven A. Kaufman
Crystal D. Talley
Amanda H. Moger
ROPES & GRAY LLP
One International Place
Boston, Massachusetts 02110
(617) 951-7000

EXHIBIT A



US005170783A

United States Patent [19]
Smith

[11] **Patent Number:** 5,170,783
[45] **Date of Patent:** Dec. 15, 1992

[54] **CRYOTHERAPEUTIC PROCEDURE**
[76] **Inventor:** Kirby Smith, 3640 Blakeford Way,
NE., Marietta, Ga. 30062
[21] **Appl. No.:** 822,379
[22] **Filed:** Jan. 17, 1992

3,871,381 3/1975 Roatsonki 128/400
4,335,726 6/1982 Kolstedt 128/400
4,974,538 10/1984 Schmid-Schröber et al. 128/DIG. 3
4,739,767 4/1988 Lahr 128/656

FOREIGN PATENT DOCUMENTS

3304697 12/1983 Fed. Rep. of Germany 128/402

Primary Examiner—William H. Grieb
Assistant Examiner—Mark S. Graham
Attorney, Agent, or Firm—Caesar, Rivise, Bernstein,
Cohen & Pokotilow, Ltd.

Related U.S. Application Data

[60] Division of Ser. No. 545,295, Jan. 28, 1990, which is a continuation of Ser. No. 408,761, Sep. 18, 1989, abandoned, which is a continuation of Ser. No. 294,428, Jan. 9, 1989, abandoned, which is a division of Ser. No. 172,578, Mar. 24, 1988, abandoned.

[57] **ABSTRACT**

A cryotherapeutic procedure is disclosed for treating an injury with a cold compress system that has a flexible application bag coupled with a cold liquid supply container via a flexible tube. The flexible application bag is secured about a body member with the bag in contact with the area of injury. The supply container is elevated above the bag so that cold liquid gravitates from the supply container into the application bag causing it to fill and to apply cold and pressure to the area of injury. The height of the supply container above the application bag is adjusted to establish the desired pressure exerted by the application bag upon injury.

[51] **Int. Cl.:** A61F 7/00
[52] **U.S. Cl.:** 128/400; 128/382
[58] **Field of Search:** 128/384, 400, 402, 403,
128/DIG. 12, DIG. 3, DIG. 27, DIG. 20, 898,
379, 82.1, 656, 382; 604/4; 606/192

References Cited

[56]

U.S. PATENT DOCUMENTS

267,435 11/1882 Leiter 128/400
1,732,380 10/1929 Sarason 128/403
2,026,747 1/1936 Nemzek 128/400
2,832,336 4/1958 Davis et al. 128/402
2,930,594 3/1960 MacCracken 128/400
3,628,537 12/1971 Berndt 128/402
3,683,902 8/1972 Artemenko 128/400

6 Claims, 2 Drawing Sheets

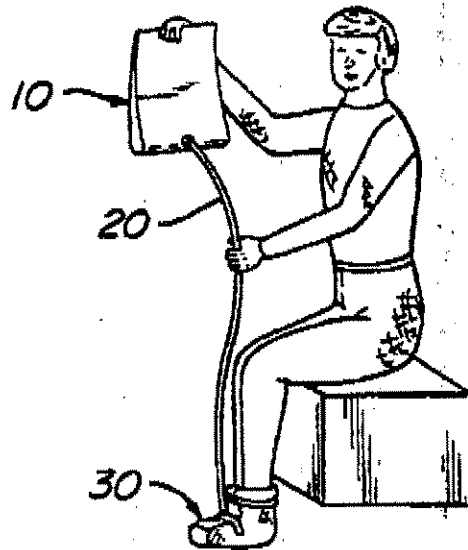

U.S. Patent

Dec. 15, 1992

Sheet 1 of 2

5,170,783

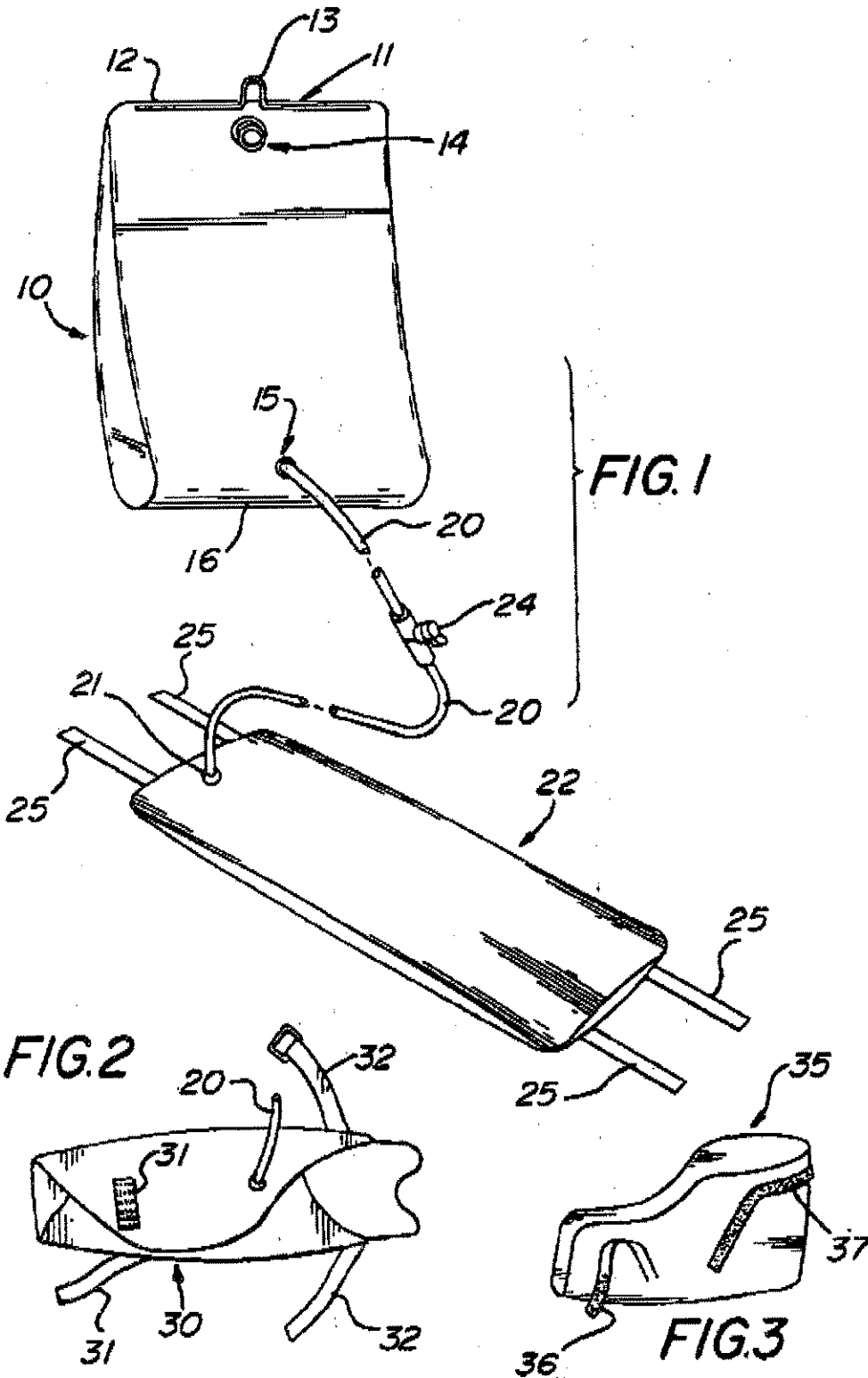

U.S. Patent

Dec. 15, 1992

Sheet 2 of 2

5,170,783

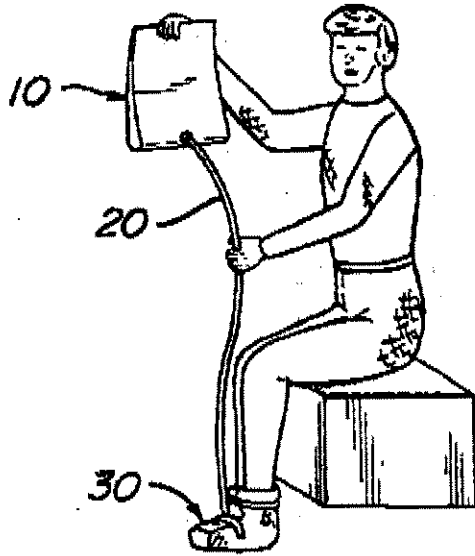

FIG. 4

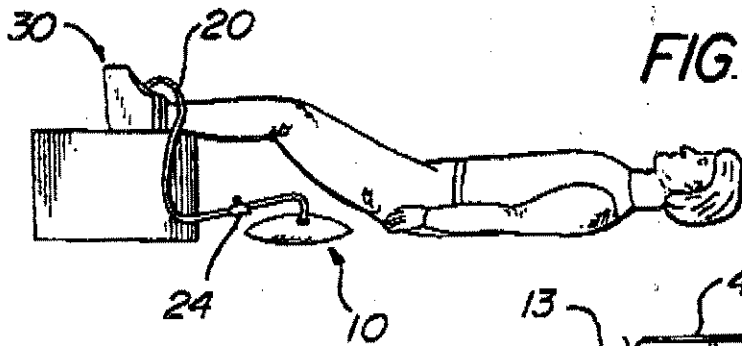

FIG. 5

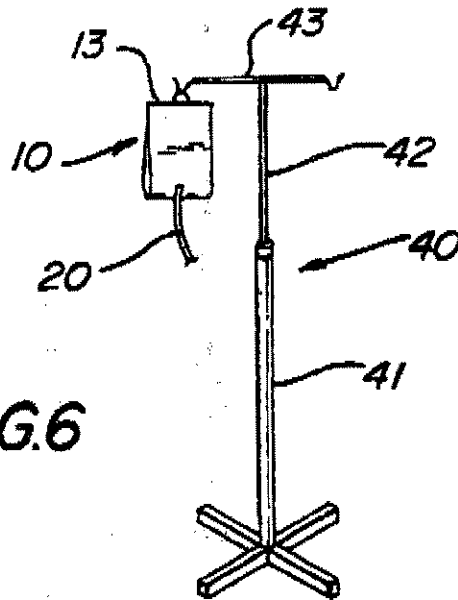

FIG. 6

1

5,170,783

2

CRYOTHERAPEUTIC PROCEDURE**PRIOR U.S. APPLICATIONS CLAIMED**

This application is a divisional application of 07/545,295, filed Jun. 28, 1990, which in turn is a continuation of 07/408,761, filed Sep. 18, 1989, now abandoned, which in turn is a continuation of 07/294,425, filed Jan. 9, 1989, now abandoned, which in turn is a division of 07/172,578, filed Mar. 24, 1988, now abandoned.

TECHNICAL FIELD

This invention relates to devices and procedures for use in applying cold and compression to body injuries such as trauma induced and postoperative edema.

BACKGROUND OF THE INVENTION

The use of cold therapy, now termed cryotherapy, is ancient. Indeed, Hippocrates is reported to have noted in 400 B.C. that the application of cold injuries tends to decrease swelling and to reduce pain by producing numbness. The topical application of pressure to injuries is also well known as a cryotherapeutic technique. Particularly in sports medicine, today cryotherapeutic procedures are commonly used to reduce edema and tissue damage.

Cryotherapy is also practiced as a postoperative procedure in hospitals with the use of electrically powered apparatuses that create compression and which circulate cold fluids. Outside of institutions such as hospitals, however, the use of electrically powered machines is often impractical or not feasible as all as where no source of electric power is available. Also, where long term treatment is needed for ambulatory patients the coupling of such equipment to the patients as they move about is cumbersome. For the foregoing reasons cold compresses of simple construction have been devised for applying cryotherapy in home and outdoor environments.

Ice packs and bandages have provided the simplest forms of cold compresses. More sophisticated compresses have included reusable cold packs designed to be wrapped around body members such as that known as The Ice Down sold by I.C.E. Down Corporation of Delmar, California. Exemplary of the more advanced compression only type products is that known as the Air-Stirrup ankle brace which permits normal flexion to reduce swelling. Other devices have utilized small bottles of pressurized refrigerants for introduction into specially designed boots or the like to provide both a chemical cold pack as well as some degree of compression. A cold compress sold under the name Compac has also been recently marketed as an alternate to ice bags. It is designed to be stored in a refrigerator for later use by being molded about an injury.

Though small cold compresses are seen now to have been developed that provide improvements over simple ice bags and the like, they have not been capable of providing substantial pressure. Compression devices have essentially remained in the domain of the larger type apparatuses that are connected to electrically powered air compressors. Thus, were a relatively small cold compress system to be devised by which both cold and compression could be applied in a substantial and yet easy manner, a distinct advance in the art would be

achieved. It is to the provision of such therefore that the present invention is primarily directed.

SUMMARY OF THE INVENTION

In one form of the invention a cold compress system comprises a flexible application pack adapted to be wrapped about an injured body member and which bears fastening means for holding the application bag in place. A cold water supply container is provided from which a flexible tube extends to the application pack to provide fluid communication therebetween. The system also includes valve means for controlling the flow of water between the application pack and supply container.

In another form of the invention, a cold compress system comprises a reservoir into which a cold liquid may be introduced, an inflatable bag, and fastening means for holding the inflatable bag in a position wrapped securely about an injured body member as the bag is inflated. The system also has means for transferring cold liquid between the reservoir and the bag while the bag remains wrapped securely about the body member. Means are also provided for controlling the transfer of cold liquid between the reservoir and the bag.

A cryotherapeutic procedure is provided for treating an injury. In accordance with the procedure an inflatable bag is wrapped about the injury and secured in place so that bag inflation and deflation, caused by infusion and expulsion of a liquid into and out of the bag, alters the pressure applied by the bag to the injury. A cold liquid is then introduced into the bag from a reservoir elevated above the bag until the bag is substantially fully inflated in its secured configuration.

In yet another form of the invention a cryotherapeutic procedure is provided for treating an injury with a cold compress system of the type that has a flexible application bag coupled with a cold liquid supply container via a flexible tube. The procedure comprises the steps of securing the flexible application bag about a body member with the bag in contact with the injury and elevating the supply container above the bag whereby cold liquid gravitates from the supply container into the application bag. This action causes the bag to fill and to apply cold and pressure to the area of injury. The height of the supply container is adjusted above the application bag to establish the desired pressure exerted by the application bag upon the injury.

BRIEF DESCRIPTION OF THE DRAWING

FIG. 1 is a perspective view of a cold compress system embodying principles of the invention which may be utilized in practicing a cryotherapeutic procedure of the invention.

FIG. 2 is a top view of an application pack in an alternative form configured into the shape of a boot.

FIG. 3 is a perspective view of an application pack or bag of another boot-shaped configuration.

FIG. 4 illustrates a person performing the inventive procedure with the cold compress system while seated.

FIG. 5 illustrates a person performing the inventive procedure with the cold compress system while lying down.

FIG. 6 is a perspective view of an I.V. stand supporting a reservoir component of the cold compress system.

DETAILED DESCRIPTION

With reference next to the drawing, there is shown in FIG. 1 a cold compress system which comprises a flexi-

3

5,170,783

ble supply container or reservoir 10 that has a top end 11 that is heat sealed about a wire 12. The wire is formed with a hook 13 for use in hanging the reservoir from an ancillary support. The container 10 is also provided with a port 14 located above its open upper end 11, and which is here shown temporarily closed by a plug, and an outlet 15 located adjacent its bottom end 16.

An elongated, flexible tube 20 extends from the outlet 15 to an inlet 21 of a flexible application pack or bag 22 of generally rectangular configuration. A hand operable flow control valve 24 is provided in the tube 20 for use in controlling the flow of liquid between the reservoir and the application pack. The pack 22 has straps 25 that bear releasably interlockable masses of fibers such as Velcro.

In preparation for use, the valve 24 is turned to its off position and ice water, with or without a supply of ice cubes, is poured into the reservoir 10 through the port 14. The flexible application pack 22 is then wrapped about an area of injury such as a body limb like a leg or an arm. With the application bag in its deflated configuration wrapped snugly about the limb, it is secured in place with the Velcro bearing straps 25 placed one upon the other in mating engagement.

Next the reservoir 10 is elevated above the now secured application bag and the valve 24 opened whereupon cold water flows down the reservoir and into the application bag. As this occurs the application bag expands and inflates until it is constrained from further significant inflation by the straps 25. As the bag inflates in its constrained state, it commences to apply pressure and cold to the injured body limb. Once the bag has reached its expansion limit imposed by the fastening of the straps 25 this pressure is adjusted by adjusting the height or elevation of the reservoir, with some cold water remaining in it, above the application bag.

A person using the cold compress system just described way, for example, sit while holding the reservoir bag 10 above himself as illustrated in FIG. 4. With valve 24 open the pressure exerted by the boot-shaped application bag or pack here, which is shown in more detail in FIG. 2, is established by the height at which the person holds the reservoir 10. In other words, if the pressure is too great he simply lowers the bag. Conversely, to increase the pressure he elevates the bag. He may continue to hold the bag at a desired elevation and pressure or he may close valve 24 so that the elevation of the reservoir then ceases to effect the pressure applied by the application bag. This enables him, for example, to lie down with his foot propped up as shown in FIG. 5 and with the reservoir laid on the ground or floor. Alternatively, the reservoir 10 may be suspended as from a stand 40 as shown in FIG. 6. In this case, the stand is a conventional I.V. stand that has a height adjustable member 42 that projects out of a tube base 41. The bag 10 is suspended from a hanger rod 43 mounted atop the member 42.

To terminate the therapy the straps 25 may be simply pulled apart and the application bag unwrapped from about the injury. This may be done without any operation of the valve or movement of the reservoir bag. Of course, the pressure may be more gradually decreased by lowering the reservoir bag with the valve 24 opened thereby causing the pressure applied by the bag to decrease. Even a reverse flow of cold water may occur from the application bag back to the reservoir. In any event it is seen that the system is essentially a closed

4

system although the top of the reservoir bag may be opened to receive ice cubes and cold water, or other cold liquid.

In FIG. 2 an application pack 30 is shown in a configuration that differs from the configuration of the pack 22 illustrated in FIG. 1. The application pack here is shaped to be wrapped about a foot and then secured in place by overlapping two mating strips of Velcro 31 and by buckling straps 32 about an ankle. Thus, the application bag is formable into the configuration of a boot with end portions overlapping one another and held together by the Velcro strips and the ankle strap. The boot-shaped application pack 30 where is the only difference in the cold compress system illustrated in FIG. 1 and is placeable in the same manner in fluid communications with a reservoir by means of the flexible tube 20.

In FIG. 3, an application pack 35 is shown of another configuration but still in the general shape of a boot. In this embodiment only an insubstantial amount of overlap may occur in wrapping the pack about a foot since the application bag is semi-rigidly shaped into an open-top boot. Velcro bearing straps 36 are provided for the toe end while Velcro bearing straps 37 are provided for adapting around the ankle portion of the person in securing the heel portion of the pack.

Cold compress systems of the type just described are capable of applying compressive forces of between 0-130 mm of Hg. Filled with ice water the bag typically applies a temperature of approximately 36°-38° F. to an area of injury. Compression has been found to be achievable as follows:

HEIGHT OF TOP BAG ABOVE BOTTOM BAG	mm Hg Pressure		
	FOOT	ANKLE	KNEE
1 Foot	22	24	26
2 Feet	48	46	48
3 Feet	68	66	66
4 Feet	90	87	88
5 Feet	114	110	110
6 Feet	134	131	130

It thus is seen that a cold compress system and cryo-therapeutic procedure is now provided that overcomes limitations of those of the prior art. It should be understood, however, that many modifications, additions, and deletions may be made to the specific embodiments illustrated without departure from the spirit and scope of the invention as set forth in the following claims.

I claim:

1. A method of therapeutically treating an injured body part, said method including the steps of:
 - locating a flexible, inelastic application pack on the injured body part to be treated;
 - employing fastening means associated with the application pack for securing the application pack in conformity with the injured body part; thereafter introducing a pressurizing cold liquid to said application pack from pressurizing liquid supply means via a conduit coupled between the application pack and the pressurizing liquid supply means; said pressurizing liquid supply means comprising a container for holding the cold liquid therein, said cold liquid being provided to said application pack by the steps of:
 - (a) supporting the container above the application pack so that said cold liquid is transported by

5,170,783

5

gravity to said application pack via said conduit;
and
(b) controlling the flow of the cold liquid through
the conduit means to said application pack;
controlling a desired amount of pressure applied to
the injured body member through the application
pack by establishing a predetermined elevation of
the container above the application pack, and
thereafter operating valve means to maintain said
desired amount of pressure irrespective of the ele-
vation of said container.

2. The method of claim 1 wherein the step of locating
the application pack on the injured body part is
achieved by wrapping the pack about said body part in
the region overlying the injury.

3. The method of claim 1 wherein the fastening means
includes cooperating locking surfaces. One of said sur-
faces being formed on a flexible strap constituting part
of the application pack, said step of securing the appli-
cation pack to said body member being achieved by
manipulating the strap into a position in which the co-
operating locking means engage each other.

6

4. The method of claim 1 wherein the application
pack is in the general shape of a boot having portions
adapted to overly the foot and ankle regions of a person,
including the step of locating the application pack on
the foot of a person and thereafter employing the fasten-
ing means for securing the application pack into conform-
ity with the foot and ankle region of the person, prior
to providing the pressurizing cold liquid to said applica-
tion pack.

5. The method of claim 1 wherein the container con-
stituting the pressurizing liquid supply means includes a
removable top, including the additional steps of remov-
ing the top of the container, introducing water and ice
into said container and thereafter closing said top.

6. The method of claim 1 wherein said valve means is
in the form of a valve communicating with the conduit
in a region between the pressurizing liquid supply
means and the application pack, including the additional
step, after a desired pressure has been established by
adjusting the elevation of the container relative to the
application pack, of closing said valve.

* * * * *

25

30

35

40

45

50

55

60

65

EXHIBIT B



US005324318A

United States Patent [19]
Smith

[11] **Patent Number:** 5,324,318
 [45] **Date of Patent:** Jun. 28, 1994

[54] **COLD COMPRESS SYSTEM**

- [75] **Inventor:** Kirby Smith, P.O. Box 70425, Marietta, Ga. 30007
 [21] **Appl. No.:** 545,295
 [22] **Filed:** Jun. 28, 1990

Related U.S. Application Data

- [60] Continuation of Ser. No. 408,761, Sep. 18, 1989, which is a continuation of Ser. No. 294,428, Jan. 9, 1989, abandoned, which is a division of Ser. No. 172,578, Mar. 24, 1988, abandoned.
 [51] **Int. Cl.** A61F 7/00
 [52] **U.S. Cl.** 607/104; 607/114; 607/111
 [58] **Field of Search** 128/384, 400, 402, 403, 128/DIG. 12, DIG. 27, DIG. 20, 898, 379, 82.1; 604/4; 606/142

References Cited

U.S. PATENT DOCUMENTS

26,663	1/1860	French	128/400
267,435	11/1882	Leiter	
500,568	7/1893	Ellis	128/400
1,732,380	10/1929	Sarason	128/400
2,026,747	1/1936	Nawczek	128/400
2,832,336	4/1958	Davis et al.	128/402
2,930,594	3/1960	MacCracken	257/306
3,628,537	12/1971	Berndt et al.	128/402
3,683,902	8/1972	Artemenko	128/400
3,717,145	2/1973	Berndt et al.	128/42.1
3,871,381	3/1975	Roslonki	128/402
3,888,259	6/1975	Miley	128/400
3,905,367	9/1975	Dapcich	128/400
4,139,009	2/1979	Gonzalez, Jr.	128/400
4,149,541	4/1979	Grammons et al.	128/400
4,335,726	6/1982	Kolstadt	128/400
4,376,437	4/1983	Sundheim et al.	128/82.1
4,474,538	10/1983	Schmid-Schomborn et al.	604/4
4,739,767	5/1987	Labr	128/400

FOREIGN PATENT DOCUMENTS

3304697	12/1983	Fed. Rep. of Germany	128/402
---------	---------	----------------------	---------

OTHER PUBLICATIONS

- Resume * of A Seminar on Cryotherapy—May 29–30, 1985 Anaheim, California (3 pages).
 Peripheral Edema: Pathophysiology, Evaluation and Management—1987 APTA (8 pages).
 ICE Down Cold Therapy Pack II. C.E. Down Corp., Del Mar, California (2 pages).
 Miscellaneous publication "Cryopac" boot (2 pages).
 ARTU by Universal, Ankle Treatment Emerges from the Ice Age, Kilde, Inc., Cedar Rapids, Iowa (1 page).
 The Air-Stirrup Ankle Brace, Protected Function, Aircast Incorporated, Summit, New Jersey (1 page).
 3A Bandage for Knee Joint, ipos USA, Niagara Falls, New York (1 page).
 With Little or No Motion, The Compression Knee Dressing (1 page).
 Genutrain Active Knee Support, Bauerfeind Therapeutic Aids (1 page).
 Cryotherapy and Ankle Sprains, Aircast Inc. (1 page).
 Reduction of Edema, Extremity Pumps, Intermittent Compression Unit (1 page).
 Products for Physical Medicine (1 page).
 Rehabilitation of the Amputee (1 page).

(List continued on next page.)

Primary Examiner—Mark S. Graham
Attorney, Agent, or Firm—Kennedy & Kennedy

[57] **ABSTRACT**

A cryotherapeutic apparatus is disclosed for treating an injury with a cold compress system that has a flexible application bag coupled with a cold liquid supply container via a flexible tube. The flexible application bag is secured about a body member with the bag in contact with the area of injury. The supply container is elevated above the bag so that cold liquid gravitates from the supply container into the application bag causing it to fill and to apply cold and pressure to the area of injury. The height of the supply container above the application bag is adjusted to establish the desired pressure exerted by the application bag upon injury.

14 Claims, 2 Drawing Sheets

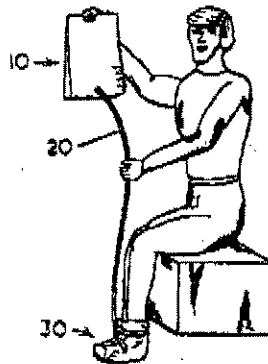

5,324,318

Page 2

OTHER PUBLICATIONS

Our Braces Are Filled with More Than Just Air. Gelcast Ankle Brace (1 page).
Compact Combination Hot & Cold Compress Therapy Pack, Compac (1 page).
Flowtron Air, Ventilated Compression System, Huntleigh Technology, Inc., Manajapan, New Jersey (2 pages).

Cold Compression Device (4 pages).
Cryotherapy in Seconds, Cryomed Corporation, Princeton, New Jersey (1 page).
Innovations The Cryopac, reprinted from May 1984 edition of Journal of Medical Services, Solana Beach, Calif. (1 page).
Resurgens, The Clinic for Reconstructive Orthopaedic Surgery, John C. Garrett, M.D., Atlanta, Ga. (1 page).

U.S. Patent

June 28, 1994

Sheet 1 of 2

5,324,318

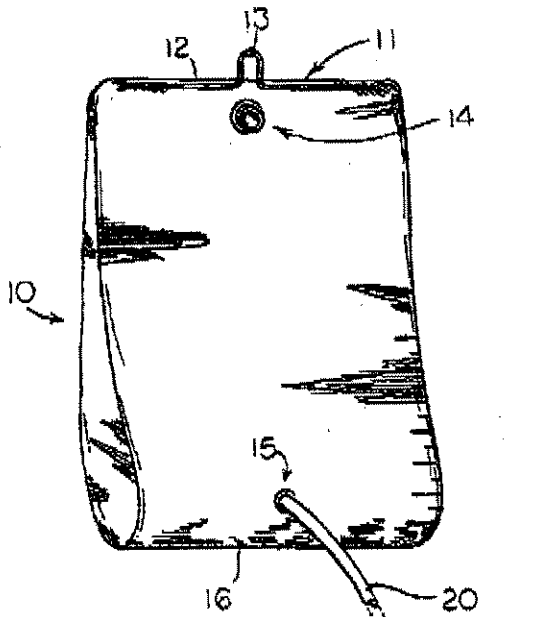

Fig 1

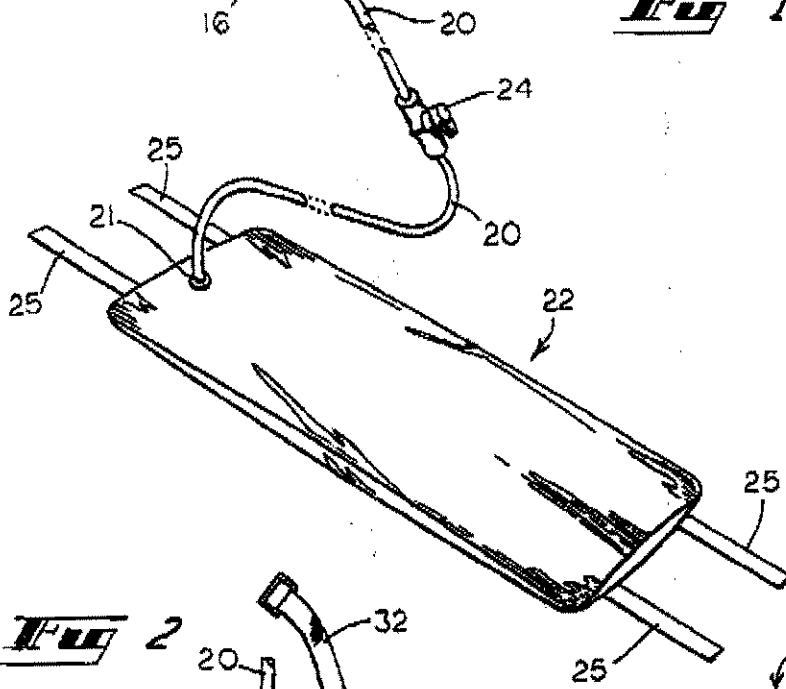

Fig 2

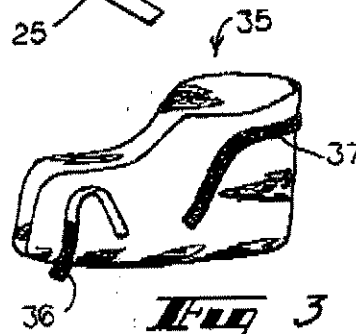
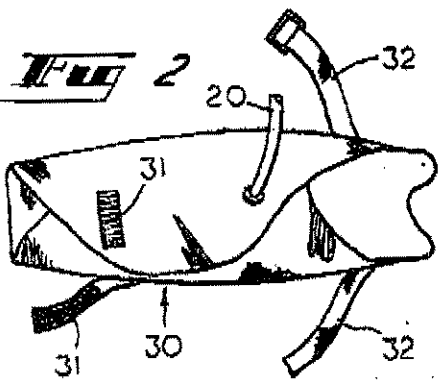

Fig 3

U.S. Patent

June 28, 1994

Sheet 2 of 2

5,324,318

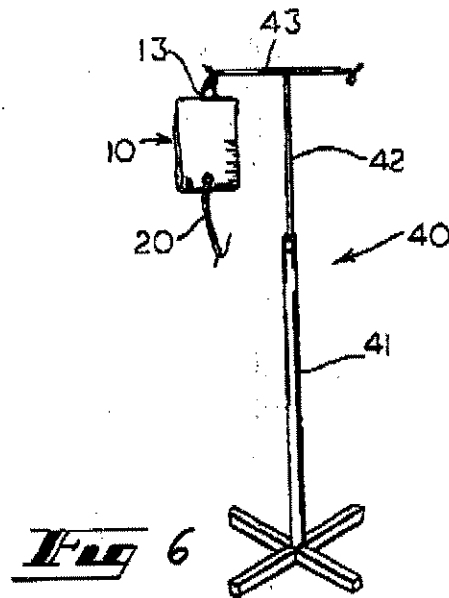
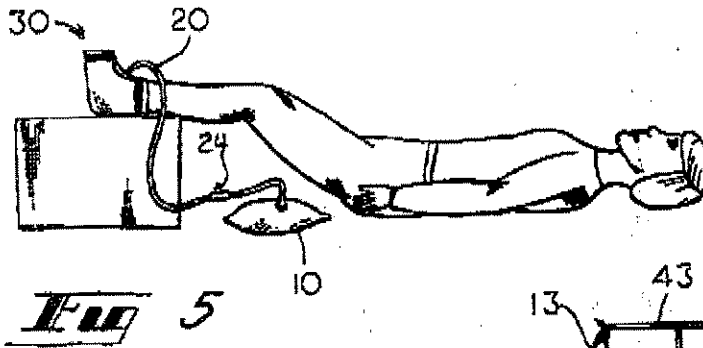
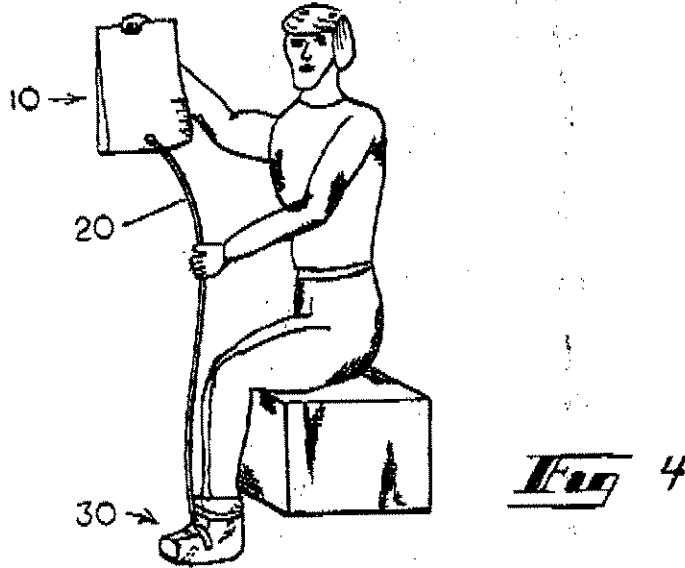

5,324,318

3

formed with a hook 13 for use in hanging the reservoir from an ancillary support. The container 10 is also provided with a port 14 located above its open upper end 11, and which is here shown temporarily closed by a plug, and an outlet 15 located adjacent its bottom end 16.

An elongated, flexible tube 20 extends from the outlet 15 to an inlet 21 of a flexible application pack or bag 22 of generally rectangular configuration. A hand operable flow control valve 24 is provided in the tube 20 for use in controlling the flow of liquid between the reservoir and the application pack. The pack 22 has straps 25 that bear releasably interlockable masses of fibers such as Velcro.

In preparation for use, the valve 24 is turned to its off position and ice water, with or without a supply of ice cubes, is poured into the reservoir 10 through the port 14. The flexible application pack 22 is then wrapped about an area of injury such as a body limb like a leg or an arm. With the application bag in its deflated configuration wrapped snugly about the limb, it is secured in place with the Velcro bearing straps 25 placed one upon the other in mating engagement.

Next the reservoir 10 is elevated above the now secured application bag and the valve 24 opened whereupon cold water flows down the reservoir and into the application bag. As this occurs the application bag expands and inflates until it is constrained from further significant inflation by the straps 25. As the bag inflates in its constrained state, it commences to apply pressure and cold to the injured body limb. Once the bag has reached its expansion limits imposed by the fastening of the straps 25 this pressure is adjusted by adjusting the height or elevation of the reservoir, with some cold water remaining in it, above the application bag.

A person using the cold compress system just described may, for example, sit while holding the reservoir bag 10 above himself as illustrated in FIG. 4. With valve 24 open the pressure exerted by the boot-shaped application bag or pack here, which is shown in more detail in FIG. 2, is established by the height at which the person holds the reservoir 10. In other words, if the pressure is too great he simply lowers the bag. Conversely, to increase the pressure he elevates the bag. He may continue to hold the bag at a desired elevation and pressure or he may close valve 24 so that the elevation of the reservoir then ceases to effect the pressure applied by the application bag. This enables him, for example, to lie down with his foot propped up as shown in FIG. 5 and with the reservoir laid on the ground or floor. Alternatively, the reservoir 10 may be suspended as from a stand 40 as shown in FIG. 6. In this case, the stand is a conventional I.V. stand that has a height adjustable member 42 that projects out of a tube base 41. The bag 10 is suspended from a hanger rod 43 mounted atop the member 42.

To terminate the therapy the straps 25 may be simply pulled apart and the application bag unwrapped from about the injury. This may be done without any operation of the valve or movement of the reservoir bag. Of course, the pressure may be more gradually decreased by lowering the reservoir bag with the valve 24 opened thereby causing the pressure applied by the bag to decrease. Even a reverse flow of cold water may occur from the application bag back to the reservoir. In any event it is seen that the system is essentially a closed system although the top of the reservoir bag may be

4

opened to receive ice cubes and cold water, or other cold liquid.

In FIG. 2 an application pack 30 is shown in a configuration that differs from the configuration of the pack 22 illustrated in FIG. 1. The application pack here is shaped to be wrapped about a foot and then secured in place by overlapping two mating strips of Velcro 31 and by buckling straps 32 about an ankle. Thus, the application bag is formable into the configuration of a boot with end portions overlapping one another and held together by the Velcro strips and the ankle strap. The boot-shaped application pack 30 here is the only difference in the cold compress system illustrated in FIG. 1 and is placeable in the same manner in fluid communication with a reservoir by means of the flexible tube 20.

In FIG. 3, an application pack 35 is shown of another configuration but still in the general shape of a boot. In this embodiment only an insubstantial amount of overlay may occur in wrapping the pack about a foot since the application bag is semi-rigidly shaped into an open-top boot. Velcro bearing straps 36 are provided for the toe end while Velcro bearing straps 37 are provided for adapting around the ankle portion of the person in securing the heel portion of the pack. Cold compress systems of the types just described are capable of applying compressive forces of between 0-130 mm of Hg. Filled with ice water the bag typically applies a temperature of approximately 36°-38° F. to an area of injury. Compression has been found to be achievable as follows:

HEIGHT OF TOP BAG ABOVE BOTTOM BAG	mm Hg Pressure		
	FOOT	ANKLE	KNEE
1 foot	22	24	26
2 feet	43	46	48
3 feet	63	66	66
4 feet	90	87	88
5 feet	114	110	110
6 feet	134	131	130

It thus is seen that a cold compress system and cryo-therapeutic procedure is now provided that overcomes limitations of those of the prior art. It should be understood, however, that many modifications, additions and deletions may be made to the specific embodiments illustrated without departure from the spirit and scope of the invention as set forth in the following claims.

I claim:

1. A cold compress system comprising a flexible inelastic application pack adapted to be wrapped about an injured body member and bearing fastening means for holding the application wrapped securely about the body member; a cold water supply container elevated above said application pack from which cold water may be gravity fed to said application pack; a flexible tube extending between said application pack and said supply container to provide fluid communication therebetween; and valve means for controlling the flow of water between said application pack and said supply container.

2. The cold compress system of claim 1 wherein said flexible application pack is of generally rectangular configuration.

3. The cold compress system of claim 1 wherein said application pack is configurable into the general shape of a boot.

5,324,318

5

4. The cold compress system of claim 1 wherein said application pack is made of plastic.

5. The cold compress system of claim 1 wherein said fastening means comprises strips of releasably interlockable fibrous materials.

6. The cold compress system of claim 1 wherein said cold water supply container is a flexible supply bag.

7. The cold compress system of claim 1 further comprising a supply of cold water in said supply container at ambient pressure.

8. A cold compress system comprising, in combination, a reservoir into which a cold liquid may be introduced and from which cold liquid may be freely drained; an inflatable inelastic bag; fastening means for holding said inflatable bag in a position wrapped securely about an injured body member as it inflates below said reservoir; means for transferring cold liquid between said reservoir and said bag while wrapped securely about the body member; and means for controlling the transfer of cold liquid between said reservoir and said bag.

6

9. The cold compress system of claim 8 wherein said inflatable bag is of generally rectangular configuration.

10. The cold compress system of claim 8 wherein said inflatable bag is configurable into the shape of a boot.

11. The cold compress system of claim 8 further comprising a supply of cold liquid in said reservoir at ambient pressure.

12. The cold compress system of claim 1 further comprising a supply of cold liquid in said supply container at ambient pressure.

13. The cold compress system of claim 1 further comprising means for supporting said cold water supply container above said application pack whereby the desired levels of pressure exerted by the application pack upon the body member may be controlled by the valve means.

14. The cold compress system of claim 8 further comprising support means for supporting said reservoir above said bag with said bag held by said fastening means in a position wrapped about the injured body member whereby control means may establish desired levels of pressure exerted by said bag upon the body member.

* * * * *

25

30

35

40

45

50

55

60

65