

E-FILING

ORIGINAL FILED

DEC 1 11 2008

Richard W. Wieking
Clerk, U.S. District Court
Northern District of California
San Jose

1 Roger D. Taylor (To Be Admitted *Pro Hac Vice*)
roger.taylor@finnegan.com
2 FINNEGAN, HENDERSON, FARABOW,
GARRETT & DUNNER, L.L.P.
3 303 Peachtree Street, N.E.
Atlanta, GA 30308-3263
4 Telephone: (404) 653-6400
Facsimile: (404) 653-6444

5 C. Larry O'Rourke (State Bar No. 219255)
6 larry.o'rourke@finnegan.com
FINNEGAN, HENDERSON, FARABOW,
7 GARRETT & DUNNER, L.L.P.
3300 Hillview Ave
8 Palo Alto, California 94304-1203
Telephone: (650) 849-6600
9 Facsimile: (650) 849-6666

10 Linda Thayer (State Bar No. 195115)
linda.thayer@finnegan.com
11 FINNEGAN, HENDERSON, FARABOW,
GARRETT & DUNNER, L.L.P.
12 55 Cambridge Parkway
Cambridge, Massachusetts 02142-1215
13 Telephone: (617) 452-1600
Facsimile: (617) 452-1666

14 Attorneys for Plaintiffs
15 MARVELL SEMICONDUCTOR, INC.
and MARVELL ASIA PTE., LTD.

C08 05544

JW
PVT

16
17 UNITED STATES DISTRICT COURT
18 NORTHERN DISTRICT OF CALIFORNIA

19 Marvell Semiconductor, Inc.
and Marvell Asia Pte., Ltd.
20 Plaintiffs,
21 v.
22 WI-LAN, INC.,
23 Defendant.

Case No. _____
COMPLAINT
JURY TRIAL DEMANDED

1 **COMPLAINT**

2 Plaintiffs Marvell Semiconductor, Inc. and Marvell Asia Pte., Ltd. (“Marvell”), for their
3 complaint against defendant Wi-LAN, Inc. (“Wi-LAN”), allege:

4 **NATURE OF THE ACTION**

5 1. This is an action for declaratory judgment of non-infringement, invalidity, and
6 unenforceability of a United States Patent pursuant to the Declaratory Judgment Act, 28 U.S.C.
7 §§ 2201-02, and the Patent Laws of the United States, 35 U.S.C. § 100 *et seq.*, and for such other
8 relief as the Court deems just and proper.

9 **INTRADISTRICT ASSIGNMENT**

10 2. This action includes patent-based declaratory judgment claims arising in connection
11 with conduct occurring in or directed to Santa Clara County. Moreover, Marvell's headquarters
12 and other facilities are located in Santa Clara County, and Marvell employees with knowledge of
13 the products likely to be at issue in this action are located within Santa Clara County.
14 Accordingly, assignment to the San Jose Division is appropriate.

15 **PARTIES**

16 3. Marvell Semiconductor, Inc. is a corporation organized under the laws of the state of
17 California. Marvell's principal place of business is 5488 Marvell Lane, Santa Clara, California
18 95054.

19 4. Marvell Asia Pte., Ltd. is a corporation organized and existing under the laws of
20 Singapore and maintains its principal place of business in Singapore.

21 5. On information and belief, defendant Wi-LAN, Inc., is a corporation organized and
22 existing under the laws of Canada and having its principal place of business at 11 Holland Avenue,
23 Suite 608, Ottawa, Ontario, Canada.

1 6. On information and belief, defendant Wi-LAN Technologies Corporation is a
2 corporation organized and existing under the laws of Canada and having its principal place of
3 business at 11 Holland Avenue, Suite 608, Ottawa, Ontario, Canada.

4 7. On information and belief, defendant Wi-LAN Technologies, Inc. is a corporation
5 organized and existing under the laws of Delaware and alleges that its principal place of business
6 is 104 E. Houston St., Ste. 300, Marshall, Texas.

7 8. On information and belief, defendant Wi-LAN V-Chip Corp. is a corporation organized
8 and existing under the laws of Canada and having its principal place of business at 41 Pullman
9 Court, Toronto, Ontario, Canada.

10 9. As alleged herein, Wi-LAN has engaged in various acts in and directed to California.

11 **JURISDICTION AND VENUE**

12 10. This Court has exclusive subject matter jurisdiction pursuant to 28 U.S.C. §§ 1331,
13 1338(a), 2201, 2202, and the Patent Laws of the United States, 35 U.S.C. §1, *et seq.* Venue is
14 proper in this judicial district pursuant to 28 U.S.C. §§1391 and 1400.

15 11. Wi-LAN purports to be the owner of rights in U.S. Patent No. 6,549,759 (“the ’759
16 Patent”). Wi-LAN has made statements and representations threatening to assert the ’759 Patent
17 against Marvell’s products with wireless capability, including, but not limited to, Marvell’s
18 products compliant with the IEEE 802.11, 802.16 and/or Bluetooth standards. Furthermore, Wi-
19 LAN has confirmed its ability and willingness to file suit.

20 12. Marvell sells, uses and/or designs products compliant with the IEEE 802.11 standard
21 and has undertaken preparations to sell, use and/or design products that comply with the Bluetooth
22 or IEEE 802.16 standards. Marvell has not infringed and does not infringe, either directly or
23

1 indirectly, any valid and enforceable claim of the '759 patent, either literally or under the doctrine
2 of equivalents, nor is it aware of any infringement of the '759 patent.

3 13. A substantial controversy exists between the parties which is of sufficient immediacy
4 and reality to warrant declaratory relief.

5 14. This Court has personal jurisdiction over Wi-LAN. Wi-LAN has conducted business in
6 and directed to California pertaining to the '759 patent, and has engaged in various acts in and
7 directed to California.

8 **THE PATENT**

9 15. The '759 patent is titled "Asymmetric Adaptive Modulation in a Wireless
10 Communication System," and bears an issuance date of April 15, 2003. A copy of the '759 patent
11 is attached hereto as Exhibit 1.

12 **COUNT I – DECLARATION OF NONINFRINGEMENT OF U.S. PATENT NO. 6,549,759**

13 16. Marvell repeats and realleges the allegations in paragraphs 1-15 as though fully set
14 forth herein.

15 17. Marvell has not infringed and does not infringe, directly or indirectly, any valid and
16 enforceable claim of the '759 patent.

17 18. As a result of the acts described in the foregoing paragraphs, there exists a substantial
18 controversy of sufficient immediacy and reality to warrant the issuance of a declaratory judgment.

19 19. A judicial declaration is necessary and appropriate so that Marvell may ascertain its
20 rights regarding the '759 patent.

21 **COUNT II – DECLARATION OF INVALIDITY OF U.S. PATENT NO. 6,549,759**

22 20. Marvell repeats and realleges the allegations in paragraphs 1-19 as though fully set
23 forth herein.

1 21. The '759 patent is invalid for failure to meet the conditions of patentability and/or
2 otherwise comply with one or more of 35 U.S.C. §§ 100 *et seq.*, 101, 102, 103, 112 and 132.

3 22. As a result of the acts described in the foregoing paragraphs, there exists a substantial
4 controversy of sufficient immediacy and reality to warrant the issuance of a declaratory judgment.

5 23. A judicial declaration is necessary and appropriate so that Marvell may ascertain its
6 rights regarding the '759 patent.

7 **COUNT III – DECLARATION OF UNENFORCEABILITY OF U.S. PATENT NO. 6,549,759**

8 24. Marvell repeats and realleges the allegations in paragraphs 1-23 as though fully set forth
9 herein.

10 25. Individuals subject to the duty of candor under 37 CFR 1.56 (“Applicants”) engaged in
11 inequitable conduct by withholding or misstating material information with intent to deceive the
12 USPTO in connection with prosecuting the '759 patent, rendering the '759 patent unenforceable.

13 26. During prosecution of the '759 patent, Applicants were aware of prior art that they
14 knew was material to patentability, including prior public disclosures material to patentability that
15 they deliberately failed to properly disclose to the USPTO with intent to deceive.

16 27. For example, on or around July 7, 2000, a document entitled "Media Access Control
17 Layer Proposal for the 802.16.1 Air Interface Specification" was submitted to the 802.16 MAC
18 Subgroup by Glen Sater, of Motorola, and Kenneth L. Stanwood, of Ensemble Corporation.
19 Kenneth L. Stanwood is a named inventor on the '759 patent.

20 28. Applicants' public disclosures, including those described above, were material to the
21 patentability of the application that issued as the '759 patent. During prosecution of the
22 application that issued as the '759 patent, with intent to deceive the USPTO, the applicants
23 intentionally failed to disclose these public disclosures to the USPTO. Under Wi-LAN's improper

1 and incorrect applications of the '759 patent's claims, these disclosures constitute prior art that
2 renders the claims of the '759 patent invalid under 35 U.S.C. §§ 102 and/or 103.

3 29. As a result of the acts described in the foregoing paragraphs, there exists a substantial
4 controversy of sufficient immediacy and reality to warrant the issuance of a declaratory judgment.

5 30. A judicial declaration is necessary and appropriate so that Marvell may ascertain its
6 rights regarding the '759 patent.

7 **PRAYER FOR RELIEF**

8 Wherefore, Plaintiffs request that judgment be entered in favor of Marvell and prays that
9 the Court grant the following relief to Marvell:

10 A. A declaration that Marvell has not infringed, either directly or indirectly, and valid
11 or enforceable claim of the '759 patent;

12 B. A declaration that the '759 patent is invalid;

13 C. A declaration that the '759 patent is unenforceable;

14 D. An order declaring that Marvell is a prevailing party and that this is an exceptional
15 case, awarding Marvell its costs, expenses, disbursements, and reasonable attorney fees under 35
16 U.S.C. § 285 and all other applicable statutes, rules and common law; and

17 E. Such other relief as this Court may deem just and proper.

18 **JURY DEMAND**

19 Plaintiffs demand a trial by jury as to all issues and claims so triable.

20 ///

21 ///

22 ///

1 Dated: December 10, 2008

Respectfully submitted,

2
3 

C. Larry O'Rourke (State Bar No. 219255)
larry.o'rourke@finnegan.com
FINNEGAN, HENDERSON, FARABOW,
GARRETT & DUNNER, L.L.P.
3300 Hillview Ave
Palo Alto, California 94304-1203
Telephone: (650) 849-6600
Facsimile: (650) 849-6666

8 Roger D. Taylor (To Be Admitted *Pro Hac Vice*)
roger.taylor@finnegan.com
9 FINNEGAN, HENDERSON, FARABOW,
GARRETT & DUNNER, L.L.P.
10 303 Peachtree Street, N.E.
Atlanta, GA 30308-3263
11 Telephone: (404) 653-6400
12 Facsimile: (404) 653-6444

13 Linda Thayer (State Bar No. 195115)
linda.thayer@finnegan.com
14 FINNEGAN, HENDERSON, FARABOW,
GARRETT & DUNNER, L.L.P.
15 55 Cambridge Parkway
Cambridge, Massachusetts 02142-1215
16 Telephone: (617) 452-1600
17 Facsimile: (617) 452-1666

18 Attorneys for Plaintiffs
MARVELL SEMICONDUCTOR, INC.
19 and MARVELL ASIA PTE., LTD.

Exhibit

1

US 6,549,759 B2

Page 2

U.S. PATENT DOCUMENTS

5,517,503 A 5/1996 Hess
 5,615,212 A 3/1997 Ruszczyk et al.
 5,638,371 A * 6/1997 Raychaudhuri et al. .. 370/310.2
 5,638,374 A 6/1997 Heath
 5,663,990 A 9/1997 Bolgiano et al.
 5,675,573 A 10/1997 Karol et al.
 5,751,708 A 5/1998 Eng et al.
 5,768,254 A 6/1998 Papadopoulos et al.
 5,828,695 A 10/1998 Webb
 5,859,619 A 1/1999 Wu et al.
 5,890,055 A 3/1999 Chu et al.
 5,909,469 A * 6/1999 Frodigh et al. 375/302
 6,006,069 A 12/1999 Langston
 6,016,311 A 1/2000 Gilbert et al.
 6,016,313 A 1/2000 Foster, Jr. et al.
 6,038,455 A 3/2000 Gardner et al.
 6,049,566 A 4/2000 Saunders et al.
 6,094,421 A 7/2000 Scott
 6,112,080 A 8/2000 Anderson et al.
 6,170,061 B1 1/2001 Beser
 6,363,241 B1 3/2002 Barakat et al.
 6,434,189 B1 * 8/2002 Murphy 375/222
 6,470,005 B1 * 8/2002 Knutson et al. 360/347

OTHER PUBLICATIONS

Ulm., et al., "Data-Over-Cable Interface Specifications, Radio Frequency Interface Specification", Hewlett Packard Interim Specification, Doc. Control No.: SP-RFII01-970321, published Mar. 21, 1997 by MCNS Holdings, L.P., Section 6, pp. 43-85.
 Wolf et al., "On the Weight Distribution of Linear Block Codes Formed From Convolutional Codes", IEEE, IEEE Transactions on Communications, vol. 44:9, Sep. 1996.
 "Asynchronous Transfer Mode (ATM) Technical Overview", 2nd Edition, Prentice-Hall, Oct. 1995, Chapter 3, pp. 21-25.
 Sampei, S. et al., Adaptive Modulation/TDMA Scheme for Personal Multit-Media Communication Systems, (Nov. 28, 1994) Telecommunications Conference (Globecom), IEEE, pp. 989-993.
 Ue, Toyoki et al., Symbol Rate and Modulation Level Controlled Adaptive Modulation/TDMA/TDD for Personal Communication Systems, (Jul. 25, 1995) Proceedings of the Vehicular Technology Conference, IEEE, vol Conf. 45 pp 306-310.

* cited by examiner

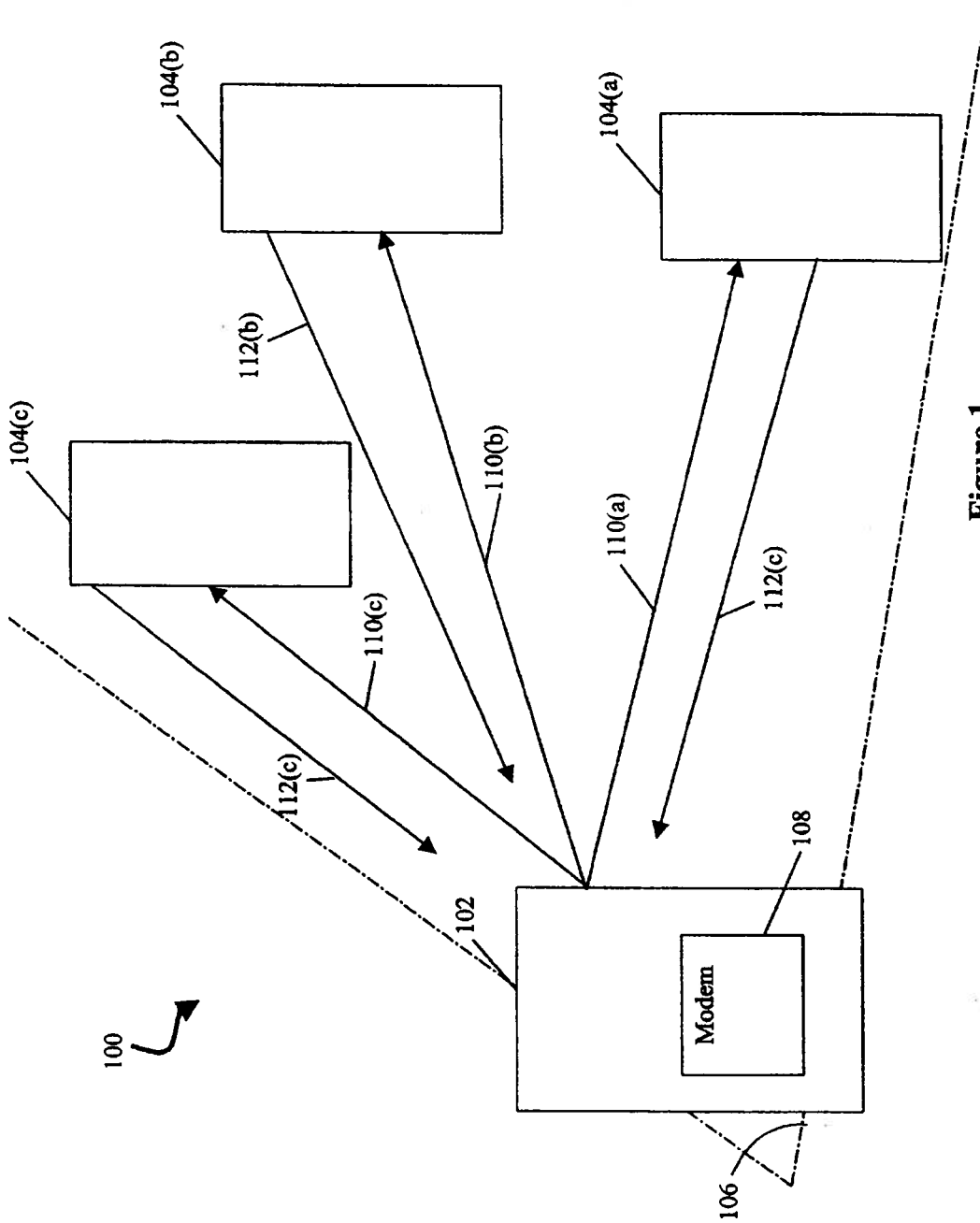

Figure 1

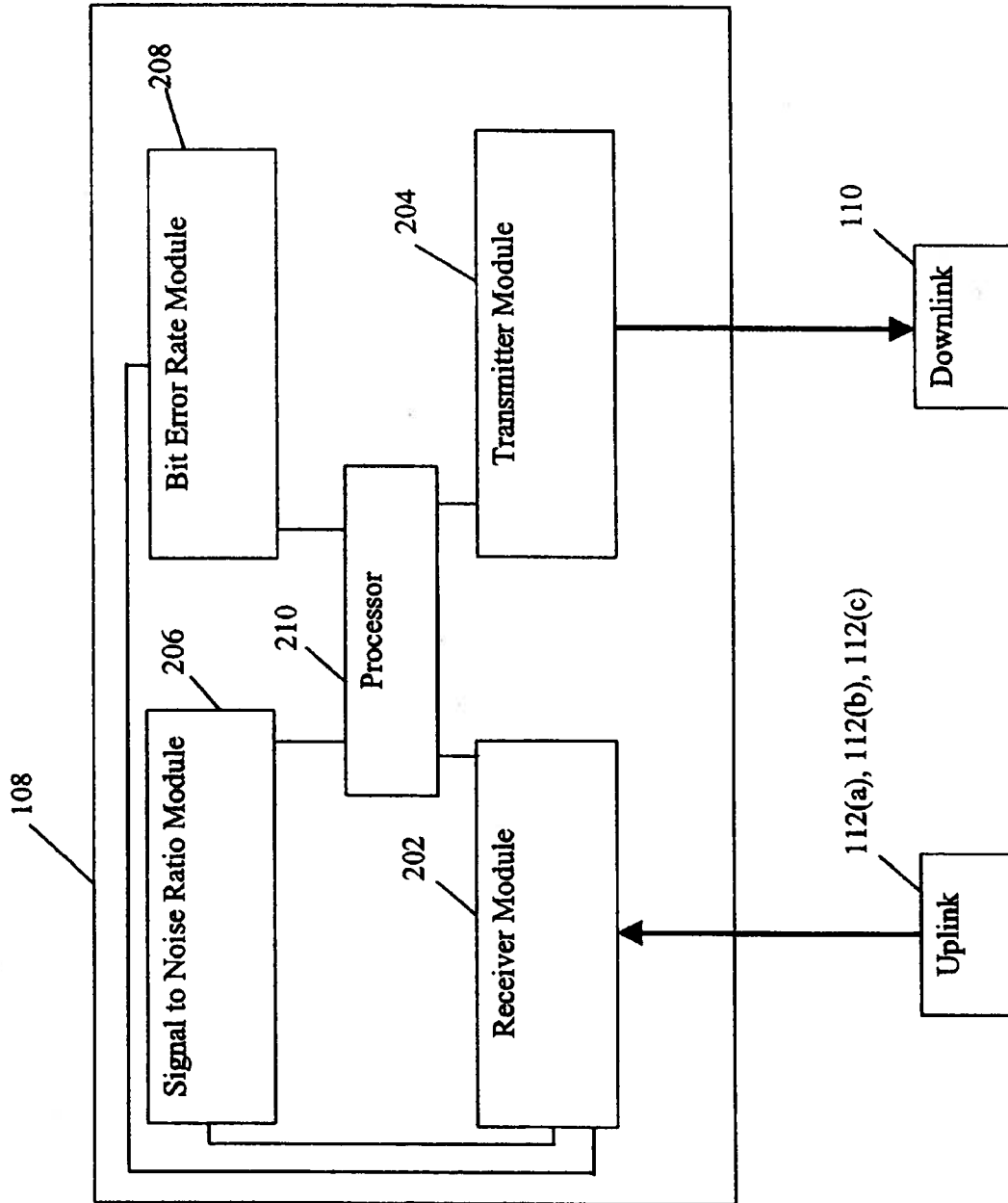

Figure 2

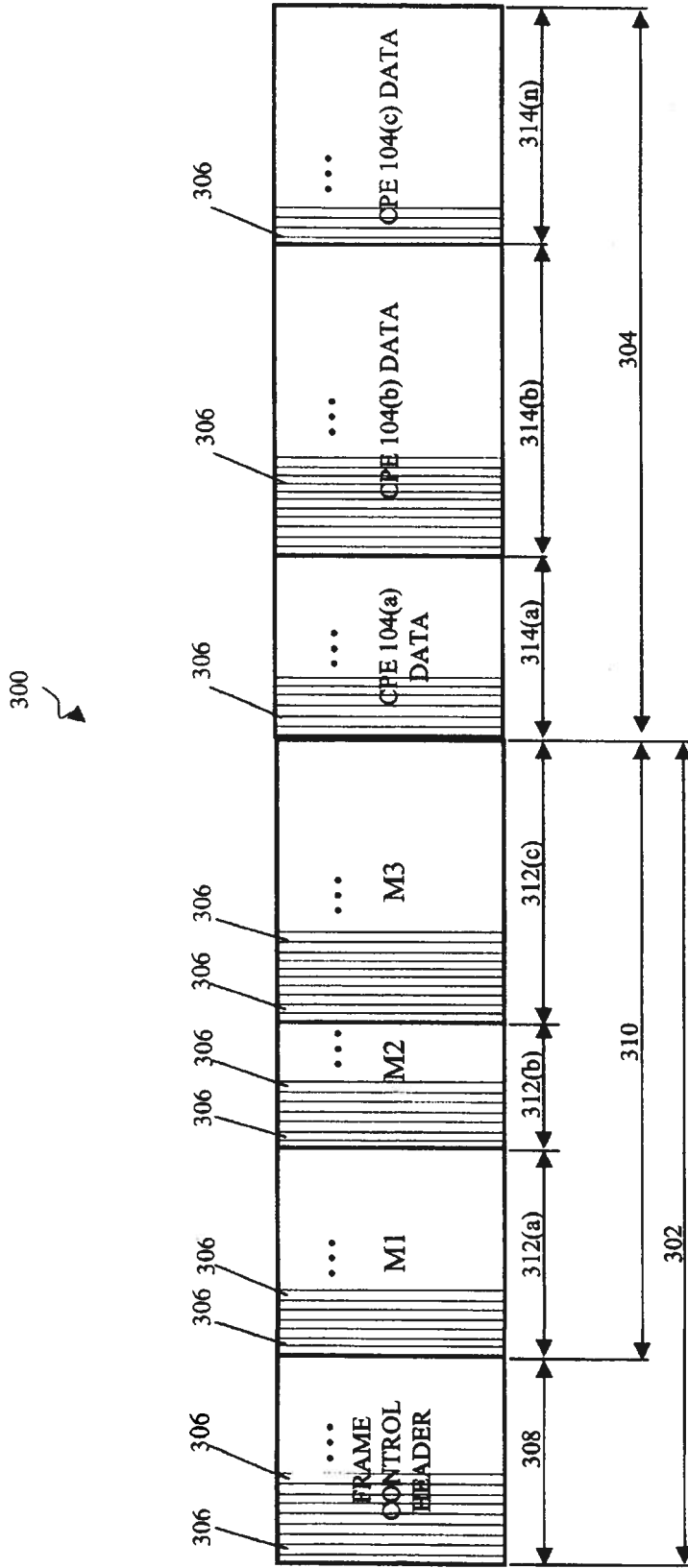

FIGURE 3

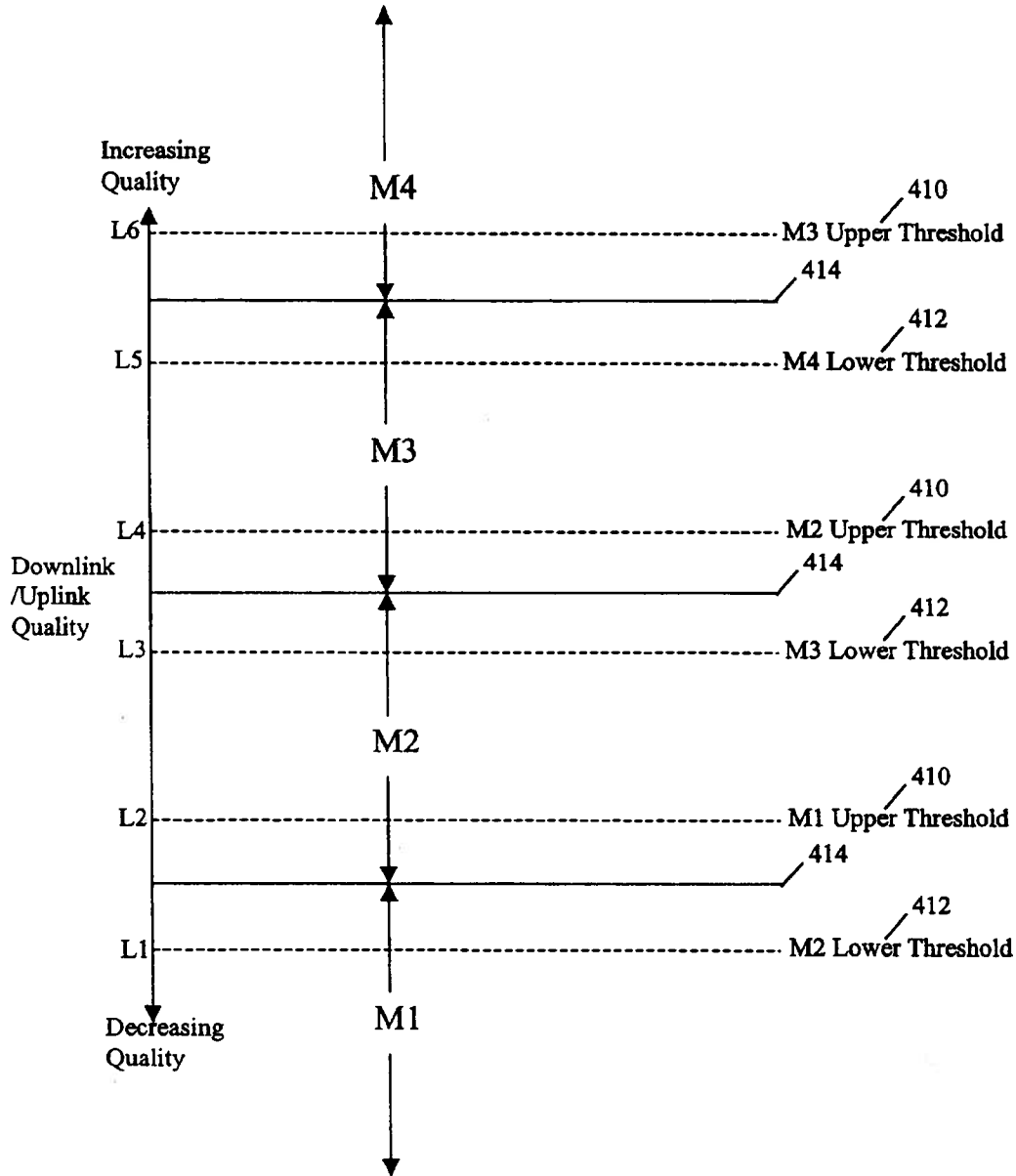

FIGURE 4

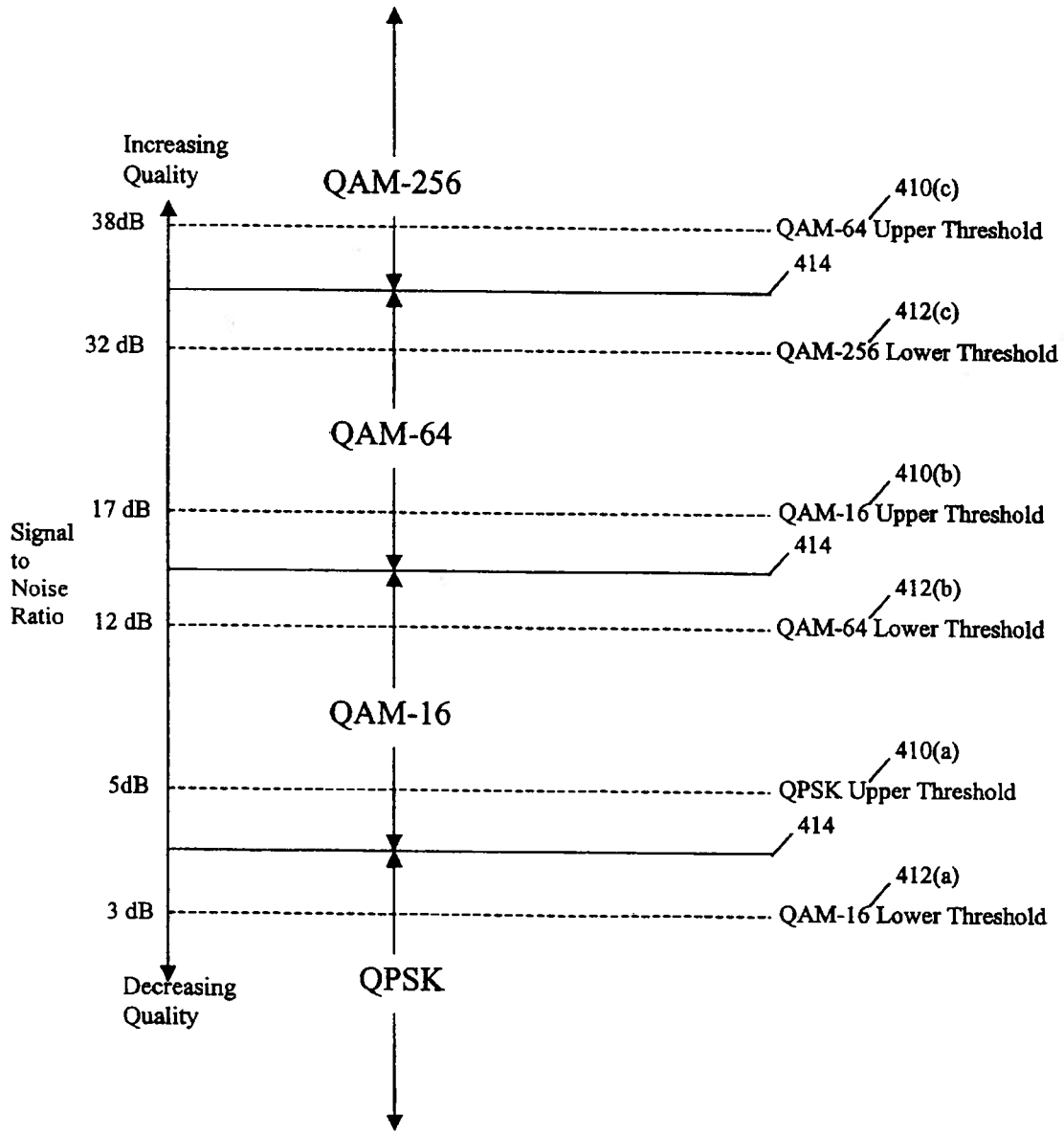

FIGURE 5

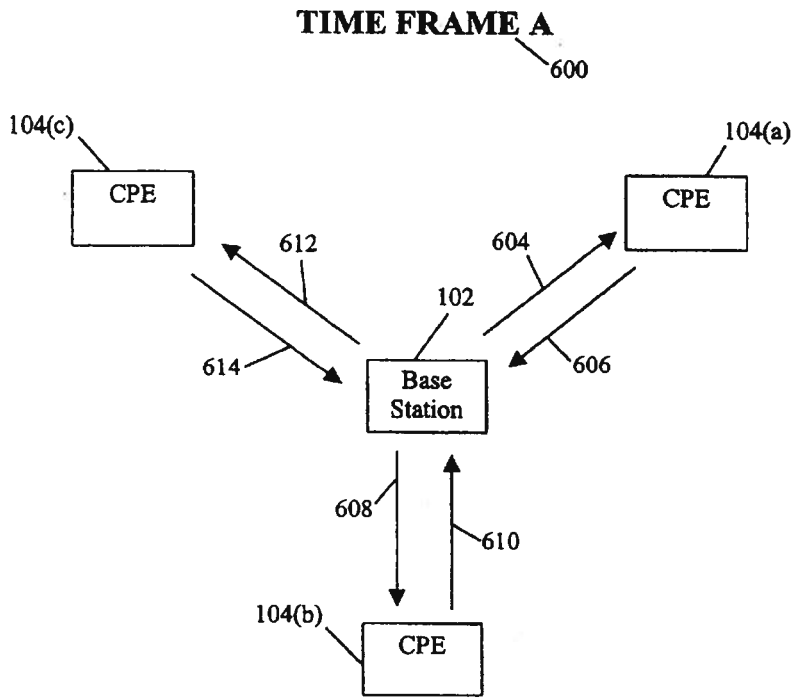

FIGURE 6A

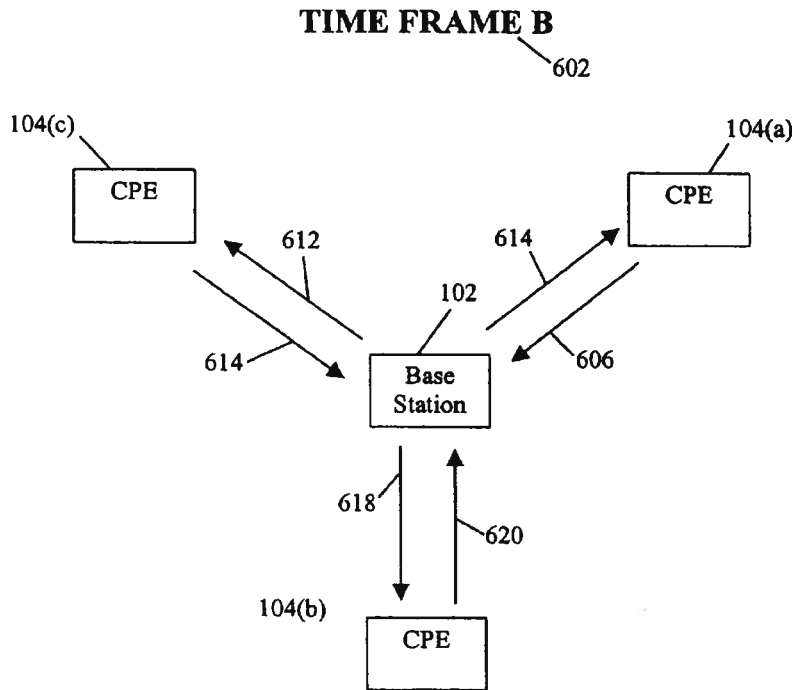

FIGURE 6B

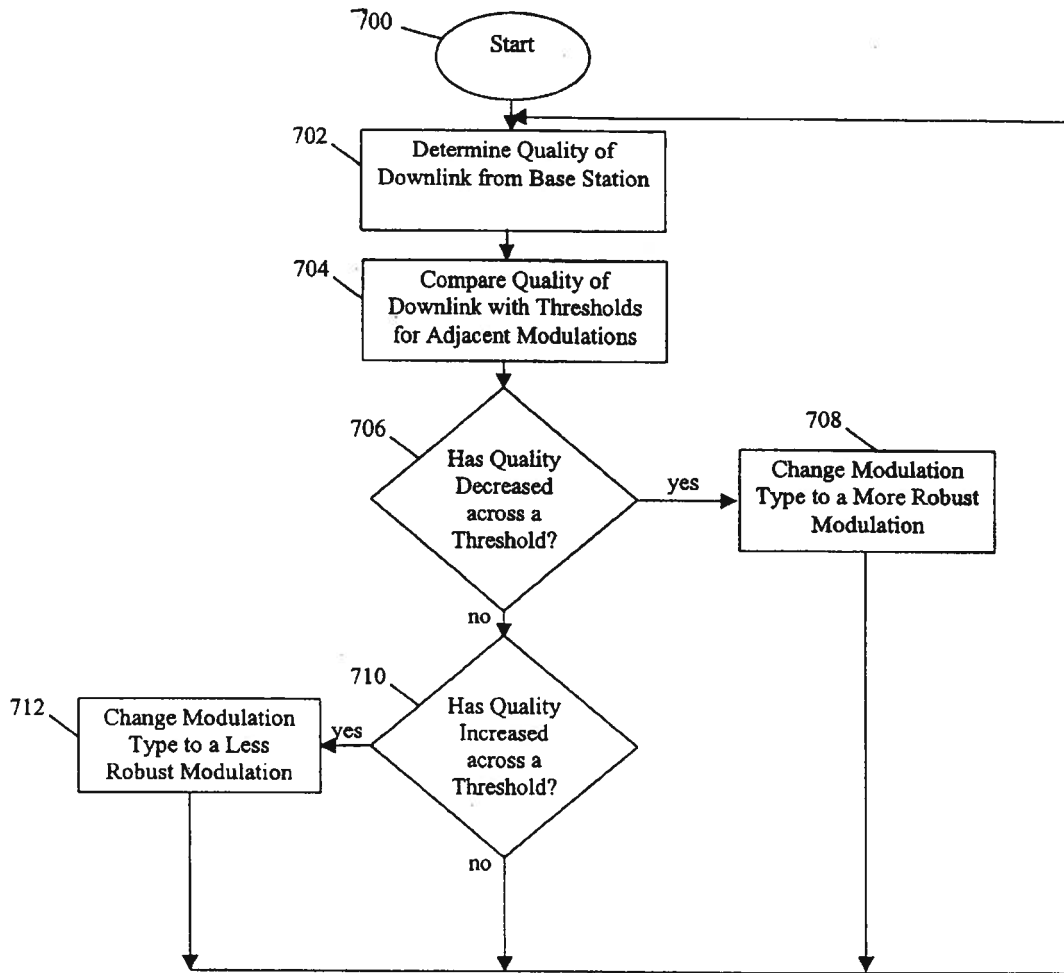

FIGURE 7

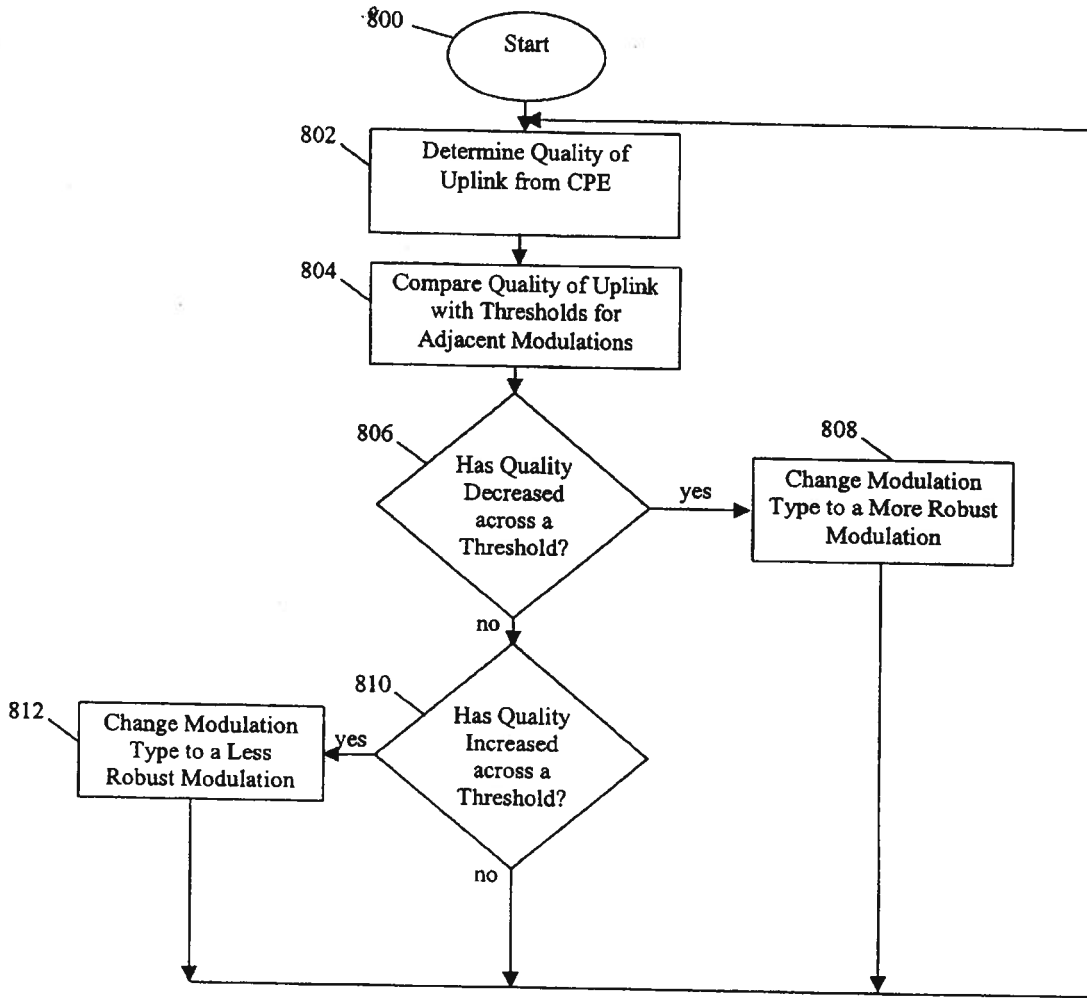

FIGURE 8

US 6,549,759 B2

1

ASYMMETRIC ADAPTIVE MODULATION IN A WIRELESS COMMUNICATION SYSTEM

BACKGROUND OF THE INVENTION

1. Field of the Invention

The present invention relates to wireless communication systems and to a system and method for implementing asymmetric modulation in such systems.

2. Description of the Related Art

A wireless communication system facilitates two-way communication between a plurality of subscriber radio stations or subscriber units (fixed and portable) and a fixed network infrastructure. Exemplary communication systems include mobile cellular telephone systems, personal communication systems ("PCS"), and cordless telephones. The key objective of these wireless communication systems is to provide communication channels on demand between the plurality of subscriber units and their respective base stations in order to connect a subscriber unit user with the fixed network infrastructure (usually a wire-line system). In the wireless systems having multiple access schemes, a time "frame" is used as the basic information transmission unit. Each frame is sub-divided into a plurality of time slots. Some time slots are allocated for control purposes and some for information transfer. Subscriber units typically communicate with their respective base station using a "duplexing" scheme thus allowing for the exchange of information in both directions of the connection.

Transmissions from the base station to the subscriber units are commonly referred to as "downlink" transmissions. Transmissions from the subscriber units to the base station are commonly referred to as "uplink" transmissions. Depending upon the design criteria of a given system, the prior art wireless communication systems have typically used either time division duplexing ("TDD") or frequency division duplexing ("FDD") methods to facilitate the exchange of information between the base station and the subscriber units.

Recently, wideband or "broadband" wireless communications networks have been proposed for delivery of enhanced broadband services such as voice, data and video. These broadband networks facilitate two-way communication between a base station and a plurality of fixed subscriber units.

Often in such broadband communication systems, multiple schemes are available for modulating and demodulating the transmitted signal. The obvious choice for the modulation scheme is the one that allows the highest transfer bit rate between the base station and subscriber units. However, limitations imposed by the communication system's design as well as variations in geographic and atmospheric conditions impede use of such high-bandwidth modulation schemes. Furthermore, these variables impact transmissions from the base station to the subscriber unit and from the subscriber unit to the base station differently. Consequently, while it is advantageous for such broadband systems to continuously utilize high-bandwidth modulation schemes, in practice, they often do not.

Thus, there is a need for a system and method which can be implemented in a broadband communication system to optimize the transmission of voice, data and video when multiple modulation schemes are available. Such a system should be flexible so as to account for variations between

2

both the uplink and the downlink in a two-way communication connection between each base station and subscriber unit pair. Moreover, a system that adaptively adjusts the modulation scheme for each individual uplink and downlink according to these variations over time would also be desirable.

SUMMARY OF THE INVENTION

One aspect is a wireless communication system for determining a plurality of uplink modulation schemes and a plurality of downlink modulation schemes for use in a wireless communication system including a base station and a plurality of customer premises equipment (CPE), where each of the plurality of uplink and downlink modulation schemes used by each of the plurality of CPE can be asymmetric, such that the uplink modulation scheme may be different than the downlink modulation scheme. The system comprises a plurality of CPE, each including a first modem configured to measure a first link quality based on received downlink data. The system further includes a base station having a second modem configured to measure a second link quality for each of the plurality of CPE based on received uplink data, a first processor configured to receive the first link quality and determine a downlink modulation scheme for each of the plurality of CPE, and a second processor configured to receive the second link quality and determine an uplink modulation scheme for each of the plurality of CPE.

Another aspect is a method for determining a plurality of uplink modulation schemes and a plurality of downlink modulation schemes for use in a wireless communication system which communicates with frames of data and includes a base station and a plurality of customer premises equipment (CPE), wherein each of the plurality of uplink and downlink modulation schemes used by each of the plurality of CPE can be asymmetric, such that the uplink modulation scheme may be different than the downlink modulation scheme. The method comprises determining an uplink quality for a first frame of data transmitted by a CPE and received by a base station, comparing the determined first uplink quality to a plurality of modulation threshold values. If the first uplink quality has crossed one of the plurality of modulation thresholds, a second uplink modulation scheme is selected for the CPE. The method further includes receiving a request for the second uplink modulation scheme at the CPE, determining a downlink quality for a second frame of data transmitted by the base station and subsequently received by the CPE, and comparing the determined first downlink quality to a second plurality of modulation threshold values. If the first downlink quality has crossed one of the plurality of modulation thresholds, a second downlink modulation scheme is selected for the CPE. The method further includes receiving a request for the second downlink modulation scheme at the base station, transmitting a third frame of data by the base station to the CPE using the second downlink modulation scheme, and transmitting a fourth frame of data by the CPE to the base station using the second uplink modulation scheme.

BRIEF DESCRIPTION OF THE DRAWINGS

FIG. 1 is a simplified block diagram of a wireless communication system.

FIG. 2 is a block diagram of a Time Division Duplex ("TDD") modem.

FIG. 3 is an illustration of the structure of a TDD frame.

FIG. 4 is a graph of multiple modulation techniques, M1-M4, and their respective upper and lower modulation thresholds.

US 6,549,759 B2

3

FIG. 5 is a graph showing modulation techniques QAM-256, QAM-64, QAM-16, and QPSK with upper and lower signal to noise ratios ("SNR") thresholds.

FIGS. 6a and 6b illustrate asymmetric adaptive modulation being performed by the base station and CPEs from FIG. 1.

FIG. 7 is a flowchart illustrating the base station performing the process of adaptively adjusting the downlink modulation scheme.

FIG. 8 is a flowchart illustrating the CPE performing the process of adaptively adjusting the uplink modulation scheme.

DETAILED DESCRIPTION OF THE PREFERRED EMBODIMENT

Embodiments of the invention will now be described with reference to the accompanying Figures, wherein like numerals refer to like elements throughout. The terminology used in the description presented herein is not intended to be interpreted in any limited or restrictive manner, simply because it is being utilized in conjunction with a detailed description of certain specific embodiments. Furthermore, embodiments may include several novel features, no single one of which is solely responsible for its desirable attributes or which is essential to practicing the embodiments herein described.

FIG. 1 is a block diagram of an exemplary wireless communication system 100. One exemplary broadband wireless communication system is described in U.S. Pat. No. 6,016,311, by Gilbert et al., issued Jan. 18, 2000, entitled "Adaptive Time Division Duplexing Method and Apparatus for Dynamic Bandwidth Allocation within a Wireless Communication System," hereby incorporated by reference. The system 100 includes a base station 102 and at least one customer premise equipment ("CPE") 104(a)-(c) receiving and transmitting data along wireless communication links 110(a)-(c), 112(a)-(c). CPE 104(a)-(c) are shown as examples which can include additional CPEs. FIG. 1 illustrates a system where three CPEs 104(a), 104(b), 104(c) are receiving and transmitting data with the base station 102 along communication link pairs 110(a) and 112(a), 110(b) and 112(b), 110(c) and 112(c).

The communication links 110(a), 110(b), 110(c) are referred to as downlinks (i.e., from the base station 102 to the CPE's 104) and can operate on a point (base station)-to-multi-point (CPE's) basis. Transmissions to and from the base station 102 are directional in nature, and thus are limited to a particular transmission sector 106 of the base station 102. Within a given sector 106, CPEs 104(a), 104(b), 104(c) receive the same transmission along their respective downlinks 110(a), 110(b), 110(c). To distinguish between data intended for a specific CPE, the CPEs monitor control information in their respective downlink 110(a), 110(b), 110(c) and typically retain only the data intended for them. In embodiments that have multiple sectors, the base station 102 includes a sectored active antenna array (not shown) which is capable of simultaneously transmitting to multiple sectors. In one embodiment of the system 100, the active antenna array transmits to four independent sectors simultaneously.

The communication links 112(a), 112(b), 112(c) are referred to as an uplink (i.e., from the CPEs 104 to the base station 102) and operate on a point-to-point basis. Thus, in FIG. 1, each CPE 104(a), 104(b), 104(c) originates its own uplink 112(a), 112(b), 112(c). Communication with the base station 102 is bidirectional and multiplexed on the basis of

4

Time Division Duplexing (TDD). For a TDD transmission from, for example, CPE 104(a), CPE 104(a) would send its data along communication link 112(c) to the base station 102 during a preassigned time slot in a transmission frame. The specific frame structures of the uplink and downlink will be discussed further below.

In a Frequency Division Duplexing (FDD) system, duplexing of transmissions between the base station and the CPEs is performed in the frequency domain. Different sets of frequencies are allocated for uplink and downlink transmissions. In one embodiment, the system described herein is used in such an FDD system.

Each CPE is further coupled to a plurality of end users that may include both residential and business customers. Consequently, the end users have different and varying usage and bandwidth requirement needs. Each CPE 104(a)-(c) may service several hundred or more end users, but at least one end user will be assigned to transmit and receive data through each CPE 104.

The data transmitted along the communication links 110, 112 is in analog form, and thus a modem 108 is used to modulate the digital data prior to transmission. FIG. 1 illustrates the modem 108 being located at the base station 102, however, a similar or identical modem 108 may be used at the other end of the downlinks 110(a), 110(b), 110(c) to demodulate the received analog data. Thus, the modems 108 in the base station and each CPE are used for uplinking data from the CPEs to the base station and for downlinking data from the base station to the CPEs.

Still referring to FIG. 1, the broadband wireless communication system 100 provides "bandwidth-on-demand" to the CPEs. The CPEs request bandwidth allocations from their respective base station 102 based upon the type and quality of service ("QoS") requested by the end users served by each CPE. Each of the end users potentially uses a different broadband service having different bandwidth and latency requirements. To this end, the type and QoS available to the end users are variable and selectable. The amount of bandwidth dedicated to a given service can be determined by the information rate and the QoS required by that service (and also taking into account bandwidth availability and other system parameters). For example, T1-type continuous data services typically require a great deal of bandwidth having well controlled delivery latency. Until terminated, these services require constant bandwidth allocation for each frame. In contrast, certain types of data services such as Internet protocol data services ("TCP/IP") are bursty, often idle (which at any one instant may require zero bandwidth), and are relatively insensitive to delay variations when active.

In one embodiment, the communication system modulates transmitted data according to the common capabilities of the CPEs 104 and the base station 102. The most robust modulation scheme is used as the modulation scheme for all data transmitted to and received from the base station 102. If such a system was applied to FIG. 1, a single modulation scheme would be selected for the communication links 110(a), 110(b), 110(c), 112(a), 112(b), 112(c). Often, the most robust modulation is the most stable, but the transmitted data is the least dense. For example, if CPEs 104(a), 104(b) are capable of receiving quadrature amplitude modulation-64 ("QAM-64") data, but CPE 104(c) is only capable of receiving quadrature phase shift keying ("QPSK") modulated data, both uplinks 112(a), 112(b), 112(c) and downlinks 110(a), 110(b), 110(c) would be transmitted using QPSK modulation. This creates an inef-

US 6,549,759 B2

5

efficient use of bandwidth whenever QPSK modulated data is transmitted to a QAM-64 capable CPE or base station.

In another embodiment, modulation schemes are selected for each CPE 104(a), 104(b), 104(c) and base station 102 pair. Transmission quality varies for each CPE as a function of the characteristics of the pathway (i.e. geographic, atmospheric . . .) between the CPE and the base station. Thus, the selected modulation schemes may be different for the CPEs depending on the capabilities and transmission quality of each CPE 104(a), 104(b), 104(c) and base station 102 pair. Continuing with the previous example, since CPEs 104(a), 104(b) are capable of receiving QAM-64 data coupled with adequate transmission quality between CPEs 104(a), 104(b) and the base station 102, all data transmitted between these CPEs and the base station will be modulated using QAM-64. In the same system CPE 104(c), which is only capable of receiving QPSK data, will only transmit and receive QPSK data. By using different or variable modulation schemes for different CPEs associated with a single base station, the communication system 100 as a whole increases its bandwidth utilization.

The transmission quality between the base station 102 and specific CPEs 104 may not only vary between each CPE and base station pair as described above, but may also vary over time. For example, in FIG. 1, the transmission quality may significantly decrease during a rain or snowstorm. When the link quality is decreased, there is an increased chance that transmitted data along communication links 110(a), 110(b), 110(c), 112(a), 112(b), 112(c) may be unrecognizable or lost to the receiving base station or CPE. To accommodate these time variations in link quality, one embodiment of the communication system 100 dynamically adjusts or "adapts" the modulation scheme for each base station 102 and CPE 104 pair. In such an adaptive system, the bandwidth utilization of the communication system 100 further increases.

An additional embodiment of the communication system 100 selects different modulation schemes for the uplink and downlink between each base station and CPE pair. Rather than selecting the same modulation scheme for the uplink and downlink associate with a CPE, the communication system selects the uplink and downlink modulations independently. Such a communication system is said to operate asymmetrically. In still another embodiment, the communication system 100 combines the features described above to provide an asymmetric and adaptive communication system 100.

In many of the embodiments described above, a determination as to the quality of the each communication link is used to select a modulation scheme. This determination can be made once for each communication link 110(a), 110(b), 110(c), 112(a), 112(b), 112(c) or can be made dynamically in an adaptive communication system. In one of these embodiments, a Signal to Noise Ratio ("SNR") of a received signal (either by the base station 102 or CPE 104) is used in determining the modulation scheme that the communication system should employ. SNR is a measure of signal strength relative to background noise. The ratio is usually measured in decibels (dB), such that if the incoming signal strength in microvolts is V_s , and the noise level, also in microvolts, is V_n , then the SNR in decibels is given by the formula

$$SNR=20\log_{10}(V_s/V_n)$$

If $V_s=V_n$, then $SNR=0$. In this situation, the analog signal borders on unreadable, because the noise level severely competes with it. In digital communications, this will likely cause a reduction in data speed because of frequent errors

6

that require the transmitting base station or CPE to re-send some lost data. Ideally, V_s is much greater than V_n , so SNR is positive. For example, suppose that $V_s=10.0$ microvolts and $V_n=1.0$ microvolt. Then

$$SNR=20\log_{10}(10)=20.0 \text{ dB}$$

which results in a very clear signal. If the signal is much weaker but still above the noise level, for example, 1.3 microvolts, then

$$SNR=20\log_{10}(1.3)=2.28 \text{ dB}$$

which may result in a reduction in data speed under these conditions.

During each frame, base station 102 receives transmissions from each of the CPEs 104(a), 104(b), 104(c) in turn. This requires the base station to synchronize with each sequential CPE "on the fly." In contrast, each CPE synchronizes with each downlink frame at the beginning of the frame. Once synchronized, the CPE maintains its connection until the specific data intended for it is received. As such, the synchronization activity required of the base station is a multiple of each individual CPE's synchronization activity. Thus, the base station may have difficulty in receiving data from multiple CPEs that use a more dense modulation scheme.

FIG. 2 is a block diagram of a Time Division Duplex ("TDD") modem 108 used to modulate/demodulate data in the wireless communication systems 100 described above. Modems 108 are used by the base station 102 and CPEs 104 to modulate and demodulate data. For ease of description, the modem 108 will now be described with reference to the base station 102. One embodiment of the modem 108 includes a receiver module 202, a transmitter module 204, a signal to noise ratio ("SNR") module 206, and a bit error rate ("BER") module 208. In another embodiment, the modem 108 further includes a processor 210. In operation, the transmitter module 204 converts digital data to an appropriately modulated analog signal communicated as a downlink 110, using for example, quadrature amplitude modulation ("QAM") or quadrature phase shift keying ("QPSK") modulation. The analog signal may also be up converted to a carrier frequency prior to transmission. The receiver module 202 demodulates an uplink 112(a), 112(b), 112(c) and converts it back to its original digital form.

The transmitter module 204 controls the data modulation scheme(s) for the modem 108. The transmitter module 204 interfaces with the SNR module 206 and the BER module 208 in selecting the modulation scheme used to transmit the data. The SNR module 206 can be a transceiver (not shown) configured to measure the signal to noise ratio of the received signal. Alternatively, the SNR module 206 can be a power detector (not shown) configured to measure the signal to noise ratio of the received signal. The SNR can be calculated from the bit error rate determined by the BER module 208.

The processor 210 is configured to monitor signal quality of the received signal. An example metric used by the processor to monitoring signal quality is a SNR. Signal quality is measured over a period of time, and, in response to changes in the signal quality, the processor 210 determines if the modulation should be changed. This helps avoid cyclic changes in the modulation scheme due to transient changes in the communication link's quality. In one embodiment, only the modem 108 at the base station 102 includes the processor 210. In this embodiment, each CPE measures its own signal quality and transmits its value

US 6,549,759 B2

7

within its uplink 112 to the base station 102. The processor 210 is then able to monitor the signal quality of the CPEs to determine if the downlink 110 modulation schemes should be changed. In one embodiment, the processor 210 in the base station 102 monitors its own signal quality to determine if the uplink 112 modulation should be changed.

The term "module," as used herein, means, but is not limited to, a software or hardware component, such as a FPGA or ASIC, which performs certain tasks. A module may advantageously be configured to reside on the addressable storage medium and configured to execute on one or more processors. Thus, a module may include, by way of example, components, such as software components, object-oriented software components, class components and task components, processes, functions, attributes, procedures, subroutines, segments of program code, drivers, firmware, microcode, circuitry, data, databases, data structures, tables, arrays, and variables. The functionality provided for in the components and modules may be combined into fewer components and modules or further separated into additional components and modules. Additionally, the components and modules may advantageously be implemented to execute on one or more computers within the communication system.

FIG. 3 represents a time division duplexing ("TDD") frame and multi-frame structure for use in communication system 100. Frame 300 includes a downlink subframe 302 and an uplink subframe 304. The downlink subframe 302 is used by the base station 102 to transmit information to the plurality of CPEs 104(a)-(c). In any given downlink subframe 302, all, some, or none of the transmitted information is intended for a specific CPE 104. The base station 102 may transmit the downlink subframe 302 prior to receiving the uplink subframe 304. The uplink subframe 304 is used by the CPEs 104(a)-(c) to transmit information to the base station 102.

Subframes 302, 304 are subdivided into a plurality of physical layer slots (PS) 306. Each PS 306 correlates with a duration of time. In the embodiment shown in FIG. 3, each subframe 302, 304 is one-half millisecond in duration and includes 400 PS for a total of 800 PS per frame 300. Alternatively, subframes having longer or shorter durations and with more or fewer PSs can be used.

Each downlink subframe 302 comprises a frame control header 308 and downlink data 310. The frame control header 308 includes information for the CPEs to synchronize with the base station 102. In one embodiment, the frame control header 308 includes control information indicating where modulation changes occur in the downlink. The frame control header 308 can also include a map of the subsequent uplink subframe 304 that is to be transmitted by the CPEs 104. This map allocates the PSs 306 in the uplink subframe 304 between the different CPEs. The frame control header 308 can further include a map of attributes of the downlink data 310. For example, attributes may include, but are not limited to, the locations of the PSs 306 in the subframe 302 that are intended for each individual CPE.

The downlink data 310 is transmitted in a pre-defined modulation or a sequence of modulation techniques M1, M2, M3. Individual or groups of PSs 306 in the downlink subframe 302 are assigned to data intended for specific CPEs 104. For example, the base station 102 could assign PSs in one, some, or all of the modulation techniques M1, M2, M3 for transmitting data to CPE 104(a). In FIG. 3, the data is divided into three modulations types, where QPSK (312(a)) is the most robust modulation (i.e. least prone to transmission errors caused by signal interference) and while QAM-64 (312(c)) is the least robust (i.e. most prone to

8

transmission errors caused by signal interference). In between these modulation schemes is QAM-32 (312(b)). In one embodiment, a sequence such as: QAM-4, followed by QAM-16, followed by QAM-64 is used. In other embodiments, additional modulation schemes, such as QAM-256, are used. Each CPE 104 monitors the downlink data 310 and retains only those messages intended for them. As mentioned above, in one embodiment, attributes in the frame control header 308 provide this information to the CPEs.

Still referring to FIG. 3, the uplink subframe 304 comprises uplink data 314(a)-(n). The uplink subframe 304 is used by the CPEs 104(a)-(c) to transmit information to the base station 102. The subframe 304 is subdivided into a plurality of PSs 306. Each CPE 104(a)-(c) transmits its information during its allocated PS 306 or range of PSs 306. In one embodiment, the PSs 306 allocated for each CPE are grouped into a contiguous block of a plurality of data blocks 314(a)-(n). In this embodiment, the CPEs use data blocks 314(a)-(n) to transmit the uplink subframe 304. The range of PSs 306 allocated to each block in the plurality of data blocks 314(a)-(n) is selected by the base station 102.

The data transmitted in each data block 314(a)-(n) is modulated by the transmitting CPE. For example, CPE 104(a) modulates data block 314(a). During its data block, the CPE transmits with a fixed modulation that is selected by the base station 102 based on the SNR and/or BER of its prior transmission(s) to the base station 102. In an alternate embodiment, a sequence of modulation techniques is used in each data block 314(a)-(n). In still another embodiment, the data blocks 314(a)-(n) are grouped by modulation scheme. As mentioned above, one embodiment of the uplink subframe 304 includes SNR and/or BER measurements transmitted by the CPEs for the base station to use in determining if the modulation of the downlink subframe 302 should be changed.

Each CPE 104 receives all downlink transmissions that are modulated using its current modulation scheme or are modulated using a more robust modulation scheme than its current modulation scheme. The frame control header 308 is typically modulated using the most robust modulation scheme to ensure that all CPEs 104(a)-(c) may receive it. Because each CPE receives the frame control header, each CPE 104 is initially synchronized with the downlink subframe 302 at the beginning of the frame 300. The downlink subframe is sorted by robustness, which allows each CPE to maintain synchronization during the subsequent portion of the downlink that could include data for that CPE. Data that is modulated using a less robust modulation scheme than a CPE's current modulation scheme is not listened to by that CPE. Thus, once synchronized, each CPE maintains its connection throughout the portion of the downlink subframe 302 that was modulated using a modulation scheme that is at least as robust as that CPE's current scheme. Since the CPEs are initially synchronized with the downlink subframe, when the data addressed to each specific CPE 104 is transmitted the respective CPEs 104 do not need additional time to synchronize.

In contrast, the base station 102 receives data from the CPEs 104 during subframe 304 which requires the base station 102 to synchronize with each individual CPE 104. Synchronization with each CPE 104 may take a variable amount of PSs 306 to achieve. Thus, the synchronize time needed for the base station 102 to synchronize with multiple CPEs 104(a)-(c) is a multiple of each individual CPE's synchronization activity during the downlink subframe 302. As such, the base station 102 may not be capable of

receiving data at the same modulations as individual CPE's 104. In some embodiments the base station 102 may be able to receive uplink data at a higher modulation than CPEs 104 can receive downlink data.

FIG. 4 illustrates a graph of four modulation schemes and their respective upper and lower modulation thresholds. Specifically, four modulation schemes (M1-M4, where M1 is the most robust and M4 is the least robust), and six modulation thresholds (L1-L6, where L1 indicates the lowest link quality and L6 indicates the highest link quality) are shown. Lines 414 separate the modulation schemes of FIG. 4 and are based on a defined relationship between link quality and modulation schemes. In one embodiment, the thresholds L1-L6 are identical for the uplink and downlink, such that modulation transition points are the same for both the uplink and the downlink. The thresholds are based on measurements of the quality of a communication link between a transmitting base station 102 or CPE 104(a)-(c) and a receiving CPE or base station. Quality measurements are made for the uplinks 112(a)(c) and downlinks 110(a)-(c) in FIG. 1. In one embodiment, the link quality is based on a SNR or BER measurement for the uplink or downlink. Alternatively, link quality is determined by measuring the carrier to noise ratio (C/N) or the carrier to noise plus interference ratio (C/(N+I)). For ease of description, the following assumes the modulation thresholds for the uplink and downlink are the same. The following description would then apply to both the uplink and downlink. However, in alternate embodiments, the modulation thresholds for the uplink and downlink are different. For example, the upper and lower thresholds for the uplink 112 may be shifted by a fixed amount from the corresponding upper and lower thresholds for the downlink 110.

Still referring to FIG. 4, modulation schemes M2 and M3 each have a pair of modulation thresholds associated thereto. Modulation schemes M1 and M4 each have a single threshold associated thereto since they are the minimum and maximum modulation schemes available in the embodiment of FIG. 4. The modulation thresholds include upper thresholds 410 and lower thresholds 412. In one embodiment, as the downlink/uplink quality exceeds the upper threshold 410, the modulation scheme is increased. This is accomplished by selecting a denser and less robust modulation scheme. Conversely, as the lower threshold 412 is crossed, the modulation scheme is decreased. For example, thresholds L1 and L4 are the thresholds for modulation scheme M2. If the downlink/uplink quality using M2 falls below L1, the receiving base station/CPE will initiate changing the modulation technique to M1. Alternatively, if the downlink/uplink quality using M2 rises above L4, the receiving base station/CPE will initiate changing the modulation technique to a higher type, for example, M3. Continuing with this example, if the modulation is changed to M3 because the downlink/uplink quality exceeded L4 and then the downlink/uplink quality decreases below L4, M3 will continue to be used until L3 (the M3 lower threshold) is crossed. In other words, in order for a modulation scheme to decrease, the link quality must decrease not just to line 414, but to the lower threshold 410 immediately below line 414. Likewise, in order for a modulation scheme to increase, the link quality must not only exceed line 414, but also must exceed the upper threshold 410 immediately above line 414. By spacing the upper and lower thresholds in this manner, the likelihood of rapid changes occurring between modulation schemes is decreased.

FIG. 5 is one embodiment where modulation techniques QAM-256, QAM-64, QAM-16, and QPSK are selected

along with their respective upper and lower modulation thresholds for measurements of signal to noise ratios ("SNR"). The modulation thresholds for QAM-64 transmissions are QAM-64 upper threshold 410(c) and QAM-64 lower threshold 412(b). For example, if a base station 102 is currently downlinking data to a specific CPE 104(a) using QAM-64 modulation, the modulation scheme will change when the downlink 110(a) quality goes above upper threshold 410(c), for example, at 38 dB. Likewise, when the downlink 110(a) quality goes below lower threshold 412(b), for example, at 12 dB. Furthermore, the modulation scheme will not be changed when link quality crosses either QAM-256 lower threshold 412(c) or QAM-16 upper threshold 410(b) because they are not current modulation thresholds for QAM-64. This limits rapid changes between adjacent modulation schemes caused by small fluctuations in downlink quality around an upper or lower threshold.

FIGS. 6a and 6b illustrate asymmetric adaptive modulation being performed by the base station and CPEs from FIG. 1 during two different time frames, time frame A 600 and time frame B 602. FIGS. 6a and 6b illustrate how the uplink and downlink modulations used by a base station 102 and the specific CPEs 104 are asymmetrically adaptive. In one embodiment, time frame B 602 directly follows time frame A 600. In another embodiment, time frame B 602 occurs at a later time than time frame A 600.

In time frame A 600, as shown in FIG. 6A, CPE 104(a) receives downlink 110(a) (see FIG. 1) modulated at QAM-16 604 from base station 102. CPE 104(a) transmits uplink 112(c) (see FIG. 1) modulated at QPSK 606. The qualities for the uplink 112(c) and downlink 110(a) may be different due to several factors. For example, performing multiple synchronizations by the base station 102 may affect these qualities. Additionally, because multiple CPE's 104(a)-(c) typically transmit to base station 102 during a frame 300 (see FIG. 3), the base station may receive interference between the signals from the multiple CPEs. Additionally, there may be other interference sources that only effect data transmission in only one direction. For example, co-channel and adjacent channel interference from neighboring cells or sectors can cause the link quality for an uplink to be different than the link quality for the downlink. In subsequent time frame B 602, the downlink 110(a) modulation scheme from the base station 102 is increased to QAM-64 614 while the uplink 112(c) modulation scheme from CPE 104(a) remains at QPSK 606. This occurs because the quality of the downlink 110(a) has increased beyond an upper threshold 410(b) (see FIG. 5) between time frame A 600 and time frame B 602. The quality of the uplink 112(c) has not crossed the QPSK upper threshold 410(a) (see FIG. 5), and thus the uplink 112(c) continued using QPSK 606.

Returning to time frame A 600, CPE 104(b) receives downlink 110(b) (see FIG. 1) modulated at QAM-64 608 and transmits an uplink 112(b) (see FIG. 1) modulated at QAM-16 610. Between time frame A 600 and time frame B 602, the quality for both the uplink and downlink crossed over a lower threshold 412(b), 412(a) as evidenced by the more robust modulation schemes in time frame B 602. In time frame B, the downlink 110(b) is in QAM-16 618 while uplink is in QPSK 620. Since the modulation schemes of both links have decreased, this may have occurred due to changes in weather conditions between the base station 102 and CPE 104(b).

Returning once again to time frame A 600, CPE 104(c) receives downlink 110(c) (see FIG. 1) modulated at QAM-16 612 and transmits uplink 112(c) (see FIG. 1) modulated at QAM-16 614 to the base station 102. In time frame B 602,

US 6,549,759 B2

11

both the uplink and downlink are still using QAM-16 612, 614 modulations. The link qualities of both the uplink 112(c) and downlink 110(c) between base station 102 and CPE 104(c) have not crossed either an upper threshold 410(b) or a lower threshold 412(a).

FIG. 7 is a flowchart illustrating a process for adaptively adjusting the downlink modulation scheme. The base station can adjust its downlink modulation for a specific CPE 104 independent of that CPE's uplink modulation. In one embodiment, the process is performed during each frame 300 (one millisecond, for example), or periodically over several frames (every 10 seconds, for example). The base station 102 performs the process for each CPE 104(a)-(c) within a sector 106 (see FIG. 1). In another embodiment, each CPE determines the quality of the downlink. Once determined, the CPE can report the quality information back to the base station or determine itself whether the downlink modulation should be adjusted. If the CPE determines that the downlink modulation should be adjusted based on its quality measurements, the CPE sends a request to the base station to use a different modulation technique. The base station is then able to adjust its downlink modulation accordingly for the specific CPE.

In particular, flow begins in start block 700. Flow proceeds to block 702, where the quality of the downlink 110 from the base station 102 is determined. The quality of the downlink may be a function of the state of the transmission medium (e.g. air, foggy air, wet air, smoky air, etc.) and the ability of both the transmitting and receiving components (e.g. base station 102 and CPE 104) to respectively transmit and receive data. In one embodiment, each CPE 104(a)-(c) determines the quality of its respective downlink 110(a)-(c). In another embodiment, the quality of the downlink 110 is determined by only one CPE 104. In this embodiment, the selected CPE 104 can be geographically located near the other CPEs 104 that receive the downlink 110 using the same modulation scheme. In still another embodiment, the CPEs 104 periodically transmit measurements, which are indicative of the quality of their respective downlink 110, to the base station 102. The base station 102 then uses these measurements to determine the quality of its downlink. These measurements can include SNR and/or BER measurements of the downlink 110(a)-(c). For example, CPE 104(a) determines the quality of its downlink 110(a) based on a measurement by its BER module 208 (see FIG. 2). A single BER measurement or a series of several BER measurements taken by the CPE during a frame 300 (see FIG. 3) or during multiple frames may be used to determine the downlink quality. In embodiments where the CPE include a processor 210 (see FIG. 2), multiple measurements are analyzed by the processor 210 to determine the downlink's quality. For example, BER measurements may be averaged over N frames 300 to generate the downlink quality measurement. In one embodiment, CPE 104(a) transmits its measurements to the base station 102 for analysis by a processor 210 in the base station. The base station then determines the quality of the downlink for CPE 104(a).

Continuing to block 704, the base station or CPE compares the calculated downlink quality with the current modulation thresholds, as shown in FIGS. 4 and 5. The current modulation thresholds are an upper threshold 410 and a lower threshold 412 at which the modulation scheme is changed. With reference to FIG. 5, the current modulation thresholds for a QAM-64 transmission are QAM-64 upper threshold 410(c) and QAM-64 lower threshold 412(b). For example, if the base station 102 is currently downlinking data to CPE 104(b) using QAM-64 modulation, the modulation scheme will change when the uplink quality exceeds the upper threshold 410(c) at 38 dB or goes below lower threshold 412(b) at 12 dB. Furthermore, the modulation scheme will not be changed when link quality crosses either QAM-256 lower threshold 412(c) or QAM-16 upper threshold 410(b) because they are not current modulation thresholds.

12

Next at decision block 706, the base station determines whether the downlink quality has decreased and crossed a modulation lower threshold 412 (see FIG. 4) according to the comparisons made in block 704. With reference to FIG. 5, when the modulation is QAM-256 the current modulation lower threshold 412(c) is 32 dB. For QAM-64, the current modulation lower threshold 412(b) is 12 dB. For QAM-16, the current modulation lower threshold 412(a) is 3 dB. If the current modulation lower threshold has been crossed, flow proceeds to block 708 where the base station selects a more robust modulation. In embodiments where the CPE determines the downlink quality and compares it to the modulation threshold, the CPE 104 can send a request to the base station 102 indicating a desired downlink modulation change. This request is sent during the uplink subframe. Once received by the base station 102, a downlink modulation change confirmation is transmitted to the CPE 104 indicating in which frame 300 the change will occur. In another embodiment, a confirmation message is not transmitted to the CPE 104, but instead the CPE 104 listens for its data at both the current modulation and the requested, more robust, modulation. Because the CPEs 104 receive all data transmitted by the base station 102, a change in modulation will be evident to a specific CPE 104 when data is received in the requested modulation scheme. Flow then returns to block 702.

Returning to decision block 706, if a current modulation lower threshold has not been crossed, flow proceeds to decision block 710 where the base station determines whether the downlink quality has crossed an upper modulation threshold 410. With reference to FIG. 5, when the current modulation is QAM-64 the current modulation upper threshold 410(c) is 38 dB. For QAM-16, the current modulation upper threshold 410(b) is 17 dB. For QPSK, the current modulation upper threshold 410(a) is 5 dB. If the base station determines that the current modulation upper threshold has been exceeded, flow continues to block 712 where the modulation scheme is changed to a less robust, denser modulation. In embodiments where the CPE determines the downlink quality and compares it to the modulation threshold, the CPE 104 sends a request to the base station 102 indicating a desired downlink modulation change. Once received by the base station 102, a downlink modulation change confirmation is transmitted to the CPE 104 indicating in which frame 300 the change will occur. In another embodiment, a confirmation message is not transmitted to the CPE 104, but instead the CPE 104 listens for its data at both the current modulation and the requested, more robust, modulation. Because the CPEs 104 receive all data transmitted by the base station 102, a change in modulation will be evident to a specific CPE 104 when data is received in the requested modulation scheme. Flow then returns to block 702.

Returning to decision block 710, if the downlink quality has not exceeded the upper modulation threshold 410, flow proceeds to block 702.

FIG. 8 is a flowchart illustrating the process of adaptively adjusting uplink modulation scheme. A specific CPE's 104 can change its uplink modulation independent of that CPE's 110 downlink modulation. The specific CPE's modulation

can also be independent of the uplink modulation schemes used by other CPEs 104 within the same sector 106. Because the base station 102 must synchronize with each individual CPE 104 that uplinks data, the uplink quality may be different than the downlink quality with a specific CPE 104. In one embodiment the base station 102 performs the process to adaptively adjust the uplink modulation scheme used by a specific CPE 104. As such, a similar process may be completed for each CPE 104 within the sector 106 in order to adaptively adjust each CPEs 104 uplink modulation.

In particular, flow begins in start block 800. Flow proceeds to block 802, where the quality of the uplink 112 from a CPE 104 to a base station 102 is determined. The quality of the uplink may be a function of the state of the transmission medium (e.g. air, foggy air, wet air, smoky air, etc.) and the ability of both the transmitting and receiving components (e.g. CPE 104 and base station 102) to respectively transmit and receive data. In one embodiment, the base station 102 determines the quality of each uplink 112(a)-(c). In another embodiment, the base station 102 periodically transmits measurements, which are indicative of the quality of a CPE's uplink 112, to that CPE 104. The CPE 104 then uses these measurements to determine the quality of its uplink. These measurements can include SNR and/or BER measurements of the uplink 112(a)-(c). For example, base station 102 can determine the quality of uplink 112(c) based on a measurement by its SNR module 206 (see FIG. 2). A single SNR measurement or a series of several SNR measurements taken during a frame 300 (see FIG. 3) or during multiple frames may be used to determine the uplink quality. In embodiments which include a processor 210 (see FIG. 2), multiple measurements are analyzed by the processor 210 to determine the uplink's quality. For example, SNR measurements may be averaged over N frames 300 to generate the uplink quality measurement. In one embodiment, base station 102 transmits its measurements to a CPE 104 for analysis by a processor 210. The CPE 104 then determines the quality of its uplink.

Continuing to block 804, the base station or CPE compares the calculated uplink quality with the current modulation thresholds, as shown in FIGS. 4 and 5. The current modulation thresholds are an upper threshold 410 and a lower threshold 412 at which the modulation scheme is changed. With reference to FIG. 5, the current modulation thresholds for a QAM-64 transmission are QAM-64 upper threshold 410(c) and QAM-64 lower threshold 412(b). For example, if CPE 104(a) is currently uplinking data to base station 102 using QAM-64 modulation, the modulation scheme will change when the uplink quality exceeds the upper threshold 410(c) at 38 dB or goes below lower threshold 412(b) at 12 dB. Furthermore, the modulation scheme will not be changed when link quality crosses either QAM-256 lower threshold 412(c) or QAM-16 upper threshold 410(b) because they are not current modulation thresholds.

Next at decision block 806, the CPE determines whether the uplink quality has decreased and crossed a modulation lower threshold 412 (see FIG. 4) according to the comparison made in block 804. With reference to FIG. 5, when the modulation is QAM-256 the current modulation lower threshold 412(c) is 32 dB. For QAM-64, the current modulation lower threshold 412(b) is 12 dB. For QAM-16, the current modulation lower threshold 412(a) is 3 dB. If the current modulation lower threshold has been crossed, flow proceeds to block 808 where a less robust modulation is selected. In embodiments where the base station determines whether the uplink quality has crossed the threshold, the

base station 102 can send a request to the CPE 104 indicating a desired uplink modulation change. Alternatively, the base station 102 can transmit an uplink map to all CPEs 104 in the downlink subframe 302 indicating which CPEs have been allotted uplink PS's and the PS's associated modulations. This allows the base station 102 to indicate to an individual CPE 104 that the modulation scheme has been changed by allotting uplink subframe 304 PSs to that CPE that uses a more robust modulation scheme. For example, if the uplink modulation for CPE 104(a) is to be changed from QAM-64 to QAM-16, the base station 102 assigns uplink subframe PS's which are to be modulated using QAM-16. This uplink assignment serves as an indicator to the CPE that its uplink modulation scheme has been change. Flow then returns to block 802.

Returning to decision block 806, if a current modulation lower threshold has not been crossed, flow proceeds to decision block 810 where the system determines whether the uplink quality has crossed an upper modulation threshold 410. With reference to FIG. 5, when the current modulation is QAM-64 the current modulation upper threshold 410(c) is 38 dB. For QAM-16, the current modulation upper threshold 410(b) is 17 dB. For QPSK, the current modulation upper threshold 410(a) is 5 dB. If the current modulation upper threshold has been exceeded, flow continues to block 812 where the modulation scheme is changed to a less robust, denser modulation. In one embodiment, the base station 102 sends a request to the CPE 104 indicating a desired uplink modulation change. In another embodiment, the base station 102 transmits an uplink map to all CPEs 104 in the downlink subframe 302 indicating which CPEs have been allotted uplink PS's and the PS's associated modulations. The base station 102 indicates to an individual CPE 104 that the modulation scheme has been changed by allotting uplink subframe 304 PSs to that CPE that uses a less robust modulation scheme. For example, if the uplink modulation for CPE 104(a) is to be changed from QAM-16 to QAM-64, the base station 102 assigns uplink subframe PS's which are to be modulated using QAM-64. This uplink assignment serves as an indicator to the CPE that its uplink modulation scheme has been change. Flow then returns to block 802.

Returning to decision block 810, if the downlink quality has not exceeded the upper modulation threshold 610, flow proceeds to block 802.

The foregoing description details certain embodiments of the invention. It will be appreciated, however, that no matter how detailed the foregoing appears in text, the invention can be practiced in many ways. As is also stated above, it should be noted that the use of particular terminology when describing certain features or aspects of the embodiments should not be taken to imply that the terminology is being re-defined herein to be restricted to including any specific characteristics of the features or aspects of the embodiment with which that terminology is associated. The scope of the embodiments should therefore be construed in accordance with the appended claims and any equivalents thereof.

What is claimed is:

1. A wireless communication system for determining a plurality of uplink modulation schemes and a plurality of downlink modulation schemes for use in a wireless communication system including a base station and a plurality of customer premises equipment (CPE), where each of the plurality of uplink and downlink modulation schemes used by each of the plurality of CPE can be asymmetric, such that the uplink modulation scheme may be different than the downlink modulation scheme, the system comprising:

a plurality of CPE, each including a first modem configured to measure a first link quality based on received downlink data;

US 6,549,759 B2

15

- a base station having a second modem configured to measure a second link quality for each of the plurality of CPE based on received uplink data;
- a first processor configured to receive the first link quality and determine a downlink modulation scheme for each of the plurality of CPE; and
- a second processor configured to receive the second link quality and determine an uplink modulation scheme for each of the plurality of CPE.
2. The system of claim 1, wherein the first processor is located at each of the plurality of CPE.
3. The system of claim 1, wherein the first processor is located at the base station to receive the first link quality from each of the plurality of CPE.
4. The system of claim 1, wherein the second processor is located at the base station.
5. The system of claim 1, wherein the second processor is located at each of the plurality of CPE to receive the second link quality from the base station.
6. The system of claim 1, wherein the first modem includes a signal to noise ratio module configured to measure the first link quality.
7. The system of claim 1, wherein the first modem includes a bit error rate module configured to measure the first link quality.
8. The system of claim 1, wherein the second modem includes a signal to noise ratio module configured to measure the first link quality.
9. The system of claim 1, wherein the second modem includes a bit error rate module configured to measure the first link quality.
10. A wireless communication system for determining an uplink modulation scheme and a downlink modulation scheme for use in a wireless communication system including a base station and at least one customer premises equipment (CPE), wherein the uplink and downlink modulation schemes are independently determined, such that the uplink modulation scheme may be different than the downlink modulation scheme, the system comprising:
- a CPE having
- a first modem configured to measure a first link quality based on received downlink data,
- a first processor configured to receive the first link quality and determine a downlink modulation scheme for the CPE; and a base station having,
- a second modem configured to measure a second link quality for the CPE based on received uplink data,
- a second processor configured to receive the second link quality and determine an uplink modulation scheme for the CPE.
11. A wireless communication system for selecting a plurality of modulation schemes for use with a base station and a plurality of customer premises equipments (CPEs), wherein physical slots in an uplink subframe of data are assigned to the plurality of CPEs by the base station, and wherein the plurality of modulation schemes are used by the plurality of CPEs to modulate data transmitted during the physical slots to the base station, the system comprising:
- a plurality of CPEs, each including a first modem configured to measure a quality value for a first physical slot of a first downlink subframe of data and transmit the quality value during a subsequent first physical slot of a first uplink subframe of data; and
- a base station including a second modem configured to receive each quality value from the plurality of CPEs and determine a modulation scheme for a second

16

- physical slot of a second downlink subframe of data for each of the plurality of CPEs, wherein the downlink modulation scheme is determined independently of a modulation scheme for a second physical slot of a second uplink subframe of data.
12. The system of claim 11, wherein the base station further includes a processor configured to determine the modulation scheme for the second physical slot of the second downlink subframe of data.
13. The system of claim 11, wherein the first modem includes a signal to noise ratio module configured to measure the quality value for the first physical slot of the first downlink subframe based on at least one signal to noise ratio measurement.
14. The system of claim 11, wherein the first modem includes a bit error rate module configured to measure the quality value for the first physical slot of the first downlink subframe based on at least one bit error rate measurement.
15. A wireless communication system for determining a first and second uplink modulation scheme and a first and second downlink modulation scheme for use in a wireless communication system including a base station and a first and second customer premises equipment (CPE), wherein the first uplink and downlink modulation schemes may be different, and the second uplink and downlink modulation schemes may be different, the system comprising:
- a first CPE configured to receive data that is modulated using a first downlink modulation scheme by a base station and including a first signal to noise ratio module configured to measure a first downlink quality for the received data, and a first processor configured to determine a revised first downlink modulation scheme based on the first downlink quality;
- a second CPE configured to receive data that is modulated using a second downlink modulation scheme by the base station and including a second signal to noise ratio module configured to measure a second downlink quality for the received data, and a second processor configured to determine a revised second downlink modulation scheme based on the second downlink quality;
- a base station having a third signal to noise ratio module configured to measure a first uplink quality for the received data from the first CPE and a second uplink quality for the received data from the second CPE, and a third processor configured to determine a first uplink modulation scheme based on the first uplink quality for the first CPE and a second uplink modulation scheme based on the second uplink quality for the second CPE.
16. A wireless communication system for determining a plurality of uplink modulation schemes and a plurality of downlink modulation schemes for use in a wireless communication system including a base station and a plurality of customer premises equipment (CPE), wherein each of the plurality of uplink and downlink modulation schemes used by each of the plurality of CPEs can be asymmetric, such that the uplink modulation scheme may be different than the downlink modulation scheme, the system comprising:
- a plurality of CPEs, each of the CPE including a first modem configured to measure a first downlink quality for data from a base station; and
- a base station having a second modem configured to measure uplink quality for transmissions from each of the plurality of CPEs, and a processor configured to determine an uplink modulation scheme for each of the CPE, wherein the processor is further configured to

17

receive the first downlink quality from the plurality of CPEs and determine a downlink modulation scheme for each CPE.

17. The system of claim 16, wherein the first modem includes a signal to noise ratio module.

18. The system of claim 16, wherein the first modem includes a bit error rate module.

19. A method for determining a plurality of uplink modulation schemes and a plurality of downlink modulation schemes for use in a wireless communication system which communicates with frames of data and includes a base station and a plurality of customer premises equipment (CPEs), wherein each of the plurality of uplink and downlink modulation schemes used by each of the plurality of CPEs can be asymmetric, such that the uplink modulation scheme may be different than the downlink modulation scheme, the method comprising:

determining an uplink quality for a first frame of data transmitted by a CPE and received by a base station; comparing the determined first uplink quality to a plurality of modulation threshold values;

if the first uplink quality has crossed one of the plurality of modulation thresholds selecting a second uplink modulation scheme for the CPE;

receiving a request for the second uplink modulation scheme at the CPE;

determining a downlink quality for a second frame of data transmitted by the base station and received by the CPE;

comparing the determined first downlink quality to a second plurality of modulation threshold values;

if the first downlink quality has crossed one of the plurality of modulation thresholds, selecting a second downlink modulation scheme for the CPE;

18

receiving a request for the second downlink modulation scheme at the base station;

transmitting a third frame of data by the base station to the CPE using the second downlink modulation scheme;

transmitting a fourth frame of data by the base station using the second uplink modulation scheme.

20. The method of claim 19, wherein determining the uplink quality is accomplished using at least one signal to noise ratio ("SNR") measurements for the first frame of data.

21. The method of claim 20, wherein the at least one SNR measurements are averaged in order to determine the uplink quality.

22. The method of claim 19, wherein determining the downlink quality is accomplished using at least one signal to noise ratio ("SNR") measurements for the second frame of data.

23. The method of claim 22, wherein the at least one SNR measurements are averaged in order to determine the downlink quality.

24. The method of claim 19, further comprising sending the selected second uplink modulation scheme by the base station to the CPE within an uplink frame map.

25. The method of claim 19, further comprising sending a request for the selected second downlink modulation scheme by the CPE to the base station.

26. The method of claim 25, further comprising sending a confirmation by the base station to the CPE in response to the request for the second downlink modulation.

27. The method of claim 25, further comprising recognizing the second downlink modulation in the third frame of data by the CPE.

* * * * *