

Randall B. Bateman (USB 6482)
Perry S. Clegg (USB 7831)
BATEMAN IP LAW GROUP
8 East Broadway, Suite 550
P.O. Box 1319
Salt Lake City, UT 84110
Tel: (801) 533-0320/Fax: (801) 533-0323

FILED
U.S. DISTRICT COURT
2006 JUL -7 P 4: 11
DISTRICT OF UTAH
BY: _____
DEPUTY CLERK

Attorneys for Plaintiff

UNITED STATES DISTRICT COURT

DISTRICT OF UTAH, NORTHERN DIVISION

HARK'N TECHNOLOGIES, LTD.,
a North Carolina corporation,

Plaintiff,

vs.

GREATER PERFORMANCE, INC.,
a Missouri corporation,

Defendant.

**COMPLAINT
AND JURY DEMAND**

Judge Dale A. Kimball
DECK TYPE: Civil
DATE STAMP: 07/07/2006 @ 16:11:44
CASE NUMBER: 1:06CV00077 DAK

COMES NOW Plaintiff, Hark'n Technologies, Ltd., and complains against Defendant Greater Performance, Inc. as follows:

PARTIES, JURISDICTION & VENUE

1. Plaintiff, Hark'n Technologies, Ltd. ("HARK'N") is a corporation organized under the laws of the State of North Carolina having a business address in Clearfield, Utah.
2. Defendant, Greater Performance, Inc. ("GPI") is a corporation organized under the laws of the State of Missouri, having a business address in Cameron, Missouri.

3. On information and belief, GPI has sold, offered for sale, and continues to offer for sale, within the State of Utah, products that infringe a United States Letters Patent owned by Plaintiff. GPI also maintains an interactive website at www.speedster.com that offers for sale (and through which anyone can purchase) infringing products.

4. This action arises under the patent laws of the United States, Title 35, United States Code. This Court has jurisdiction over the patent claims under 28 U.S.C. §§ 1331 and 1338(a). Venue is proper in this district by virtue of Title 28 U.S.C. §§ 1391 & 1400.

GENERAL ALLEGATIONS

5. HARK'N is the owner of United States Letters Patent No. 6,202,263 ("the '263 Patent"), filed on July 19, 1999 and issued on, March 20, 2001, for a Safety Sleeve Elastic Device. A copy of the '263 Patent is attached hereto and expressly incorporated as Exhibit A.

6. The '263 Patent relates to technology to improve safety of elastic devices commonly used for athletic training.

7. Defendant, GPI manufactures, sells and offers for sale athletic equipment, including equipment used in speed training that incorporates elastic devices.

8. On November 30, 2001, Defendant submitted to the United States Patent and Trademark Office ("USPTO") a Request for Ex Parte Reexamination of the '263 Patent.

9. During the re-examination process, Defendant sought to invalidate the '263 Patent on the basis of prior art.

10. The USPTO affirmed the validity of most claims of the '263 patent and found 57 additional claims patentable over the cited prior art. A copy of the Ex Parte Reexamination Certificate is attached hereto and expressly incorporated as Exhibit B.

11. The '263 Patent is valid and enforceable.

12. Defendant, GPI currently sells a product known as the Speedster Lightning Cord. The Speedster Lightning Cord, as presently manufactured and offered for sale, has all of the elements of one of more claims of the '263 Patent. A copy of selected pages from Defendant's interactive website showing the Speedster Lightning Cord being offered for sale is attached hereto as Exhibit C.

13. HARK'N earns considerable sums through the sales of athletic equipment using safety sleeve elastic devices made in accordance with the invention disclosed in the '263 Patent.

14. Defendant is aware of the '263 Patent.

15. On information and belief, GPI makes, uses, sells, or offers to sell athletic equipment having a safety sleeve elastic device which falls within the scope of the invention set forth and claimed in the '263 Patent and has made, used, sold or offered for sale said infringing athletic equipment within the State of Utah.

FIRST CLAIM FOR RELIEF
(Direct Infringement, 35 U.S.C. §271(a))

16. Plaintiff Hark'n Technologies, Ltd. incorporates herein each and every allegation of paragraphs 1 through 15 of this Complaint.

17. The '263 Patent has at all times subsequent to its issue date been fully enforceable and is now fully enforceable.

18. HARK'N is the owner of record and holds all rights under the '263 Patent, including the right to sue for infringement.

19. GPI has made, used, sold or offered to sell safety sleeve elastic devices that come within the scope of one or more claims of the '263 Patent.

20. GPI has within the State of Utah made, used, sold, or offered to sell safety sleeve elastic devices that come within a range of equivalents of the claims of the '263 Patent.

21. The making, using, or selling of infringing safety sleeve elastic devices by GPI has been without authority or license from HARK'N and in violation of HARK'N's rights, thereby infringing the '263 Patent.

22. The making, using, selling or offering to sell safety sleeve elastic devices that fall within the scope of the '263 Patent by GPI has been with knowledge of the '263 Patent, and in disregard for the exclusive rights of HARK'N.

23. The amount of money damages which HARRK'N has suffered due to GPI's acts of infringement cannot be determined without an accounting, and is thus subject to proof at trial. Further, harm to HARK'N arising from GPI's acts of infringement is not fully compensable by money damages. Rather, HARK'N has suffered, and continues to suffer, irreparable harm which has no adequate remedy at law and which will continue until GPI's conduct is enjoined.

SECOND CLAIM FOR RELIEF
(Inducement, 35 U.S.C. §271(b))

24. HARK'N incorporates herein each and every allegation of paragraphs 1 through 23 of this Complaint.

27. On information and belief, GPI has actively induced, and is now inducing, infringement of the '263 Patent.

28. GPI has unlawfully derived, and continues to unlawfully derive income and profits by inducing others to infringe the '263 Patent. HARK'N has suffered, and continues to suffer, damages as a result of GPI's inducement to infringe the '263 Patent.

29. HARK'N has suffered, and will continue to suffer irreparable damage for which there is no adequate remedy at law because of GPI's inducement of others to infringe, and will continue to be harmed unless GPI is enjoined from further acts of inducement.

PRAYER FOR RELIEF

WHEREFORE, Plaintiff HARK'N prays for judgment against Defendant GPI as follows:

A. The Court adjudge United States Letters Patent No. 6,202,263 valid and infringed by GPI;

B. For damages in an amount to be determined at trial, said damages being not less than a reasonable royalty;

C. For a finding that GPI acted willfully in its infringement of the '263 Patent, and for an award of treble damages pursuant to U.S.C. §284.

D. That GPI, its agents, servants, employees, directors, and those persons in active concert or participation with it be enjoined under 35. U.S.C. §283 from further violation of HARK'N's patent rights or such terms as the Court deems reasonable;

E. That GPI be ordered to file with this Court and serve on HARK'N within thirty (30) days after service on GPI of the injunction granted herein, or such extended period as the Court may direct, a report in writing, under oath, setting forth in detail the manner and form in which GPI has complied with the injunction and order of the Court;

F. That GPI be order to pay HARK'N's attorney's fees and its costs and disbursements for this action under 35 U.S.C. §285;

G. That GPI be required to pay pre-judgment and post-judgment interest until such awards are paid;

J. That HARK'N has such other and further relief as shall seem just and proper to the Court.

DEMAND FOR JURY

Plaintiff Hark'n Technologies, Ltd. hereby requests a trial by jury in the above-captioned action.

Dated: July 7, 2006

BATEMAN IP LAW GROUP

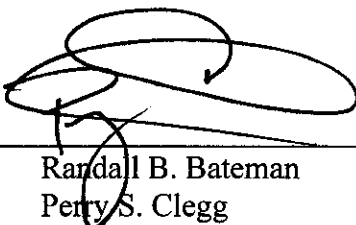
By  _____
Randall B. Bateman
Perry S. Clegg

Attorneys for Plaintiff
Hark'n Technologies, Ltd.

EXHIBIT A



US006202263B1

(12) **United States Patent**
Harker

(10) **Patent No.:** US 6,202,263 B1
(45) **Date of Patent:** Mar. 20, 2001

(54) **SAFETY SLEEVE ELASTIC DEVICE**

(76) **Inventor:** Shon Les Harker, 1425 S. 2469 West, Syracuse, UT (US) 84075

(*) **Notice:** Subject to any disclaimer, the term of this patent is extended or adjusted under 35 U.S.C. 154(b) by 0 days.

(21) **Appl. No.:** 09/353,533

(22) **Filed:** Jul. 14, 1999

Related U.S. Application Data

(60) Provisional application No. 60/093,020, filed on Jul. 16, 1998.

(51) **Int. Cl.⁷** A44B 13/02; F16G 11/00

(52) **U.S. Cl.** 24/300; 24/715.3; 24/482; 114/230; 2/237

(58) **Field of Search** 24/300, 715.3, 24/482; 2/237

(56) **References Cited**

U.S. PATENT DOCUMENTS

2,820,269	*	1/1958	Wolf	24/300
4,559,677	*	12/1985	Tracy	24/300
4,653,422	*	3/1987	Allen	24/300
4,694,541	*	9/1987	Skyba	24/300

4,817,551	*	4/1989	Matson	114/230
5,317,788	*	6/1994	Esposito et al.	24/300
5,546,639	*	8/1996	Lacore et al.	24/300
5,638,584	*	6/1997	De Anfrasio	24/300
5,816,458	*	10/1998	Yoneno	24/300
6,085,628	*	7/2000	Street et al.	87/7

* cited by examiner

Primary Examiner—Victor N. Sakran

(74) *Attorney, Agent, or Firm*—Madson & Metcalf

(57) **ABSTRACT**

The present invention provides a unique safety sleeve elastic device having an elastic member of a certain longitudinal length. The elastic member provides stretching capability of up to seven times the elastic member's original length depending on the material selected. A flexible sleeve member is disposed around the elastic member. The sleeve member is less elastic than the elastic member and provides a stretch limitation to the elastic member to prevent a user from stretching the elastic member beyond a safe elongation. The ends of the sleeve and elastic members are secured proximate to one another. The ends of the elastic members are further secured to connectors. The elastic member provides stretch capability while the sleeve member provides safety features to protect the elastic member and the user.

17 Claims, 4 Drawing Sheets

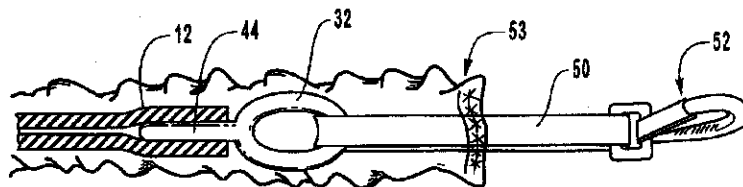
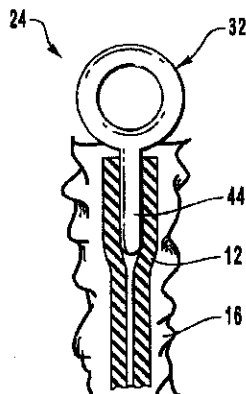

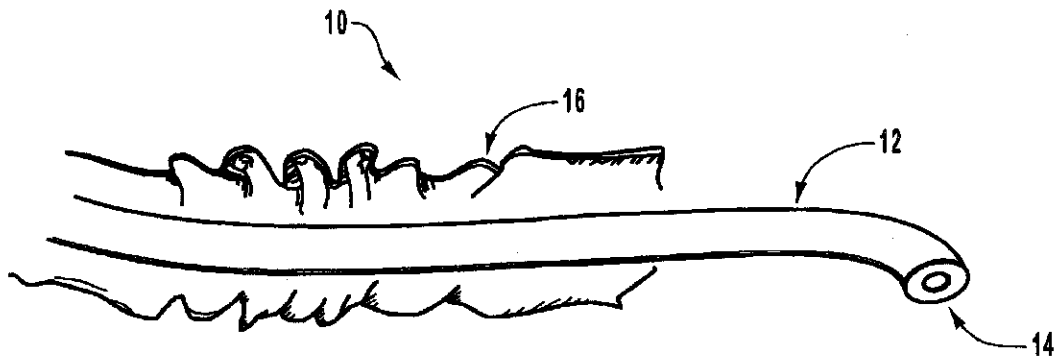

FIG. 1

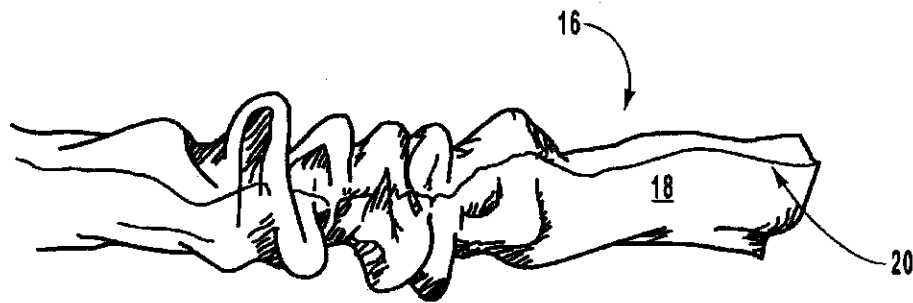

FIG. 2

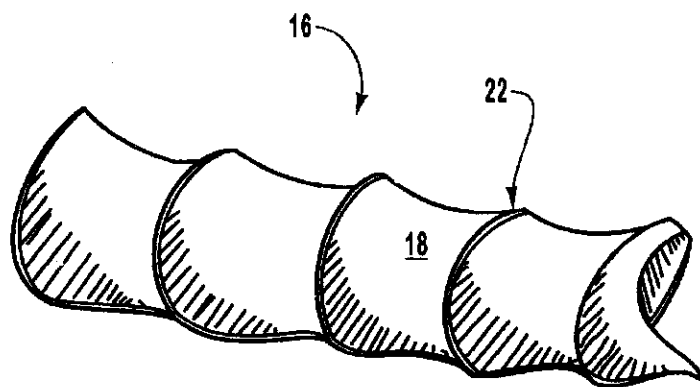

FIG. 3

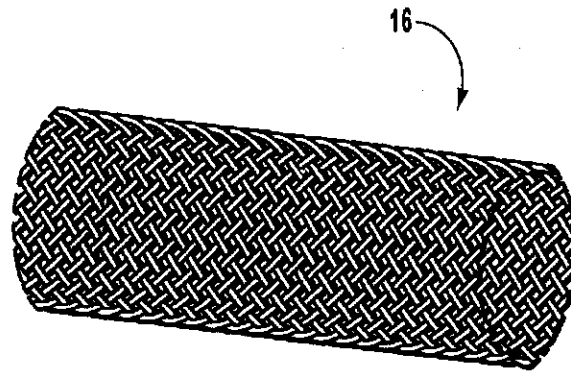

FIG. 4A

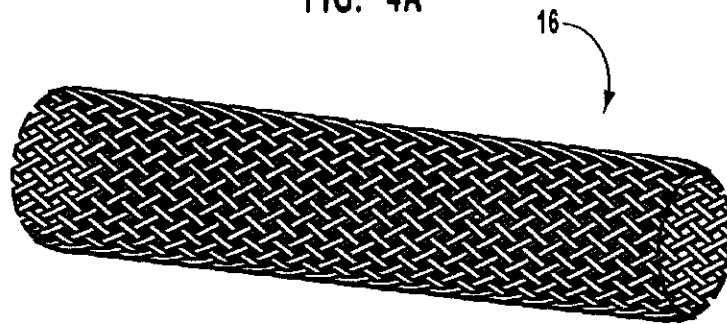

FIG. 4B

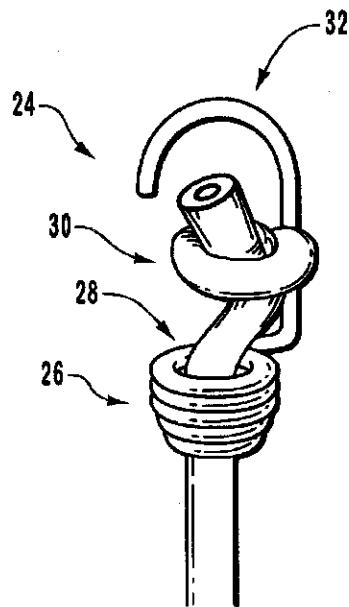

FIG. 5

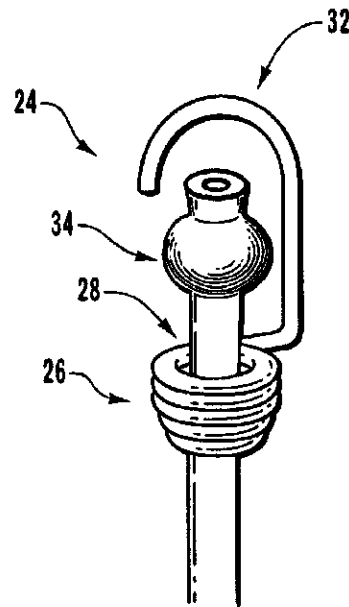

FIG. 6

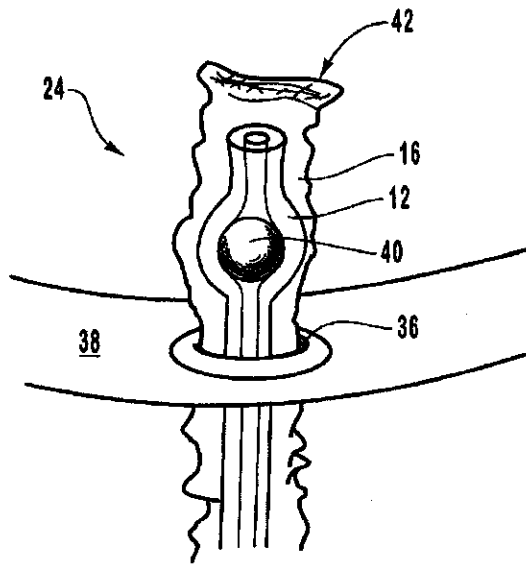

FIG. 7

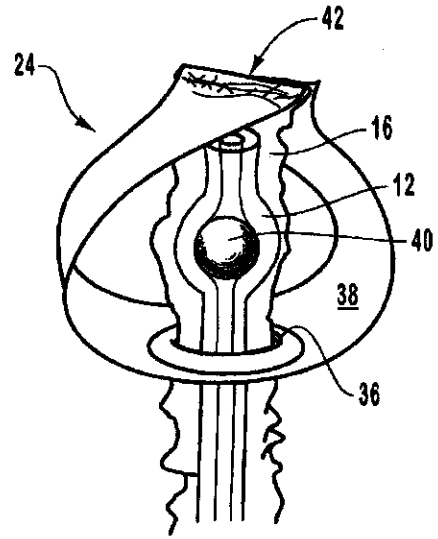

FIG. 8

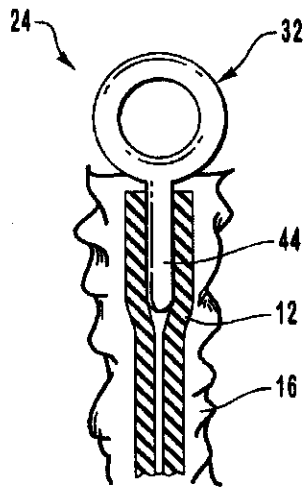

FIG. 9

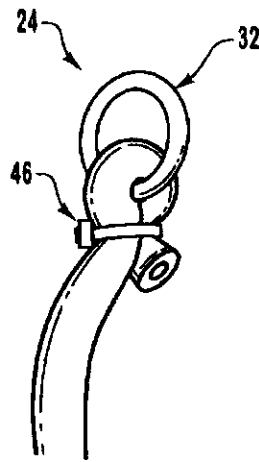

FIG. 10

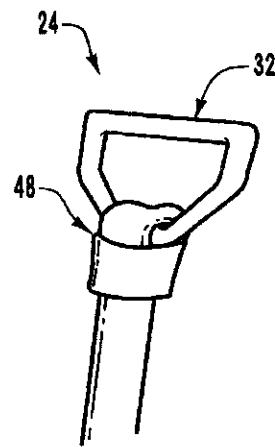

FIG. 11

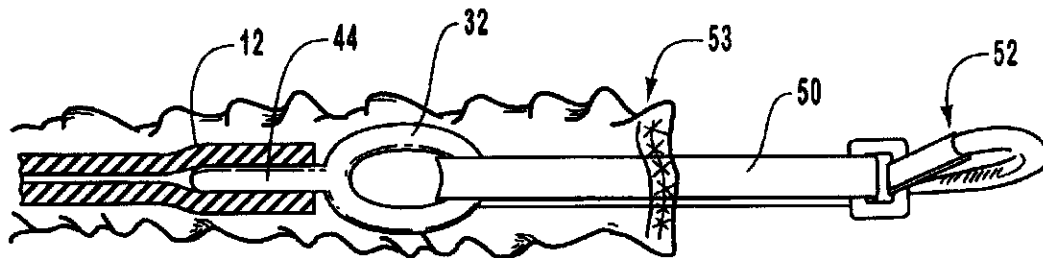

FIG. 12

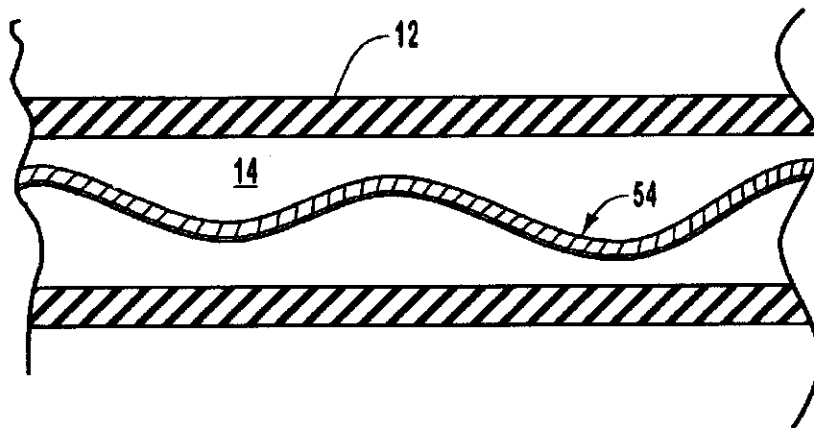

FIG. 13

US 6,202,263 B1

1

SAFETY SLEEVE ELASTIC DEVICE**RELATED APPLICATION**

This application claims priority to Provisional Patent Application Serial No. 60/093,020, filed Jul. 16, 1998.

BACKGROUND**1. The Field of the Invention**

The present invention relates to a stretchable device for use in a variety of applications including physical exercise.

2. The Background Art

Stretchable members have numerous applications for use in fastening, bundling, and otherwise generally containing objects. The stretch ability of such members makes them ideal for such purposes. Stretchable members also have application in exercising. The durability and stretch resistance of certain stretchable members makes them ideal for repetitive movements required in exercising.

One common stretchable member known in the art is the bungee cord. A typical bungee cord is comprised of multiple stretchable rubber fibers or strands throughout the center. A fabric is then woven around the rubber fibers. During manufacture of a bungee cord, the elastic strands are pulled through a loom that weaves the external fabric around it. Without the exterior fabric the elastic strands would fall out. The exterior fabric stays in full contact with the interior rubber fibers at all times during the stretch.

Because of the manufacturing techniques, the internal material used, and the weave of the external fabric, the bungee cord technology has limits. In practice, the maximum stretch of a bungee cord is about twice its original length. In practice, a bungee cord generally has a maximum stretch of only 1.5 to 1.75 times its original length.

Another stretchable member known in the art incorporates an elastic within an elastic. In this approach, a small tubular elastic is threaded through an identical but larger tubular elastic. Both elastics are commonly of the same material. If one elastic or the other were to break it would keep both elastics contained together. However, the use of two members of the same material does not substantially limit the stretch. Thus, the members are susceptible to stretching beyond a safe limit. This may result in breaking of the members and possible injury to the user.

Another approach in the art is the use of an elastic and rope in combination. In this approach, an elastic has a rope spiraled along the exterior length of the elastic. The rope is then attached to the eyelets at the end of the elastic. A disadvantage with this approach is the entanglement of the rope which hinders the function of the stretchable member. A further disadvantage is that if the elastic breaks the user may be injured by the whiplash of the elastic.

The prior art suffers from having limited stretching capability and not having a safety limitation to prevent undue stretching. Thus, it is an object of the invention to provide a stretching device with superior stretching capability and safety features to protect the device and the user. These advantages of the present invention will become more fully apparent by examination of the following description of the preferred embodiments and the accompanying drawings.

BRIEF SUMMARY OF THE INVENTION

The present invention provides a unique safety sleeve elastic device having an elastic, elastic member of a certain longitudinal length. The elastic member is preferably

2

formed of a latex material, but one of skill in the art will appreciate that other elastic materials may be used as well. The invention further comprises a flexible sleeve member disposed around the elastic member. The sleeve member is less elastic than the elastic member and may be formed of polypropylene and nylon materials. The ends of the sleeve member and the ends of the elastic member are secured proximate to one another.

The ends of the elastic member and the sleeve member are secured to connectors. The connectors come in various embodiments and include clips, rings, hooks, buckles, and so forth to enable connection of the safety sleeve elastic device. Thus embodied, the safety sleeve elastic device may serve various functions including numerous applications for exercising.

The elastic member and the sleeve member act on one another to achieve the features of the present invention. The elastic member provides stretching capability of up to seven times the elastic member's original length depending on the material selected. The sleeve member has less elasticity, and may in fact have little or no elasticity, to provide a maximum allowable stretch limit. Thus, a user is prevented from stretching the elastic member beyond a safe elongation.

The sleeve member acts to protect the elastic member from wear and contact which may damage the elastic member. The sleeve member protects a user by retaining the elastic member within is interior. Thus, if the elastic member breaks a user is not harmed by whiplash. Furthermore, skin irritation from the material of the elastic member is eliminated.

Thus, it is an object of the present invention to provide a stretchable device suitable for repetitive exercises having superior stretch capability while incorporating safety features to protect the device and the user.

Such a device is disclosed and claimed herein.

BRIEF DESCRIPTION OF THE DRAWINGS

In order that the manner in which the above-recited and other advantages and features of the invention are obtained, a more particular description of the invention summarized above will be rendered by reference to the appended drawings. Understanding that these drawings only provide selected embodiments of the invention and are, therefore, not to be considered limiting of its scope, the invention will be described with additional specificity and detail through use of the accompanying drawings in which:

FIG. 1 is partial cross-sectional view of one presently preferred embodiment of the safety sleeve elastic device of the present invention;

FIG. 2 is a perspective view of one embodiment of the sleeve member of the safety sleeve elastic device of the present invention;

FIG. 3 is perspective view of an alternative embodiment of the sleeve member of the safety sleeve elastic device of the present invention;

FIG. 4A is a perspective view of an alternative embodiment of the sleeve member of the safety sleeve elastic device of the present invention;

FIG. 4B is a perspective view of the sleeve member of the embodiment of FIG. 4A.

FIG. 5 is a perspective view of one embodiment of an end attachment of the safety sleeve elastic device of the present invention;

FIG. 6 is a perspective view of an alternative embodiment of the end attachment of the safety sleeve elastic device of the present invention;

US 6,202,263 B1

3

FIG. 7 is a perspective view of an alternative embodiment of the end attachment of the safety sleeve elastic device of the present invention;

FIG. 8 is a perspective view of the end attachment of the embodiment of FIG. 7;

FIG. 9 is a side view of an alternative embodiment of the end attachment of the safety sleeve elastic device of the present invention;

FIG. 10 is a perspective view of an alternative embodiment of the end attachment of the safety sleeve elastic device of the present invention

FIG. 11 is a perspective view of an alternative embodiment of the end attachment of the safety sleeve elastic device of the present invention;

FIG. 12 is a perspective view of an alternative embodiment of the end attachment of the safety sleeve elastic device of the present invention; and

FIG. 13 is a side view of an alternative embodiment of the safety sleeve elastic device of the present invention.

DETAILED DESCRIPTION OF THE PREFERRED EMBODIMENTS

The presently preferred embodiments of the present invention will be best understood by reference to FIGS. 1 through 13 wherein like parts are designated by like numerals throughout. It will be readily understood that the components of the present invention, as generally described and illustrated in the figures herein, could be arranged and designed in a wide variety of different configurations. Thus, the following more detailed description of the embodiments of the apparatus, system, and method of the present invention, as represented in FIGS. 1 through 13, is not intended to limit the scope of the invention, as claimed, but is merely representative of presently preferred embodiments of the invention.

In one presently preferred embodiment as shown in FIG. 1, the safety sleeve elastic device is shown and generally designated as 10. The device 10 comprises a flexible, stretchable elastic member 12. The elastic member 12 is configured to have a certain longitudinal length and first and second ends. In one embodiment, the elastic member 12 is configured in a tubular shape having an inner cavity 14 which traverses the longitudinal length of the elastic member 12.

The elastic member 12 is formed of an elastic material which is defined herein as a material which is capable of returning to an original length or shape after being stretched. In one embodiment, the elastic material comprises latex. In such an embodiment, the elastic member 12 may have a stretch of up to seven times its original length. Latex materials have great elongation abilities with a material memory that allows it to return to nearly its original length even after repetitive use. Such capability is advantageous for exercise equipment.

In alternative embodiments, the elastic material may comprise non-latex materials including natural rubber. Such alternative materials may be sufficient provided that they are capable of stretch and retraction. However, generally such materials do not provide for the superior stretch afforded by latex based materials.

The device 10 further comprises a sleeve member 16 which is hollow along its longitudinal length to surround or nearly surround the elastic member 12 along the longitudinal length of the device 10. The sleeve member 16 loosely fits around the elastic member 12 to allow the elastic member 12

4

to expand or contract within the sleeve member 16. The sleeve member 16 is sufficiently flexible to allow the elastic member 12 to bend.

The sleeve member 16 is further configured to be less elastic than the elastic member 12 and therefore does not stretch as far as the elastic member 12. The sleeve member 16 may provide some stretch based on the materials forming the sleeve member 16. In one embodiment, the sleeve member 16 may comprise a fabric formed of polypropylene or nylon fibers. The fibers may be assembled in a weave pattern. In such an embodiment, the weave pattern itself allows for some stretch. In one embodiment, the sleeve member 16 is formed of a fabric which provides little or no stretch.

The sleeve member 16 is preferably of a stronger material than the elastic member 12, such as the previously mentioned polypropylene or nylon materials. The ends of the sleeve member 16 are secured proximate to the ends of the elastic member 12. In one embodiment, this is done by attaching the ends of the sleeve member 16 to the elastic member 12 at or near corresponding ends of the elastic member 12. So embodied, the sleeve member 16 provides a stretch limitation to the elastic member 12. Thus, the elastic member 12 is protected from stretching beyond a breaking limit.

In one embodiment, the sleeve member 16, has a greater longitudinal length than the elastic member 12. When the elastic member 12 is at rest, the sleeve member 16 is compressed so that it terminates generally at the same ends of the elastic member 12. The elastic member 12 may be stretched until the sleeve member 16 extends to its full longitudinal length. When the sleeve member 16 extends to its full length the sleeve member 16 begins to restrict the stretch of the elastic member 12. The sleeve member 16 is selected of a certain length and material to allow stretching of the elastic member 12 to lengths appropriate for the elastic member 12. Thus, the device 10 may be stretched up to seven times its original length based on the capability of the elastic member 12.

The sleeve member 16 protects the elastic member 12 by covering the elastic member 12 and preventing contact with the elastic member 12. The elastic member 12 is preferably formed of a relatively soft material which is susceptible to damage. Exercise equipment is often exposed to rough surfaces and it is advantageous to provide such protection to the equipment.

The sleeve member 16 further protects a user from exposure to the elastic member 12. Latex may cause skin irritation. Thus, with the sleeve member 16 the user does not have direct contact with the elastic member 12.

Referring to FIG. 2, one embodiment for the sleeve member 16 is shown. In this embodiment, the sleeve member 16 is made of a thin material such as a fabric 18. The fabric 18 may comprise fibers of polypropylene or nylon. The fabric 18 of the sleeve member 16 may be formed with a seam 20 to thereby form a cylindrical shape for housing the elastic member 12. The seam 20 may be formed by sewing, applying adhesives, or by a heat seal. Thus embodied, the sleeve member 16 may be compressed to partially fold onto itself.

Referring to FIG. 3, an alternative embodiment for the sleeve member 16 is shown. The sleeve member 16 comprises a spiral member 22, such as a wire, that extends substantially along the longitudinal length of the sleeve member 16 and provides reinforcement to the fabric 18. The spiral member 22 may be compressed or extended to a

US 6,202,263 B1

5

certain length. The sleeve member 16 of this embodiment will still limit the stretch of the elastic member 12 because of the limited stretch of the fabric. This embodiment of the sleeve member 16 is similar to conventional clothes dryer connectors.

Referring to FIGS. 4A and 4B, an embodiment for the sleeve member 16 is shown. In this embodiment, the sleeve member 16 is formed of fibers weaved to allow the material to expand or contract. Accordingly, the sleeve member 16 has some stretch capability but not as much as the elastic member 12. The embodiment of FIG. 4 is similar in concept to the bungee cord fabric exteriors, Chinese thumb handcuffs, and some wire cable protection coatings.

The device 10 of the present invention may be used with end attachments or connectors. The elastic member 12 and sleeve member 16 are configured to generally terminate at these end attachments. Preferably, a connector is used for each end of the elastic and sleeve members 12, 16. Various embodiments for end attachments may be used with the device and include rings, clips, fasteners, and may be made of plastic or metal. In one embodiment, the ends of the sleeve member 16 are secured to the connectors. The ends of the elastic member 12 are then secured to the connectors and the sleeve member 16 provides a stretch limitation to the elastic member 12.

Referring to FIG. 5, one embodiment for an end attachment of connector 24 is shown and is referred to herein as a "knot." The connector 24 comprises a base 26 having an eye or aperture 28. The elastic member 12 passes through the eye 28. The elastic member 12 is tied into a knot 30. The knot 30 has a cross-section larger than the eye 28 to prevent pull back through the eye 28 of the connector 24.

The connector 24 further comprises an attachment member 32 to enable connection to another object. The attachment member 32 may be a hook as shown in FIG. 5 or may be embodied as a ring, clip, buckle, or other fastener.

The sleeve member 16 (not shown) may also pass through the eye 28 to thereby secure the sleeve member 16 as well. Alternatively, the end of the sleeve member 16 may be secured to the connector 24 by wrapping, tying, sewing, or using adhesives.

Referring to FIG. 6, an alternative embodiment for a connector 24 is shown which is herein referenced to herein as a "crimp." This technique is similar to the knot in FIG. 5 except that a rigid collar 34 is employed. The rigid collar 34 crimps around the elastic member 12 after the member 12 has passed through the eye 28. The collar 34 has an outer diameter greater than that of the aperture 28 to prevent pull back of the members 12.

The sleeve member 16 (not shown) may also pass through the eye 28 and be secured with the rigid collar 34. Alternatively, the end of the sleeve member 16 may be secured to the connector 24 by wrapping, tying, sewing, or using adhesives.

Referring to FIGS. 7 and 8, an alternative embodiment for a connector 24 is shown. In this embodiment, the elastic member 12 passes through an eyelet or aperture 36 of an end member 38. The end member 38 may be embodied as a strap of fabric. A rigid object 40, such as a ball, is pressed inside the elastic member 12 as shown. The rigid object's diameter 40 is greater than the diameter of the inner cavity 14 of the elastic member 12. The elastic member 12 has a greater diameter at the location of the rigid object 40 than the aperture 36 and can no longer pass through the aperture 36 in one direction.

The sleeve member 16 also passes through the aperture 36 along with the elastic member 12. The sleeve member 16 is

6

shown connected together at its end 42 above the aperture 36 so that the rigid object 40 and the elastic member 12 together impede the sleeve member 16 from pulling through the aperture 36. Opposing ends of the end member 38 may be connected to one another at the end 42 of the sleeve member 16 to thereby secure the end member 38.

Referring to FIG. 9, an alternative embodiment for a connector 24 is shown and is referred to herein as a "tie-on." In this embodiment, the connector 24 comprises a base member 44 such as a stem or shaft. The base member 44 is attached to an attachment member 32 such as a hook or ring. The base member 44 and attachment member 32 may be incorporated into one integral piece. The base member 44 has a diameter greater than the inner cavity 14 of the elastic member 12. The base member 44 is pressed into the inner cavity 14 and the resulting tension holds the base member 44 in place. The sleeve member 16 is then wrapped, tied, or sewn around the connector 24 to secure the sleeve member 16.

Referring to FIG. 10, an alternative embodiment for a connector 24 is shown and is referred to herein as a "synch tie." In this embodiment, the elastic member 12 passes through an attachment member 32 such as a ring. A clamp 46, such as a metal crimp, is secured to one end of the elastic member 12. The clamp 46 is also secured to another portion of the elastic member 12 as shown in FIG. 10 to thereby secure the connection to the attachment member 32. The sleeve member 16 (not shown) may be secured to the connector 24 by wrapping, tying, sewing, or by use of adhesives.

Referring to FIG. 11, an alternative embodiment for a connector 24 is shown and is referred to herein as a "tuck in." In this embodiment, an aperture 48 is formed in the elastic member 12 proximate to an end of the elastic member 12. The elastic member 12 passes through the attachment member 32 and is then threaded into the aperture 48 to thereby form a lasso around the attachment member 32. The sleeve member 16 (not shown) may be secured to the connector 24 by wrapping, tying, sewing, or by use of adhesives.

Referring to FIG. 12, an alternative embodiment for a connector 24 is shown and is referred to herein as a "strap extension." This embodiment utilizes a base member 44 disposed within the inner cavity 14 as in the "tie-on" embodiment. As shown, a strap 50 is then secured to the attachment member 32. A second attachment member 52 is then secured to the strap 50. The sleeve member 16 may then be wrapped, tied, sewn, or glued to the strap 50. An advantage of this embodiment is that when the sleeve member 16 and the elastic member 12 reach their stretch limit, the force at the end 53 of the sleeve member 16 transfers to the strap 50 and then to the second attachment member 52. Thus, the attachment member 32 connected to the elastic member 12 need not be as strong as the second attachment member 52.

Referring to FIG. 13, an alternative embodiment for the device 10 is shown. In this embodiment, the elastic member 12 is embodied as a latex or rubber tube. The elastic member 12 has an inner cavity 14 running along the longitudinal length of the member 12 as in previous embodiments. An inner member 54 is disposed within the inner cavity 14. The inner member 54 has less elasticity than the elastic member 12. In one embodiment, the inner member 54 may be embodied as a rope or string.

The inner member 54 is secured at both ends proximate to the ends of the elastic member 12. The inner member 54 may

US 6,202,263 B1

7

also have a greater longitudinal length than the elastic member 12. The inner member 54 provides the stretchable limitation to the elastic member 12. Obviously the embodiment of FIG. 11 does not provide the same protection of the elastic member 12 as in the embodiment of FIG. 1.

The safety sleeve elastic device 10 of the present invention is unique in that it primarily comprises two independent members 12, 16 of different materials which act upon one another. The elastic member 12 provides stretching capability in excess of 1.25 times to twice or even up to seven times the elastic member's 12 original length depending on the material selected. The sleeve member 16 provides a maximum allowable stretch limit. Often times a user will stretch an elastic member beyond a safe elongation because there is no limitation factor. When this is done, the elastic member may break and possibly injure the user. The sleeve member 16 provides added safety in that even if the elastic member 12 were to break, the elastic member 12 would retract while staying within the interior of the sleeve member 16.

The safety sleeve elastic device 10 provides elastic durability of the elastic member 12. The sleeve member 16 protects the elastic member 12 from wear and contact with sharp or rough objects which may damage the elastic member 12. Furthermore, the sleeve member 16 protects the elastic member 12 from sunlight. Sunlight increases the rate of latex deterioration. The sleeve member 16 further protects a user's skin from irritation from the material of the elastic member 12, such as latex.

It should be appreciated that the apparatus and methods of the present invention are capable of being incorporated in the form of a variety of embodiments, only a few of which have been illustrated and described above. The invention may be embodied in other forms without departing from its spirit or essential characteristics. The described embodiments are to be considered in all respects only as illustrative and not restrictive of the scope of the invention.

What is claimed and desired to be secured by united states letters patent is:

1. A stretchable apparatus, comprising:

an elastic member having first and second ends and configured to have a stretch of at least twice an original length;

a flexible sleeve member having first and second ends and disposed around the elastic member in a loose-fitting configuration, wherein the sleeve member is configured with an elasticity less than the elastic member to thereby provide a stretch limitation to the elastic member; and

first and second connectors secured to corresponding first and second ends of the elastic member, the first and second connectors further secured to corresponding first and second ends of the sleeve member.

2. The apparatus of claim 1 wherein the elastic member comprises latex.

3. The apparatus of claim 1 wherein the sleeve member comprises polypropylene fibers.

4. The apparatus of claim 1 wherein the sleeve member comprises nylon fibers.

5. The apparatus of claim 1 wherein the sleeve member comprises a spiral member disposed substantially along the longitudinal length of the sleeve member.

6. The apparatus of claim 1 wherein the first connector comprises a base having an aperture through which the elastic member passes, wherein the first end of the elastic member is configured into a knot having a cross-section larger than the aperture to thereby prevent passage of the knot through the aperture.

8

7. The apparatus of claim 1 wherein the first connector comprises:

a base having an aperture through which the elastic member passes; and

a collar disposed around the elastic member and having a diameter larger than the aperture to thereby prevent passage of the collar through the aperture.

8. The apparatus of claim 1 wherein the first connector comprises:

a rigid object disposed within the elastic member proximate to the first end of the elastic member, wherein the rigid object has a diameter greater than an internal diameter of the elastic member; and

an end member having an aperture through which the elastic member passes, wherein the diameter of the elastic member at the location of the rigid object is greater than the aperture to thereby prevent passage of the rigid object through the aperture.

9. The apparatus of claim 1 wherein the first connector comprises:

a base member at least partially disposed within the elastic member proximate to the first end of the elastic member, wherein the base member has a diameter greater than an internal diameter of the elastic member; and

an attachment member connected to the base member.

10. The apparatus of claim 1 wherein the first connector comprises:

an attachment member, wherein the first end of the elastic member extends around a portion of the attachment member; and

a clamp secured to the first end of the elastic member to thereby secure the connection of the elastic member to the attachment member.

11. The apparatus of claim 1 wherein the first connector comprises an attachment member, wherein the first end of the elastic member extends around a portion of the attachment member, and wherein the elastic member is configured with an aperture proximate to the first end, the elastic member further configured to thread through the aperture to thereby secure the connection of the elastic member to the attachment member.

12. The apparatus of claim 1 wherein the first connector comprises:

a base member at least partially disposed within the elastic member proximate to the first end of the elastic member, wherein the base member has a diameter greater than an internal diameter of the elastic member;

a first attachment member connected to the base member;

a strap having first and second ends, wherein the first end of the strap is secured to the first attachment member; and

a second attachment member is secured to the second end of the strap.

13. A method for producing a stretchable apparatus, comprising:

providing an elastic member having first and second ends and configured to have a stretch of at least twice an original length;

disposing a loose-fitting, flexible sleeve member having first and second ends around the elastic member, wherein the sleeve member has an elasticity less than the elastic member to thereby provide a stretch limitation;

securing first and second connectors to the respective first and second ends of the elastic member; and

US 6,202,263 B1

9

securing the first and second ends of the sleeve member to the first and second connectors.

14. The method of claim 13 wherein the step of securing the first and second connectors comprises:

providing an aperture in the first and second connectors; ⁵
and

passing the elastic member through the apertures in the first and second connectors.

15. The method of claim 13 wherein the step of securing the first and second connectors comprises inserting a portion of the first and second connectors into the interior of the elastic member. ¹⁰

16. A stretchable apparatus, comprising:

an elastic member having first and second ends and configured to have a stretch of at least twice an original length; ¹⁵

a flexible sleeve member having first and second ends and disposed around the elastic member in a loose-fitting configuration, wherein the sleeve member is configured with an elasticity less than the elastic member to thereby provide a stretch limitation to the elastic member, the first and second ends of the sleeve member ²⁰

10

secured to the elastic member proximate to the corresponding first and second ends of the elastic member; and

first and second connectors secured to corresponding first and second ends of the elastic member.

17. A method for producing a stretchable apparatus, comprising:

providing an elastic member having first and second ends and configured to have a stretch of at least twice an original length; ¹⁰

disposing a loose-fitting, flexible sleeve member having first and second ends around the elastic member, wherein the sleeve member has an elasticity less than the elastic member to thereby provide a stretch limitation; ¹⁵

securing the first and second ends of the sleeve member to the elastic member proximate to the corresponding first and second ends of the elastic member; and ²⁰

securing first and second connectors to the respective first and second ends of the elastic member.

* * * * *

EXHIBIT B

(12) **EX PARTE REEXAMINATION CERTIFICATE (5307th)**
United States Patent
Harker (10) **Number: US 6,202,263 C1**
 (45) **Certificate Issued: Mar. 21, 2006**

(54) **SAFETY SLEEVE ELASTIC DEVICE**
 (75) **Inventor: Shon Les Harker, Syracuse, UT (US)**
 (73) **Assignee: Hark'n Technologies, Ltd., Clearfield, UT (US)**

4,817,551 A	4/1989	Matson	
5,205,803 A *	4/1993	Zemitis	482/121
5,317,788 A	6/1994	Esposito et al.	
5,546,639 A	8/1996	Lacore et al.	
5,607,736 A *	3/1997	Williams	428/36.3
5,638,584 A	6/1997	De Anfrasio	
5,816,458 A	10/1998	Yonenoi	
6,085,628 A	7/2000	Street et al.	

Reexamination Request:
 No. 90/006,153, Nov. 30, 2001

Reexamination Certificate for:
 Patent No.: **6,202,263**
 Issued: **Mar. 20, 2001**
 Appl. No.: **09/353,533**
 Filed: **Jul. 14, 1999**

Related U.S. Application Data

(60) **Provisional application No. 60/093,020, filed on Jul. 16, 1998.**
 (51) **Int. Cl.**
A44B 13/02 (2006.01)
F16G 11/00 (2006.01)
 (52) **U.S. Cl.** **24/300; 24/715.3; 24/482; 114/230.2; 2/237**
 (58) **Field of Classification Search** **24/300, 24/715.3, 482; 482/121-131; 114/230.1, 114/230; 2/237**
 See application file for complete search history.

(56) **References Cited**
U.S. PATENT DOCUMENTS
 2,820,269 A 1/1958 Wolff
 4,559,677 A 12/1985 Tracy
 4,653,422 A 3/1987 Allen
 4,694,541 A 9/1987 Skyba

OTHER PUBLICATIONS

Brochure for "Robby GLantz International Power Skating" schools and clinics for 1995, p. 1, picture entitled, "Bungee Cords!".
 Catalogue for Sportime 1993 Fall/Winter edition, p. 23, "Buddy Band".
 Web site: <http://www.speedster.com/hockey.htm>, Sep. 17, 1996, pp. 1-3, prepared by Mark Goede for Greater Performance, Inc.

* cited by examiner

Primary Examiner—Robert J. Sandy

(57) **ABSTRACT**

The present invention provides a unique safety sleeve elastic device having an elastic member of a certain longitudinal length. The elastic member provides stretching capability of up to seven times the elastic member's original length depending on the material selected. A flexible sleeve member is disposed around the elastic member. The sleeve member is less elastic than the elastic member and provides a stretch limitation to the elastic member to prevent a user from stretching the elastic member beyond a safe elongation. The ends of the sleeve and elastic members are secured proximate to one another. The ends of the elastic members are further secured to connectors. The elastic member provides stretch capability while the sleeve member provides safety features to protect the elastic member and the user.

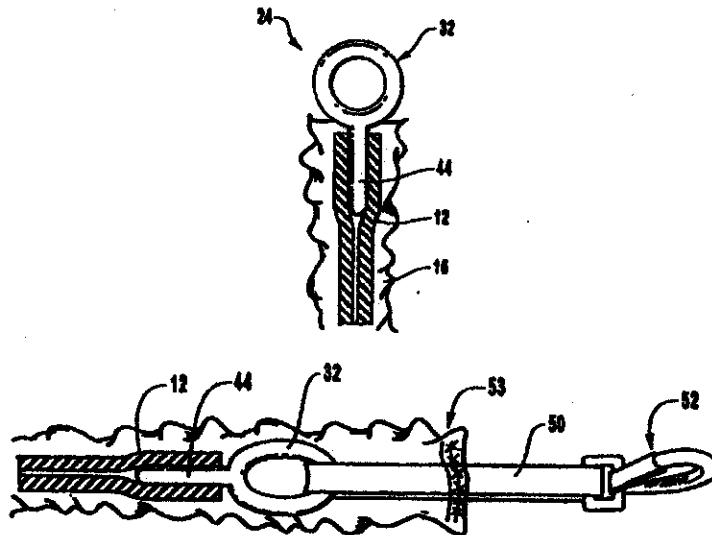

1

**EX PARTE
REEXAMINATION CERTIFICATE
ISSUED UNDER 35 U.S.C. 307**

THE PATENT IS HEREBY AMENDED AS
INDICATED BELOW.

Matter enclosed in heavy brackets [] appeared in the patent, but has been deleted and is no longer a part of the patent; matter printed in italics indicates additions made to the patent.

AS A RESULT OF REEXAMINATION, IT HAS BEEN DETERMINED THAT:

Claims 2, 3, 4, 10 and 14 are cancelled.

Claims 1, 5, 6, 7, 8, 9, 11, 12, 13 and 15-17 are determined to be patentable as amended.

New claims 18-74 are added and determined to be patentable.

1. A stretchable apparatus, comprising:

an elastic member having first and second ends and configured to have a stretch of at least twice an original length;

a flexible sleeve member having first and second ends and disposed around the elastic member in a loose-fitting configuration, wherein the sleeve member is configured with an elasticity less than the elastic member to thereby provide a stretch limitation to the elastic member; and

first and second connectors secured to corresponding first and second ends of the elastic member, the first and second connectors further secured to corresponding first and second ends of the sleeve member; and

wherein the first end of the elastic member extends around at least a portion of the first connector, and wherein the elastic member comprises an aperture proximate the first end, the elastic member being configured to thread through the aperture to thereby connect the elastic member to the first connector.

5. [The] A stretchable apparatus [of claim 1], comprising: an elastic member having first and second ends and configured to have a stretch of at least twice an original length;

a flexible sleeve member having first and second ends and disposed around the elastic member in a loose-fitting configuration, wherein the sleeve member is configured with an elasticity less than the elastic member to thereby provide a stretch limitation to the elastic member; and

first and second connectors secured to corresponding first and second ends of the elastic member, the first and second connectors further secured to corresponding first and second ends of the sleeve member; and

wherein the sleeve member comprises a spiral member disposed substantially along the longitudinal length of the sleeve member.

6. [The] A stretchable apparatus [of claim 1], comprising: an elastic member having first and second ends and configured to have a stretch of at least twice an original length;

a flexible sleeve member having first and second ends and disposed around the elastic member in a loose-fitting

2

configuration, wherein the sleeve member is configured with an elasticity less than the elastic member to thereby provide a stretch limitation to the elastic member; and

first and second connectors secured to corresponding first and second ends of the elastic member, the first and second connectors further secured to corresponding first and second ends of the sleeve member; and

wherein the first connector comprises a base having an aperture through which the elastic member passes, wherein the first end of the elastic member is configured into a knot having a cross-section larger than the aperture to thereby prevent passage of the knot through the aperture.

7. [The] A stretchable apparatus [of claim 1], comprising: an elastic member having first and second ends and configured to have a stretch of at least twice an original length;

a flexible sleeve member having first and second ends and disposed around the elastic member in a loose-fitting configuration, wherein the sleeve member is configured with an elasticity less than the elastic member to thereby provide a stretch limitation to the elastic member; and

first and second connectors secured to corresponding first and second ends of the elastic member, the first and second connectors further secured to corresponding first and second ends of the sleeve member; and

wherein the first connector comprises: a base having an aperture through which the elastic member passes; and

a collar disposed around the elastic member and having a diameter larger than the aperture to thereby prevent passage of the collar through the aperture.

8. [The] A stretchable apparatus [of claim 1], comprising: an elastic member having first and second ends and configured to have a stretch of at least twice an original length;

a flexible sleeve member having first and second ends and disposed around the elastic member in a loose-fitting configuration, wherein the sleeve member is configured with an elasticity less than the elastic member to thereby provide a stretch limitation to the elastic member; and

first and second connectors secured to corresponding first and second ends of the elastic member, the first and second connectors further secured to corresponding first and second ends of the sleeve member; and

wherein the first connector comprises: a rigid object disposed within the elastic member proximate to the first end of the elastic member, wherein the rigid object has a diameter greater than an internal diameter of the elastic member; and

an end member having an aperture through which the elastic member passes, wherein the diameter of the elastic member at the location of the rigid object is greater than the aperture to thereby prevent passage of the rigid object through the aperture.

9. [The] A stretchable apparatus [of claim 1], comprising: an elastic member having first and second ends and configured to have a stretch of at least twice an original length;

a flexible sleeve member having first and second ends and disposed around the elastic member in a loose-fitting

US 6,202,263 C1

3

configuration, wherein the sleeve member is configured with an elasticity less than the elastic member to thereby provide a stretch limitation to the elastic member; and

first and second connectors secured to corresponding first and second ends of the elastic member, the first and second connectors further secured to corresponding first and second ends of the sleeve member; and

wherein the first connector comprises:

a base member at least partially disposed within the elastic member proximate to the first end of the elastic member, wherein the base member has a diameter greater than an internal diameter of the elastic member; and

an attachment member connected to the base member.

11. [The] A stretchable apparatus [of claim 1], comprising:

an elastic member having first and second ends and configured to have a stretch of at least twice an original length;

a flexible sleeve member having first and second ends and disposed around the elastic member in a loose-fitting configuration, wherein the sleeve member is configured with an elasticity less than the elastic member to thereby provide a stretch limitation to the elastic member; and

first and second connectors secured to corresponding first and second ends of the elastic member, the first and second connectors further secured to corresponding first and second ends of the sleeve member; and

wherein the first connector comprises an attachment member, wherein the first end of the elastic member extends around a portion of the attachment member, and wherein the elastic member is configured with an aperture proximate to the first end, the elastic member further configured to thread through the aperture to thereby secure the connection of the elastic member to the attachment member.

12. [The] A stretchable apparatus [of claim 1], comprising:

an elastic member having first and second ends and configured to have a stretch of at least twice an original length;

a flexible sleeve member having first and second ends and disposed around the elastic member in a loose-fitting configuration, wherein the sleeve member is configured with an elasticity less than the elastic member to thereby provide a stretch limitation to the elastic member; and

first and second connectors secured to corresponding first and second ends of the elastic member, the first and second connectors further secured to corresponding first and second ends of the sleeve member; and

wherein the first connector comprises:

a base member at least partially disposed within the elastic member proximate to the first end of the elastic member, wherein the base member has a diameter greater than an internal diameter of the elastic member;

a first attachment member connected to the base member;

a strap having first and second ends, wherein the first end of the strap is secured to the first attachment member; and

a second attachment member is secured to the second end of the strap.

4

13. A method for producing a stretchable apparatus, comprising:

providing an elastic member having first and second ends and configured to have a stretch of at least twice an original length;

disposing a loose-fitting, flexible sleeve member having first and second ends around the elastic member, wherein the sleeve member has an elasticity less than the elastic member to thereby provide a stretch limitation;

securing first and second connectors to the respective first and second ends of the elastic member; and

securing the first and second ends of the sleeve member to the first and second connectors; and

wherein securing the first end of the elastic member to the first connector comprises selecting a first connector having an opening formed therein, passing the first end of the elastic member through the opening, and disposing an object within the elastic member proximate the first end of the elastic member to thereby prevent the passage of the object through the opening.

15. [The] A method [of claim 13] for producing a stretchable apparatus, comprising:

providing an elastic member having first and second ends and configured to have a stretch of at least twice an original length;

disposing a loose-fitting, flexible sleeve member having first and second ends around the elastic member, wherein the sleeve member has an elasticity less than the elastic member to thereby provide a stretch limitation;

securing first and second connectors to the respective first and second ends of the elastic member; and

securing the first and second ends of the sleeve member to the first and second connectors; and

wherein the step of securing the first and second connectors comprises inserting a portion of the first and second connectors into the interior of the elastic member.

16. A stretchable apparatus, comprising:

an elastic member having first and second ends and configured to have a stretch of at least twice an original length;

a flexible sleeve member having first and second ends and disposed around the elastic member in a loose-fitting configuration, wherein the sleeve member is configured with an elasticity less than the elastic member to thereby provide a stretch limitation to the elastic member, the first and second ends of the sleeve member secured to the elastic member proximate to the corresponding first and second ends of the elastic member; and

first and second connectors secured to corresponding first and second ends of the elastic member; and

wherein the first connector is selected from the group consisting of:

a connector comprising a base having an opening through which the elastic member passes, and wherein the first end of the elastic member is configured into a knot having a cross section larger than the opening to thereby prevent passage of the knot through the opening;

a connector having an opening through which the first end of the elastic member passes, and having a collar disposed around the elastic member proximate to the opening.

US 6,202,263 C1

5

mate the first end to thereby prevent passage of the collar through the opening;

a connector having an opening through which the elastic member passes, and further comprising an object disposed within the elastic member proximate the first end of the elastic member to thereby prevent passage of the object through the opening;

a connector having a base portion at least partially disposed within the elastic member proximate to the first end of the elastic member, wherein the base portion has a diameter greater than the internal diameter of the first end of the elastic member, and wherein the connector further comprises an attachment portion connected to the base portion; and

a connector, wherein the elastic member has an opening formed proximate the first end of the elastic member, and wherein the first end of the elastic member is disposed at least partially around the connector, and wherein the second end of the elastic member is passed through the opening to thereby secure the elastic member to the connector.

17. A method for producing a stretchable apparatus, comprising:

providing an elastic member having first and second ends and configured to have a stretch of at least twice an original length;

disposing a loose-fitting, flexible sleeve member having first and second ends around the elastic member, wherein the sleeve member has an elasticity less than the elastic member to thereby provide a stretch limitation;

securing the first and second ends of the sleeve member to the elastic member proximate to the corresponding first and second ends of the elastic member; and

securing first and second connectors to the respective first and second ends of the elastic member; and

wherein the securing the first connector to the first end of the elastic member comprises selecting a first connector from the group consisting of:

a connector comprising a base having an opening through which the elastic member passes, and wherein the first end of the elastic member is configured into a knot having a cross section larger than the opening to thereby prevent passage of the knot through the opening;

a connector having an opening through which the first end of the elastic member passes, and having a collar disposed around the elastic member proximate the first end to thereby prevent passage of the collar through the opening;

a connector having an opening through which the elastic member passes, and further comprising an object disposed within the elastic member proximate the first end of the elastic member to thereby prevent passage of the object through the opening;

a connector having a base portion at least partially disposed within the elastic member proximate to the first end of the elastic member, wherein the base portion has a diameter greater than the internal diameter of the first end of the elastic member, and wherein the connector further comprises an attachment portion connected to the base portion; and

a connector, wherein the elastic member has an opening formed proximate the first end of the elastic member, and wherein the first end of the elastic member is disposed at least partially around the

6

connector, and wherein the second end of the elastic member is passed through the opening to thereby secure the elastic member to the connector.

18. The apparatus of claim 6, wherein the first connector comprises a strap.

19. The apparatus of claim 18, wherein the strap is connected so as to form a loop.

20. The apparatus of claim 6, wherein the flexible sleeve member passes through the aperture.

21. The apparatus of claim 6, further comprising an attachment mechanism configured for releasable attachment to a second object.

22. The apparatus of claim 21, wherein the attachment mechanism is part of the first connector.

23. The apparatus of claim 18, wherein the strap further comprises a grommet or eyelet placed in the aperture.

24. The apparatus of claim 6, wherein the first connector comprises a connecting portion attached to the base.

25. The apparatus of claim 24, wherein the connecting portion has a shape selected from the group consisting of a loop, a circle, and oval, a hook, and a polygon.

26. The apparatus of claim 6, further comprising a strap attached to the first connector.

27. The apparatus of claim 6, further comprising a second connector attached to the first connector.

28. The apparatus of claim 7, wherein the first connector comprises a strap.

29. The apparatus of claim 28, wherein the strap is connected so as to form a loop.

30. The apparatus of claim 7, wherein the first connector further comprises an eyelet or grommet placed in the aperture.

31. The apparatus of claim 7, further comprising an attachment mechanism configured for releasable attachment to a second object.

32. The apparatus of claim 7, wherein the flexible sleeve member passes through the aperture.

33. The apparatus of claim 7, wherein the first connector further comprises a connecting portion attached to the base.

34. The apparatus of claim 7, further comprising a strap attached to the first connector.

35. The apparatus of claim 7, further comprising a second connector attached to the first connector.

36. The apparatus of claim 8, wherein the rigid object is spherical.

37. The apparatus of claim 8, wherein the rigid object has a generally circular cross section.

38. The apparatus of claim 8, wherein the first connector comprises a strap.

39. The apparatus of claim 38, wherein the strap is connected so as to form a loop.

40. The apparatus of claim 8, wherein the flexible sleeve passes through the aperture.

41. The apparatus of claim 8, further comprising an attachment mechanism configured for releasable attachment to a second object.

42. The apparatus of claim 38, wherein the flexible sleeve is attached to the strap.

43. The apparatus of claim 8, wherein the first connector comprises a base portion and a connecting portion, and wherein the aperture is formed in the base portion.

44. The apparatus of claim 43, wherein the connecting portion has a shape selected from the group consisting of a hook, a loop, a circle, an oval, and a polygon.

45. The apparatus of claim 8, further comprising a strap attached to the first connector.

46. The apparatus of claim 8, further comprising a second connector attached to the first connector.

US 6,202,263 C1

7

47. The apparatus of claim 46, wherein the second connector is attached to the first connector via a strap.

48. The apparatus of claim 9, further comprising an attachment mechanism configured for releasable attachment to a second object.

49. The apparatus of claim 9, wherein the base member has a circular cross section.

50. The apparatus of claim 9, wherein the base member is elongate.

51. The apparatus of claim 9, wherein the attachment member has a shape selected from the group consisting of a hook, a loop, a circle, an oval, and a polygon.

52. The apparatus of claim 9, wherein the base member is cylindrical.

53. The apparatus of claim 1, wherein the first connector comprises a strap.

54. The apparatus of claim 53, wherein the strap is connected into a loop.

55. The apparatus of claim 1, wherein the first connector has a shape selected from the group consisting of a hook, a loop, a circle, an oval, and a polygon.

56. The apparatus of claim 1, further comprising a strap attached to the first connector.

57. The apparatus of claim 1, further comprising a second connector attached to the first connector.

58. The apparatus of claim 1, further comprising an attachment mechanism configured for releasable attachment to a second object.

59. The apparatus of claim 11, wherein the attachment member is a portion of the first connector configured for receiving the elastic member.

60. The apparatus of claim 11, wherein the first connector comprises a strap.

61. The apparatus of claim 11, wherein the first connector has a shape selected from the group consisting of a hook, a loop, a circle, an oval and a polygon.

62. The apparatus of claim 11, further comprising a strap attached to the connector.

63. The apparatus of claim 11, further comprising a second connector attached to the first connector.

64. The apparatus of claim 11, further comprising an attachment mechanism configured for releasable attachment to a second object.

65. The apparatus of claim 12, wherein the flexible sleeve is attached to the strap.

8

66. The method of claim 13, wherein the method further comprises passing the flexible sleeve through the opening.

67. The method of claim 13, wherein the first connector comprises a strap.

68. The method of claim 13, wherein the opening in the first connector further comprises an eyelet or grommet.

69. The method of claim 67, wherein the strap is connected into a loop.

70. The method of claim 13, wherein the elastic member at the location of the object is larger in diameter than the opening.

71. The method of claim 13, wherein the first connector comprises a base portion having the opening formed therein and a connector portion attached to the base portion.

72. A method for producing a stretchable apparatus, comprising:

providing an elastic member having first and second ends and configured to have a stretch of at least twice an original length;

disposing a loose-fitting, flexible sleeve member having first and second ends around the elastic member, wherein the sleeve member has an elasticity less than the elastic member to thereby provide a stretch limitation;

securing first and second connectors to the respective first and second ends of the elastic member; and

securing the first and second ends of the sleeve member to the first and second connectors; and

wherein securing the first end of the elastic member to the first connector comprises selecting an elastic member having an opening formed proximate the first end, disposing the first end of the elastic member around at least a portion of the first connector, and passing the second end of the elastic member through the opening to thereby secure the elastic member to the first connector.

73. The method of claim 72, wherein the first connector comprises a strap.

74. The method of claim 72, wherein the method further comprises attaching a strap to the first connector.

* * * * *

EXHIBIT C

Greater Performance Inc.

Simply the best in SPEED Training Equipment

Contents

- Home Page
- About Us
- Contact Us
- Testimonies
- Used By
- Catalog
- Links

As Seen On

- TV & ESPN

GPI-USA Football



There are many sports out there,
you can benefit from the
SPEEDSTER in any of them.

- Football
- Hockey
- Basketball
- Baseball
- Track
- Soccer
- Volleyball
- Softball

The Speedster Training System is the number one tool used by Rich Gannon to enhance his speed and quickness, not to mention his endurance. Like Rich, you can move to a higher level in sports by training with Speedster. The best in football athletic equipment!



Extra's

**Leave a Testimony
 Feedback - Comments**

Any sport that needs SPEED and Quickness, needs the SPEEDSTER Training System!

**Proudly made in the heart
 of America!
 Kansas City, MO**



Speedster Training System	Chaser	Quick Foot Ladder
Explosive Quickness	Tough Tow Resister	quick feet
Lightning Speed	Power Runner	Sky Leaper
Speedster II	Shadow Belt	Power Kicker
Jump to where you want to go!		

Speedster Training System tm

The SPEEDSTER Training System is a 3 phase complete speed and quickness training program.

**HEAVY RESISTANCE, LIGHT RESISTANCE,
 AND OVER-SPEED TRAINING**

**ONLY
 \$199.95**

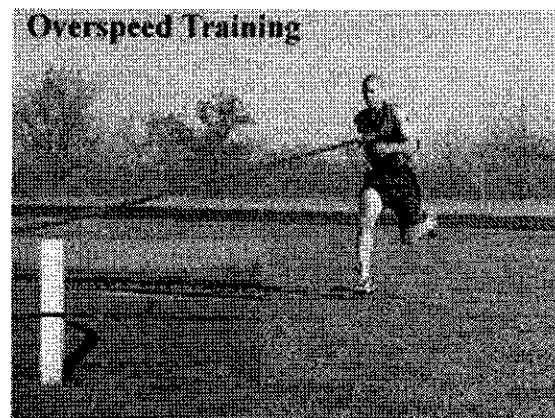
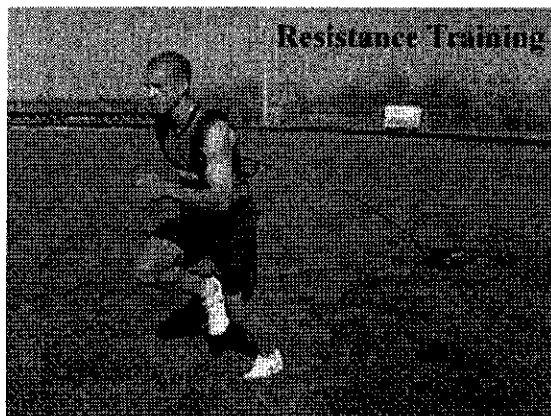

Heavy resistance develops super explosive starts while light resistance increases acceleration speed. Over/Speed develops faster sprint speed by developing the function of the fast twitch muscle fiber. Over/Speed training will increase a longer stride length as well as increasing leg turn over rate.

Lightning Cord for over/speed training which pulls the runner (faster than their natural sprint speed) up to a total of 40 yards of sprint speed.



Training Video	4 Week Training Program	Instruction Manual
-----------------------	--------------------------------	---------------------------

A 15 min Video with Roberto Parker.

How to use the SPEEDSTER plus several other drills that can be done with the equipment.

Includes:

- The SPEEDSTER Training Harness
- Torpedo Sprint Sled
- Weight Resistance Bags
- 30' Safety Covered Lightning Cord
- Instructional Manual
- 4 Week Training Program
- The SPEEDSTER Video

1500	Complete SPEEDSTER Training System	\$199.95	Qty: 0	 Add to Your SHOPPING CART
------	------------------------------------	----------	--------	----------------------------------------------------------------------------------------------------------------------

Greater Performance Inc.

1-800-538-7786

EXPLOSIVE POWER

Speedster Training Harness

Run a Faster 40 Yard Dash!!

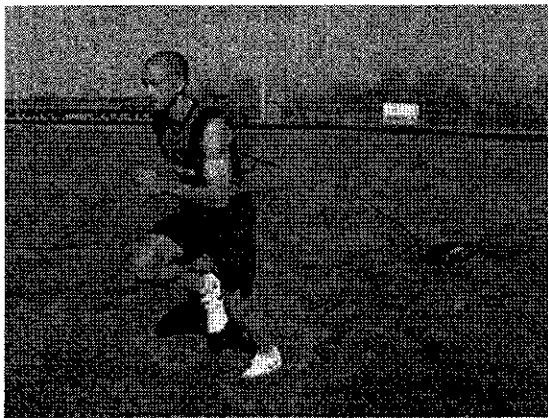

Develops:



- First Step Explosive Power
- Quickness
- Endurance
- Proper Running Form

Includes:

- 1 - Adjustable SPEEDSTER Harness
- 1 - Torpedo Sled
- 1 - Set of Towlines
- 4 - Resistance Weight Bags
- 1 - Manual
- 1 - 4 Week Training Program

Resistance Training

The SPEEDSTER Training Harness is the ultimate training product to develop explosive power and quickness. The resistance training is done by attaching the Torpedo Sprint Sled to your SPEEDSTER Harness. Then add up to 60 pounds to your sled by placing the weight resistance bags filled with sand in your sled. The more weight the more resistance.

1000	SPEEDSTER Training Harness - was \$80.95 now	\$50.95	Qty: 0	 Add to Your SHOPPING CART
1100	SPEEDSTER Harness, Sled, Towlines	\$130.95	Qty: 0	 Add to Your SHOPPING CART

Lightning OVER-SPEED Training

SPEEDSTER Lightning Cord tm

DEVELOPS:

- Lightning SPEED
- Quickness
- Longer Stride
- Faster Leg Repetition
- Faster TOP Speed

Attaches to SPEEDSTER Training Harness



OVER-SPEED Training

Reverse the SPEEDSTER Training Harness and simply attach your Lighting Cord. You are now ready to develop a faster leg repetition and a longer stride. The use of the Lightning Cord trains the muscles to move at a greater rate of motion. Each time this training is repeated, your muscles remember the faster movements, which create a natural faster leg movement and a longer stride.

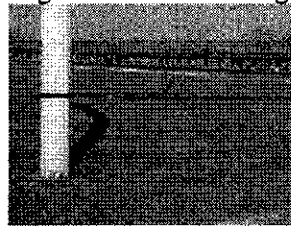

Attaches to a stationary object.

The 30' Lightning Cord allows up to 40 yds of OVER-SPEED Training!

Lightning Cord Size Chart
Up to 125 pounds - Regular
Over 125 pounds - Heavy

Replacement Cords

2000	30' Regular Lightning Cord with Cover	\$85.95	Qty: 0 <input type="text"/>	Add to Your SHOPPING CART
3000	30' Heavy Lightning Cord with Cover	\$90.95	Qty: 0 <input type="text"/>	Add to Your SHOPPING CART
7200	SPEEDSTER Waist Belt with 30' Regular Cord	\$104.95	Qty: 0 <input type="text"/>	Add to Your SHOPPING CART
7220	SPEEDSTER Harness with 30' Regular Cord	\$155.95	Qty: 0 <input type="text"/>	Add to Your SHOPPING CART
7300	SPEEDSTER Waist Belt with 30' Heavy Cord	\$110.95	Qty: 0 <input type="text"/>	Add to Your SHOPPING CART
7330	SPEEDSTER Harness with 30' Heavy Cord	\$160.95	Qty: 0 <input type="text"/>	Add to Your SHOPPING CART

There's not a better Cord on the market!

SPEEDSTER II tm

For the Player who needs superior lateral movement and quick reaction to **MAKE THE PLAY!**

Develops:

- Lateral Speed & Quickness
- Change of Direction
- Stop and Start Quickness
- Explosive First Step





Great for change of direction drills!

Includes:

- 1 - Adjustable SPEEDSTER Waist Belt
- 1 - 10' Lightning Cord with Safety Cover
- 1 - Anchor Strap
- 1 - Instruction Manual & Workout Program



Resistance - Assistance Sandwich Drill

5000	SPEEDSTER II with Heavy Cord	\$65.95	Qty: 0	 Add to Your SHOPPING CART
5010	SPEEDSTER II with Regular Cord	\$62.95	Qty: 0	 Add to Your SHOPPING CART

Lightning Cord Size Chart

Up to 125 pounds - Regular

Over 125 Pounds - Heavy

The SPEED Chaser tm

Great Sprint Workout!

Picture Coming Soon



Develops:

- Acceleration!!

Two players work together. The lead player sprints stretching the Lightning Cord creating resistance. As the lead player gets about 15yds ahead, the trail player goes from a slow jog to a full sprint toward the lead player. The stretched cord pulls the trail player faster than their normal run. The over speed training increases stride length and a faster rate of motion. The 15' Lightning Cord with cover stretches up to 60'.

Includes:

- 2 - Adjustable SPEEDSTER Waist Belts
- 1 - 15' Lightning Cord with Safety Cover

6000	SPEED Chaser with Heavy Cord	\$85.95	Qty: 0	 Add to Your SHOPPING CART
6010	SPEED Chaser with Regular Cord	\$80.95	Qty: 0	 Add to Your SHOPPING CART

Tough Tow Resister™



Develops:

- **Powerful Sprint Strength**

Picture Coming Soon

The Tough Tow Resister attaches to either the SPEEDSTER Training Harness or the SPEEDSTER Waist Belt. The player sprints full speed as their partner creates resistance, developing a powerful sprint stride.

Easy to hold handle

4000	Tough Tow Resister with SPEEDSTER waist Belt	\$35.95	Qty: 0	 Add to Your SHOPPING CART
4015	Tough Tow Resister only with Handle	\$15.95	Qty: 0	 Add to Your SHOPPING CART

Power Runner™

Develops:

- **High Powerful Knee Action**
- **Promotes Balance**

GREAT HIP WORKOUT!!

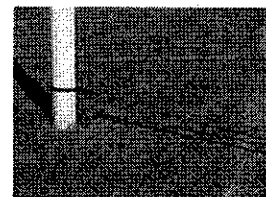
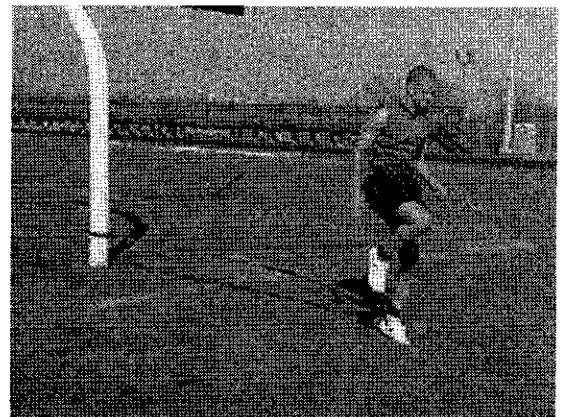
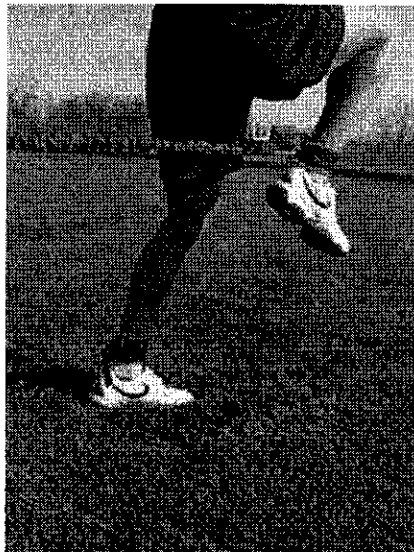

Includes:

The Power Runner develops high knee action and promotes balance. As the player runs away from the anchor point the Lightning Cord tightens forcing the player to exert more strength to keep the Lightning Cord stretched.

- 2 - Padded Adjustable Ankle Cuffs with Quick Release Snaps
- 2 - 5' Lightning Cords
- 1 - Anchor Strap
- Instruction Manual

7500	Power Runner	\$65.95	Qty: 0	 Add to Your SHOPPING CART
------	--------------	---------	--------	----------------------------------------------------------------------------------------------------------------------

Shadow Belt™

Develops:

- **Lightning Quick Reaction**

**DON'T LET YOUR OPPONENT JUKE YOU,
 LEAVING YOU GRABBING FOR THIN AIR!**

Picture Coming Soon!

Includes:

- 2 - Adjustable Nylon Belts with Velcro Ends

Two players wear adjustable waist belts connected in the middle by a Velcro strip. One player initiates the movement and the other player has to shadow each movement not allowing the nylon strap to tighten. When the 2 straps become detached the drill is over.

7000	Shadow Belt	\$15.95	Qty: 0	 Add to Your SHOPPING CART
------	-------------	---------	--------	------------------------------------------------------------------------------------------------------------------------

Quick Foot Ladder™

Develops:

- **Quick Foot Action**
- **Agility**
- **Coordination**

The Quick Foot Ladder lies flat on the ground. It can be used as a single 10 yd long ladder or double for 2 - 5 yd ladders for shorter more explosive drills. Fixed slats guarantee you will always have the proper spacing.

Includes:

- 1 - Quick Foot Ladder

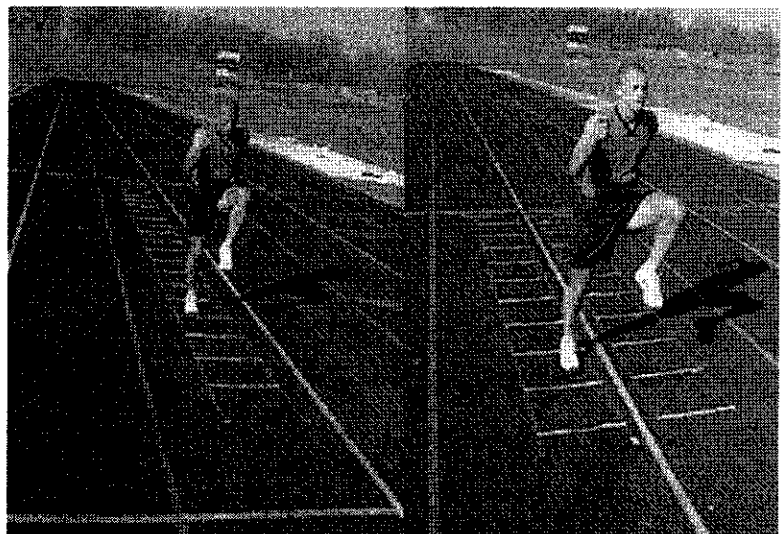

Single

Double

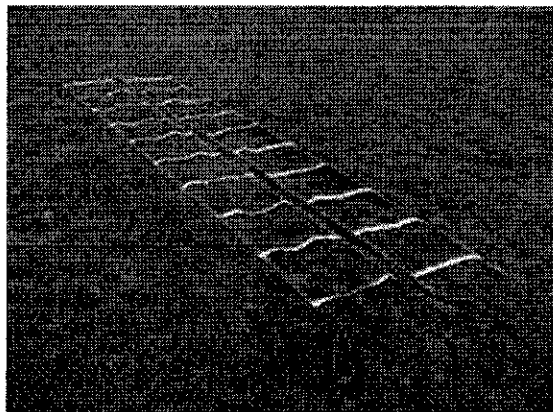

Can be used on a track or grassy area!

8100	Quick Foot Ladder	\$59.95	Qty: 0	 Add to Your SHOPPING CART
------	-------------------	---------	--------	----------------------------------------------------------------------------------------------------------------------

Quick Feet tm

Develops:

- Lateral Speed
- Agility
- Coordination
- Balance

Great for Linemen. The Guys who get it done!

The Ankle cuffs are connected by a small Lightning Cord. When you step a direction the cord stretches forcing the trail foot to follow.

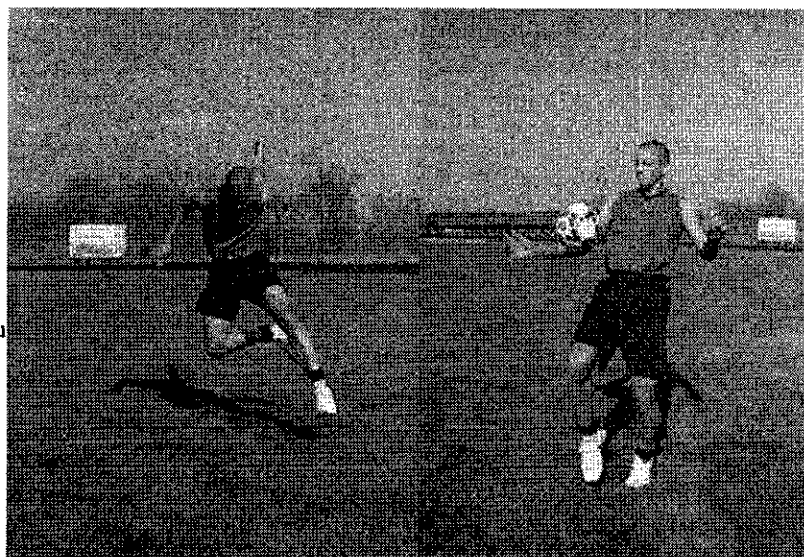

Includes:

- 2 - Adjustable Ankle Cuffs with Lightning Cord

Using Quick Feet helps strengthen the groin area. Used during pass blocking drills, Quick Feet allows the player to keep a proper base, by allowing them to feel the resistance. It is great for lateral walks, shuffles, and slides.

8000	Quick Feet	\$35.95	Qty: 0	 Add to Your SHOPPING CART
------	------------	---------	--------	------------------------------------------------------------------------------------------------------------------------

Sky Leaper tm

Develops:

- Explosive Jumping Thrust!

Includes:

- 1 - Adjustable SPEEDSTER Waist Belt

- 2 - Sky Leaper Cords with Safety Covers

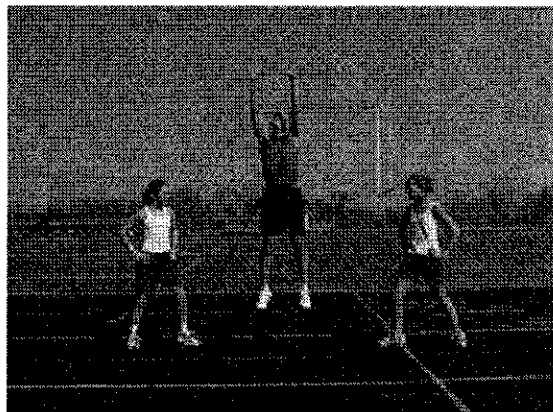

Trains the lower body to develop explosiveness and strength, which creates a higher vertical jump and faster explosion off the ground. By doing repeated quick jumps the muscles are trained to react the same way in a game situation.

9200	Sky Leaper with Regular Cords	\$45.95	Qty: 0	Add to Your SHOPPING CART
9220	Extra Regular Cord for Sky Leaper	\$12.95	Qty: 0	Add to Your SHOPPING CART
9300	Sky Leaper with Heavy Cords	\$50.95	Qty: 0	Add to Your SHOPPING CART
9330	Extra Heavy Cord for Sky Leaper	\$15.95	Qty: 0	Add to Your SHOPPING CART

Power Kicker™



Develops:

- Super Kicking Power

Includes:

- 1 - Adjustable Ankle Cuff
- 1 - 5' Resistance Cord
- 1 - Connecting Strap



Add Distance to your Kicks!

9700	Power Kicker with Regular Cord	\$34.95	Qty: 0	Add to Your SHOPPING CART
9730	Power Kicker with Heavy Cord	\$36.95	Qty: 0	Add to Your SHOPPING CART

Additional Equipment				
1000	SPEEDSTER Training Harness	\$80.95	Qty: 0	 Add to Your SHOPPING CART
1040	SPEEDSTER Waist Belts - Pair	\$40.95	Qty: 0	 Add to Your SHOPPING CART
1045	SPEEDSTER Waist Belt - Single	\$22.95	Qty: 0	 Add to Your SHOPPING CART
2000	30' Regular Lightning Cord with Cover	\$85.95	Qty: 0	 Add to Your SHOPPING CART
2010	15' Regular Lightning Cord with Cover	\$59.95	Qty: 0	 Add to Your SHOPPING CART
2020	10' Regular Lightning Cord with Cover	\$42.95	Qty: 0	 Add to Your SHOPPING CART
3000	30' Heavy Lightning Cord with Cover	\$90.95	Qty: 0	 Add to Your SHOPPING CART
3010	15' Heavy Lightning Cord with Cover	\$65.95	Qty: 0	 Add to Your SHOPPING CART
3020	10' Heavy Lightning Cord with Cover	\$45.95	Qty: 0	 Add to Your SHOPPING CART
4510	Tough Tow Resister (Leash)	\$6.95	Qty: 0	 Add to Your SHOPPING CART

Note: The optional safety cover helps protect the lightning cord and prevents the cord from being over stretched.

MAXIMUM CORD STRETCH

30' Cord - 120' or 40 yards

15' Cord - 60'

10' Cord - 40'

There is not a better Cord on the market!

THICKER CORD - LONGER STRETCH



[Home](#) | [About Us](#) | [Pick Your Sport](#) | [Contact Us](#) | [Catalog](#)

[ESPN](#) | [Testimony](#) | [Feedback](#)

CIVIL COVER SHEET

JS 44 (Rev. 11/04)

The JS 44 civil cover sheet and the information contained herein neither replace nor supplement the filing and service of pleadings or other papers as required by law, except as provided by local rules of court. This form, approved by the Judicial Conference of the United States in September 1974, is required for the use of the Clerk of Court for the purpose of initiating the civil docket sheet. (SEE INSTRUCTIONS ON THE REVERSE OF THE FORM.)

I. (a) PLAINTIFFS
 Hark'n Technologies, Ltd.,
 a North Carolina corporation

(b) County of Residence of First Listed Plaintiff Davis County, Utah
 (EXCEPT IN U.S. PLAINTIFF CASES)

(c) Attorney's (Firm Name, Address, and Telephone Number)
 Perry S. Clegg, Bateman IP Law Group, 8 E. Broadway, Suite 550, P.O.
 Box 1319, Salt Lake City, UT 84110; (801) 533-0320

DEFENDANTS
 Greater Performance, Inc.,
 a Missouri corporation

County of Residence of First Listed Defendant Clinton County, MO
 (IN U.S. PLAINTIFF CASES ONLY)

NOTE: IN LAND CONDEMNATION CASES, USE THE LOCATION OF THE LAND INVOLVED.

Attorneys (If Known)

FILED
 U.S. DISTRICT COURT
 Clinton County, MO
 7/7/06
 DISTRICT OF UTAH
 BY: _____
 DEPUTY CLERK

II. BASIS OF JURISDICTION (Place an "X" in One Box Only)

1 U.S. Government Plaintiff

3 Federal Question (U.S. Government Not a Party)

2 U.S. Government Defendant

4 Diversity (Indicate Citizenship of Parties in Item III)

III. CITIZENSHIP OF PRINCIPAL PARTIES (Place an "X" in One Box for Plaintiff and One Box for Defendant)

Citizen of This State	PTF <input checked="" type="checkbox"/> 1	DEF <input type="checkbox"/> 1	Incorporated or Principal Place of Business In This State	PTF <input checked="" type="checkbox"/> 4	DEF <input type="checkbox"/> 4
Citizen of Another State	<input type="checkbox"/> 2	<input checked="" type="checkbox"/> 2	Incorporated and Principal Place of Business In Another State	<input type="checkbox"/> 5	<input checked="" type="checkbox"/> 5
Citizen or Subject of a Foreign Country	<input type="checkbox"/> 3	<input type="checkbox"/> 3	Foreign Nation	<input type="checkbox"/> 6	<input type="checkbox"/> 6

IV. NATURE OF SUIT (Place an "X" in One Box Only)

CONTRACT	TORTS	FORFEITURE/PENALTY	BANKRUPTCY	OTHER STATUTES	
<input type="checkbox"/> 110 Insurance <input type="checkbox"/> 120 Marine <input type="checkbox"/> 130 Miller Act <input type="checkbox"/> 140 Negotiable Instrument <input type="checkbox"/> 150 Recovery of Overpayment & Enforcement of Judgment <input type="checkbox"/> 151 Medicare Act <input type="checkbox"/> 152 Recovery of Defaulted Student Loans (Excl. Veterans) <input type="checkbox"/> 153 Recovery of Overpayment of Veteran's Benefits <input type="checkbox"/> 160 Stockholders' Suits <input type="checkbox"/> 190 Other Contract <input type="checkbox"/> 195 Contract Product Liability <input type="checkbox"/> 196 Franchise	PERSONAL INJURY <input type="checkbox"/> 310 Airplane <input type="checkbox"/> 315 Airplane Product Liability <input type="checkbox"/> 320 Assault, Libel & Slander <input type="checkbox"/> 330 Federal Employers' Liability <input type="checkbox"/> 340 Marine <input type="checkbox"/> 345 Marine Product Liability <input type="checkbox"/> 350 Motor Vehicle <input type="checkbox"/> 355 Motor Vehicle Product Liability <input type="checkbox"/> 360 Other Personal Injury	PERSONAL INJURY <input type="checkbox"/> 362 Personal Injury - Med. Malpractice <input type="checkbox"/> 365 Personal Injury - Product Liability <input type="checkbox"/> 368 Asbestos Personal Injury Product Liability PERSONAL PROPERTY <input type="checkbox"/> 370 Other Fraud <input type="checkbox"/> 371 Truth in Lending <input type="checkbox"/> 380 Other Personal Property Damage <input type="checkbox"/> 385 Property Damage Product Liability	<input type="checkbox"/> 610 Agriculture <input type="checkbox"/> 620 Other Food & Drug <input type="checkbox"/> 625 Drug Related Seizure of Property 21 USC 881 <input type="checkbox"/> 630 Liquor Laws <input type="checkbox"/> 640 R.R. & Truck <input type="checkbox"/> 650 Airline Regs. <input type="checkbox"/> 660 Occupational Safety/Health <input type="checkbox"/> 690 Other	<input type="checkbox"/> 422 Appeal 28 USC 158 <input type="checkbox"/> 423 Withdrawal 28 USC 157 PROPERTY RIGHTS <input type="checkbox"/> 820 Copyrights <input checked="" type="checkbox"/> 830 Patent <input type="checkbox"/> 840 Trademark	<input type="checkbox"/> 400 State Reapportionment <input type="checkbox"/> 410 Antitrust <input type="checkbox"/> 430 Banks and Banking <input type="checkbox"/> 450 Commerce <input type="checkbox"/> 460 Deportation <input type="checkbox"/> 470 Racketeer Influenced and Corrupt Organizations <input type="checkbox"/> 480 Consumer Credit <input type="checkbox"/> 490 Cable/Sat TV <input type="checkbox"/> 810 Selective Service <input type="checkbox"/> 850 Securities/Commodities/Exchange <input type="checkbox"/> 875 Customer Challenge 12 USC 3410 <input type="checkbox"/> 890 Other Statutory Actions <input type="checkbox"/> 891 Agricultural Acts <input type="checkbox"/> 892 Economic Stabilization Act <input type="checkbox"/> 893 Environmental Matters <input type="checkbox"/> 894 Energy Allocation Act <input type="checkbox"/> 895 Freedom of Information Act <input type="checkbox"/> 900 Appeal of Fee Determination Under Equal Access to Justice <input type="checkbox"/> 950 Constitutionality of State Statutes
REAL PROPERTY <input type="checkbox"/> 210 Land Condemnation <input type="checkbox"/> 220 Foreclosure <input type="checkbox"/> 230 Rent Lease & Ejectment <input type="checkbox"/> 240 Torts to Land <input type="checkbox"/> 245 Tort Product Liability <input type="checkbox"/> 290 All Other Real Property	CIVIL RIGHTS <input type="checkbox"/> 441 Voting <input type="checkbox"/> 442 Employment <input type="checkbox"/> 443 Housing/Accommodations <input type="checkbox"/> 444 Welfare <input type="checkbox"/> 445 Amer. w/Disabilities - Employment <input type="checkbox"/> 446 Amer. w/Disabilities - Other <input type="checkbox"/> 440 Other Civil Rights	PRISONER PETITIONS <input type="checkbox"/> 510 Motions to Vacate Sentence Habeas Corpus: <input type="checkbox"/> 530 General <input type="checkbox"/> 535 Death Penalty <input type="checkbox"/> 540 Mandamus & Other <input type="checkbox"/> 550 Civil Rights <input type="checkbox"/> 555 Prison Condition	LABOR <input type="checkbox"/> 710 Fair Labor Standards Act <input type="checkbox"/> 720 Labor/Mgmt. Relations & Disclosure Act <input type="checkbox"/> 730 Labor/Mgmt. Reporting & Disclosure Act <input type="checkbox"/> 740 Railway Labor Act <input type="checkbox"/> 790 Other Labor Litigation <input type="checkbox"/> 791 Empl. Ret. Inc. Security Act	SOCIAL SECURITY <input type="checkbox"/> 861 HIA (1395ff) <input type="checkbox"/> 862 Black Lung (923) <input type="checkbox"/> 863 DIWC/DIWW (405(g)) <input type="checkbox"/> 864 SSID Title XVI <input type="checkbox"/> 865 RSI (405(g)) FEDERAL TAX SUITS <input type="checkbox"/> 870 Taxes (U.S. Plaintiff or Defendant) <input type="checkbox"/> 871 IRS—Third Party 26 USC 7609	

V. ORIGIN (Place an "X" in One Box Only)

1 Original Proceeding

2 Removed from State Court

3 Remanded from Appellate Court

4 Reinstated or Reopened

5 Transferred from another district (specify)

6 Multidistrict Litigation

7 Appeal to District Judge from Magistrate Judgment

VI. CAUSE OF ACTION

Cite the U.S. Civil Statute under which you are filing (Do not cite jurisdictional statutes unless diversity):
35 U.S.C. Sect. 271 (a) and Sect. 271 (b)

Brief description of cause:
Patent infringement

VII. REQUESTED IN COMPLAINT:

CHECK IF THIS IS A CLASS ACTION UNDER F.R.C.P. 23

DEMAND \$ _____

CHECK YES only if demanded in complaint:
 JURY DEMAND: Yes No

VIII. RELATED CASE(S) IF ANY (See instructions):

JUDGE Ortrie D. Smith

Western District of Missouri

DOCKET NUMBER 5:01-CV-06086-ODS

DATE 7/7/06

SIGNATURE OF ATTORNEY OF RECORD _____

FOR OFFICE USE ONLY

RECEIPT # _____ AMOUNT _____ APPLYING IFP _____

Judge Dale A. Kimball
 DECK TYPE: Civil
 DATE STAMP: 07/07/2006 @ 16:11:44
 CASE NUMBER: 1:06CV00077 DAK