

in Ohio, including, but not limited to, Cowan Systems, LLC, a truckload carrier who, upon information and belief, is actively recruiting additional employees in Ohio. In addition, Microdea acknowledges on its website that it is the “proud partner of TMW Systems and provides their customers with leading edge document and imaging solutions.” Upon information and belief, TMW Systems is a trucking software company that is incorporated and headquartered in Ohio, and Microdea’s partnership with TMW Systems includes substantial business activity within the state of Ohio.

4. Upon information and belief, this Court has specific personal jurisdiction over Microdea because it has caused and induced others to use its hardware device, IN CAB SCANNING, within the state of Ohio in a manner that infringes on a patent owned by R+L, causing R+L harm and tortious injury in this judicial district.

5. Venue is appropriate in this judicial district pursuant to 28 U.S.C. §§ 1391(d) and 1400(b).

The Parties

6. R+L is a corporation organized and existing under the laws of the State of Ohio, and has its principal place of business at 600 Gillam Road, Wilmington, Ohio 45177.

7. Upon information and belief, Microdea is a Canadian corporation with its headquarters at 15 Wertheim Court, Suite 301, Richmond Hill, Ontario L4B 3H7.

The Infringed Patent

8. The United States Patent and Trademark Office duly and legally issued United States Patent No. 6,401,078 B1 (“the ‘078 Patent”) entitled “Bill of Lading Transmission and Processing System for Less Than a Load Carriers” on June 4, 2002. A copy of the ‘078 Patent is attached as Exhibit A.

9. The '078 Patent claims a process directed to the transfer of shipping documentation for a package (freight) to a processing center. In particular, documentation for a package is scanned and transmitted wirelessly to a remote processing center. The processing center then prepares a loading manifest that includes the package, prior to the package being removed from the transporting vehicle.

10. R+L owns all right, title and interest in the '078 Patent via assignment.

Actions Giving Rise to this Complaint

11. Microdea offers fully integrated, technological solutions to the transportation industry.

12. Upon information and belief, Microdea markets and sells IN CAB SCANNING to its trucking customers. According to a recent press release found on its website, IN CAB SCANNING is a "rugged, small foot-print document scanner that can be mounted in the truck cab."

13. Upon information and belief, Microdea's IN CAB SCANNING integrates with transportation communication systems and software, such as PeopleNet's g3 mobile device, to perform a process that infringes on the '078 Patent.

14. According to Microdea's website, IN CAB SCANNING provides "immediate scanning of source documents such as Bills of Lading ("BOL's) at the point of transaction. Scanned documents are uploaded to the corporate office within minutes of signing and scanning to expedite the billing process."

15. In a press release found on its website, Microdea acknowledges that IN CAB SCANNING enables the company offices of its customers "to transmit cargo manifests, billing orders and other documents directly to drivers on the road."

16. Thus, upon information and belief, Microdea is contributing to and actively inducing the infringement of the '078 Patent by marketing and selling IN CAB SCANNING, and encouraging motor carriers to use IN CAB SCANNING to remotely transmit shipping documents from onboard a motor vehicle to a remote processing facility. There, a loading document is prepared that includes the further transport of goods on another vehicle. Microdea does so without leave or license of R+L, and in violation of R+L's rights.

COUNT I—CONTRIBUTORY INFRINGEMENT

17. R+L repeats and realleges the allegations contained in paragraphs 1-16 above as if fully set forth herein.

18. Upon information and belief, Microdea knowingly sells and offers to sell IN CAB SCANNING to customers who use it in conjunction with other applications and processes, and in a manner that infringes on the patented process claimed in the '078 Patent. Microdea's conduct amounts to contributory infringement in violation of 35 U.S.C. § 271(c).

19. Upon information and belief, Microdea has profited and will continue to profit from contributing to the infringement of the '078 Patent.

20. Microdea's actions with regard to contributing to the infringement of the '078 Patent has caused and will continue to cause R+L substantial and irreparable injury, for which R+L is entitled to receive injunctive relief and adequate compensatory damages.

21. Further, the actions of Microdea with regard to contributing to the infringement of the '078 Patent are willful such that R+L is entitled to treble damages under 35 U.S.C. § 284.

COUNT II—ACTIVE INDUCEMENT OF INFRINGEMENT

22. R+L repeats and realleges the allegations contained in paragraphs 1-21 above as if fully set forth herein.

23. Upon information and belief, Microdea knowingly encourages and intends for its customers to use IN CAB SCANNING in conjunction with other applications and processes, and in a manner that infringes on the patented process claimed in the '078 Patent. Microdea's conduct amounts to active inducement of infringement in violation of 35 U.S.C. § 271(b).

24. Upon information and belief, Microdea has profited and will continue to profit from actively inducing the infringement of the '078 Patent.

25. The actions of Microdea with regard to actively inducing the infringement of the '078 Patent has caused and will continue to cause R+L substantial and irreparable injury, for which R+L is entitled to receive injunctive relief and adequate compensatory damages.

26. Further, the actions of Microdea with regard to actively inducing the infringement of the '078 Patent are willful such that R+L is entitled to treble damages under 35 U.S.C. § 284.

Demand for Relief

WHEREFORE, R+L respectfully requests that this Court enter judgment as to both count as follows:

A. Declare that R+L is the owner of the '078 Patent and that the '078 Patent is valid and enforceable;

B. Preliminarily and permanently enjoin Microdea, its employees and agents, and any others acting in concert with Microdea, from contributing to and/or actively inducing the infringement of the '078 Patent;

C. Award R+L its damages resulting from Microdea's contribution to and active inducement of the infringement of the '078 Patent;

D. Award R+L treble damages pursuant to 35 U.S.C. § 284 as a result of Microdea's willfulness in contributing to and actively inducing the infringement of the '078 Patent;

- E. Declare that the nature of Microdea's infringement is "exceptional" pursuant to 35 U.S.C. § 285 and award R+L its costs and attorney fees; and
- F. Grant R+L such other relief as is just and proper.

Jury Demand

R+L demands a trial by jury to the extent permitted by applicable law.

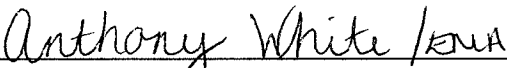
Anthony C. White (0062146)

Respectfully submitted,

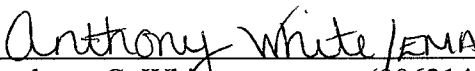
Anthony C. White (0062146)
O. Judson Scheaf, III (0040285)
Philip B. Sineneng (0083406)
THOMPSON HINE LLP
41 South High Street, Suite 1700
Columbus, Ohio 43215-6101
Tel: (614) 469-3200
Fax: (614) 469-3361
Tony.White@ThompsonHine.com
Jud.Scheaf@ThompsonHine.com
Philip.Sineneng@ThompsonHine.com

Megan D. Dortenzo (0079047)
THOMPSON HINE LLP
3900 Key Center
127 Public Square
Cleveland, OH 44114
Tel: (216) 566-5500
Fax: (216) 566-5800
Megan.Dortenzo@ThompsonHine.com

Attorneys for Plaintiff R+L Carriers, Inc.

EXHIBIT A



US006401078B1

(12) **United States Patent**
Roberts et al.

(10) **Patent No.:** US 6,401,078 B1
(45) **Date of Patent:** Jun. 4, 2002

(54) **BILL OF LADING TRANSMISSION AND PROCESSING SYSTEM FOR LESS THAN A LOAD CARRIERS**

(75) **Inventors:** Ralph L. Roberts, Reddick, FL (US);
 Steve F. Naghshineh, Cincinnati, OH (US)

(73) **Assignee:** R & L Carriers, Wilmington, OH (US)

(*) **Notice:** Subject to any disclaimer, the term of this patent is extended or adjusted under 35 U.S.C. 154(b) by 0 days.

(21) **Appl. No.:** 09/542,682

(22) **Filed:** Apr. 3, 2000

Related U.S. Application Data

(63) Continuation-in-part of application No. 09/283,032, filed on Apr. 1, 1999.

(60) Provisional application No. 60/080,365, filed on Apr. 1, 1998.

(51) **Int. Cl.⁷** G06F 17/60

(52) **U.S. Cl.** 705/28

(58) **Field of Search** 705/28

(56) **References Cited**

U.S. PATENT DOCUMENTS

| | | | |
|-------------|---------|-------------------|---------|
| 3,711,862 A | 1/1973 | Story | 700/90 |
| 3,979,731 A | 9/1976 | Naplitanov et al. | 701/118 |
| 4,360,875 A | 11/1982 | Behnke | 455/456 |
| 4,799,156 A | 1/1989 | Shavit et al. | 705/26 |
| 4,832,204 A | 5/1989 | Handy et al. | 209/3.3 |
| 4,888,692 A | 12/1989 | Gupta et al. | 700/96 |
| 5,051,914 A | 9/1991 | Sansone et al. | 700/223 |
| 5,168,444 A | 12/1992 | Cukor et al. | 705/1 |
| 5,168,451 A | 12/1992 | Bolger | 701/117 |
| 5,265,006 A | 11/1993 | Asthana et al. | 705/8 |

| | | | |
|-------------|-----------|---------------------|---------|
| 5,272,324 A | • 12/1993 | Blevins | 235/462 |
| 5,278,750 A | 1/1994 | Kaneko et al. | 705/8 |
| 5,485,369 A | 1/1996 | Nicholls et al. | 705/9 |
| 5,528,489 A | 6/1996 | Asahara et al. | 705/9 |
| 5,539,810 A | • 7/1996 | Kennedy, III et al. | 379/59 |
| 6,154,658 A | • 11/2000 | Caci | 455/466 |

FOREIGN PATENT DOCUMENTS

DE 297 00 373 • 7/1997

OTHER PUBLICATIONS

"Telex speeds container information," *Communicate for the Telecommunications User*, Dec. 1986, vol. 6, No. 11, p. 38.*
 "Portability means never being out of touch" by F. Donnelly, *Marketing*, May 23, 1991, p. 25, 28.*

* cited by examiner

Primary Examiner—Kenneth R. Rice

(74) *Attorney, Agent, or Firm*—Dinsmore & Shohl LLP

(57) **ABSTRACT**

The present invention automates the process of receiving transportation documentation and producing advance loading manifests therefrom to optimize load planning and dynamic product shipment and delivery control. Methods provide for receipt of the transportation documentation, initial preparation, and transmission of the documentation from on board a vehicle or while the vehicle is in transit. A remote processor receives the documentation, stores the documentation and feeds the documentation to a load planning software for generation of advance loading manifests from the remote processor and receive them on demand. Further, a mobile data transmission device is provided for use by a driver to communicate transportation documentation, and vehicle information to the remote processor, and, in some applications, can receive instructions for en route alterations of package pickup or delivery.

9 Claims, 8 Drawing Sheets

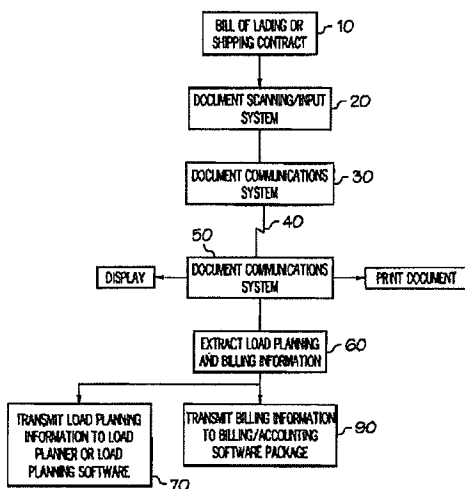

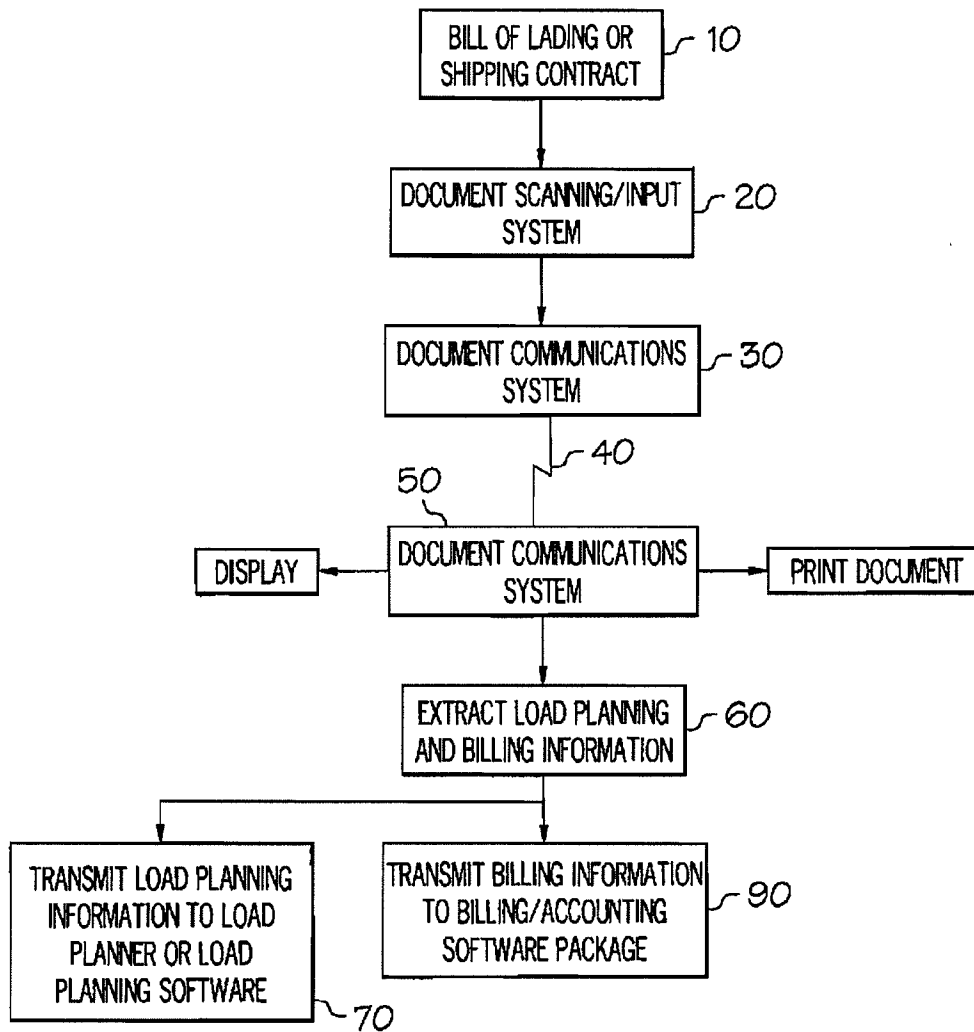

FIG. 1A

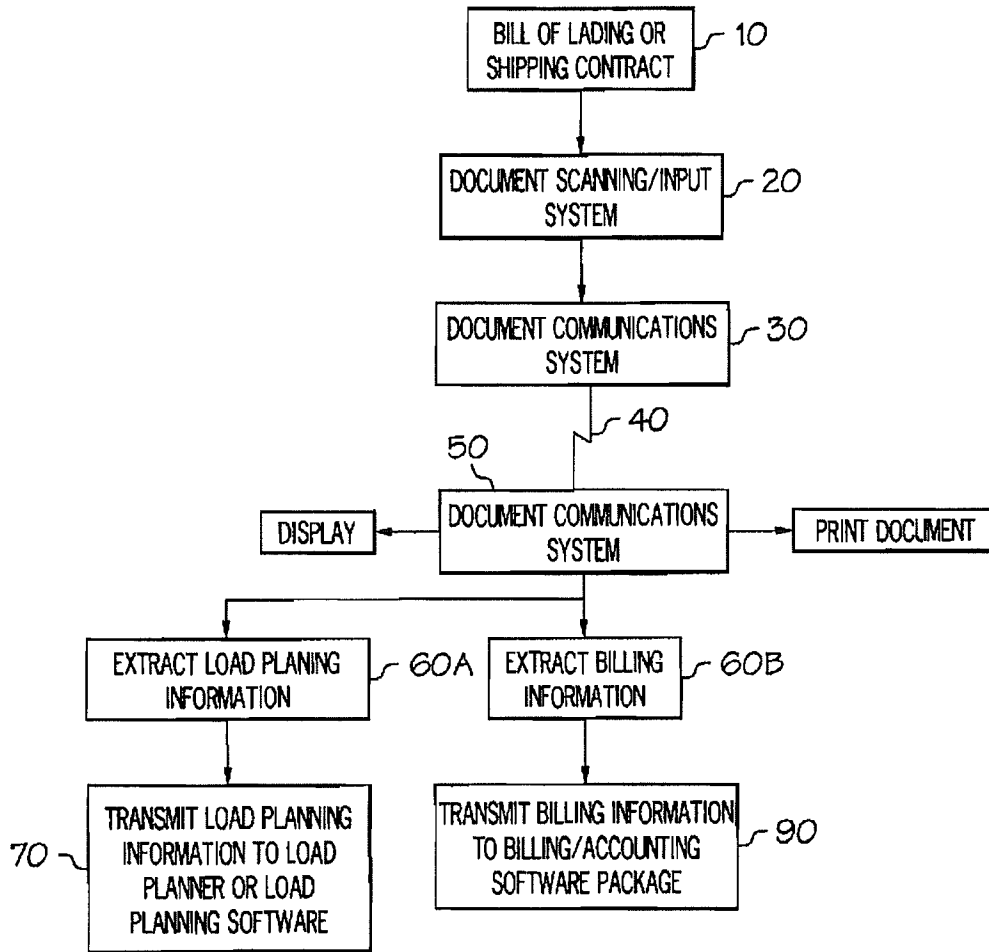

FIG. 1B

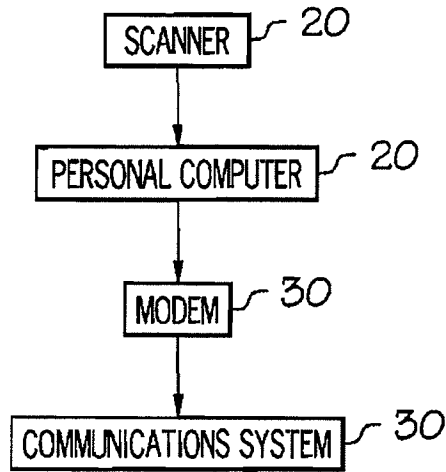

FIG. 2A

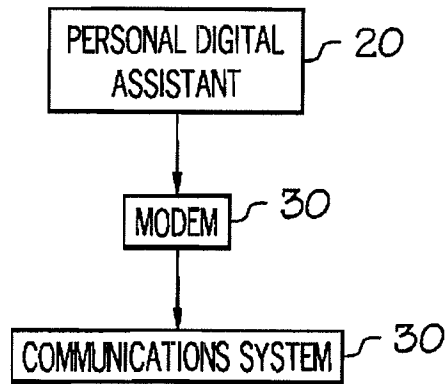

FIG. 2B

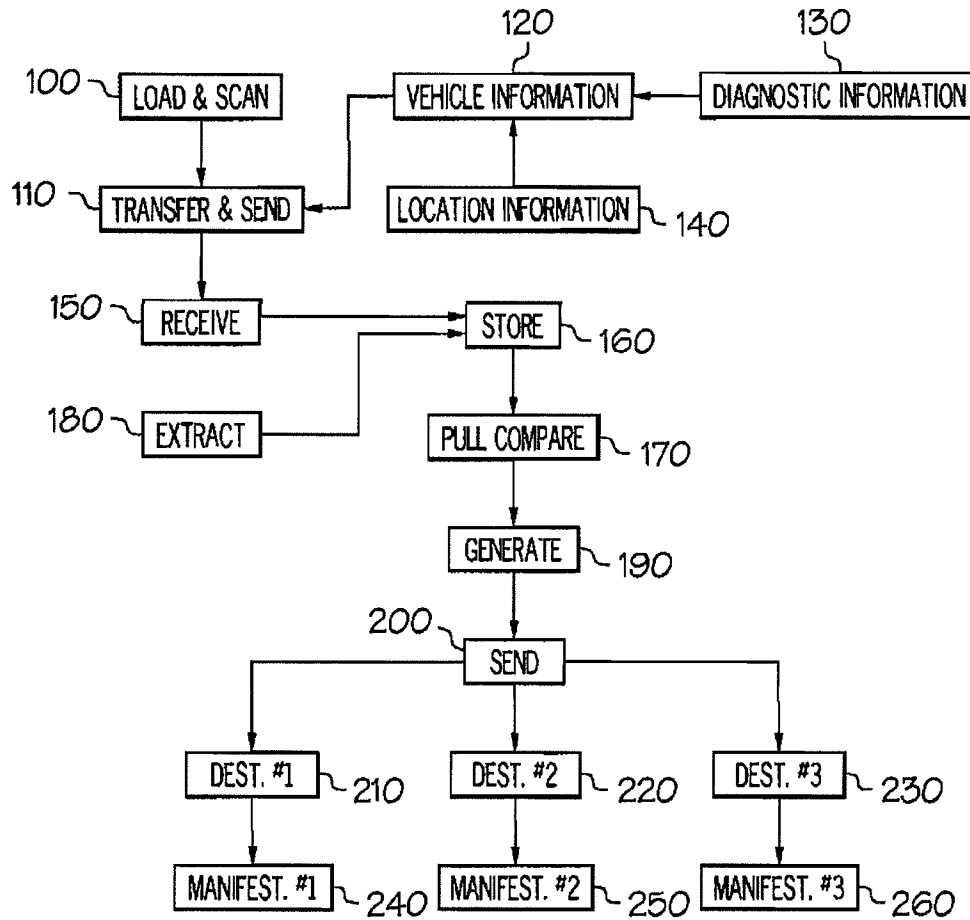

FIG. 3

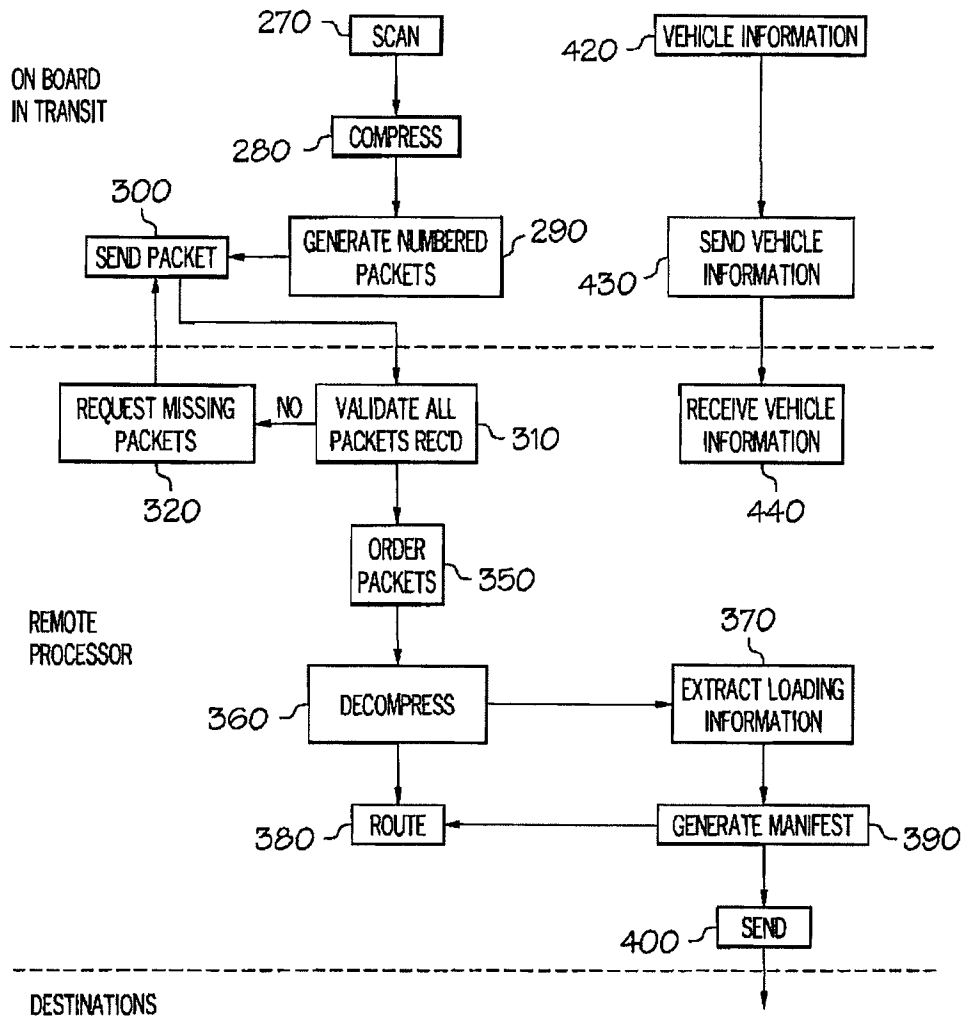

FIG. 4

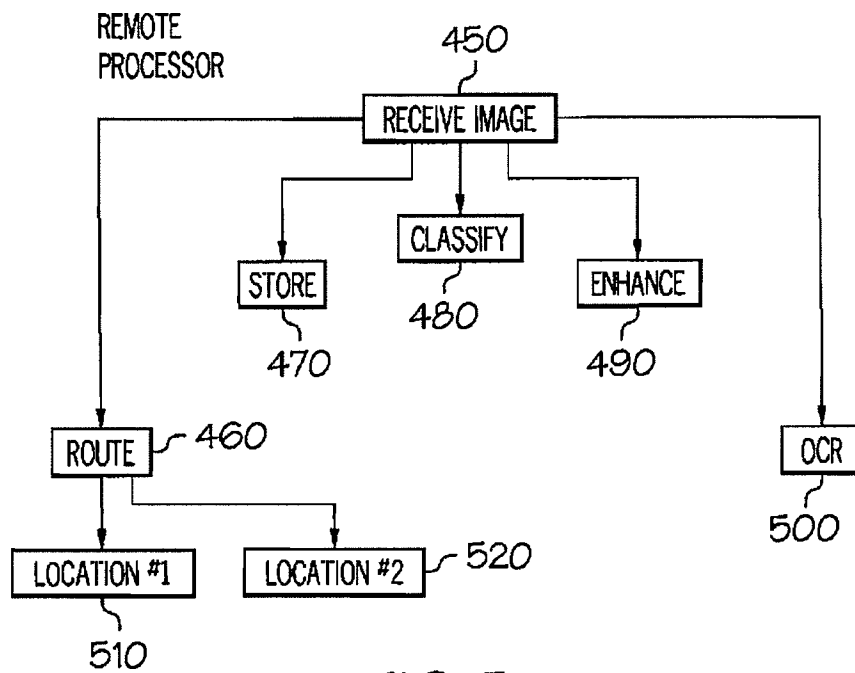

FIG. 5

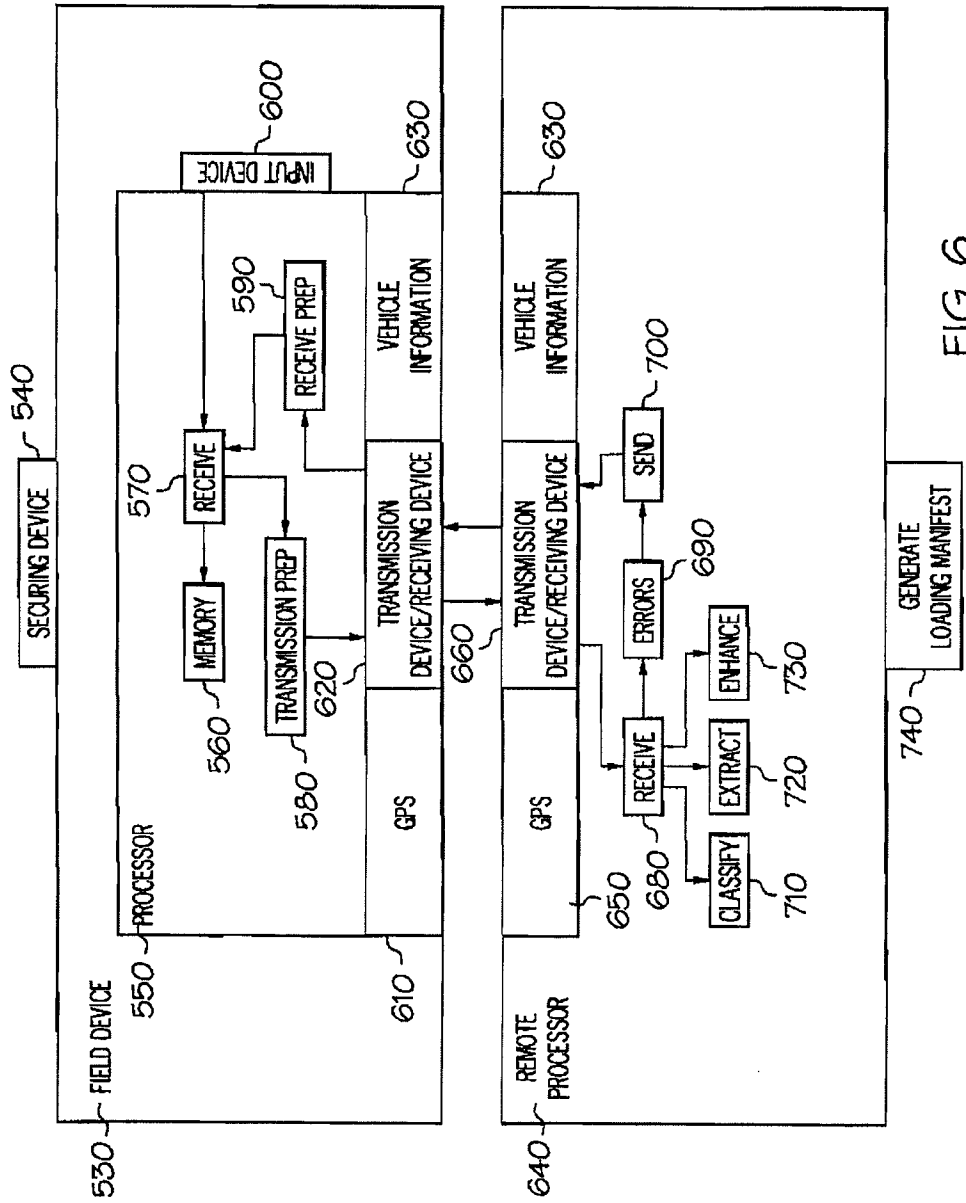

FIG. 6

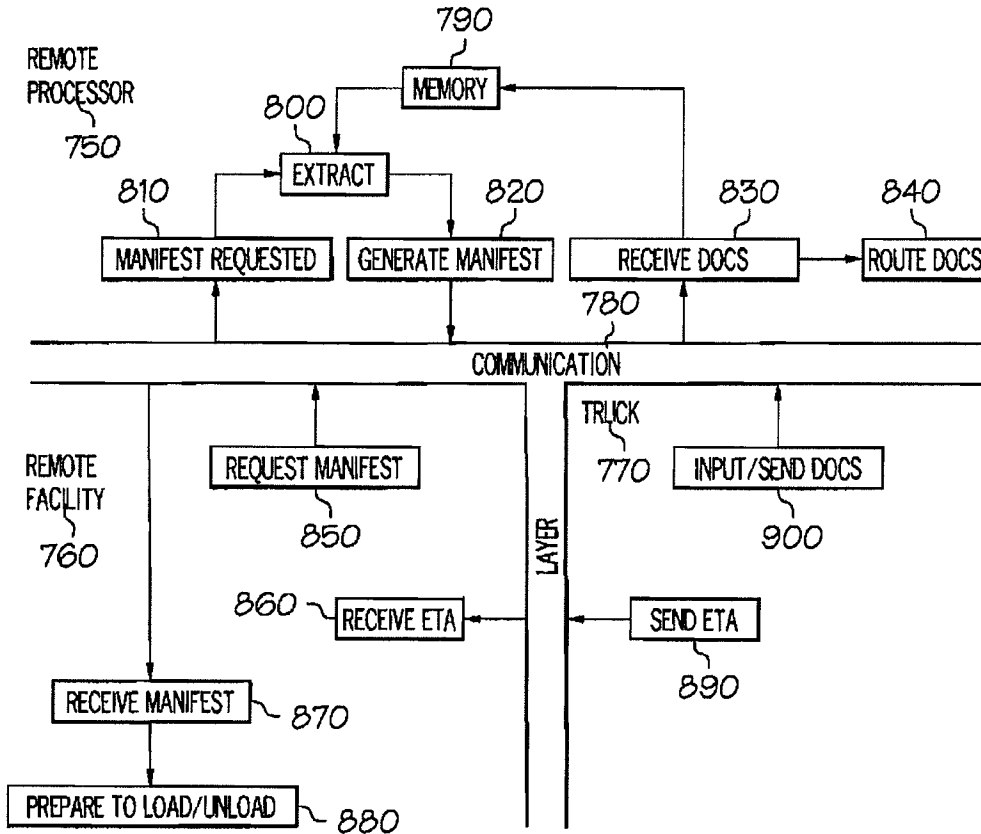

FIG. 7

US 6,401,078 B1

1

BILL OF LADING TRANSMISSION AND PROCESSING SYSTEM FOR LESS THAN A LOAD CARRIERS

This application is a continuation-in-part of United States patent application Ser. No. 09/283,032 filed Apr. 1, 1999, the disclosure of which is incorporated herein by reference. United States patent application Ser. No. 09/283,032 claims the benefit of United States Provisional Patent Application Serial No. 60/080,365 filed Apr. 1, 1998.

BACKGROUND OF THE INVENTION

1. Field of the Invention

The present invention relates generally to methods of dynamic load planning and billing used by less-than-a-load (LTL) carriers and more particularly, to a method for transmitting shipping documents or bills of lading directly from the truck driver to a common point or terminal so that billing and load planning can be accomplished while the load is being delivered from the customer.

2. General Background

The shipping industry consists primarily of three types of carriers, each offering services that satisfy different customer needs. There are small package carriers like Federal Express, United Parcel Service and others who pick up small packages, consolidate these packages into large loads, move them close to their destination point and then deliver the packages. At the opposite end of the shipping business are the large customers which fill entire trucks or trailer loads and are considered to be truck load shippers. The category in between the truck load shippers and the small package shippers are less-than-a-load (LTL) carriers. Similar to the UPS driver who collects and delivers many small packages during a business day, the less-than-a-load (LTL) carrier picks up freight from upwards of 20 different customers. This freight is typically destined to many different locations around the country. The freight is brought back to a terminal where the shipments are unloaded from the truck, consolidated with other freight moving in the same direction and then reloaded on delivery trucks. The freight is sorted and consolidated into truck loads at the terminal to minimize the empty space on the truck that will transport the freight from the local terminal to either a local delivery or a distribution terminal in another city or state. At the distribution terminal the truck will be unloaded and its freight restored and reconsolidated for delivery to customers in the local area around the distribution terminal or shipment to another distribution terminal.

Each individual shipment is governed by a separate contract called a "bill of lading". Often, customers will have their own bill of lading form that they use for shipping. Thus, over the course of a day a truck driver may collect many different bill of lading forms, one for each shipment. As in any business, efficiency and speed are measuring sticks for customer service. As an internal matter, as with any other business, the faster payment is received, the better the cash flow. The speed and efficiency of these processes are what gives a trucking or other carrier a competitive edge. Typically, a truck driver will leave the truck terminal in the morning and return in the evening. When he returns he has a hand full of bill of lading forms and other paper work which is submitted to the corporate office where it is processed by billing clerks using data entry skills. After the information from each bill of lading is entered, the shipping information is transmitted to the loading dock at the terminal so that the freight moving to common points can be consolidated and the delivery schedule planned.

2

The goal of proper load planning is to deliver the freight on time with the delivery truck leaving the terminal with a full load. Unfortunately, both the truck used to pick up the freight and the truck used to deliver the freight are often sitting idle at the terminal while the data entry and load planning functions are being performed. Additionally, because the freight typically comes in one truck at a time the loading dock may not know in advance of the trucks' arrival at the terminal or the contents and the destination of the freight picked up on a given day. Consequently, a delivery truck will often depart the terminal only partially loaded. Many of these partially loaded trucks could have been fully loaded had the load planner known about unscheduled freight that had been picked up and would soon arrive at the terminal. This movement of freight as partial also results in decreased efficiency, increased costs and reduced profits for the trucking company.

Computer software has been developed to perform load and shipping planning functions. U.S. Pat. No. 5,265,006 titled "DEMAND SCHEDULED PARTIAL CARRIERS LOAD PLANNING SYSTEM FOR THE TRANSPORTATION INDUSTRY" is an example of this type of software. Load planning software, while reducing the time expended in planning shipments, is unable by itself to reduce the inefficiency caused by partial loads that could have been full loads due to unscheduled freight, since this freight would not have been entered into the computer program.

U.S. Pat. No. 5,168,444, (Cukor), titled "SHIPMENT SYSTEM INCLUDING PROCESSING OF DOCUMENT IMAGES", is the closest prior art to the present invention. Cukor illustrates a system where the bills of lading are faxed from local shipping terminals to the shipping company's headquarters. At headquarters, where the data entry clerks could be supervised, a data entry clerk views the image of the bill of lading and enters the appropriate information in to the billing and accounting database. This system while using a fax machine, still requires that the truck driver return to a terminal before the shipping documents are sent to the company headquarters. Thus, while this system may reduce the errors made by the data entry personnel, it does not reduce the inefficiencies caused by the data entry clerks waiting for a driver to arrive at a terminal with the bills of lading and fax the bills of lading to headquarters, or the inefficiency caused by the driver waiting for the load planning to be completed.

SUMMARY OF THE INVENTION

The present invention has solved the problems described above and comprises broadly a system for transmitting bills of lading to a central facility so that billing and load planning may be accomplished while the freight is en route to a terminal, the equipment used to transmit the bill of lading from the driver to a terminal or central location, and the method for transmitting the bill of lading. There is a document input system that provides for scanning the paper bill of lading into an electronic data format or electronic bill of lading. Connected to the input system is a document transmitting system. The transmitting system transmits the electronic bill of lading to a document receiving system using a communications link. The document receiving system is connected to a document processing system. This processing system provides for the display and printing of the electronic bill of lading; for sharing the electronic bill of lading over a network; and for extracting load planning and billing information from the electronic bill of lading. The load planning data is sent to a load planner or to load planning software and the billing data is sent to a load planner or to load planning

US 6,401,078 B1

3

software and the billing data is sent to the billing clerk or accounting/billing software application. With this information in the computer system, the customer can now be billed as well as appropriate load planning can be accomplished, so that when the truck driver returns to the terminal the load planning is completed. Thus, each freight shipment can be unloaded from the truck and directly placed on the truck that will be carrying that load to its next destination. Having the load planning accomplished prior to the freight's arrival, reduces the freight turn-around time and freight handling. Additionally, since the load planner knows what freight is on its way to the terminal, fewer delivery trucks will depart with partial loads. Consequently, the trucking company would be able to move the same amount of freight at a lower cost.

BRIEF DESCRIPTION OF THE DRAWINGS

FIG. 1A is a block diagram of a load planning and billing system setup in accordance with the present invention;

FIG. 1B is a block diagram of an alternate embodiment of a system for load planning and billing similar to that shown in FIG. 1;

FIG. 2A is a functional block diagram of document scanning and transmission device using a personal computer setup in accordance with the present invention;

FIG. 2B is a functional block diagram of an electronic bill of lading transmission system setup in accordance with the present invention;

FIG. 3 is a flow diagram depicting a preferred method of transmitting shipping documentation in accordance with the present invention;

FIG. 4 is a flow diagram depicting a preferred method of processing an image in accordance with the present invention;

FIG. 5 is a diagram depicting a preferred image processing by a remote processor in accordance with the present invention;

FIG. 6 is a preferred device capable of scanning and transmitting an image to a remote processor in accordance with the present invention; and

FIG. 7 is a diagram of a preferred remote processor which dynamically generates advance loading manifests in accordance with the present invention.

DESCRIPTION OF THE PREFERRED EMBODIMENTS

FIG. 1A illustrates a bill of lading transmission and processing system for less-than-a-load (LTL) carriers in accordance with the present invention. The bill of lading transmitting and processing system 10 comprises scanning a document using a scanning/input system 20, initiating a document transmission using a communication system (transmitter) 30, establishing a connection using a communications link 40, receiving a document using a communications system (receiver) 50, extracting the load planning and billing information 60 from a transmitted electronic bill of lading, transmitting or sharing the load planning information with a load planner or load planning software 70, and transmitting or sharing the billing information extracted from the electronic bill of lading with a billing or accounting software package 90. The illustrated system is designed so that a truck driver, while en route, can transmit a bill of lading received from a customer to a central processing location where the billing and load planning information is extracted and used.

4

FIG. 1B shows an alternative version of the system described above. The only difference is that the extraction of load planning and billing information is split into two blocks. The extraction of load planning data 60A and the extraction of billing information 60B. This information is used as described above.

The document scanning/input system 20 can take many different forms. The preferred method and system comprises a portable scanner connected to a notebook computer. This computer must be capable of being interfaced with the communication system (transmitter) 30 selected by the user. Alternatively, a portable fax machine capable of being either directly or through an interface circuit connected to a variety of communications systems including but not limited to cellular telephones, radio links, satellite communication systems and standard telephone systems. If a scanner connected to a personal computer system is used, the computer must have the appropriate software as well as the appropriate PCIMA card or a built in interface for connection to any of the above communication systems (transmitter) 30. As an alternative to using a full notebook computer, a personal digital assistant (PDA) may be utilized if it has the appropriate interface capability between the scanner and the communication system 30 selected. Additionally, if customers agree to use a standard electronic form for a bill of lading or other shipping document, the form could be given to the driver on disk and then transmitted directly without the need for scanning. Furthermore, a PDA or personal computer could be programmed with an electronic form that the customer could fill out and sign while the driver was loading the shipment. After review and verification by the driver, the PDA or computer would then transmit the electronic form to the communication system. Thus, it can be readily seen that the document scanning/input system can be produced as a single unit or may be made up of several independent systems connected together.

The document communication system (transmitter) 30 and document communication system (receiver) 50 are comprised of similar equipment, such that both a transmitting device and a sending device will include a compatible software to interface with one another through transmission protocols such as TCP/IP, or any other transmission protocols. This communications equipment can be a stand alone system or can be provided as part of an integrated package with the document scanning or input system 20. The preferred packaging would be to use separate systems so that the communication systems could be upgraded or changed as technology and the trucking company requirements change. Examples of communication systems that could easily be used to transmit a signal which contains the information from the bill of lading are the following broad categories: analogue telephones; digital telephones; high frequency (HF), very high frequency (VHF), or ultra-high frequency (UHF) radio transmitters; cellular telephone; or satellite communication systems. The distance over which the communications link 40 must be reliable will determine which communication system is selected by a specific user. For short distances (line of sight), cellular telephone and VHF/UHF radio links are preferred. Medium distance transmission (line of sight to 100 miles) would typically use cellular telephones if available or HF radio links. HF radio is the least preferred communication system due to signal propagation problems. Long distance communications could use cellular telephone if available or satellite communication systems.

The use of standard or plain old telephone systems (POTS) communication circuits could be accessed using an

US 6,401,078 B1

5

acoustic coupler and a modem so that a standard telephone handset could be utilized. If it is not necessary to utilize a standard telephone handset, then just a modem with a direct connection to the telephone system would be utilized. To utilize any of the HF, VHF or UHF radio systems, a radio frequency modem would be required to be a part of the communication or communication system 50. To use cellular technology in either an analogue cellular phone or a digital cellular phone, the appropriate cabling and modems would also be required to be part of the communication systems 30 or 50.

There is a fairly broad spectrum of satellite communication systems presently available and a host of satellite communication systems that are being developed or implemented that could be utilized in the future. All of these systems will require the use of some type of radio transmitter and antenna assembly for communicating between the satellite and the truck. Depending upon the type of satellite communication equipment utilized, a radio frequency (RF) modem or some other interface may be required to be a part of the communication systems 30, 50 in order for the digital information generated by the document scanning/input system 20 to be converted into a radio signal for transmission to the satellite. Additionally, some trucks already use a satellite communication system to track the vehicle's location and communicate with the driver. If such a system is already installed the document scanning/input system 20 could interfere directly with the installed equipment.

Communication link 40 can comprise any system or method of transmitting the information from the communication system 30 to communication system receiver 50. These systems and methods include: 1) standard phones lines; 2) a combination of radio and telephone circuits, as used in a cellular telephone system; 3) a direct radio circuit, which would be employed in a situation using an HF, VHF or UHF radio link; 4) a combination of VHF or UHF radio link to a satellite with a return VHF, UHF link to a ground station, the ground station would link to a central processing facility over a telephone line, alternatively the ground station and telephone line could be replaced by a second radio link directly to the central processing facility, depending on how the satellite communication system was designed to be used.

In order to maximize the efficiency of the bill of lading transmission and processing system, the electronic bill of lading, received at the central processing facility for the trucking company must be processed to extract the load planning and billing information 60. Alternatively, the load planning information 60A and billing information 60B may be separately extracted. To extract this information, the electronic bill of lading received by the document communication system 50 would be processed to remove the applicable information from the electronic bill of lading and transmit the required information to either the load planner 70 or to the billing and accounting software package 90.

One method of extracting load planning and billing information would be to interface the document communication system 50 with a standard personal computer using the appropriate modem or interface box. The electronic bill of lading would be digitized and then processed with an optical character recognition (OCR) or intelligent character recognition (ICR) software package. The character based electronic bill of lading provided by the OCR program is then used in the load planning and billing processes. The load planning information would preferably then be transmitted to the load planner over a local area network. This infor-

6

mation could be printed and/or displayed at the load planner's terminal. As an additional time saver the load planning information 60 could be transmitted to a computer running on the local area network. This computer would run a load planning software package which would do the load consolidation and planning automatically.

A second method of extracting the load planning and billing information would be for a data entry clerk to view either a paper or electronic copy of the electronic bill of lading and manually enter the appropriate data into a computer system for load planning, billing, and accounting. If a computerized load planning system was not utilized, a paper copy of the electronic bill of lading would be printed and given to the load planner.

The billing information extracted would be transmitted or inputted into a standard billing and accounting software package which could automatically invoice the shipper so that there would be a shorter time period between picking up a load and billing the shipper. Additionally, the load planning information extracted could be transmitted or input into a load planning software package that could automatically build a shipping and loading plan to minimize partial loads and keep the shipments on time. An additional value of having the load planning and billing information automatically extracted from the electronic bill of lading is expected that fewer errors in load planning and billing would be made. In practice, this system can range from a frilly automatic, electronic, paper less system to one which relies on paper and uses the system merely as a transmission device.

FIG. 2A is a functional block diagram of a document scanning transmission device 20 using a personal computer and a scanner. Furthermore, a document communications system 30 includes a modem for transmission. Alternatively, a document scanning transmission device 20 could be created by utilizing a PDA as shown in FIG. 2B.

FIG. 3 is a flow diagram depicting a method of transmitting shipping documentation enabling dynamic load planning in accordance with the present invention. Shipping documentation is often received in paper form by the driver of a truck from a customer at the time of pickup or otherwise while the driver is delivering his/her cargo. The documentation is generally associated with a package or item to be delivered given to the driver by a customer (or completed by the driver at the time of pickup). This documentation may be supplemented by the driver with remarks, weather conditions, corrections, additional details, and otherwise updated en route as applicable. Typically, such shipping documentation includes bills of lading, and the documentation may be one to several pages in length for each package or item to be separately delivered. The term "package" will be used herein to connote any item or cargo to be shipped. Preferably, a driver will have a number of unique bar coded self adhesive stickers and each unique bar code will be replicated on two identical stickers. The driver will place one of these stickers on the package or item provided by the customer and another corresponding sticker will be placed in the upper-right-hand corner of the first page of the shipping documentation. These bar codes are preferably encoded in a machine readable format and are marked in a structured manner such that a bar code reader equipped with compatible software can readily identify information from the bar code, such as, the identification of the truck driver receiving the package, date of receipt, general location of receipt, identification of the truck, route information, or the like.

Having identified the package and the documentation, the driver loads the package onto his truck in step 100 and scans

US 6,401,078 B1

7

an image of the documentation received creating an electronic representation of the documentation. This digital representation of the documentation is then transferred to an image processor where the image is prepared for transmission in step 110. Many commercially available scanning devices are capable of creating an image of the documentation and capable of interfacing to a computing device such as a palm-top computer. In this exemplary embodiment, the palm-top computer includes an image processor which includes software logic capable of compressing the image into a smaller memory space. Compression techniques are well known in the art and any appropriate compression technique would be sufficient. The image processor also interfaces with a transmission device such as a cellular modem, wireless modem, and the like.

Prior to sending the compressed documentation, the software logic will preferably break the documentation into smaller units, or packets. These packets will generally be numbered and the total number of packets recorded as part of the processing. This will permit the computing device used by the driver, to reliably transmit to a remote processing center's computing device. Busting the documentation into smaller packets, which are then sent in Step 110, will also decrease the expense associated with transmitting the documentation should an error in transmission occur, such as loss of communication with a cell tower after 50% of the documentation was sent. Particularly, if an error is encountered, both the computing device used by the driver and the remote processing's computing device will know what packets have been received and what still needs to be received by the remote processor. Initially, the transmission device of the driver's computing device makes contact with the remote processing center's computing device and transmits the total number of packets which are to be sent. As each packet is received, the packet's number is recorded by both the receiving computing device and the sending computing device. With this information, error recovery with failed transmissions can be readily resolved.

Once the documentation is successfully received (step 150) at the selected remote processing site, the packets are ordered correctly and concatenated together to reform the document (or documents) sent, which is then decompressed. The decompressed documentation is stored on the remote processing center's computing device in step 160.

Thereafter, load plans for a destination, which may include interim and final destinations for a package, can be dynamically preformatted and manipulated by using a computing device to request from the remote processing center's computing device an advance loading manifest. Advance loading manifests, are documents generated by the load planning software discussed above. These documents provide instructions to workers at a destination, informing the workers that a particular package or item needs to be placed on a particular truck for further shipment at a particular time. Since, the load planning software is receiving documentation regarding the packages dynamically throughout delivery day, whenever the load planning software is requested to generate an advance loading manifest, the loading efficiency of the trucks is fully maximized, at that point in time. As will be understood, the inventive system enables dynamic routing of items and packages as they are en route. Optimization of transportation resources and delivery times can thereby be accomplished on a dynamic and real time basis, and shipments can be redirected to accommodate changing conditions and needs of customers, vehicles and extraneous factors (e.g., weather and traffic).

When an advance loading manifest is requested, the remote processing center's computing device, utilizing a

8

software logic, will programmatically request an extract (step 180) of all documentation relevant to generating an advance loading manifest for a requesting destination. These sets of documentation are pulled from the computing device's storage in step 170 and compared. In step 190, the relevant information contained in these sets of documentation such as package weight, package dimension, package destination, package delivery requirements, package current location, etc. are fed to the load planning software to produce one or more advance loading manifests.

The generated advance loading manifest is then transmitted by the remote processing center's computing device to the requesting destination (e.g., steps 210, 220, and 230). While it is contemplated that a single remote processing center for at least selected geographic regions, it should be understood that the processing center could also be located at a destination or interim destination, and that any number of processing centers might be utilized to service any particular geographic region. Reception of the advance loading manifest at the requesting destination may be by any acceptable electronic means such as facsimile, hand held computing devices, email, electronic bulletin boards, or direct transmission to the requesting destination's computing devices such as on a network. The requesting destinations may then view and use the generated advance loading manifests (or alternatively access the data to generate their own manifests) to optimize truck loading in steps 240, 250, and 260.

FIG. 4 is a flow diagram depicting an exemplary method of processing an image in accordance herewith. This image might be shipping data in the form of documentation provided by a customer to a driver and associated with a customer's package. It may also include comments, remarks, details, error notations, and corrections which are electronically communicated by the driver and associated with the image. The driver may add this additional data to be associated with the image, through any electronic input device interfaced to a computing device or by writing the additional data on the customer's documentation. This may be accomplished by following instructions (generated from a software program developed to obtain standard comments from the driver) on a computer screen and selecting options with an attached mouse; using a keyboard to type additional data; using a wand to write in the information on a PDA; using a pen to make notations on the documentation which will then be scanned in with the documentation; speaking into an input device interfaced to a computing device and capable of performing voice recognition operations; and transferring the additional data from one computing device to another such as using infrared transmission from a driver's PDA to the driver's main computing device.

Once the customer documentation and package are received at a pickup point, the items are labeled with bar coded stickers as discussed above with FIG. 3. Next, the driver may add additional information to the documentation itself or through the driver's computing device. The documentation is then scanned into the driver's computing device in step 270. An electronic image is created of the documentation which includes any driver added information. This image is then compressed in step 280, and preferably divided into smaller units or packets in step 290. Each packet is then sent in step 300, and if a remote processor indicates a packet was not received properly in step 320, the packet in question is resent in step 300 until successful completion.

Simultaneously, the driver's main computing device is preferably capable of recording or receiving information

US 6,401,078 B1

9

about the transportation vehicle in step 420. This information might include, mechanical performance of the vehicle (e.g., engine temperature, oil pressure, fluid levels, tire pressure, and the like), location of the vehicle, weather conditions, speed of travel, direction of travel, and the like. This vehicle information is sent to the remote processor in step 430.

Steps 270, 280, 290, 300, 420, and 430 all occur while the driver is on board the transportation vehicle or while the truck is in transit. While the scanning step (270) may be undertaken prior to departing a pickup location (e.g., where there is only a single driver), this step might preferably be performed while en route by using an automatic feed/scanning arrangement, or where another person on board can complete the scans en route. The phrase "on board" is intended to connote the fact that the equipment will travel with the driver and vehicle, and is not limited to any particular location. Therefore, the driver could transmit customer documentation or vehicle information from a PDA or device that can be carried with him outside of the truck cab, or could use the equipment to scan and transmit from physically being in the vehicle itself. Moreover, sending the customer documentation and vehicle information can occur while the driver is actually driving the transportation vehicle, as mentioned. Once all information is stored electronically, preferably no further actions are required by the driver to ensure the information is sent to the remote processor, since this can all be coordinated with executable instructions residing on the driver's computing device and the remote processor's computing device. This frees the driver to continue with his deliveries with minimal interruption and delay, and requires very minimal training of the driver.

The remote processor initially validates that all packets are received in step 310. If packets are not fully received, the sending transportation vehicle to will resend a missing packet in step 320. Once all packets are received, they are assembled in the appropriate order in step 350 and decompressed in step 360. Based on the bar coded label associated with the documentation, the documentation may be routed to different work processing queues. Work processing queues are electronic locations where certain operations are to be performed based upon the receipt of the documentation; For example, the loading information contained in the documentation may be electronically transmitted to another remote location so that the image of the documentation may be manually keyed into an electronic text format for use in load planning software discussed above. Moreover, billing information may be manually keyed into a software billing system.

The work processing queues need not be local to the processor sending the documentation. In this way, the documentation may be routed to work processing queues any where in the world, where for instance labor is less expensive and more abundant. For example, the documentation may be routed to India, China, Indonesia, or the Philippines so that the documentation can be manually keyed at a lower cost. Furthermore, this routing to different time zones permits documentation to be processed 24 hours a day, since many of the recited countries above are working while much of the United States sleeps.

Alternatively, image data which is well fielded or structured may have the loading data programmatically extracted out of the image in step 370 and then inputted to a load planning software for generation of an advance loading manifest in step 390. Finally, in step 400 the generated advanced loading manifest can be directed to remote destinations upon request.

10

Moreover, as one skilled in the art will appreciate the load planning software need not reside exclusively on the remote processor, this software may reside on the computing device or devices of the remote facilities themselves. In these situations, the documentation may initially route through the remote processor but, the processing of the documentation and the generation of the advance loading manifest could occur at the requesting remote facility. Furthermore, if a particular set of documentation is rerouted to a new facility, it may be recalled from the remote facility's computing device by the remote processor and routed to the new facility appropriately. In this way, the remote facility provides a central dynamic routing of the documentation yet, the processing of the documentation occurs when and where it is needed.

FIG. 5 a diagram depicting an exemplary image processing by a remote processor such as a central processing system. In step 450 an image is received by the remote processor and based on its bar code routed in step 460 to multiple work queue locations 510 and 520. The image is also sorted for storage when received on the remote processor in step 470. The image is classified in step 480. Classification of the image is preferred so that the image received can be associated with other images which are relevant to a particular destination or a particular searchable characteristic (e.g. type of item, model of product, and the like). For example, if transportation vehicles 1 and 2 each receive documentation pertaining to packages received while the drivers are performing deliveries, and both vehicle 1 and vehicle 2 are arriving at a loading/unloading destination, the images from each of these transportation vehicles would be associated together by a classification means. In a common scenario, this classification means might use the bar code on the images to identify the tracks sending the images and then to store the images in a directory associated with the destination of these two transportation vehicles. The items or packages might also be classified as to the type of product, color, model number, etc., so that an individual item could be identified and (for example) redirected to an alternate destination while en route. Once the loading information from these images are appropriately extracted or manually keyed from these images, the information is passed to a load planning software package for generation of an advance loading manifest.

Moreover, a received image (e.g. as in FIG. 5) maybe programmatically enhanced by commercially available software, such as InputAccel, to provide for better image quality or resolution by performing operations such as despeckling, cropping, and improving image brightness. Improved image quality will permit more accurate automatic processing and/or manual keying of the information included on the image. Furthermore, the image may have an OCR process (step 500) performed on it permitting automatic generation of electronic text associated with the image. This electronic text could then be programmatically inputted to a load planning software for generating advance loading manifests.

InputAccel also performs work flow processing of the image by monitoring directories contained on the computing device and identifying images when the images become available in the directories. For example, types of images can be identified by the image file name extension and automatic operations can be performed on the images based on the directory in which they appear and their file names. In this way, the images are programmatically processed upon receipt by the remote processor and the load planning information associated therewith is dynamically available

US 6,401,078 B1

11

when an advance loading manifest is requested. This automation reduces the amount of personnel required to process loading documentation, reduces errors associated with manual processing, and substantially increases the efficiency of generating advance loading manifest.

FIG. 6 illustrates a schematic example of a device capable of scanning and transmitting an image to a remote processor in accordance with the present invention. Although FIG. 6 depicts a diagram as a single device, as one skilled in the art will appreciate, this arrangement need not be a single device but could be several devices which interface together to form a logical device depicted in FIG. 6. FIG. 6 depicts a field device 530 referred to as a mobile data transmission device ("MDT"). The MDT 530 has a processor 550 which includes a memory 560 and set of executable instructions residing on the processor 560 capable of receiving transportation documentation in 570 from an input device 600 which is interfaced to the processor 550. This input device 600 might preferably include a scanner which electronically converts transportation documentation into an electronic image. However, if the transportation document is already in image form and contained on a separate device such as a PDA, the input device could be an infrared transmission port which is capable of receiving the image from a device such as a PDA. After receipt of the image, the image is stored in the memory 560 and prepared for transmission in 580. Preparation for transmission includes establishing a communication with the transmission/receiving device 620, and, preferably, compressing the image. The transmission device 620 will then electronically send the image to a remote processor 640 by establishing a connection with the remote processor's 640 transmission/reception device 660.

Furthermore, the MDT 530 may include a global positioning satellite ("GPS") device 610 interfaced to the processor 550 for relaying location information to the remote processor's 640 GPS 650. Moreover, vehicle information 630 associated with the MDT 530 is communicated to the processor 550 and transmitted to the remote processor 640. Vehicle information can include any of a variety of performance, diagnostic, and status information as discussed above with FIG. 3 and is useful in creating better real time communication and planning of shipping manifests and loading and delivery schedules. The GPS will provide location information of the transportation vehicle (and the items and packages) and directions to the driver of the transportation vehicle. Additionally, the MDT 530 may contain a Radio Frequency Identification (RFID) tag, such that the MDT 530 can be continuously located with wireless transmission.

The MDT 530 may be built into the transportation vehicle itself, or it may be a separate device which can be removed from the transportation vehicle with or separate from the balance of the processing system. FIG. 6 depicts a securing device 540 which permit a removable MDT 530 to be attached to the transportation vehicle during transit, this may include an electronic connection similar to laptop computer docking stations, and would permit the MDT 530 to receive power. Power to the MDT may be supplied through a battery source, and can be connected to the transportation vehicle's battery utilizing the securing device 540.

The MDT's 530 transmission/receiving device 620 establishes a communication with a remote processor's 640 transmission/receiving device 660. Once this communication is established, the MDT 530 may transmit transportation documentation, vehicle information, and/or location information. Moreover, the MDT 530 may receive information from the remote processor 640, such as requests to resend

12

parts of the transportation documentation not successfully received by the remote processor 640, or for location updates and/or other vehicle information. Further, the remote processor may send electronic instructions to the driver via the MDT 530 utilizing the MDT's 530 GPS 610. Information received by the MDT 530 is processed in 590 by the MDT's 530 processor 550. Once received information is in a format understandable to the processor 550, it is available for use by the processor 550 and may be communicated to the driver if necessary, through a user display screen, paper print out, or by audio device. For example, additional pickups or rerouting instructions for one or more items to be delivered might be sent to allow redirecting of one or more items en route.

Transportation documentation sent by the MDT 530 is preferably received by the remote processor 640. A set of executable instructions residing on the remote processor 640 initially receives the transportation documentation in 680. If errors 690 are detected, a send 700 request is initiated causing an instruction to be sent from the remote processor's 640 transmission/receiving device 660 to the MDT's 530 transmission/receiving device 620. This instruction informs the MDT of the exact parts of the transportation document which need to be resent. Preferably, no driver intervention or action is required to effectuate the resending of the transportation documentation.

Once the remote processor 640 successfully receives a set of transportation documents, it may be electronically routed to perform a variety of operations such as classification 710, extracting 720 (loading or billing information), and enhancements 730 (e.g., improving image quality by varying brightness), and, of course, load planning and shipping manifests.

Whenever a request is made of the remote processor 640 for an advance loading manifest, the request will route to load planning software where an advance loading manifest 740 is produced for further electronic transmission or hard-copy output.

FIG. 7 is a schematic illustration of an exemplary remote processor 750 for dynamically generating advance loading manifests. FIG. 7 also depicts the overall process of the present invention. The remote processor 750 includes a set of executable instructions permitting it to interface with one or more remote facilities' (e.g. 760) computing device and a truck's (e.g. truck 770) computing device through a software communication layer 780. This software communication layer 780 might preferably include standard protocols available in the art which permit computing devices to interface with one another such as TCP/IP.

Initially, transportation documents are sent from the truck 770 (e.g. as shown at block 900) via communication layer 780. The remote processor 750 receives the documents in 830 and proceeds to route the documents in block 840 and store them to the memory of the processor in block 790. Routing the documents in this way can permit additional operations to occur on the documents such as manual keying, OCR, classification, and image enhancements. As previously discussed, commercially available software such as InputAccel provides this automated routing and operation execution on the received documentation. Moreover, as one skilled in the art will appreciate, information regarding the contents of the document could also be stored in a database and the contents of that database made available to the remote facilities and trucks on demand.

Throughout the actual pickup/delivery travel of the truck 770, an estimated time of arrival ("ETA") can be commu-

US 6,401,078 B1

13

nicated from the truck 770 to the remote facility 760 via the communication layer 780. The remote facility 760 receives the ETA in 860 and makes a determination at some point to request a loading manifest 850 from the remote processor 750 via the communication layer 780. Alternatively, such 5
ETA can be determined by the remote processor as a result of updated vehicle information received from the truck 770. The remote processor receives this request of the remote facility 760 in block 810 and causes an extraction of all the relevant load planning documents from the remote processor's 750 memory 790 in block 800. This extracted load planning data is fed to a load planning software causing an advance loading manifest to be generated in block 820. Once the advance loading manifest is generated, it is sent to the requesting remote facility 760 in block 870 via the communication layer and used in 880 to load and unload (as appropriate) the arriving truck 770. 10
15

As one skilled in the art will appreciate, the ability to bi-directionally and dynamically communicate with transportation vehicles and to remotely process transportation documentation, tremendously optimizes the performance of the transportation business, as well as allowing more freedom and control in optimizing delivery times and costs for products. Although specific examples and descriptions have been expressed as they might relate to the less-than-a-load 20
25
freight business, the usefulness of the present invention is not intended to be limited thereto. Full load shipments of products might also be improved where redirection of the vehicle and/or portions of the load en route may be desirable to respond to customer needs or other factors. 30

The foregoing description of the preferred embodiment of the invention has been presented for purposes of illustration and description. It is not intended to be exhaustive nor to limit the invention to the precise form disclosed. Many alternatives, modifications, and variations will be apparent 35
40
to those skilled in the art in light of the above teaching. Accordingly, this invention is intended to embrace all alternatives, modifications, and variations that fall within the spirit and broad scope of the amended claims.

What is claimed is:

1. A method for transferring shipping documentation data for a package from a transporting vehicle to a remote processing center:
placing a package on the transporting vehicle;
using a portable document scanner to scan an image of the documentation data for the package, said image including shipping details of the package; 45

14

- providing a portable image processor capable of wirelessly transferring the image from the transporting vehicle;
wirelessly sending the image to a remote processing center;
receiving the image at said remote processing center; and
prior to the package being removed from the transporting vehicle, utilizing said documentation data at said remote processing center to prepare a loading manifest which includes said package for further transport of the package on another transporting vehicle.

2. The method of claim 1, further comprising the step of comparing and combining the documentation data received at said remote processing center with similar shipping documentation data of other packages to be delivered from an interim destination and other shipping data, and preparing loading manifests to optimize the loads to be shipped on at least one other transporting vehicle.

3. The method of claim 1, wherein the image sending step is accomplished from onboard the transporting vehicle.

4. The method of claim 3, wherein the image sending step can be undertaken while the transporting vehicle is in transit.

5. The method of claim 4, further comprising the step of dynamically updating the documentation data sent while the transportation vehicle is in transit to provide more current data on the shipping status of the package.

6. The method of claim 1, further comprising the step of routing certain portions of the shipping documentation data received at said remote processing center to an interim destination of said package for utilization in loading manifests.

7. The method of claim 1, further comprising the step of sending vehicle information to said remote processing center at one or more times as said transporting vehicle is en route to a destination.

8. The method of claim 6, wherein said vehicle information includes location data about said transportation vehicle for use in determining loads to be shipped on at least one other transportation vehicle to be loaded at an interim destination.

9. The method of claim 6, wherein the method further comprises receiving instructions on board said transportation vehicle for altering the routing of a package on said transportation vehicle en route.

* * * * *