

1 J. Donald McCarthy (SBN 69864)
2 Audra L. Thompson (SBN 218479)
3 **DUANE MORRIS LLP**
4 865 S. Figueroa Street, Suite 2400
5 Los Angeles, CA 90017-5450
6 Telephone: (213) 689-7400
7 Facsimile: (213) 689-7401
8 E-mail: jdmccarthy@duanemorris.com
9 athompson@duanemorris.com

10 Gregory M. Luck (SBN 163750)
11 **DUANE MORRIS LLP**
12 1330 Post Oak Blvd., Suite 800
13 Houston, Texas 77056-3166
14 Telephone: (713) 402-3900
15 Facsimile: (713) 402-3901
16 E-mail: gmluck@duanemorris.com

17 Attorneys for Plaintiff Princeton
18 Digital Image Corporation

19 **UNITED STATES DISTRICT COURT**
20 **CENTRAL DISTRICT OF CALIFORNIA**
21 **WESTERN DIVISION**

22 PRINCETON DIGITAL IMAGE
23 CORPORATION,
24
25 Plaintiff,
26
27 v.
28
29 ACTIVISION PUBLISHING, INC.,
30
31 Defendant.

32 **CV12-01134** VBK
33 Case No: _____

34 **COMPLAINT FOR PATENT**
35 **INFRINGEMENT**
36 **DEMAND FOR JURY TRIAL**

37
38
39
40
41
42
43
44
45
46
47
48
49
50
51
52
53
54
55
56
57
58
59
60
61
62
63
64
65
66
67
68
69
70
71
72
73
74
75
76
77
78
79
80
81
82
83
84
85
86
87
88
89
90
91
92
93
94
95
96
97
98
99
100
101
102
103
104
105
106
107
108
109
110
111
112
113
114
115
116
117
118
119
120
121
122
123
124
125
126
127
128
129
130
131
132
133
134
135
136
137
138
139
140
141
142
143
144
145
146
147
148
149
150
151
152
153
154
155
156
157
158
159
160
161
162
163
164
165
166
167
168
169
170
171
172
173
174
175
176
177
178
179
180
181
182
183
184
185
186
187
188
189
190
191
192
193
194
195
196
197
198
199
200
201
202
203
204
205
206
207
208
209
210
211
212
213
214
215
216
217
218
219
220
221
222
223
224
225
226
227
228
229
230
231
232
233
234
235
236
237
238
239
240
241
242
243
244
245
246
247
248
249
250
251
252
253
254
255
256
257
258
259
260
261
262
263
264
265
266
267
268
269
270
271
272
273
274
275
276
277
278
279
280
281
282
283
284
285
286
287
288
289
290
291
292
293
294
295
296
297
298
299
300
301
302
303
304
305
306
307
308
309
310
311
312
313
314
315
316
317
318
319
320
321
322
323
324
325
326
327
328
329
330
331
332
333
334
335
336
337
338
339
340
341
342
343
344
345
346
347
348
349
350
351
352
353
354
355
356
357
358
359
360
361
362
363
364
365
366
367
368
369
370
371
372
373
374
375
376
377
378
379
380
381
382
383
384
385
386
387
388
389
390
391
392
393
394
395
396
397
398
399
400
401
402
403
404
405
406
407
408
409
410
411
412
413
414
415
416
417
418
419
420
421
422
423
424
425
426
427
428
429
430
431
432
433
434
435
436
437
438
439
440
441
442
443
444
445
446
447
448
449
450
451
452
453
454
455
456
457
458
459
460
461
462
463
464
465
466
467
468
469
470
471
472
473
474
475
476
477
478
479
480
481
482
483
484
485
486
487
488
489
490
491
492
493
494
495
496
497
498
499
500
501
502
503
504
505
506
507
508
509
510
511
512
513
514
515
516
517
518
519
520
521
522
523
524
525
526
527
528
529
530
531
532
533
534
535
536
537
538
539
540
541
542
543
544
545
546
547
548
549
550
551
552
553
554
555
556
557
558
559
560
561
562
563
564
565
566
567
568
569
570
571
572
573
574
575
576
577
578
579
580
581
582
583
584
585
586
587
588
589
590
591
592
593
594
595
596
597
598
599
600
601
602
603
604
605
606
607
608
609
610
611
612
613
614
615
616
617
618
619
620
621
622
623
624
625
626
627
628
629
630
631
632
633
634
635
636
637
638
639
640
641
642
643
644
645
646
647
648
649
650
651
652
653
654
655
656
657
658
659
660
661
662
663
664
665
666
667
668
669
670
671
672
673
674
675
676
677
678
679
680
681
682
683
684
685
686
687
688
689
690
691
692
693
694
695
696
697
698
699
700
701
702
703
704
705
706
707
708
709
710
711
712
713
714
715
716
717
718
719
720
721
722
723
724
725
726
727
728
729
730
731
732
733
734
735
736
737
738
739
740
741
742
743
744
745
746
747
748
749
750
751
752
753
754
755
756
757
758
759
760
761
762
763
764
765
766
767
768
769
770
771
772
773
774
775
776
777
778
779
780
781
782
783
784
785
786
787
788
789
790
791
792
793
794
795
796
797
798
799
800
801
802
803
804
805
806
807
808
809
810
811
812
813
814
815
816
817
818
819
820
821
822
823
824
825
826
827
828
829
830
831
832
833
834
835
836
837
838
839
840
841
842
843
844
845
846
847
848
849
850
851
852
853
854
855
856
857
858
859
860
861
862
863
864
865
866
867
868
869
870
871
872
873
874
875
876
877
878
879
880
881
882
883
884
885
886
887
888
889
890
891
892
893
894
895
896
897
898
899
900
901
902
903
904
905
906
907
908
909
910
911
912
913
914
915
916
917
918
919
920
921
922
923
924
925
926
927
928
929
930
931
932
933
934
935
936
937
938
939
940
941
942
943
944
945
946
947
948
949
950
951
952
953
954
955
956
957
958
959
960
961
962
963
964
965
966
967
968
969
970
971
972
973
974
975
976
977
978
979
980
981
982
983
984
985
986
987
988
989
990
991
992
993
994
995
996
997
998
999
1000

FILED

Princeton Digital Image Corporation (hereafter "Princeton" or "Plaintiff," brings this action against Activision Publishing, Inc. (hereafter "Activision" or "Defendant"), and alleges that:

1 1. This is an action for patent infringement under Title 35, U.S.C. Sections
2 271, et. seq., over which this court has jurisdiction under 28 U.S.C. §§ 1338 and
3 1338(a).

4 **I.**

5 **PARTIES**

6 2. Plaintiff Princeton Digital Corporation is a corporation organized and
7 doing business under the laws of the State of Texas, having its offices at 911 NW
8 Loop 281, Suite 211-213, Longview, Texas 75604.

9 3. On information and belief, Defendant Activision Publishing, Inc. is a
10 corporation organized and existing under the laws of the State of Delaware, with its
11 principal place of business in the State of California, located at 3100 Ocean Park
12 Boulevard, Santa Monica, California 90405.

13 **II.**

14 **JURISDICTION AND VENUE**

15 4. This Court has personal jurisdiction over Defendant because Defendant
16 resides and is doing business in this judicial district.

17 5. Venue is proper in this district because Defendant is headquartered and is
18 doing business in this district, a number of witnesses are located in this district, and a
19 substantial portion of the events giving rise to this action occurred within this district.

20 **III.**

21 **BACKGROUND**

22 6. On April 30, 1996, U.S. Patent No. 5,513,129 (hereafter “the ‘129
23 patent”) was duly and legally issued to Mark Bolas, Ian E. McDowall and Michael N.
24 Bolas, as the inventors thereof, and is valid and subsisting. A copy of the ‘129 patent,
25 which is entitled “Method and System for Controlling Computer-Generated Virtual
26 Environment in Response to Audio Signals”, is attached hereto as Exhibit “A”.

27 7. Mssrs. Bolas, McDowall and Bolas assigned their rights to the ‘129
28 patent to Fakespace, Inc. The ’129 patent was subsequently assigned back to

1 Mssrs. Bolas, McDowall and Bolas. The '129 patent was then assigned to Nevada
2 Engineers Irrevocable Trust who then subsequently assigned the '129 patent to Visual
3 Audio LLC. Visual Audio LLC assigned all rights, title and interest in and to the '129
4 patent to Princeton Digital Image Corporation.

5 IV.

6 **INFRINGEMENT OF THE '129 PATENT**

7 8. Upon information and belief, Defendant has infringed one or more claims
8 of the '129 patent by having performed, without authority to do so, one or more of the
9 following acts: (a) offering for sale, or selling within the United States products
10 including, but not limited to, the Guitar Hero line of electronic games that infringe one
11 or more claims of the '129 patent, in violation of 35 U.S.C. § 271(a); and (b) making
12 or using within the United States products including, but not limited to, the Guitar
13 Hero line of electronic games, that infringe one or more claims of the '129 patent, in
14 violation of 35 U.S.C. § 271(a).

15 9. Upon information and belief, Defendant's acts of infringement of the
16 '129 patent are both deliberate and willful.

17 10. Princeton is entitled to recover from Defendant those damages sustained
18 as a result of Defendant's wrongful acts of infringement of the '129 patent in an
19 amount subject to proof at trial.

20 V.

21 **PRAYER AND RELIEF**

22 WHEREFORE, PREMISES CONSIDERED, Princeton prays for the following
23 relief:

24 1. That Princeton recover damages from Defendant resulting from
25 Defendant's infringement, and that said damages be enhanced in view of Defendant's
26 willful and wanton conduct;

27 2. That Princeton recover interest and costs pursuant to 35 U.S.C. § 284 and
28 attorneys' fees pursuant to 35 U.S.C. § 285; and

3. That Princeton have such other and further relief as the Court deems just
and proper under the circumstances.

Dated: February 9, 2012

DUANE MORRIS LLP

J. Donald Mc Carthy
J/Donald McCarthy
Gregory M. Luck
Audra L. Thompson

Diane M. Sangalli (*pro hac vice* to be filed)
E-mail: dmsangalli@duanemorris.com
Wesley W. Yuan (*pro hac vice* to be filed)
E-mail: wwyyuan@duanemorris.com

Duane Morris LLP
1330 Post Oak Blvd., Suite 800
Houston, Texas 77056-3166
Telephone: (713) 402-3900
Facsimile: (713) 402-3901

Samuel W. Apicelli
(*pro hac vice* to be filed)
swapicelli@duanemorris.com

Duane Morris LLP
30 South 17th Street
Philadelphia, PA 19103
Telephone: (215) 979-1000
Telephone: (215) 979-1020

Attorneys for Plaintiff
Princeton Digital Image Corporation

1
2
3
4
5
6
7
8
9
10
11
12
13
14
15
16
17
18
19
20
21
22
23
24
25
26
27
28

1
2
3
4
5
6
7
8
9
10
11
12
13
14
15
16
17
18
19
20
21
22
23
24
25
26
27
28

DEMAND FOR JURY TRIAL

Plaintiff Princeton hereby demands trial by jury of all issues so triable.

DUANE MORRIS LLP

Dated: February 9, 2012



J. Donald McCarthy
Gregory M. Luck
Audra L. Thompson



US005513129A

United States Patent [19]

Bolas et al.

[11] **Patent Number:** 5,513,129

[45] **Date of Patent:** Apr. 30, 1996

[54] **METHOD AND SYSTEM FOR CONTROLLING COMPUTER-GENERATED VIRTUAL ENVIRONMENT IN RESPONSE TO AUDIO SIGNALS**

[75] **Inventors:** Mark Bolas; Ian E. McDowall, both of Palo Alto; Michael N. Bolas, Los Angeles, all of Calif.

[73] **Assignee:** Fakespace, Inc., Menlo Park, Calif.

[21] **Appl. No.:** 91,650

[22] **Filed:** Jul. 14, 1993

[51] **Int. Cl.⁶** G06F 17/00

[52] **U.S. Cl.** 364/578

[58] **Field of Search** 364/578, 514, 364/DIG. 1, DIG. 2; 360/14.2; 340/712; 358/81, 82; 345/156; 84/645, 610, 464 R, 601, 602, 609, 611, 634, 635, 641, 642, DIG. 1, DIG. 2, DIG. 29; 395/152, 153, 154, 155, 156, 157, 159, 161, 200

[56] **References Cited**

U.S. PATENT DOCUMENTS

3,490,328	1/1970	King	84/464
3,609,019	9/1971	Tuber	369/13.5
3,617,647	11/1971	Maier et al.	369/13.5
3,900,886	8/1975	Coyle	358/82
4,081,829	3/1978	Brown	358/82
4,182,214	1/1980	Wakeman	84/DIG. 29
4,257,062	3/1981	Meredith	358/81
4,267,561	5/1981	Karpinsky	358/82
4,768,086	8/1988	Paist	358/81
4,988,981	1/1991	Zimmerman et al.	340/709
5,148,154	9/1992	MacKay et al.	395/155

5,307,456	4/1994	MacKay	395/154
5,319,452	6/1994	Funahashi	84/464 R

FOREIGN PATENT DOCUMENTS

2142461	1/1985	United Kingdom	84/610
W092/09948	6/1992	WIPO	G06F 3/03

OTHER PUBLICATIONS

Jacobson, et al., "Time for Technojuju," *NewMedia*, p. 18, Jan. 1993.

Primary Examiner—Ellis B. Ramirez
Attorney, Agent, or Firm—Limbach & Limbach; Alfred A. Equitz

[57] **ABSTRACT**

A method and apparatus for the control and manipulation of a virtual environment (such as virtual objects therein) in response to a music signal. The music is either interpreted directly to effect the control and manipulation. Alternatively, a control track corresponding to an audio signal (such as a music signal) is prerecorded, played back with the audio signal, and the control track is processed to control and manipulate the virtual world (or to control some other process of a computer system) as the audio signal is playing. In preferred embodiments, a computer creating a virtual world interprets the music, the control track, or both, and uses the resulting information to modify, create, and or control objects in the virtual environment. Preferred embodiments of the inventive system include apparatus for delaying input music to compensate for lag introduced by the system components, such as delay required to implement processing of control tracks corresponding to the input music.

23 Claims, 7 Drawing Sheets

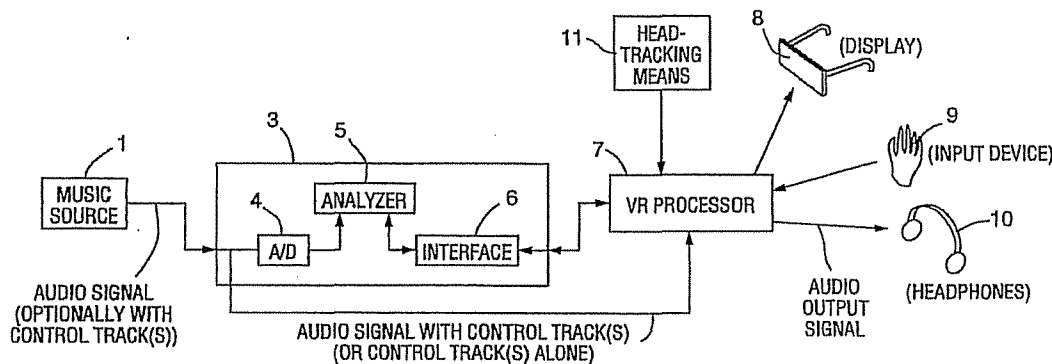

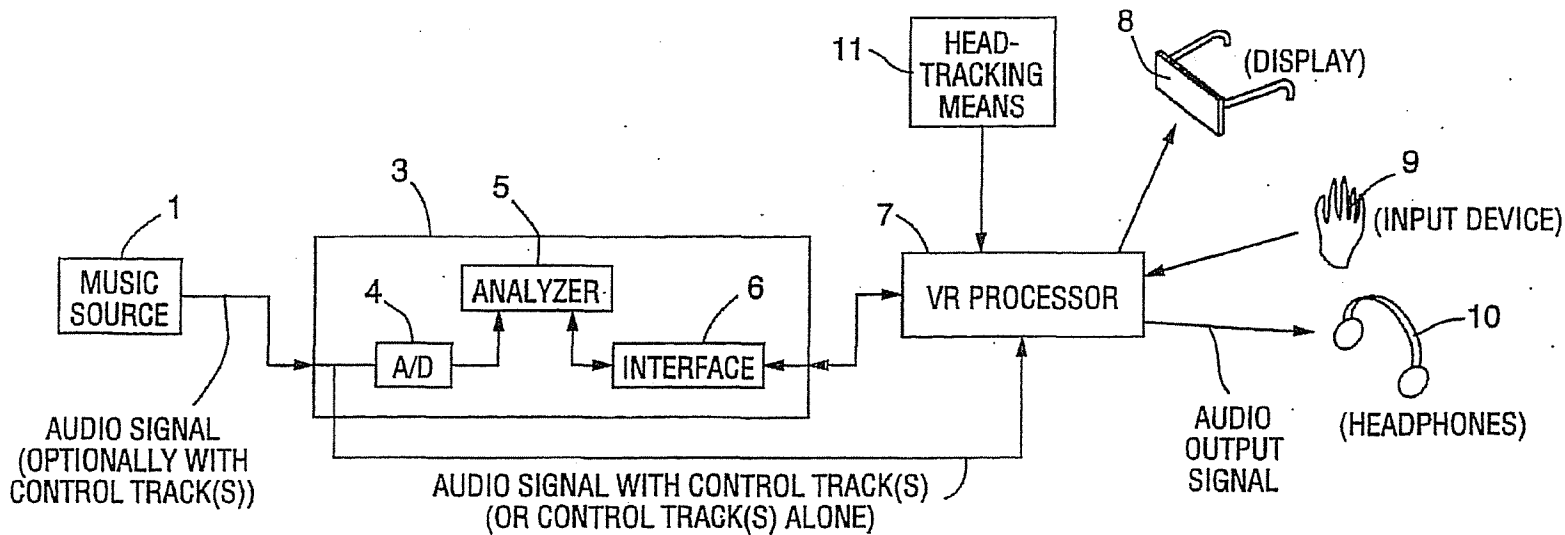

FIG. 1

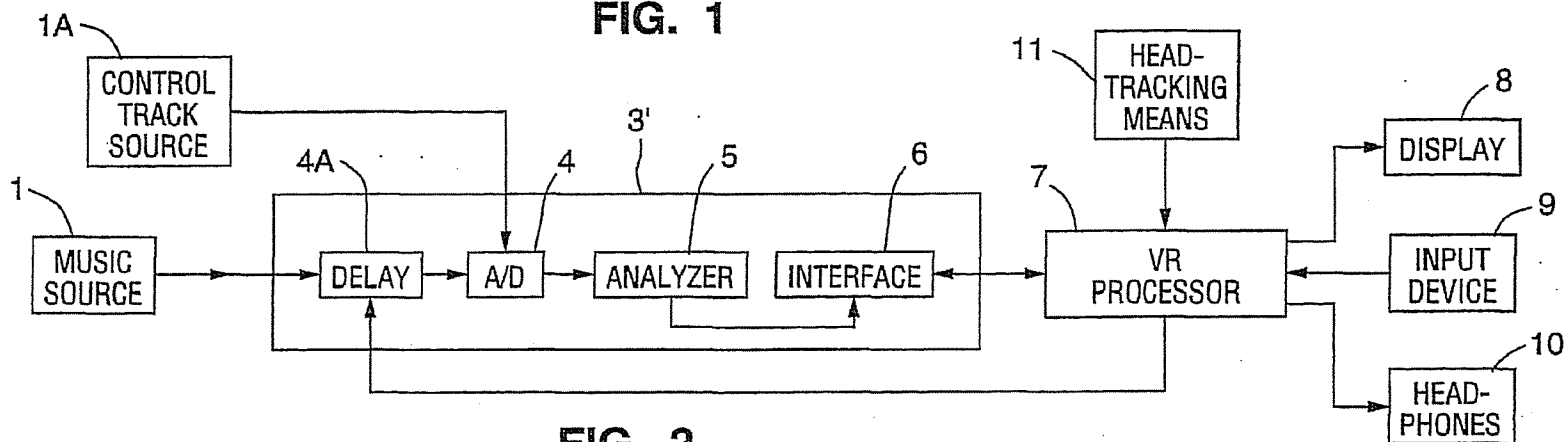

FIG. 2

U.S. Patent

Apr. 30, 1996

Sheet 1 of 7

5,513,129

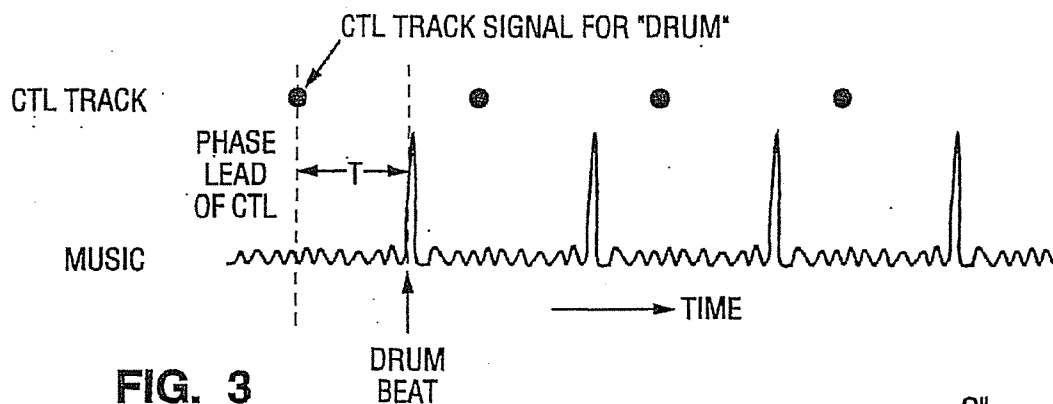

FIG. 3

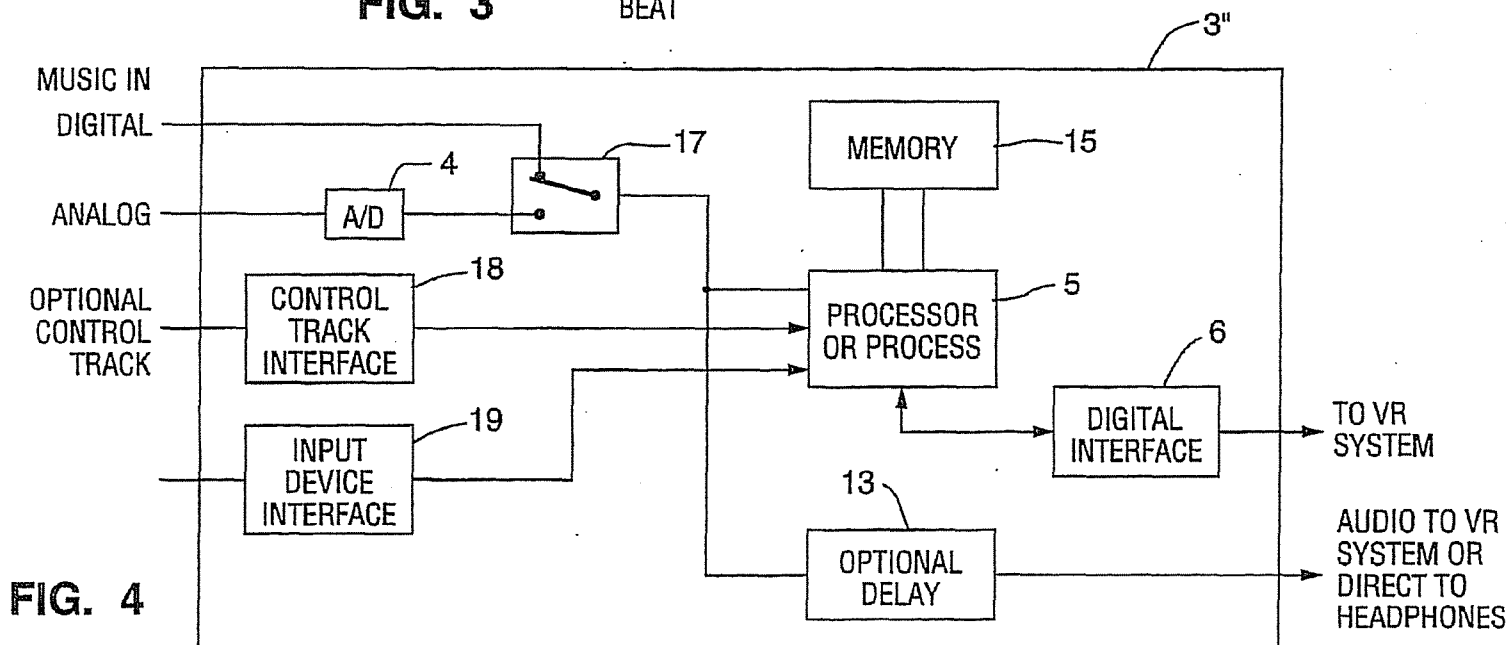

FIG. 4

U.S. Patent

Apr. 30, 1996

Sheet 2 of 7

5,513,129

U.S. Patent

Apr. 30, 1996

Sheet 3 of 7

5,513,129

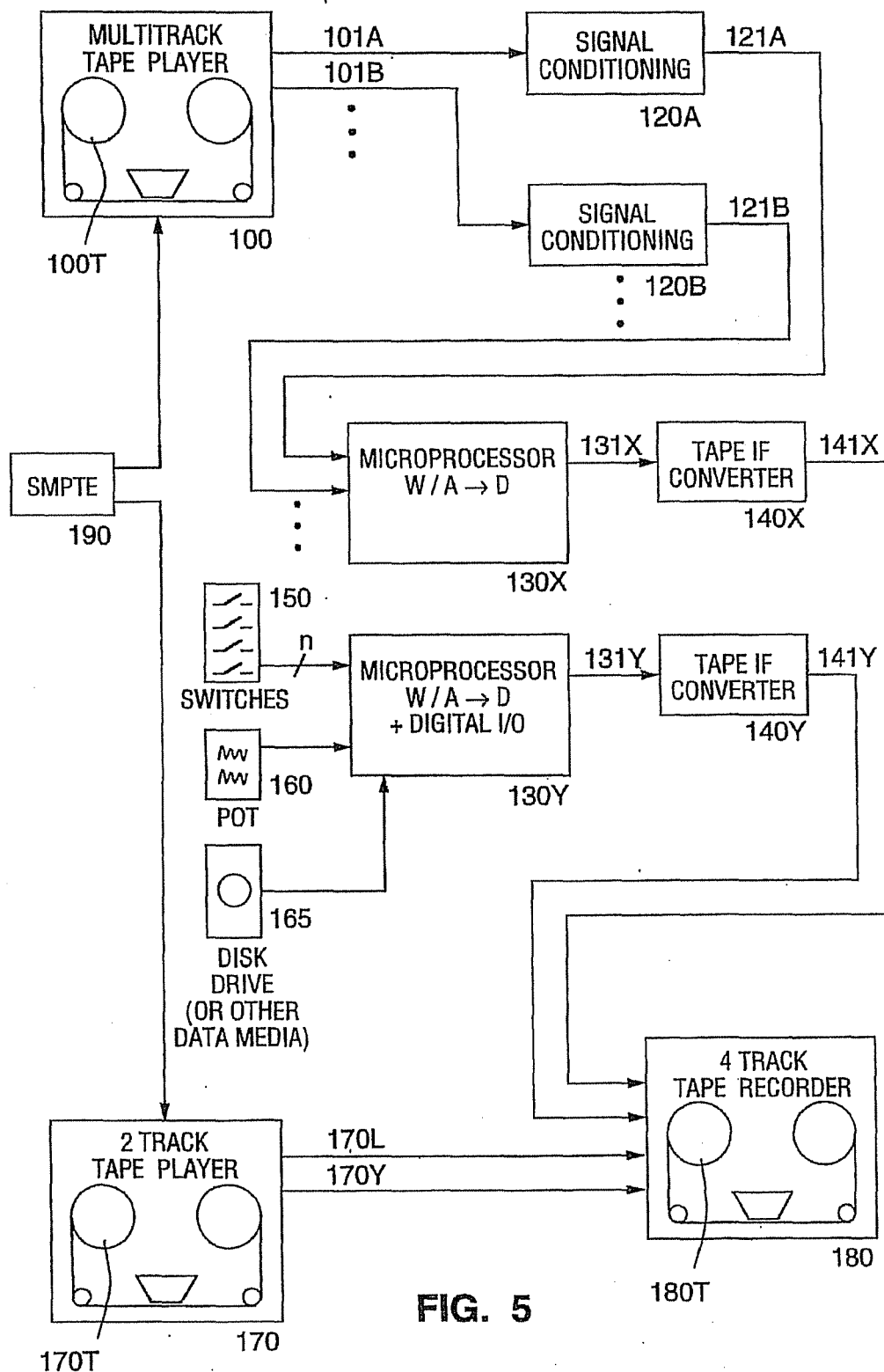

FIG. 5

U.S. Patent

Apr. 30, 1996

Sheet 4 of 7

5,513,129

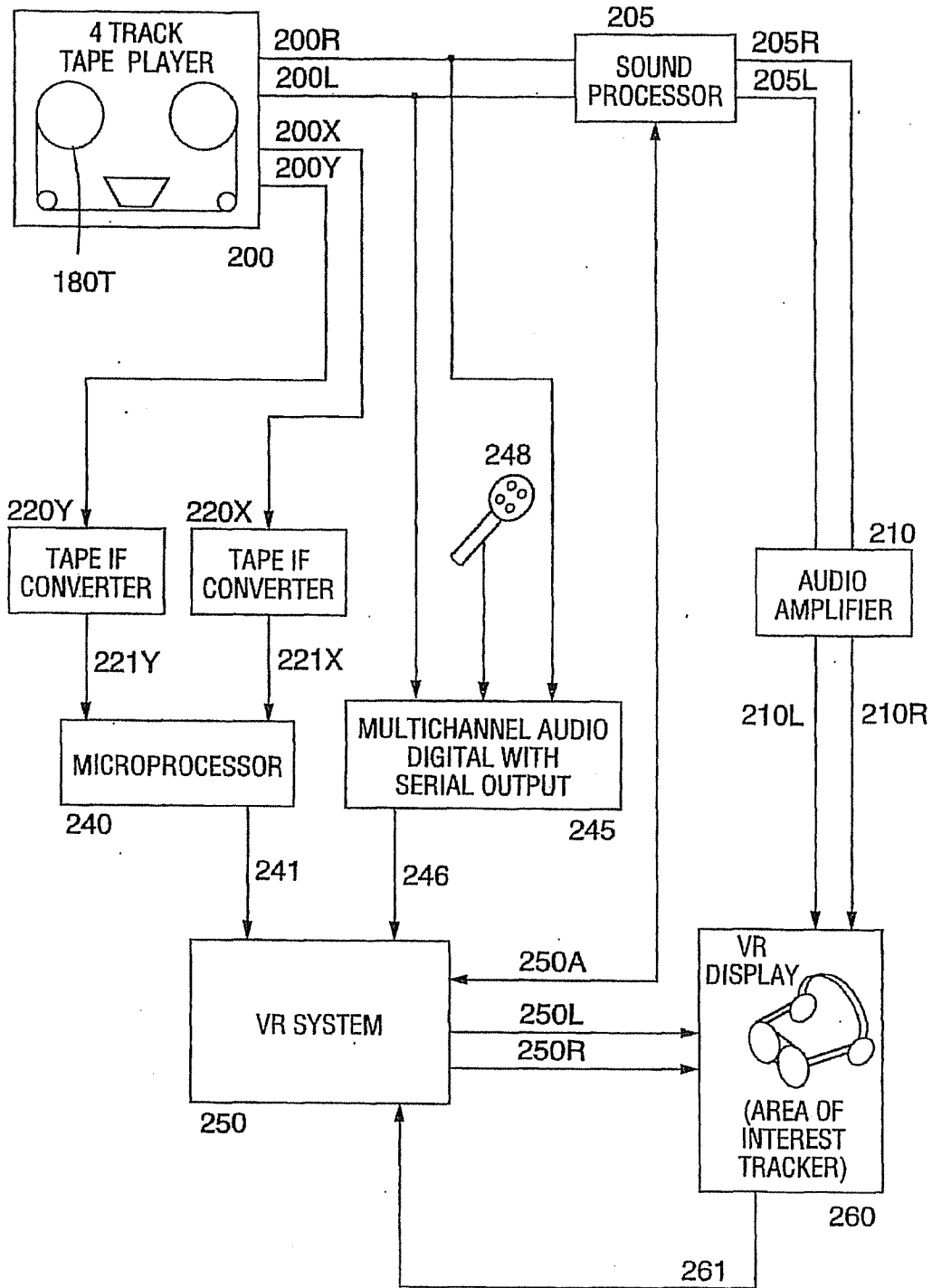

FIG. 6

U.S. Patent

Apr. 30, 1996

Sheet 5 of 7

5,513,129

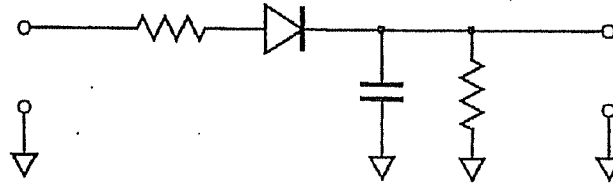

FIG. 7

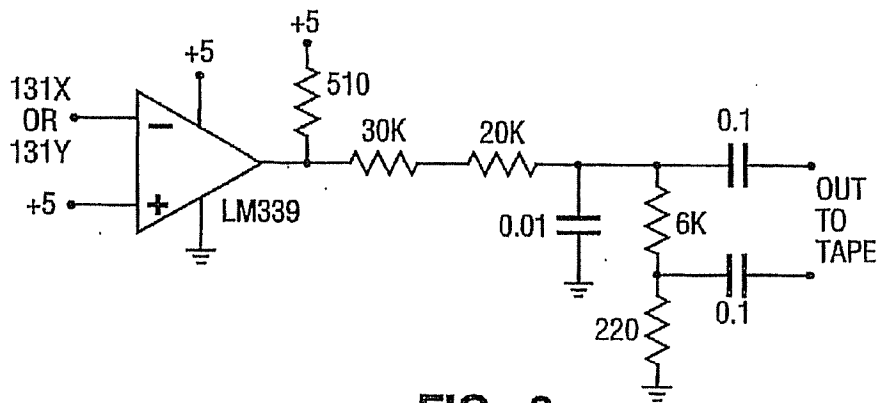

FIG. 8

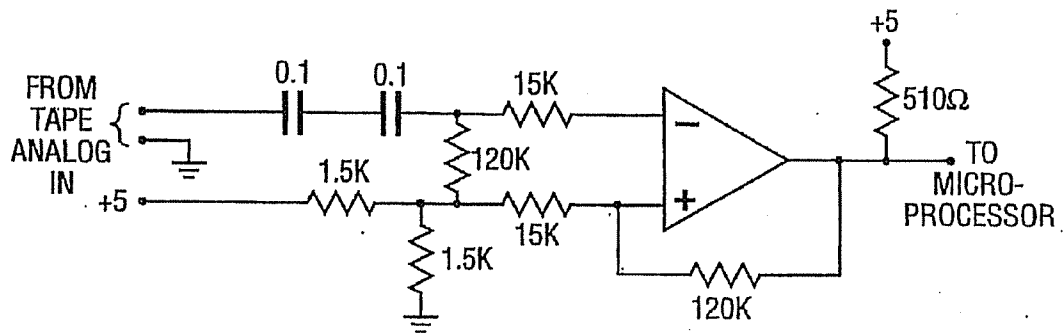

FIG. 9

U.S. Patent

Apr. 30, 1996

Sheet 6 of 7

5,513,129

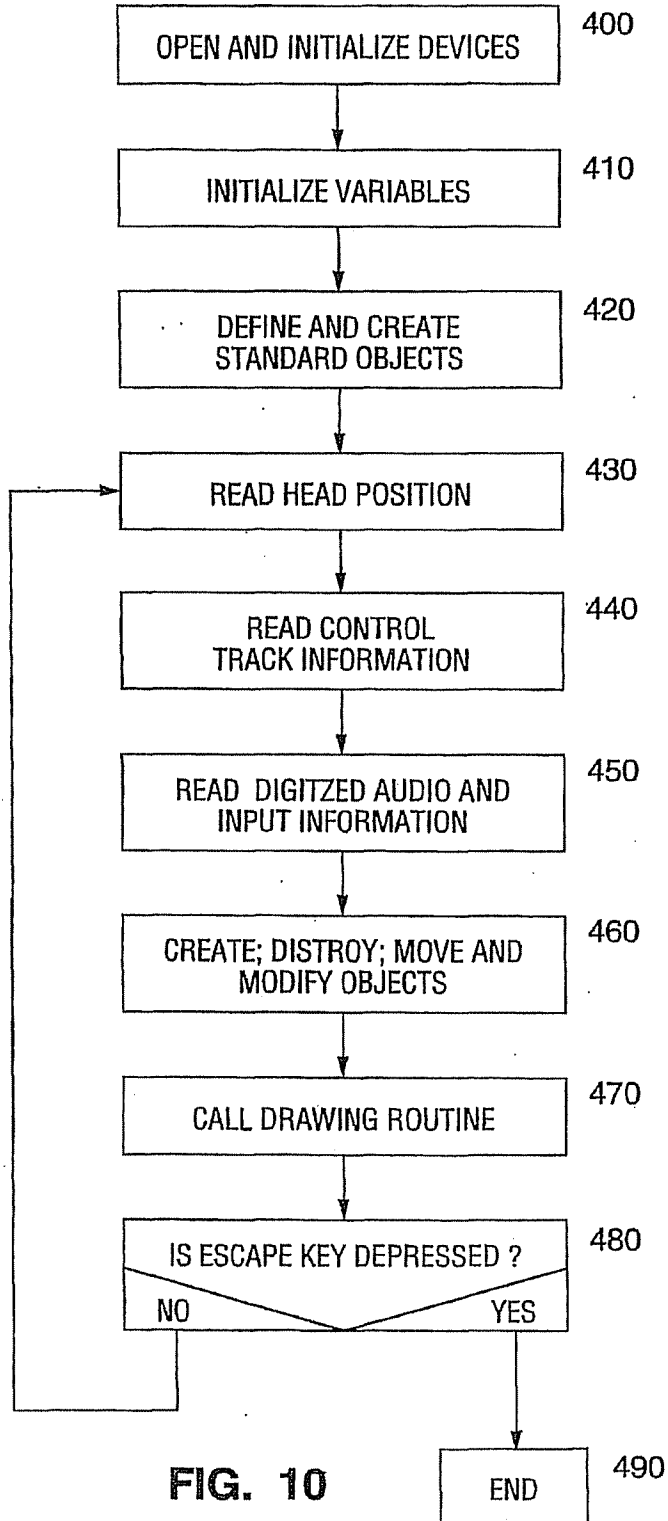

FIG. 10

U.S. Patent

Apr. 30, 1996

Sheet 7 of 7

5,513,129

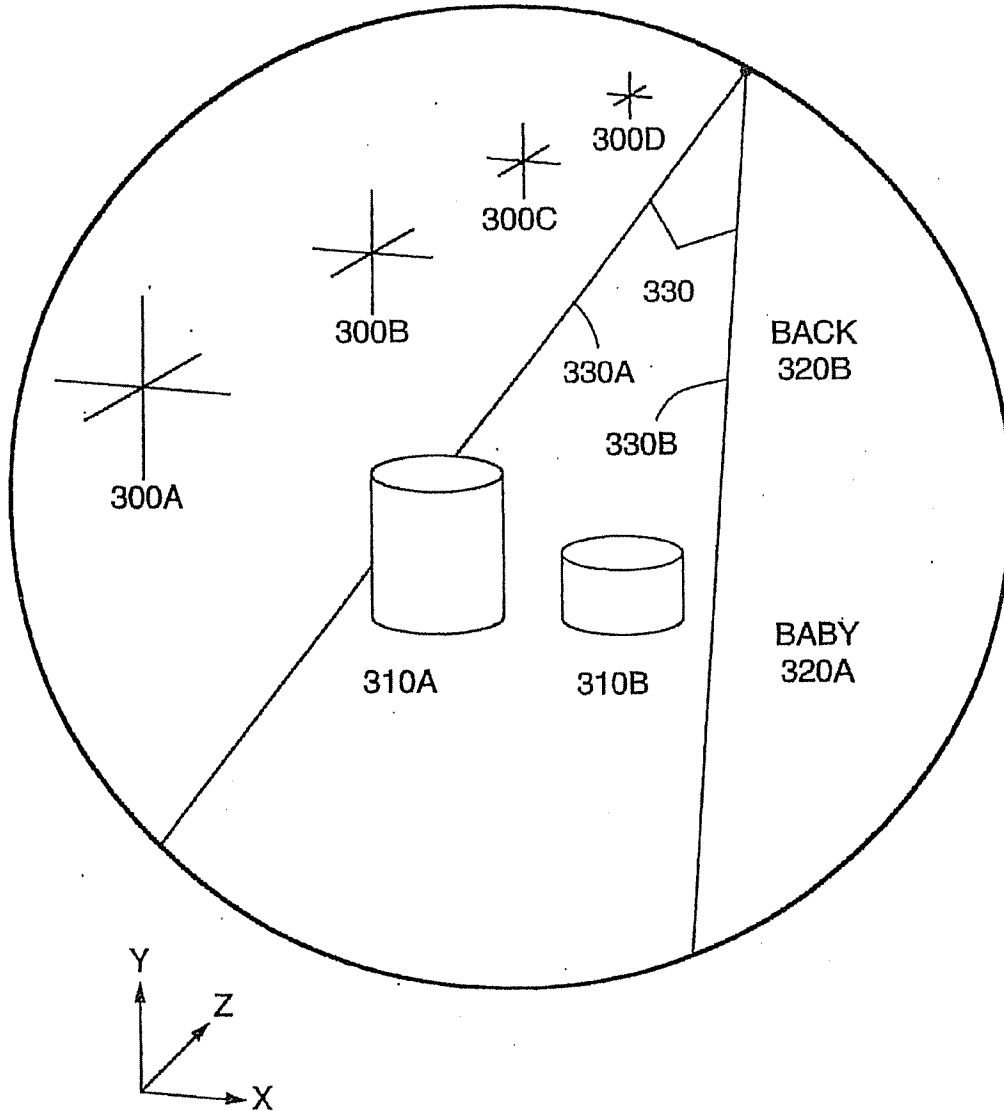

FIG. 11

5,513,129

1

**METHOD AND SYSTEM FOR
CONTROLLING COMPUTER-GENERATED
VIRTUAL ENVIRONMENT IN RESPONSE
TO AUDIO SIGNALS**

Field of the Invention

The invention pertains to methods and apparatus for controlling a computer system in response to music signals, or in response to prerecorded control tracks corresponding to audio signals (such as music signals). In preferred embodiments, invention pertains to methods and apparatus for creating and modifying, or otherwise controlling, computer-generated virtual environments (or displayed virtual objects in virtual environments) in response to music signals or in response to prerecorded control tracks corresponding to audio signals.

BACKGROUND OF THE INVENTION

The terms "virtual environment," "virtual world," and "virtual reality" are used interchangeably to describe a computer-simulated environment (intended to be immersive) which includes a graphic display (from a user's first person perspective, in a form intended to be immersive to the user), and optionally also sounds which simulate environmental sounds. The abbreviation "VR" will sometimes be used herein to denote "virtual reality," "virtual environment," or "virtual world". A computer system programmed with software, and including peripheral devices, for producing a virtual environment will sometimes be referred to herein as a VR system or VR processor.

The graphic display generated by a VR system can be a two-dimensional (2D) or a three-dimensional (3D) display. Typically, a VR system includes an input device and user interface software which enable a user to interact with the scene being displayed, typically to simulate motion in the virtual environment or manipulation of displayed representations of objects ("virtual objects") in the virtual environment. Typically, the illusion of immersion in a virtual reality system is strengthened by the use of head-tracking or some other such system which directs the computer to generate images along the area of viewing interest of the user.

The present invention is a method and apparatus particularly useful for creating and/or controlling virtual environments. A VR system which embodies the invention can rapidly and inexpensively create, animate, or otherwise control a wide variety of entertaining virtual environments and virtual objects in response to music or in response to prerecorded "control tracks" which correspond to audio signals (such as music).

While currently being used in the research and scientific communities, VR systems are becoming less expensive and are poised to reach the consumer electronics market as entertainment devices.

VR systems must generate a much greater amount of content data (image data and audio data simulating environmental appearance and sounds) than must be generated in most other electronic media. Whereas video game systems require complex scenes to be generated and themes to be programmed, such systems can easily limit the scope of the game content because they can easily constrain the player to move in a few simple directions (e.g., left and right) and need only produce images to be presented on flat screen monitors or on simple 3D field-sequential type monitors.

2

In contrast, by their very nature, VR systems allow the user to look around and fly around in many different directions and positions. Even where the user is constrained to look only toward the left or the right, VR systems must construct complete representations of 3D worlds. This complexity has made it very difficult to generate virtual worlds for the consumer entertainment market in a quick fashion.

In addition to the complexity of creating static 3D models for virtual worlds, it has also been difficult to control the dynamics of virtual worlds. VR systems to date are notorious for providing only very boring and nearly static environments. The few VR systems that include dynamic motions of the virtual world either base such motions on physical laws (such as gravity) or base the motions on corresponding motions produced by human users (such as motion of the fingers of a user wearing a conventional "glove" input device).

The present invention overcomes the limitations of conventional VR systems by providing an efficient way to generate content data (i.e., animated image data and audio data) to fill or populate a virtual environment in a choreographed response to input music signals.

There has long been an interest in the virtual reality field with respect to the possibility of virtual musical instruments and the creation of new and novel instruments within a virtual world. The present invention is a radical shift from previous attempts to combine music and virtual environments.

Conventional efforts to integrate music with virtual environments have, to date, all been directed toward creation of music from a virtual environment. The musical expression of the user has been treated as an urge seeking to be brought forth, and virtual environments have been seen as vehicles for the user to perform music or dance without having to learn special physical skills. Much effort has been made to make sounds appear to be coming from virtual objects in the virtual environment. This has been done by running audio into the VR system and then convolving the audio in such a way as to make it appear to come from a certain place in the virtual environment.

For example, at the NASA Ames View Lab, Scott Fisher, Rick Jacoby, and others explored virtual environments. One aspect of the research was the integration of audio into the virtual experience. This included the use of audio cues for such purposes as telling one if one bumped into a virtual object, but there was no tactile feedback for such events. The research pushed into the more artistic realm of creation of music in the context of a virtual world.

Mark Bolas and Phil Stone created the Virtual Theremin and virtual drum kit. In this system, the user wore a glove and a hand tracker and moved the gloved hand to manipulate virtual objects which were in turn linked to various synthesizer parameters. Thus, by manipulating virtual objects (as taught, for example, by U.S. Pat. 4,988,981, issued Jan. 29, 1991), sounds of different qualities could be created. A skilled user could create modern sounding musical interludes. These ideas have been carried forth by people such as Jaron Lanier who has given a number of public performances in which he manipulates virtual objects to create a musical performance. Research and exploration along these lines is expected to continue (the virtual "air guitar" and the like will probably be developed). In all VR systems of this type, manipulation of a virtual object causes the sound or music to change.

Currently, virtual worlds are created by describing a simulation and a number of objects. The interaction of the

5,513,129

3

objects is described in some form of simulation language or graphical description. Traditionally, the control and creation of the objects is driven by "world building" software. Once a virtual world has been created, a limited number of its parameters may be manipulated by the user from "inside" the virtual world. One example of how these databases are created is described in PCT International Patent Application WO 92/09948, by VPL Research Inc. As is evident from WO 92/09948, it has define animation for all or even some of the virtual objects in a virtual world. Until the present invention, it had not been proposed to interface to nodes in a database defining a virtual environment, and to manipulate such nodes, on the basis of music.

Conventional VR systems and music have thusfar been used together in ways which have the following disadvantages:

- (a) a VR system has been used as a virtual musical instrument, so that the user must "play" the virtual instrument (by manipulating an input device) to hear anything. This means that the system creates music, and that the system's musical output is limited by the user's ability to "play" the "instrument;"
- (b) VR systems that have given sounds to virtual objects (e.g., the system displays a virtual kitchen sink and produces a "drip-drip" sound which seems to come from the sink's location) have required that the sounds are generated by signals produced within the VR system in response to user manipulation of an input device or internal programs, which signals are then interpreted by a synthesizer. The sounds produced by the synthesizer are thus cued from the VR system in response to manipulation of an input device (which manipulation may, for example, to cause a user to "move" into a position to view or otherwise interact with a virtual kitchen sink from which sounds will then seem to emanate). Thus, these VR systems have depended on user manipulation of an input device to control the appearance or activities of objects in a virtual environment, to cause the VR system to cue production of sound events; and
- (c) VR systems have played musical scores as background music for the virtual environment.

Basically, the paradigm to date has been to create systems that have (virtual) object-driven sounds. This invention reverses the paradigm to create a system which has musically-driven objects.

One VR system has been developed in which a VR processor is programmed to perform simple operations to modify a virtual environment in response to voice commands. This VR system, developed at the NASA Ames View Lab during the years 1988-1989, was capable of displaying a virtual object, or terminating the display of a virtual object, in response to a voice command from a human user. However, the system did not produce, modify, or otherwise control a virtual environment in response to music, or in response to a prerecorded control track corresponding to an audio signal.

Outside the VR field, many attempts have been made to produce devices which provide users with visual light effects based on an audio signal, such as music. However, these systems have been disappointing to watch (principally because the light shows are two-dimensional and are not obviously correlated with the audio input), and have typically met with disappointment when marketed.

An example of a conventional apparatus for producing visual light effects based on audio signals is described in U.S. Pat. No. 4,081,829 (issued Mar. 28, 1978). This appa-

4

ratus controls the display of two-dimensional rings or solid shapes on the screen of a television receiver, in response to audio input signals. However, only a limited set of two-dimensional shapes can be displayed and only limited changes in their shape or color can be accomplished in response to the audio input.

Another example of a conventional apparatus for producing visual light effects in response to audio signals is described in U.S. Pat. No. 4,257,062 (issued Mar. 17, 1981). This apparatus controls a set of lamps which are mounted in eyewear to be worn by the user, by switching individual ones of the lamps on and off in response to music. Peak levels of specific frequency bands of the music are detected and employed to switch on or off different ones of the lamps.

Another system for producing visual effects in response to audio signals has been described in the Jan. 1993 issue of NewMedia magazine (at page 18) as a system which includes a Silicon Graphics Iris Indigo workstation, and which alters the appearance of colored visual representations of sound waves (displayed on a large screen in a concert hall) in response to crowd noise (picked up by a microphone during a concert) and live music in MIDI format (generated by musicians during the concert) supplied to the workstation.

It is believed that prerecorded control tracks (which correspond to prerecorded audio such as music) have not been employed to control operation of a computer system, such as to control generation of a virtual environment by a VR computer system. It is also believed that control signals have not been extracted from music for use in controlling generation of a virtual environment by a VR system (e.g., by populating the virtual environment with animated virtual objects which move in response to the music).

SUMMARY OF THE INVENTION

In a preferred embodiment, the invention is a computer system and computer-implemented method for the creation and control of a virtual world in response to music signals and/or prerecorded control tracks corresponding to the music signals. The system includes means for interfacing between the computer software which controls production of the virtual world, and live or prerecorded music (and/or prerecorded control tracks). The invention transcends traditional use of VR as a musical instrument, and enables a VR system to be employed as a virtual stage driven by music.

In another class of embodiments, the invention controls operation of a computer system (which need not be a VR system) in response to one or more prerecorded control tracks corresponding to audio signals, or in response to both music signals and one or more such prerecorded control tracks.

The component of the inventive system which generates control signals from input music (and/or prerecorded control tracks and/or human generated input signals), or which sends prerecorded control tracks in appropriate format to a VR system or other processor, will sometimes be referred to herein as an "Acoustic Etch" system or an "Acoustic Etch."

In preferred embodiments, the invention employs music to manipulate or control a virtual environment. This can be accomplished in several ways. Since music cannot directly interact with the virtual environment, the Acoustic Etch receives music (in some electronic, acoustic, or optical form) and generates control signals therefrom which are used by a VR system to influence activity in the virtual world.

5,513,129

5

The control signals derived from the music may be extracted from the music directly. For example, the Acoustic Etch can employ a simple algorithm (of the same type used by well-known graphic equalizers) to extract a rhythm signal indicative of the beat of some frequency band of the music (e.g. a band representing drums), or of some other parameter of a frequency band of the music. The rhythm signal is sent to the VR system which in turn generates control signals therefrom to control the rhythm of a virtual dancer (or some other moving virtual object).

As an alternative (or in addition) to extracting signals from music itself for processing by a VR system, the invention can supply to the VR system one or more prerecorded control tracks corresponding to the music, or can generate control signals from prerecorded control tracks and then supply such control signals to the VR system for processing. For example, control tracks can be prerecorded along with left and right tracks of a stereo music signal. The prerecorded control tracks, left stereo track, and right stereo track, can then be played back (simultaneously or with selected delays between them) and received in parallel by the VR system. The control tracks can be generated automatically (e.g., by electronic signal processing circuitry) in response to a music signal and then recorded, or can be generated in response to manually asserted commands from a person (while the person listens to such music signal) and then recorded.

Prerecorded control tracks can be indicative of more sophisticated analysis of a corresponding music signal than could be conveniently performed by some contemplated (e.g., inexpensive) VR system embodiments of the invention. The placement and rhythm of dancers could be encoded in prerecorded control tracks, for example.

The use of prerecorded control tracks has several advantages and features, including the following:

- (a) an entire song can be choreographed and prerecorded with a control track (for example, indicative of placement and rhythm of dancers), so that the control track forms part of the prerecorded choreographed musical work;
- (b) the control track can include higher level information, such as pictures of a dancer or other performer, which can be used as source data by the VR system to display images of the performer in the virtual environment;
- (c) the medium for the control track need not be the same as that of the music. For example, the music may be recorded on a compact disk (CD) while the control track is recorded on a computer game cartridge or other medium;
- (d) synchronization of the control track and the music can be accomplished under control of the VR system, which could use the control track to synchronize with the music, or vice versa;
- (e) the control track can be encoded (or processed) in a way which accounts for the "delay time" required for the VR system to use the information coming from the control track. This will improve the apparent synchronization between the music and the graphics data output from the VR system, even when the VR system requires a long time to "draw" a particular frame of an animated virtual world; and
- (f) a prerecorded control track can eliminate the need for some embodiments of the invention to include means for automatically decoding musical expression (the automatic decoding of musical expression is poorly understood).

6

For example, an operator can record a control track which is emotionally linked with a song. The VR system could then easily convert the control track into a variety of control signals, and can produce more repeatable and interesting results than could be achieved by processing the music directly (in the absence of the control track).

The major disadvantage of using a prerecorded control track is that the control track must be generated and recorded in advance, and then played back in some way. It must be delivered in conjunction with the music, and the easiest way to do this is on the same physical recording medium.

An advantage of embodiments of the invention which directly process music (rather than processing a prerecorded control track) is that the music and the VR control signals generated therefrom are more independent than are a control track and the VR control signals generated therefrom (and can be related in any of a variety of ways). In embodiments which directly process music, the visual experience and emotional coupling between the VR and the music is looser, since the interpretation is generically related to musical signals and their processing. However, specific processing algorithms can be used by the VR system for specific songs—thus tailoring the algorithm to the music.

In essence, preferred embodiments of the invention use music to create a "track" of distilled music which is in a form usable by a VR system. The interpretation of the information is still dependent on the VR system, or the particular VR software being run by a computer system. The same "raw" music or control track can be interpreted differently by different VR systems (or VR software programs) in the sense that different VR systems (or programs) can generate different sets of control signals in response to a single raw input signal. Alternatively, the same VR system (or program) can interpret the same "raw" music or control track differently at different times. The control track can be used to program the VR system's response and thus tailor the system to a specific song.

OBJECTS AND ADVANTAGES

Accordingly, several objects and advantages of various embodiments of the present invention are:

- to provide an apparatus which extracts information from music (or other audio) for the control and manipulation of objects within a virtual environment;
- to provide an apparatus which uses a control track prerecorded along with audio (music, in preferred embodiments) for the control and manipulation of objects within a virtual environment;
- to provide a VR system which delays audio (in response to which control signals are generated) in order to compensate for the lag introduced by other components of the VR system;
- to provide a virtual experience in which music effectively drives the display of an animated graphical scene;
- to provide a mechanism by which music is used to control and influence a virtual environment in such a way as to relieve the database which describes the virtual environment from having to define all the motions of the objects in the virtual environment;
- to provide a control track for the influence and control of a virtual environment in which the control track is created during or following the music recording and production process when individual tracks (of a multi-track musical work) that are used for a particular mix are available before being mixed down; and

5,513,129

7

to provide a control track which can contain information (such as images of a performer's face, for example) other than information extracted from corresponding music;

Further objects and advantages are to provide for the rapid creation and animation of a virtual environment from music which already has a high level of production quality.

BRIEF DESCRIPTION OF THE DRAWINGS

FIG. 1 is a diagram of a preferred embodiment of the inventive system, in which a music source is interfaced to a VR system by an Acoustic Etch system. The blocks may or may not represent physically distinct objects (several of the blocks could be implemented in a single device).

FIG. 2 is a diagram of a variation on the FIG. 1 embodiment, in which the Acoustic Etch system receives or contains prerecorded control tracks, and music corresponding to the control tracks is used to cue output of the stored control tracks to the VR processor.

FIG. 3 is a graph of a control track and a corresponding music signal, where the control track is phase shifted relative to the music signal by a degree adequate to compensate for delays that are expected to be introduced, in other parts of the system, during processing initiated in response to the control track.

FIG. 4 is a block diagram of a variation on the Acoustic Etch apparatus employed in the FIG. 1 system.

FIG. 5 is a block diagram of a system for creating an audio tape with control tracks for playback by the system shown in FIG. 6.

FIG. 6 is a block diagram of a system for playback of the audio tape produced by the FIG. 5 system.

FIG. 7 is a schematic diagram of a circuit suitable for implementing any of signal conditioning blocks 120A and 120B.

FIG. 8 is a schematic diagram of a circuit suitable for implementing either of tape IF converters 140X or 140Y (of FIG. 5).

FIG. 9 is a schematic diagram of a circuit suitable for implementing either of tape IF converters 220X or 220Y (of FIG. 6).

FIG. 10 is a block level description of the software which is preferably run on VR system 250 of FIG. 6.

FIG. 11 is a representation of a typical single eye image as displayed on display 260 of Fig. 6.

DETAILED DESCRIPTION OF THE PREFERRED EMBODIMENTS

The term "audio signal" is used herein in a broad sense to include not only sound waves but also electrical, optical, or other signals representing sound waves (such as the electrical output of a transducer in response to sound waves). The terms "music signal" and "music" are used interchangeably herein in a broad sense to include not only sound waves that are recognizable by a human listener as music, but also electrical, optical, or other signals representing such sound waves (such as the electrical output of a transducer in response to the sound waves). Typically, a system embodying the invention will receive and process music signals in the form of digitized electrical signals.

FIG. 1 is a diagram of a preferred embodiment of the inventive system. In FIG. 1, music source 1 is interfaced to VR processor 7 by Acoustic Etch system 3. VR processor 7

8

is a computer programmed with software for implementing a virtual environment. Specifically, VR processor 7 can cause image data representing a virtual environment to be displayed on display device 8 and can cause left and right channels of audio signals (simulating sounds in the virtual environment) to be played back to a user wearing headphones 10 (which include left and right speakers). Display device 8 can be any of a variety of devices, such as a device which mounts on the head of a human user (preferably including left and right monitors for providing a stereoscopic display to the user), or a single flat screen display which outputs either a non-stereoscopic display or a stereoscopic display. Head-tracking means 11 (included in both the FIG. 1 and FIG. 2 embodiments) is provided for optionally providing input (to processor 7) indicative of the position of the head of a human user wearing a head-mounted embodiment of display device 8.

Processor 7 is a computer programmed with software enabling a human user to interact with the virtual environment by manipulating input device 9, whose output is supplied to processor 7. In one embodiment, input device 9 includes a glove and sensors mounted to the glove for detecting movements of a user's hand within the glove. In another embodiment, input device 9 includes a frame and sensors for producing output signals indicative of forces or torques exerted on the frame by a user. The frame is preferably mounted to display device 8 (or to a base supporting the display device) symmetrically with respect to an axis of symmetry the display device, with limited freedom to move relative thereto, and the sensors are preferably mounted at the ends of the limited range of motion of the frame.

An analog-to-digital conversion circuit within Acoustic Etch unit 3 receives and digitizes a music signal from source 1. The music signal is optionally accompanied by one or more prerecorded control tracks corresponding to the music signal, which control tracks are played back with the music signal. Analyzer 5 within Acoustic Etch unit 3 receives the digitized output of circuit 4, and generates control signals by processing the music signal (or both the music signal and the control tracks). The control signals output from analyzer 5 are supplied through interface 6 to VR processor 7, for use within processor 7 for controlling generation of the virtual environment. One or more of the control tracks (or both the music signal and one or more control tracks, or the music signal alone) can be supplied directly to VR processor 7, to enable processor 7 to cause headphones 10 to play the music signals, and to control generation of the virtual environment in response to the control tracks or music, such as if the functions of the Acoustic Etch unit are embodied in the VR processor.

In the FIG. 1 system, the control track is optionally prerecorded on the same medium as the music signal corresponding thereto. Acoustic Etch unit 3 can, in effect, extract the control track from the medium and pass it (or a control signal generated therefrom) to VR processor 7.

FIG. 2 shows a variation on the system of Fig. 1 in which a control track and a corresponding music signal are recorded on (and played back from) different media (one from source 1A; the other from source 1).

For example, the control track can be recorded on, and played back from, a cartridge (1A) for a video game machine and the music can be recorded on, and played back from, a CD (1). The cartridge could be synchronized to the CD either by an electrical or other connection, or by the user, or by means used by the audio industry such as the SMPTE

5,513,129

9

standard. This is a simple approach in the sense that the control track can be created (and prerecorded) in advance by a user listening to the same music.

Then, the CD can be played again and synchronized with the recorded control track to trigger processing of the recorded control track in the Acoustic Etch unit (without the need to re-record the CD with control track information). Note that the cartridge can be part of a separate unit that is interfaced to the Acoustic Etch, or it can be part of the Acoustic Etch.

It may be desirable to delay the music which is heard by the user with respect to the control track and/or the music used for analysis by the Acoustic Etch. In this manner, system delays can be compensated for, and better causality between music and visual images produced by the VR system can be achieved.

The Acoustic Etch can set and control parameters in the VR processor, and the VR processor can set and control parameters in the Acoustic Etch. For example, VR processor 7 can set the delay time for which the music is delayed in circuit 4A (or such delay time can otherwise be set) to compensate for the delay time required for processor 7 to process control signals produced from the control tracks or control signals generated from the analyzed music (such as by changing a displayed virtual object in response to one such control signal). The delayed music from circuit 4A and the control tracks from source 1A are processed in elements 4-7 in the same manner as non-delayed music and control tracks are processed in corresponding elements 4-7 of FIG. 1. Thus, in the FIG. 2 embodiment, the delay introduced by delay circuit 4A can be set so that VR processor 7 receives a segment of the music signal at precisely the time it completes the processing of control data from a portion of the control track corresponding to such segment of the music signal. In FIG. 1, the advantages of delaying the musical source can be achieved by either recording the control track earlier in time on the music source medium, or by delaying the music signal within the Acoustic Etch unit or the VR processor or by a separate audio delay box.

In the upper graph of FIG. 3, each dot represents a pulse of a control track. The lower graph of FIG. 3 represents a delayed version of a music signal produced by a drum and corresponding to this control track (in the lower graph, vertical displacement represents amplitude of the drum beat and the horizontal axis represents time). Each pulse of the control track corresponds to a peak amplitude of the music signal. However, the music signal of FIG. 3 has been delayed (phase shifted) by a delay period T (such as by remaining in delay circuit 4A) chosen to compensate for processing delays that are expected to be introduced in other parts of the inventive system (such as the VR processor) in order to accomplish processing initiated in response to the control track (or control signals generated from the control track, or control signals generated from analyzed music).

FIG. 4 is a block diagram of a variation (Acoustic Etch unit 3") of Acoustic Etch unit 3 which is employed in the FIG. 1 system. FIG. 4 implements an optional method for compensating for the delay introduced by the analysis of the control track or the music and the manipulation of the virtual environment. Acoustic Etch unit 3" of FIG. 4 can receive digital prerecorded music and/or control track or analog prerecorded music and/or control track. Each such analog signal is digitized in A-to-D converter 4 and then supplied to one input of switch 17. The other input of switch 17 receives the digital music signals. Switch 17 is controlled to select one of the two inputs, and is connected so as to supply the

10

selected signal to processor 5 (which can implement computer software stored in memory 15).

Delay circuit 13 can be operated to delay the music signal corresponding to the control track(s) to enable activity in the virtual world to appear to be synchronized or even non-causal. This is important because the delay between hearing an event (such as through headphones 10) and seeing action as a result (on display device 8) is disconcerting. In the real world one usually sees the event then hears the sound. In the virtual case (without delay circuit 13), one would hear sound (e.g., thunder) and then VR processor 7 would draw a corresponding visual event (e.g., lightning) so that user would see the visual event a fraction of a second later. This is the exact opposite of what one is used to in the real world where one sees an event and then hears the result. The amount of delay implemented by circuit 13 will typically need to be constant or shifted during a silent period or the user will perceive the pitch of the sounds (e.g., heard through headphones 10) as having changed as the amount of delay is adjusted.

With reference again to FIG. 3, in a variation on the scheme implemented by delay unit 4A (of Fig. 2) or delay circuit 13 of FIG. 4) instead of delaying the music, a pre-selected delay between music and control tracks is implemented at the time when both the control tracks and the music are prerecorded. The control track is, in effect, phase shifted in advance to account for lags expected to be introduced by the analysis (i.e., the time required by analyzer 5 of FIG. 2 to generate control signals from music) and/or by VR graphics system 7. The advantage of implementing this phase shifting when prerecording the control track(s) is that it minimizes the hardware required to implement the Acoustic Etch unit. There is also no need to delay the music, which could be expensive.

To summarize, because there is inherently a finite amount of time between the receipt of control track or digitized audio information and the time a VR system can cause a change in its visual output in response to the received information, preferred embodiments of the invention will implement one of two delay compensation techniques. One of the techniques is to shift the control tracks in time relative to the audio information (musical tracks). For example, if the control tracks are shifted by 10 milliseconds (e.g., if the control tracks are played back with a lead time of 10 milliseconds prior to the corresponding audio), then the VR system would have 10 milliseconds in which to create and display the objects (and then simultaneously display the objects and play the corresponding audio). By accounting for the delay time in this way, virtual objects can be displayed very closely in time with corresponding music with little noticeable time difference, or even a reversed time difference.

The second one of the delay compensation techniques is to delay the music that is being played (relative to the prerecorded control track which is also being played back). This can be done in a variety of ways including but not limited to the use of a digital delay box between the music source (e.g., tape player 200 shown in FIG. 6, described below) track and an amplifier which receives the music from the source (e.g., amplifier 210 of FIG. 6). Alternatively, the music can be delayed, and then replayed and processed, by a digital VR computer itself (e.g., VR system 250 of FIG. 6), if the VR computer has digital-to-analog audio capabilities (e.g., means for converting the replayed digital audio into analog signals such as signals 250L and 250R of FIG. 6 for transmission to headphones worn by the user).

With reference again to FIG. 4, unit 3" typically extracts control information from the input music or control track(s)

5,513,129

11

or both. Processor 5 and memory 15 and optionally also associated peripheral hardware (not shown) implement the extraction of the control information from a control track and/or from the music itself. The FIG. 4 system includes both a digital and an analog input port for the input audio. In a consumer product, only one of these would be used and the other left out for cost savings. Since most music is stereo, usually there would in fact be two (left and right) channels of audio output from switch 17 although probably only one processor 5 for receiving and processing both channels. Control track interface 18 of unit 3 receives one or more prerecorded control tracks and converts them (if necessary) into form for processing by processor 5. Input device interface 19 receives input signals, generated in response to user manipulation of an input device, and converts them (if necessary) into form for processing by processor 5 (processor 5 can then generate control signals therefrom).

An important advantage of the FIG. 4 embodiment is in its flexibility to modify and expand the capabilities of the algorithms implemented by processor 5.

In operation, the FIG. 4 device takes in music and processor 5 processes it to produce control information. The control information is then passed on to the VR computer which is actually rendering the virtual environment. Although in FIG. 4, delay element 13 is within Acoustic Etch unit 3, it could alternatively be physically located in the VR computer system itself, or external to both.

One embodiment of the internal algorithms that can be implemented by processor 5 (which is sometimes referred to herein as "analyzer" 5) of Acoustic Etch unit 3 are those related to simple filtering and analysis. In this case, means are provided (for example within processor 5) for filtering the incoming music, so that processor 5 can analyze the music in terms of its spectral components. By examining the level of a particular frequency range processor 5 can make a determination as to the rhythm or beat of the music. The beat of the music is passed on to the VR system which can then perform operations such as displaying virtual hands clapping in time to the beat of the music. The overall level of the music could be used to determine how many pairs of clapping hands there are at any particular time. As the music rises and falls in overall level, the VR processor could create and destroy virtual objects.

When the Acoustic Etch unit is used in conjunction with a control track, the potential complexity and richness of the virtual environment is enhanced. Processor 5 of Acoustic Etch unit 3 could extract the control track from either the music media or process a prerecorded control track from a separate source. Processing of a control track (or a control signal generated therefrom, rather than from a corresponding music signal) within the VR processor is more powerful than analysis of music in the Acoustic Etch followed by processing of the resulting control signal in the VR processor, because it does not have to be quickly determined and enables the VR processor to respond to control track information not present in the music. At the start of or before the start of the song, for example, the control track could contain compressed images of the performers. As the song is played, the control track is processed by the Acoustic Etch unit which instructs the VR system to show the images of the performers texture mapped onto dancing characters which dance in time to the music. Note that the Acoustic Etch unit could be incorporated as part of another device, e.g., the player of the input music signal or the prerecorded control tracks or the VR system. One can imagine the integration of an Acoustic Etch unit into a cartridge for a video game machine with CD capability, for example. A program in the

12

cartridge and a track on the CD would be employed or both could be contained on the CD. In addition to minimizing the cables, this is also cost effective.

The audio can bypass the VR system and go directly to headphones 10, however, note that in FIGS. 1 and 2, the music is passed through VR processor 7 rather than directly into the headphones 10. In this way the VR processor may convolve the sound in such a way as to create the illusion of having it coming from a particular location in the virtual environment.

In summary, the invention is a novel way of interfacing music to VR. The inventive apparatus stands in contrast to traditional approaches which have tried to interface VR to music. The inventive apparatus allows for the highly produced and refined qualities of music to be expressed in a virtual environment.

There are several exciting possibilities with this apparatus and method. In the case of an Acoustic Etch unit which analyses music and controls a virtual environment of a dancer dancing, one could play any musical piece and the Acoustic Etch would extract the low frequency beat which would tell the VR system when to have the dancer step. Thus, one could watch a displayed (virtual) stick figure dancing in time. By using the delay mechanism disclosed, the virtual dancer and the music would occur far more synchronously than if the music was not delayed.

System cost may be reduced by incorporating the delay in the music player itself. Many current digital units employ a delay for error correction.

Employing the control track method with the Acoustic Etch unit allows one to create more advanced choreographs and minimizes cost as the processing requirements would be much less.

The invention may also lead to new ways to analyze real time data streams in order to look for patterns and interesting sequences.

Next, a more detailed description of a preferred implementation of the invention will be provided, with reference to FIGS. 5 and 6. FIG. 5 is a diagram of a system for creating an audio tape with control tracks, for use in the playback system shown in FIG. 6.

FIG. 5 shows Multitrack Tape Playback Unit 100, Multitrack Master Audio Tape 100T, Single channel audio signal 101A (output from 100), additional "n" Single channel audio signals 101B output from 100, Audio Signal Conditioning circuit 120A, additional "n" Audio Signal Conditioning circuits 120B, Analog Data Signal 121A, additional "n" Analog Data Signals 121B, Microprocessor Unit 130X with an "n" channel analog to digital converter, Serial Data Stream 131X, Tape interface (IF) Converter 140X, Audio Quality Data Signal 141X, switches (or other Digital Data Input Devices) 150, Analog Data Input Devices 160, Data Storage and Input Device 165, Microprocessor Unit 130Y (including digital input and multiple channel analog to digital converter), Audio Quality Data Signal 131Y, Tape IF Converter 140Y, Audio Quality Data Signal 141Y, Two-Track Audio Tape Playback Unit 170, Two-Track Master Tape 170T, Left Channel Audio Signal 170L, Right Channel Audio Signal 170R, 4-Track Audio Tape Recorder 180, 4-Track Audio and Virtual Control Track Tape 180T, and SMPTE Synchronizer 190.

FIG. 6 shows 4-Track Audio and Virtual Control Track Tape 180T, 4-Track Tape Player 200, Right Channel Audio Signal 200R, Left Channel Audio Signal 200L, X-Channel control signal 200X, Y-Channel control signal 200Y, sound processor 205, 2-Channel Audio Amplifier 210, audio sig-

5,513,129

13

nals 205R, 205L, 210R, and 210L, Tape IF Converter 220X, Tape IF Converter 220Y, Microprocessor Unit with two-channel analog to digital converter 240, Serial Data Stream 241, serial data stream 250A, multi-channel Analog-to-Digital Converter 245 with serial data output, Serial Data Stream 246, Microphone 248, Virtual Reality Graphics System 250, Left Eye Video Signal 250L, Right Eye Video Signal 250R, Virtual Reality Audio and Visual Display Unit 260 (with Headtracking means), and Head Tracking Signal 261.

With reference to FIG. 5, multitrack tape player unit 100 is of the type typically found in audio recording studios. Unit 100 is loaded with a multitrack master tape 100T and outputs multiple channels of audio (typically music) signals 101A, 101B, and so on.

These signals are fed to signal conditioners 120A, 120B and so on, via standard audio patch cords. Each of the signal conditioners consists of electronic circuitry, and each outputs an analog control signal (121A or 121B) which is fed to one of the analog input pins of microprocessor unit 130X. Microprocessor 130X can be, for example, a M68HC11EVBU Universal Evaluation Board made by the Motorola Company, and is programmed with software for generating a control track from the conditioned audio data that it receives, and outputting a serial data stream to tape IF converter 140X. Tape IF converter 140X is comprised of electronic circuitry and outputs a data signal 141X (indicative of the control track) of the type that can be stored on standard audio magnetic tape. This signal is fed to 4-track audio tape recording unit 180 that is loaded with a 4-track audio cassette tape 180T.

An assembly of switches (or other means by which a human operator can input digital signals) 150 feeds parallel digital data to microprocessor 130Y (which can be identical to or similar in type to microprocessor 130X). Also connected to microprocessor Unit 130Y are analog input devices 160 (such as a "multiple degree of freedom" joystick or other input device), and a data storage device 165. Device 165 can be a magnetic disk drive or other data storage and retrieval device (or alternatively, a data entry device). Microprocessor Unit 130Y is programmed with software for generating a control track in response to the input data it receives, and outputs a serial data stream to a tape IF converter 140Y. Tape IF converter 140Y is comprised of electronic circuitry and outputs a data signal 141Y (indicative of the control track) of the type that can be stored on standard audio magnetic tape. This signal is fed to four-track audio tape recording unit 180.

A two-track tape playing unit 170 is loaded with a two track mixed down master tape 170T and is time synchronized with the multitrack unit 100 via SMPTE synchronizer 190 or other such device. The two-track tape player 170 outputs a left audio signal 170L and a right audio signal 170R that are input to the 4 track tape recorder 180. Recorded cassette tape 180T thus has two tracks containing audio signals 170L and 170R (which are typically music signals), and two other tracks containing control tracks corresponding to the audio signals.

FIG. 6 represents the system used to play back and experience the audio tape 180T (which has control tracks). A four-track audio tape player 200 outputs four audio signals: left and right audio signals 200R and 200L, and control track signals 200X and 200Y consisting of data encoded as audio signals. Signals 200X and 200Y are input to two tape IF converters 220Y and 220X which extract serial data streams 221Y and 221X therefrom, which

14

streams are input to a microprocessor unit 240 of a type identical (or similar) to microprocessor unit 130X. Microprocessor unit 240 is programmed with software for generating control signals for VR graphics system 250 in response to one or both of data streams 221Y and 221X, and outputs a serial data stream indicative of such control signals to virtual reality (VR) graphics system 250, which can be, for example, a Silicon Graphics Crimson Computer with Reality Engine graphics, serial port board, and VLIB software available from Pakespace, Inc. (of Menlo Park, Calif.).

VR system 250 outputs two video signals 250L and 250R representing the left and right eye viewpoints of a virtual environment to head-coupled display unit 260.

Audio signals 200R and 200L are input to a sound processor 205, for example, a Convolutron sound spatializer available from Crystal River Engineering (of Groveland, Calif.) or other sound processing equipment which feeds the processed sound signals 205R and 205L to an audio amplifier 210 which feeds two amplified audio signals 210R and 210L to head-coupled display unit 260. The audio signals 200R and 200L, and input from a microphone 248 are also input to multichannel audio digitizer 245 which outputs a serial data stream 246 to VR system 250.

Virtual reality system 250 also receives head position or other area of interest information from head-coupled display 260.

FIG. 7 is a schematic diagram of a circuit fragment suitable for implementing any of signal conditioning blocks 120A and 120B. It consists of four electronic components.

FIG. 8 is a schematic diagram of a circuit fragment suitable for implementing either of tape IF converters 140X or 140Y. It consists of various electronic components.

FIG. 9 is a schematic diagram of a circuit fragment suitable for implementing either of tape IF converters 220X or 220Y. It consists of various electronic components.

FIG. 10 is a block level description of the software which is preferably run on VR system 250 of FIG. 6.

FIG. 11 represents a typical single eye image as displayed on the display 260. Images are virtual objects. Objects 300A, 300B, 300C, and 300D are objects comprised of three orthogonal lines of the same size that are positioned at the same x and y location, but recede backwards from the user along the z axis over time. Objects 310A and 310B are fixed in space, but change height over time. Lines 330 (including lines 330A and 330B) are fixed in space and remain stationary over time. Words BABY 320A and BACK 320B are fixed along the XY plane and have no depth in along the Z axis.

In operation, the systems of FIG. 5 and 6 can implement the following embodiment of the invention. The overall process can be broken into two halves: the recording of the medium and the playback. Figure 5 represents the recording phase while FIG. 6 represents the playback phase.

In FIG. 5, a multitrack tape playing unit 100 is of the type typically found in professional recording studios. It is loaded with the master tape 100T that recorded the raw and unmixed audio efforts of artists recording a song. In the typical production of recorded music products, this tape is later mixed and processed to produce a two-track master tape 170T which is later mass produced for the consumer market. The multitrack master tape 100T and the two track master tape 170T are playing at the same time in synchronization with each other through the use of a standard commercially available time synchronization unit, for example SMPTE synchronizer 190 that works in conjunction with the tape playing units 100 and 170.

5,513,129

15

In this embodiment, the 2-track audio signals 170L and 170R are recorded on 4-track tape 180T via a standard four track tape recording unit 180. This unit can be a consumer type 4-track cassette tape unit, or a high quality professional tape recorder that will produce a master tape for acoustic etch type tapes. The audio signals 170L and 170R represent the original audio content of a commercial tape and are not typically processed further. That is to say that two tracks of four-track tape 180T are the music that the user of the tape would expect to hear without the Acoustic Etch device of the invention. However, it may be desired to delay the music in time with respect to the control tracks.

The other two tracks that are recorded from signals 141X and 141Y are the control tracks that are derived as shown in FIG. 5 and will be used during playback to create and control and manipulate the virtual environment that a user experiences while listening to the original audio signals.

While there are a multitude of ways to create these control tracks, this embodiment generates such tracks in either (or both) of two ways. The first way automatically derives control signals from original multitrack master tape 100T and the second way allows a human operator to create control signals via input means 150 and 160 and a computer data storage device 165.

To create the control track in the first way, the "n" multiple audio output channels 101A, 101B and so on, which represent each audio channel on the original multitrack tape 100T are fed into signal conditioning blocks 120A and 120B. These blocks serve to distill the audio information on each track into a lower frequency signal that will serve as an aesthetically valuable control variable in the virtual environment. In the preferred embodiment, it has been determined that a modified peak detection circuit serves this function very well. An example of this circuit is shown in FIG. 7. It is important to point out that there are many forms of signal processing which can be used to derive this control signal and the FIG. 7 circuit is a simple one which works well for some cases only. A variety of digital signal processing techniques and analog signal processing techniques may be used which include, but are not limited to, phase detection, frequency spectrum analysis, phase vocoding techniques and so forth. Additionally, the signals can be processed to produce control signals which are in some way related to the perceived three-dimensional spatial structure of the original music signal. The signals output from the "n" signal conditioning blocks are fed into the analog signal input ports of microprocessor unit 130X. If "n" is less than or equal to seven, a standard microprocessor card product such as the M68HC11EVBU available from Motorola Corporation can be used. This microprocessor is programmed to successively read each channel and to then output the magnitude of each channel in a serial data stream 131X to a tape IF converter 140X. An example code fragment which outputs a test data block of ASCII characters to tape IF converter 140X is included for reference in Appendix A of this disclosure. The desired analog data should be read with the microcontroller within unit 240 and used in a fashion similar to the ASCII characters in the code fragment. Instructions on how to program this are described in Motorola publications M68HC11EVBU/AD1 and M68FCASS/AD1 and further literature, all provided with the MC68HC11EVBU product by Motorola.

A circuit diagram fragment for tape IF converter 140X is shown in FIG. 8. We contemplate that RS232-to-tape or MIDI-to-tape units could be used as substitutes for the IF converters described herein. This converter type is described in the book *Microcomputer Interfacing* by Harold S. Stone

16

and can be built in a variety of ways. This circuit takes the serial data stream which represents the conditioned levels of the "n" channels of information from the multitrack master tape and converts this serial data to a format 141X that can be recorded on standard audio tape. In this fashion, the control track is recorded side by side with the original two tracks of audio information.

In addition to the information derived from the multitrack master tape, it is desirable for control information to be produced manually by a human operator. This information may take on many forms and can (in many applications) practically be generated only by a human operator. Elements that an operator may wish to control include: display modes that correspond to overall thematic changes in a musical score or special analog controls that relate to quickly paced musical expressions. Elements of these types may be easily input via digital switches 150 or analog controls 160. Likewise, the operator may wish to include information that will later be used by the playback (Acoustic Etch) system. This information could include for example, digital photographs of the musical artists, or textual information that corresponds to the words or themes in the music. This information can also be input via a disk drive 165 or other type of electronic data storage and retrieval mechanism or directly by a computer system. Such information may be created in a multiple of ways including paint programs, 3D modeling programs, digitizing scanners and so on. This information could also consist of system codes and program codes for the VR system 250.

All these alternative controls and information are fed into the microprocessor unit 130Y which contains a program similar to that with which microprocessor unit 130X is programmed. The program for unit 130Y contains additional code that reads the digital I/O ports on the unit in addition to the standard code which reads the analog to digital ports as for microprocessor unit 130X.

The output data (indicative of a control track) is fed to tape IF converter 140Y in a manner similar to that for microprocessor 130X and signal 131X. The converted data stream 141Y output from converter 140Y is then recorded on the remaining track of tape 180T.

FIG. 6 describes the playback phase of the invention. A mass produced copy of the four-track tape 180T, or the actual tape 180T is loaded into a four-track tape playing unit 200. This unit plays the tape and produces 4 audio signals, two of which are standard signals meant to be listened to, while the two others contain control track data that will be processed and sent to VR system 250. The two music audio signals 200R and 200L are fed to a sound processor system which can process the audio signals 200R and 200L in response to control signals 250A from the VR system. The processed audio signals 205R and 205L are fed to an audio amplifier 210 which drives a pair of stereophonic headphones 260 or speakers for the user to listen with.

The other two signals 200X and 200Y are fed to tape IF converters 220Y and 220X which translate the audio signal format control track data into a digital form 221X and 221Y. A circuit diagram fragment for tape IF converter 220Y or 220X is shown in FIG. 9. This converter type is described in the book *Microcomputer Interfacing* by Harold S. Stone.

Microprocessor unit 240 then combines both control signals 221Y and 221X and converts this digital data into a serial data stream suitable for processing by the VR system, for example in the format of an RS232 or MIDI data stream. An example code fragment which accepts a test data block of ASCII characters from tape IF converter 220X or 220Y is

5,513,129

17

included for reference in Appendix A. The desired data should be read with a microcontroller in a suitable format. Instructions on how to program this are described in Motorola publications M68HC113VBU/AD1 and M68FCASS/AD1 and further literature, all provided with the M68HC11EVB product from Motorola.

The music audio signals are also fed to a multichannel audio digitizer 245 with a serial data output that is read by VR system 250. This digitizer converts the music audio signals to digital form for processing by VR system 250, and can also convert other audio sources such as a live microphone 248.

The VR system receives three signals: a signal 261 representing head position and orientation from the VR display 260 or other forms of area of interest tracking information (such as that from an input device of any of the types described above with reference to input device 9 of FIG. 1); a control and data tape signal 241 that is related to the control tracks prerecorded on four-track tape 180T; and digitized audio signals 246 that digitally represent the original audio (which is typically music), and/or any other audio source desired, such as a live microphone 248.

In a preferred embodiment, a VR system 250 comprises a Silicon Graphics Crimson computer outfitted with Reality Engine graphics, a serial port card, and the GL software library and the Fakespace, Inc. VLIB Virtual Reality software package.

In addition to systems administration and miscellaneous programs, the VR system runs the program (comprising steps 400, 410, 420, 430, 440, 450, 460, 470, 480, and 490) which is shown and described in FIG. 16. This program begins by opening the serial port and initializing attached devices (step 400) and then goes on to initializing variables (step 410). The program then creates a table of virtual objects (step 420). Each object comprises an x, y and z location and a geometric description of the object that conforms to GL and VLIB software requirements. A standard set of objects is defined and created and will later be controlled in response to one or both of control signal 241 (representing data in one or more prerecorded control tracks) and audio signal 246.

The system then reads the head position of the tracker 260 (step 430) and then reads the "control track" control signal 241 and audio control signal 246 (steps 440 and 450). In response to this information, any number of programs can be implemented (step 460) to control and create and manipulate the virtual environment in a manner choreographed with the original music signal.

One example of such a virtual reality (VR) program will next be described. This example (which assumes that the VR processor receives both a music signal, and control track information from a prerecorded control track corresponding to the music signal) is provided for illustrative purposes only, and should not be construed to limit the scope of the invention, as broadly defined.

The VR program initially reads the control track information, which may precede the music information on a prerecorded tape (such as tape 180T played by playback device 200 of FIG. 6). The control track information may have been created by an operator during recording of the tape (e.g., using the above-described FIG. 5 apparatus) and can contain descriptions of virtual objects, virtual reality system settings, virtual reality hardware and software settings. The control track information may also contain the body of a software program to be run on the VR processor, in which case the VR program initially residing on the VR

18

processor serves only as a monitor with which to read the program defined by the control track information.

After the control track data is read by the VR program, the VR system reads any digitized music information which corresponds to the control track data, and/or the output of any input devices that are connected to the VR system such as instrument gloves, six-degree-of-freedom trackers, custom human input devices, mice, and the like.

The VR program then creates, destroys, moves or modifies the virtual environment, or virtual objects therein. This can be done using standard VR library software calls, and is preferable based upon all of the forms of data read by the system (including the control track information and corresponding music information) as described above.

Examples of virtual objects that can be created by the VR program will next be described with reference to the display of a virtual environment shown in FIG. 11. Two such virtual objects (310A and 310B) are cylinders of equal diameter and different height. Cylinders 310A and 310B themselves are default objects that are always available in the preferred VR program described herein. The bases of the cylinders are located at the same X and Y and Z location. Preferably, the height of each cylinder is controlled via the control track information and the two heights indirectly represent the first two audio channels 101A and 101B (which are typically music channels) of master tape 100T after being conditioned by the signal conditioners 120A and 120B. If these two audio channels are recordings of, say, a bass drum and a snare drum, then if the user chose to turn and face these objects, the user would see one cylinder (e.g., 310A) which appeared to change height in response to the bass drum, and another (e.g., 310B) which appeared to change height in response to the snare drum. The VR program can be easily written to display other objects in response to the same sounds or to display these or other objects in response to other aspects of the control track.

The data representing the text for objects 320A and 320B (of FIG. 11) is preferably loaded from the control track into the VR program while the tape is playing music and the VR program is running. While running (i.e., reading the control track information from the tape), the VR program loads these objects, along with instructions to display each object at a fixed X and Y (and optional Z) location when the VR program receives a certain signal on the control track. In this manner, lyrics or other song dependent data can be loaded into the VR program using a prerecorded control track, and then displayed based upon the prerecorded control track information. In the preferred VR program embodiment described herein, each of words 320A and 320B is displayed at the same time a singer (represented by a control track corresponding to the music signal) vocalizes the words in the music. In order to achieve this controlled timing, a human operator uses the switches 150 (of FIG. 5) to record the "display" signal as part of the control track, and uses the data in storage device 165 to load the song dependent data.

A model of object 300A (which is shown at later times at positions 300B, 300C, and so on) is loaded into the VR program directly from the control track. After the VR program has loaded the model, the control track instructs the VR program to display the object upon detecting a certain threshold of energy at a specific frequency band of the music information. The VR program performs a spectral analysis of the digitized music information (e.g., digital data 246 in FIG. 6) and tests the specified frequency band for energy level. Upon detecting the threshold level, the VR program creates (displays) the object at a given X, Y, and Z location.

5,513,129

19

Regardless of the status of the spectrum analysis, the VR program automatically changes the Z location (at which the object is to be displayed) by a certain amount once per each increment of elapsed time during running of the program. In this fashion the object 300A can be displayed in a manner so that it appears to recede backwards toward position 300B, and then to position 300C, and so on. A new object would appear on the display at the initial X, Y, and Z location only at instants coinciding with a certain music event, and thus an intermittent stream of objects with a relationship to the frequency content of the source music would appear.

We next discuss several variations on the above-described embodiments of the invention.

The VR processor itself can play digitized music. For example, VR system 250 of FIG. 6 can play digitized music (e.g., generate original music), rather than merely routing digitized music from an external source (e.g., digitizer 245 of FIG. 6).

Sound processing equipment (such as sound processor 205 shown in FIG. 6) can optionally be connected between audio source 200 and amplifier 210. If the sound processing equipment is a convolotron, then the apparent location of the source of the music (when it is output to the user from speakers) can be altered. The sound processing equipment can be controlled to operate in response to the control track information (or in response to the analyzed audio), and the audio (which is typically music) can thus be used to describe as well as control virtual objects, and the control track information (or analyzed audio) can be used to process the audio heard by the user to relocate the apparent source thereof. This technique allows for a much greater realism and correspondence between music and the virtual environment and its objects (assuming that the user wears a head-mounted display, which is preferably a stereoscopic display, along with headphones, so that the user immersively experiences the virtual environment including three-dimensional placement of its virtual objects, using both the senses of sight and hearing).

The audio (e.g., music) can be analyzed (e.g., by analyzer 5 of FIG. 1 or 2) to determine certain aspects of its original three-dimensional nature. One embodiment of this would analyze the delay between right ear and left ear correlated sounds. This delay can then be mapped roughly to an angle relative to the user's head orientation.

The foregoing describes two basic methods to enable the user to experience sounds with a controlled apparent source location: one is to convolve the sound and place it in space; the other is to analyze the sound and determine where the user will think it is placed in space.

20

Many conventional recording studios process music to achieve a three dimensional effect. Such processing information could be stored in the control track of the invention, for later use by a VR system to help place virtual objects and to set system parameters in instruments (such as a convolotron) that may be used as part of the VR system. This would be especially useful if the music recording is made using binaural heads and other such spatial recording equipment and techniques.

The recording medium for the inventive prerecorded control tracks does not need to be a four-track audio tape. In fact, the compact disk (CD) and Digital Audio Tape (DAT) formats already offer control track capabilities. In addition to these capabilities, these and other formats can be modified to contain more control track information. For example, the prerecorded control track(s) need not be recorded as a separate track. In order to retrofit to existing consumer audio equipment, the control track information could be stored in a subsonic or supersonic fashion on the existing audio information. Provision of such subsonic modulations would decrease the data rate, and thus the signal conditioning blocks would need to have their values adjusted. Provision of such supersonic modulations would likely introduce difficulties when using audio tape systems to implement the invention.

The original multitrack and two-track tape machines employed in the systems of FIGS. 5 and 6 can be replaced by any form of an audio source. In the near future, it is expected that audio recording and playback devices suitable for use in embodiments of the invention, will be inexpensively implementable as completely digital machines.

FIGS. 5 and 6 describe a principally analog device, which can easily be implemented digitally, in alternative embodiments of the invention.

When prerecording the control track(s), the recording does not need to be performed in a continuous real-time fashion. It can be edited over time much as master audio tapes are created, using many passes to get it right, building up or deleting control track information in multiple passes.

It should be understood that components can be exchanged between the various embodiments described herein.

Various other modifications and alterations in the method and apparatus of the invention will be apparent to those skilled in the art without departing from the scope and spirit of this invention. Although the invention has been described in connection with specific preferred embodiments, it should be understood that the invention as claimed should not be unduly limited to such specific embodiments.

APPENDIX A

```

0001
0002
0003
0004
0005
0006
0007
0008
0009
0010 1000
0011 1003
0012 1004
0013 102b
0014 102c
0015 102d
0016 102e
0017 102f
0018
0019 100e
0020 1018
0021 1020
0022 1023
0023 1022
0024
0025 1010
0026 1021
0027
0028
0029
0030 00eb
0031
0032 00e8 7e 01 87
0033
0034 0100
0035
0036
0037 0100 84 30
0038 0102 b7 10 21
0039 0105 86 04
0040 0107 b7 10 23
0041
0042 010e 7f 01 83
0043
0044 010d fc 10 0e
0045 0110 fd 01 81
0046
0047 0113 c6 00
0048 0115 f7 10 04
0049
0050 0118 7c 01 85
0051
0052 011b 0e
0053
0054
0055 011c 18 c4 00 00
0056 0120 8d 32
0057 0122 18 09
0058 0124 16 26
0059 0126 b6 01 86
0060 0129 81 80
0061 012b 27 04
0062 012d 8d 42
0063 012f 20 eb
0064
0065 0131 8d 21
0066 0133 b6 01 86
0067 0136 81 80
0068 0138 27 f7
0069
0070 013e 8d 18
0071
0072 013c c6 ff
0073 013e f7 10 04
0074 0141 7f 10 04
0075
0076
0077
0078
0079
0080
0081
0082
0083
0084
0085 0144 b6 01 86
0086 0147 81 41
0087 0149 2d 61
0088 014b 81 7a
0089 014d 2e cd
0090 014f bd ff b8
0091
0092 0152 20 e6
0093
0094
0095
0096
0097 0154 30
0098 0155 08 00 08
0099 0158 7f 01 86
0100
0101 015b 8d 14
0102 0164 2e 09
0103
0104 015f 8d 10
0105 0161 2e 05
0106
0107 0163 18 00
0108 0165 08
*****
***** Type II Software for 68HC11 *****
***** Copyright Faka Space Labs *****
***** 1990 - By I.E.M and K.T.B *****
*****

* Buffer definitions

REGS EQU $1000
PORTC EQU $1003 * Port C is input (Data from HP2020)
PORTB EQU $1004 * 0:5 - /OE for HP2020s 6: HI/Lo byte 7: /Reset
RAB EQU $102B
SCCR1 EQU $102C
SCCR2 EQU $102D
SCSR EQU $102E
SCDAT EQU $102F

TCNT EQU $100E * Timer 16 bit
TOC2 EQU $1018 * Timer out comp 2
TCTL1 EQU $1020 * Timer control
TFLG1 EQU $1023
TMSK1 EQU $1022

TIC1 EQU $1010 * TIMER INPUT CAPTURE 1
TCTL2 EQU $1021 * Timer input capt ctrl reg

* Pseud vact for TIC1
ORG $00E8
JMP TICLINT
ORG $0100 * RAM 0100-01FF

START
LDA #50
STAA TCTL2 * Set TIC1 to capture on either edge
LDA #804
STAA TMSK1 * Enable interrupts

CLR DELTA
LDB TCNT * read timer
STD PEDGE * current time stored in PEDGE

LDAB #50
STAB PORTB

INC VALID
CLI

LOOP
HEADER LDY #0
BSR GETBYTE
BNE *
LDA DATA * Must be only 1 bit set
CMA #50
BEQ SYNCD
BSR MID
BRA HEADER
SYNCD
BSR GETBYTE
LDA DATA
CMA #50
BEQ SYNCD

INSMC BSR GETBYTE

LEAD #FF
STAB PORTB
CLR PORTB

* LDA DATA
* JSR $FFB2
* LDA DATA
* JSR $FFD6
* LDA #
* JSR $FFB8
* LDA #
* JSR $FFB8

LDA DATA
CMA #A
BIT HEADER
CMA #2
BGT HEADER
JSR $FFB8

BRA INSYN

* *****
GETBYTE
PSHX * sets DATA to read value
LDX #8 * and Y to number of 1 bits
CLR DATA

BYTEL BSR MID
BGT ITIB0

BSR MID
BGT ITIB0

TISI INY
SEC
    
```

APPENDIX A

0109 0166 20 01	BRA	GOTBIT	
0110			
0111 0168 0c	ITISO	CLC	
0112			
0113 0169 79 01 86	GOTBIT	ROL	DATA
0114			
0115 016c 09	DEX		
0116 016d 26 0c	BNE	BYTEL	
0117			
0118			
0119 016f 38	PULX		
0120 0170 39	RTS		
0121			
0122	*		
0123			
0124			
0125 0171 7d 01 85	MID	TST	VALID
0126 0174 26 fb	BNE	MID	
0127 0176 7c 01 85	INC	VALID	
0128			
0129 0179 fc 01 83	LDD	DELTA	
0130 017c 1a 83 D2 58	CPD	#600	
0131 0180 39	RTS		
0132			
0133	* *****		
0134			
0135 0181	PEDGE	RMB	2
0136 0183	DELTA	RMB	2
0137 0185	VALID	RMB	1
0138 0186	DATA	RMB	1
0139			
0140	* *****		
0141			
0142 0187 fc 10 10	TICLINT	LDD	TIC1
0143 018a b3 01 81	SUND	PEDGE	* D - PEDGE - This edge
0144 018d fd 01 83	STD	DELTA	* store in DELTA
0145 0190 fc 10 10	LDD	TIC1	
0146 0193 fd 01 81	STD	PEDGE	
0147 0196 86 04	LDAA	#904	
0148 0198 b7 10 23	STAA	TFLGL	* Clear the interrupt
0149 019b 7f 01 85	CLR	VALID	
0150 019e 3b	RTI		
0151			
0152			

5,513,129

25

26

APPENDIX A

```

0001
0002
0003
0004
0005
0006
0007
0008
0009
0010 0033
0011
0012 0033
0013 0047
0014
0015 1000
0016 1003
0017 1004
0018 102b
0019 102c
0020 102d
0021 102e
0022 102f
0023
0024 100e
0025 1011
0026 1020
0027 1023
0028 1022
0029
0030
0031
0032
0033 00dc
0034
0035 00dc 7e b6 90
0036
0037
0038
0039 0100
0040
0041 0100
0042 0102
0043
0044
0045
0046 b600
0047
0048
0049 b600 8e 00 47
0050
0051 b603 86 7a
0052 b605 97 dc
0053 b607 c9 b6 90
0054 b60a d1 dd
0055
0056
0057
0058
0059 b60c 86 40
0060 b60e b7 10 20
0061 b611 b7 10 22
0062
0063 b614 7f d1 02
0064
0065 b617 c9 m0 00
0066 b61a fd d1 00
0067
0068 b61d fc 10 1a
0069 b620 f3 d1 00
0070 b623 fd 10 18
0071
0072 b626 86 ff
0073 b628 c6 00
0074 b62a f7 10 04
0075
0076 b62d 0e
0077
0078
0079
0080 b62e 86 80
0081 b630 8d 21
0082 b632 86 80
0083 b634 8d 24
0084 b636 86 80
0085 b638 8d 20
0086 b63a 86 80
0087 b63c 8d 1c
0088 b63e 86 80
0089 b640 8d 18
0090 b642 86 80
0091 b644 8d 14
0092 b646 86 80
0093 b648 8d 10
0094 b64a 86 80
0095 b64c 8d 0c
0096
0097 b64e c6 1e
0098 b650 86 41
0099 b652 1b
0100 b653 8d 05
0101 b655 5a
0102 b656 16 f8
0103
0104 b658 20 04
0105
0106
0107
0108 b65a 18 ce 00 08

```

```

*****
***** Tape II Software for 68HC11 *****
***** Copyright Fair Space Labs *****
***** 1990 - By I.E.M and N.T.B *****
*****
* Buffalo definitions
CRG $33
RMB      2D
USTACK   JMB      JO
REG25    EQU      $1000
PORTC    EQU      $1007 * Port C is input (Data from HP2020)
PORTD    EQU      $1004 * 015 - /OE for HP2020 6: HI/L0 byte 7: /Reset
RAID     EQU      $1029
SCCR1    EQU      $102c
SCCR2    EQU      $102d
SCSR     EQU      $102E
HCDAT    EQU      $102F
TCNT     EQU      $100E * Timer 16 bits
TOC2     EQU      $1018 * Timer out comp 2
TCCTL    EQU      $1020 * Timer control
TFLG1    EQU      $1023
TMSK1    EQU      $1022
* Pseud vect for TOC2
CRG $00DC
PSVCTL1  JMP      TOC2INT
* Res vars
CRG $0100
FWIDTH   RMB      2
DCNT     RMB      1
* Main program
CRG $B600
START
LDS      #USTACK
LDAA    #57E * JUMP OPCODE
STAA    PSVCTL1
LDX     #TOC2INT
STX     PSVCTL1+1
INITDCW
LDAA    #540
STAA    TCCTL
STAA    TMSK1 * Set TOC2 to toggle mode
           * enables interrupts
CLR     DCNT
LDD     #62000
STD     FWIDTH
SZA
LDD     TCNT * read timer
ADD    FWIDTH
STD     TOC2 * store in TOC2
LDAA    #5FF
LDAB    #50B
STAB    PORCB
CLI
LOOP
LDAA    #580
BSR     SENDA
LDAA    #590
BSR     SENDA
LDAA    #5A0
BSR     SENDA
LDAA    #5B0
BSR     SENDA
LDAA    #5C0
BSR     SENDA
LDAA    #5D0
BSR     SENDA
LDAA    #5E0
BSR     SENDA
LDAA    #5F0
BSR     SENDA
LDAB    #50B
BSR     SENDA
LDAA    #580
BSR     SENDA
LDAA    #590
BSR     SENDA
LDAA    #5A0
BSR     SENDA
LDAA    #5B0
BSR     SENDA
LDAA    #5C0
BSR     SENDA
LDAA    #5D0
BSR     SENDA
LDAA    #5E0
BSR     SENDA
LDAA    #5F0
BSR     SENDA
ALPHA   #26
ALPHA   #1A
BSR     SENDA
DECB   SENDA
BNZ     ALPHA
BRA     LOOP
*****
SEMDA   LDY     #6

```

APPENDIX A

0109 b65e 37	PSHB		
0110 b65f c6 00	LDAB	#900	
0111 b661 f7 10 04	STAB	PORTB	
0112 b664 c6 ff	LDAB	#9FF	
0113 b666 f7 10 04	STAB	PORTB	
0114 b669 33	PULB		
0115			
0116 b66a 48	BITLOOP	LSLA	
0117 b66b 24 04	BCC	BITO	
0118			
0119 b66d 8d 0e	BIT1	BSR	SEND1
0120 b66f 20 02	BRA	DONEBIT	
0121			
0122 b671 8d 05	BITO	BSR	SEND0
0123			
0124 b673 18 09	DONEBIT	DEV	
0125 b675 26 f3	BNE	BITLOOP	
0126 b677 39	RTS		
0127			
0128	*		
0129			
0130			
0131 b678 ca 03 20	SEND0	LDX	#800
0132 b67b 20 07	BRA	PULSE	
0133			
0134 b67d ca 01 90	SEND1	LDX	#400
0135 b680 8d 02	BSR	PULSE	
0136 b682 20 00	BRA	PULSE	
0137			
0138 b684 ff 01 00	PULSE	STX	PWIDTH
0139 b687 7c 01 02	INC	DONE	
0140 b68a 7d 01 02	WAIT4IT	TST	DONE
0141 b68d 26 fb	BNE	WAIT4IT	
0142 b68f 39	RTS		
0143			
0144			
0145	*		
0146			
0147			
0148 b690 fc 01 00	TOC2INT	LDX	PWIDTH
0149 b693 f3 10 18	ADD	TOC2	* Add pulse width
0150 b696 fd 10 18	STD	TOC2	* and store in TOC2
0151 b699 86 40	LDAA	#940	
0152 b69b b7 10 23	STAA	TFLG1	* Clear the interrupt
0153 b69e 7f 01 02	CLR	DONE	
0154 b6a1 3b	RTI		
0155			
0156			

5,513,129

29

What is claimed is:

1. A method for controlling production of a virtual environment by a virtual reality computer system, including the steps of:
 - (a) processing music signals to generate control signals having music and/or control information; and
 - (b) operating the virtual reality computer system in response to the control signals to generate said virtual environment.
2. The method of claim 1, wherein step (b) includes the step of:
 - producing a graphic display of the virtual environment on a display device of a type coupled to a head of a human user which provides an immersive visual experience of said virtual environment to the user.
3. The method of claim 2, wherein the graphic display is populated with at least one animated virtual object, where at least one characteristic of the virtual object changes in response to at least one of the music signals.
4. The method of claim 2, wherein the graphic display is a stereoscopic representation of a three-dimensional virtual environment.
5. A method for controlling production of a virtual environment by a virtual reality computer system, including the steps of:
 - (a) prerecording a control track having audio and/or control information corresponding to an audio signal; and
 - (b) operating the virtual reality computer system in response to said prerecorded control track to generate said virtual environment.
6. The method of claim 5, wherein step (b) includes the step of producing a graphic display of the virtual environment on a display device, and also including the steps of:
 - (c) supplying the audio signal to the virtual reality computer system; and
 - (d) operating the virtual reality computer system in response to both said audio signal and said prerecorded control track to generate said virtual environment.
7. The method of claim 6, wherein step (c) includes the step of supplying the audio signal to the virtual reality computer system with a first delay relative to the prerecorded control track, wherein the first delay is selected to enable generation of sounds in response to the audio signal in a manner so that the sounds have a desired time relationship to the graphic display.
8. The method of claim 5, wherein step (a) includes the step of automatically generating the control track by processing the audio signal.
9. The method of claim 5, wherein step (a) includes the step of manually operating an input device to generate the control track.
10. A method for controlling a computer system, including the steps of:
 - (a) prerecording a control track having audio and/or control information corresponding to an audio signal; and
 - (b) operating the computer system in response to said prerecorded control track.
11. The method of claim 10, also including the steps of:
 - (c) supplying the audio signal to the computer system; and
 - (d) operating the computer system in response to both the audio signal and the prerecorded control track.
12. A virtual reality computer system, including:
 - means for supplying a first signal selected from a group consisting of a control signal having music and/or

30

- control information generated in response to a music signal, a prerecorded control track having music and/or control information corresponding to the music signal, and a control signal having music and/or control information generated in response to the prerecorded control track; and
- means for receiving the first signal and influencing action within a virtual environment in response to said first signal.
13. The apparatus of claim 12, wherein the means for supplying the first signal includes an analysis apparatus having means for receiving said music signal in digital or analog form, and processing said music signal to produce control information for modification of objects in the virtual environment.
14. The apparatus of claim 12, wherein said music signal is delayed in time to compensate for delays in other parts of the virtual reality computer system.
15. The apparatus of claim 12, wherein the means for supplying the first signal includes a music playing means for supplying said music signal.
16. A virtual reality computer system for producing a virtual environment, including:
 - means for prerecording a control track having music and/or control information corresponding to a music signal; and
 - means for producing the virtual environment in response to said prerecorded control track.
17. The system of claim 16, wherein the means for producing the virtual environment includes:
 - a display device; and
 - a means for producing a graphic display of the virtual environment on the display device.
18. The system of claim 16, also including:
 - means for supplying the music signal to the means for producing the virtual environment, and wherein the means for producing the virtual environment includes means for producing said virtual environment in response to both said music signal and said prerecorded control track.
19. Apparatus as in claim 16, wherein said control track contains additional information to that which can be extracted from the music signal.
20. The system of claim 16, wherein said control track is time shifted relative to the music signal to compensate for delays in said virtual reality computer system.
21. A virtual reality computer system, including:
 - a source of a music signal; and
 - an apparatus for extracting information from the music signal for modification of objects in a virtual environment.
22. A computer system, including:
 - means for prerecording a control track having audio and/or control information corresponding to an audio signal; and
 - a processor which receives the control track and which is programmed with software for operating the computer system in response to said control track.
23. The system of claim 22, also including:
 - means for supplying the audio signal to the processor, and wherein the processor is programmed with software for operating the computer system in response to both the audio signal and the control track.

* * * * *

J. Donald McCarthy (SBN 69)
DUANE MORRIS LLP
865 S. Figueroa Street, Suite 3100
Los Angeles, CA 90017-5450
Telephone: (213) 689-7400
Facsimile: (213) 689-7401
E-mail: jdmccarthy@duanemorris.com
Attorneys for Plaintiff PRINCETON DIGITAL
IMAGE CORPORATION

**UNITED STATES DISTRICT COURT
CENTRAL DISTRICT OF CALIFORNIA**

PRINCETON DIGITAL IMAGE CORPORATION,

PLAINTIFF(S)

v.

ACTIVISION PUBLISHING, INC.

DEFENDANT(S).

CASE NUMBER

CV12-01134 VBK

SUMMONS

TO: DEFENDANT(S): ACTIVISION PUBLISHING, INC.

A lawsuit has been filed against you.

Within 21 days after service of this summons on you (not counting the day you received it), you must serve on the plaintiff an answer to the attached complaint amended complaint counterclaim cross-claim or a motion under Rule 12 of the Federal Rules of Civil Procedure. The answer or motion must be served on the plaintiff's attorney, J. Donald McCarthy, whose address is 865 S. Figueroa Street, Suite 3100, Los Angeles, CA 90017-5450. If you fail to do so, judgment by default will be entered against you for the relief demanded in the complaint. You also must file your answer or motion with the court.

FEB - 9 2012

Dated: _____

Clerk, U.S. District Court

By: _____

Deputy Clerk

(Seal of the Court)

[Use 60 days if the defendant is the United States or a United States agency, or is an officer or employee of the United States. Allowed 60 days by Rule 12(a)(3)].

UNITED STATES DISTRICT COURT, CENTRAL DISTRICT OF CALIFORNIA
CIVIL COVER SHEET

I (a) PLAINTIFFS (Check box if you are representing yourself <input type="checkbox"/>) PRINCETON DIGITAL IMAGE CORPORATION	DEFENDANTS ACTIVISION PUBLISHING, INC.
(b) Attorneys (Firm Name, Address and Telephone Number. If you are representing yourself, provide same.) J. Donald McCarthy (SBN 69864) DUANE MORRIS LLP 865 S. Figueroa Street, Suite 3100 Los Angeles, CA 90017-5450 Telephone: 213-689-7400 / Telephone: 213-689-7401	Attorneys (If Known)

II. BASIS OF JURISDICTION (Place an X in one box only.) <input type="checkbox"/> 1 U.S. Government Plaintiff <input checked="" type="checkbox"/> 3 Federal Question (U.S. Government Not a Party) <input type="checkbox"/> 2 U.S. Government Defendant <input type="checkbox"/> 4 Diversity (Indicate Citizenship of Parties in Item III)	III. CITIZENSHIP OF PRINCIPAL PARTIES - For Diversity Cases Only (Place an X in one box for plaintiff and one for defendant.) <table style="width:100%; border-collapse: collapse;"> <tr> <td style="width:30%;"></td> <td style="width:10%; text-align: center;">PTF</td> <td style="width:10%; text-align: center;">DEF</td> <td style="width:40%;"></td> <td style="width:10%; text-align: center;">PTF</td> <td style="width:10%; text-align: center;">DEF</td> </tr> <tr> <td>Citizen of This State</td> <td style="text-align: center;"><input type="checkbox"/> 1</td> <td style="text-align: center;"><input type="checkbox"/> 1</td> <td>Incorporated or Principal Place of Business in this State</td> <td style="text-align: center;"><input type="checkbox"/> 4</td> <td style="text-align: center;"><input type="checkbox"/> 4</td> </tr> <tr> <td>Citizen of Another State</td> <td style="text-align: center;"><input type="checkbox"/> 2</td> <td style="text-align: center;"><input type="checkbox"/> 2</td> <td>Incorporated and Principal Place of Business in Another State</td> <td style="text-align: center;"><input type="checkbox"/> 5</td> <td style="text-align: center;"><input type="checkbox"/> 5</td> </tr> <tr> <td>Citizen or Subject of a Foreign Country</td> <td style="text-align: center;"><input type="checkbox"/> 3</td> <td style="text-align: center;"><input type="checkbox"/> 3</td> <td>Foreign Nation</td> <td style="text-align: center;"><input type="checkbox"/> 6</td> <td style="text-align: center;"><input type="checkbox"/> 6</td> </tr> </table>		PTF	DEF		PTF	DEF	Citizen of This State	<input type="checkbox"/> 1	<input type="checkbox"/> 1	Incorporated or Principal Place of Business in this State	<input type="checkbox"/> 4	<input type="checkbox"/> 4	Citizen of Another State	<input type="checkbox"/> 2	<input type="checkbox"/> 2	Incorporated and Principal Place of Business in Another State	<input type="checkbox"/> 5	<input type="checkbox"/> 5	Citizen or Subject of a Foreign Country	<input type="checkbox"/> 3	<input type="checkbox"/> 3	Foreign Nation	<input type="checkbox"/> 6	<input type="checkbox"/> 6
	PTF	DEF		PTF	DEF																				
Citizen of This State	<input type="checkbox"/> 1	<input type="checkbox"/> 1	Incorporated or Principal Place of Business in this State	<input type="checkbox"/> 4	<input type="checkbox"/> 4																				
Citizen of Another State	<input type="checkbox"/> 2	<input type="checkbox"/> 2	Incorporated and Principal Place of Business in Another State	<input type="checkbox"/> 5	<input type="checkbox"/> 5																				
Citizen or Subject of a Foreign Country	<input type="checkbox"/> 3	<input type="checkbox"/> 3	Foreign Nation	<input type="checkbox"/> 6	<input type="checkbox"/> 6																				
IV. ORIGIN (Place an X in one box only.) <input checked="" type="checkbox"/> 1 Original Proceeding <input type="checkbox"/> 2 Removed from State Court <input type="checkbox"/> 3 Remanded from Appellate Court <input type="checkbox"/> 4 Reinstated or Reopened <input type="checkbox"/> 5 Transferred from another district (specify): <input type="checkbox"/> 6 Multi-District Litigation <input type="checkbox"/> 7 Appeal to District Judge from Magistrate Judge																									

V. REQUESTED IN COMPLAINT: JURY DEMAND: Yes No (Check 'Yes' only if demanded in complaint.)
CLASS ACTION under F.R.C.P. 23: Yes No **MONEY DEMANDED IN COMPLAINT: \$** _____

VI. CAUSE OF ACTION (Cite the U. S. Civil Statute under which you are filing and write a brief statement of cause. Do not cite jurisdictional statutes unless diversity.)
 Patent infringement under 35 U.S.C. § 271

VII. NATURE OF SUIT (Place an X in one box only.)

OTHER STATUTES <input type="checkbox"/> 400 State Reapportionment <input type="checkbox"/> 410 Antitrust <input type="checkbox"/> 430 Banks and Banking <input type="checkbox"/> 450 Commerce/ICC Rates/etc. <input type="checkbox"/> 460 Deportation <input type="checkbox"/> 470 Racketeer Influenced and Corrupt Organizations <input type="checkbox"/> 480 Consumer Credit <input type="checkbox"/> 490 Cable/Sat TV <input type="checkbox"/> 810 Selective Service <input type="checkbox"/> 850 Securities/Commodities/Exchange <input type="checkbox"/> 875 Customer Challenge 12 USC 3410 <input type="checkbox"/> 890 Other Statutory Actions <input type="checkbox"/> 891 Agricultural Act <input type="checkbox"/> 892 Economic Stabilization Act <input type="checkbox"/> 893 Environmental Matters <input type="checkbox"/> 894 Energy Allocation Act <input type="checkbox"/> 895 Freedom of Info. Act <input type="checkbox"/> 900 Appeal of Fee Determination Under Equal Access to Justice <input type="checkbox"/> 950 Constitutionality of State Statutes	CONTRACT <input type="checkbox"/> 110 Insurance <input type="checkbox"/> 120 Marine <input type="checkbox"/> 130 Miller Act <input type="checkbox"/> 140 Negotiable Instrument <input type="checkbox"/> 150 Recovery of Overpayment & Enforcement of Judgment <input type="checkbox"/> 151 Medicare Act <input type="checkbox"/> 152 Recovery of Defaulted Student Loan (Excl. Veterans) <input type="checkbox"/> 153 Recovery of Overpayment of Veteran's Benefits <input type="checkbox"/> 160 Stockholders' Suits <input type="checkbox"/> 190 Other Contract <input type="checkbox"/> 195 Contract Product Liability <input type="checkbox"/> 196 Franchise REAL PROPERTY <input type="checkbox"/> 210 Land Condemnation <input type="checkbox"/> 220 Foreclosure <input type="checkbox"/> 230 Rent Lease & Ejectment <input type="checkbox"/> 240 Torts to Land <input type="checkbox"/> 245 Tort Product Liability <input type="checkbox"/> 290 All Other Real Property	TORTS PERSONAL INJURY <input type="checkbox"/> 310 Airplane <input type="checkbox"/> 315 Airplane Product Liability <input type="checkbox"/> 320 Assault, Libel & Slander <input type="checkbox"/> 330 Fed. Employers' Liability <input type="checkbox"/> 340 Marine <input type="checkbox"/> 345 Marine Product Liability <input type="checkbox"/> 350 Motor Vehicle <input type="checkbox"/> 355 Motor Vehicle Product Liability <input type="checkbox"/> 360 Other Personal Injury <input type="checkbox"/> 362 Personal Injury-Med Malpractice <input type="checkbox"/> 365 Personal Injury-Product Liability <input type="checkbox"/> 368 Asbestos Personal Injury Product Liability IMMIGRATION <input type="checkbox"/> 462 Naturalization Application <input type="checkbox"/> 463 Habeas Corpus-Alien Detainee <input type="checkbox"/> 465 Other Immigration Actions	TORTS PERSONAL PROPERTY <input type="checkbox"/> 370 Other Fraud <input type="checkbox"/> 371 Truth in Lending <input type="checkbox"/> 380 Other Personal Property Damage <input type="checkbox"/> 385 Property Damage Product Liability BANKRUPTCY <input type="checkbox"/> 22 Appeal 28 USC 158 <input type="checkbox"/> 423 Withdrawal 28 USC 157 CIVIL RIGHTS <input type="checkbox"/> 441 Voting <input type="checkbox"/> 442 Employment <input type="checkbox"/> 443 Housing/Accommodations <input type="checkbox"/> 444 Welfare <input type="checkbox"/> 445 American with Disabilities - Employment <input type="checkbox"/> 446 American with Disabilities - Other <input type="checkbox"/> 440 Other Civil Rights	PRISONER PETITIONS <input type="checkbox"/> 510 Motions to Vacate Sentence Habeas Corpus <input type="checkbox"/> 530 General <input type="checkbox"/> 535 Death Penalty <input type="checkbox"/> 540 Mandamus/Other <input type="checkbox"/> 550 Civil Rights <input type="checkbox"/> 555 Prison Condition FORFEITURE/PENALTY <input type="checkbox"/> 610 Agriculture <input type="checkbox"/> 620 Other Food & Drug <input type="checkbox"/> 625 Drug Related Seizure of Property 21 USC 881 <input type="checkbox"/> 630 Liquor Laws <input type="checkbox"/> 640 R.R. & Truck <input type="checkbox"/> 650 Airline Regs <input type="checkbox"/> 660 Occupational Safety/Health <input type="checkbox"/> 690 Other	LABOR <input type="checkbox"/> 710 Fair Labor Standards Act <input type="checkbox"/> 720 Labor/Mgmt. Relations <input type="checkbox"/> 730 Labor/Mgmt. Reporting & Disclosure Act <input type="checkbox"/> 740 Railway Labor Act <input type="checkbox"/> 790 Other Labor Litigation <input type="checkbox"/> 791 Empl. Ret. Inc. Security Act PROPERTY RIGHTS <input type="checkbox"/> 820 Copyrights <input checked="" type="checkbox"/> 830 Patent <input type="checkbox"/> 840 Trademark SOCIAL SECURITY <input type="checkbox"/> 61 HIA(1395ff) <input type="checkbox"/> 862 Black Lung (923) <input type="checkbox"/> 863 DIWC/DIWW 405(g) <input type="checkbox"/> 864 SSID Title XVI <input type="checkbox"/> 865 RSI (405(g)) FEDERAL TAX SUITS <input type="checkbox"/> 870 Taxes (U.S. Plaintiff or Defendant) <input type="checkbox"/> 871 IRS-Third Party 26 USC 7609
---	--	--	--	---	--

FOR OFFICE USE ONLY: Case Number: _____
AFTER COMPLETING THE FRONT SIDE OF FORM CV-71, COMPLETE THE INFORMATION REQUESTED BELOW.

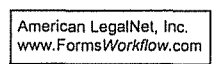

UNITED STATES DISTRICT COURT, CENTRAL DISTRICT OF CALIFORNIA
CIVIL COVER SHEET

VIII(a). IDENTICAL CASES: Has this action been previously filed in this court and dismissed, remanded or closed? No Yes

If yes, list case number(s): _____

VIII(b). RELATED CASES: Have any cases been previously filed in this court that are related to the present case? No Yes

If yes, list case number(s): _____

Civil cases are deemed related if a previously filed case and the present case:

(Check all boxes that apply)

- A. Arise from the same or closely related transactions, happenings, or events; or
- B. Call for determination of the same or substantially related or similar questions of law and fact; or
- C. For other reasons would entail substantial duplication of labor if heard by different judges; or
- D. Involve the same patent, trademark or copyright, and one of the factors identified above in a, b or c also is present.

IX. VENUE: (When completing the following information, use an additional sheet if necessary.)

(a) List the County in this District; California County outside of this District; State if other than California; or Foreign Country, in which EACH named plaintiff resides.
 Check here if the government, its agencies or employees is a named plaintiff. If this box is checked, go to item (b).

County in this District:*	California County outside of this District; State, if other than California; or Foreign Country
	Texas

(b) List the County in this District; California County outside of this District; State if other than California; or Foreign Country, in which EACH named defendant resides.
 Check here if the government, its agencies or employees is a named defendant. If this box is checked, go to item (c).

County in this District:*	California County outside of this District; State, if other than California; or Foreign Country
Los Angeles	

(c) List the County in this District; California County outside of this District; State if other than California; or Foreign Country, in which EACH claim arose.
Note: In land condemnation cases, use the location of the tract of land involved.

County in this District:*	California County outside of this District; State, if other than California; or Foreign Country
Los Angeles	

* Los Angeles, Orange, San Bernardino, Riverside, Ventura, Santa Barbara, or San Luis Obispo Counties

Note: In land condemnation cases, use the location of the tract of land involved

X. SIGNATURE OF ATTORNEY (OR PRO PER):

J. Donald McCutley

Date February 9, 2012

Notice to Counsel/Parties: The CV-71 (JS-44) Civil Cover Sheet and the information contained herein neither replace nor supplement the filing and service of pleadings or other papers as required by law. This form, approved by the Judicial Conference of the United States in September 1974, is required pursuant to Local Rule 3 -1 is not filed but is used by the Clerk of the Court for the purpose of statistics, venue and initiating the civil docket sheet. (For more detailed instructions, see separate instructions sheet.)

Key to Statistical codes relating to Social Security Cases:

Nature of Suit Code	Abbreviation	Substantive Statement of Cause of Action
861	HIA	All claims for health insurance benefits (Medicare) under Title 18, Part A, of the Social Security Act, as amended. Also, include claims by hospitals, skilled nursing facilities, etc., for certification as providers of services under the program. (42 U.S.C. 1935FF(b))
862	BL	All claims for "Black Lung" benefits under Title 4, Part B, of the Federal Coal Mine Health and Safety Act of 1969. (30 U.S.C. 923)
863	DIWC	All claims filed by insured workers for disability insurance benefits under Title 2 of the Social Security Act, as amended; plus all claims filed for child's insurance benefits based on disability. (42 U.S.C. 405(g))
863	DIWW	All claims filed for widows or widowers insurance benefits based on disability under Title 2 of the Social Security Act, as amended. (42 U.S.C. 405(g))
864	SSID	All claims for supplemental security income payments based upon disability filed under Title 16 of the Social Security Act, as amended.
865	RSI	All claims for retirement (old age) and survivors benefits under Title 2 of the Social Security Act, as amended. (42 U.S.C. (g))