

COPY

1 RUSS, AUGUST & KABAT
2 Marc A. Fenster, State Bar No. 181067
3 Email: mfenster@raklaw.com
4 Alexander C.D. Giza, State Bar No. 212327
5 Email: agiza@raklaw.com
6 Fredricka Ung, State Bar No. 253794
7 Email: fung@raklaw.com
8 12424 Wilshire Boulevard, 12th Floor
9 Los Angeles, California 90025
10 Telephone: (310) 826-7474
11 Facsimile:(310) 826-6991

12 Attorneys for Plaintiff
13 AIM IP, LLC

14 UNITED STATES DISTRICT COURT
15 CENTRAL DISTRICT OF CALIFORNIA
16 SOUTHERN DIVISION

FILED
2012 JUN -7 PM 3:13
CLERK U.S. DISTRICT COURT
CENTRAL DIST. OF CALIF.
SANTA ANA

17 Case No. SACV 12 - 00904 CJC (RNBx)

18 AIM IP, LLC, a California
19 limited liability company,

20 Plaintiff,

21 vs.

22 AIM IP, LLC'S COMPLAINT FOR
23 PATENT INFRINGEMENT

24 DIALOGIC INC., a California
25 corporation,

26 Defendant.

27 JURY TRIAL DEMANDED

RUSS, AUGUST & KABAT

RUSS, AUGUST & KABAT

1
2
3
4
5
6
7
8
9
10
11
12
13
14
15
16
17
18
19
20
21
22
23
24
25
26
27
28

Plaintiff AIM IP, LLC (“AIM IP”) alleges as follows:

1. This case is an action for patent infringement under the Patent Laws of the United States, as set forth in 35 U.S.C. §§ 271 and 280 through 285.

PARTIES

2. AIM IP is a limited liability company organized under the laws of the State of California, with its principal place of business located at 26522 La Alameda Avenue, Suite 360, Mission Viejo, California 92691.

3. On information and belief, Defendant Dialogic Inc. (“Dialogic”) is a corporation organized under the laws of the State of California, with its principal place of business located at 926 Rock Avenue, San Jose, California 95131, and is doing business in this Judicial District and elsewhere.

JURISDICTION AND VENUE

4. This Court has federal subject matter jurisdiction over this action under 28 U.S.C. §§1331, 1332(a)(1), 1332(c)(1) and 1338(a).

5. Venue is proper in this Court pursuant to 28 U.S.C. §§1391(a), 1391(c), and 1400(b), including without limitation because Dialogic is advertising, marketing, using, selling, and/or offering to sell products in this Judicial District.

FIRST CAUSE OF ACTION FOR PATENT INFRINGEMENT

6. AIM IP repeats and realleges the allegations contained in paragraphs 1 through 5 above, inclusive, as if fully repeated and restated herein.

7. AIM IP is the owner by assignment of United States Patent No. 5,920,853 (“the ’853 Patent”) entitled “Signal Compression Using Index Mapping Technique For The Sharing Of Quantization Tables.” The ’853 Patent issued on July 6, 1999. A true and correct copy of the ’853 Patent is attached as Exhibit A.

8. Adil Benyassine, Huan-Yu Su, and Eyal Shlomot are listed as the inventors of the ’853 Patent. The three inventors were employees of Rockwell International Corporation, the initial assignee of the patent. Rockwell developed the technology of the ’853 Patent and contributed to the promulgation of the

RUSS, AUGUST & KABAT

1 International Telecommunications Union, Telecommunications Standardization
2 Sector of ITU ("ITU-T"), Series G: Transmission Systems and Media, Annex B: A
3 silence compression scheme for G.729 optimized for terminals conforming to
4 Recommendation V.70 ("G.729B") standard. The '853 Patent was appropriately
5 disclosed as essential to the standard.

6 9. Dialogic has directly infringed and continues to infringe one or more
7 claims of the '853 Patent under 35 U.S.C. § 271 by making, using, selling, offering
8 for sale, and/or importing products that support or utilize a system for coding
9 and/or decoding feature vectors of a signal according to the G.729B standard as
10 claimed in the '853 Patent, including, but not limited to, the Dialogic® I-Gate®
11 4000 Media Gateways and the Dialogic® I-Gate® 4000 SIP Gateway, and
12 reasonably similar products, which are advertised or otherwise indicated as being
13 compliant with the G.729B standard.

14 10. Dialogic received notice from AIM IP of the '853 Patent and a
15 number of products that are accused of infringing the '853 Patent by letter dated
16 December 20, 2010. Dialogic did not respond to AIM IP's December 20, 2010
17 letter, and there has been no indication that Dialogic has made any changes to its
18 accused products, or otherwise ceased its infringing activities, after it received
19 AIM IP's December 20, 2010 letter.

20 11. After Dialogic received notice of the '853 Patent and a number of
21 products that are accused of infringing the '853 Patent, Dialogic has knowingly
22 contributed to the infringement, and continues to contribute to infringement of one
23 or more of the claims of the '853 Patent by making and unlawfully selling or
24 offering to sell to customers products, including but not limited to the Dialogic® I-
25 Gate® 4000 Media Gateways and the Dialogic® I-Gate® 4000 SIP Gateway,
26 which constitute a material part of the invention and are not a staple article or
27 commodity of commerce suitable for substantial noninfringing use. Further, after
28 receiving notice of the '853 Patent, Dialogic has induced infringement, and

RUSS, AUGUST & KABAT

1 continues to induce infringement, of one or more of the claims of the '853 Patent
2 by making and unlawfully selling or offering to sell to customers products,
3 including without limitation the Dialogic® I-Gate® 4000 Media Gateways and the
4 Dialogic® I-Gate® 4000 SIP Gateway, with specific intent that these products be
5 used by Dialogic's customers to infringe the '853 Patent.

6 12. Dialogic's continuing use of the claimed invention after receiving
7 notice of the '853 Patent and a number of products that are accused of infringing
8 the '853 Patent by letter dated December 20, 2010 shows an intent to infringe or
9 cause others to infringe the '853 Patent. In addition, Dialogic is willfully
10 infringing the '853 Patent.

11 13. As a result of Dialogic's infringement of the '853 Patent, AIM IP has
12 suffered monetary damages in an amount not yet determined, and will continue to
13 suffer damages in the future unless Dialogic's infringing activities are enjoined by
14 this Court.

15 14. Dialogic's wrongful acts have damaged and will continue to damage
16 AIM IP irreparably, and AIM IP has no adequate remedy at law for those wrongs
17 and injuries. In addition to their actual damages, AIM IP is entitled to a
18 preliminary and permanent injunction restraining and enjoining Dialogic and its
19 agents, servants and employees, and all persons acting thereunder, in concert with,
20 or on their behalf, from infringing the '853 Patent.

21 **PRAYER FOR RELIEF**

22 WHEREFORE, AIM IP respectfully requests that this Court enter:

23 1. A judgment in favor of AIM IP that Dialogic has infringed, directly
24 and/or indirectly, by way of inducing and/or contributing to the infringement of the
25 '853 Patent;

26 2. An injunction enjoining Dialogic and its officers, directors, agents,
27 servants, affiliates, employees, divisions, branches, subsidiaries, parents, and all
28

RUSS, AUGUST & KABAT

1
2
3
4
5
6
7
8
9
10
11
12
13
14
15
16
17
18
19
20
21
22
23
24
25
26
27
28

others acting in concert or privity with any of them from infringing, inducing the infringement of, or contributing to the infringement of the '853 Patent;

3. A judgment and order requiring Dialogic to pay AIM IP its damages, costs, expenses, and prejudgment and post-judgment interest for Dialogic's infringement of the '853 Patent as provided under 35 U.S.C. § 284;

4. An award to AIM IP for enhanced damages, as provided under 35 U.S.C. § 284, resulting from the knowing, deliberate, and willful nature of Dialogic's prohibited conduct;

5. A judgment and order finding that this is an exceptional case within the meaning of 35 U.S.C. § 285 and awarding to AIM IP its reasonable attorneys' fees; and

6. Any and all other relief to which AIM IP may show itself to be entitled.

JURY TRIAL DEMANDED

AIM IP hereby demands a trial by jury of all issues so triable.

Respectfully submitted,

Dated: June 7, 2012

RUSS AUGUST & KABAT

By: 
Alexander C.D. Giza

Marc A. Fenster, State Bar No. 181067
Email: mfenster@raklaw.com
Alexander C.D. Giza, State Bar No. 212327
Email: agiza@raklaw.com
Fredricka Ung, State Bar No. 253794
Email: fung@raklaw.com
12424 Wilshire Boulevard, 12th Floor
Los Angeles, California 90025
Telephone: (310) 826-7474
Facsimile: (310) 826-6991

Attorneys for Plaintiff
AIM IP, LLC

RUSS, AUGUST & KABAT

- 1
- 2
- 3
- 4
- 5
- 6
- 7
- 8
- 9
- 10
- 11
- 12
- 13
- 14
- 15
- 16
- 17
- 18
- 19
- 20
- 21
- 22
- 23
- 24
- 25
- 26
- 27
- 28



US005920853A

United States Patent [19]

[11] **Patent Number:** 5,920,853

Benyassine et al.

[45] **Date of Patent:** Jul. 6, 1999

[54] **SIGNAL COMPRESSION USING INDEX MAPPING TECHNIQUE FOR THE SHARING OF QUANTIZATION TABLES**

5,506,801 4/1996 Tawel 364/807
 5,524,170 6/1996 Matsuo et al. 704/222
 5,592,227 1/1997 Feng 348/414
 5,619,717 4/1997 Staats 395/800.36

[75] **Inventors:** Adil Benyassine, Costa Mesa;
 Huan-Yu Su, San Clemente; Eyal Shlomot, Irvine, all of Calif.

Primary Examiner—Maria N. Von Buhr
Attorney, Agent, or Firm—Philip K. Yu

[73] **Assignee:** Rockwell International Corporation,
 Newport Beach, Calif.

[57] **ABSTRACT**

A signal compression system includes a coder and a decoder. The coder includes an extract unit for extracting an input feature vector from an input signal, a coder memory unit for storing a pre-designed vector quantization (VQ) table for the coder such that the coder memory unit uses a set of primary indices to address entries within the pre-designed VQ table, a coder mapping unit for mapping indices from a set of secondary indices to the first set of indices, and a search unit for searching for one index out of the set of secondary indices, wherein the index from the set of secondary indices corresponds to an entry in the coder memory unit, and the entry best represents the input feature vector according to some predetermined criteria. On the decoder side, the decoder includes a decoder memory unit for storing the same pre-designed VQ table and set of primary indices as the coder memory unit, a decoder mapping unit, and a retrieval unit, wherein the entry indicated by the index best represents the input feature vector.

[21] **Appl. No.:** 08/702,780

[22] **Filed:** Aug. 23, 1996

[51] **Int. Cl.⁶** G06F 17/30; G06F 5/00

[52] **U.S. Cl.** 707/1; 382/232; 382/253;
 704/222; 395/200.77

[58] **Field of Search** 395/2.09, 200.77;
 704/500, 222, 230; 707/1, 3; 348/384, 405,
 414, 417, 418, 422; 382/232, 253, 305

[56] **References Cited**

U.S. PATENT DOCUMENTS

4,963,030	10/1990	Makur	348/422
4,969,192	11/1990	Chen et al.	704/222
5,253,053	10/1993	Chu et al.	348/384
5,300,931	4/1994	Lindsay et al.	341/106
5,420,639	5/1995	Perkins	348/418

15 Claims, 13 Drawing Sheets

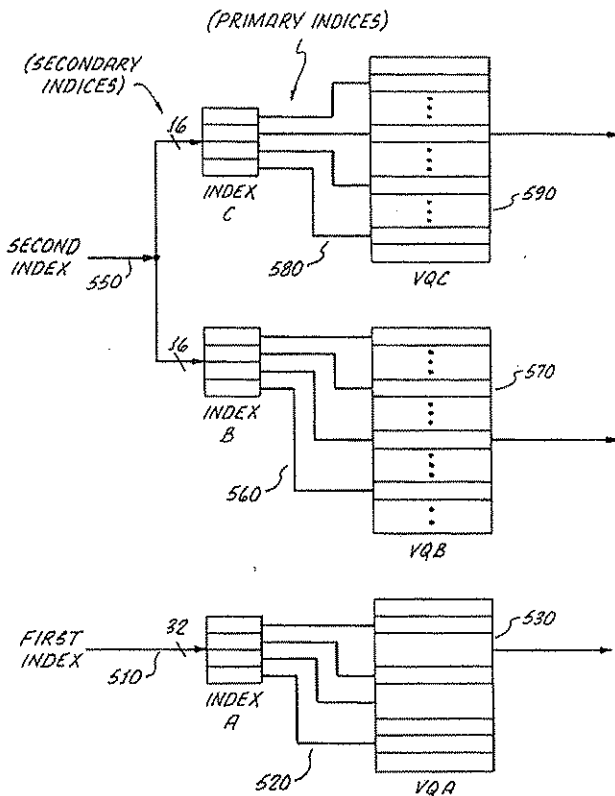

Ex. A

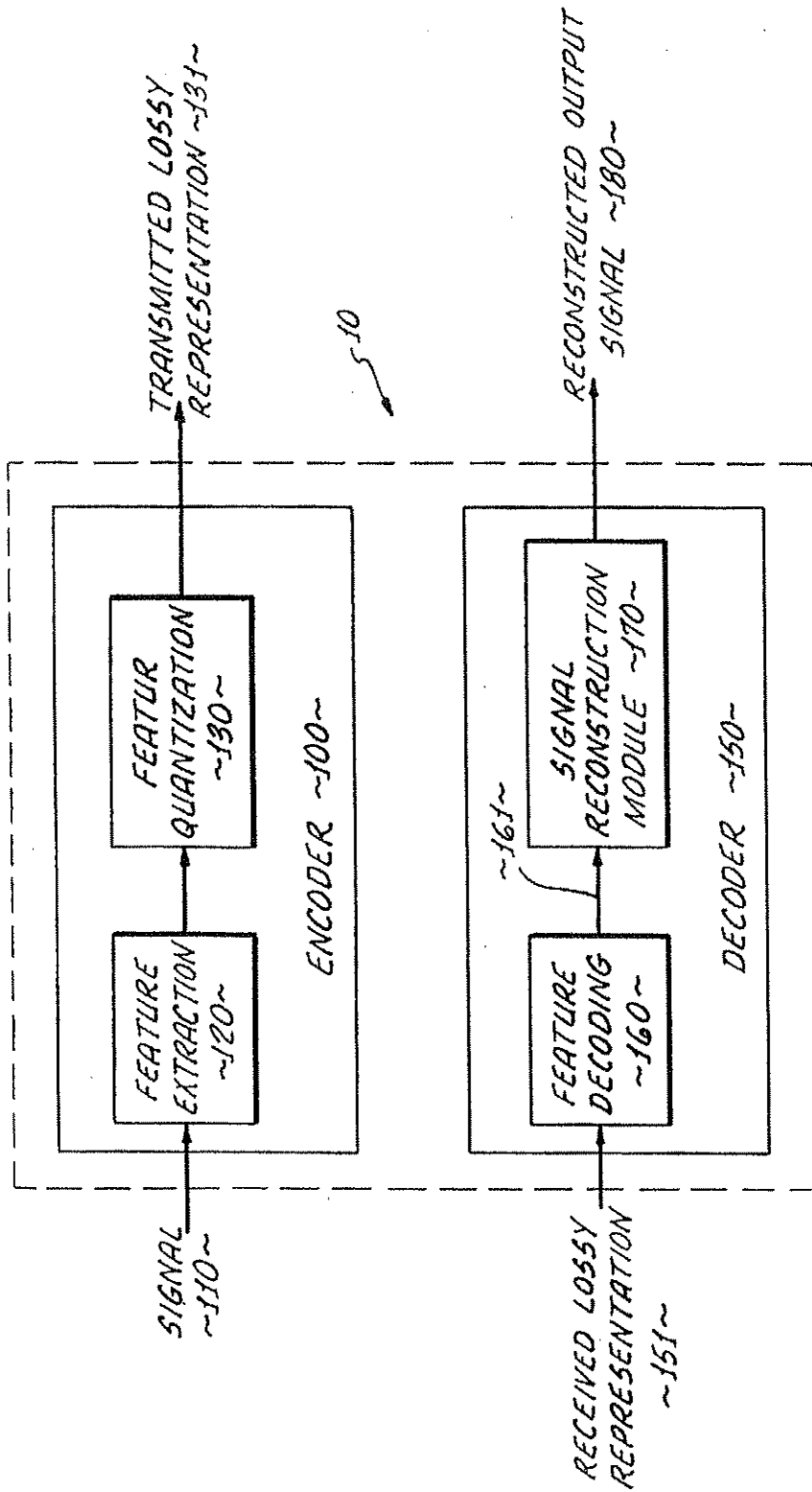

Figure 1 (Prior Art)

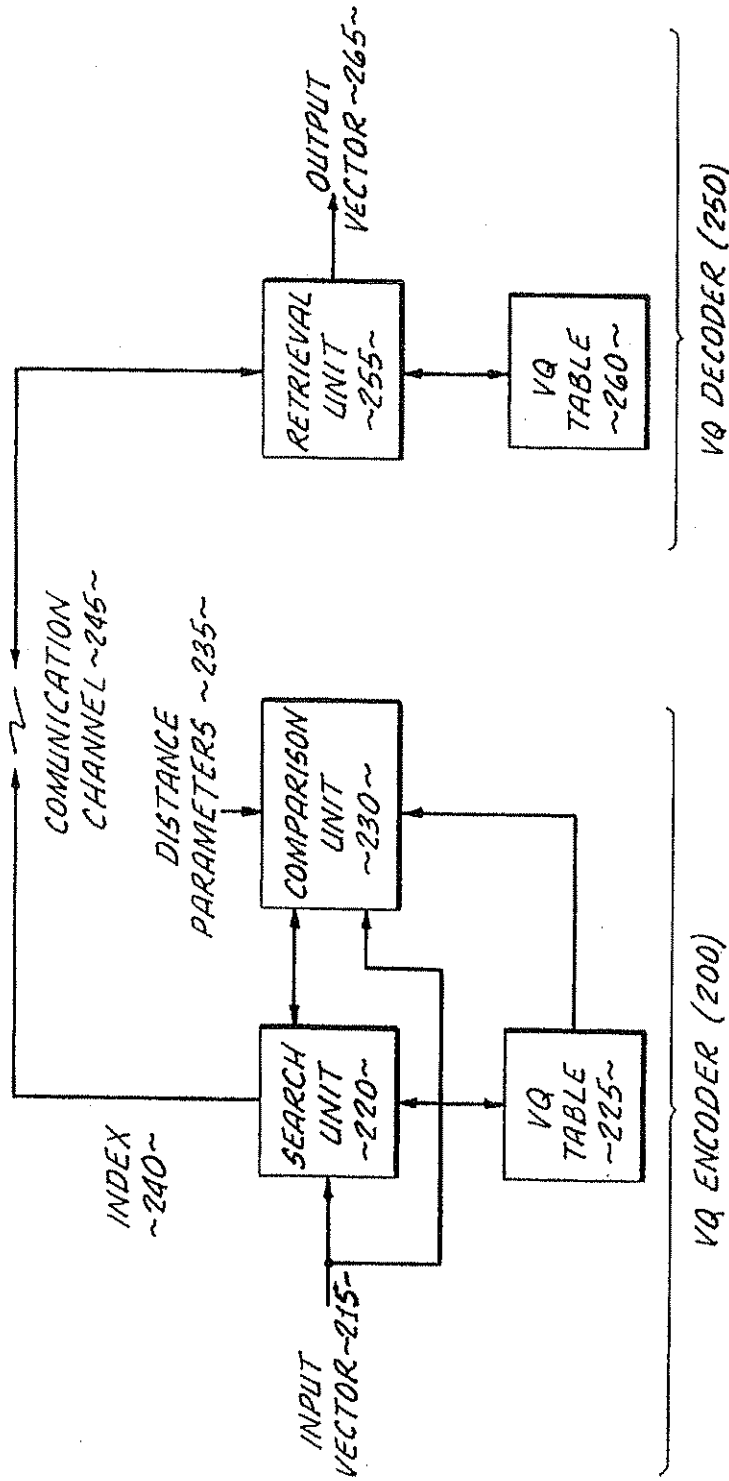

Figure 2 (Prior Art)

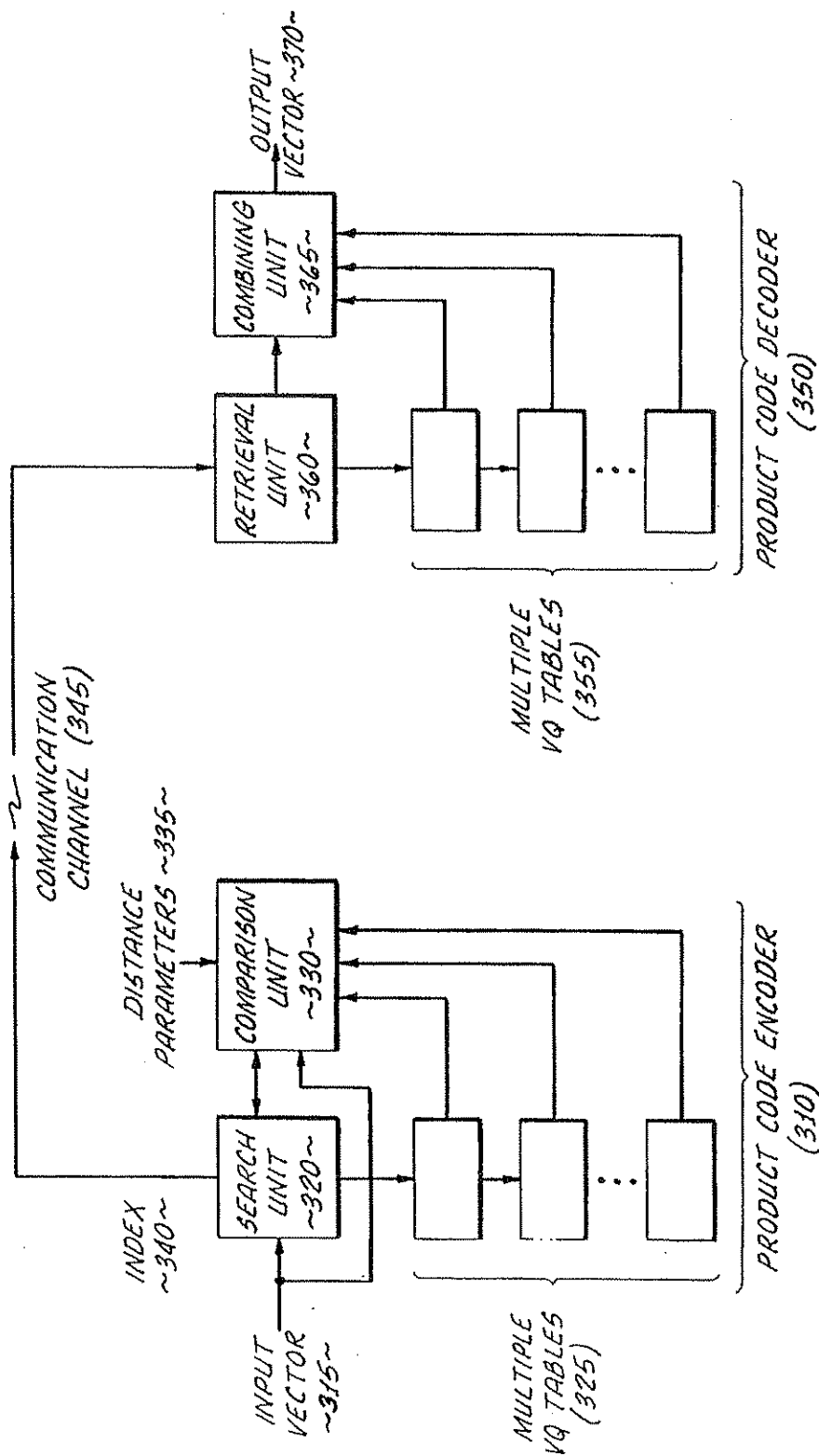

Figure 3 (Prior Art)

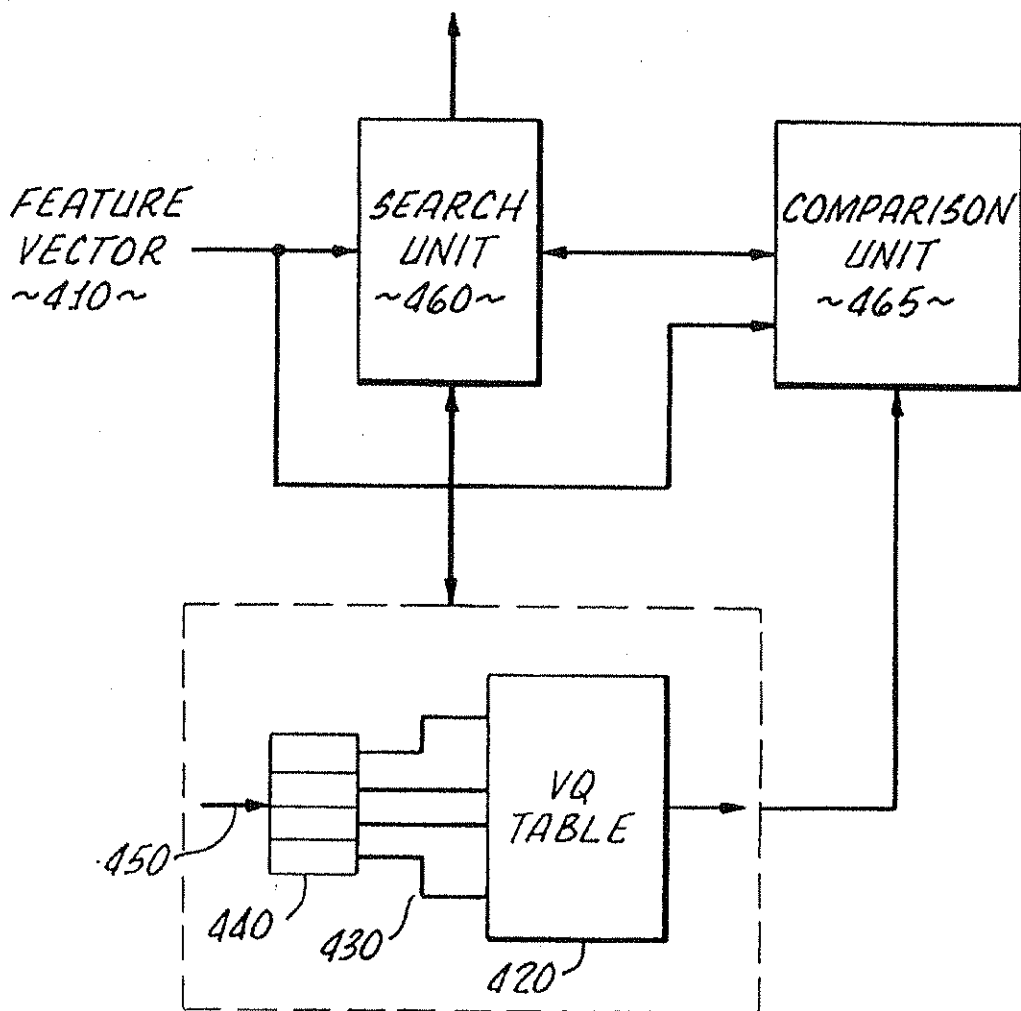

FIG. 4.

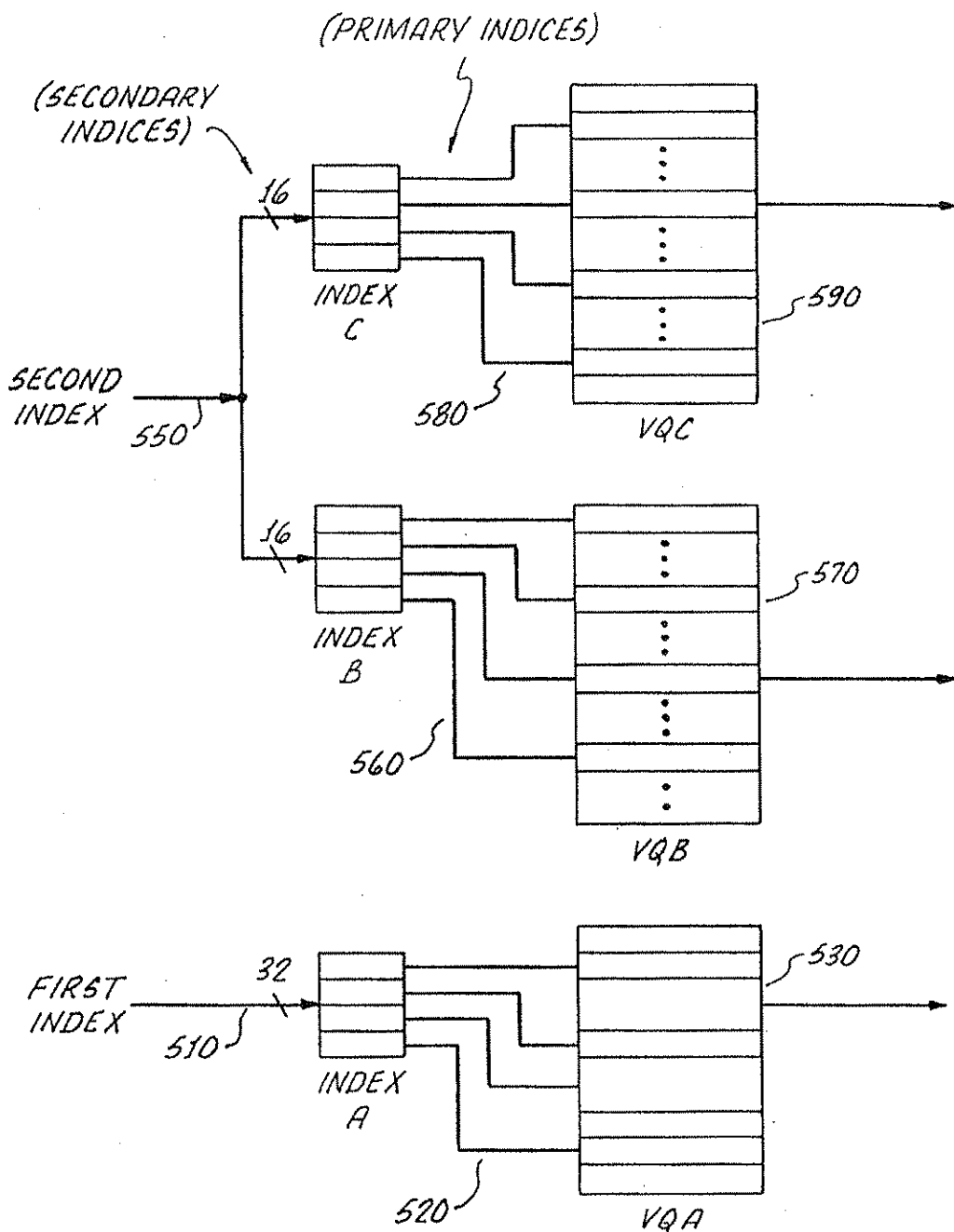

FIG. 5.

U.S. Patent

Jul. 6, 1999

Sheet 6 of 13

5,920,853

VQ Table 1:

1486	2168	3751	9074	12134	13944	17983	19173	21190	21820
1730	2640	3450	4870	6126	7876	15644	17817	20294	21902
1568	2256	3088	4874	11063	13393	18307	19293	21109	21741
1733	2512	3357	4708	6977	10296	17024	17956	19145	20350
1744	2436	3308	8731	10432	12007	15614	16639	21359	21913
1786	2369	3372	4521	6795	12963	17674	18988	20855	21640
1631	2433	3361	6328	10709	12013	13277	13904	19441	21088
1489	2364	3291	6250	9227	10403	13843	15278	17721	21451
1869	2533	3475	4365	9152	14513	15908	17022	20611	21411
2070	3025	4333	5854	7805	9231	10597	16047	20109	21834
1910	2673	3419	4261	11168	15111	16577	17591	19310	20265
1141	1815	2624	4623	6495	9588	13968	16428	19351	21286
2192	3171	4707	5808	10904	12500	14162	15664	21124	21789
1286	1907	2548	3453	9574	11964	15978	17344	19691	22495
1921	2720	4604	6684	11503	12992	14350	15262	16997	20791
2052	2759	3897	5246	6638	10267	15834	16814	18149	21675
1798	2497	5617	11449	13189	14711	17050	18195	20307	21182
1009	1647	2889	5709	9541	12354	15231	18494	20966	22033
3016	3794	5406	7469	12488	13984	15328	16334	19952	20791
2203	3040	3796	5442	11987	13512	14931	16370	17856	18803
2912	4292	7988	9572	11562	13244	14556	16529	20004	21073
2861	3607	5923	7034	9234	12054	13729	18056	20262	20974
3069	4311	5967	7367	11482	12699	14309	16233	18333	19172
2434	3661	4866	5798	10383	11722	13049	15668	18862	19831
2020	2605	3860	9241	13275	14644	16010	17099	19268	20251
1877	2809	3590	4707	11056	12441	15622	17168	18761	19907
2107	2873	3673	5799	13579	14687	15938	17077	18890	19831
1612	2284	2944	3572	8219	13959	15924	17239	18592	20117
2420	3156	6542	10215	12061	13534	15305	16452	18717	19880
1667	2612	3534	5237	10513	11696	12940	16798	18058	19378
2388	3017	4839	9333	11413	12730	15024	16248	17449	18677
1875	2786	4231	6320	8694	10149	11785	17013	18608	19960
679	1411	4654	8006	11446	13249	15763	18127	20361	21567
1838	2596	3578	4608	5650	11274	14355	15886	20579	21754
1303	1955	2395	3322	12023	13764	15883	18077	20180	21232
1438	2102	2663	3462	8328	10362	13763	17248	19732	22344
860	1904	6098	7775	9815	12007	14821	16709	19787	21132
1673	2723	3704	6125	7668	9447	13683	14443	20538	21731
1246	1849	2902	4508	7221	12710	14835	16314	19335	22720
1525	2260	3862	5659	7342	11748	13370	14442	18044	21334
1196	1846	3104	7063	10972	12905	14814	17037	19922	22636
2147	3106	4475	6511	8227	9765	10984	12161	18971	21300
1585	2405	2994	4036	11481	13177	14519	15431	19967	21275
1778	2688	3614	4680	9465	11064	12473	16320	19742	20800
1862	2586	3492	6719	11708	13012	14364	16128	19610	20425
1395	2156	2669	3386	10607	12125	13614	16705	18976	21367
1444	2117	3286	6233	9423	12981	14998	15853	17188	21857
2004	2895	3783	4897	6168	7297	12609	16445	19297	21465
1495	2863	6360	8100	11399	14271	15902	17711	20479	22061
2484	3114	5718	7097	8400	12616	14073	14847	20535	21396
2424	3277	5296	6284	11290	12903	16022	17508	19333	20283
2565	3778	5360	6989	8782	10428	14390	15742	17770	21734
2727	3384	6613	9254	10542	12236	14651	15687	20074	21102

Figure 6 (1 of 5)

Prior Art

U.S. Patent

Jul. 6, 1999

Sheet 7 of 13

5,920,853

1916	2953	6274	8088	9710	10925	12392	16434	20010	21183
3384	4366	5349	7667	11180	12605	13921	15324	19901	20754
3075	4283	5951	7619	9604	11010	12384	14006	20658	21497
1751	2455	5147	9966	11621	13176	14739	16470	20788	21756
1442	2188	3330	6813	8929	12135	14476	15306	19635	20544
2294	2895	4070	8035	12233	13416	14762	17367	18952	19688
1937	2659	4602	6697	9071	12863	14197	15230	16047	18877
2071	2663	4216	9445	10887	12292	13949	14909	19236	20341
1740	2491	3488	8138	9656	11153	13206	14688	20896	21907
2199	2881	4675	8527	10051	11408	14435	15463	17190	20597
1943	2988	4177	6039	7478	8536	14181	15551	17622	21579
1825	3175	7062	9818	12824	15450	18330	19856	21830	22412
2464	3046	4822	5977	7696	15398	16730	17646	20588	21320
2550	3393	5305	6920	10235	14083	18143	19195	20681	21336
3003	3799	5321	6437	7919	11643	15810	16846	18119	18980
3455	4157	6838	8199	9877	12314	15905	16826	19949	20892
3052	3769	4891	5810	6977	10126	14788	15990	19773	20904
3671	4356	5827	6997	8460	12084	14154	14939	19247	20423
2716	3684	5246	6686	8463	10001	12394	14131	16150	19776
1945	2638	4130	7995	14338	15576	17057	18206	20225	20997
2304	2928	4122	4824	5640	13139	15825	16938	20108	21054
1800	2516	3350	5219	13406	15948	17618	18540	20531	21252
1436	2224	2753	4546	9657	11245	15177	16317	17489	19135
2319	2899	4980	6936	8404	13489	15554	16281	20270	20911
2187	2919	4610	5875	7390	12556	14033	16794	20998	21769
2235	2923	5121	6259	8099	13589	15340	16340	17927	20159
1765	2638	3751	5730	7883	10108	13633	15419	16808	18574
3460	5741	9596	11742	14413	16080	18173	19090	20845	21601
3735	4426	6199	7363	9250	14489	16035	17026	19873	20876
3521	4778	6887	8680	12717	14322	15950	18050	20166	21145
2141	2968	6865	8051	10010	13159	14813	15861	17528	18655
4148	6128	9028	10871	12686	14005	15976	17208	19587	20595
4403	5367	6634	8371	10163	11599	14963	16331	17982	18768
4091	5386	6852	8770	11563	13290	15728	16930	19056	20102
2746	3625	5299	7504	10262	11432	13172	15490	16875	17514
2248	3556	8539	10590	12665	14696	16515	17824	20268	21247
1279	1960	3920	7793	10153	14753	16646	18139	20679	21466
2440	3475	6737	8654	12190	14588	17119	17925	19110	19979
1879	2514	4497	7572	10017	14948	16141	16897	18397	19376
2804	3688	7490	10086	11218	12711	16307	17470	20077	21126
2023	2682	3873	8268	10255	11645	15187	17102	18965	19788
2823	3605	5815	8595	10085	11469	16568	17462	18754	19876
2851	3681	5280	7648	9173	10338	14961	16148	17559	18474
1348	2645	5826	8785	10620	12831	16255	18319	21133	22586
2141	3036	4293	6082	7593	10629	17158	18033	21466	22084
1608	2375	3384	6878	9970	11227	16928	17650	20185	21120
2774	3616	5014	6557	7788	8959	17068	18302	19537	20542
1934	4813	6204	7212	8979	11665	15989	17811	20426	21703
2288	3507	5037	6841	8278	9638	15066	16481	21653	22214
2951	3771	4878	7578	9016	10298	14490	15242	20223	20990
3256	4791	6601	7521	8644	9707	13398	16078	19102	20249
1827	2614	3486	6039	12149	13823	16191	17282	21423	22041
1000	1704	3002	6335	8471	10500	14878	16979	20026	22427
1646	2286	3109	7245	11493	12791	16824	17667	18981	20222
1708	2501	3315	6737	8729	9924	16089	17097	18374	19917
2623	3510	4478	5645	9862	11115	15219	18067	19583	20382

Figure 6 (2 of 5)

Prior Art

U.S. Patent**Jul. 6, 1999****Sheet 8 of 13****5,920,853**

2518	3434	4728	6388	8082	9285	13162	18383	19819	20552
1726	2383	4090	6303	7805	12845	14612	17608	19269	20181
2860	3735	4838	6044	7254	8402	14031	16381	18037	19410
4247	5993	7952	9792	12342	14653	17527	18774	20831	21699
3502	4051	5680	6805	8146	11945	16649	17444	20390	21564
3151	4893	5899	7198	11418	13073	15124	17673	20520	21861
3960	4848	5926	7259	8811	10529	15661	16560	18196	20183
4499	6604	8036	9251	10804	12627	15880	17512	20020	21046
4251	5541	6654	8318	9900	11686	15100	17093	20572	21687
3769	5327	7865	9360	10684	11818	13660	15366	18733	19882
3083	3969	6248	8121	9798	10994	12393	13686	17888	19105
2731	4670	7063	9201	11346	13735	16875	18797	20787	22360
1187	2227	4737	7214	9622	12633	15404	17968	20262	23533
1911	2477	3915	10098	11616	12955	16223	17138	19270	20729
1764	2519	3887	6944	9150	12590	16258	16984	17924	18435
1400	3674	7131	8718	10688	12508	15708	17711	19720	21068
2322	3073	4287	8108	9407	10628	15862	16693	19714	21474
2630	3339	4758	8360	10274	11333	12880	17374	19221	19936
1721	2577	5553	7195	8651	10686	15069	16953	18703	19929

Figure 6 (3 of 5)**Prior Art**

U.S. Patent

Jul. 6, 1999

Sheet 9 of 13

5,920,853

VQ Table 2:

-435	-815	-742	1033	-518
-833	-891	463	-8	-1251
-1021	231	-306	321	-220
57	-198	-339	-33	-1468
171	-350	294	1660	453
-701	-842	-58	950	892
584	31	-289	356	-333
-109	-808	231	77	-87
-859	1236	550	854	714
-877	-954	-1248	-299	212
-77	344	-620	763	413
-314	-307	-256	-1260	-429
711	693	521	650	1305
-112	-271	-500	946	1733
575	-10	-468	-199	1101
145	-285	-1280	-398	36
-1133	-835	1350	1284	-95
-1459	-1237	416	-213	466
-15	66	468	1019	-748
-338	148	1445	75	-760
389	239	1568	981	113
-312	-98	949	31	1104
1127	584	835	277	-1159
539	-114	856	-493	223
2197	2337	1268	670	304
-1596	550	801	-456	-56
1154	593	-77	1237	-31
397	558	203	-797	-919
334	1475	632	-80	48
-545	-330	-429	-680	1133
1320	827	-398	-576	341
-163	674	-11	-886	531

Figure 6 (4 of 5)

Prior Art

U.S. Patent

Jul. 6, 1999

Sheet 10 of 13

5,920,853

VQ Table 3:

582	-1201	829	86	385
1450	72	-231	864	661
-163	-526	-754	-1633	267
573	796	-169	-631	816
519	291	159	-640	-1296
1549	715	527	-714	-193
-457	612	-283	-1381	-741
-344	1341	1087	-654	-569
-543	-1752	-195	-98	-276
-235	-728	949	1517	895
502	-362	-960	-483	1386
450	-466	-108	1010	2223
-28	-378	744	-1005	240
271	-15	909	-259	1688
-1011	581	-53	-747	878
-498	-1377	18	-444	1483
1015	-222	443	372	-354
669	659	1640	932	534
1385	-182	-907	-721	-262
569	1247	337	416	-121
369	-1003	-507	-587	-904
72	-141	1465	63	-785
208	301	-882	117	-404
-912	623	-76	276	-440
-267	-525	140	882	-139
-697	865	1060	413	446
581	-1037	-895	669	297
3	692	-292	1050	782
-1061	-484	362	-597	-852
-1182	-744	1340	262	63
-774	-483	-1247	-70	98
-1125	-265	-242	724	934

Figure 6 (5 of 5)

Prior Art

U.S. Patent

Jul. 6, 1999

Sheet 11 of 13

5,920,853

Mapping Unit 1

Secondary Index	Primary Index
0	96
1	52
2	20
3	54
4	86
5	114
6	82
7	68
8	36
9	121
10	48
11	92
12	18
13	120
14	94
15	124
16	50
17	125
18	4
19	100
20	28
21	76
22	12
23	117
24	81
25	22
26	90
27	116
28	127
29	21
30	108
31	66

Figure 7 (Sheet 1 of 3)

U.S. Patent

Jul. 6, 1999

Sheet 12 of 13

5,920,853

Mapping Unit 2

Secondary Index	Primary Index
0	31
1	21
2	9
3	3
4	10
5	2
6	19
7	26
8	4
9	3
10	11
11	29
12	15
13	27
14	21
15	12

Figure 7 (Sheet 2 of 3)

U.S. Patent

Jul. 6, 1999

Sheet 13 of 13

5,920,853

Mapping Unit 3

Secondary Index	Primary Index
0	16
1	1
2	0
3	0
4	8
5	25
6	22
7	20
8	19
9	23
10	20
11	31
12	4
13	31
14	20
15	31

Figure 7 (Sheet 3 of 3)

5,920,853

1

SIGNAL COMPRESSION USING INDEX MAPPING TECHNIQUE FOR THE SHARING OF QUANTIZATION TABLES

FIELD OF INVENTION

The present invention relates to data compression in communications systems and in particular to scalar and vector quantization in speech, audio and image coding using embedded design.

ART BACKGROUND

Modern communications systems rely heavily on data compression techniques for "lossy" coding of signals such as speech, audio, still images and video sequences. As can be understood by those skilled in the art, coding of signals can be done in either "lossy" or "lossless" methods, where lossy coding means that some distortion is introduced to the input signal by the coding system.

FIG. 1 depicts a general structure of a module (10) for signal compression and decompression in accordance with the present invention. The module (10) comprises an encoder (100) and a decoder (150). For data-receiving operations, only a decoder (150) is required. For data transmissions between two separate stations, the encoder and decoder should be provided at both the transmitting station and the receiving station. As a conceptual tool, compression will be described as occurring at the encoder (100) and decompression will be described as occurring at the decoder (150). In practical implementation, the encoder (100) and decoder (150) are contained in a single data module (10), which is implemented at both the transmitter station and receiver station.

The input signal (110) to the system is fed into the feature extraction unit (120) of the encoder (100). The extracted features are quantized by the feature quantization unit (130) and the resulting representation (131), which may include indices, is sent to the decoder (150). The features decoding unit (160) receives the lossy representation (151) and generates the lossy version (161) of the features from the lossy representation (151). The lossy version (161) is used by the signal reconstruction module (170) to produce the reconstructed output signal (180).

As can be understood from the description above, quantization methods play a major role in data compression. Quantization can be done on a single feature of the compressed signal, commonly called Scalar Quantization (SQ), or can be performed on a vector of features, commonly called Vector Quantization (VQ). Since a single feature can be regarded as a one-dimensional vector, SQ can be considered as a particular case of VQ. In the following description of this disclosure, the VQ schemes will be discussed. An example of speech coding algorithm which utilizes VQ as well as SQ is the recently adopted International Telecommunications Union (ITU) Recommendation G.729.

The concept of VQ is a well-established technique for signal compression. The technique can be generalized as follows. A table which holds a set of vectors, representing the signal (or some features of the signal), is first constructed. For each vector of the original signal (or a feature vector), the table is searched for the best representative entry in the table. The index of that entry is then stored or transmitted. Using the index as a pointer to an entry in the table, a lossy version of the original vector can be retrieved. The quantization table can be stored or can be represented according to some rule(s), such as a mapping scheme from an index to a vector.

2

FIG. 2 illustrates a typical structure of a VQ encoder (200) and a VQ decoder (250). The input vector (215) is presented to the search unit (220). The search unit (220) compares the input vector to each of the vectors stored in the VQ table (225), using the comparison unit (230). The comparison unit (230) compares the input vector to a vector in the table (225) using a distance measure which can also depend on a vector of distance parameters (235). The index (140) of the best representative vector is stored or transmitted to the VQ decoder (250) through a communications channel (245). The VQ decoder (250), including a retrieval unit (255), uses the index (240) to retrieve an entry from a copy (260) of the VQ table (225), which becomes the decoded output (265).

In some applications, the VQ table may be represented by a few smaller tables and a combining unit. The single index into the former larger table can be replaced with a few indices into these small tables. Upon retrieval, the entries from all the tables are combined into one output vector. Such VQ systems are commonly called "product code VQ."

The basic structure of a product code VQ is depicted in FIG. 3. A product code encoder (310) communicates with a product code decoder (350) (or "VQ decoder") via a communication channel (345) coupled to a retrieval unit (360). The input vector (315) is presented to the search unit (320). The search unit (320) compares the input vector to the entries in the multiple VQ tables (325), using the comparison unit (330). The comparison unit (330) compares the input vector to some combination of the vectors in the tables using a distance measure which can depend also on a vector of distance parameters (335). The indices (340) are stored or transmitted to the VQ decoder (350). The VQ decoder (350) uses the indices (340) to retrieve the entries from a copy (355) of the VQ table (325) and combine them using a combining unit (365). The combined vector becomes the decoded output (370).

Commonly, each signal compression scheme (such as a speech coding algorithm) uses specifically pre-designed quantization tables, which might be large and occupy a significant portion of the available memory.

However, in many practical applications, different compression schemes are used for the same signal. For example, different coding algorithms can be used for different rates in a variable-rate speech coding scheme. Hence, a method for sharing quantization tables in those cases is greatly desired. If all the schemes are designed at the same time, quantization tables can be shared by a technique called Constrained Storage VQ ("CSVQ"). However, if a new compression scheme is designed to work together with an already existing compression scheme, a new approach to the sharing of quantization tables is needed.

SUMMARY OF THE PRESENT INVENTION

A signal compression system is disclosed, which generally comprises a coder and a decoder. The coder comprises an extraction unit for extracting an input feature vector from an input signal, a coder memory unit for storing a pre-designed VQ table for the coder with the coder memory unit using a set of primary indices to address entries within the pre-designed VQ table, a coder mapping unit for mapping indices from a set of secondary indices to the set of primary indices with the set of secondary indices corresponding to a pre-selected subset of the pre-designed VQ table, a search unit for searching for one index out of the set of secondary indices with the index from the set of secondary indices corresponding to an entry in the coder memory unit, wherein the entry best represents the input feature vector according

5,920,853

3

to some predetermined criteria. The index from the set of secondary indices can then be transmitted through a communications channel.

On the decoder side, the decoder comprises a decoder memory unit for storing the same pre-designed VQ table as the coder memory unit with the decoder memory unit also using the set of primary indices to address entries within the pre-designed VQ table, a decoder mapping unit for mapping the one index from the set of secondary indices to one index from the set of primary indices, a retrieval unit for retrieving an entry from the decoder memory unit by mapping the one index from the set of primary indices to an entry from the decoder memory unit, wherein the entry best represents the input feature vector.

The index mapping approach in accordance with the present invention can be applied to address the problem of spectral quantization for speech signals, as well as spectral quantization of the background noise presented during silence periods. In many speech communications systems, the pre-designed VQ table (420) is designed for a faithful representation of the speech spectrum. However, the background noise during silence periods can be faithfully represented using a smaller number of bits and smaller quantization tables. A subset of the tables used for speech spectral quantization can be chosen to represent the spectrum of the background noise, and the index mapping technique described above can be used to represent this subset. Further, different search units and comparison units can be used for speech spectral quantization and for background noise spectral quantization.

BRIEF DESCRIPTION OF THE DRAWINGS

FIG. 1 depicts a typical structure of a module for signal compression and decompression using VQ quantization.

FIG. 2 depicts a typical structure of a VQ encoder and a VQ decoder.

FIG. 3 depicts a basic structure of a product code VQ.

FIG. 4 depicts a generalized structure of the index mapping system in accordance with the present invention.

FIG. 5 depicts a generalize structure of multiple index mapping system in accordance with the present invention.

FIG. 6 lists the three (3) pre-designed VQ tables in accordance with the ITU Recommendations G.729/G.729A.

FIG. 7 lists the three (3) index mapping units for the three (3) VQ tables in accordance with the present invention.

DETAILED DESCRIPTION OF THE PREFERRED EMBODIMENT

An efficient data compression and decompression system using VQ for a communications system is disclosed. In the following description, numerous specific details are set forth, such as tables, indices, or memory sizes, in order to provide a thorough understanding of the present invention. It should be understood, however, by those skilled in the art that these details are not required to practice the present invention. In other instances, well known circuits, methods and the like are not set forth in detail to avoid unnecessarily obscuring the present invention.

In any speech coding system, the quantization of the speech spectrum requires a substantial number of bits for its faithful representation in order to cover the wide range of speech spectra. However, a background acoustic noise is almost always present during typical speech communications in a car, in an office or on the street. The spectrum of the background noise has a much smaller dynamic range

4

than that of speech communications, and thus requires much fewer number of bits for its faithful representation. Therefore, the usage of the conventional quantization scheme for the speech spectrum in order to quantize the background noise spectrum has become redundant due to the number of bits required.

A possible solution to the above-described problem is to have a different representation for the spectrum of the background noise. This representation may also be of the form of tables which have smaller sizes than the ones used for speech, due to the considerably fewer number of bits needed for the spectrum representation of the background noise. However, this approach ends up requiring a substantial increase in memory storage for the new tables, as can be appreciated by those skilled in the art.

A further improved approach to the above-described problem is to use a reduced version of the existing tables, which represent the speech spectrum, for the representation of the background noise spectrum. To that end, an auxiliary look-up table of an extremely small memory storage requirement can be designed. This auxiliary table uses indices of the pre-selected useful entries from the speech spectrum tables. As can be appreciated by those skilled in the art, this approach will result in a much less complex system, as well as fewer number of bits for representing the background noise.

With the above described system in mind, the data compression system in accordance with the present invention uses a scheme of index mapping, which can be implemented using a table of look-up pointers, for sharing quantization tables. The basic structure of an index mapping system is described in FIG. 4. A feature vector (410) has to be quantized by a pre-designed VQ table (420). However, only a predetermined subset of the entries of the pre-designed VQ table (420) needs to be used for the quantization of the feature vector (410). This pre-determined subset of the entries is defined by its set of primary indices (430) into the quantization table (420). The set of primary indices (430) is generated by a mapping unit (440) from a set of secondary indices (450). A search unit (460) runs over all the indices in the set of secondary indices (450), each defining a unique entry in the VQ table (420) by the index mapping unit (440), and chooses the entry from the pre-determined subset of the entries which best represents the features vector according to a predetermined set of criteria, through the comparison unit (465). The indices from the set of secondary indices (450) are now describing the "lossy" representation (131) of the features vector (410) and transmitted to by a decoder (150) of FIG. 1.

The index mapping technique described above can be extended to include a multiplicity of pre-designed VQ tables and a multiplicity of index mapping units for the implementation of various product code VQ systems (as in FIG. 3). Note that in FIG. 3, each VQ table (325, 355) can be implemented by a unique pair of index mapping unit and a pre-designed VQ table such as index 440 and table 420 in FIG. 4.

The index mapping approach in accordance with the present invention may be further applied to address the problem of spectral quantization for speech signals, as well as spectral quantization of the background noise presented during silence periods. In many speech communications systems, the pre-designed VQ table (420) is designed for a faithful representation of the speech spectrum. Similarly, the background noise during silence periods can also be faithfully represented using smaller number of bits and smaller

5,920,853

5

quantization tables. A subset of the tables used for speech spectral quantization can be chosen to represent the spectrum of the background noise, and the index mapping technique described above can be used to represent this subset. As should be noted, different search units and comparison units can be used for speech spectral quantization and for background noise spectral quantization.

A 3-table product code VQ with 128, 32, and 32 entries is used for spectral quantization of speech signals in the ITU Recommendations G.729 and Annex A of Recommendations G.729 ("G.729A"). The 3-table product code VQ according to the Recommendations is listed in FIG. 6. However, as contributed by Assignee of the present invention, for the quantization of the background noise in Recommendations G.729B, only 32, 16 and 16 entries, respectively, out of the 3 VQ tables are needed. The 3 mapping units for the 3 VQ tables in accordance with the present invention are listed in FIG. 7. The contents of ITU Recommendations G.729, G.729A and G.729B ("Coding of Speech at 8 kbit/s Using Conjugate-Structured Algebraic-Code-Excited Linear-Prediction" and its Annexes A and B) are hereby incorporated by reference.

FIG. 5 depicts an index mapping system for the quantization of the background noise according to the ITU Recommendations G.729B. Two indices are used to describe the entries in the VQ tables. The first index (510) is mapped by the first index mapping module (520) into the first VQ table (530). The second index (550) is mapped by the second index mapping module (560) into the second VQ table (570) and is also mapped by the third index mapping module (580) into the third VQ table (590).

From the above description, a methodology for sharing quantization tables between different data compression schemes have been disclosed. The methodology uses index mapping technique into existing quantization tables for table space reduction and memory saving. In particular, the methodology according to the present invention allows for sharing spectral quantization tables between Recommendations G.729/G.729A and G.729B.

Although only a few exemplary embodiments of this invention have been described in detail above, those skilled in the art will readily appreciate that many modifications are possible in the exemplary embodiments without materially departing from the novel teachings and advantages of this invention. Accordingly, all such modifications are intended to be included within the scope of this invention as defined in the following claims. In the claims, means-plus-function clauses are intended to cover the structures described herein as performing the recited function and not only structural equivalents but also equivalent structures. Thus although a nail and a screw may not be structural equivalents in that a nail employs a cylindrical surface to secure wooden parts together, whereas a screw employs a helical surface, in the environment of fastening wooden parts, a nail and a screw may be equivalent structures.

We claim:

1. A system for coding and decoding feature vectors of a signal transmitted through a communications channel, comprising a coder and a decoder, wherein:

a) the coder comprises:

extraction means for extracting an input feature vector from the signal;

coder memory means for storing one pre-designed VQ table for the coder, the coder memory means using a set of primary indices to address entries within the pre-designed VQ table;

6

coder mapping unit for mapping indices from a set of fixed length secondary indices to the set of primary indices, the set of secondary indices corresponding to one pre-selected subset of the pre-designed VQ table; search means coupled to the coder mapping unit for searching for one index out of the set of secondary indices, wherein the one index from the set of secondary indices corresponds to one index from the set of primary indices which corresponds to an entry in the coder memory means, wherein the entry in the coder memory means which best represents the input feature vector according to predetermined criteria;

b) the decoder comprises:

decoder memory means for storing the same at least one pre-designed VQ table as stored by the coder memory means, the decoder memory means also using the set of primary indices to address entries within the pre-designed VQ table;

decoder mapping unit for mapping the one index from the set of secondary indices to one index from the set of primary indices;

retrieval means for retrieving an entry from the decoder memory means by mapping the one index from the set of primary indices as mapped by the decoder mapping unit to one entry from the decoder memory means, wherein the entry best represents the input feature vector.

2. A system according to claim 1, wherein:

the coder mapping unit comprises a lookup table; and the decoder mapping unit comprises a lookup table.

3. A coder for coding feature vectors of a signal for processing, comprising:

extraction means for extracting an input feature vector from the signal;

coder memory means for storing one pre-designed VQ table for the coder, the coder memory means using a set of primary indices to address entries within the pre-designed VQ table;

coder mapping unit for mapping indices from a set of fixed length secondary indices to the set of primary indices, the set of secondary indices corresponding to one pre-selected subset of the pre-designed VQ table;

search means coupled to the coder mapping unit for searching for one index out of the set of secondary indices, wherein the one index from the set of secondary indices corresponds to one index from the set of primary indices which corresponds to an entry in the coder memory means, wherein the entry in the coder memory means best represents the input feature vector according to predetermined criteria to an entry in the coder memory means which best represents the input feature vector according to predetermined criteria.

4. A decoder for decoding a feature vector of a signal received from a coder having a pre-designed VQ table, a set of primary indices, and a set of fixed length secondary indices associated therewith, said decoder comprising:

decoder memory means for storing the pre-designed VQ table and a pre-selected subset of the pre-designed VQ table associated with the set of secondary indices, wherein the decoder memory means uses the set of primary indices to address entries within the pre-designed VQ table;

decoder mapping unit for mapping an index from the set of secondary indices to an index from the set of primary indices;

5,920,853

7

retrieval means for retrieving an entry from the decoder memory means by mapping the index from the set of primary indices as mapped by the decoder mapping unit to an entry from the decoder memory means, wherein the entry best represents the feature vector.

5. A system for coding and decoding feature vectors of a signal transmitted through a communications channel, comprising a coder and a decoder, wherein:

a) the coder comprises:

extraction means for extracting an input feature vector from the signal;

coder memory means for storing at least one pre-designed VQ table for the coder, the coder memory means using at least one set of primary indices to address entries within the at least one pre-designed VQ table;

at least one coder mapping unit for mapping indices from at least one set of fixed length secondary indices to the at least one set of primary indices, the at least one set of secondary indices corresponding to at least one pre-selected subset of the pre-designed VQ table;

search means coupled to the coder mapping means for searching for at least one index out of the at least one set of secondary indices, wherein the at least one index from the at least one set of secondary indices corresponds to at least one index from the at least one set of primary indices which corresponds to at least one entry in the coder memory means, wherein the at least one entry in the coder memory means best represents the input feature vector according to predetermined criteria to at least one entry in the coder memory means which best represents to the input feature vector according to predetermined criteria;

b) the decoder comprises:

decoder memory means for storing at least one pre-designed VQ table which is the same as stored by the coder memory means, the decoder memory means also using at least one set of primary indices to address entries within the at least one pre-designed VQ table;

decoder mapping unit for mapping the at least one index from the at least one set of secondary indices to the at least one set of primary indices;

retrieval means for retrieving at least one entry from the decoder memory means by mapping the at least one index from the at least one set of primary indices as mapped by the decoder mapping unit to at least one entry from the decoder memory means, wherein the at least one entry best represents the input feature vector.

6. A coder for coding feature vectors of a signal, comprising:

extraction means for extracting an input feature vector from the signal;

coder memory means for storing at least one pre-designed VQ table for the coder, the coder memory means using at least one set of primary indices to address entries within the at least one pre-designed VQ table;

at least one coder mapping unit for mapping indices from at least one set of fixed length secondary indices to the at least one set of primary indices, the at least one set of secondary indices corresponding to at least one pre-selected subset of the pre-designed VQ table;

search means coupled to the coder mapping means for searching for at least one index out of the at least one set of secondary indices, wherein the at least one index corresponds to at least one index from the at least one set of primary indices which corresponds to at least one

8

entry in the coder memory means, wherein the at least one entry in the coder memory means best represents the input feature vector according to predetermined criteria to at least one entry in the coder memory means which best represents to the input feature vector according to predetermined criteria.

7. A decoder for decoding a feature vector of a signal, which is coded by a coder comprising coder memory means with at least one pre-designed VQ table, said decoder comprising:

decoder memory means for storing said at least one pre-designed VQ table and a pre-selected subset of the pre-designed VQ table associated with a set of fixed length secondary indices, wherein the decoder memory means uses at least one set of primary indices to address entries within the at least one pre-designed VQ table;

decoder mapping unit for mapping at least one index from the set of secondary indices to the at least one set of primary indices;

retrieval means for retrieving at least one entry from the decoder memory means by mapping the at least one index as mapped by the decoder mapping unit to at least one entry from the decoder memory means, wherein the at least one entry best represents the feature vector.

8. A coder for coding feature vectors of a signal, comprising:

extraction means for extracting an input feature vector from the signal;

coder memory means for storing first, second and third pre-designed VQ tables for the coder, the coder memory means using first, second and third sets of primary indices to address entries within the first, second and third pre-designed VQ tables, respectively;

three (3) coder mapping units for mapping indices from a first set of fixed length secondary indices to the first set of primary indices and from a second set of fixed length secondary indices to the second and third sets of primary indices, wherein the first and second sets of secondary indices correspond to 3 subsets of the first, second and third sets of primary indices of the first, second and third pre-designed VQ tables, respectively;

search means coupled to the 3 coder mapping units for searching for 2 secondary indices out of the first and second sets of secondary indices, wherein each of the 2 secondary indices from the first and second sets of secondary indices corresponds to 3 indices from the first, second and third sets of primary indices which correspond to 3 entries in the coder memory means' 3 pre-designed VQ tables, wherein the 3 entries best represent the input feature vector according to predetermined criteria.

9. The system according to claim 8, wherein the 3 coder mapping units are implemented using first, second and third lookup tables, wherein:

first lookup table comprises: {96, 52, 20, 54, 86, 114, 82, 68, 36, 121, 48, 92, 18, 120, 94, 124, 50, 125, 4, 100, 28, 76, 12, 117, 81, 22, 90, 116, 127, 21, 108, 66};

second lookup table comprises: {31, 21, 9, 3, 10, 2, 19, 26, 4, 3, 11, 29, 15, 27, 21, 12}; and

third lookup table comprises: {16, 1, 0, 0, 8, 25, 22, 20, 19, 23, 20, 31, 4, 31, 20, 31}.

10. The system according to claim 8, wherein the 3 coder mapping units comprise:

first means for generating a mapping from a secondary index to a primary index in accordance with a first set

5,920,853

9

of ordered pairs of secondary and primary indices respectfully, comprising: {0,96}, {1,52}, {2,20}, {3,54}, {4,86}, {5,114}, {6,82}, {7,68}, {8,36}, {9,121}, {10,48}, {11, 92}, {12,18}, {13,120}, {14, 94}, {15,124}, {16,50}, {17,125}, {18,4}, {19,100}, {20,28}, {21,76}, {22,12}, {23,117}, {24,81}, {25, 22}, {26,90}, {27,116}, {28,127}, {29,21}, {30, 108}, {31,66};

second means for generating a mapping from a secondary index to a primary index in accordance with a second set of ordered pairs of secondary and primary indices respectively, comprising: {0,31}, {1,21}, {2,9}, {3,3}, {4,10}, {5,2}, {6,19}, {7,26}, {8,4}, {9,3}, {10,11}, {11,29}, {12,15}, {13,27}, {14,21}, {15,12};

third means for generating a mapping from a secondary index to a primary index in accordance with a third set of ordered pairs of secondary and primary indices respectively, comprising: {0,16}, {1,1}, {2,0}, {3,0}, {4,8}, {5,25}, {6,22}, {7,20}, {8,19}, {9,23}, {10,20}, {11,31}, {12,4}, {13,31}, {14,20}, {15,31}.

11. A decoder for decoding a feature vector of a coded signal based on a first and second set of fixed length secondary indices, wherein the coded signal has been coded by a coder with first, second and third pre-designed VQ tables, comprising:

means for receiving the first and second secondary indices;

decoder memory means for storing the first, second and third pre-designed VQ tables which are the same VQ tables as stored by the coder, the decoder memory means using first, second and third sets of primary indices to address entries within the first, second and third pre-designed VQ tables;

three (3) decoder mapping units for mapping the first secondary index to a first primary index out of the first set of primary indices, and mapping the second secondary index to second and third primary indices out of the second and third sets of primary indices;

retrieval means for retrieving 3 entries from the decoder memory means by mapping the first, secondary and third primary indices as mapped by the three decoder mapping units to 3 entries from the decoder memory means, wherein the 3 entries best represent the feature vector.

12. A system for coding and decoding feature vectors of a signal transmitted through a communications channel, comprising a coder and a decoder, wherein:

a) the coder comprises:

extraction means for extracting an input feature vector from the signal;

coder memory means for storing first, second and third pre-designed VQ tables for the coder, the coder memory means using first, second and third sets of primary indices to address entries within the first, second and third pre-designed VQ tables, respectively;

three (3) coder mapping units for mapping indices from a first set of fixed-length secondary indices to the first set of primary indices and from a second set of fixed-length secondary indices to the second and third sets of primary indices, the first and second sets of secondary indices corresponding to 3 subsets of the first, second and third sets of primary indices of the first, second and third pre-designed VQ tables, respectively;

search means coupled to the 3 coder mapping units for searching for 2 secondary indices out of the first and second sets of secondary indices, wherein each of the

10

2 secondary indices from the first and second sets of secondary indices corresponds to 3 entries from the first, second and third set of primary indices, wherein the 3 entries best represent the input feature vector according to predetermined criteria; and

b) the decoder comprises:

means for receiving the first and second secondary indices;

decoder memory means for storing the first, second and third pre-designed VQ tables, the decoder memory means using first, second and third sets of primary indices to address entries within the first, second and third pre-designed VQ tables;

three (3) decoder mapping units for mapping the first secondary index to a first primary index out of the first set of primary indices, and mapping the second secondary index to second and third primary indices out of the second and third sets of primary indices;

retrieval means for retrieving 3 entries from the decoder memory means by mapping the first, second and third primary indices as mapped by the three decoder mapping units to 3 entries from the decoder memory means, wherein the 3 entries best represent the input feature vector.

13. The system according to claim 12, wherein said signal comprises an encoded speech signal comprising a speech period and a silence period, and wherein said speech period is encoded in accordance with said three pre-designed VQ tables, and said silence period is encoded in defined with said first and second set of secondary indices.

14. The system according to claim 12, wherein the 3 coder mapping units are implemented using first, second and third lookup tables, wherein:

first lookup table comprises: {96, 52, 20, 54, 86, 114, 82, 68, 36, 121, 48, 92, 18, 120, 94, 124, 50, 125, 4, 100, 28, 76, 12, 117, 81, 22, 90, 116, 127, 21, 108, 66};

second lookup table comprises: {31, 21, 9, 3, 10, 2, 19, 26, 4, 3, 11, 29, 15, 27, 21, 12}; and

third lookup table comprises: {16, 1, 0, 0, 8, 25, 22, 20, 19, 23, 20, 31, 4, 31, 20, 31}.

15. The system according to claim 12, wherein the 3 coder mapping units comprise:

first means for generating a mapping from a secondary index to a primary index in accordance with a first set of ordered pairs of secondary and primary indices respectfully, comprising: {0,96}, {1,52}, {2,20}, {3,54}, {4,86}, {5,114}, {6,82}, {7,68}, {8,36}, {9,121}, {10,48}, {11, 92}, {12,18}, {13,120}, {14,94}, {15,124}, {16,50}, {17,125}, {18,4}, {19,100}, {20, 28}, {21,76}, {22,12}, {23,117}, {24,81}, {25,22}, {26,90}, {27,116}, {28,127}, {29,21}, {30, 108}, {31, 66};

second means for generating a mapping from a secondary index to a primary index in accordance with a second set of ordered pairs of secondary and primary indices respectively, comprising: {0,31}, {1,21}, {2,9}, {3,3}, {4,10}, {5,2}, {6,19}, {7,26}, {8,4}, {9,2}, {10,11}, {11,29}, {12,15}, {13,27}, {14,21}, {15,12};

third means for generating a mapping from a secondary index to a primary index in accordance with a third set of ordered pairs of secondary and primary indices respectively, comprising: {0,16}, {1,1}, {2,0}, {3,0}, {4,8}, {5,25}, {6,22}, {7,20}, {8,19}, {9,23}, {10,20}, {11,31}, {12,4}, {13,31}, {14,20}, {15,31}.

* * * * *

UNITED STATES PATENT AND TRADEMARK OFFICE
CERTIFICATE OF CORRECTION

PATENT NO. : 5,920,853
APPLICATION NO. : 08/702780
DATED : July 6, 1999
INVENTOR(S) : Benyassine et al.

Page 1 of 1

It is certified that error appears in the above-identified patent and that said Letters Patent is hereby corrected as shown below:

In the claims, column 6, lines 52-54, delete "to an entry in the coder memory means which best represents the input feature vector according to predetermined criteria."

In the claims, column 7, lines 31-33, delete "to at least one entry in the coder memory means which best represents the input feature vector according to predetermined criteria."

In the claims, column 8, lines 4-6, delete "to at least one entry in the coder memory means which best represents the input feature vector according to predetermined criteria."

Signed and Sealed this

Twenty-fourth Day of August, 2010

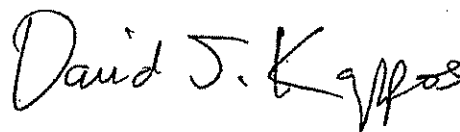

David J. Kappos
Director of the United States Patent and Trademark Office