

**IN THE UNITED STATES DISTRICT COURT
FOR THE DISTRICT OF DELAWARE**

| | | |
|-------------------------|---|----------------------------|
| SAFE STORAGE LLC, |) | |
| |) | |
| Plaintiff, |) | Civil Action No. _____ |
| |) | |
| v. |) | |
| |) | JURY TRIAL DEMANDED |
| DOT HILL SYSTEMS CORP., |) | |
| |) | |
| Defendant. |) | |

COMPLAINT FOR PATENT INFRINGEMENT

This is an action for patent infringement in which Plaintiff Safe Storage LLC (“Safe Storage”) makes the following allegations against Defendant Dot Hill Systems Corp. (“Defendant”):

PARTIES

1. Plaintiff Safe Storage LLC is a Delaware limited liability company.
2. On information and belief, Defendant Dot Hill Systems Corp. is a Delaware corporation with its principal office at 1351 S. Sunset Street, Longmont, CO 80501. Defendant has appointed United Corporate Services, Inc., 874 Walker Rd., Ste C, Dover, DE 19904, as its agent for service of process.

JURISDICTION AND VENUE

3. This action arises under the patent laws of the United States, 35 U.S.C. § 1, *et seq.*, including § 271. This Court has subject matter jurisdiction pursuant to 28 U.S.C. §§ 1331 and 1338(a).
4. This Court has personal jurisdiction over Defendant because, among other reasons, Defendant is incorporated under the laws of the State of Delaware, has done business in this District, has committed and continues to commit acts of patent infringement in this District,

and has harmed and continues to harm Safe Storage in this District, by, among other things, using, selling, offering for sale, and importing infringing products and services in this District.

5. Venue is proper in this District under 28 U.S.C. §§ 1391(b)-(c) and 1400(b) because, among other reasons, Defendant is subject to personal jurisdiction in this District, and has committed and continues to commit acts of patent infringement in this District. On information and belief, for example, Defendant has used, sold, offered for sale, and imported infringing products in this District.

COUNT I
INFRINGEMENT OF U.S. PATENT NO. 6,978,346

6. United States Patent No. 6,978,346 (“the Safe Storage Patent” or “the ’346 Patent”) was invented by Sung-Hoon Baek, Joong-Bae Kim, and Yong-Youn Kim of the Electronics and Telecommunications Research Institute (“ETRI”). ETRI is the national leader in Korea in the research and development of information technologies. Since its inception in 1976, ETRI has developed new technologies in 4M DRAM computer memory, CDMA and 4G LTE cellular phone communications, LCD displays, as well as large-scale computer storage, the technology at issue in this case. ETRI employs over 1730 research/technical staff, of whom 93% hold a post-graduate degrees and 41% have earned a doctoral degree in their technological field. Over the last five years, ETRI has applied for a total of 18,639 patents, has contributed 7,548 proposals that have been adopted by international and domestic standard organizations, and has published over 1,300 articles in peer-reviewed technology publications.

7. Safe Storage is the exclusive licensee of the ’346 Patent entitled “Apparatus for redundant interconnection between multiple hosts and RAID” (“Redundant Array of Inexpensive Disks”). The application for the ’346 Patent was filed on December 29, 2000, with a priority date of at least September 19, 2000. The patent issued on December 20, 2005. Pursuant to Safe

Storage's exclusive license, Safe Storage has all substantial rights regarding the '346 Patent, including the exclusive right to bring suit for infringement of the '346 Patent. A true and correct copy of the Safe Storage Patent is attached as Exhibit A.

8. The Safe Storage Patent claims, *inter alia*, an apparatus for a redundant interconnection between multiple hosts and a RAID, comprising: a first RAID controlling unit and a second RAID controlling unit for processing a requirement of numerous host computers, the first RAID controlling unit including a first network controlling unit and a second network controlling unit, and the second RAID controlling unit including a third network controlling unit and a fourth network controlling unit; and a plurality of connection units for connecting the first RAID controlling units and the second RAID controlling unit to the numerous host computers, wherein the first RAID controlling unit and the second RAID controlling unit directly exchange information with the numerous host computers through the plurality of connecting units, and the first network controlling unit exchanges information with the fourth network controlling unit, and the second network controlling unit exchanges information with the third network controlling unit.

9. One embodiment of the invention of the Safe Storage Patent is shown in Fig. 5 thereof, in which a plurality of host computers are connected to two RAID controllers by using hubs or switches:

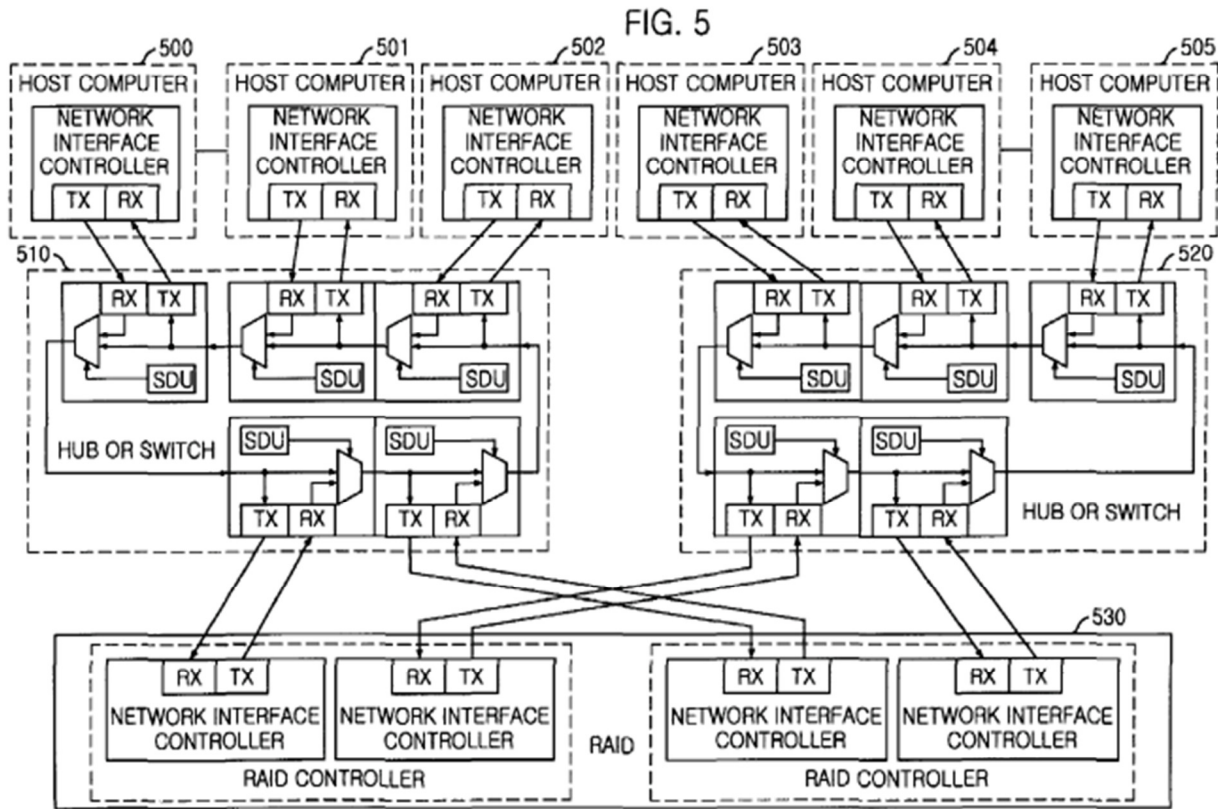

10. Defendant has been and now is directly infringing the Safe Storage Patent, in this judicial District and elsewhere in the United States, by, among other things, making, using, importing, offering for sale, and/or selling redundant RAID storage system products and services that include an apparatus for a redundant interconnection between multiple hosts and a RAID, comprising: a first RAID controlling unit and a second RAID controlling unit for processing a requirement of numerous host computers, the first RAID controlling unit including a first network controlling unit and a second network controlling unit, and the second RAID controlling unit including a third network controlling unit and a fourth network controlling unit; and a plurality of connection units for connecting the first RAID controlling units and the second RAID controlling unit to the numerous host computers, wherein the first RAID controlling unit and the second RAID controlling unit directly exchange information with the numerous host computers through the plurality of connecting units, and the first network controlling unit

exchanges information with the fourth network controlling unit, and the second network controlling unit exchanges information with the third network controlling unit. The infringing products and services include, for example, Defendant's AssuredSAN™ 8Gb Fibre Channel SAN Storage.

11. Defendant has had knowledge of the Safe Storage Patent since at least November 29, 2012, when it received a letter identifying the '346 Patent, the accused products, and exemplary evidence of infringement, and Defendant has induced its customers to assemble and use an apparatus for a redundant interconnection between multiple hosts and a RAID, comprising: a first RAID controlling unit and a second RAID controlling unit for processing a requirement of numerous host computers, the first RAID controlling unit including a first network controlling unit and a second network controlling unit, and the second RAID controlling unit including a third network controlling unit and a fourth network controlling unit; and a plurality of connection units for connecting the first RAID controlling units and the second RAID controlling unit to the numerous host computers, wherein the first RAID controlling unit and the second RAID controlling unit directly exchange information with the numerous host computers through the plurality of connecting units, and the first network controlling unit exchanges information with the fourth network controlling unit, and the second network controlling unit exchanges information with the third network controlling unit.

12. For example, Defendant has instructed users of the Dot Hill AssuredSAN™ 8Gb Fibre Channel SAN Storage that redundant components in a storage network are necessary if continuous access to storage is of paramount importance, so the Dot Hill AssuredSAN storage system typically comes pre-configured with redundant controllers and redundant power supplies. Therefore, the loss of any one of these components will not compromise access to

storage. In addition, Defendant has instructed users of the Dot Hill AssuredSAN™ 8Gb Fibre Channel SAN Storage that deploying multiple switches in the network is necessary to eliminate the switch as a single point of failure, and that, beyond the deployment of redundant components, another important aspect of redundancy in a storage network is in the cabling. Specifically, Defendant has instructed users of the Dot Hill AssuredSAN™ 8Gb Fibre Channel SAN Storage that proper cabling provides redundancy, so that the failure of any one component or path does not compromise access to any of the storage, while at the same time, this redundancy should also provide a mechanism for aggregating throughput, delivering higher performance to the host systems. Defendant has referred users of the Dot Hill AssuredSAN™ 8Gb Fibre Channel SAN Storage to use the configuration diagram in Figure 1 below as an example of proper redundant cabling, which Defendant describes as a very common SAN configuration used in most storage networks to provide optimum use of bandwidth while maintaining redundant connectivity to storage:

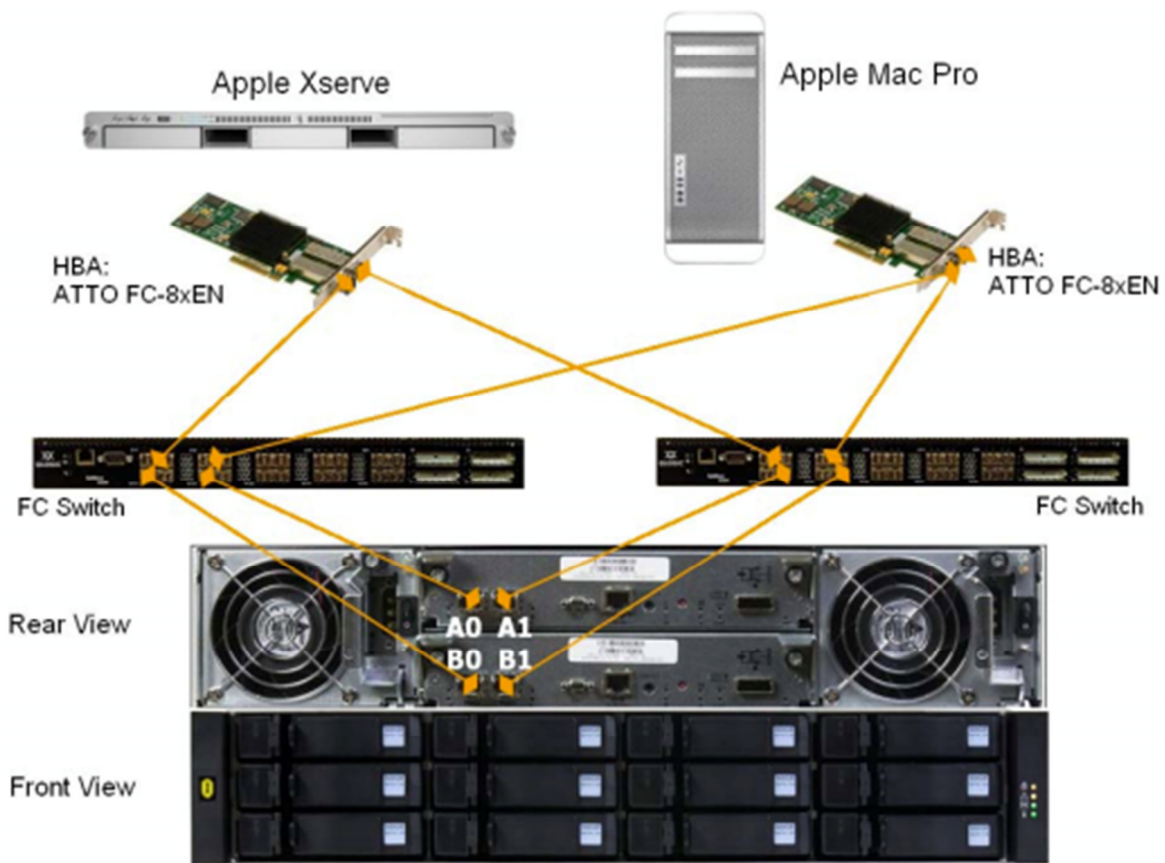

Figure 1

Apple / AssuredSAN Reference Configuration

13. Thus, Defendant has induced its customers to infringe the Safe Storage Patent. Upon information and belief, Defendant acted with the specific intent to induce its customers to make and use the apparatus claimed by the Safe Storage Patent by continuing the above-mentioned activities with knowledge of the Safe Storage Patent.

14. By engaging in the conduct described herein, Defendant has injured Safe Storage and is thus liable for infringement of the '346 Patent pursuant to 35 U.S.C. § 271.

15. Defendant has committed these acts of infringement without license or authorization.

16. As a result of Defendant's infringement of the '346 Patent, Safe Storage has suffered monetary damages and is entitled to a money judgment in an amount adequate to

compensate for Defendant's infringement, but in no event less than a reasonable royalty for the use made of the invention by Defendant, together with interest and costs as fixed by the Court, and Safe Storage will continue to suffer damages in the future unless Defendant's infringing activities are enjoined by this Court.

17. Safe Storage has also suffered and will continue to suffer severe and irreparable harm unless this Court issues a permanent injunction prohibiting Defendant, its agents, servants, employees, representatives, and all others acting in active concert therewith from infringing the '346 Patent.

PRAYER FOR RELIEF

Safe Storage respectfully requests that this Court enter:

- A. A judgment in favor of Safe Storage that Defendant has infringed, directly and/or indirectly, the '346 Patent;
- B. A permanent injunction enjoining Defendant and its officers, directors, agents, servants, affiliates, employees, divisions, branches, subsidiaries, parents, and all others acting in active concert therewith from infringement of the Safe Storage Patent, or such other equitable relief the Court determines is warranted;
- C. A judgment and order requiring Defendant to pay Safe Storage its damages, costs, expenses, and prejudgment and post-judgment interest for Defendant's infringement of the '346 Patent as provided under 35 U.S.C. § 284;
- D. A judgment and order finding that this is an exceptional case within the meaning of 35 U.S.C. § 285 and awarding to Safe Storage its reasonable attorneys' fees against Defendant;

- E. A judgment and order requiring Defendant to provide an accounting and to pay supplemental damages to Safe Storage, including without limitation, pre-judgment and post-judgment interest; and
- F. Any and all other relief to which Safe Storage may be entitled.

DEMAND FOR JURY TRIAL

Safe Storage, under Rule 38 of the Federal Rules of Civil Procedure, requests a trial by jury of any issues so triable by right.

Dated: November 30, 2012

BAYARD, P.A.

OF COUNSEL:

Alexander C.D. Giza
Marc A. Fenster
RUSS, AUGUST & KABAT
12424 Wilshire Boulevard 12th Floor
Los Angeles, California 90025
(310) 826-7474
agiza@raklaw.com
mfenster@raklaw.com

/s/ Richard D. Kirk
Richard D. Kirk (rk0922)
Stephen B. Brauerman (sb4952)
Vanessa R. Tiradentes (vt5398)
222 Delaware Avenue, Suite 900
Wilmington, DE 19801
(302) 655-5000
rkirk@bayardlaw.com
sbrauerman@bayardlaw.com
vtiradentes@bayardlaw.com

Attorneys for Plaintiff Safe Storage LLC